

Assembly and operating instructions

Linear Module LM 32

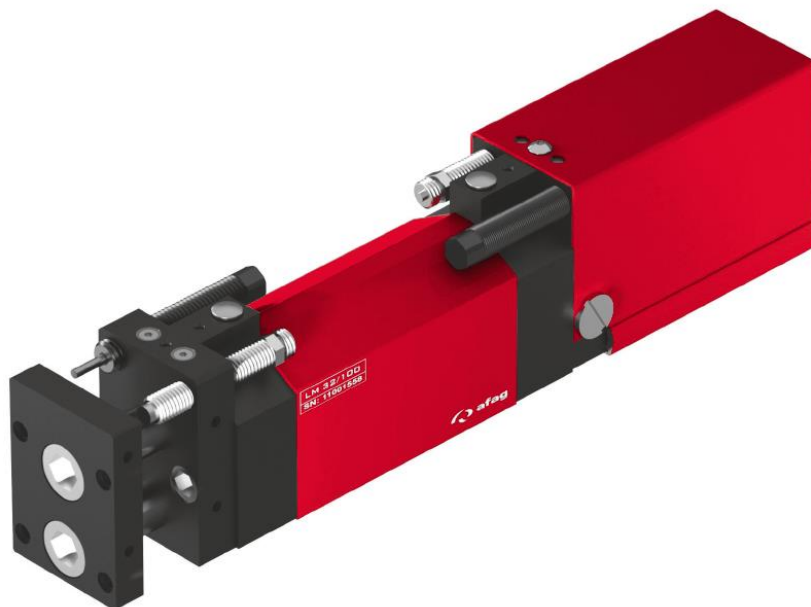

Translation of the Original Assembly Instructions EN

- LM 32/100 ⇨ Order no.: 11001558
- LM 32/200 ⇨ Order no.: 11001559
- LM 32/300 ⇨ Order no.: 11001561
- LM 32/400 ⇨ Order no.: 11001562

Dear Customer

Thank you for choosing our products and placing your trust and confidence in our company!

These assembly and operating instructions contain all essential information you need about your product. Our aim is to provide the required information as concisely and clearly as possible. If, however, you still have any questions on the contents or suggestions, please do not hesitate to contact us. We are always grateful for any feedback.

Our team will also be glad to answer any further question you may have regarding the linear module or other options.

We wish you every success with our products!

With kind regards

Your Afag team

© Subject to modifications

The linear modules have been designed by Afag Automation AG according to the state of the art. Due to the constant technical development and improvement of our products, we reserve the right to make technical changes at any time.

Updates of our documentations



Unlike the printed documents, our digital instructions manuals, product data sheets and catalogues are being continuously updated on our website.

Please keep in mind that the digital documents on our website are always the latest versions.

© Copyright 2023 Afag Automation AG

All contents of the present assembly and operating instructions, in particular the texts, photographs and graphics, are protected by copyright. All rights reserved. No part of these assembly and operating instructions may be reproduced, distributed (made available to third parties), or transmitted in any form or by any means, including photocopying, recording, or other electronic or mechanical methods, without the prior written permission of Afag Automation AG.

Afag Automation AG
Luzernstrasse 32
CH-6144 Zell (Switzerland)
Tel.: +41 62 959 86 86
e-mail: sales@afag.com
Internet: www.afag.com

Table of contents

1	General	5
1.1	Contents and purpose of these assembly instructions.....	5
1.2	Explanation of symbols.....	5
1.3	Additional symbols.....	6
1.4	Applicable documents	7
1.5	Warranty	7
1.6	Liability.....	7
2	Safety instructions	8
2.1	General.....	8
2.2	Intended use.....	8
2.3	Foreseeable misuse	8
2.4	Obligations of the operator and the personnel	9
2.4.1	Observe the assembly instructions	9
2.4.2	Obligations of the operating company.....	9
2.4.3	Obligations of the personnel	10
2.5	Personnel requirements	10
2.5.1	Personnel qualification	10
2.6	Personal protective equipment (PPE)	11
2.7	Changes & Modifications.....	11
2.8	General hazards / residual risks.....	12
2.8.1	General hazards at the workplace	12
2.8.2	Mechanical hazards	12
2.8.3	Danger due to electricity	13
2.8.4	Danger due to pneumatics	13
2.8.5	Noise hazards	13
3	Technical data	14
3.1	Dimensional drawing LM 32	14
3.1.1	Technical data LM 32	15
3.1.2	Preferred combinations LM 32	16
3.1.3	Slide loads LM 32.....	17
4	Transport, packaging and storage	18
4.1	Safety instructions for transport.....	18
4.2	Scope of supply	19
4.3	Transport	19
4.4	Packaging.....	19
4.5	Storage	20
5	Design and description	21
5.1	Design of linear module LM 32.....	21
5.2	Product description.....	21
5.3	Accessories	22

6	Installation, assembly and setting	23
6.1	Safety Instructions for Installation and assembly	23
6.2	Assembly and attachment	24
6.2.1	Attachment options.....	24
6.2.2	Tightening torques.....	26
6.3	Intermediate stop ZA 32	27
6.3.1	Design and functioning of the ZA 32.....	27
6.3.2	Mounting options of the ZA 32	28
6.3.3	Adjustment of the ZA 32 (example rear mounting)	30
6.4	Mounting the initiators	31
6.4.1	Mounting the initiator 6.5 mm.....	33
6.4.2	Mounting initiator 8x8 mm	34
6.5	Pneumatic connections	35
7	Commissioning	37
7.1	Safety instructions for commissioning	37
7.2	Preparatory activities for commissioning.....	37
7.2.1	Adjustment of stop screws AS 12/60	37
7.2.2	Stroke adjustment	38
7.2.3	Adjustment of the shock absorber.....	39
7.3	First commissioning.....	40
8	Fault elimination	41
8.1	Safety instructions for troubleshooting	41
8.2	Fault causes and remedy	41
9	Maintenance and repair	42
9.1	General notes	42
9.2	Safety instructions for Maintenance and Repair	42
9.3	Maintenance activities and maintenance intervals.....	43
9.3.1	Overview of the maintenance points.....	43
9.3.2	Compressed air specifications	44
9.3.3	Further maintenance	45
9.4	Spare and wear parts lists, repairs.....	45
9.4.1	Wear parts.....	46
9.4.2	Wear parts set for LM 32-100, -200, -300, -400.....	46
9.4.3	Replacing wear parts (LM 32).....	47
9.4.4	Wear parts intermediate stop ZA	48
9.4.1	Spare parts for ZA 32.....	49
10	Decommissioning, disassembly, disposal	50
10.1	Safety instructions	50
10.2	Decommissioning	50
10.3	Disposal.....	50
11	Declaration of incorporation	51

1 General

1.1 Contents and purpose of these assembly instructions

These assembly instructions contain important information on assembly, commissioning, functioning and maintenance of the module LM 32 to ensure safe and efficient handling and operation.

Consistent compliance with these assembly instructions will ensure:

- permanent operational reliability of the module,
- optimal functioning of the module,
- timely detection and elimination of defects (thereby reducing maintenance and repair costs),
- prolongation of the module service life.

The illustrations in this manual shall provide you with a basic understanding of the module and may vary from the actual design of your module.

1.2 Explanation of symbols

The safety notes are marked by a pictogram and a signal word. The safety notes describe the extent of the hazard.

DANGER



Danger!

This safety note indicates an imminently hazardous situation which, if not avoided, will result in death or serious injury.

WARNING



Warning!

This safety note points out a potentially hazardous situation which, if not avoided, could result in death or serious injury.

CAUTION



Caution!

This safety note points out a potentially dangerous situation which, if not avoided, can result in minor or slight injuries.

NOTICE

This safety note points out a potentially dangerous situation which, if not avoided, can cause substantial damage to property and the environment.



This note contains important additional information as well as useful tips for safe, efficient and trouble-free operation of the module.

Further warning signs:

Where applicable, the following standardised symbols are used in this manual to point out the various potential health risks.

	Warning - Dangerous electrical voltage.
	Warning - Risk of injury from contact with hot surfaces.
	Warning - Risk of hand and finger injury due to uncontrolled movements of components.
	Warning - Risk of injury because of parts being flung out!
	Warning -high noise levels

1.3 Additional symbols

In these assembly instructions the following symbols are used to highlight instructions, results, references, etc..

Symbol	Description
1.	Instructions (steps ...)
⇒	Results of actions
↻	References to sections
■	Enumerations not ordered

1.4 Applicable documents



Each linear module is accompanied by a safety information sheet. This information sheet must be read carefully by every person who carries out work on and with the module.

1.5 Warranty

The warranty terms for Afag handling components and handling systems are the following:

- 24 months from initial operation and up to a maximum of 27 months from delivery.
- Wear parts are excluded from the warranty (The customer is entitled to a product free of defects. *This does also apply to defective accessories and wear parts. Normal wear and tear are excluded from the warranty.*)

The warranty covers the replacement or repair of defective Afag parts. Further claims are excluded.

The warranty shall expire in the following cases:

- Improper use of the module.
- Non-observance of the instructions regarding assembly, commissioning, operation and maintenance of the module.
- Improper assembly, commissioning, operation and maintenance.
- Repairs and design changes carried out without prior technical instructions of Afag Automation AG.
- Removing the serial number from the product.
- Inadequate checking of wear parts.
- Non-observance of the EC Machinery Directive, the Accident Prevention Regulations, the Standards of the German Electrotechnology Association (VDE) and these safety and assembly instructions.

1.6 Liability

No changes shall be made to the linear module unless described in this instructions manual or approved in writing by Afag Automation AG.

Afag Automation AG accepts no liability for unauthorized changes or improper assembly, installation, commissioning, operation, maintenance or repair work.

2 Safety instructions

2.1 General

This chapter provides an overview of all important safety aspects to ensure safe and proper use of the linear module and optimal protection of personnel. Safe handling and trouble-free operation of the linear module requires knowledge of the basic safety regulations.

Every person carrying out installation, commissioning, maintenance work or operating the module must have read and understood the complete user manual, especially the chapter on safety instructions.

Beyond this, there are rules and regulations regarding accident prevention that are applicable to the place of installation which must be observed.

Improper use may result in danger to life and limb of the user or third parties or in damage to the automation system or other material assets.



Failure to follow the directions and safety instructions given in this instructions manual may result in serious hazards.

2.2 Intended use

The LM 32 linear module is used for ambient of fixed mounted loads in **non-hazardous** environments in the ambient/application conditions for these modules defined (➔ chap. 3 "Technical data").

The LM 32 linear modules are designed exclusively for the linear movement of payloads of 5-10 kg (➔ chap. 3 "Technical data").

The modules LM 32 can be used in combination with other modules as a pick converted place station, whereby the permissible load capacity must not be exceeded.

Any use beyond the described purpose is not in accordance with the intended use.

The intended use of the module also includes:



- observance of all instructions given in this instructions manual.
 - compliance with the inspection and maintenance work and the specifications in the data sheets,
 - using only original spare parts.
-

2.3 Foreseeable misuse

Any use other than or beyond the intended use described above is considered a misuse of the linear compensation.

Especially the following use is considered a misuse:

- Use in potentially explosive atmospheres

WARNING



Risk of injury if the module is not used as intended!

The improper use of the linear modules poses a potential hazard to the personnel.

- The linear modules may only be used in a technically perfect condition in accordance with its intended use and the instructions in this manual as well as in compliance with the safety requirements!
- Any malfunctions, particularly those that could impair safety, must be eliminated immediately!



Risks can occur if the module is not used as intended. In the event of damages caused by improper use the following shall apply:

- the operating company shall be solely responsible for such damage, and
- Afag does not accept any liability for damage caused by improper use.

2.4 Obligations of the operator and the personnel

2.4.1 Observe the assembly instructions

A basic prerequisite for safe and proper handling of the linear module is a good knowledge of the basic safety instructions.



These assembly instructions, in particular the safety instructions contained therein, must be observed by all persons working with the linear module.

2.4.2 Obligations of the operating company

In addition to the safety instructions given in this manual, the operating company must comply with the safety, accident prevention and environmental protection regulations valid for the field of application of the linear module.

The operating company is required to use only personnel who :

- have the necessary professional qualifications and experience,
- are familiar with the basic rules regarding occupational safety and accident prevention,
- have been instructed in the correct handling of the stroke linear module,
- have read and understood these assembly instructions.

The operating company is also required to:

- monitor on an ongoing basis that the personnel work safely considering any potential hazard involved and the assembly instructions are observed,
- ensure that the assembly instructions are always kept at hand at the installation in which the modules are mounted,
- observe and communicate universally applicable laws and regulations regarding accident prevention and environmental protection,
- provide the necessary personal protective equipment (e.g., protective gloves) and instruct the personnel to wear it.

2.4.3 Obligations of the personnel

All personnel working with the are required to:

- read and observe these assembly instructions, especially the chapter on safety,
- observe the occupational safety and accident prevention regulations,
- observe all safety and warning signs on the module,
- refrain from any activity that might compromise safety and health.



In addition, the personnel must wear the personal protective equipment required for carrying out their work (→ chap. 2.6).

2.5 Personnel requirements

2.5.1 Personnel qualification

The activities described in the assembly instructions require specific requisites at the level of professional qualifications of the personnel.

Personnel not having the required qualification will not be able to assess the risks that may arise from the use of the module thus exposing himself and others to the risk of serious injury. Therefore, only qualified personnel may be permitted to carry out the described activities on the linear module. Persons whose ability to react is restricted due to the intake of medication or the like must not interact with the linear module.

These installation instructions are intended for skilled personnel (installers, system integrators, maintenance personnel, technicians), electricians and operating personnel.

The following is a description of the professional skills (qualifications) required for carrying out the different activities:

Qualified personnel:

Qualified personnel with appropriate training who are qualified due to their special know-how and fully familiar with the machine and who have been given instructions on how to carry out the task entrusted to them safely.

Operator (trained personnel):

Authorized persons who due to their specialized professional training, expertise and experience can identify risks and preventing possible hazards arising from the use of the machine.





2.6 Personal protective equipment (PPE)

The personal protective equipment serves to protect the personnel from hazards affecting their safety and health at work.

When working on/with the linear, the personnel must wear the personal protective equipment assigned by the safety officer of the operating company or as required by safety regulations. In addition, the personnel is required to:

- wear the personal protective equipment provided by the operating company (employer),
- check the personal protective equipment for proper condition, and
- immediately notify the person responsible on site of any defects found on the personal protective equipment.

Personal protective equipment and the respective mandatory signs:

	<p><i>Protective clothing</i> is a close-fitting clothing specifically designed to protect personnel from hazards during work.</p>
	<p><i>Protective gloves</i> are specifically designed to protect the personnel against hand injuries (such as cuts, abrasion, burns).</p>
	<p><i>Safety shoes</i> are specifically designed to protect the personnel against foot injuries from crushing, falling objects or slipping on slippery surfaces.</p>
	<p>Hearing protectors are required to protect the personnel against excessive noise levels to prevent noise-induced hearing loss.</p>

2.7 Changes & Modifications

No changes may be made to the linear module which have not been described in these assembly instructions or approved in writing by Afag Automation AG.

Afag Automation AG accepts no liability for unauthorised changes or improper assembly, installation, commissioning, maintenance or repair work.



The linear module may not be changed or modified in any way, except with the prior written consent of Afag Automation AG.

2.8 General hazards / residual risks

Despite the safe design of the linear module and the technical protective measures taken, there still remain residual risks that cannot be avoided, and which present a non-obvious residual risk when operating the module.

Observe the safety instructions in this chapter and in the other sections of this manual to avoid damage to property and dangerous situations for the personnel.

2.8.1 General hazards at the workplace

The modules have been built according to the state-of-the-art and the applicable health and safety requirements. However, improper use of the linear module may cause the following hazards to the personnel:

- danger to life and limb of the operator or third parties,
- on the linear modules themselves,
- property damage.



Always keep the assembly instructions ready at hand at the workplace! Please, also observe:

- the general and local regulations on accident prevention and environmental protection,
- the safety information sheet for the linear module.

WARNING



Danger - Do not use in unsuitable environment !

The linear modules are designed for the application and environmental conditions defined in chapter 3 "Technical data".

- **Only** use the linear module under the defined operating and ambient conditions!

2.8.2 Mechanical hazards

CAUTION



Risk of injuries by moving parts and unexpected movements!

When operating the linear module uncontrolled movements may occur which can cause personal injury or property damage. There is always a risk of injury by moving parts during normal operation.

- Only qualified personnel may work with or on the linear modules.
- Never reach into the system during normal operation!

2.8.3 Danger due to electricity

DANGER



Danger! Risk of electric shock!

If work on electrical components is required, ensure that the work is carried out properly, failure to do so will cause serious or fatal injuries.

- Work on the machine's electrical equipment may only be performed by skilled electrician or trained personnel under the supervision of a skilled electrician in accordance with all relevant electrical regulations.
-

2.8.4 Danger due to pneumatics

WARNING



Risks by the pneumatic system!

If work on electrical components is required, ensure that the work is carried out properly, failure to do so will cause serious or fatal injuries.

- Work on the machine's electrical equipment may only be performed by skilled electrician or trained personnel under the supervision of a skilled electrician in accordance with all relevant electrical regulations.
-

2.8.5 Noise hazards

CAUTION



Noise hazards!

The linear module generates 68 dB(A) during full-load operation. Depending on the add-ons, the environment and the resonance of the protective device these values may be exceeded and expose the operator to a higher noise level.

- It is the responsibility of the operating company to ensure that the permitted noise limit values are not exceeded.
 - If the permitted noise levels cannot be met it must be ensured that the operating personnel wears the required hearing protection.
-

3 Technical data

3.1 Dimensional drawing LM 32

Typ	LM 32/100	LM 32/200	LM 32/300	LM 32/400
A	360 mm	560 mm	760 mm	960 mm
B	226 mm	326 mm	426 mm	526 mm
D	140 mm	240 mm	340 mm	440 mm
E	2	4	6	8
F	365 mm	565 mm	765 mm	965 mm
H	100 mm	200 mm	300 mm	400 mm
P	G 1/8 "	G 1/8 "	G 1/8 "	G 1/8 "

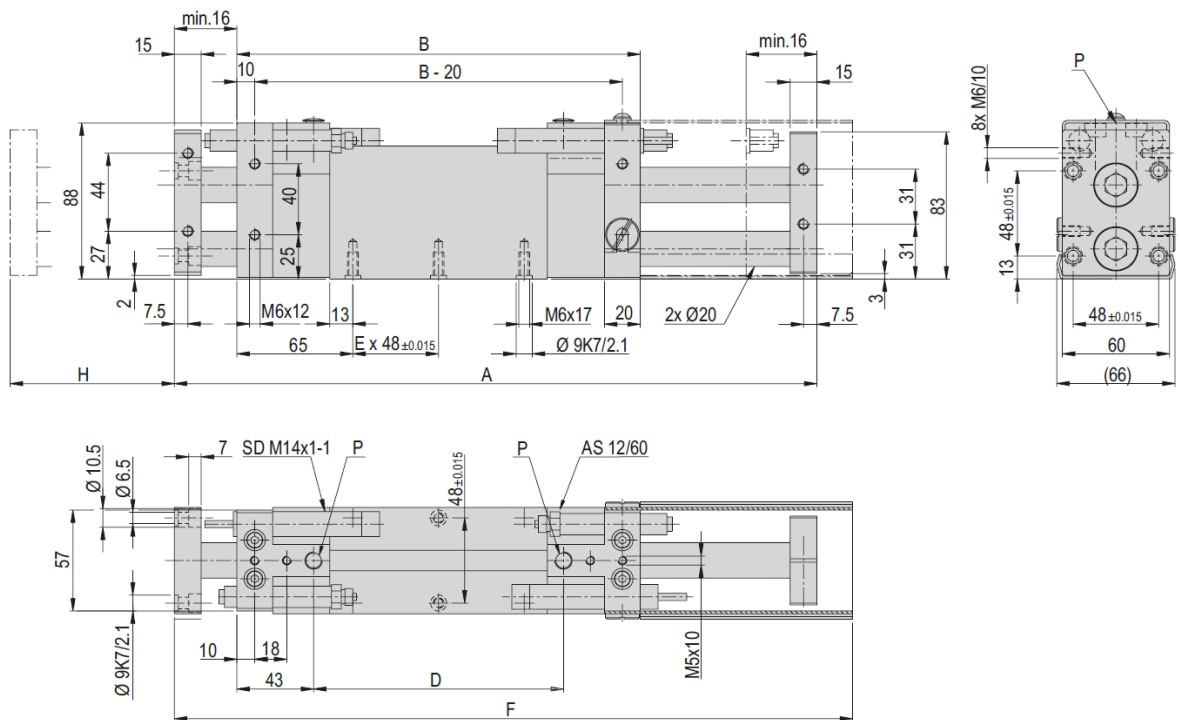

Fig. 1 Dimensional drawing LM 32

Technical data

3.1.1 Technical data LM 32

LM 32	
Befestigungs raster	48 x 48 mm
Befestigungsgewinde	M6
Betriebsdruck	6 +/- 2 bar
Luftanschluss P	G1/8 "
Zylinder Ø	32 mm
Kolbenkraft einfahren	295 N
Kolbenkraft ausfahren	295 N
Betriebstemperatur	0 - 50 °C
Lagerungstemperatur	0 - 50 °C
Luftfeuchtigkeit	< 90 %
Medium gefilterte Druckluft	10 - 40 µm

Typ	LM 32/100	LM 32/200	LM 32/300	LM 32/400
Bestellnummer	11001558	11001559	11001561	11001562
Hub H	100 mm	200 mm	300 mm	400 mm
Hubbegrenzung	2 x 40 mm	2 x 40 mm	2 x 40 mm	2 x 40 mm
Nettogewicht	4 kg	5.4 kg	6.6 kg	7.9 kg
Gewicht bewegt	1.81 kg	2.29 kg	2.79 kg	3.28 kg
Luftverbrauch/Zyklus	0.4 NL	0.8 NL	1.2 NL	1.6 NL
Lärmpegel	65 dB (A)	65 dB (A)	65 dB (A)	65 dB (A)
Wiederholgenauigkeit	+/- 0.01 mm	+/- 0.01 mm	+/- 0.02 mm	+/- 0.02 mm
Einbaulage	✦	✦	✦	✦

Die technischen Daten beziehen sich auf einen Nenndruck von 6 bar und Afag Standard-Testbedingungen.
Das Modul kann mit geölter oder ölfreier Luft betrieben werden
Reinraumklasse ISO 14644-1, Klasse ISO 7

Im Lieferumfang inbegriffen

- (Katalog HT Zubehör)
- 2x Zentrierhülse Ø9x4
 - 2x Anschlagsschraube AS 12/60
 - 2x Stoßdämpfer SD M14x1 -1

Zubehör

- (Katalog HT Zubehör)
- INI d6.5x44-Sn1.5-PNP-NO-M8x1

Alternatives Zubehör

- (Katalog HT Zubehör)
- INI d6.5x35-Sn1.5-PNP-NO-M8x1

3.1.2 Preferred combinations LM 32

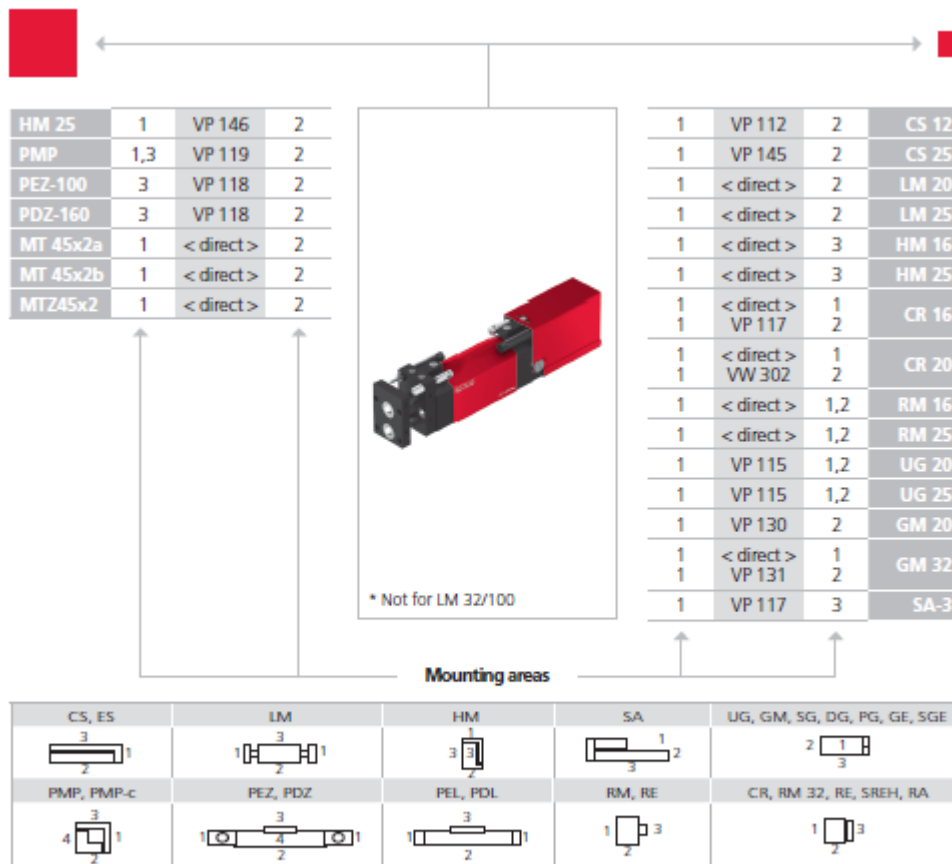

Note that there might be different mounting positions from one module to another one.
The required connection elements and the range of support columns are depicted in the catalogue HT accessories.

Technical data

3.1.3 Slide loads LM 32

Typ	LM 32/100	LM 32/200	LM 32/300	LM 32/400
Max statisches Moment Mx	12 Nm	12 Nm	12 Nm	12 Nm
Max statisches Moment My	95 Nm	127 Nm	158 Nm	190 Nm
Max statisches Moment Mz	95 Nm	127 Nm	158 Nm	190 Nm
Max dynamisches Moment Mx	5 Nm	5 Nm	5 Nm	5 Nm
Max dynamisches Moment My	43 Nm	57 Nm	71 Nm	85 Nm
Max dynamisches Moment Mz	43 Nm	57 Nm	71 Nm	85 Nm
Wirkabstand Wx	311 mm	411 mm	511 mm	611 mm

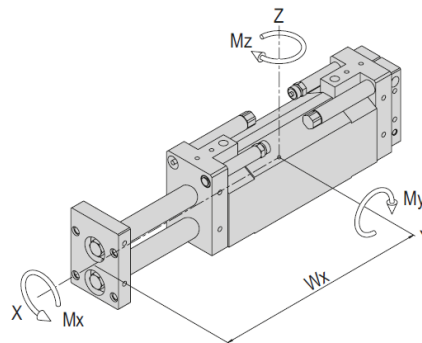

Maximale Nutzlast/Typ	LM 32/100	LM 32/200	LM 32/300	LM 32/400
Einbaulage horizontal bei Anbauseite 1	10 kg	9 kg	7 kg	5 kg
Einbaulage horizontal bei Anbauseite 3	10 kg	9 kg	7 kg	5 kg
Einbaulage vertikal bei Anbauseite 1	10 kg	9 kg	7 kg	5 kg
Einbaulage vertikal bei Anbauseite 3	10 kg	9 kg	7 kg	5 kg

Anbauseiten Moduleinbau horizontal:

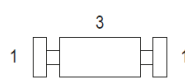

vertikal:

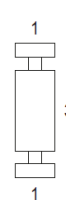

Verfahrzeit-Diagramme

Hubzeit LM 32 mit Stoßdämpfer

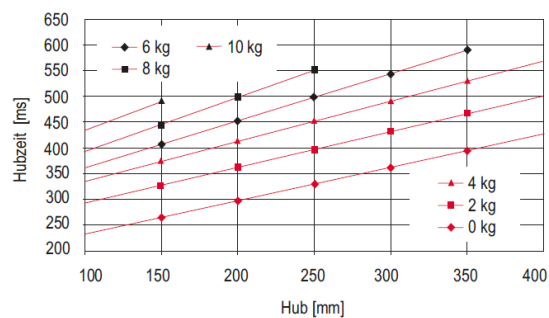

4 Transport, packaging and storage

4.1 Safety instructions for transport



The linear module LM 32 are fine mechanical unit and must be handled with the necessary care and cleanliness during transport and storage as well as when handling, setting up and assembling!



CAUTION

Risk of injury when unpacking the module!

The linear modules are packed in the original packaging (cardboard box). If handled incorrectly, the module may fall box when unpacked and cause limb injuries.

- Carefully unpack the linear modules.

Danger of crushing!

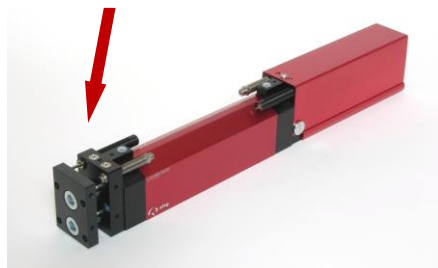

Fig. 2 LM 32 unpacked in the original packaging



Also observe the safety instructions in ➔ chap. 2 „Safety instructions“ in this manual.

4.2 Scope of supply



The scope of delivery of the modules includes assembly and operating instructions as well as a safety information sheet.

The assembly and safety information sheet must be read by every person who carries out work with and on modules!

[Unt]	LM 32
1 x	Piston
1 x	Guide shaft
1 x	Housing
1 x	Front plate
1 x	Rear plate
2 x	Stop screws AS 12/60
2 x	Shock absorber SD M14x1-1
1 x	Piston rod

4.3 Transport



No liability can be assumed for damages caused by improper installation on the part of the operating company.



The following conditions must be complied with for transport and storage:

- Storage temperature: 0-50 °C
- Relative air humidity: < 90%, non condensing

4.4 Packaging

The linear module is transported in the Afag Automation original packaging. If no Afag packaging is used, the linear module must be packed in such a way that it is protected against shocks and dust.

NOTICE

Risk to the environment due to incorrect disposal of the packaging material!

Environmental damage can be caused by incorrect disposal of the packaging material.

- Dispose of the packaging material in an environmentally sensitive way in accordance with the local environmental regulations.

4.5 Storage

If the linear module is stored for an extended period, observe the following:

- Store the module in the transport packaging.
- Do not store the telescope spindle axes outdoors or expose them to weather conditions.
- The storage space must be dry and dust free.
- Room temperature of the storage space: 0-50 °C.
- Relative air humidity: < 90% non condensing.
- Clean the module and protect the blank metal parts against corrosion using the appropriate means.
- Protect the linear module module from dirt and dust.

5 Design and description

5.1 Design of linear module LM 32

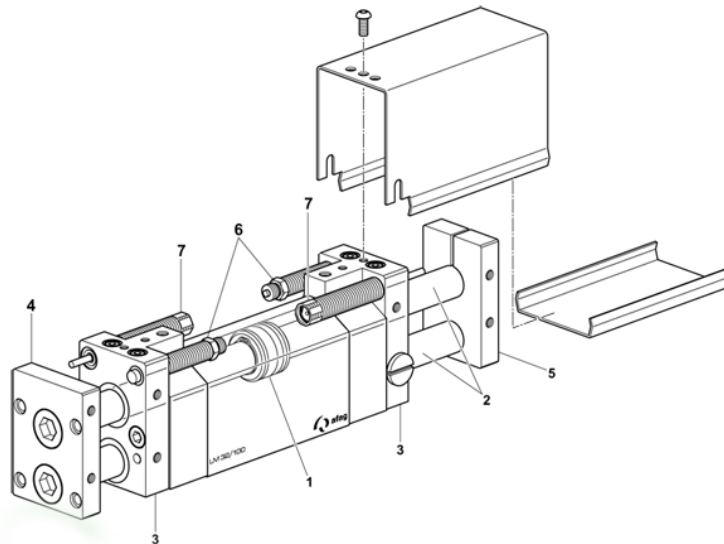

Fig. 3 Structure of the linear module LM 32

- | | |
|----------------|------------------------------|
| 1. Piston | 5. Rear plate |
| 2. Guide shaft | 6. Stop screws AS 12/60 |
| 3. Housing | 7. Shock absorber SD M14x1-1 |
| 4. Front plate | 8. Piston rod |

5.2 Product description

The LM 32 is a pneumatically operated device for longitudinal movements with a stroke of 0 mm to 400 mm.

A pneumatic, double-acting piston (1) generates the longitudinal movement. The guide shaft (2) and the piston rod (8), guided by bearing bushes lubricated for life in the housing (3), connect the front (4) and rear (5) plates. The infinitely adjustable stop screws (6) limit the stroke. The stroke end position is damped with Afag shock absorbers (7).

5.3 Accessories

Cr.	Designation	Order Number
1	Intermediate position module ZA 32 (intermediate stop)	11009325
2	Front stop bar	➔ Technical catalogue
3	Rear stop bar	➔ Technical catalogue
4	Hand guard narrow	➔ Technical catalogue
5	Hand guard wide	➔ Technical catalogue
6	Initiator INI d6.5x44-Sn1.5-PNP-NO-M8x1	11005439
7	Initiator holder 6.5 mm	11004995
8	Initiator INI 8x8x38.5-Sn2.0-PNP-NO-M8x1	50338170
9	Initiator holder 8x8 mm	11004997

6 Installation, assembly and setting



The system operator is responsible for the installation of the linear module in a system!

When integrating a linear module into an assembly system, the customer must provide an appropriate enclosure or safety barrier.

6.1 Safety Instructions for Installation and assembly

The linear module is an incomplete machine.

For safe operation, the linear module must be integrated into the safety concept of the system in which they are installed.

During normal operation, it must be ensured that the user cannot interfere with the working area of the linear module.

CAUTION



Risk of injury when installing the linear module in a system!

Improperly performed work can lead to injuries and damage to property.

- The installation may only be carried out by a qualified specialist!

CAUTION



Risk of injuries due to uncontrolled parts movements!

When operating the linear module uncontrolled movements may occur which cause personal injury or property damage.

- When connecting the compressed air supply for the first time, make sure that all compressed air throttles are closed.
- Vent the system slowly!



No liability for damages can be assumed for damages caused by improper installation/assembling work on the part of the operator.



Also observe the safety instructions in ↻ chap. 2 „Safety instructions“ in this manual.

6.2 Assembly and attachment



The assembly position of the the the linear module LM 32 can be horizontal or vertical.

The module base body is screwed on from below.

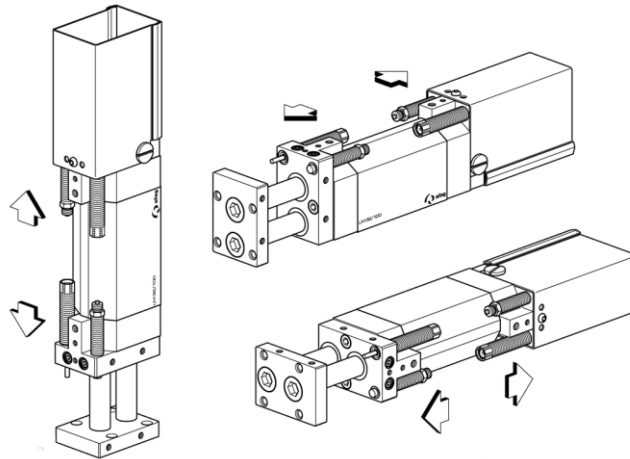

Fig. 4 Mounting position of the LM 32 is freely selectable

CAUTION



Risk of injury due to sudden movements when installed in vertical position!

When installed in a vertical position, unexpected movements may occur if the slide is not in its lowest position.

- Always move the slide to the lowest position before mounting.

6.2.1 Attachment options

Mounting the module on the base body.

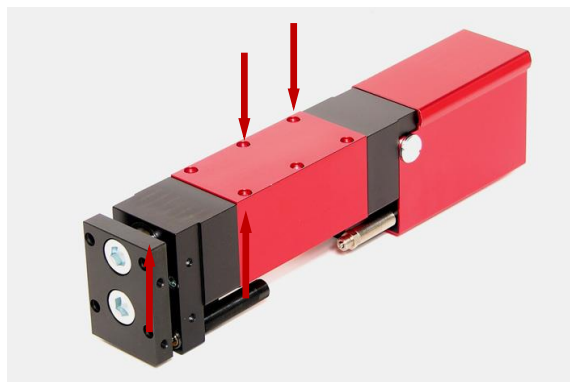

Fig. 5 Fastening the linear module to the base body

Mounting the module on the face plate:

Grid 48 x 48 mm for M6 cap screws (see dimensional drawing → chap. 3 Technical data).

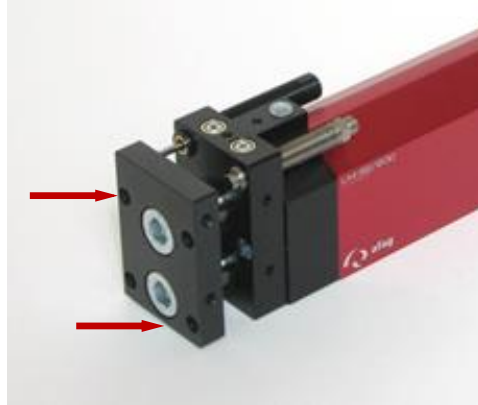

Fig. 6 Fastening the linear module to the face plate



Use the centring bushings included in the scope of delivery for positioning.

Insert the centering sleeves into two diagonally opposite holes of the attachment grid.

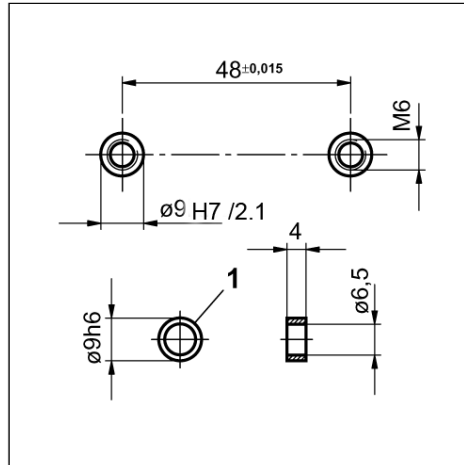

Fig. 7 Fastening with centring sleeve

6.2.2 Tightening torques

Use screws with the following minimum specifications for mounting:

Standard	VDI 2230
Strength:	Category 8.8
Surface:	Galvanized blue, oiled or greased

Thread	Tightening torque
M3	1.1 ... 1.3 Nm
M4	2.5 ... 2.9 Nm
M5	4.9 ... 5.8 Nm
M6	8.5 ... 9.9 Nm

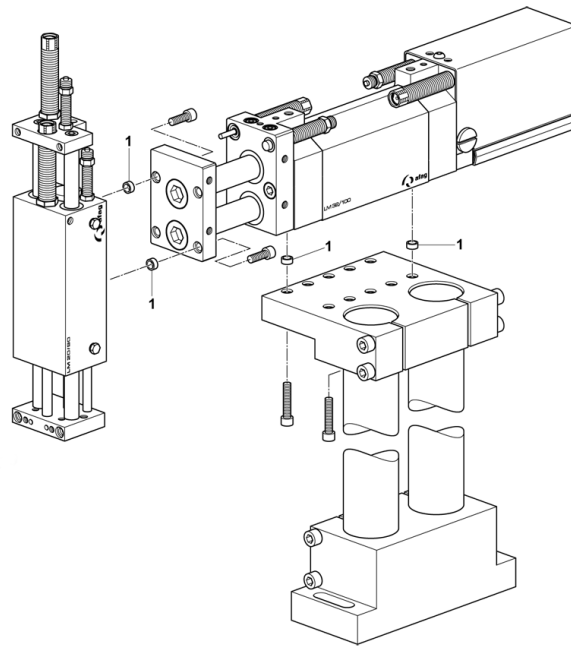

Fig. 8 Tightening torques for fastening screws

6.3 Intermediate stop ZA 32

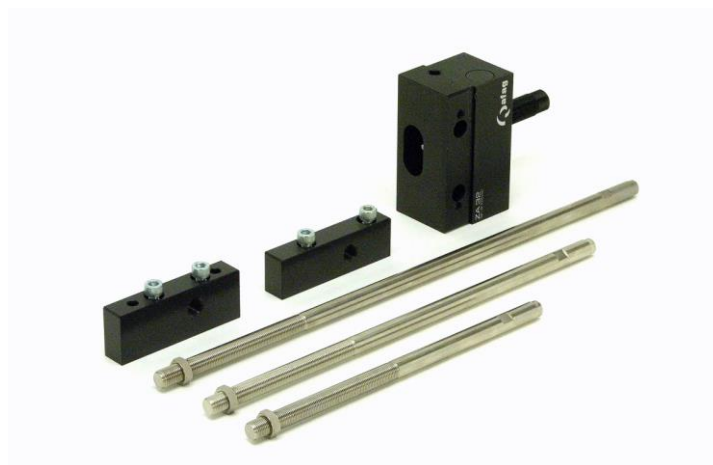

Fig. 9 Intermediate stop ZA 32

The intermediate stop ZA 32 is an additional module for the linear module LM 32. The intermediate stop is used when an intermediate position is required within the stroke range of the LM 32.

6.3.1 Design and functioning of the ZA 32

The pneumatic, double-acting piston (Fig. F0, 8) is connected to a shock absorber (Fig. 10, 9) and generate a vertical stroke.

When the piston (Fig. 10, 8) is at the top of the stroke, the threaded rod (Fig. 10, 10) moves onto the shock absorber (Fig. 10, 9) and initiates the intermediate position. If the piston is at the lower apex, the threaded rod slides over the shock absorber without further consequences.

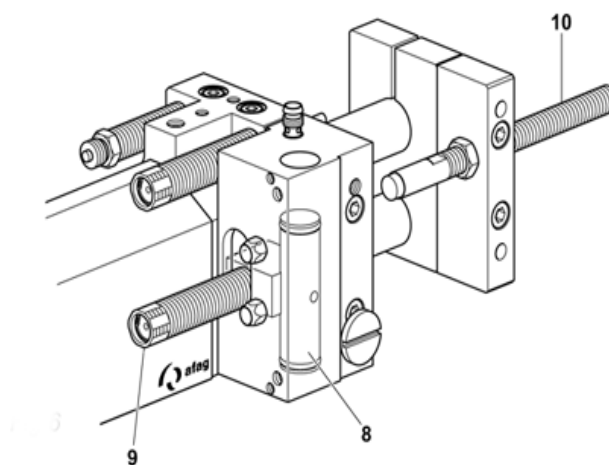

Fig. 10 Intermediate stop ZA 32

6.3.2 Mounting options of the ZA 32

Due to the symmetrical design of the ZA 32 intermediate stop, up to four units can be attached and consequently four intermediate positions can be precisely approached. Each intermediate position is damped and acknowledged with initiators.

The intermediate stop can be fitted to the front or rear (right or left) of the LM 32.

CAUTION

Risk of injury if hand protection is missing!

If the ZA is mounted on the front of the LM 32, no additional hand guard (Fig. 11, 1) can be mounted.

If the ZA 32 is mounted at the rear left and/or rear right, the use of a hand guard (Fig. 11, 1) "narrow" or "wide" is mandatory to prevent hand injuries.

- Use the hand guard provided when mounting the ZA 32 on the rear of the LM 32!
- The hand guard must be ordered separately (➔ chap. 5.3.1 Accessories).

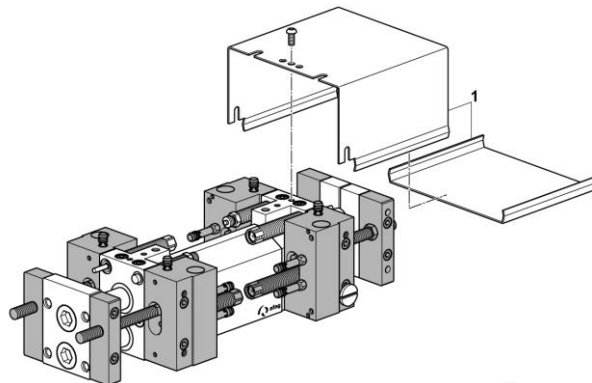

Fig. 11 Hand guard (1) for rear left/right installation

Hand guard "narrow" or "wide"

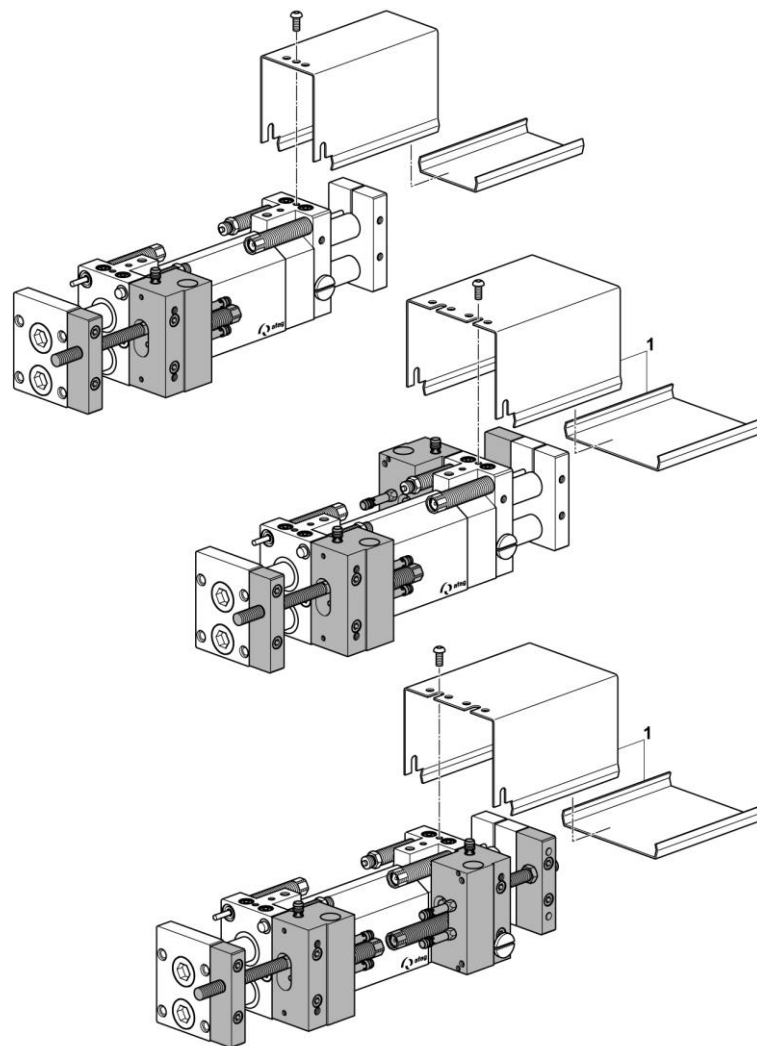

Fig. 12 Mounting variants with "narrow" or "wide" hand guard

6.3.3 Adjustment of the ZA 32 (example rear mounting)

Proceed as follows to adjust the ZA 32:

1. Fit the intermediate stop module ZA 32 (Fig. 13, 1) and the stop rod module at the rear (Fig. 13, 2) to the LM 32.
 - It is recommended to use the shortest possible stop bar!
2. Move initiators (Fig. 13, 3) to adjust their position.
 - The LED must light up on contact.
3. Then secure initiators with initiator holder (Fig. 13, 4) or stud bolts (Fig. 13, 5).
4. Apply compressed air at (P1).
 - The shock absorber (Fig. 13, 6) moves to the upper position.
5. Apply compressed air at (P2).
 - The stop bar (Fig. 13, 7) moves to the left until it is limited by the shock absorber (Fig. 13, 6).
6. Loosen the lock nut (Fig. 13, 8) and adjust the intermediate position by screwing the stop rod (Fig. 13, 7) in or out.
7. Secure the stop bar with lock nut (Fig. 13, 8).
8. Mount the hand guard (Fig. 13, 9).
9. Carry out function check.
 - ⇒ The setting of the ZA 32 is completed.

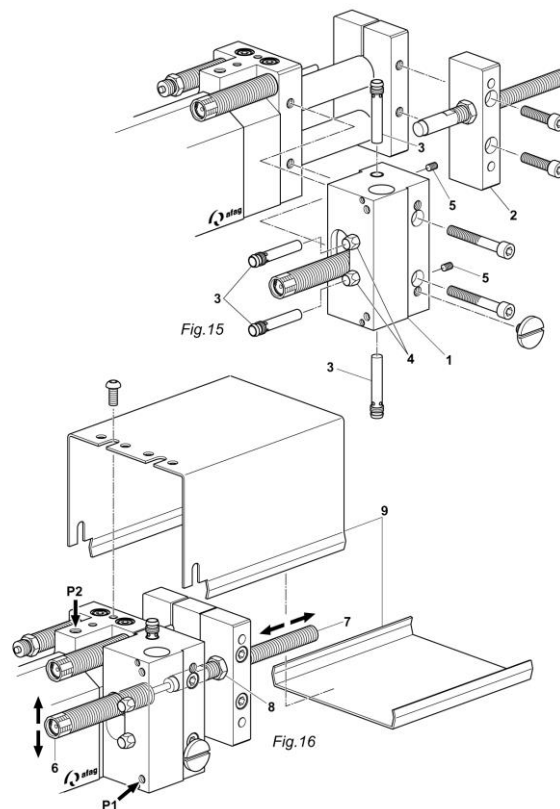

Fig. 13 Mounting variants with "narrow" or "wide" hand guard

6.4 Mounting the initiators



WARNING

Risk of explosion!

The initiators must not be used in an explosive environment!

- Only use the linear module and initiators in **non-hazardous** environments!
-

NOTICE

Risk of material damage due to use of incorrect stop screws!

Using unsuitable stop screws can damage the module.

- The 6,5 mm and 8x8 mm proximity switches can only be used with the stop screws of the AS series!
-
-



The initiators are not included in the scope of delivery!

Functional description

Plug-in and screwable 6.5 mm (Fig. 14, 1) or 8x8 mm (Fig. 14, 2) initiators with initiator holders (Fig. 14, 3) are used for end position detection of the LM.

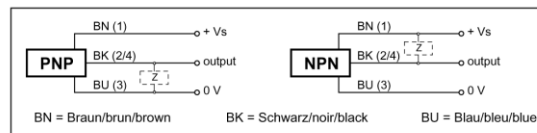
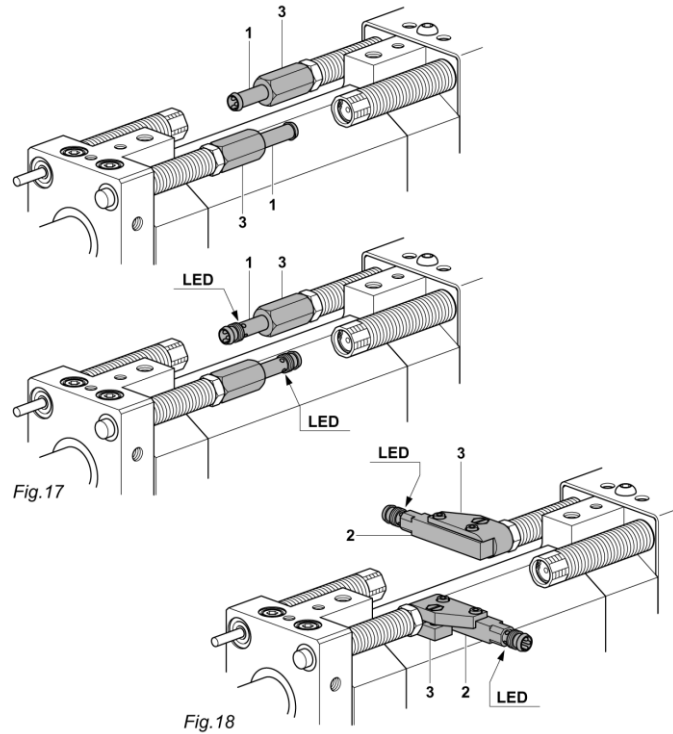

Fig. 14 Initiators for end position detection

A LED on the initiator is used for function monitoring during end position monitoring.

If the LED does not change its switching state during end position monitoring, the initiator is defective and must be replaced!

Depending on the controller type, the switching type PNP or NPN of the initiators must be determined (Fig. 16).

Technical data of initiators

Operating voltage range	10 – 30 VDC
Switching distance	1.5mm
The initiators are short-circuit and polarity reversal protected.	

6.4.1 Mounting the initiator 6.5 mm

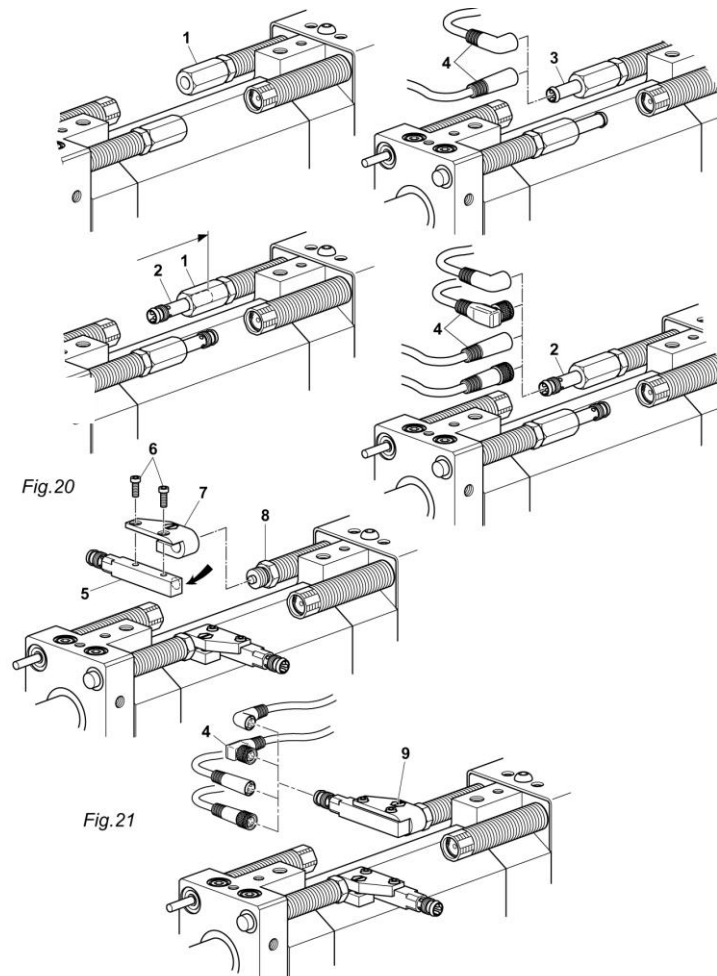

Fig. 15 Mounting initiator 6.5 mm

For assembly the initiator 6.5 mm proceed as follows:

1. Screw the initiator holder (Fig. 15, 1) onto the stop screw.
2. Insert the initiator (Fig. 15, 2) into the initiator holder as far as it will go.
3. Slightly tighten the initiator holder (Fig. 15, 1).
4. Mount the connector (Fig. 15, 4).
5. Carry out function check.
 - ⇒ The initiator 6.5 mm is mounted.

6.4.2 Mounting initiator 8x8 mm

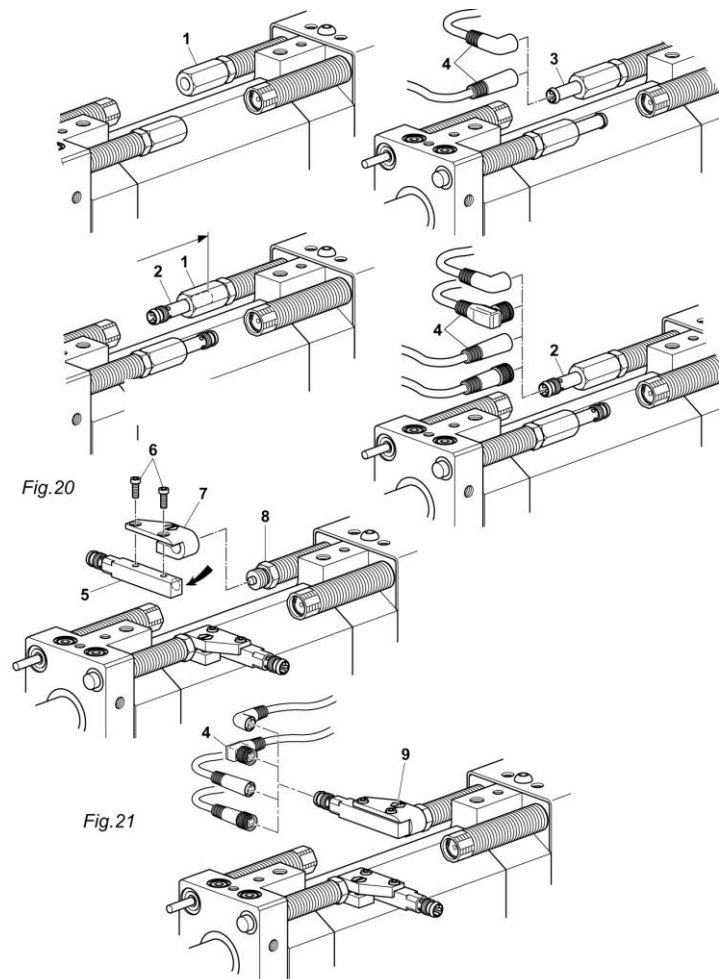

Fig. 16 Mounting initiator 8x8 mm

For assembly the initiator 8x8 mm proceed as follows:

1. Screw the initiator (Fig. 16, 5) onto the initiator holder (Fig. 16, 7) with screws (Fig. 16, 6).
2. Push the holder (Fig. 16, 7) with initiator onto the stop screw (Fig. 16, 8) as far as it will go.
3. Clamp with screw (Fig. 16, 9).
4. Mount the connector (Fig. 16, 4).
5. Carry out function check.
 - ⇒ The initiator 8x8 mm is mounted.



The switching point of the initiator must cover the hole of the initiator holder (see arrow)!

6.5 Pneumatic connections

WARNING



Risks by the pneumatic system!

When operating the linear module uncontrolled movements may occur which cause personal property damage. Ventilate the unit slowly.

- When connecting the compressed air supply for the first time, make sure that all compressed air throttles are closed.
- Ventilate the unit slowly.

Pneumatic connections LM 32

The pneumatic connections are located on top of the module (2 x G1/8").

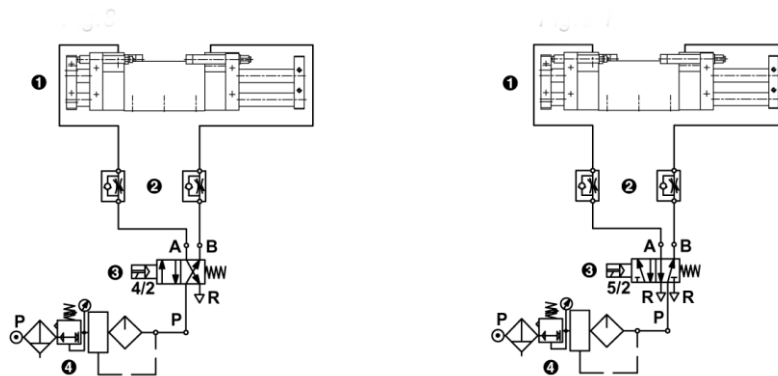

Fig. 17 Pneumatic connection linear module

1. Linear module LM 32
2. Throttle valve
3. Valve
4. Maintenance unit
- P. Pressurized air connection

Pneumatic connection diagram ZA intermediate stop module

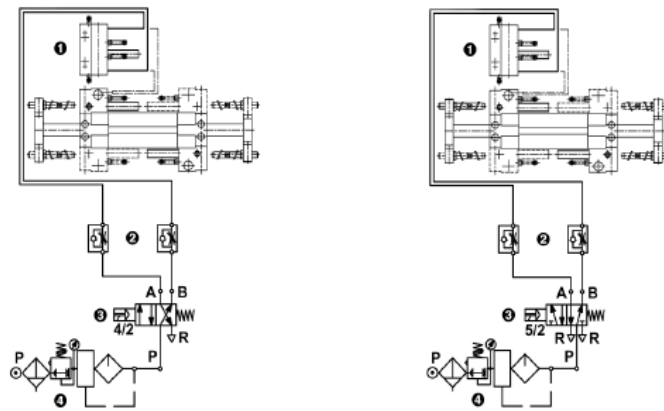

Fig. 18 Pneumatic connection diagram linear module



Minimum compressed air requirements acc. to ISO 8573-1:2010 (7.4.4)!

7 Commissioning

7.1 Safety instructions for commissioning

CAUTION



Danger of injury by moving components!

During normal operation, it must be ensured that the user cannot interfere with the working area of the linear module.

- The operator can provide suitable protective measures such as enclosures, light barrier or disconnecting the drive from the power supply.



Observe the safety instructions in ➔ Chapter 2 „Safety instructions“ of these assembly instructions!

7.2 Preparatory activities for commissioning



Before commissioning, adjust the shock absorber and stop screws so that the desired stroke is damped correctly.

7.2.1 Adjustment of stop screws AS 12/60

Procedure for setting the stop screws:

1. Pull out the protective unit (Fig. 19, 1).
2. Loosen screws (Fig. 19, 2) and remove screw (Fig.19, 3).
3. Pull the hand guard (Fig. 19, 4) upwards.
4. Loosen the locking screw (Fig. 19, 7, 8) and unscrew the shock absorber (Fig. 19, 5, 6) approx. 5 turns anticlockwise.
5. Apply compressed air at (P1).
 - The slide (Fig. 19, 9) moves onto the stop screw (Fig. 19, 10).
6. Loosen the locking screw (Fig. 19, 11).
7. Determine the rear position (X) of the stroke (H) by adjusting the stop screw (Fig. 19, 10).
8. Secure position with locking screw (Fig. 19, 11) (One turn = 1 mm).
9. Compressed air at (P2).
 - The slide (Fig. 19, 9) is equipped with a linear guide (Fig. 19, 12).
10. Loosen the locking screw (Fig. 19, 13).
11. Determine the front position (X1) of the stroke (H) by adjusting the stop screw (Fig. 19, 12).
12. Secure position with locking screw (Fig. 19, 13).
 - ⇒ The setting process is completed.

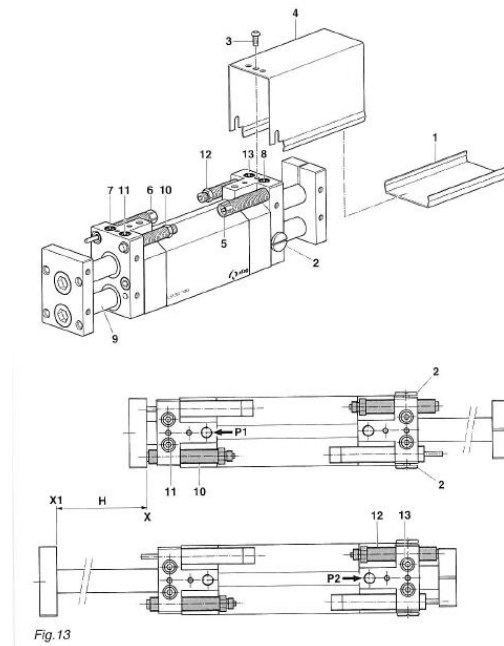

Fig. 19 Adjustment of stop screws AS 12/60



These stop screws AS 12/60 can be combined with an initiator holder and initiator switch D 6.5 mm or with an angle initiator holder 8x8 mm for end position detection.

7.2.2 Stroke adjustment



The stroke adjustment of the linear module is done by adjusting the stop screws 10 + 12.

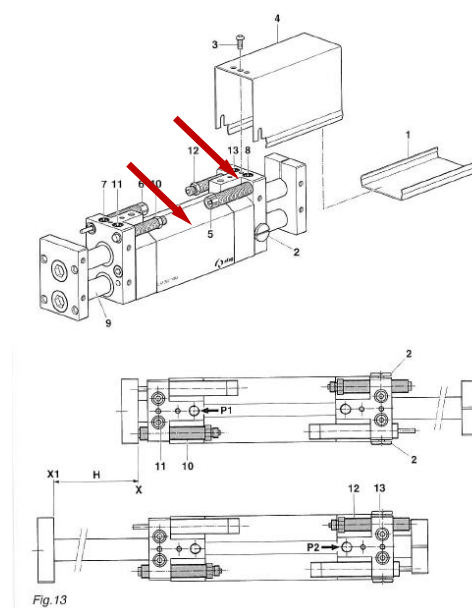

Fig. 20 Stop screws 10 and 12 for stroke adjustment

7.2.3 Adjustment of the shock absorber

In order to achieve a smooth movement sequence, the stroke (H) is braked in the end position against the stop screws by means of shock absorbers.



* From a stroke reduction of 25 mm it is recommended to fix the shock absorber with a nut M14x1 (art. no. 1101242) to avoid jamming of the SD ram!

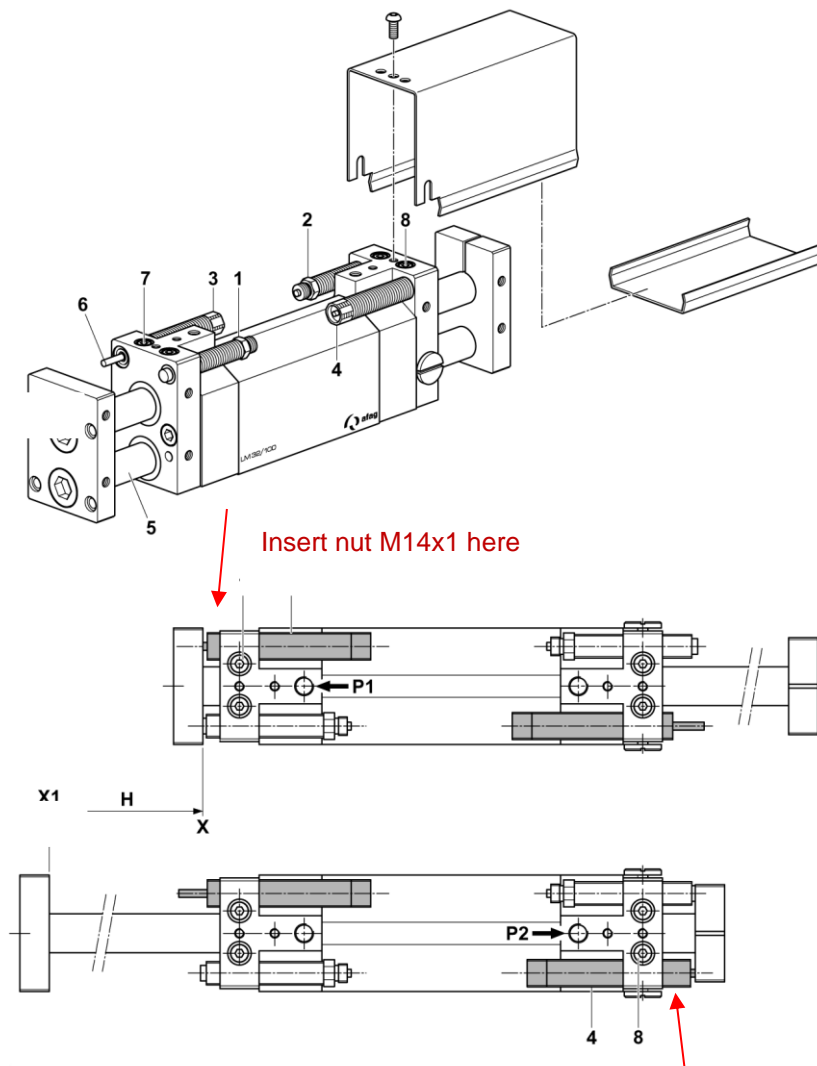

Fig. 21 Adjustment of the shock absorber

Insert nut M14x1 here

Procedure for adjusting the shock absorbers:

1. Adjust stroke (H) as described above (via stop screws 10 and 12).
 2. Compressed air at (P1). The slide (Fig. 21, 5) of the LM moves to the right until it is limited by the stop screw (Fig. 21, 1) in position (X).
 3. Screw in the shock absorber (Fig. 21, 3) clockwise [the shock absorber pin (Fig. 21, 6) is pressed into the shock absorber] until the slide (Fig. 21, 5) starts to move.
 4. Now unscrew the shock absorber (Fig. 21, 3) two turns anticlockwise and secure it with the stud screw (Fig. 21, 7)*. (One turn = 1mm).
 5. Compressed air at (P2). The slide (Fig. 21, 5) of the LM moves to the left until it is limited by the stop screw (Fig. 21, 2) in position (X1).
 6. Repeat the same procedure as under point 3-4 with shock absorber (Fig. 21, 4). Secure shock absorber with nut (Fig. 21, 8).
- ⇒ Setting of the shock absorbers are completed.

NOTICE
Risk of property damage by using the shock absorber as a stop!

If the shock absorber is used as a stop, the shock absorber can be damaged and become unusable.

- The stroke (H) must be limited by the stop screws!

7.3 First commissioning

Proceed carefully and follow the instructions step by step when commissioning the modules for the first time:

1. Slowly ventilate the entire system.
 2. Observe permissible values (➡ chap. 3 Technical data):
 - Payload
 - Operating pressure
 - Movement frequency
 - Load on the guidance system
 3. Make sure that there are no persons or tools in the working area of the modules.
 4. Perform test run:
 - Start with slow movements.
 - Then continue under normal operating conditions.
- ⇒ Commissioning is completed.

8 Fault elimination

8.1 Safety instructions for troubleshooting

WARNING



Danger of injury due to faulty troubleshooting!

Poorly performed troubleshooting work can lead to serious injuries and damage to property.

- Only use trained specialist personnel for troubleshooting.
- All work on the module must be carried out with the power supply cut off!



Also observe the safety instructions in  chap. 2 „Safety instructions“ in this manual.

8.2 Fault causes and remedy

Fault	Possible cause	Remedy:
Module does not retract or extend	<ul style="list-style-type: none"> ▪ No compressed air ▪ Module incorrectly connected to pneumatics 	<ul style="list-style-type: none"> ▪ Check connections ▪ Check connections
End position no signal	<ul style="list-style-type: none"> ▪ Limit stop screw incorrectly adjusted ▪ Initiator defect ▪ Cable break in sensor cable 	<ul style="list-style-type: none"> ▪ Correct the setting of the stop screw ▪ Replace initiator ▪ Replace proximity switch cable
Module hits the end positions	<ul style="list-style-type: none"> ▪ Shock absorber incorrectly adjusted ▪ Shock absorber defective ▪ No shock absorber available ▪ Exhaust flow control defective ▪ Lifting speed too high 	<ul style="list-style-type: none"> ▪ Readjust shock absorber ▪ Replace shock absorber ▪ Retrofitting of shock absorber ▪ Replace exhaust air throttle ▪ Adjust exhaust flow control
Payload swings in the end position	<ul style="list-style-type: none"> ▪ Lifting speed too high ▪ Suboptimal damping ▪ Unfavourable installation position ▪ Unfavourable type 	<ul style="list-style-type: none"> ▪ Adjust exhaust flow control ▪ Optimise damper type, stroke ▪ Adaptation of the construction ▪ Use larger type



Replace defective components exclusively with AFAG original spare parts!

9 Maintenance and repair

9.1 General notes

The following maintenance activities can ensure optimum operating condition of the linear modules.

9.2 Safety instructions for Maintenance and Repair

WARNING



Danger of injury due to improper maintenance!

Improperly carried out maintenance activities can cause considerable damage to property and serious injury.

- Only use trained specialist personnel to carry out the activities.
- Always wear personal protective equipment when carrying out maintenance and repair work!

CAUTION



Risk of injury from pneumatics!

When operating the modules uncontrolled movements may occur which cause personal injury or property damage.

- Only work on the linear module when the system is vented and deactivated!



Also observe the safety instructions in ➔ chap. 2 „Safety instructions“ in this manual.

9.3 Maintenance activities and maintenance intervals

9.3.1 Overview of the maintenance points



Observe the specified maintenance and care intervals. The intervals apply to normal operating conditions and are to be shortened accordingly for other conditions.

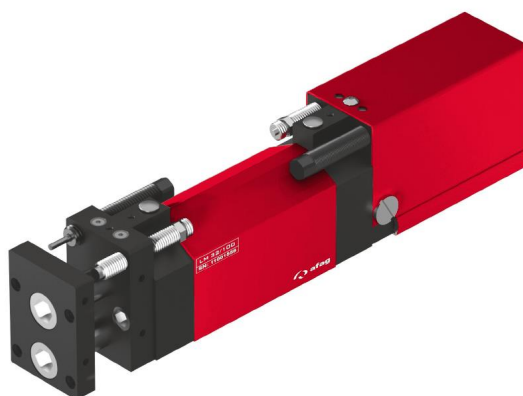





Fig. 22 Maintenance on linear module LM 32

No.	Maintenance point	Maintenance work	Interval	System [On/Off]	Remarks
1	Shock absorber and stop screws	check 	Regularly	[Off]	- <ul style="list-style-type: none">Check function, replace shock absorbers or stop screws if necessary.
2	Linear module	Cleaning 	Regularly	[Off]	In particular observe cleanliness of measuring tape <ul style="list-style-type: none">With lint-free, dry clothDo not spray module with water, do not use aggressive cleaning agents.
3	Guides and piston rods	Clean and lubricate 	monthly	[Off]	Only when used in an ionized air environment! Afag - standard: - Staburax NBU8EP (flat guides) - Blasolube 301 (piston rods)

NOTICE

Material damage due to incorrectly adjusted, defective or missing shock absorbers!

Incorrectly adjusted, missing or defective shock absorbers impair the function of the linear module and can lead to its destruction!

- Always operate the linear module with shock absorbers.
- Check shock absorbers for correct adjustment and function!

NOTICE

Risk of corrosion due to ionized air environment

If the linear modules are used in an ionised air environment, there is a risk that exposed parts could corrode.

- Regularly lubricate open guides and piston rods.
- Recommendation: monthly lubrication (➔ Overview 9.3.1).

9.3.2 Compressed air specifications

The linear modules are lifetime lubricated and can be operated with lubricated or non-lubricated compressed air.

Compressed air specification

Dry (condensation-free)

Filtered (40 µm filter for oil-lubricated air)

Filtered (5 µm filter for oil-lubricated air)

If the modules are operated with lubricated compressed air, we recommend that you use the following types of oil:

oil type

Festo Special Oil

Avia Avilub RSL 10

BP Energol HPL 10

Esso Spinesso 10

Shell Tellus Oel C 10

Mobil DTE 21

Blaser Blasol 154

Oil quantity: 5-10 drops of oil per 1000 ltr. Compressed air

Viscosity: 9 to 11 mm²/s (= cST) at 40°C, ISO class VG 10 acc. to ISO 3448

NOTICE

Risk of damage to property!

Before operating with oil-free air, the linear module must not have been operated with oiled air!

- After one-time operation with oiled compressed air, the linear module may no longer be operated with oil-free air.

9.3.3 Further maintenance

Further maintenance is not required, if the ambient conditions listed below are complied with:

- Clean working area.
- No use of splash water.
- No abrasive or process dust and vapours.
- Ambient conditions according to information in ➔ chap. 3 Technical data.

9.4 Spare and wear parts lists, repairs

Afag Automation AG offers a reliable repair service. Defective modules can be sent to Afag for warranty repair within the warranty period.



Please note that AFAG does not assume any warranty for the module that have not been replaced or repaired by AFAG!

After expiry of the warranty period, the customer may replace or repair defective modules or wear parts himself or send them to the Afag repair service.

CAUTION



Danger of injury when dismantling the linear module!

If pneumatic connections are disconnected under pressure, sudden rapid movements of moving parts can cause serious injuries!

- Only remove the modules when the system is vented and deactivated!
-



The instructions for replacing the wear parts are given without guarantee, as AFAG uses special assembly aids for the replacement.

9.4.1 Wear parts

After expiry of the official warranty, wear parts can also be replaced by the customer himself with the help of the corresponding wear parts.

When replacing the wearing parts, all wearing parts should be replaced together and properly so that the functional parts are not damaged.

Depending on the module stroke, the wear part sets are different. Please ensure that the correct set of wearing parts is ordered and fitted!

9.4.2 Wear parts set for LM 32-100, -200, -300, -400

Fig. 21.	Wear part set for all LM 32 module types	Order Number
<u>Item</u>	<u>Wear part set consisting of:</u>	<u>11011210</u>
10	2x rod seal (+ 2x O-ring)	
11	1x piston seal + (1x O-ring)	
12	2x O-Ring 34x1.5	
13	1x O-Ring 18x1	
14	1x guide ring d=32	
15	4x linear ball bearing	
21	2x retainer rings AS 20 x 1.2	

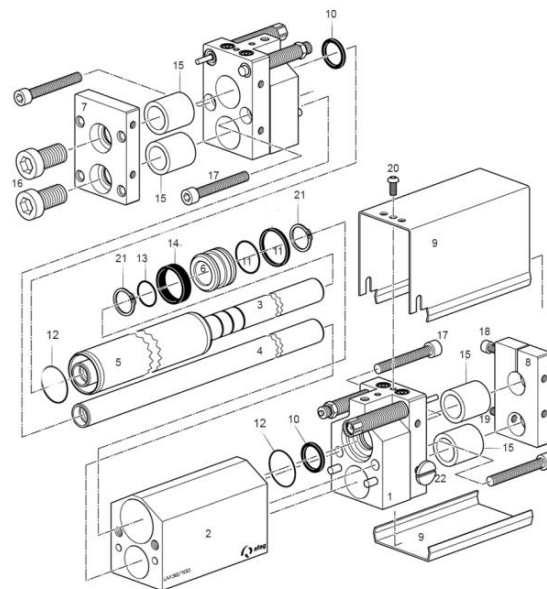

Fig. 23 Wear parts pos. 10 - 15 and 21 are included in the set

9.4.3 Replacing wear parts (LM 32)



We recommend that you replace all wear parts at the same time and carefully so that the functional parts are not damaged.

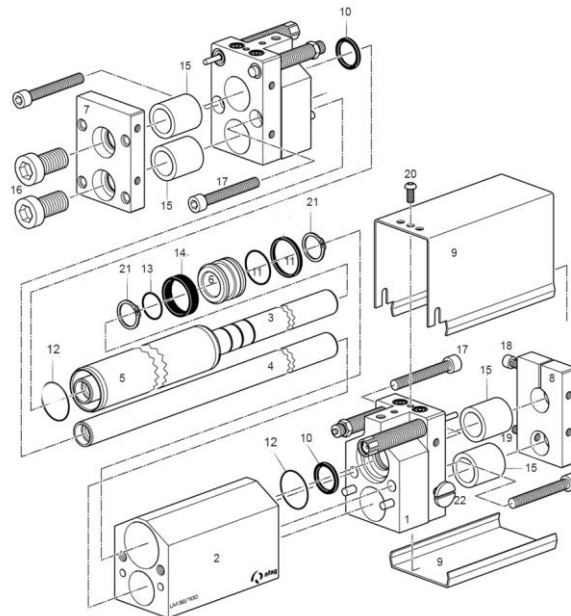

Fig. 24 Replacing the wear parts - LM 32

A) Procedure for dismounting:

1. Loosen screws (Fig. 24, 20), remove protective connection.
2. Loosen the screws (Fig. 24, 17) on the intermediate part (Fig. 24, 1) at the front and rear and remove them.
3. Loosen the screws (Fig. 24, 18 / 19).
4. Remove the plate at the back.
5. Pull the front plate with piston and guide rods and guide block out of the intermediate part.
6. Remove the cylinder tube from the piston rod (Fig. 24, 3).
7. Remove the retainer rings (Fig. 24, 21) on the piston rod.
8. Push off the piston.
9. Extend the front plate (Fig. 24, 7) with the piston (Fig. 24, 3) and guide rod (Fig. 24, 4) out of the guide block (Fig. 24, 1).
10. Slide the guide block off the guide rod (Fig. 24, 4) and piston rod (Fig. 24, 3).
11. Remove the wear parts on the piston (Fig. 24, 6).
12. Remove the O-rings and rod seal (Fig. 24, 10) in guide blocks (Fig. 24, 1).
13. Remove the O-rings (Fig. 24, 12) from the guide blocks (Fig. 24, 1).
14. Carefully press out the linear ball bearings from the guide blocks.
15. Clean all the individual parts.

B) Replace wear parts:

1. Shorten guide ring (Fig. 24, 14) for piston (Fig. 24, 6) by 1 mm with a side cutter.
2. Carefully fit the guide ring (Fig. 24, 14) onto the piston (Fig. 24, 6).
3. Carefully push the O-ring and piston seal (Fig. 24, 11) onto the piston (Fig. 24, 6)! (Do not damage the seal)!
4. Grease the linear ball bearings (Fig. 24, 15) (Blasolube 301) and carefully press them into the two guide blocks (Fig. 24, 1) (flush at the front)!
 - Sealing lips of the linear ball bearings (Fig. 24, 15) must face outwards.
5. Carefully insert the rod seal and O-ring (Fig. 24, 10) on both guide blocks into the grooves of the piston rod seals.
6. Carefully insert the O-ring (Fig. 24, 12) into the two guide blocks (1)!
 - ⇒ The wear parts are replaced.

9.4.4 Wear parts intermediate stop ZA
Procedure for assembly:

1. Push the front guide block (Fig. 24, 1) onto the piston and guide rod (Fig. 24, 3+4).
2. Fit a retainer ring on the piston rod.
3. Push the piston (Fig. 24, 6) with the black piston seal forwards onto the piston rod (Fig. 24, 3) up to the retainer ring.
4. Secure the piston (Fig. 24, 6) with the second retainer ring.
5. Grease the inside of the piston (Fig. 24, 6) and cylinder tube (Fig. 24, 5) with Blasolube 301 and slide it over the piston.
6. Push the intermediate part (Fig. 24, 2) over the cylinder tube (Fig. 24, 5).
7. Slide the guide block (Fig. 24, 1) over the piston rod (Fig. 24, 3) and guide rod (Fig. 24, 4).
8. Place the rear plate (Fig. 24, 8) over the piston rod (Fig. 24, 3) and guide rod (Fig. 24, 4).
9. Tighten the screw (Fig. 24, 18) and set screw (Fig. 24, 19) on the rear plate (Fig. 24, 8).
10. Insert and tighten the screws (Fig. 24, 17) on two guide blocks (Fig. 24, 1).
11. Carry out the sliding test manually.
 - Piston rod (Fig. 24, 3) and guide rod (Fig. 24, 4) should be movable without much resistance.
12. If the shifting works without resistance, the module can be connected to the compressed air.
13. Switch on the compressed air and check whether the module is tight.
14. If everything is in order, the module can be reinstalled.
15. A final inspection must be carried out before installation:
 - It must be possible to move the guide rods (Fig. 24, 3 + 4) with equal resistance in the base body (Fig. 24, 2).
 - A leak test must be carried out on the repaired module.
 - ⇒ The assembling process is completed.

9.4.1 Spare parts for ZA 32

Fig. 25	Wear parts set for ZA 32	Order Number
<u>Item</u>	<u>Spare parts part set consisting of:</u>	<u>11013003</u>
1	2x O-ring	
2	2x sealing ring	

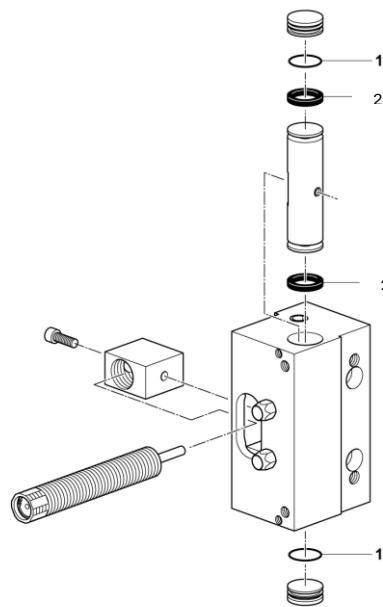

Fig. 25 Spare parts for ZA 32 - included in the set

10 Decommissioning, disassembly, disposal

The linear modules must be properly dismantled after use and disposed of in an environmentally friendly manner.

10.1 Safety instructions

WARNING



Risk of injury due to improper decommissioning, disassembly and disposal!

Improperly carried out activities can result in considerable material damage and serious injury.

- Only use trained specialist personnel to carry out the activities.
 - Disconnect the media supply (pneumatics) before removing the modules!
 - Only remove module when the controller is switched off and secured!
-



Also observe the safety instructions in ➔ chap. 2 „Safety instructions“ in this manual.

10.2 Decommissioning

If the linear modules are not used for a longer period, they must be properly commissioned and stored as described in ➔ chapter 4.5.

10.3 Disposal

The module must be disposed of properly at the end of their service life and the raw materials used must be recycled. Observe the legal regulations and company requirements.

The linear modules must not be disposed of as a complete unit. Dismantle the linear module and separate the various components according to type of material and dispose of them properly:

- Scrap the metallic materials.
- Hand over plastic parts for recycling.
- Sort the rest of the components by their material properties and dispose of them accordingly.

NOTICE

Risk to the environment due to incorrect disposal of the packaging material of the module!

Environmental damage can be caused by improper disposal of the modules.

- Electronic parts, electrical scrap, auxiliary and operating materials must be disposed of by approved specialist companies.
 - Information on proper disposal can be obtained from the responsible local authorities.
-

11 Declaration of incorporation

Declaration of incorporation

for partly completed machinery according to the Machinery Directive 2006/42/EC, Annex II, 1.B

The manufacturer hereby declares:

Afag Automation AG, Luzernstrasse 32, CH-6144 Zell

that the partly completed machine:

Product description	Linear module LM 32
Type:	LM 32/100, LM 32/200, LM 32/300, LM 32/400

complies with the following essential health and safety requirements of the Machinery Directive 2006/42/EC at the time of declaration: 1.1; 1.1.1; 1.1.2; 1.2.3; 1.3.3; 1.3.5; 1.3.6; 1.3.7; 1.3.9; 1.4.1; 1.5; 1.6; 1.6.1; 1.6.3; 1.6.4; 1.7; 1.7.4; 1.7.4.1; 1.7.4.2.

Harmonised standards applied, in particular:	
EN ISO 12100:2010	Safety of machinery - General design principles - Risk assessment and risk reduction.

Note: The partly completed machinery must not be put into service until the machinery into which it is to be incorporated has been declared in conformity with the provisions of Machinery Directive 2006/42/EC.

The manufacturer undertakes to transmit, in response to a reasoned request by the national authorities, relevant technical documentation for the partly completed machinery.

The relevant technical documentation was created according to Annex VII, Part B of the above-mentioned Directive .

Authorised representative for compiling the technical documentation:

Niklaus Röthlisberger, Product Manager, Afag Automation AG, CH-6144 Zell

Zell, 31.05.2023

Adrian Fuchser



CEO Afag Gruppe

Klaus Bott



CTO Afag Gruppe

Afag Automation AG
Luzernstrasse 32
6144 Zell
Switzerland
T +41 62 959 86 86
sales@afag.com

Afag GmbH
Werner-von-Braun-Straße 1
92224 Amberg
Germany
T +49 9621 650 27-0
sales@afag.com

Afag Engineering GmbH
Gewerbestraße 11
78739 Hardt
Germany
T +49 7422 560 03-0
sales@afag.com

Afag Automation Americas
Schaeff Machinery & Services LLC.
883 Seven Oaks Blvd, Suite 800
Smyrna, TN 37167
USA
T +1 615 730 7515
nashville@afag.com

Afag Automation APAC
Afag Automation Technology (Shanghai) Co., Ltd.
Room 102, 1/F, Bldg. 56, City Of Elite
No.1000, Jinhai Road, Pudong New District
Shanghai, 201206
China
T +86 021 5895 8065
shanghai@afag.com