

Assembly and operating instructions

EPS Handling Systems (electrical)



EPS mini YZ



EPS midi YZ



EPS maxi YZ



EPS giga YZ



EPS tera YZ



EPS mini XZ



EPS midi XZ



EPS maxi XZ



EPS mini XYZ



EPS midi XYZ



EPS maxi XYZ



EPS mini gantry XXYZ



EPS midi gantry XXYZ



EPS maxi gantry XXYZ



EPS mini gantry s



EPS midi gantry s



EPS maxi gantry s



EPS mini gantry h



EPS midi gantry h



EPS maxi gantry h

Translation of the Original Assembly Instructions EN

Dear Customer,

Thank you for choosing our products and placing your trust and confidence in our company!

These assembly and operating instructions contain all essential information you need about your product. Our aim is to provide the required information as concisely and clearly as possible. If, however, you still have any questions on the contents or suggestions, please do not hesitate to contact us. We are always grateful for any feedback.

Our team will also be glad to answer any further question you may have regarding the EPS handling system or other options.

We wish you every success with our products!

With kind regards

Your Afag team

© Subject to modifications

The EPS handling systems have been designed by Afag according to the state of the art. Due to the constant technical development and improvement of our products, we reserve the right to make technical changes at any time.

Updates of our documentations



Unlike the printed documents, our digital instructions manuals, product data sheets and catalogues are being continuously updated on our website.

Please keep in mind that the digital documents on our website are always the latest versions.

© Copyright 2022 Fa. Afag

All contents of the present assembly and operating instructions, in particular the texts, photographs and graphics, are protected by copyright. All rights reserved. No part of these assembly and operating instructions may be reproduced, distributed (made available to third parties), or transmitted in any form or by any means, including photocopying, recording, or other electronic or mechanical methods, without the prior written permission of Afag.

Afag Engineering GmbH
Gewerbestraße 11
D-78739 Hardt (Germany)

Tel.: +49 (0) 7422 56 00 30

e-mail: sales@afag.com

Internet: www.afag.com

Table of contents

1	General	8
1.1	Contents and purpose of these assembly instructions.....	8
1.2	Explanation of symbols.....	8
1.3	Additional symbols.....	9
1.4	Applicable documents	10
1.5	Warranty	10
1.6	Liability.....	10
2	Safety instructions	11
2.1	General.....	11
2.2	Intended use.....	11
2.3	Foreseeable misuse	11
2.4	Obligations of the operator and the personnel	12
2.4.1	Observe the assembly instructions	12
2.4.2	Obligations of the operating company.....	12
2.4.3	Obligations of the personnel	13
2.5	Personnel requirements	13
2.5.1	Personnel qualification	13
2.6	Personal protective equipment (PPE)	14
2.7	Changes and modifications	14
2.8	General hazards / residual risks.....	15
2.8.1	General hazards at the workplace	15
2.8.2	Danger due to electricity	15
2.8.3	Danger due to strong magnetic fields	16
2.8.4	Danger due to pneumatics	16
2.8.5	Danger due to high temperatures	16
2.8.6	Mechanical hazards	16
3	Technical data	17
3.1	EPS System mini YZ	17
3.1.1	Dimensioned drawing EPS mini YZ	17
3.1.2	Technical data EPS mini YZ	18
3.1.3	Module loads EPS mini YZ	19
3.2	EPS System midi YZ	20
3.2.1	Dimensioned drawing EPS midi YZ	20
3.2.2	Technical data EPS midi YZ	21
3.2.3	Module loads EPS midi YZ	22
3.3	EPS System maxi YZ	23
3.3.1	Dimensioned drawing EPS maxi YZ	23
3.3.2	Technical data EPS maxi YZ	24
3.3.3	Module loads EPS maxi YZ	25
3.4	EPS System giga YZ.....	26
3.4.1	Dimensioned drawing EPS giga YZ.....	26

3.4.2	Technical data EPS giga YZ	27
3.4.3	Module loads EPS giga YZ	28
3.5	EPS System tera YZ.....	29
3.5.1	Dimensioned drawing EPS tera YZ.....	29
3.5.2	Technical data EPS tera YZ.....	30
3.5.3	Module loads EPS tera YZ.....	31
3.6	EPS System mini XZ	32
3.6.1	Dimensioned drawing EPS mini XZ	32
3.6.2	Technical data EPS mini XZ	33
3.6.3	Module loads EPS mini XZ	34
3.7	EPS System midi XZ	35
3.7.1	Dimensioned drawing EPS midi XZ	35
3.7.2	Technical data EPS midi XZ	36
3.7.3	Module loads EPS midi XZ	37
3.8	EPS System maxi XZ	38
3.8.1	Dimensioned drawing EPS maxi XZ	38
3.8.2	Technical data EPS maxi XZ	39
3.8.3	Module loads EPS maxi XZ	40
3.9	EPS System mini XYZ.....	41
3.9.1	Dimensioned drawing EPS mini XYZ.....	41
3.9.2	Technical data EPS mini XYZ	42
3.9.3	Module loads EPS mini XYZ	43
3.10	EPS System midi XYZ.....	44
3.10.1	Dimensioned drawing EPS midi XYZ.....	44
3.10.2	Technical data EPS midi XYZ	45
3.10.3	Module loads EPS midi XYZ	46
3.11	EPS System maxi XYZ.....	47
3.11.1	Dimensioned drawing EPS maxi XYZ.....	47
3.11.2	Technical data EPS maxi XYZ	48
3.11.3	Module loads EPS maxi XYZ	49
3.12	EPS mini gantry XXYZ	50
3.12.1	Dimensioned drawing EPS mini gantry XXYZ	50
3.12.2	Technical data EPS mini gantry XXYZ.....	51
3.12.3	Module loads EPS mini gantry XXYZ.....	52
3.13	EPS midi gantry XXYZ	53
3.13.1	Dimensioned drawing EPS midi gantry XXYZ	53
3.13.2	Technical data EPS midi gantry XXYZ.....	54
3.13.3	Module loads EPS midi gantry XXYZ.....	55
3.14	EPS maxi gantry XXYZ	56
3.14.1	Dimensioned drawing EPS maxi gantry XXYZ	56
3.14.2	Technical data EPS maxi XYZ.....	57
3.14.3	Module loads EPS maxi gantry XXYZ	58
3.15	EPS mini gantry s.....	59
3.15.1	Dimensioned drawing EPS mini gantry s.....	59

3.15.2	Technical data EPS mini gantry s	60
3.15.3	Module loads EPS mini gantry s	61
3.16	EPS midi gantry s	62
3.16.1	Dimensioned drawing EPS midi gantry s	62
3.16.2	Technical data EPS midi gantry s	63
3.16.3	Module loads EPS midi gantry s	64
3.17	EPS maxi gantry s	65
3.17.1	Dimensioned drawing EPS maxi gantry s	65
3.17.2	Technical data EPS maxi gantry s	66
3.17.3	Module loads EPS maxi gantry s	67
3.18	EPS mini gantry h.....	68
3.18.1	Dimensioned drawing EPS mini gantry h.....	68
3.18.2	Technical data EPS mini gantry h.....	69
3.18.3	Module loads EPS mini gantry h.....	70
3.19	EPS midi gantry h.....	71
3.19.1	Dimensioned drawing EPS midi gantry h.....	71
3.19.2	Technical data EPS midi gantry h.....	72
3.19.3	Module loads EPS midi gantry h.....	73
3.20	EPS maxi gantry h.....	74
3.20.1	Dimensioned drawing EPS maxi gantry h.....	74
3.20.2	Technical data EPS maxi gantry h.....	75
3.20.3	Module loads EPS maxi gantry h.....	76
3.21	Overview of power supplies	77
4	Transport, packaging and storage	78
4.1	Safety instructions for transport.....	78
4.2	Transport	78
4.3	Packaging.....	78
4.4	Storage	79
5	Installation, assembly and setting	80
5.1	Safety instructions for installation and assembly	80
5.2	Required mounting material	81
5.3	Weight compensation	82
5.3.1	Weight compensation with MagSpring.....	82
5.3.2	Weight compensation with pneumatic cylinder	82
5.4	Interfaces of the axis controllers.....	83
5.4.1	Axis controller C11xx	83
5.4.2	Axis controller C12xx	85
5.4.3	Axis controller C1251-Mi-2S enhanced security	87
5.4.1	Safety functions survey	89
5.4.2	Available safety functions.....	90
5.4.3	Axis controller E12xx.....	91
5.5	Pin assignment and electrical connection data of the motors	93
5.5.1	Motor plug ES20, PEL20.....	94

5.5.2	Motor plug ES30, ES40, PDL30, PDL40	94
5.5.3	Motor plug RA40	95
5.5.4	Motor plug SE30.....	96
5.6	Connector assignment encoder Path measuring system on the controller	97
5.6.1	Connector assignment Sensor WMS MSA501	97
5.6.2	Connector assignment Sensor WMS MSK500, MSK1000	97
5.6.3	Connector assignment Sensor WMS MSA213C	98
5.6.4	Connector assignment Encoder IE3 (RA40/SE30)	98
5.7	Connector strip	99
6	Commissioning	100
6.1	Safety instructions for commissioning	100
6.2	Preparatory activities for commissioning	101
6.3	Commissioning of the modules	101
6.4	Settings.....	102
6.4.1	Set speeds on electric axes	102
6.4.2	Teaching the positions on electric axes	106
6.4.3	Adjusting damping and speeds on pneumatic modules.....	107
6.4.4	External position measuring system	107
6.4.5	MSA 501 calibration (only for retrofitting and replacement).....	109
6.4.6	Wizard LinMot Talk MAS501 (only for retrofitting and replacement) .	110
6.4.7	MSA213C calibration (only for retrofitting and replacement)	111
6.4.8	Wizard LinMot Talk MSA213C	115
6.4.9	External Absolute Position Measuring System Calibration Box.....	115
7	Fault elimination.....	116
7.1	Safety instructions for troubleshooting	116
7.2	Fault causes and remedy	116
8	Maintenance and repair	117
8.1	General notes	117
8.2	Safety instructions for Maintenance and Repair	117
8.3	Maintenance activities and maintenance intervals	118
8.3.1	Overview of the maintenance points	118
8.3.2	Further maintenance	118
8.4	Spare parts	119
8.4.1	Motor cable - Designation - Axes - Controller - Application	119
8.4.2	Motor cable.....	120
8.4.3	Servo controller	121
8.4.4	Position measuring system	121
8.4.5	MagSpring	122
9	Decommissioning and disposal	123
9.1	Safety instructions for decommissioning and disposal.....	123
9.2	Decommissioning	123
9.3	Disposal	123

10 Declaration of incorporation..... 124

1 General

1.1 Contents and purpose of these assembly instructions

These assembly instructions contain important information on assembly, commissioning, functioning and maintenance of the EPS handling system to ensure safe and efficient handling and operation.

Consistent compliance with these assembly instructions will ensure:

- permanent operational reliability of the EPS handling system,
- optimal functioning of the EPS handling system,
- timely detection and elimination of defects (thereby reducing maintenance and repair costs),
- Extension of the service life of the EPS handling system.

The illustrations in this manual shall provide you with a basic understanding of the module and may vary from the actual design of your module.

1.2 Explanation of symbols

The safety notes are marked by a pictogram and a signal word. The safety notes describe the extent of the hazard.

DANGER



Danger!

This safety note indicates an imminently hazardous situation which, if not avoided, will result in death or serious injury.

WARNING



Warning!

This safety note points out a potentially hazardous situation which, if not avoided, could result in death or serious injury.

CAUTION



Caution!

This safety note points out a potentially dangerous situation which, if not avoided, can result in minor or slight injuries.

NOTICE

This safety note points out a potentially dangerous situation which, if not avoided, can cause substantial damage to property and the environment.



This note contains important additional information as well as useful tips for safe, efficient and trouble-free operation of the EPS handling system.

Further warning signs:

Where applicable, the following standardised symbols are used in this manual to point out the various potential health risks.

	Warning - Dangerous electrical voltage.
	Warning: hot surfaces can cause burns upon contact.
	Warning - Risk of hand and finger injury due to uncontrolled movements of components.
	Warning - Magnetic field
	Warning - back injury due to heavy lifting.
	Warning - Risk of injury as a result of parts being flung out!
	Warning -high noise levels

1.3 Additional symbols

In these assembly instructions the following symbols are used to highlight instructions, results, references, etc.

Symbol	Description
1.	Instructions (steps ...)
⇒	Results of actions
↻	References to sections
■	Enumerations not ordered

1.4 Applicable documents



Each EPS handling system is accompanied by a safety information sheet. This information sheet must be read carefully by every person who carries out work on and with the EPS handling system.

Please also observe the installation instructions for the integrated modules!

1.5 Warranty

The warranty terms for Afag handling components and handling systems are the following:

- 24 months from initial operation and up to a maximum of 27 months from delivery.
- Wear parts are excluded from the warranty (The customer is entitled to a product free of defects. *This does also apply to defective accessories and wear parts. Normal wear and tear are excluded from the warranty.*)

The warranty covers the replacement or repair of defective Afag parts. Further claims are excluded.

The warranty shall expire in the following cases:

- Improper use of the handling system.
- Non-observance of the instructions regarding assembly, commissioning, operation and maintenance of the module.
- Improper assembly, commissioning, operation and maintenance.
- Repairs and design changes carried out without prior technical instructions of Afag.
- Removing the serial number from the product.
- Using the EPS handling system without shock absorbers or with defective shock absorbers
- Inadequate checking of wear parts.
- Non-observance of the EC Machinery Directive, the Accident Prevention Regulations, the Standards of the German Electrotechnology Association (VDE) and these safety and assembly instructions.
- Disasters caused by foreign bodies and force majeure.

1.6 Liability

No changes shall be made to the EPS handling system unless described in this instructions manual or approved in writing by Afag.

Afag accepts no liability for unauthorized changes or improper assembly, installation, commissioning, operation, maintenance or repair work.

2 Safety instructions

2.1 General

This chapter provides an overview of all important safety aspects to ensure safe and proper use of the EPS handling system and optimal protection of personnel.

Safe handling and trouble-free operation of the EPS handling system requires knowledge of the basic safety regulations.

Every person carrying out installation, commissioning, maintenance work or operating the EPS handling system must have read and understood the complete user manual, especially the chapter on safety instructions.

Beyond this, there are rules and regulations regarding accident prevention that are applicable to the place of installation which must be observed.

Improper use may result in danger to life and limb of the user or third parties or in damage to the automation system or other material assets.



Failure to follow the directions and safety instructions given in this instructions manual may result in serious hazards.

2.2 Intended use

EPS handling systems are designed for use in automation systems and are used exclusively for moving workpieces.

The pneumatic modules are exclusively intended for operation by means of compressed air (4-7 bar). The electric axes are designed exclusively for operation with original LinMot components (controller, cables...).

EPS handling systems may only be used in the ambient and operating conditions defined for these modules (➔Chapter 3 Technical data).

Any use beyond the described purpose is considered to be not in accordance with the intended use.



The intended use of the module also includes:

- observance of all instructions given in this instructions manual.
 - compliance with the inspection and maintenance work and the specifications in the data sheets,
 - using only original spare parts.
-

2.3 Foreseeable misuse

Any use other than or beyond the intended use described above is considered a misuse of the EPS handling system.

Especially the following use is considered a misuse:

- Use to move parts for which the EPS handling system is not designed.
- Use in unsuitable ambient and operating conditions.

WARNING



Risk of injury if the module is not used as intended!

The improper use of the EPS handling system poses a potential hazard to the personnel.

- The EPS handling system may only be used in a technically perfect condition in accordance with its intended use and the instructions in this manual as well as in compliance with the safety requirements!
- Any malfunctions, particularly those that could impair safety, must be eliminated immediately!



Risks can occur if the system is not used as intended. In the event of damages caused by improper use the following shall apply:

- the operating company shall be solely responsible for such damage, and
- AFAG does not accept any liability for damage caused by improper use.

2.4 Obligations of the operator and the personnel

2.4.1 Observe the assembly instructions

A basic prerequisite for safe and proper handling of the EPS handling system is a good knowledge of the basic safety instructions.



These assembly instructions, in particular the safety instructions contained therein, must be observed by all persons working with the EPS handling system.

2.4.2 Obligations of the operating company

In addition to the safety instructions given in this manual, the operating company must comply with the safety, accident prevention and environmental protection regulations valid for the field of application of the EPS handling system.

The operating company is required to use only personnel who:

- have the necessary professional qualifications and experience,
- are familiar with the basic rules regarding occupational safety and accident prevention,
- have been instructed in the correct handling of the EPS,
- have read and understood these assembly instructions.

The operating company is also required to:

- monitor on an ongoing basis that the personnel work safely considering any potential hazard involved and the assembly instructions are observed,
- ensure that the assembly instructions are always kept at hand at the installation in which the system are mounted,
- observe and communicate universally applicable laws and regulations regarding accident prevention and environmental protection,
- provide the necessary personal protective equipment (e.g. protective gloves) and instruct the personnel to wear it.

2.4.3 Obligations of the personnel

All personnel working with the rotary modules are required to:

- read and observe these assembly instructions, especially the chapter on safety,
- observe the occupational safety and accident prevention regulations,
- observe all safety and warning signs on the EPS handling system,
- refrain from any activity that might compromise safety and health.



In addition, the personnel must wear the personal protective equipment required for carrying out their work. (➡ Chapter 2.6).

2.5 Personnel requirements

2.5.1 Personnel qualification

The activities described in the assembly instructions require specific requisites at the level of professional qualifications of the personnel.

Personnel not having the required qualification will not be able to assess the risks that may arise from the use of the EPS handling system thus exposing himself and others to the risk of serious injury. Therefore, only qualified personnel may be permitted to carry out the described activities on the EPS handling system.

Persons whose ability to react is restricted due to the intake of medication or the like must not interact with the EPS handling system.

These installation instructions are intended for skilled personnel (installers, system integrators, maintenance personnel, technicians), electricians and operating personnel.

The following is a description of the professional skills (qualifications) required for carrying out the different activities:

Qualified personnel:

Qualified personnel with appropriate training who are qualified due to their special know-how and fully familiar with the machine and who have been given instructions on how to carry out the task entrusted to them safely.

Qualified electrician:

Persons who have obtained their electrical qualifications through appropriate professional training and complementary courses that enables them to identify risks and prevent possible hazards resulting from electricity.

Operator (trained personnel):

Authorized persons who due to their specialized professional training, expertise and experience are capable of identifying risks and preventing possible hazards arising from the use of the machine.





2.6 Personal protective equipment (PPE)

The personal protective equipment serves to protect the personnel from hazards affecting their safety and health at work.

When working on/with the EPS handling system, the personnel must wear the personal protective equipment assigned by the safety officer of the operating company or as required by safety regulations. In addition, the personnel is required to:

- wear the personal protective equipment provided by the operating company (employer),
- check the personal protective equipment for proper condition, and
- immediately notify the person responsible on site of any defects found on the personal protective equipment.

Personal protective equipment and the respective mandatory signs:

	<p><i>Protective clothing</i> is a close-fitting clothing specifically designed to protect personnel from hazards during work.</p>
	<p><i>Protective gloves</i> are specifically designed to protect the personnel against hand injuries (such as cuts, abrasion, burns).</p>
	<p><i>Safety shoes</i> are specifically designed to protect the personnel against foot injuries from crushing, falling objects or slipping on slippery surfaces.</p>
	<p>Hearing protectors are required to protect the personnel against excessive noise levels to prevent noise-induced hearing loss.</p>

2.7 Changes and modifications

No changes may be made to the EPS handling system which have not been described in these assembly instructions or approved in writing by Afag.

Afag accepts no liability for unauthorised changes or improper assembly, installation, commissioning, maintenance or repair work.

2.8 General hazards / residual risks

Despite the safe design of the EPS system and the technical protective measures taken, there still remain residual risks that cannot be avoided and which present a non-obvious residual risk when operating the EPS handling system.

Observe the safety instructions in this chapter and in the other sections of this manual to avoid damage to property and dangerous situations for the personnel.

2.8.1 General hazards at the workplace

The EPS system has been built according to the state-of-the-art and the applicable health and safety requirements. However, improper use of the EPS system may expose the personnel to the following hazards:

- danger to life and limb of the operator or third parties,
- on the EPS system itself,
- property damage.



Always keep the assembly instructions ready at hand at the workplace! Please, also observe:

- the general and local regulations on accident prevention and environmental protection,
- the safety information sheet for the EPS system.

CAUTION



Risk of injuries due to uncontrolled parts movements!

Incorrect control of the drives can trigger dangerous movements and cause personal injury or damage to property.

- Only qualified personnel may work with or on the EPS handling system.
- Only operate the EPS system with functioning monitoring systems!

2.8.2 Danger due to electricity



DANGER

Danger! Risk of electric shock!

If work on electrical components is required, ensure that the work is carried out properly, failure to do so will cause serious or fatal injuries.

- Work on the machine's electrical equipment may only be performed by skilled electrician or trained personnel under the supervision of a skilled electrician in accordance with all relevant electrical regulations.

2.8.3 Danger due to strong magnetic fields

DANGER



Danger due to strong magnetic fields.

Due to the strong magnetic fields, electronic devices such as pacemakers can be disturbed or their function impaired.

- Persons with a pacemaker must keep a safety distance of at least 50 cm. This must be ensured by means of a protective fence.
 - Provide the EPS system with appropriate warnings.
 - The personnel must be instructed accordingly.
-

2.8.4 Danger due to pneumatics

WARNING



Risks by the pneumatic system!

If work on electrical components is required, ensure that the work is carried out properly, failure to do so will cause serious or fatal injuries.

- Work on the machine's electrical equipment may only be performed by skilled electrician or trained personnel under the supervision of a skilled electrician in accordance with all relevant electrical regulations.
-

2.8.5 Danger due to high temperatures

CAUTION



Personal injury caused by hot surfaces.

During continuous operation of the EPS handling system, the surface heats up.

- Avoid direct contact if the system has been in operation.
 - Before touching hot surfaces without protective gloves, make sure that they have cooled down to ambient temperature or wear suitable protective equipment (gloves, long clothing ...).
-

2.8.6 Mechanical hazards

CAUTION



Danger of injury by moving components!

Limbs can be injured (bruises, contusions, broken bones) when reaching into the displacement range of moving components!

- Work on and with the EPS handling system may only be carried out by qualified personnel.
 - Never reach into the system during normal operation!
 - Fit a suitable protective fence to avoid encroachment on the driving area.
-

3 Technical data

3.1 EPS System mini YZ

3.1.1 Dimensioned drawing EPS mini YZ

Type	L
ES20-50-SL	191.5 mm
ES20-100-SL	285 mm
ES20-200	365 mm
ES20-300	495 mm

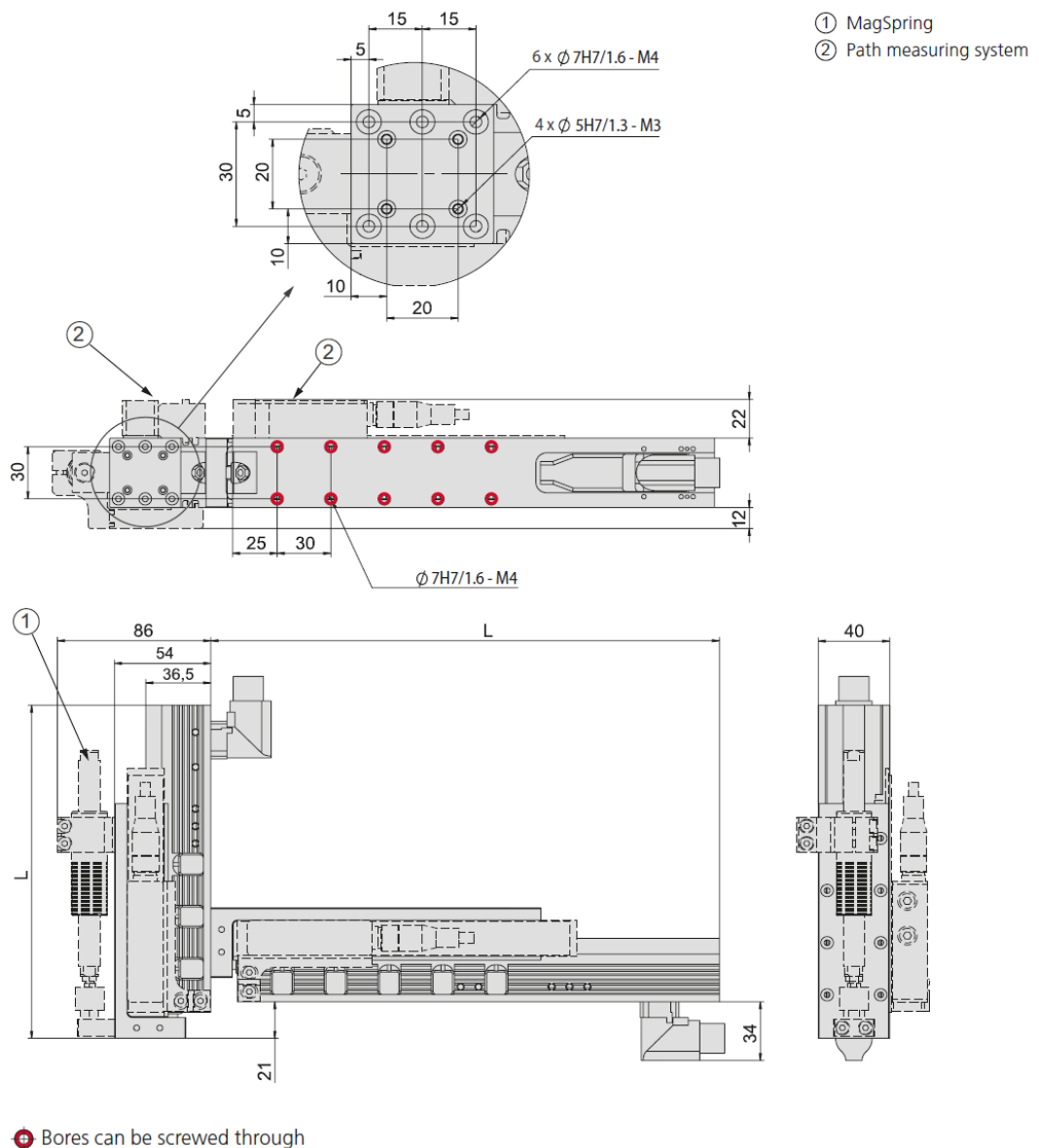

Fig. 1 Dimensioned drawing EPS mini YZ

3.1.2 Technical data EPS mini YZ

EPS mini YZ
Order number **50444428**

Drive type	electrical, linear motor
Repeat accuracy	± 0.05 mm
- with external path measuring system (1 µm)	± 0.02 mm
Temperature range	0 ... 50 °C
Control block with 5/3, 5/2 or vacuum units	up to 6 valves

Type	Y-axis	
Axis	ES20	ES20
Stroke horizontal	50 mm	100, 200, 300 mm
Maximum speed	6.8 m/s	4.8 m/s
Peak force	67 N	137 N
Permanent force	15 N	31 N

Type	Z-axis	
Axis	ES20	ES20
Stroke vertical	50 mm	100, 200, 300 mm
Maximum speed	6.8 m/s	4.8 m/s
Peak force	67 N	137 N
Permanent force	15 N	31 N

Included in the delivery *

- 2x Ø 5h6 Centring sleeves
- 4x Ø 7h6 Centring sleeves
- MagSpring or compensation spring
- Hose or drag chain
- Motor cable
- Completely wired
- Controller parametrised

Accessories

- (Catalogue HT accessories)
- Console
 - Valve block
- (Catalogue HT components linear)
- Path measuring system
- (Catalog HT components gripping/rotating)
- Rotary modules
 - Gripper modules

* Deviations possible depending on installed peripherals

3.1.3 Module loads EPS mini YZ

Type	ES20-SL	ES20
Dynamic torque Mx	5 Nm	5 Nm
Dynamic torque My	25 Nm	50 Nm
Dynamic torque Mz	25 Nm	50 Nm

Payload (centric)					
Stroke Y	50 mm	100 mm	200 mm	300 mm	
Stroke Z					
50 mm	3 kg	3 kg	2 kg	1 kg	
100 mm	3 kg	2 kg	1 kg	0.5 kg	
200 mm	2 kg	1 kg	-	-	
300 mm	1 kg	-	-	-	

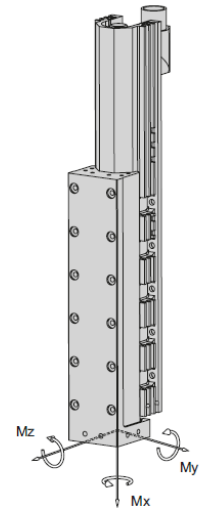

Cycle times EPS mini YZ for Pick & Place

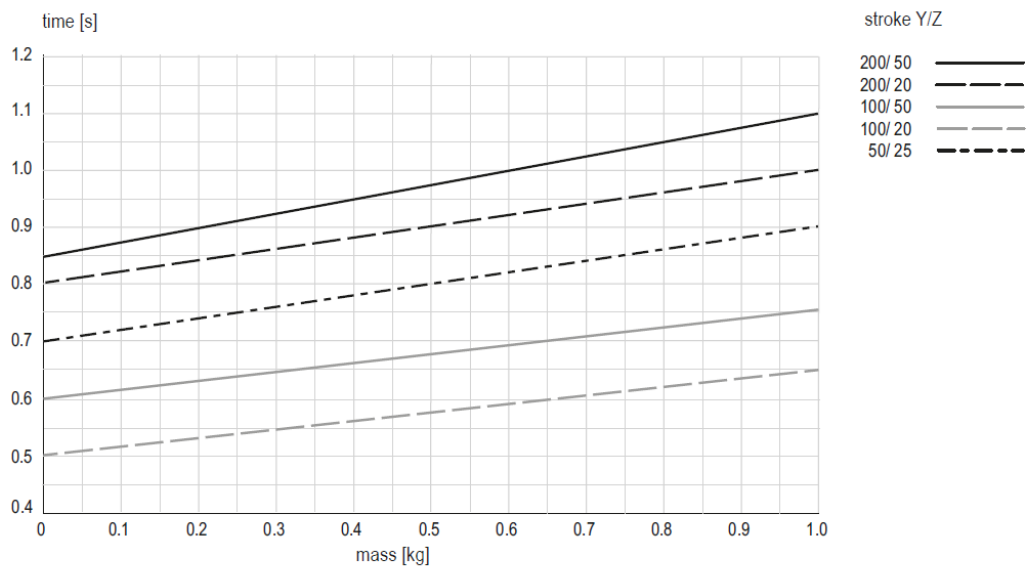

Times including 2 x 100 ms gripping time

Comment:

The values in the chart correspond to a Pick-and-Place cycle (6 subsequent movements + 2 x 100 ms gripping time). The indicated mass is centrally installed at the vertical linear unit. Standstill times of handling permit shorter movement times. In exceptions, e.g. at eccentric mass or high requirements to accuracy, the value may be exceeded.

3.2 EPS System midi YZ

3.2.1 Dimensioned drawing EPS midi YZ

Type	L
ES20-050-SL	191.5 mm
ES20-100-SL	285 mm
ES20-200	365 mm
ES20-300	495 mm

Type	B
ES30-050-SL	288 mm
ES30-100-SL	328 mm
ES30-100	328 mm
ES30-200-SL	428 mm
ES30-200	428 mm
ES30-300	528 mm
ES30-400	628 mm
ES30-500	728 mm

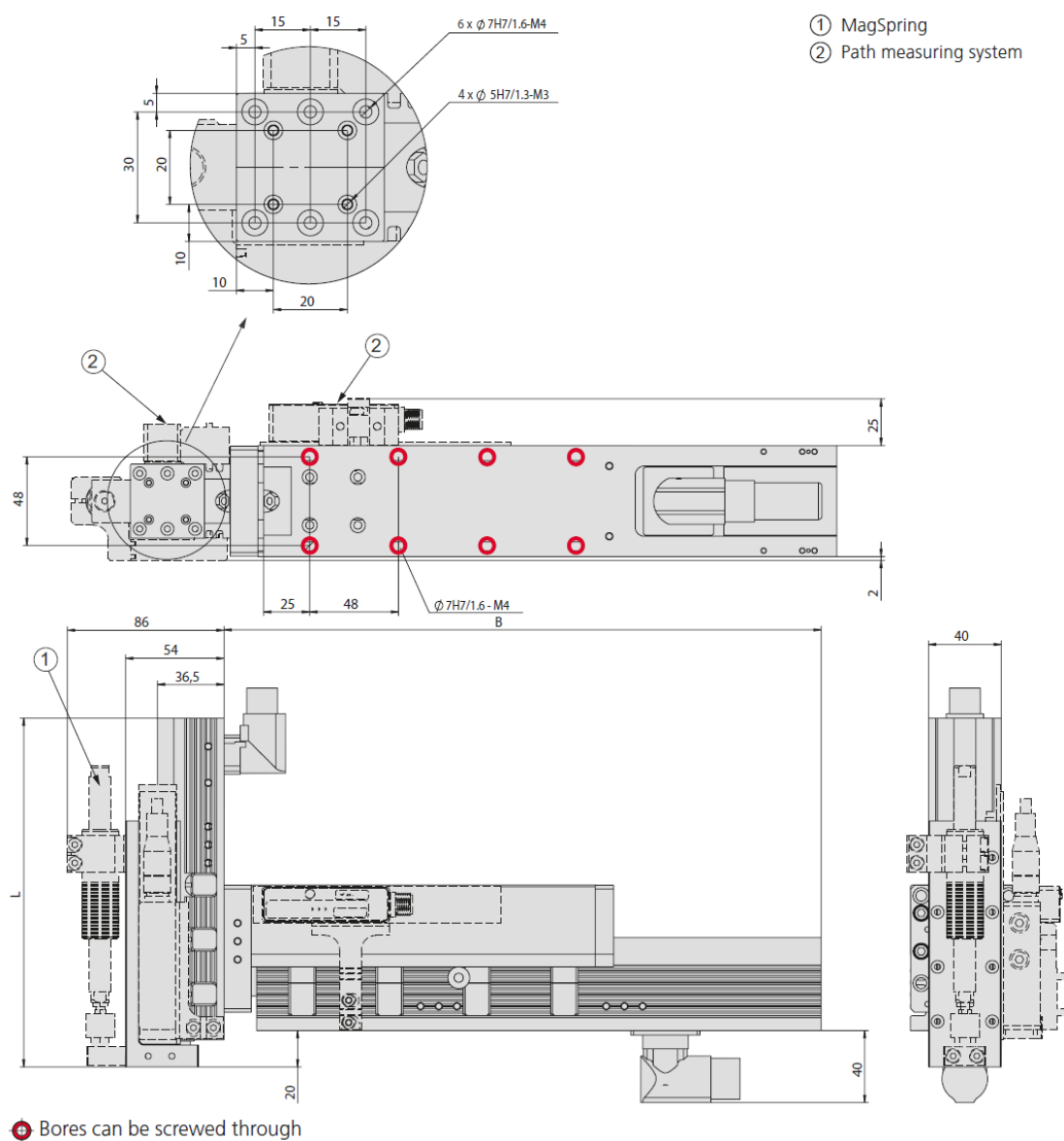

Fig. 2 Dimensioned drawing EPS midi YZ

3.2.2 Technical data EPS midi YZ



EPS midi YZ

Order number 50444429

Drive type	electrical, linear motor
Repeat accuracy	± 0.05 mm
- with external path measuring system (1 µm)	± 0.02 mm
Temperature range	0 ... 50 °C
Control block with 5/3, 5/2 or vacuum units	up to 6 valves

Type	Y-axis
Axis	ES30
Stroke horizontal	50, 100, 200, 300, 400, 500 mm
Maximum speed	3.2 m/s
Peak force	255 N
Permanent force	51 N

Type	Z-axis	
Axis	ES20	ES20
Stroke vertical	50 mm	100, 200, 300 mm
Maximum speed	6.8 m/s	4.8 m/s
Peak force	67 N	137 N
Permanent force	15 N	31 N

Included in the delivery *

- 2x Ø 5h6 Centring Sleeves
- 2x Ø 7h6 Centring Sleeves
- 2x Ø 9h7 Centring Sleeves
- MagSpring or compensation spring
- Hose or drag chain
- Motor cable
- Completely wired
- Controller parametrised

* Deviations possible depending on installed peripherals

Accessories

- (Catalogue HT accessories)
- Console
 - Valve block
- (Catalogue HT components linear)
- Path measuring system
- (Catalogue HT components gripping/rotating)
- Rotary module
 - Gripper module

3.2.3 Module loads EPS midi YZ

Type	ES20-SL	ES20
Dynamic torque Mx	5 Nm	5 Nm
Dynamic torque My	25 Nm	50 Nm
Dynamic torque Mz	25 Nm	50 Nm

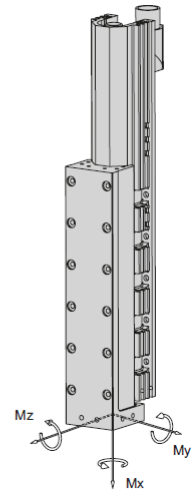

Payload (centric)							
Stroke Y	50 mm	100 mm	200 mm	300 mm	400 mm	500 mm	
Stroke Z							
50 mm	3 kg	5 kg	5 kg	4 kg	3 kg	2 kg	
100 mm	5 kg	5 kg	4 kg	3 kg	2 kg	1 kg	
200 mm	5 kg	4 kg	3 kg	2 kg	1 kg	0.5 kg	
300 mm	4 kg	3 kg	2 kg	1 kg	0.5 kg	0.5 kg	

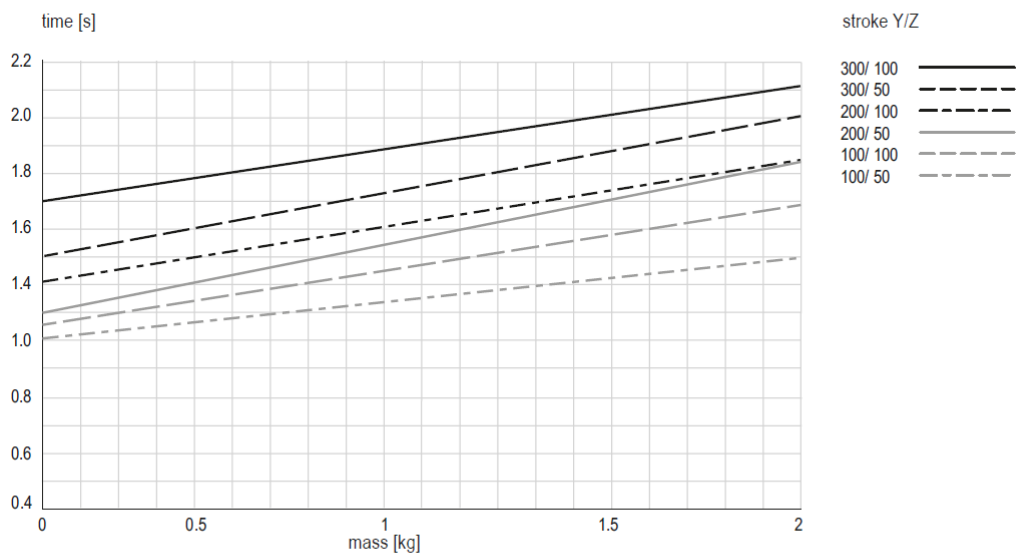
Cycle times EPS midi YZ for Pick & Place

Times including 2 x 100 ms gripping time

Comment:

The values in the chart correspond to a Pick-and-Place cycle (6 subsequent movements + 2 x 100 ms gripping time). The indicated mass is centrally installed at the vertical linear unit. Standstill times of handling permit shorter movement times. In exceptions, e.g. at eccentric mass or high requirements to accuracy, the value may be exceeded.

3.3 EPS System maxi YZ

3.3.1 Dimensioned drawing EPS maxi YZ

Type	L
ES30-050-SL	288 mm
ES30-100-SL	328 mm
ES30-100	328 mm
ES30-200-SL	428 mm
ES30-200	428 mm
ES30-300	528 mm
ES30-400	628 mm
ES30-500	728 mm

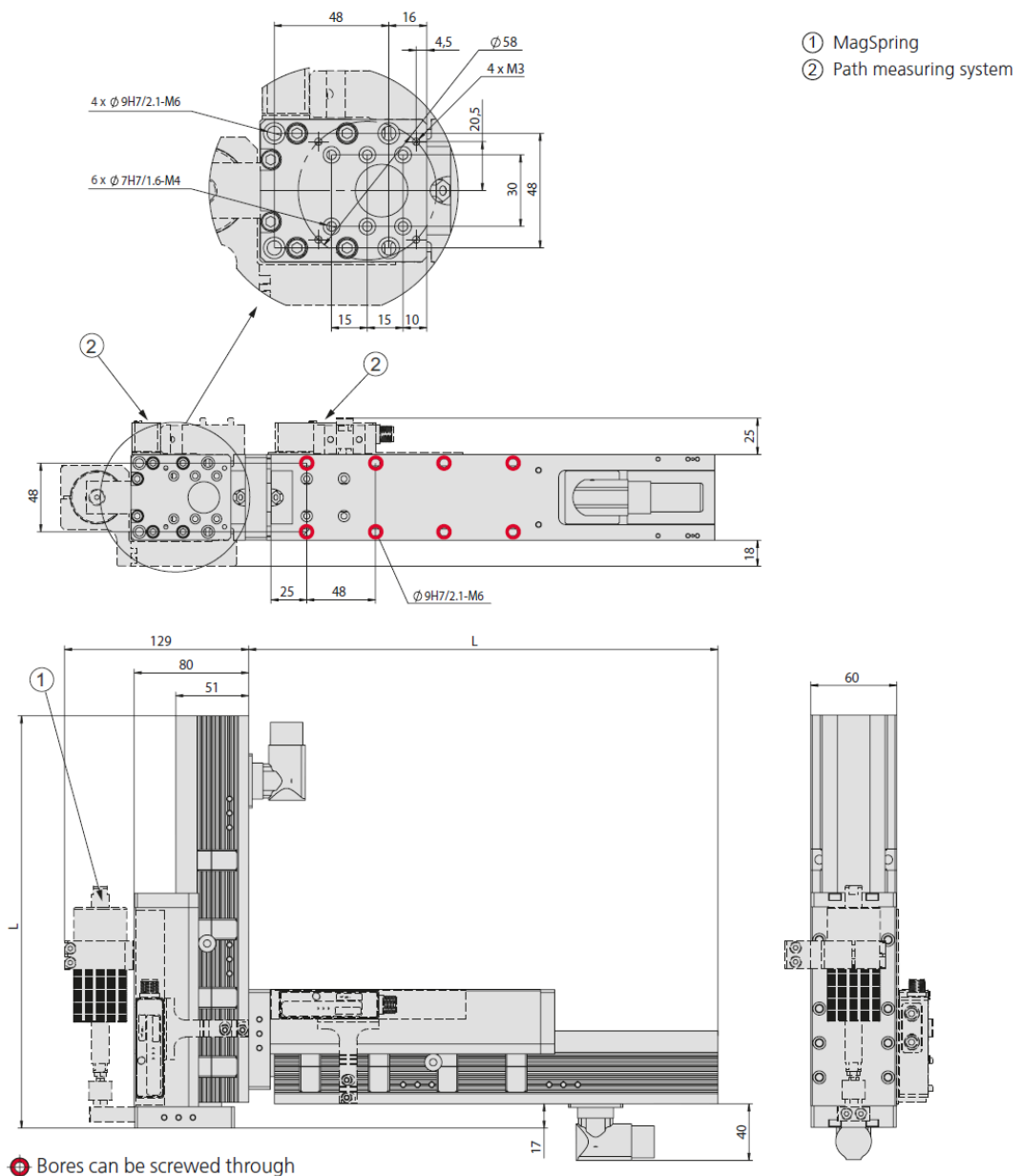

Fig. 3 Dimensioned drawing EPS maxi YZ

3.3.2 Technical data EPS maxi YZ

EPS maxi YZ
Order number **50444430**

Drive type	electrical, linear motor
Repeat accuracy	± 0.05 mm
- with external path measuring system (1 µm)	± 0.02 mm
Temperature range	0 ... 50 °C
Control block with 5/3, 5/2 or vacuum units	up to 6 valves

Type	Y-axis
Axis	ES30
Stroke horizontal	50, 100, 200, 300, 400, 500 mm
Maximum speed	3.2 m/s
Peak force	255 N
Permanent force	51 N

Type	Z-axis
Axis	ES30
Stroke vertical	50, 100, 200, 300, 400, 500 mm
Maximum speed	3.2 m/s
Peak force	255 N
Permanent force	51 N

Included in the delivery *

- 2x Ø 7h6 Centring sleeves
- 4x Ø 9h7 Centring sleeves
- MagSpring
- Hose or drag chain
- Motor cable
- Completely wired
- Controller parametrised

Accessories

- (Catalogue HT accessories)
- Console
 - Valve block
- (Catalogue HT components linear)
- Path measuring system
- (Catalogue HT components gripping/rotating)
- Rotary modules
 - Grpper modules

* Deviations possible depending on installed peripherals

3.3.3 Module loads EPS maxi YZ

Type	ES30-SL	ES30
Dynamic torque Mx	30 Nm	30 Nm
Dynamic torque My	40 Nm	80 Nm
Dynamic torque Mz	40 Nm	80 Nm

Payload (centric)							
Stroke Y	50 mm	100 mm	200 mm	300 mm	400 mm	500 mm	Stroke Z
50 mm	8 kg	7 kg	6 kg	5 kg	4 kg	3 kg	
100 mm	7 kg	6 kg	5 kg	4 kg	3 kg	2 kg	
200 mm	6 kg	5 kg	4 kg	3 kg	2 kg	1 kg	
300 mm	5 kg	4 kg	3 kg	2 kg	1 kg	0.5 kg	
400 mm	4 kg	3 kg	2 kg	1 kg	0.5 kg	-	
500 mm	3 kg	2 kg	1 kg	0.5 kg	-	-	

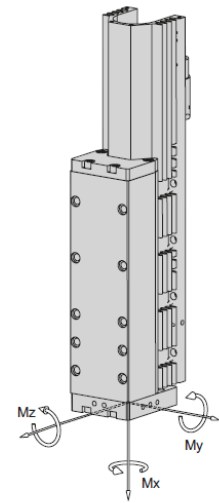

Cycle times EPS maxi YZ for Pick & Place

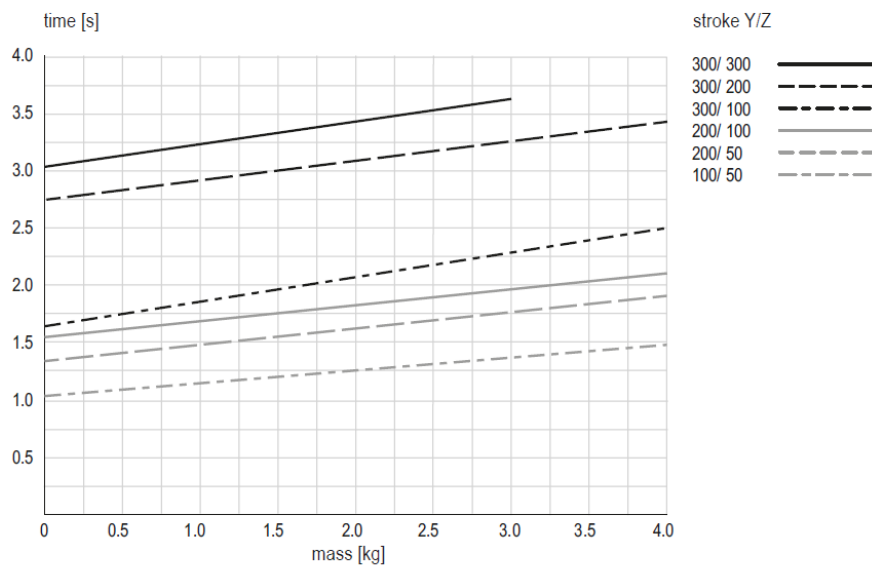

Times including 2 x 100 ms gripping time

Comment:

The values in the chart correspond to a Pick & Place cycle (6 subsequent movements + 2 x 100 ms gripping time). The indicated mass is centrally installed at the vertical linear unit. Standstill times of handling permit shorter movement times. In exceptions, e.g. at eccentric mass or high requirements to accuracy, the value may be exceeded.

3.4 EPS System giga YZ

3.4.1 Dimensioned drawing EPS giga YZ

Type	L	Type	B
ES30-50-SL	288 mm	ES40-100-SL	442 mm
ES30-100-SL	328 mm	ES40-100	449 mm
ES30-100	328 mm	ES40-100-HP-SL	532 mm
ES30-200-SL	428 mm	ES40-100-HP	532 mm
ES30-200	428 mm	ES40-200	549 mm
ES30-300	528 mm	ES40-200-HP	652 mm
ES30-400	628 mm	ES40-300	649 mm
ES30-500	728 mm	ES40-300-HP	742 mm
		ES40-400	749 mm
		ES40-400-HP	832 mm
		ES40-500	908 mm
		ES40-500-HP	952 mm

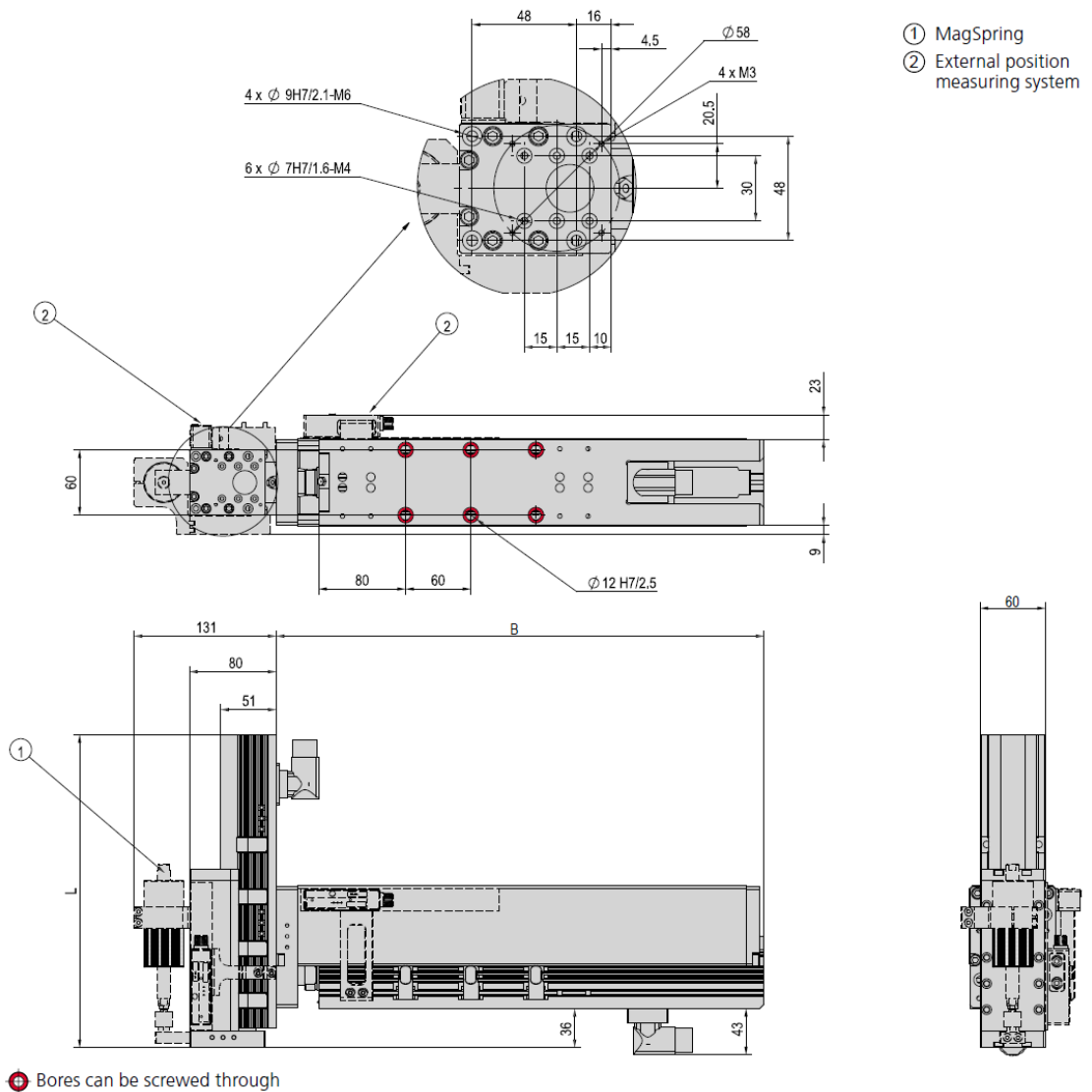

Fig. 4 Dimensioned drawing EPS giga YZ

3.4.2 Technical data EPS giga YZ

EPS giga YZ

Order number **50494324**

Drive type	electrical, linear motor
Repeat accuracy	± 0.05 mm
- with external path measuring system (1 µm)	± 0.02 mm
Temperature range	0 - 50 °C
Control block with 5/3, 5/2 or vacuum units	up to 6 valves

Type	Y-axis	
Axis	ES40	ES40-HP
Stroke horizontal	100, 200, 300, 400, 500 mm	100, 200, 300, 400, 500 mm
Maximum speed	3 m/s	2 m/s
Peak force	550 N	1024 N
Permanent force	145 N	203 N

Type	Z-axis	
Axis	ES30	
Stroke horizontal	50, 100, 200, 300, 400, 500 mm	
Maximum speed	3.2 m/s	
Peak force	255 N	
Permanent force	51 N	

Included in the delivery *

- 2x Ø7x3 centring sleeves
- 2x Ø9x4 centring sleeves
- 2x Ø12x4.8 centring sleeves
- Mass compensation
- Hose or drag chain
- Motor cable
- Completely wired
- Controller parametrised

* Deviations possible depending on installed peripherals

Accessories

- Console
- Valve block
(Catalogue HT components linear)
- External position measuring system
(Catalogue HT components gripping/rotating)
- Rotary modules
- Gripper modules

3.4.3 Module loads EPS giga YZ

Type	ES30-SL	ES30
Max. dynamic torque Mx	30 Nm	30 Nm
Max. dynamic torque My	40 Nm	80 Nm
Max. dynamic torque Mz	40 Nm	80 Nm

Payload (centric)						
Stroke Y	100 mm	200 mm	300 mm	400 mm	500 mm	
Stroke Z						
50 mm	15 kg	15 kg	12.5 kg	10 kg	9 kg	
100 mm	15 kg	15 kg	12.5 kg	10 kg	9 kg	
200 mm	15 kg	12.5 kg	10 kg	9 kg	8 kg	
300 mm	12.5 kg	10 kg	9 kg	8 kg	7.5 kg	
400 mm	10 kg	9 kg	8 kg	7.5 kg	5 kg	
500 mm	9 kg	8 kg	7.5 kg	5 kg	3 kg	

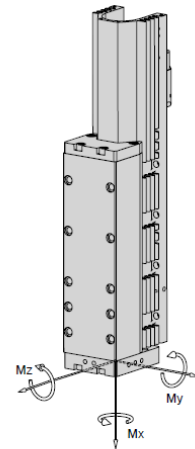
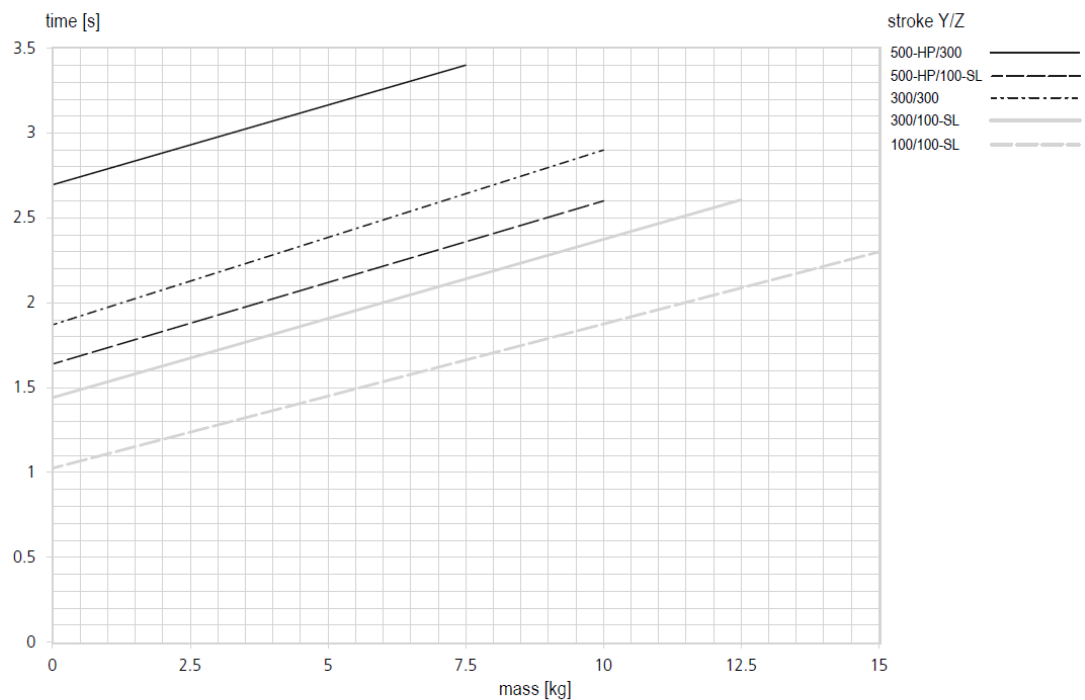
Cycle times EPS giga YZ for Pick & Place

Times including 2 x 100 ms gripping time

Comment:

The values in the chart correspond to a Pick & Place cycle (6 subsequent movements + 2 x 100 ms gripping time). The indicated mass is centrally installed at the vertical linear unit. Standstill times of handling permit shorter movement times. In exceptions, e.g. at eccentric mass or high requirements to accuracy, the value may be exceeded.

3.5 EPS System tera YZ

3.5.1 Dimensioned drawing EPS tera YZ

Type	L
ES40-100-SL	442 mm
ES40-100	449 mm
ES40-100-HP-SL	532 mm
ES40-100-HP	532 mm
ES40-200	549 mm
ES40-200-HP	652 mm
ES40-300	649 mm
ES40-300-HP	742 mm
ES40-400	749 mm
ES40-400-HP	832 mm
ES40-500	908 mm
ES40-500-HP	952 mm

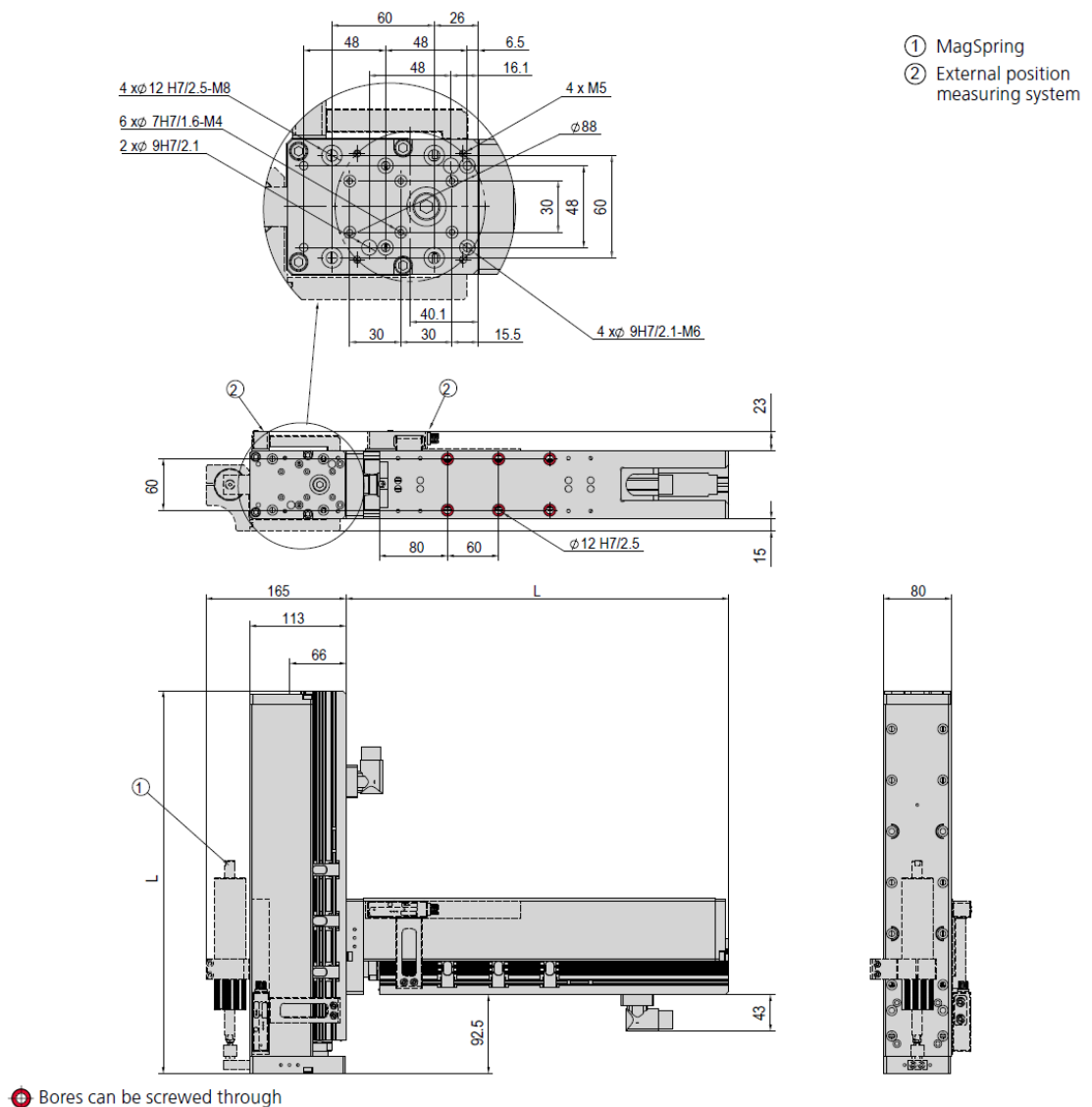

Fig. 5 Dimensioned drawing EPS tera YZ

3.5.2 Technical data EPS tera YZ

EPS tera YZ

Order number **50494325**

Drive type	electrical, linear motor
Repeat accuracy	± 0.05 mm
- with external path measuring system (1 µm)	± 0.02 mm
Temperature range	0 - 50 °C
Control block with 5/3, 5/2 or vacuum units	up to 6 valves

Type	Y-axis	
Axis	ES40	ES40-HP
Stroke horizontal	100, 200, 300, 400, 500 mm	100, 200, 300, 400, 500 mm
Maximum speed	3 m/s	2 m/s
Peak force	550 N	1024 N
Permanent force	145 N	203 N

Type	Z-axis	
Axis	ES40	ES40-HP
Stroke horizontal	100, 200, 300, 400, 500 mm	100, 200, 300, 400, 500 mm
Maximum speed	3 m/s	2 m/s
Peak force	550 N	1024 N
Permanent force	145 N	203 N

Included in the delivery *

- 2x Ø7x3 centring sleeves
- 2x Ø9x4 centring sleeves
- 4x Ø12x4.8 centring sleeves
- Mass compensation
- Hose or drag chain
- Motor cable
- Completely wired
- Controller parametrised

* Deviations possible depending on installed peripherals

Accessories

- Console
- Valve block
(Catalogue HT components linear)
- External position measuring system
(Catalogue HT components gripping/rotating)
- Rotary modules
- Gripper modules

3.5.3 Module loads EPS tera YZ

Type	ES40-SL	ES40
Max. dynamic torque Mx	35 Nm	45 Nm
Max. dynamic torque My	80 Nm	180 Nm
Max. dynamic torque Mz	80 Nm	180 Nm

Payload (centric)						
Stroke Y	100 mm	200 mm	300 mm	400 mm	500 mm	
Stroke Z						
100 mm	20 kg	20 kg	15 kg	12.5 kg	10 kg	
200 mm	20 kg	15 kg	12.5 kg	10 kg	9 kg	
300 mm	15 kg	12.5 kg	10 kg	9 kg	8 kg	
400 mm	12.5 kg	10 kg	9 kg	8 kg	5 kg	
500 mm	10 kg	9 kg	8 kg	5 kg	3 kg	

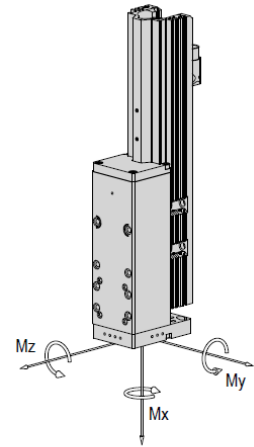
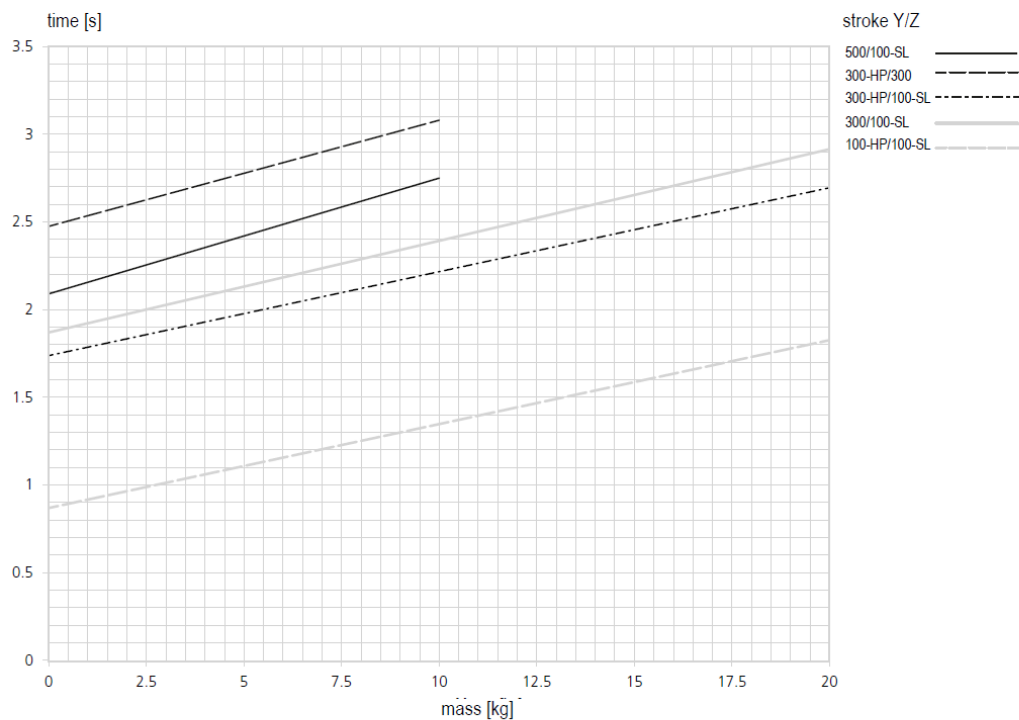
Cycle times EPS tera YZ for Pick & Place

Times including 2 x 100 ms gripping time

Comment:

The values in the chart correspond to a Pick & Place cycle (6 subsequent movements + 2 x 100 ms gripping time). The indicated mass is centrally installed at the vertical linear unit. Standstill times of handling permit shorter movement times. In exceptions, e.g. at eccentric mass or high requirements to accuracy, the value may be exceeded.

3.6 EPS System mini XZ

3.6.1 Dimensioned drawing EPS mini XZ

Type	A
PEL20-060	374 mm
PEL20-130	444 mm
PEL20-190	504 mm
PEL20-290	604 mm
PEL20-470	784 mm
PEL20-560	874 mm

Type	A
PEL20-080-SL	314 mm
PEL20-140-SL	374 mm
PEL20-210-SL	444 mm
PEL20-270-SL	504 mm
PEL20-370-SL	604 mm
PEL20-550-SL	784 mm
PEL20-640-SL	874 mm

Type	B
ES20-50-SL	191.5 mm
ES20-100-SL	285 mm
ES20-200	365 mm
ES20-300	495 mm

① MagSpring

② Path measuring system

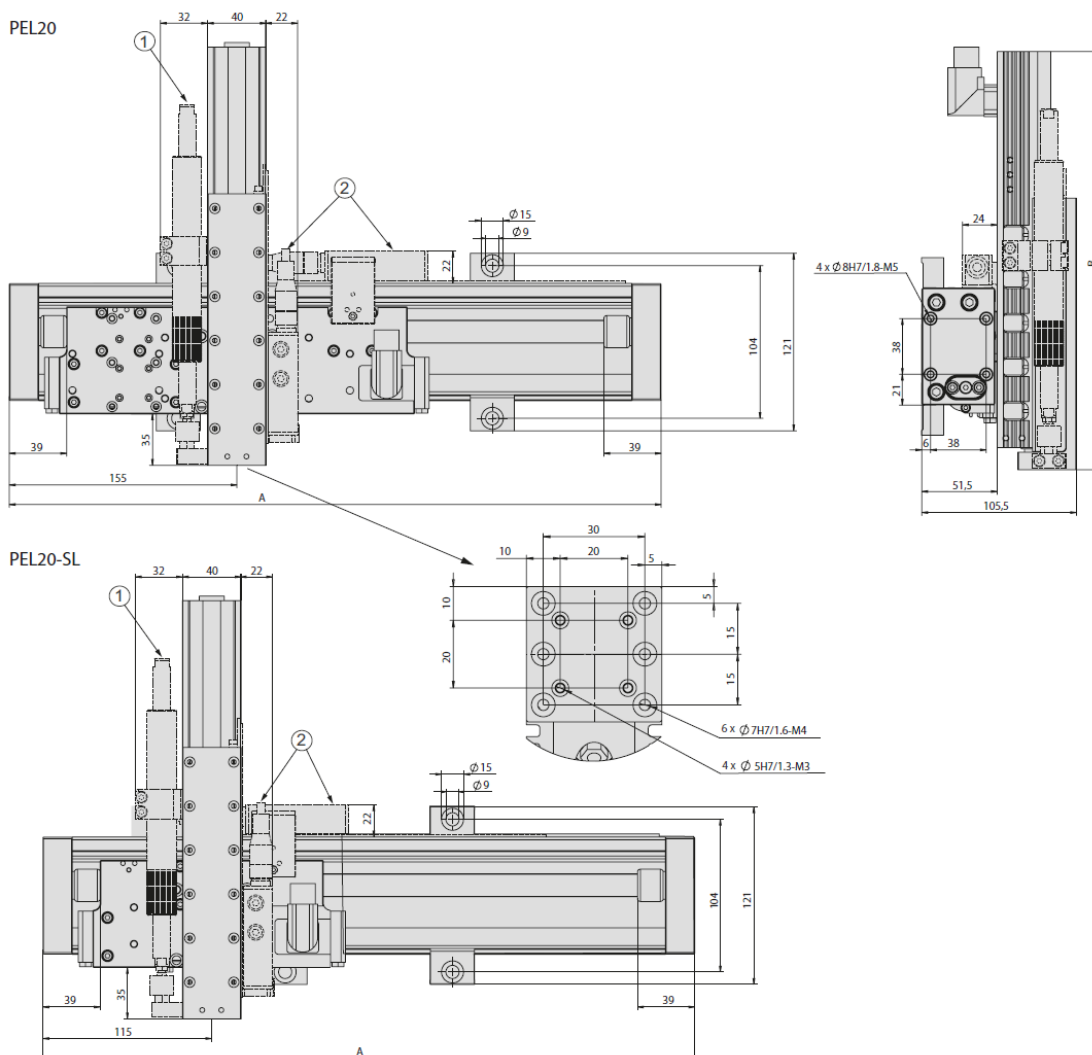

Fig. 6 Dimensioned drawing EPS mini XZ

3.6.2 Technical data EPS mini XZ

EPS mini XZ		
Order number	50444431	
Drive type	electrical, linear motor	
Repeat accuracy	± 0.05 mm	
- with external path measuring system (1 µm)	± 0.02 mm	
Temperature range	0 ... 50 °C	
Control block with 5/3, 5/2 or vacuum units	up to 6 valves	
Type	X-axis	
Axis	PEL20-SL	PEL20
Stroke horizontal	80, 140, 210, 270, 370, 550, 640 mm	60, 130, 190, 290, 470, 560 mm
Maximum speed	6.8 m/s	4.8 m/s
Peak force	67 N	137 N
Permanent force	15 N	31 N
Type	Z-axis	
Axis	ES20	ES20
Stroke vertical	50 mm	100, 200, 300 mm
Maximum speed	6.8 m/s	4.8 m/s
Peak force	67 N	137 N
Permanent force	15 N	31 N

Included in the delivery *

- 2x Ø 5h6 Centring sleeves
- 2x Ø 7h6 Centring sleeves
- 2x Ø 9h7 Centring sleeves
- MagSpring or compensation spring
- Hose or drag chain
- Motor cable
- Completely wired
- Controller parametrised

* Deviations possible depending on installed peripherals

Accessories

- (Catalogue HT accessories)
- Console
 - Valve block
- (Catalogue HT components linear)
- Path measuring system
- (Catalogue HT components gripping/rotating)
- Rotary module
 - Gripper module

3.6.3 Module loads EPS mini XZ

Type	ES20-SL	ES20
Dynamic torque Mx	5 Nm	5 Nm
Dynamic torque My	25 Nm	50 Nm
Dynamic torque Mz	25 Nm	50 Nm

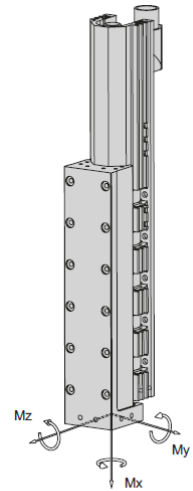

Payload (centric)	
Stroke X	up to 640 mm
Stroke Z	
50 mm	3 kg
100 mm	2 kg
200 mm	1 kg

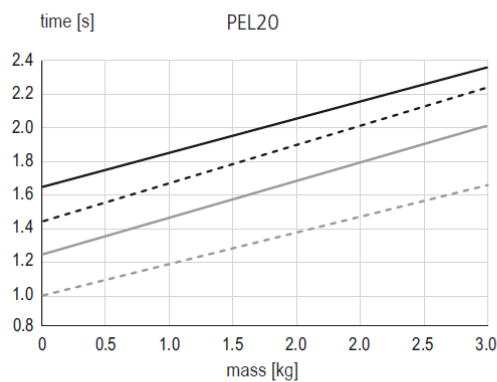
Cycle times EPS mini XZ for Pick & Place

stroke X/Z

500/ 100 ————

500/ 50 - - - - -

300/ 50 - · - · -

100/ 50 · · · · ·

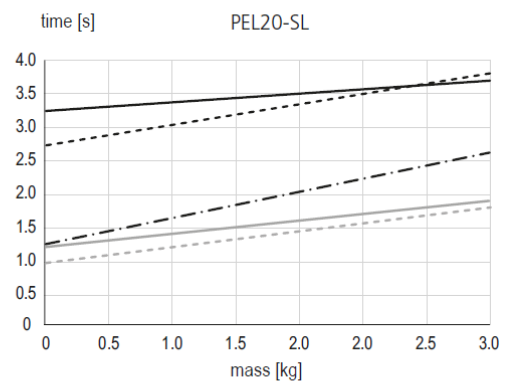

stroke X/Z

600/ 100 ————

600/ 50 - - - - -

300/ 500 - · - · -

100/ 100 · · · · ·

100/ 50 · · · · ·

Times including 2 x 100 ms gripping time

Comment:

The values in the chart correspond to a Pick & Place cycle (6 subsequent movements + 2 x 100 ms gripping time). The indicated mass is centrally installed at the vertical linear unit. Standstill times of handling permit shorter movement times. In exceptions, e.g. at eccentric mass or high requirements to accuracy, the value may be exceeded..

3.7 EPS System midi XZ

3.7.1 Dimensioned drawing EPS midi XZ

Type	A	C	L
PDL30-X-D19	40 mm	134 mm	X + 270 mm
PDL30-X-D20	50 mm	144 mm	X + 290 mm
PDL40-X-D27	49 mm	169 mm	X + 340 mm
PDL40-X-D28	64 mm	182 mm	X + 370 mm
PDL40-X-HP-D27	49 mm	229 mm	X + 460 mm
PDL40-X-HP-D28	64 mm	242 mm	X + 490 mm

Type	B
ES20-50-SL	191.5 mm
ES20-100-SL	285 mm
ES20-200	365 mm
ES20-300	495 mm

- ① MagSpring
- ② Path measuring system
- X Stroke of the X-axis

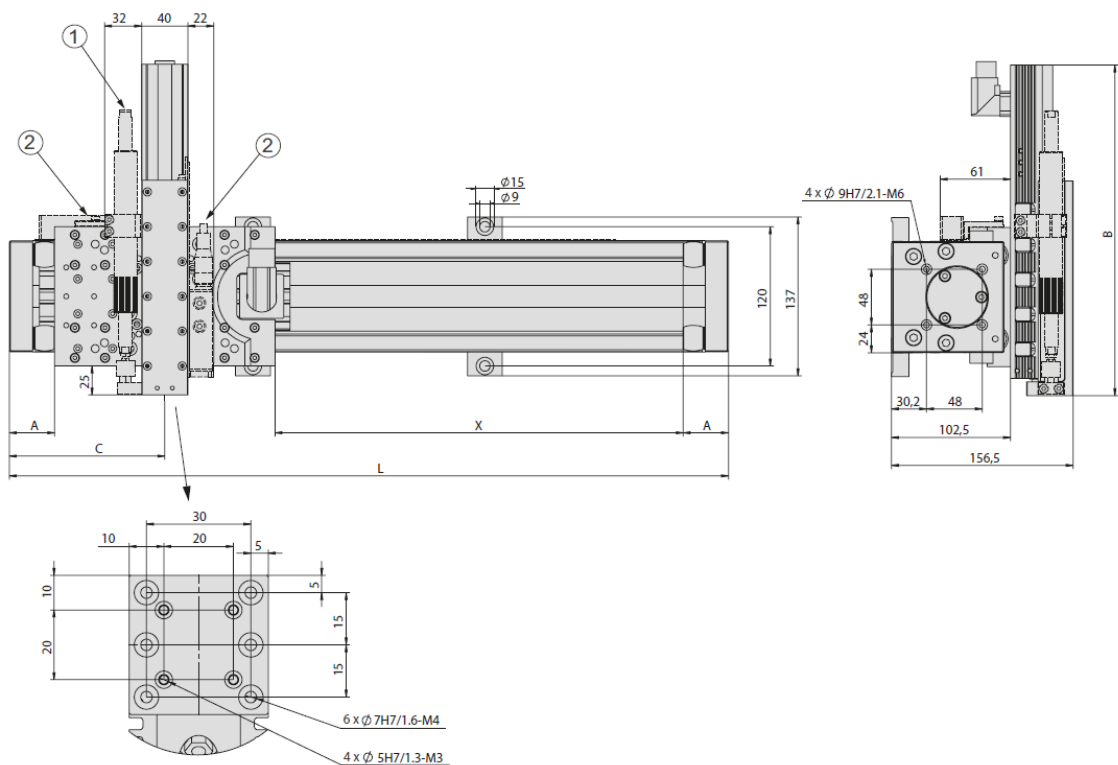
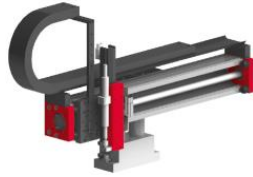

Fig. 7 Dimensioned drawing EPS midi XZ

3.7.2 Technical data EPS midi XZ

EPS midi XZ

Order number	50444432
Drive type	electrical, linear motor
Repeat accuracy	± 0.05 mm
- with external path measuring system (1 µm)	± 0.02 mm
Temperature range	0 ... 50 °C
Control block with 5/3, 5/2 or vacuum units	up to 6 valves

Type	X-axis		
Axis	PDL30	PDL40	PDL40-HP
Stroke horizontal	90, 130, 150, 230, 250, 330, 350, 430, 450, 530, 550, 630, 650, 730, 930, 1130, 1330 mm	170, 160, 170, 230, 280, 320, 370, 440, 460, 530, 580, 670, 880, 1060, 1270, 1480, 1660 mm	110, 160, 200, 250, 320, 340, 410, 460, 550, 760, 940, 1150, 1360, 1540 mm
Maximum speed	3.2 m/s	3 m/s	2 m/s
Peak force	255 N	550 N	1024 N
Permanent force	51 N	145 N	203 N

Type	Z-axis	
Axis	ES20	ES20
Stroke vertical	50 mm	100, 200, 300 mm
Maximum speed	6.8 m/s	4.8 m/s
Peak force	67 N	137 N
Permanent force	15 N	31 N

Included in the delivery *

- 2x Ø 5h6 Centring sleeves
- 2x Ø 7h6 Centring sleeves
- 2x Ø 9h7 Centring sleeves
- MagSpring or compensation spring
- Hose or drag chain
- Motor cable
- Completely wired
- Controller parametrised

Accessories

- (Catalogue HT accessories)
- Console
 - Valve block
- (Catalogue HT components linear)
- Path measuring system
- (Catalog HT components gripping/rotating)
- Rotary module
 - Gipper module

* Deviations possible depending on installed peripherals

3.7.3 Module loads EPS midi XZ

Type	ES20-SL	ES20
Dynamic torque Mx	5 Nm	5 Nm
Dynamic torque My	25 Nm	50 Nm
Dynamic torque Mz	25 Nm	50 Nm

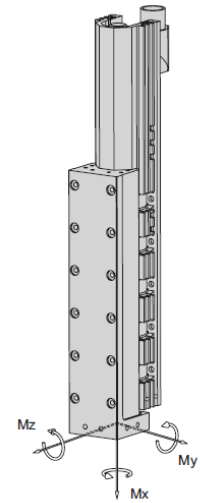

Payload (centric)	
Stroke X	up to 1660 mm
Stroke Z	
50 mm	3 kg
100 mm	2.5 kg
200 mm	2 kg
300 mm	1.5 kg

Cycle times EPS midi XZ for Pick & Place

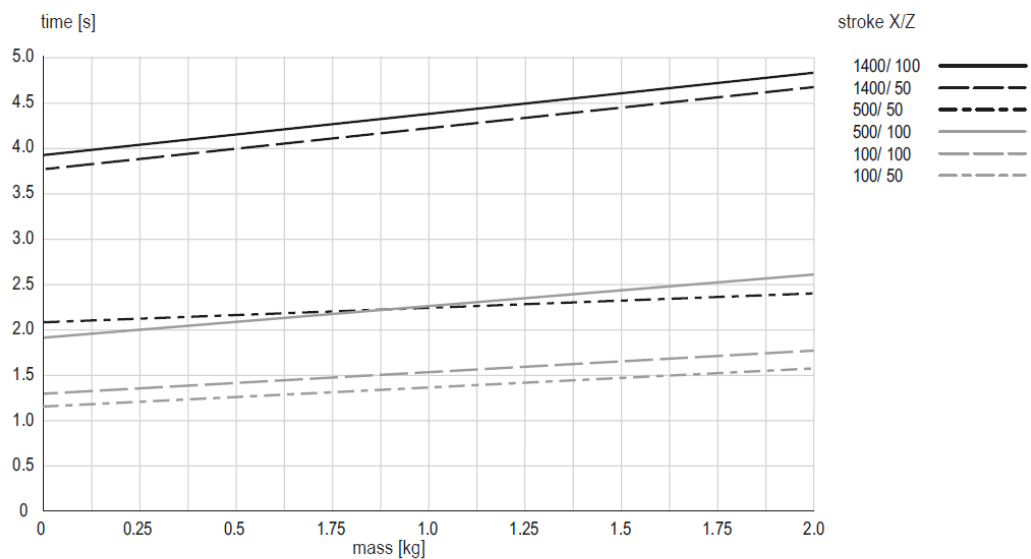

times including 2 x 100 ms gripping time

Comment:

The values in the chart correspond to a Pick & Place cycle (6 subsequent movements + 2 x 100 ms gripping time). The indicated mass is centrally installed at the vertical linear unit. Standstill times of handling permit shorter movement times. In exceptions, e.g. at eccentric mass or high requirements to accuracy, the value may be exceeded..

3.8 EPS System maxi XZ

3.8.1 Dimensioned drawing EPS maxi XZ

Type	A	C	L
PDL30-X-D19	40 mm	134 mm	X + 270 mm
PDL30-X-D20	50 mm	144 mm	X + 290 mm
PDL40-X-D27	49 mm	169 mm	X + 340 mm
PDL40-X-D28	64 mm	182 mm	X + 370 mm
PDL40-X-HP-D27	49 mm	229 mm	X + 460 mm
PDL40-X-HP-D28	64 mm	242 mm	X + 490 mm

Type	B
ES30-50-SL	288 mm
ES30-100-SL	328 mm
ES30-100	328 mm
ES30-200-SL	428 mm
ES30-200	428 mm
ES30-300	528 mm
ES30-400	628 mm
ES30-500	728 mm

- ① MagSpring
- ② Path measuring system
- X Stroke of the X-axis

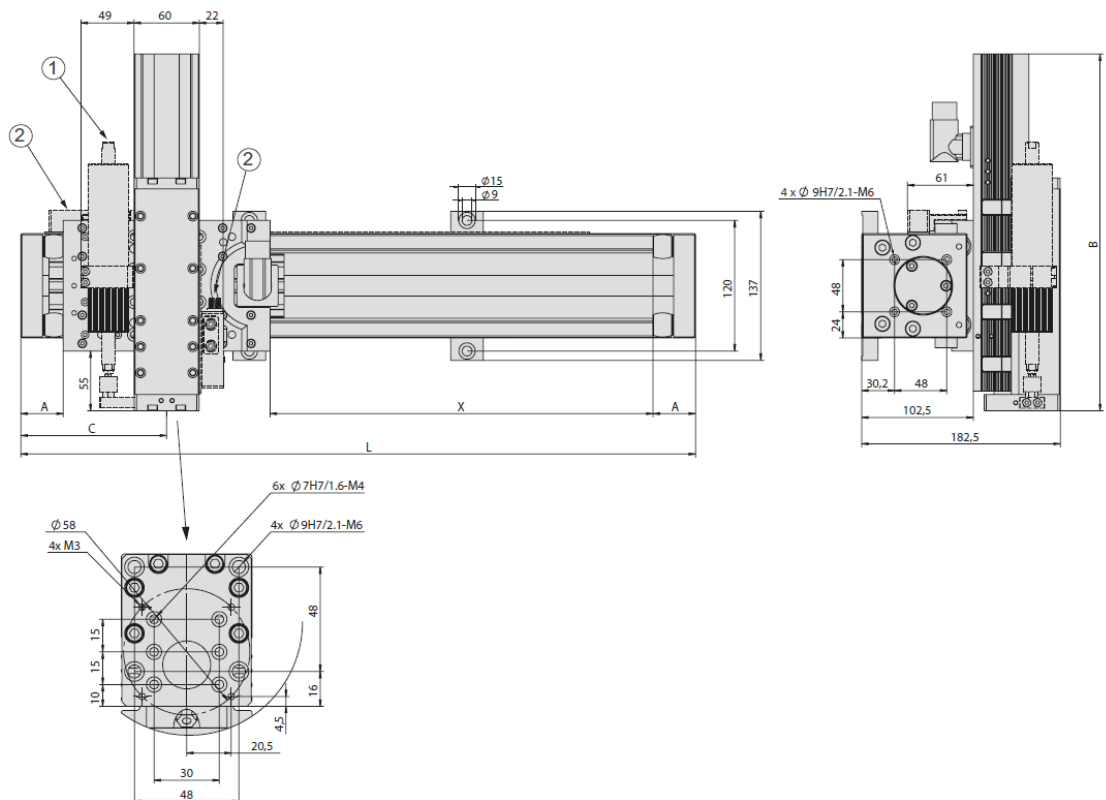

Fig. 8 Dimensioned drawing EPS maxi XZ

3.8.2 Technical data EPS maxi XZ

EPS maxi XZ

Order number	50444433
Drive type	electrical, linear motor
Repeat accuracy	± 0.05 mm
- with external path measuring system (1 µm)	± 0.02 mm
Temperature range	0 ... 50 °C
Control block with 5/3, 5/2 or vacuum units	up to 6 valves

Type	X-axis		
Axis	PDL30	PDL40	PDL40-HP
Stroke horizontal	90, 130, 150, 230, 250, 330, 350, 430, 450, 530, 550, 630, 650, 730, 930, 1130, 1330 mm	170, 160, 170, 230, 280, 320, 370, 440, 460, 530, 580, 670, 880, 1060, 1270, 1480, 1660 mm	110, 160, 200, 250, 320, 340, 410, 460, 550, 760, 940, 1150, 1360, 1540 mm
Maximum speed	3.2 m/s	3 m/s	2 m/s
Peak force	255 N	550 N	1024 N
Permanent force	51 N	145 N	203 N

Type	Z-axis
Axis	ES30
Stroke vertical	50, 100, 200, 300, 400, 500 mm
Maximum speed	3.2 m/s
Peak force	255 N
Permanent force	51 N

Included in the delivery *

- 2x Ø 7h6 Centring sleeves
- 4x Ø 9h7 Centring sleeves
- MagSpring
- Hose or drag chain
- Motor cable
- Completely wired
- Controller parametrised

Accessories

- (Catalogue HT accessories)
- Console
 - Valve block
- (Catalogue HT components linear)
- Path measuring system
- (Catalogue HT components gripping/rotating)
- Rotary modules
 - Gripper modules

* Deviations possible depending on installed peripherals

3.8.3 Module loads EPS maxi XZ

Type	ES30-SL	ES30
Dynamic torque Mx	30 Nm	30 Nm
Dynamic torque My	40 Nm	80 Nm
Dynamic torque Mz	40 Nm	80 Nm

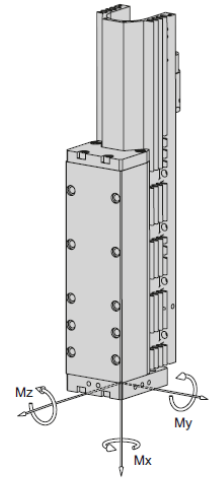

Payload (centric)	
Stroke X	up to 1660 mm
Stroke Z	
50 mm	8 kg
100 mm	7 kg
200 mm	6 kg
300 mm	5 kg
400 mm	4 kg
500 mm	3 kg

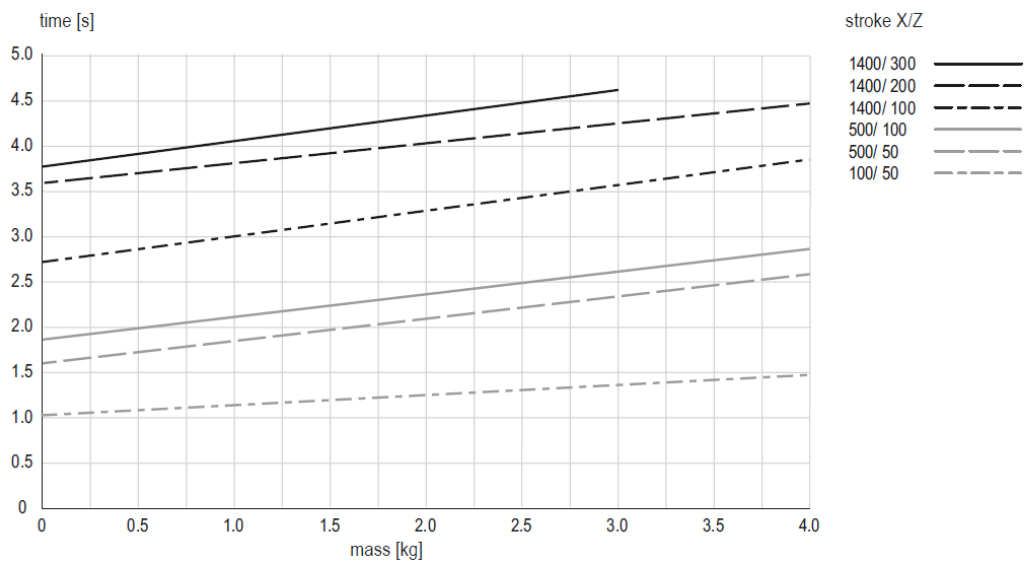
Cycle times EPS maxi XZ for Pick & Place

Times including 2 x 100 ms gripping time

Comment:

The values in the chart correspond to a Pick & Place cycle (6 subsequent movements + 2 x 100 ms gripping time). The indicated mass is centrally installed at the vertical linear unit. Standstill times of handling permit shorter movement times. In exceptions, e.g. at eccentric mass or high requirements to accuracy, the value may be exceeded.

3.9 EPS System mini XYZ

3.9.1 Dimensioned drawing EPS mini XYZ

Type	A
PEL20-060	374 mm
PEL20-130	444 mm
PEL20-190	504 mm
PEL20-290	604 mm
PEL20-470	784 mm
PEL20-560	874 mm

Type	A
PEL20-080-SL	314 mm
PEL20-140-SL	374 mm
PEL20-210-SL	444 mm
PEL20-270-SL	504 mm
PEL20-370-SL	604 mm
PEL20-550-SL	784 mm
PEL20-640-SL	874 mm

Type	B, C
ES20-50-SL	191.5 mm
ES20-100-SL	285 mm
ES20-200	365 mm
ES20-300	495 mm

- ① MagSpring
- ② Path measuring system
- ③ Auxiliary surface (not suitable for assembly)

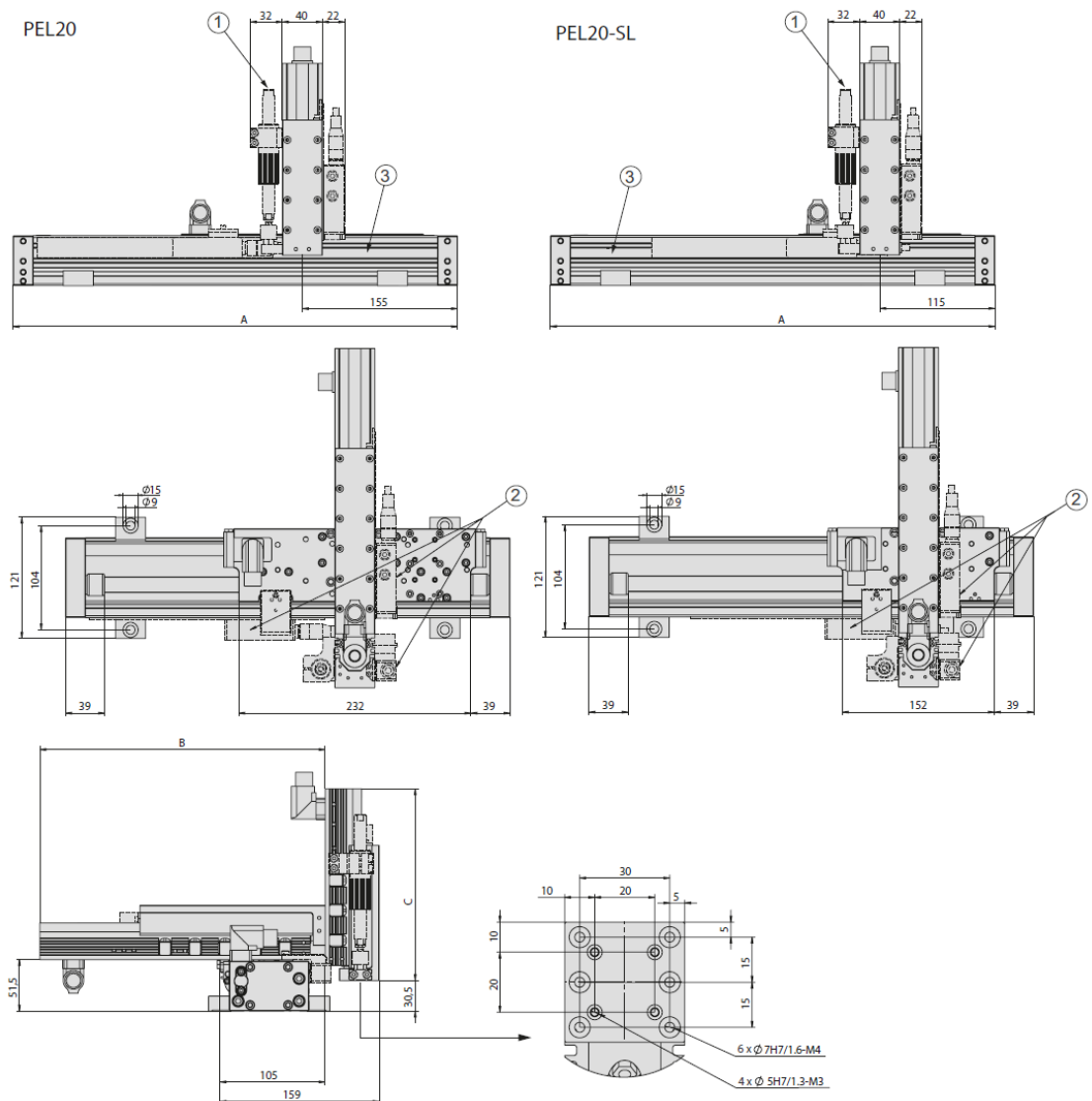

Fig. 9 Dimensioned drawing EPS mini XYZ

3.9.2 Technical data EPS mini XYZ

EPS mini XYZ
Order number **50444434**

Drive type	electrical, linear motor
Repeat accuracy	± 0.05 mm
- with external path measuring system (1 µm)	± 0.02 mm
Temperature range	0 ... 50 °C
Control block with 5/3, 5/2 or vacuum units	up to 6 valves

Type	X-axis	
Axis	PEL20-SL	PEL20
Stroke horizontal	80, 140, 210, 270, 370, 550, 640 mm	60, 130, 190, 290, 470, 560 mm
Maximum speed	6.8 m/s	4.8 m/s
Peak force	67 N	137 N
Permanent force	15 N	31 N

Type	Y-axis	
Axis	ES20	ES20
Stroke horizontal	50 mm	100, 200, 300 mm
Maximum speed	6.8 m/s	4.8 m/s
Peak force	67 N	137 N
Permanent force	15 N	31 N

Type	Z-axis	
Axis	ES20	ES20
Stroke vertical	50 mm	100, 200, 300 mm
Maximum speed	6.8 m/s	4.8 m/s
Peak force	67 N	137 N
Permanent force	15 N	31 N

Included in the delivery *

- 2x Ø 5h6 Centring sleeves
- 2x Ø 7h6 Centring sleeves
- 2x Ø 9h7 Centring sleeves
- MagSpring or compensation spring
- Hose or drag chain
- Motor cable
- Completely wired
- Controller parametrised

* Deviations possible depending on installed peripherals

Accessories

(Catalogue HT accessories)

- Console
- Valve block
- (Catalogue HT components linear)
- Path measuring system
- (Catalog HT components gripping/rotating)
- Rotary module
- Gripper module

3.9.3 Module loads EPS mini XYZ

Type	ES20-SL	ES20
Dynamic torque Mx	5 Nm	5 Nm
Dynamic torque My	25 Nm	50 Nm
Dynamic torque Mz	25 Nm	50 Nm

Payload (centric)				
Stroke Y	50 mm	100 mm	200 mm	
Stroke Z				
50 mm	3 kg	2 kg	1 kg	
100 mm	2 kg	1 kg	0.5 kg	
200 mm	1 kg	0.5 kg	-	

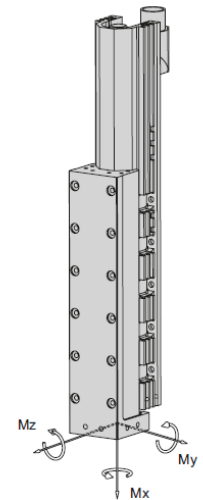

Cycle times EPS mini XYZ for Pick & Place

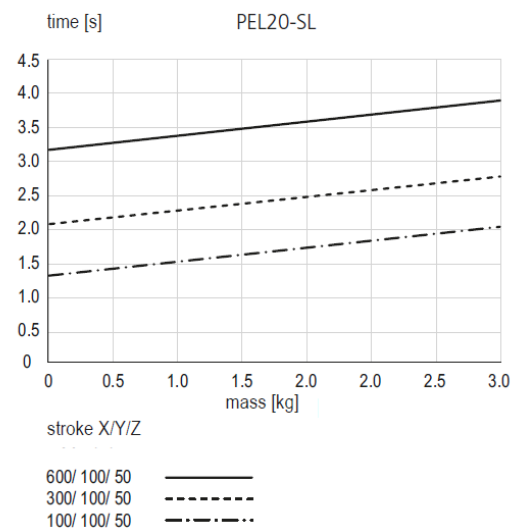
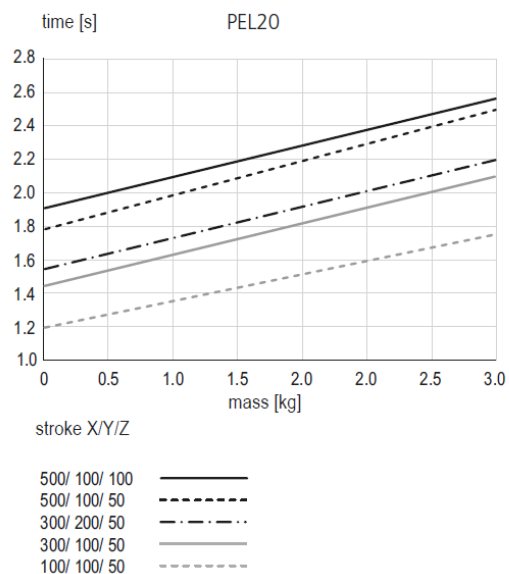

Times including 2 x 100 ms gripping time

Comment:

The values in the chart correspond to a Pick & Place cycle (6 subsequent movements + 2 x 100 ms gripping time). The indicated mass is centrally installed at the vertical linear unit. Standstill times of handling permit shorter movement times. In exceptions, e.g. at eccentric mass or high requirements to accuracy, the value may be exceeded.

3.10 EPS System midi XYZ

3.10.1 Dimensioned drawing EPS midi XYZ

Type	A	C	L
PDL30-X-D19	40 mm	134 mm	X + 270 mm
PDL30-X-D20	50 mm	144 mm	X + 290 mm
PDL40-X-D27	49 mm	169 mm	X + 340 mm
PDL40-X-D28	64 mm	182 mm	X + 370 mm
PDL40-X-HP-D27	49 mm	229 mm	X + 460 mm
PDL40-X-HP-D28	64 mm	242 mm	X + 490 mm

Type	B	C
ES30-50-SL	288 mm	
ES30-100-SL	328 mm	
ES30-100	328 mm	
ES30-200-SL	428 mm	
ES30-200	428 mm	
ES30-300	528 mm	
ES30-400	628 mm	
ES30-500	728 mm	
ES20-50-SL		191.5 mm
ES20-100-SL		285 mm
ES20-200		365 mm
ES20-300		495 mm

- ① MagSpring
- ② Path measurement system
- X Stroke of the X-axis

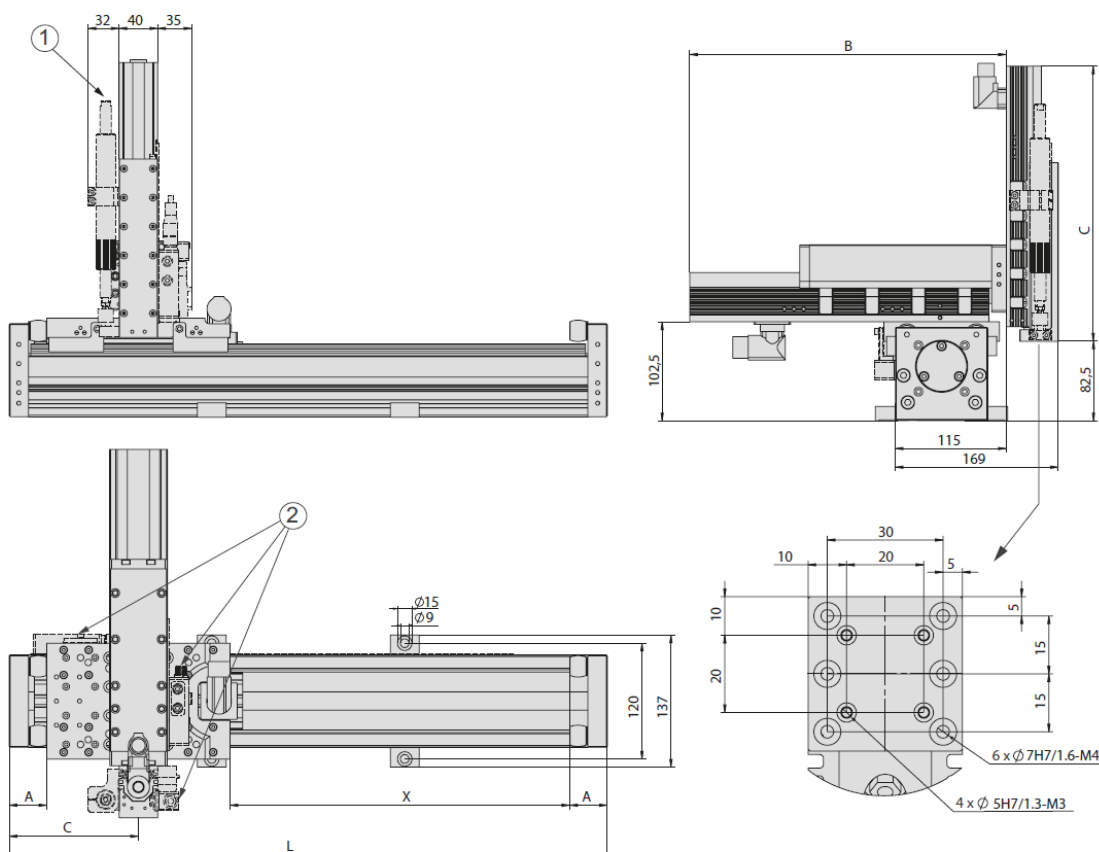

Fig. 10 Dimensioned drawing EPS midi XYZ

3.10.2 Technical data EPS midi XYZ

EPS midi XYZ
Order number **50444435**

Drive type	electrical, linear motor
Repeat accuracy	± 0.05 mm
- with external path measurement (1 µm)	± 0.02 mm
Temperature range	0 ... 50 °C
Control block with 5/3, 5/2 or vacuum units	up to 6 valves

Type	X-axis		
Axis	PDL30	PDL40	PDL40-HP
Stroke horizontal	90, 130, 150, 230, 250, 330, 350, 430, 450, 530, 550, 630, 650, 730, 930, 1130, 1330 mm	70, 160, 170, 230, 280, 320, 370, 440, 460, 530, 580, 670, 880, 1060, 1270, 1480, 1660 mm	110, 160, 200, 250, 320, 340, 410, 460, 550, 760, 940, 1150, 1360, 540 mm
Maximum speed	3.2 m/s	3 m/s	2 m/s
Peak force	255 N	550 N	1024 N
Permanent force	51 N	145 N	203 N

Type	Y-axis
Axis	ES30
Stroke horizontal	50, 100, 200, 300, 400, 500 mm
Maximum speed	3.2 m/s
Peak force	255 N
Permanent force	51 N

Type	Z-axis	
Axis	ES20	ES20
Stroke vertical	50 mm	100, 200, 300 mm
Maximum speed	6.8 m/s	4.8 m/s
Peak force	67 N	137 N
Permanent force	15 N	31 N

Included in the delivery *

- 2x Ø 5h6 Centring sleeves
- 2x Ø 7h6 Centring sleeves
- 2x Ø 9h7 Centring sleeves
- MagSpring or compensation spring
- Hose or drag chain
- Motor cable
- Completely wired
- Controller parametrised

Accessories

- (Catalogue HT accessories)
- Console
 - Valve block
- (Catalogue HT components linear)
- Path measuring system
- (Catalogue HT components gripping/rotating)
- Rotary module
 - Gripper module

* Deviations possible depending on installed peripherals

3.10.3 Module loads EPS midi XYZ

Type	ES20-SL	ES20
Dynamic torque Mx	5 Nm	5 Nm
Dynamic torque My	25 Nm	50 Nm
Dynamic torque Mz	25 Nm	50 Nm

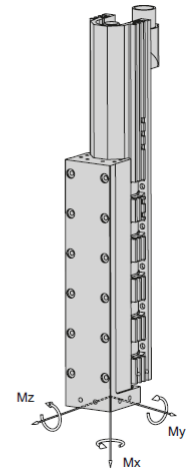

Payload (centric)							
Stroke Y	50 mm	100 mm	200 mm	300 mm	400 mm	500 mm	
Stroke Z							
50 mm	4 kg	3 kg	2 kg	1 kg	0.5 kg	0.5 kg	
100 mm	3 kg	2 kg	1 kg	0.5 kg	-	-	
200 mm	2 kg	1 kg	0.5 kg	-	-	-	
300 mm	1 kg	0.5 kg	-	-	-	-	

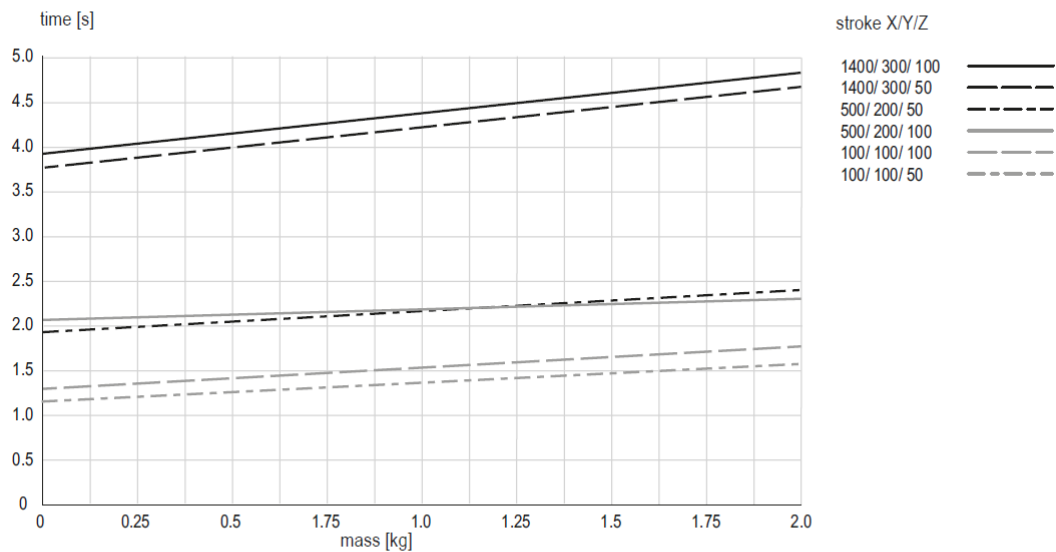
Cycle times EPS midi XYZ for Pick & Place

Times including 2 x 100 ms gripping time

Comment:

The values in the chart correspond to a Pick & Place cycle (6 subsequent movements + 2 x 100 ms gripping time). The indicated mass is centrally installed at the vertical linear unit. Standstill times of handling permit shorter movement times. In exceptions, e.g. at eccentric mass or high requirements to accuracy, the value may be exceeded.

3.11 EPS System maxi XYZ

3.11.1 Dimensioned drawing EPS maxi XYZ

Type	A	C	L
PDL30-X-D19	40 mm	134 mm	X + 270 mm
PDL30-X-D20	50 mm	144 mm	X + 290 mm
PDL40-X-D27	49 mm	169 mm	X + 340 mm
PDL40-X-D28	64 mm	182 mm	X + 370 mm
PDL40-X-HP-D27	49 mm	229 mm	X + 460 mm
PDL40-X-HP-D28	64 mm	242 mm	X + 490 mm

Type	B
ES30-50-SL	288 mm
ES30-100-SL	328 mm
ES30-100	328 mm
ES30-200-SL	428 mm
ES30-200	428 mm
ES30-300	528 mm
ES30-400	628 mm
ES30-500	728 mm

- ① MagSpring
- ② Path measuring system
- X Stroke of the X-axis

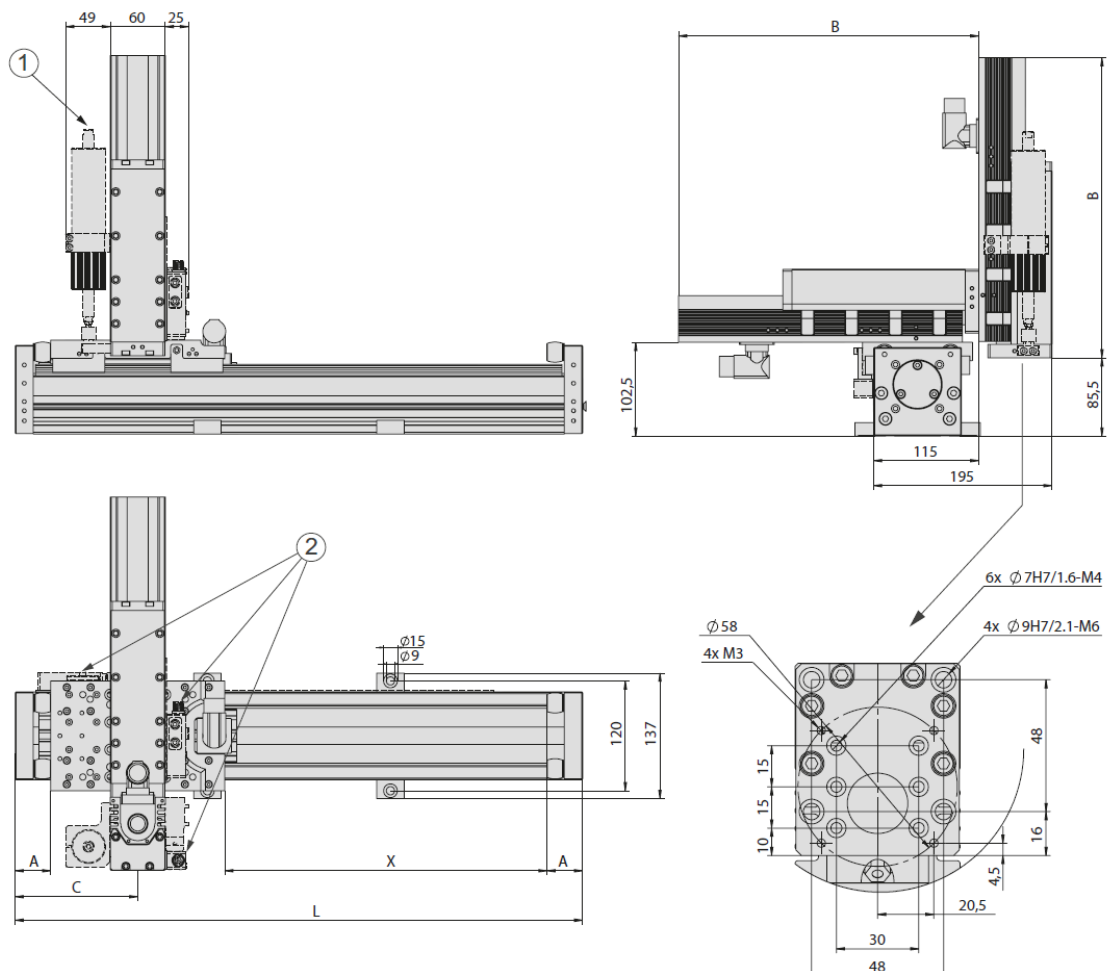

Fig. 11 Dimensioned drawing EPS maxi XYZ

3.11.2 Technical data EPS maxi XYZ

EPS maxi XYZ

Order number	50444436
Drive type	electrical, linear motor
Repeat accuracy	± 0.05 mm
- with external path measuring system (1 µm)	± 0.02 mm
Temperature range	0 ... 50 °C
Control block with 5/3, 5/2 or vacuum units	up to 6 valves

Type	X-axis		
Axis	PDL30	PDL40	PDL40-HP
Stroke horizontal	90, 130, 150, 230, 250, 330, 350, 430, 450, 530, 550, 630, 650, 730, 930, 1130, 1330 mm	70, 160, 170, 230, 280, 320, 370, 440, 460, 530, 580, 670, 880, 1060, 1270, 1480, 1660 mm	110, 160, 200, 250, 320, 340, 410, 460, 550, 760, 940, 1150, 1360, 1540 mm
Maximum speed	3.2 m/s	3 m/s	2 m/s
Peak force	255 N	550 N	1024 N
Permanent force	51 N	145 N	203 N

Type	Y-axis
Axis	ES30
Stroke horizontal	50, 100, 200, 300, 400, 500 mm
Maximum speed	3.2 m/s
Peak force	255 N
Permanent force	51 N

Type	Z-axis
Axis	ES30
Stroke vertical	50, 100, 200, 300, 400, 500 mm
Maximum speed	3.2 m/s
Peak force	255 N
Permanent force	51 N

Included in the delivery *

- 2x Ø 7h6 Centring sleeves
- 4x Ø 9h7 Centring sleeves
- MagSpring
- Hose or drag chain
- Motor cable
- Completely wired
- Controller parametrised

Accessories

- (Catalogue HT accessories)
- Console
 - Valve block
- (Catalogue HT components linear)
- Path measuring system
- (Catalogue HT components gripping/rotating)
- Rotary modules
 - Gripper modules

* Deviations possible depending on installed peripherals

3.11.3 Module loads EPS maxi XYZ

Type	ES30-SL	ES30
Dynamic torque Mx	30 Nm	30 Nm
Dynamic torque My	40 Nm	80 Nm
Dynamic torque Mz	40 Nm	80 Nm

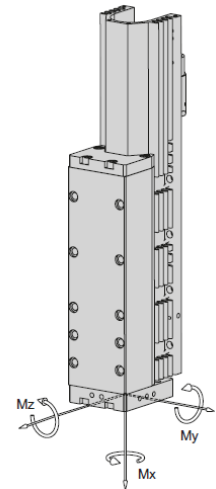

Payload (centric)						
Stroke horizontal (Y)	50 mm	100 mm	200 mm	300 mm	400 mm	500 mm
Stroke vertical (Z)						
50 mm	5 kg	4 kg	3 kg	2 kg	1 kg	0.5 kg
100 mm	4 kg	3 kg	2 kg	1 kg	0.5 kg	-
200 mm	3 kg	2 kg	1 kg	0.5 kg	-	-
300 mm	2 kg	1 kg	0.5 kg	-	-	-
400 mm	1 kg	0.5 kg	-	-	-	-
500 mm	0.5 kg	-	-	-	-	-

Cycle times EPS maxi XYZ for Pick & Place

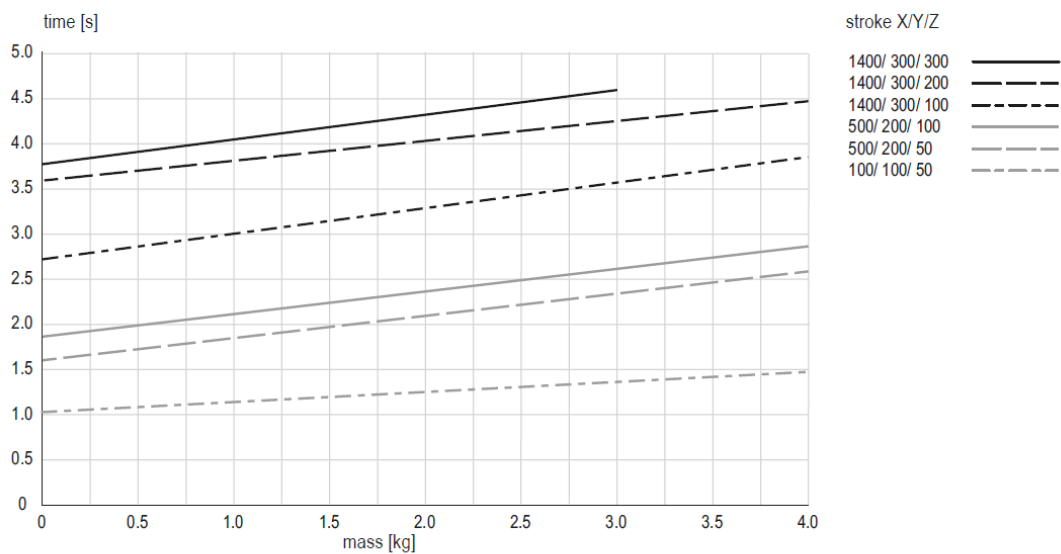

Times including 2 x 100 ms gripping time

Comment:

The values in the chart correspond to a Pick & Place cycle (6 subsequent movements + 2 x 100 ms gripping time). The indicated mass is centrally installed at the vertical linear unit. Standstill times of handling permit shorter movement times. In exceptions, e.g. at eccentric mass or high requirements to accuracy, the value may be exceeded.

3.12 EPS mini gantry XXYZ

3.12.1 Dimensioned drawing EPS mini gantry XXYZ

Type	A	B	E	G
PEL20-X-SL	X + 234 mm	A + 61 mm	114 mm	
PEL20-X	X + 314 mm	A + 61 mm	155 mm	
ES20-50-SL				192 mm
ES20-100-SL				285 mm
ES20-200				365 mm
ES20-300				495 mm

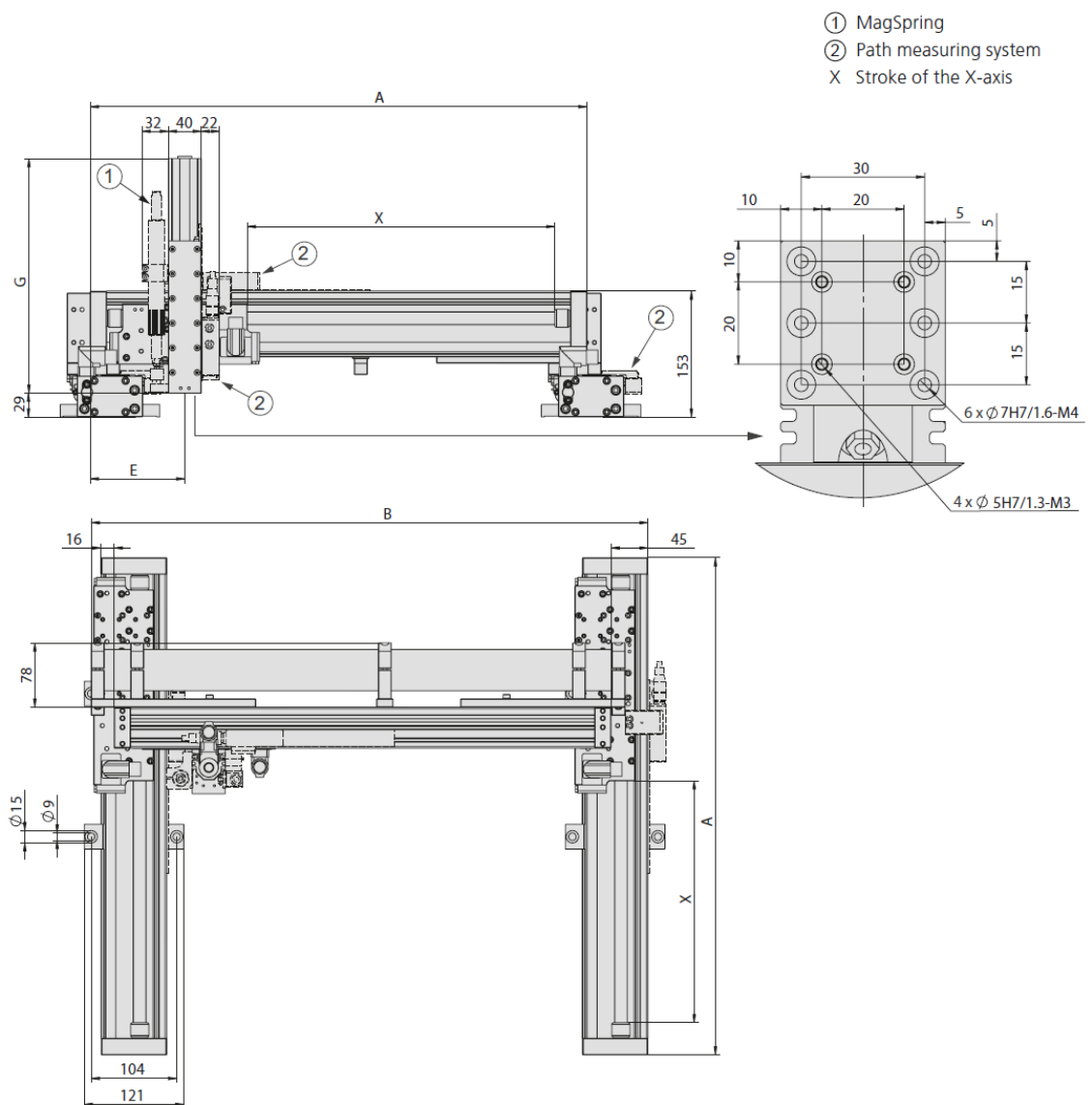

Fig. 12 Dimensioned drawing EPS mini gantry XXYZ

3.12.2 Technical data EPS mini gantry XXYZ

EPS mini gantry XXYZ
Order number **50444425**

Drive type	electrical, linear motor
Repeat accuracy	± 0.05 mm
- with external path measuring system (1 µm)	± 0.02 mm
Temperature range	0 ... 50 °C
Control block with 5/3, 5/2 or vacuum units	up to 6 valves

Type	X-axis
Axis	PEL20
Stroke horizontal	60, 130, 190, 290, 470, 560 mm
Maximum speed	4.8 m/s
Peak force	137 N
Permanent force	31 N

Type	Y-axis	
Axis	PEL20-SL	PEL20
Stroke horizontal	80, 140, 210, 270, 550, 640 mm	60, 130, 190, 290, 470, 560 mm
Maximum speed	6.8 m/s	4.8 m/s
Peak force	67 N	137 N
Permanent force	15 N	31 N

Type	Z-axis	
Axis	ES20	ES20
Stroke vertical	50 mm	100, 200, 300 mm
Maximum speed	6.8 m/s	4.8 m/s
Peak force	67 N	137 N
Permanent force	15 N	31 N

Included in the delivery *

- 2x Ø 5h6 Centring sleeves
- 2x Ø 7h6 Centring sleeves
- MagSpring or compensation spring
- Hose or drag chain
- Motor cable
- Completely wired
- Controller parametrised
- Gantry bracing
- Attachment blocs

* Deviations possible depending on installed peripherals

Accessories

- (Catalogue HT accessories)
- Valve block
- (Catalogue HT components linear)
- Path measuring system
- (Catalog HT components gripping/rotating)
- Rotary module
 - Gripper module

3.12.3 Module loads EPS mini gantry XXYZ

Type	ES20-SL	ES20
Dynamic torque Mx	5 Nm	5 Nm
Dynamic torque My	25 Nm	50 Nm
Dynamic torque Mz	25 Nm	50 Nm

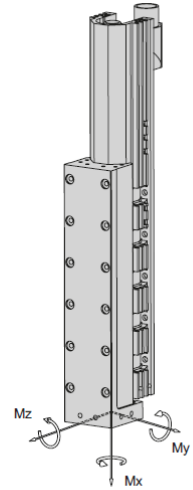

Payload (centric)			
Stroke Y	60 - 270 mm	290 - 370 mm	470 - 640 mm
Stroke Z			
50 mm	4 kg	4 kg	3 kg
100 mm	4 kg	3 kg	2 kg
200 mm	3 kg	2 kg	1 kg

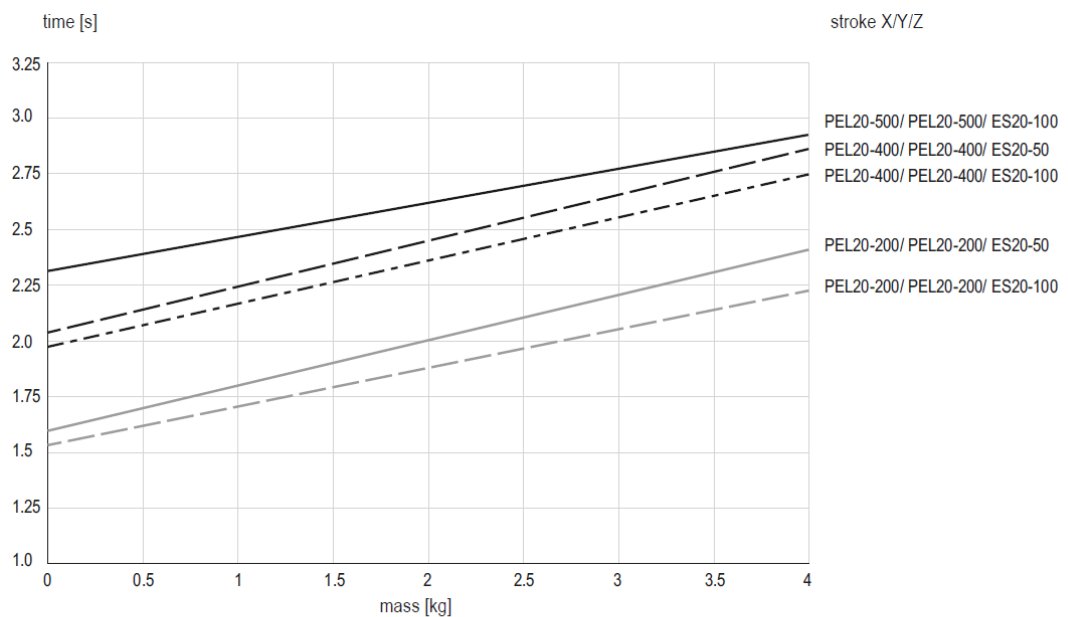
Cycle times EPS mini gantry XXYZ for Pick & Place

Times including 2 x 100 ms gripping time

Comment:

The values in the chart correspond to a Pick-and-Place cycle (6 subsequent movements + 2 x 100 ms gripping time). The indicated mass is centrally installed at the vertical linear unit. Standstill times of handling permit shorter movement times. In exceptions, e.g. at eccentric mass or high requirements to accuracy, the value may be exceeded.

3.13 EPS midi gantry XXYZ

3.13.1 Dimensioned drawing EPS midi gantry XXYZ

Type	B	C	D	E	F
PDL30-Y-D19	Y + 270 mm	134 mm	40 mm	134 mm	B + 150 mm
PDL30-Y-D20	Y + 290 mm	144 mm	50 mm	144 mm	B + 150 mm
PDL40-Y-D27	Y + 340 mm	143 mm	49 mm	169 mm	B + 150 mm
PDL40-Y-D28	Y + 370 mm	158 mm	64 mm	182 mm	B + 150 mm
PDL40-Y-HP-D27	Y + 460 mm	202 mm	49 mm	230 mm	B + 150 mm
PDL40-Y-HP-D28	Y + 490 mm	215 mm	64 mm	242 mm	B + 150 mm

Type	A	D
PEL30-X-D19-L/R	40 mm	X + 270 mm
PEL30-X-D20-L/R	50 mm	X + 290 mm
PEL40-X-D27-L/R	49 mm	X + 340 mm
PEL40-X-D28-L/R	64 mm	X + 370 mm
PEL40-X-HP-D27-L/R	49 mm	X + 460 mm
PEL40-X-HP-D28-L/R	64 mm	X + 490 mm

Type	G
ES20-50-SL	192 mm
ES20-100-SL	285 mm
ES20-200	365 mm
ES20-300	490 mm

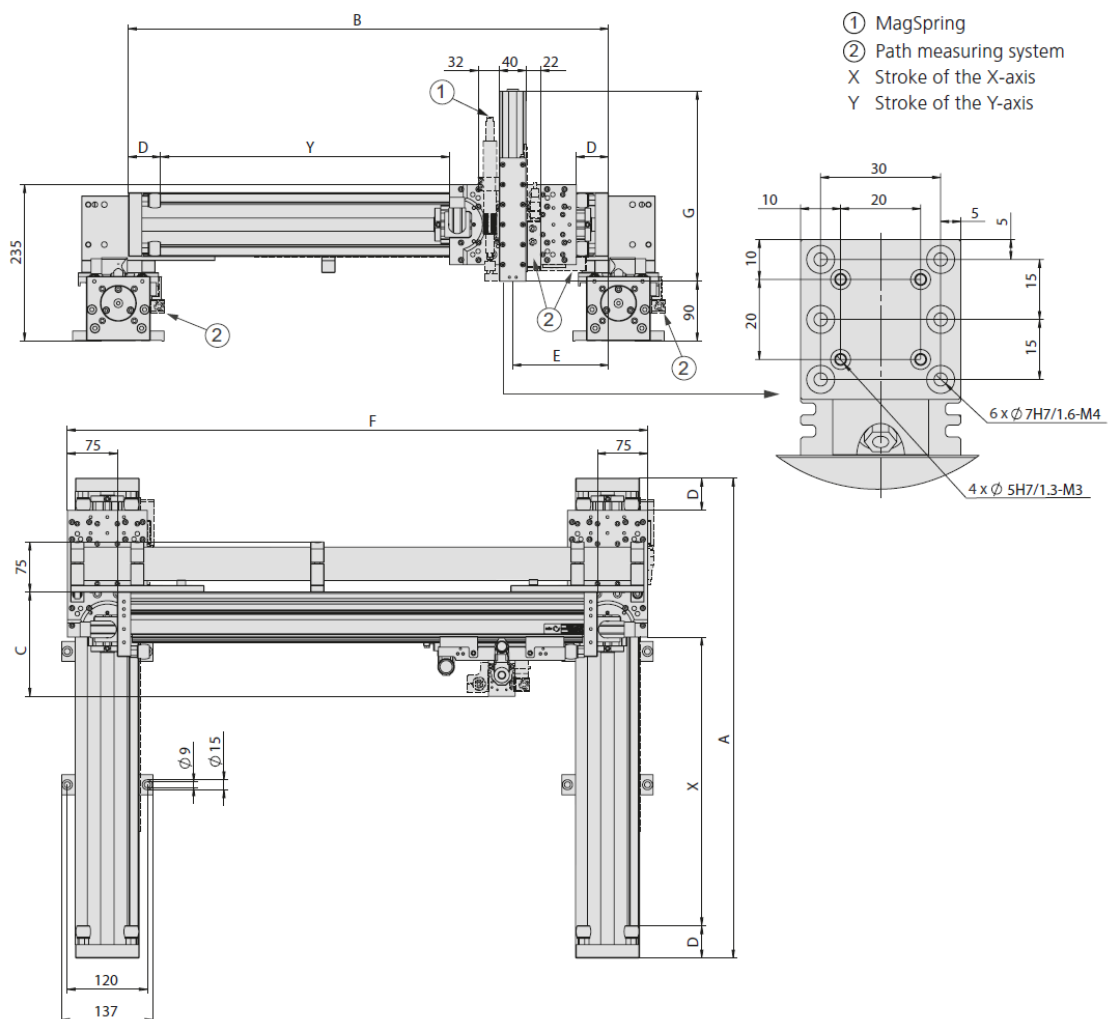

Fig. 13 Dimensioned drawing EPS midi gantry XXYZ

3.13.2 Technical data EPS midi gantry XXYZ

EPS midi gantry XXYZ
Order number **50444426**

Drive type	electrical, linear motor
Repeat accuracy	± 0.05 mm
- with external path measuring system (1 µm)	± 0.02 mm
Temperature range	0 ... 50 °C
Control block with 5/3, 5/2 or vacuum units	up to 6 valves

Type	X-axis		
Axis	PEL30	PEL40	PEL40-HP
Stroke horizontal	90, 130, 150, 230, 250, 330, 350, 430, 450, 530, 550, 630, 650, 730, 930, 1130, 1330 mm	70, 160, 170, 230, 280, 320, 370, 440, 460, 530, 580, 670, 880, 1060, 1270, 1480, 1660 mm	110, 160, 200, 250, 320, 340, 410, 460, 550, 760, 940, 1150, 1360, 1540 mm
Maximum speed	3.2 m/s	3 m/s	2 m/s
Peak force	255 N	550 N	1024 N
Permanent force	51 N	145 N	203 N

Type	Y-axis		
Axis	PDL30	PDL40	PDL40-HP
Stroke horizontal	90, 130, 150, 230, 250, 330, 350, 430, 450, 530, 550, 630, 650, 730, 930, 1130, 1330 mm	70, 160, 170, 230, 280, 320, 370, 440, 460, 530, 580, 670, 880, 1060, 1270, 1480, 1660 mm	110, 160, 200, 250, 320, 340, 410, 460, 550, 760, 940, 1150, 1360, 1540 mm
Maximum speed	3.2 m/s	3 m/s	2 m/s
Peak force	255 N	550 N	1024 N
Permanent force	51 N	145 N	203 N

Type	Z-axis	
Axis	ES20	ES20
Stroke vertical	50 mm	100, 200, 300 mm
Maximum speed	6.8 m/s	4.8 m/s
Peak force	67 N	137 N
Permanent force	15 N	31 N

Included in the delivery *

- 2x Ø 5h6 Centring sleeves
- 2x Ø 7h6 Centring sleeves
- MagSpring or compensation spring
- Hose or drag chain
- Motor cable
- Completely wired
- Controller parametrised
- Gantry bracing
- Attachment blocs

* Deviations possible depending on installed peripherals

Accessories

- (Catalogue HT accessories)
- Valve block
- (Catalogue HT components linear)
- Path measuring system
- (Catalog HT components gripping/rotating)
- Rotary module
 - Gripper module

3.13.3 Module loads EPS midi gantry XXYZ

Type	ES20-SL	ES20
Dynamic torque Mx	5 Nm	5 Nm
Dynamic torque My	25 Nm	50 Nm
Dynamic torque Mz	25 Nm	50 Nm

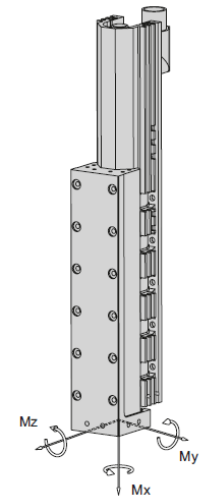

Payload (centric)	
Stroke Y	up to 1660 mm
Stroke Z	
50 mm	4 kg
100 mm	4 kg
200 mm	3 kg
300 mm	2 kg

Cycle times EPS midi gantry XXYZ for Pick & Place

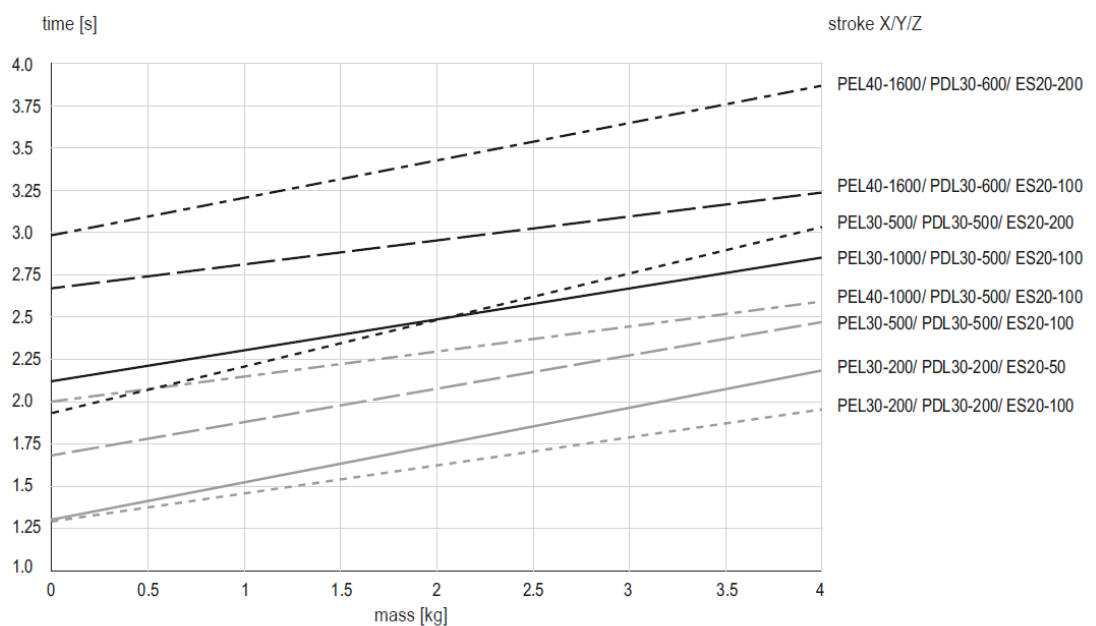

Times including 2 x 100 ms gripping time

Comment:

The values in the chart correspond to a Pick-and-Place cycle (6 subsequent movements + 2 x 100 ms gripping time). The indicated mass is centrally installed at the vertical linear unit. Standstill times of handling permit shorter movement times. In exceptions, e.g. at eccentric mass or high requirements to accuracy, the value may be exceeded.

3.14.2 Technical data EPS maxi XYZ

EPS maxi gantry XXYZ
Order number **50444426**

Drive type	electrical, linear motor
Repeat accuracy	± 0.05 mm
- with external path measuring system (1 µm)	± 0.02 mm
Temperature range	0 ... 50 °C
Control block with 5/3, 5/2 or vacuum units	up to 6 valves

Type	X-axis		
Axis	PEL30	PEL40	PEL40-HP
Stroke horizontal	90, 130, 150, 230, 250, 330, 350, 430, 450, 530, 550, 630, 650, 730, 930, 1130, 1330 mm	70, 160, 170, 230, 280, 320, 370, 440, 460, 530, 580, 670, 880, 1060, 1270, 1480, 1660 mm	110, 160, 200, 250, 320, 340, 410, 460, 550, 760, 940, 1150, 1360, 1540 mm
Maximum speed	3.2 m/s	3 m/s	2 m/s
Peak force	255 N	550 N	1024 N
Permanent force	51 N	145 N	203 N

Type	Y-axis		
Axis	PDL30	PDL40	PDL40-HP
Stroke horizontal	90, 130, 150, 230, 250, 330, 350, 430, 450, 530, 550, 630, 650, 730, 930, 1130, 1330 mm	70, 160, 170, 230, 280, 320, 370, 440, 460, 530, 580, 670, 880, 1060, 1270, 1480, 1660 mm	110, 160, 200, 250, 320, 340, 410, 460, 550, 760, 940, 1150, 1360, 1540 mm
Maximum speed	3.2 m/s	3 m/s	2 m/s
Peak force	255 N	550 N	1024 N
Permanent force	51 N	145 N	203 N

Type	Z-axis
Axis	ES30
Stroke vertical	50, 100, 200, 300, 400, 500 mm
Maximum speed	3.2 m/s
Peak force	255 N
Permanent force	51 N

Included in the delivery *

- 2x Ø 7h6 Centring sleeves
- 2x Ø 9h7 Centring sleeves
- MagSpring
- Hose or drag chain
- Motor cable
- Completely wired
- Controller parametrised
- Gantry bracing
- Attachment blocs

* Deviations possible depending on installed peripherals

Accessories

- (Catalogue HT accessories)
- Valve block
 - Clamping element
- (Catalogue HT components linear)
- Path measuring system
- (Catalog HT components gripping/rotating)
- Rotary module
 - Gripper module

3.14.3 Module loads EPS maxi gantry XXYZ

Type	ES30-SL	ES30
Dynamic torque Mx	30 Nm	30 Nm
Dynamic torque My	40 Nm	80 Nm
Dynamic torque Mz	40 Nm	80 Nm

Payload (centric)	
Stroke Y	up to 1660 mm
Stroke Z	
50 mm	8 kg
100 mm	7 kg
200 mm	5 kg
300 mm	4 kg
400 mm	3 kg
500 mm	2 kg

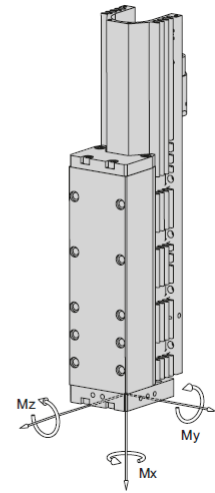
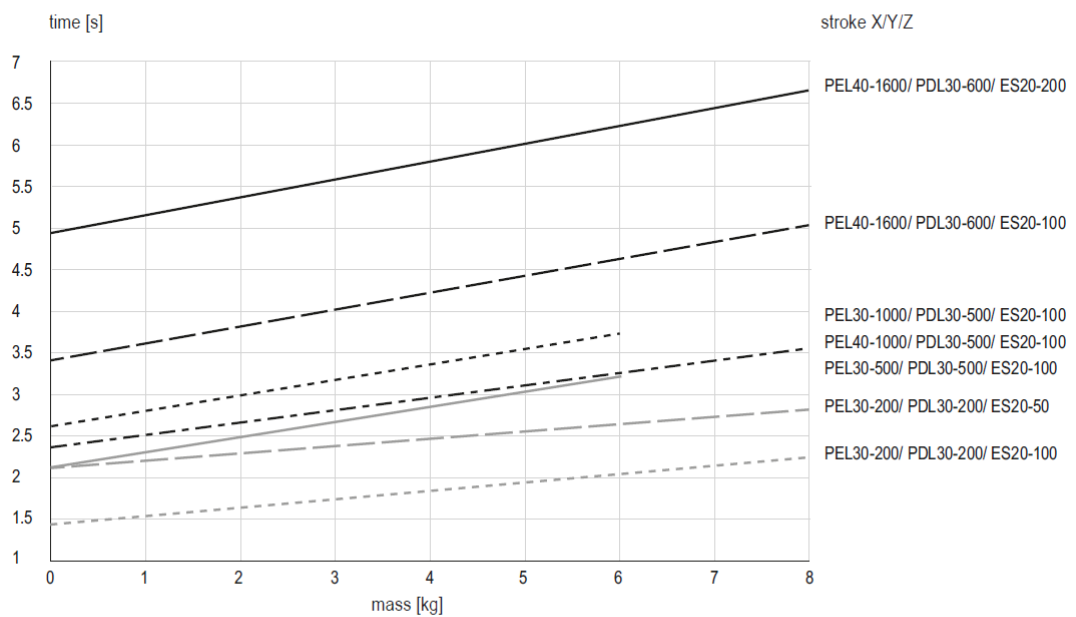
Cycle times EPS maxi gantry XXYZ for Pick & Place

Times including 2 x 100 ms gripping time

Comment:

The values in the chart correspond to a Pick-and-Place cycle (6 subsequent movements + 2 x 100 ms gripping time). The indicated mass is centrally installed at the vertical linear unit. Standstill times of handling permit shorter movement times. In exceptions, e.g. at eccentric mass or high requirements to accuracy, the value may be exceeded.

3.15 EPS mini gantry s

3.15.1 Dimensioned drawing EPS mini gantry s

Type	A	B	C	D	E	F	G
PDL30-X-D19	X + 270 mm		109 mm	40 mm			
PDL30-X-D20	X + 290 mm		119 mm	50 mm			
PDL40-X-D27	X + 340 mm		144 mm	49 mm			
PDL40-X-D28	X + 370 mm		159 mm	64 mm			
PDL40-X-HP-D27	X + 460 mm		204 mm	49 mm			
PDL40-X-HP-D28	X + 490 mm		219 mm	64 mm			
PEL20-Y-SL		Y + 234 mm			114 mm	B + 56 mm	
PEL20-Y		Y + 314 mm			155 mm	B + 56 mm	
ES20-50-SL							192 mm
ES20-100-SL							285 mm
ES20-200							365 mm
ES20-300							495 mm

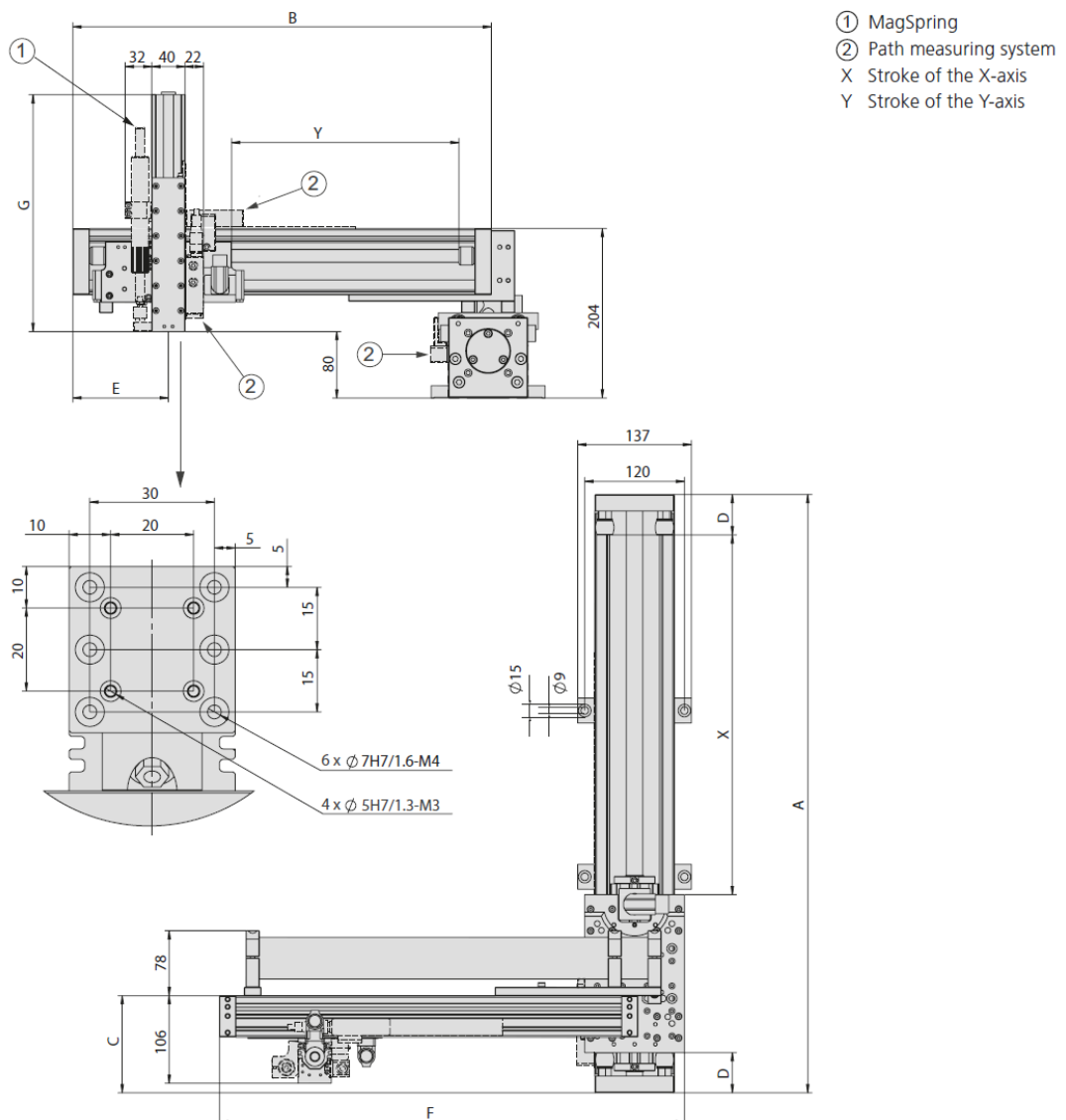

Fig. 15 Dimensioned drawing EPS mini gantry s

3.15.2 Technical data EPS mini gantry s

EPS mini gantry s	
Order number	50444422
Drive type	electrical, linear motor
Repeat accuracy	± 0.05 mm
- with external path measuring system (1 µm)	± 0.02 mm
Temperature range	0 ... 50 °C
Control block with 5/3, 5/2 or vacuum units	up to 6 valves

Type	X-axis		
Axis	PDL30	PDL40	PDL40-HP
Stroke horizontal	90, 130, 150, 230, 250, 330, 350, 430, 450, 530, 550, 630, 650, 730, 930, 1130, 1330 mm	70, 160, 170, 230, 280, 320, 370, 440, 460, 530, 580, 670, 880, 1060, 1270, 1480, 1660 mm	160, 200, 250, 320, 340, 410, 460, 550, 760, 940, 1150, 1360, 1540 mm
Maximum speed	3.2 m/s	3 m/s	2 m/s
Peak force	255 N	550 N	1024 N
Permanent force	51 N	145 N	203 N

Type	Y-axis	
Axis	PEL20-SL	PEL20
Stroke horizontal	80, 140, 210, 270, 370, 550, 640 mm	60, 130, 190, 290, 470, 560 mm
Maximum speed	6.8 m/s	4.8 m/s
Peak force	67 N	137 N
Permanent force	15 N	31 N

Type	Z-axis	
Axis	ES20	ES20
Stroke vertical	50 mm	100, 200, 300 mm
Maximum speed	6.8 m/s	4.8 m/s
Peak force	67 N	137 N
Permanent force	15 N	31 N

Included in the delivery *

- 2x Ø 5h6 Centring sleeves
- 2x Ø 7h6 Centring sleeves
- MagSpring or compensation spring
- Hose or drag chain
- Motor cable
- Completely wired
- Controller parametrised
- Gantry bracing
- Attachment blocs

* Deviations possible depending on installed peripherals

Accessories

- (Catalogue HT accessories)
- Valve block
 - Clamping element
 - (Catalogue HT components linear)
 - Path measuring system
 - (Catalog HT components gripping/rotating)
 - Rotary module
 - Gripper module

3.15.3 Module loads EPS mini gantry s

Type	ES20-SL	ES20
Dynamic torque Mx	5 Nm	5 Nm
Dynamic torque My	25 Nm	50 Nm
Dynamic torque Mz	25 Nm	50 Nm

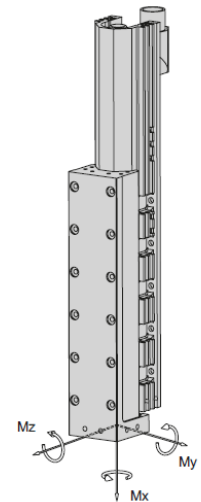

Payload (centric)			
Stroke Y	60 - 270 mm	290 - 370 mm	470 - 640 mm
Stroke Z			
50 mm	4 kg	3 kg	2 kg
100 mm	3 kg	2 kg	1 kg
200 mm	2 kg	1 kg	-
300 mm	1 kg	-	-

Cycle times EPS mini gantry s for Pick & Place

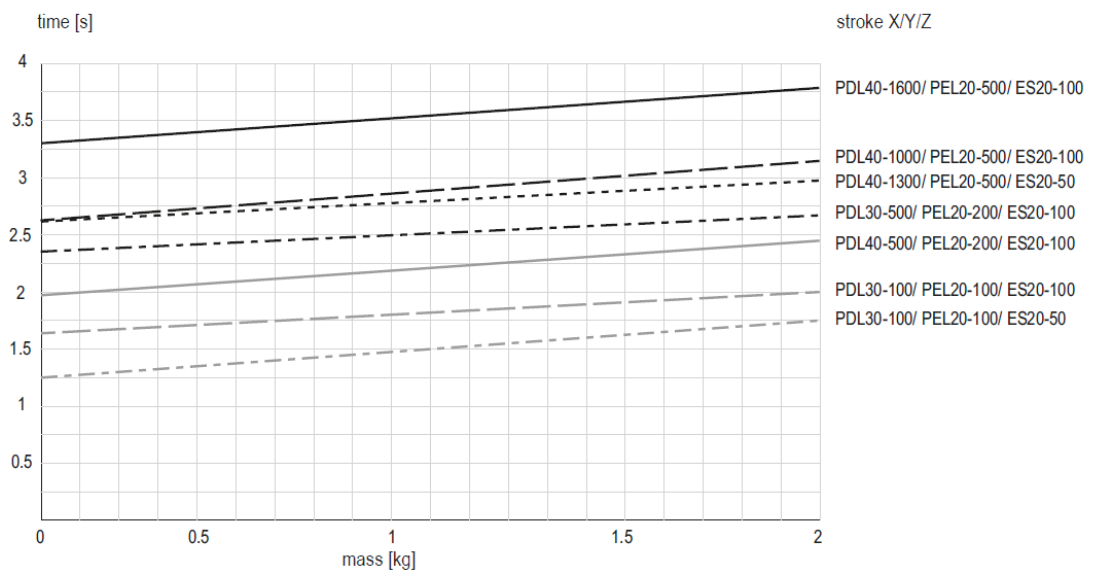

Times including 2 x 100 ms gripping time

Comment:

The values in the chart correspond to a Pick-and-Place cycle (6 subsequent movements + 2 × 100 ms gripping time). The indicated mass is centrally installed at the vertical linear unit. Standstill times of handling permit shorter movement times. In exceptions, e.g. at eccentric mass or high requirements to accuracy, the value may be exceeded.

3.16.2 Technical data EPS midi gantry s

EPS midi gantry s
Order number **50444423**

Drive type	electrical, linear motor
Repeat accuracy	± 0.05 mm
- with external path measuring system (1 µm)	± 0.02 mm
Temperature range	0 ... 50 °C
Control block with 5/3, 5/2 or vacuum units	up to 6 valves

Type	X-axis	
Axis	PDL40	PDL40-HP
Stroke horizontal	70, 160, 170, 230, 280, 320, 370, 440, 460, 530, 580, 670, 880, 1060, 1270, 1480, 1660 mm	160, 200, 250, 320, 340, 410, 460, 550, 760, 940, 1150, 1360, 1540 mm
Maximum speed	3 m/s	2 m/s
Peak force	550 N	1024 N
Permanent force	145 N	203 N

Type	Y-axis		
Axis	PDL30	PDL40	PDL40-HP
Stroke horizontal	90, 130, 150, 230, 250, 330, 350, 430, 450, 530, 550, 630 mm	70, 160, 170, 230, 280, 320, 370, 440, 460, 530, 580 mm	160, 200, 250, 320, 340, 410, 460, 550 mm
Maximum speed	3.2 m/s	3 m/s	2 m/s
Peak force	255 N	550 N	1024 N
Permanent force	51 N	145 N	203 N

Type	Z-axis	
Axis	ES20	ES20
Stroke vertical	50 mm	100, 200, 300 mm
Maximum speed	6.8 m/s	4.8 m/s
Peak force	67 N	137 N
Permanent force	15 N	31 N

Included in the delivery *

- 2x Ø 5h6 Centring sleeves
- 2x Ø 7h6 Centring sleeves
- MagSpring or compensation spring
- Hose or drag chain
- Motor cable
- Completely wired
- Controller parametrised
- Gantry bracing
- Attachment blocs

* Deviations possible depending on installed peripherals

Accessories

- (Catalogue HT accessories)
- Valve block
 - Clamping element
- (Catalogue HT components linear)
- Path measuring system
- (Catalog HT components gripping/rotating)
- Rotary module
 - Gripper module

3.16.3 Module loads EPS midi gantry s

Type	ES20-SL	ES20
Dynamic torque Mx	5 Nm	5 Nm
Dynamic torque My	25 Nm	50 Nm
Dynamic torque Mz	25 Nm	50 Nm

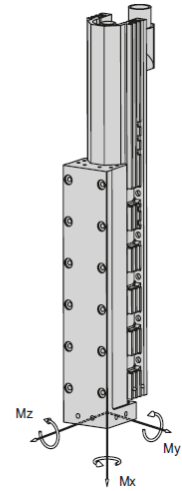

Payload (centric)				
Stroke Y	60 - 230 mm	250 - 430 mm	450 - 630 mm	
Stroke Z				
50 mm	4 kg	3 kg	1.5 kg	
100 mm	3 kg	2 kg	1 kg	
200 mm	2 kg	1 kg	0.5 kg	
300 mm	1 kg	0.5 kg	-	

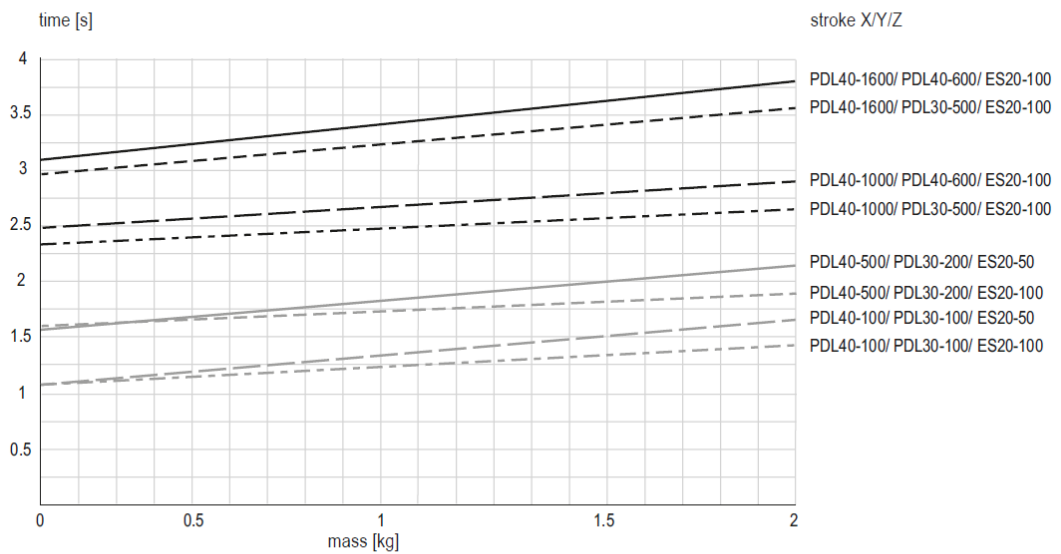
Cycle times EPS midi gantry s for Pick & Place

Times including 2 x 100 ms gripping time

Comment:

The values in the chart correspond to a Pick-and-Place cycle (6 subsequent movements + 2 x 100 ms gripping time). The indicated mass is centrally installed at the vertical linear unit. Standstill times of handling permit shorter movement times. In exceptions, e.g. at eccentric mass or high requirements to accuracy, the value may be exceeded.

3.17.2 Technical data EPS maxi gantry s

EPS maxi gantry s
Order number **50444424**

Drive type	electrical, linear motor
Repeat accuracy	± 0.05 mm
- with external path measuring system (1 µm)	± 0.02 mm
Temperature range	0 ... 50 °C
Control block with 5/3, 5/2 or vacuum units	up to 6 valves

Type	X-axis	
Axis	PDL40	PDL40-HP
Stroke horizontal	70, 160, 170, 230, 280, 320, 370, 440, 460, 530, 580, 670, 880, 1060, 1270, 1480, 1660 mm	160, 200, 250, 320, 340, 410, 460, 550, 760, 940, 1150, 1360, 1540 mm
Maximum speed	3 m/s	2 m/s
Peak force	550 N	1024 N
Permanent force	145 N	203 N

Type	Y-axis		
Axis	PDL30	PDL40	PDL40-HP
Stroke horizontal	90, 130, 150, 230, 250, 330, 350, 430, 450, 530, 550, 630 mm	70, 160, 170, 230, 280, 320, 370, 440, 460, 530, 580 mm	160, 200, 250, 320, 340, 410, 460, 550 mm
Maximum speed	3.2 m/s	3 m/s	2 m/s
Peak force	255 N	550 N	1024 N
Permanent force	51 N	145 N	203 N

Type	Z-axis
Axis	ES30
Stroke vertical	50, 100, 200, 300 mm
Maximum speed	3.2 m/s
Peak force	255 N
Permanent force	51 N

Included in the delivery *

- 2x Ø 7h6 Centring sleeves
- 2x Ø 9h7 Centring sleeves
- MagSpring
- Hose or drag chain
- Motor cable
- Completely wired
- Controller parametrised
- Gantry bracing
- Attachment blocs

* Deviations possible depending on installed peripherals

Accessories

- (Catalogue HT accessories)
- Valve block
 - Clamping element
(Catalogue HT components linear)
 - Path measuring system
(Catalog HT components gripping/rotating)
 - Rotary module
 - Gripper module

3.17.3 Module loads EPS maxi gantry s

Type	ES30-SL	ES30
Dynamic torque Mx	30 Nm	30 Nm
Dynamic torque My	40 Nm	80 Nm
Dynamic torque Mz	40 Nm	80 Nm

Payload (centric)				
Stroke Z	Stroke Y	70 - 230 mm	250 - 430 mm	450 - 630 mm
50 mm		5 kg	4 kg	3 kg
100 mm		4 kg	3 kg	2 kg
200 mm		3 kg	2 kg	1 kg
300 mm		2 kg	1 kg	-

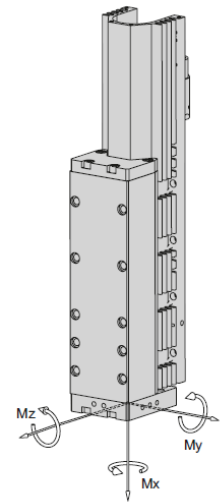

Cycle times EPS maxi gantry s for Pick & Place

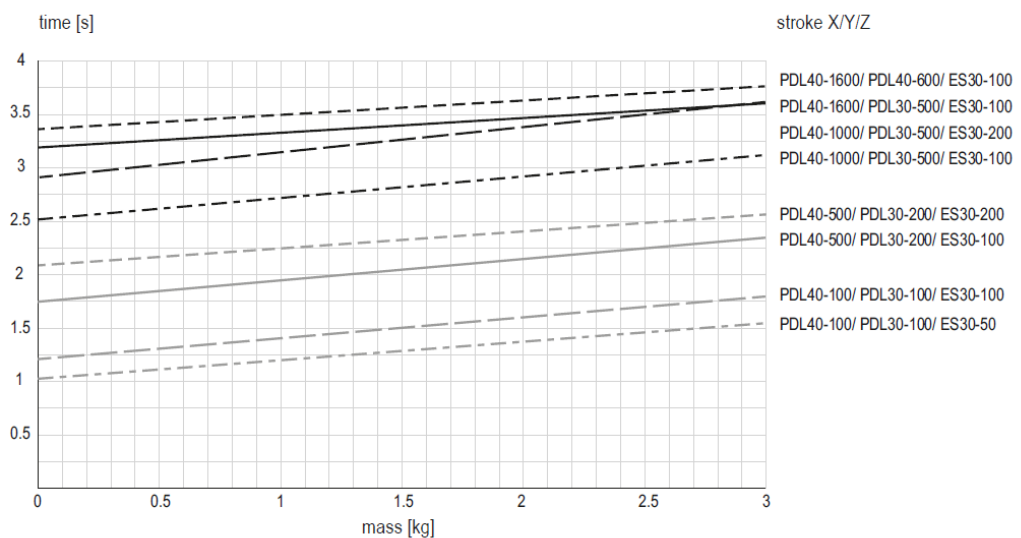

Times including 2 x 100 ms gripping time

Comment:

The values in the chart correspond to a Pick-and-Place cycle (6 subsequent movements + 2 x 100 ms gripping time). The indicated mass is centrally installed at the vertical linear unit. Standstill times of handling permit shorter movement times. In exceptions, e.g. at eccentric mass or high requirements to accuracy, the value may be exceeded.

3.18 EPS mini gantry h

3.18.1 Dimensioned drawing EPS mini gantry h

Type	A	B	C	D	E
PDL30-X-D19	X + 270 mm			40 mm	
PDL30-X-D20	X + 290 mm			50 mm	
PDL40-X-D27	X + 340 mm			49 mm	
PDL40-X-D28	X + 370 mm			64 mm	
PDL40-X-HP-D27	X + 460 mm			49 mm	
PDL40-X-HP-D28	X + 490 mm			64 mm	
PEL20-Y-SL		Y + 234 mm			114 mm
PEL20-Yw		Y + 314 mm			155 mm
ES20-50-SL			192 mm		
ES20-100-SL			285 mm		

- ① MagSpring
- ② Path measuring system
- X Stroke of the X-axis
- Y Stroke of the Y-axis

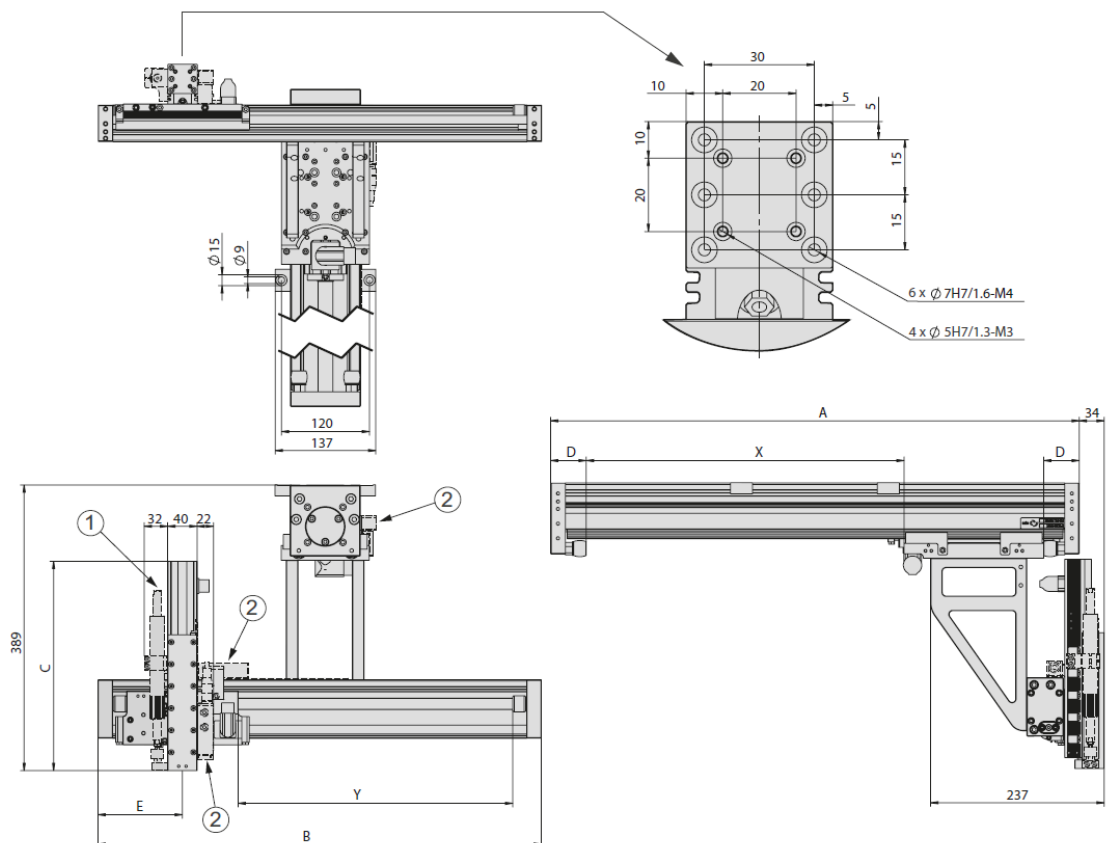

Fig. 18 Dimensioned drawing EPS mini gantry h

3.18.2 Technical data EPS mini gantry h

EPS mini gantry h
Order number **50444419**

Drive type	electrical, linear motor
Repeat accuracy	± 0.05 mm
- with external path measuring system (1 µm)	± 0.02 mm
Temperature range	0 ... 50 °C
Control block with 5/3, 5/2 or vacuum units	up to 6 valves

Type	X-axis	
Axis	PDL30	PDL40
Stroke horizontal	90, 130, 150, 230, 250, 330, 350, 430, 450, 530, 550, 630, 650, 730, 930, 1130, 1330 mm	70, 160, 170, 230, 280, 320, 370, 440, 460, 530, 580, 670, 880, 1060, 1270, 1480, 1660 mm
Maximum speed	3.2 m/s	3 m/s
Peak force	255 N	550 N
Permanent force	51 N	145 N

Type	Y-axis	
Axis	PEL20-SL	PEL20
Stroke horizontal	80, 140, 210, 270, 370, 550, 640 mm	60, 130, 190, 290, 470, 560 mm
Maximum speed	6.8 m/s	4.8 m/s
Peak force	67 N	137 N
Permanent force	15 N	31 N

Type	Z-axis	
Axis	ES20	ES20
Stroke vertical	50 mm	100 mm
Maximum speed	6.8 m/s	4.8 m/s
Peak force	67 N	137 N
Permanent force	15 N	31 N

Included in the delivery *

- 2x Ø 5h6 Centring sleeves
- 2x Ø 7h6 Centring sleeves
- MagSpring or compensation spring
- Hose or drag chain
- Motor cable
- Completely wired
- Controller parametrised
- Gantry bracing
- Attachment blocs

* Deviations possible depending on installed peripherals

Accessories

- (Catalogue HT accessories)
- Valve block
 - Clamping element
- (Catalogue HT components linear)
- Path measuring system
- (Catalog HT components gripping/rotating)
- Rotary module
 - Gripper module

3.18.3 Module loads EPS mini gantry h

Type	ES20-SL	ES20
Dynamic torque Mx	5 Nm	5 Nm
Dynamic torque My	25 Nm	50 Nm
Dynamic torque Mz	25 Nm	50 Nm

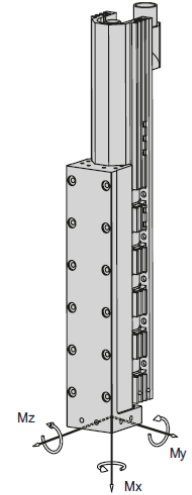

Payload (centric)		
Stroke Y	60 - 370 mm	470 - 640 mm
Stroke Z		
50 mm	4 kg	3 kg
100 mm	3 kg	2 kg

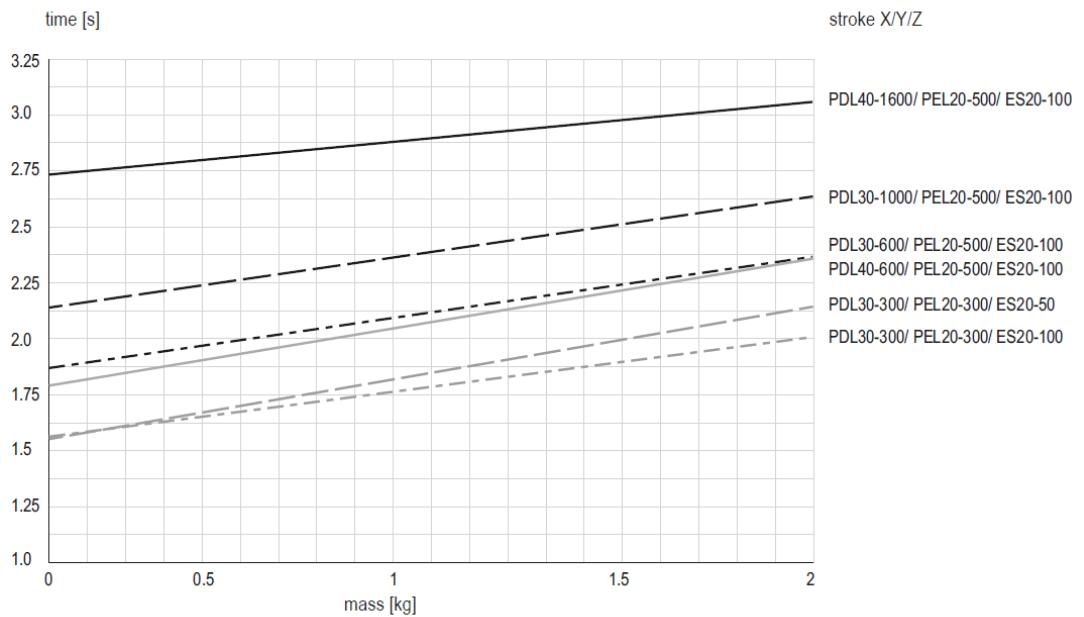
Cycle times EPS mini gantry h for Pick & Place

Times including 2 x 100 ms gripping time

Comment:

The values in the chart correspond to a Pick-and-Place cycle (6 subsequent movements + 2 x 100 ms gripping time). The indicated mass is centrally installed at the vertical linear unit. Standstill times of handling permit shorter movement times. In exceptions, e.g. at eccentric mass or high requirements to accuracy, the value may be exceeded.

3.19 EPS midi gantry h

3.19.1 Dimensioned drawing EPS midi gantry h

Type	A	C	D	E
PDL40-X-D27	X + 340 mm		49 mm	169 mm
PDL40-X-D28	X + 370 mm		64 mm	182 mm
PDL40-X-HP-D27	X + 460 mm		49 mm	230 mm
PDL40-X-HP-D28	X + 490 mm		64 mm	242 mm
PDL30-X-D19	X + 270 mm		40 mm	134 mm
PDL30-X-D20	X + 290 mm		50 mm	144 mm
ES20-50		192 mm		
ES20-100		285 mm		
ES20-200		365 mm		
ES20-300		495 mm		

- ① MagSpring
- ② Path measuring system
- X Stroke of the X-, Y-axis

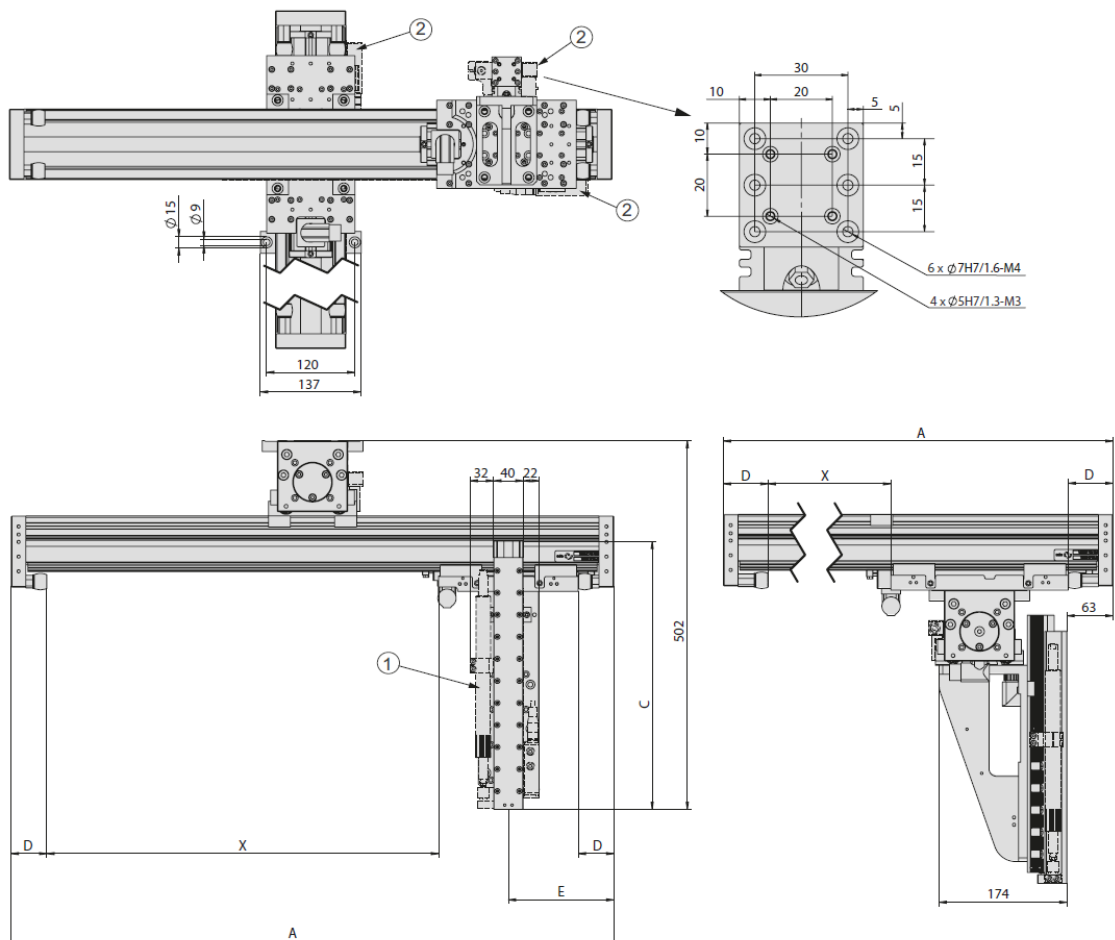

Fig. 19 Dimensioned drawing EPS midi gantry h

3.19.2 Technical data EPS midi gantry h

EPS midi gantry h
Order number **50444420**

Drive type	electrical, linear motor
Repeat accuracy	± 0.05 mm
- with external path measuring system (1 µm)	± 0.02 mm
Temperature range	0 ... 50 °C
Control block with 5/3, 5/2 or vacuum units	up to 6 valves

Type	X-axis	
Axis	PDL40	PDL40-HP
Stroke horizontal	70, 160, 170, 230, 280, 320, 370, 440, 460, 530, 580, 670, 880, 1060, 1270, 1480, 1660 mm	160, 200, 250, 320, 340, 410, 460, 550, 760, 940, 1150, 1360, 1540 mm
Maximum speed	3 m/s	2 m/s
Peak force	550 N	1024 N
Permanent force	145 N	203 N

Type	Y-axis		
Axis	PDL30	PDL40	PDL40-HP
Stroke horizontal	90, 130, 150, 230, 250, 330, 350, 430, 450, 530, 550, 630, 650, 730, 930, 1130 mm	70, 160, 170, 230, 280, 320, 370, 440, 460, 530, 580, 670, 880, 1060 mm	160, 200, 250, 320, 340, 410, 460, 550, 760, 940 mm
Maximum speed	3.2 m/s	3 m/s	2 m/s
Peak force	255 N	550 N	1024 N
Permanent force	51 N	145 N	203 N

Type	Z-axis			
Axis	ES20	ES20	ES20	ES20
Stroke vertical	50 mm	100 mm	200 mm	300 mm
Maximum speed	6.8 m/s	4.8 m/s	4.8 m/s	4.8 m/s
Peak force	67 N	137 N	137 N	137 N
Permanent force	15 N	31 N	31 N	31 N

Included in the delivery *

- 2x Ø 5h6 Centring sleeves
- 2x Ø 7h6 Centring sleeves
- MagSpring or compensation spring
- Hose or drag chain
- Motor cable
- Completely wired
- Controller parametrised
- Gantry bracing
- Attachment blocs

* Deviations possible depending on installed peripherals

Accessories

- (Catalogue HT accessories)
- Valve block
 - Clamping element
- (Catalogue HT components linear)
- Path measuring system
- (Catalog HT components gripping/rotating)
- Rotary module
 - Gripper module

3.19.3 Module loads EPS midi gantry h

Type	ES20-SL	ES20
Dynamic torque Mx	5 Nm	5 Nm
Dynamic torque My	25 Nm	50 Nm
Dynamic torque Mz	25 Nm	50 Nm

Payload (centric)		
Stroke Y	90 - 630 mm	670 - 1130 mm
Stroke Z		
50 mm	4 kg	3 kg
100 mm	3 kg	2 kg
200 mm	1 kg	0.5 kg
300 mm	0.5 kg	-

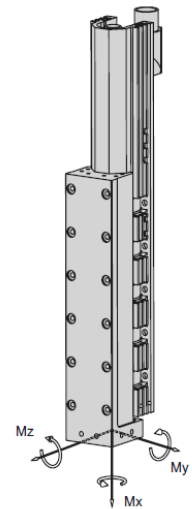

Cycle times EPS midi gantry h for Pick & Place

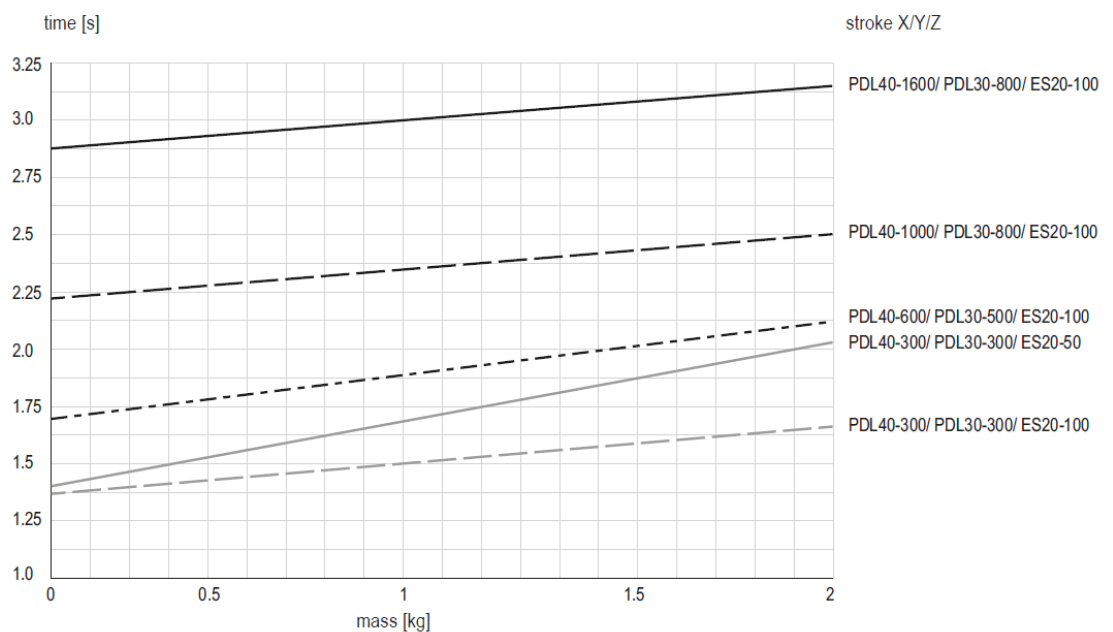

Times including 2 x 100 ms gripping time

Comment:

The values in the chart correspond to a Pick-and-Place cycle (6 subsequent movements + 2 × 100 ms gripping time). The indicated mass is centrally installed at the vertical linear unit. Standstill times of handling permit shorter movement times. In exceptions, e.g. at eccentric mass or high requirements to accuracy, the value may be exceeded.

3.20 EPS maxi gantry h

3.20.1 Dimensioned drawing EPS maxi gantry h

Type	A	D	E
PDL40-X-D27	X + 340 mm	49 mm	169 mm
PDL40-X-D28	X + 370 mm	64 mm	182 mm
PDL40-X-HP-D27	X + 460 mm	49 mm	230 mm
PDL40-X-HP-D28	X + 490 mm	64 mm	242 mm
PDL30-X-D19	X + 270 mm	40 mm	134 mm
PDL30-X-D20	X + 290 mm	50 mm	144 mm

Type	C
ES30-50-SL	288 mm
ES30-100-SL	328 mm
ES30-100	328 mm
ES30-200-SL	428 mm
ES30-200	428 mm
ES30-300	528 mm

- ① MagSpring
- ② Path measuring system
- X Stroke of the X-, Y-axis

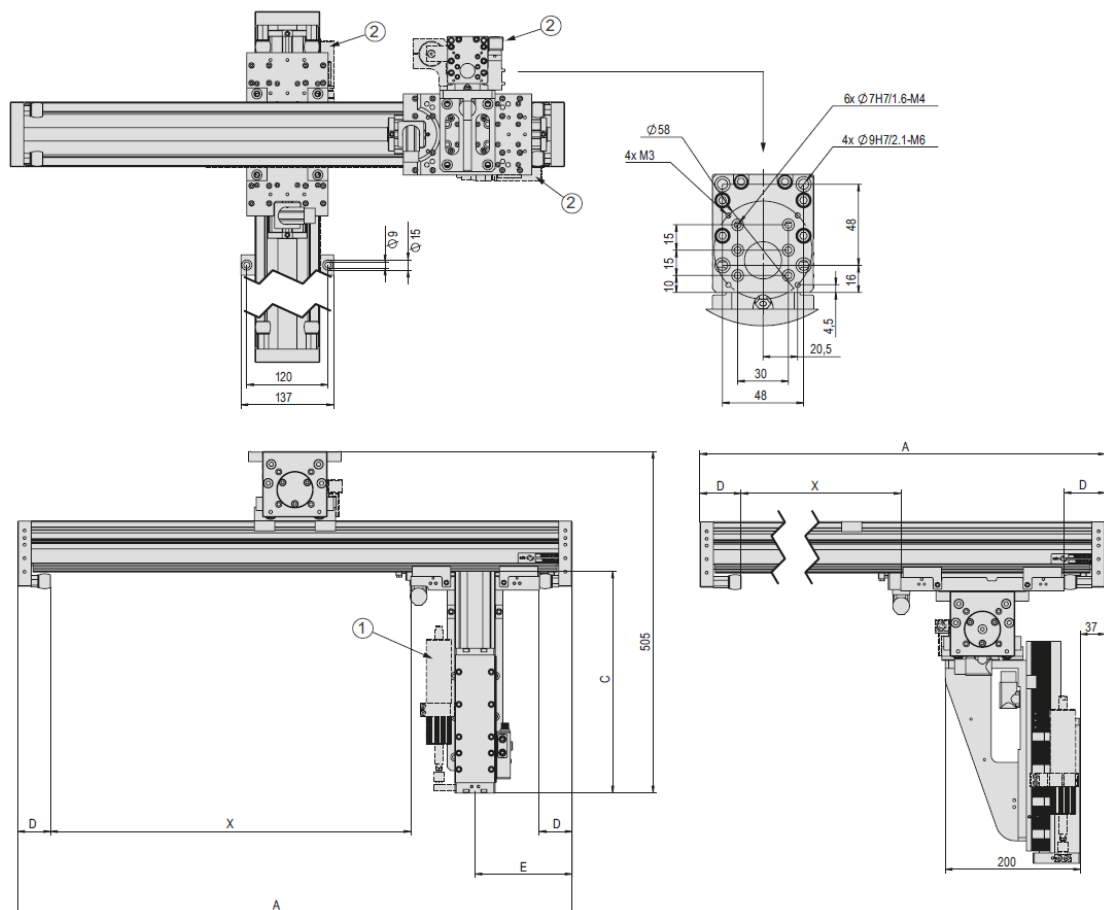

Fig. 20 Dimensioned drawing EPS maxi gantry h

3.20.2 Technical data EPS maxi gantry h

EPS maxi gantry h
Order number **50444421**

Drive type	electrical, linear motor
Repeat accuracy	± 0.05 mm
- with external path measuring system (1 µm)	± 0.02 mm
Temperature range	0 ... 50 °C
Control block with 5/3, 5/2 or vacuum units	up to 6 valves

Type	X-axis	
Axis	PDL40	PDL40-HP
Stroke horizontal	70, 160, 170, 230, 280, 320, 370, 440, 460, 530, 580, 670, 880, 1060, 1270, 1480, 1660 mm	160, 200, 250, 320, 340, 410, 460, 550, 760, 940, 1150, 1360, 1540 mm
Maximum speed	3 m/s	2 m/s
Peak force	550 N	1024 N
Permanent force	145 N	203 N

Type	Y-axis		
Axis	PDL30	PDL40	PDL40-HP
Stroke horizontal	90, 130, 150, 230, 250, 330, 350, 430, 450, 530, 550, 630, 650, 730, 930, 1130 mm	70, 160, 170, 230, 280, 320, 370, 440, 460, 530, 580, 670, 880, 1060 mm	160, 200, 250, 320, 340, 410, 460, 550, 760, 940 mm
Maximum speed	3.2 m/s	3 m/s	2 m/s
Peak force	255 N	550 N	1024 N
Permanent force	51 N	145 N	203 N

Type	Z-axis
Axis	ES30
Stroke vertical	50, 100, 200, 300 mm
Maximum speed	3.2 m/s
Peak force	255 N
Permanent force	51 N

Included in the delivery *

- 2x Ø 7h6 Centring sleeves
- 2x Ø 9h7 Centring sleeves
- MagSpring
- Hose or drag chain
- Motor cable
- Completely wired
- Controller parametrised
- Gantry bracing
- Attachment blocs

* Deviations possible depending on installed peripherals

Accessories

(Catalogue HT accessories)

- Valve block
- Clamping element
- (Catalogue HT components linear)
- Path measuring system
- (Catalog HT components gripping/rotating)
- Rotary module
- Gripper module

3.20.3 Module loads EPS maxi gantry h

Type	ES30-SL	ES30
Dynamic torque Mx	30 Nm	30 Nm
Dynamic torque My	40 Nm	80 Nm
Dynamic torque Mz	40 Nm	80 Nm

Payload (centric)		
Stroke Y	90 - 630 mm	670 - 1130 mm
Stroke Z		
50 mm	5 kg	3 kg
100 mm	4 kg	2 kg
200 mm	3 kg	1 kg
300 mm	0.5 kg	-

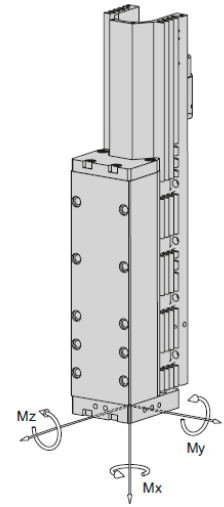
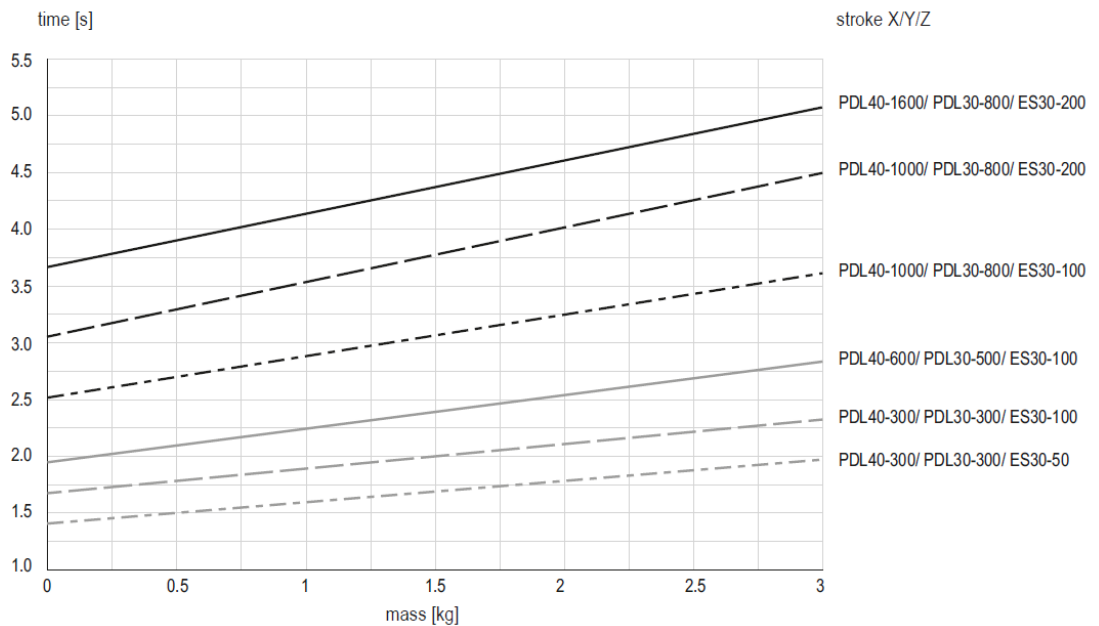
Cycle times EPS maxi gantry h for Pick & Place

Times including 2 x 100 ms gripping time

Comment:

The values in the chart correspond to a Pick-and-Place cycle (6 subsequent movements + 2 × 100 ms gripping time). The indicated mass is centrally installed at the vertical linear unit. Standstill times of handling permit shorter movement times. In exceptions, e.g. at eccentric mass or high requirements to accuracy, the value may be exceeded.

3.21 Overview of power supplies



For detailed installation instructions, please refer to the respective installation instructions of the power supply unit used.

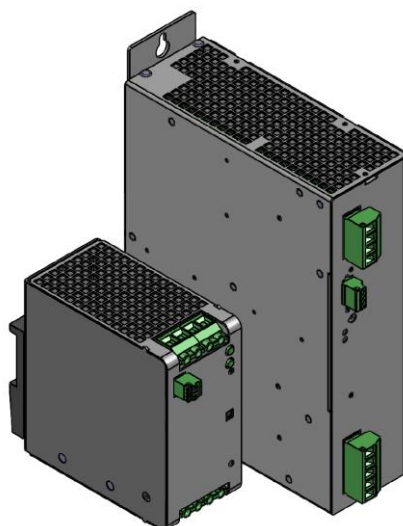

Fig. 21 Power supplies

Technical data	SPH500-7207	SPH1013-7214	NT01-72/1500Multi
Type	primary switched power supply		
Primary voltage	90-132 VAC, 50/60 Hz or 180-264 VAC, 50/60 Hz (automatic switching)	3x340 – 550 VAC, 50/60 Hz	3x230/400/480 VAC, 50/60 Hz
Secondary voltage	54-80 VDC adjustable	54-80 VDC adjustable	72 VDC
Output power	480 W	960 W	1500 W
Power consumption	600 W	1100 W	1500 W
Max. power loss	54 W	91 W	110 W
Peak output current (>0.5 s)	10 A	27 A	50 A
Rated current	240 VAC = 4.5 A, 120 VAC = 9 A	380 VAC = 3.1 A	3x230 VAC = 3.5 A, 400 VAC = 2 A, 480 VAC = 1.7 A
Efficiency	88%	91.5%	85% (at nominal power)
Protect. class	IP 20	IP 20	IP 20
Operating temperature	-25...70 °C	-25...70 °C	0...40 °C
Ground	1 kg	2 kg	17 kg
Dimension (HxWxD)	125x62x121 mm	230x66x177 mm	275x280x165 mm
External fuse	6 A (C, D, K Typ)	16-32 A (C, D, K Type)	8 A (C, D, K Typ)

4 Transport, packaging and storage

4.1 Safety instructions for transport

NOTICE

Risk of damage to property!

EPS systems are precision mechanical devices and can be damaged by incorrect handling.

EPS systems must be packed, transported, unpacked and stored with the necessary care and cleanliness.



Also observe the safety instructions in  chap. 2 „Safety instructions“ in this manual.

4.2 Transport



No liability can be assumed for damages caused by improper installation on the part of the operating company.



The following conditions must be complied with for transport and storage:

- Storage temperature: 0-50 °C
- Relative air humidity: < 90%, non condensing

4.3 Packaging

The EPS system is transported in the Afag transport packaging. If no Afag packaging is used, the EPS system must be packed in such a way that it is protected against shocks and dust.

The packaging materials used are mainly cardboard and paper or PE film. These are materials that can be recycled worldwide.

If the packaging is returned to us carriage paid, Afag will take it back free of charge and dispose of it properly.

NOTICE

Risk to the environment due to incorrect disposal of the packaging material

Environmental damage can be caused by incorrect disposal of the packaging material.

- Dispose of the packaging material in an environmentally sensitive way in accordance with the local environmental regulations.

4.4 Storage

If the EPS systems are stored for an extended period of time, observe the following:

- Store the EPS system in the transport packaging.
- Do not store the servo gripper outdoors or expose it to weather conditions.
- The storage space must be dry and dust free.
- Room temperature of the storage space: 0-50 °C.
- Relative air humidity: < 90% non condensing
- Clean the EPS and protect the blank metal parts against corrosion using the appropriate means.
- Protect the EPS system from dirt and dust.

5 Installation, assembly and setting

The EPS systems are incomplete machines. For safe operation, the system must be integrated into the safety concept of the system in which it is installed.

During normal operation, the user must not interfere with the working area of the EPS system. The user of the EPS system (plant operator) must ensure this by using suitable protective measures (e.g. protective bonnets, safety doors, enclosures, light grids).



The system operator is responsible for the installation of the EPS in a system!
No liability for damages can be assumed for damages caused by improper installation on the part of the operator.

5.1 Safety instructions for installation and assembly

CAUTION



Personal injury caused by hot surfaces!

High surface temperatures (up to 60°C) can occur on the EPS systems. There is a risk of injury and damage to property.

- No temperature-sensitive parts such as cables or electronic components may be in contact with or attached to the EPS system!
- Before touching hot surfaces without protective gloves, make sure they have cooled down to ambient temperature.

CAUTION



Risk of injuries due to uncontrolled parts movements!

When connecting to the control system and during operation of the EPS systems, unpredictable movements may occur and cause injury/property damage.

- Before working on the EPS system, make sure that the control unit is switched off and secured against being switched on again.



Also observe the safety instructions in  chapter 2 „Safety instructions“ in this manual.

5.2 Required mounting material

Depending on the EPS system used, the adapters used and the weights present, different tools and materials must be used. The following table contains recommendations for the use of the appropriate mounting material in each case.

Type	Recommended mounting material
SE20	<ul style="list-style-type: none"> ▪ 2/4x O-ring 2.5x0.62 NBR70 ▪ 4x cylindrical pin DIN 6325 4m6x10 ▪ 6x M4 screw (note screw-in depth)
SE30	<ul style="list-style-type: none"> ▪ 2/4x O-ring 2.5x0.62 NBR70 ▪ 4x cylindrical pin DIN 6325 4m6x10 ▪ 2x Ø 9h6 centring bushing + 4x screw M6x20 ▪ 2x Ø 7h6 centring bushing + 4x screw M4 ▪ 2x Ø 8h6 centring bushing + 4x screw M3
RA-40	<ul style="list-style-type: none"> ▪ 2/4x O-ring 2.5x0.62 NBR70 ▪ 2x screw M4 ▪ 4x screw M3 ▪ 2x centring bushing Ø7x3 ▪ 2x centring bushing Ø5x2.5
ES20	<ul style="list-style-type: none"> ▪ 4x Ø 7h6 centring bushing + 8x screw M4
ES30	<ul style="list-style-type: none"> ▪ 4x Ø 9h6 centring bushing + 4x screw M5
ES40	<ul style="list-style-type: none"> ▪ Centring bushing Ø12x4.8 ▪ 4x Centring bushing Ø12h6x4.8 ▪ 4x screw M8
PEL20	<ul style="list-style-type: none"> ▪ 2x Ø 9h6 centring bushing + 4x screw M6 ▪ 2x Ø 7h6 centring bushing + 4x screw M4 ▪ 2x Ø 5h6 centring bushing + 4x screw M3 ▪ 2x cylindrical pin 5m6 ▪ Mounting block for PEL20 PDL30_PDL40 + M8 screw
PDL30	<ul style="list-style-type: none"> ▪ 2x Ø 9h6 centring bushing + 4x screw M6 ▪ 2x Ø 7h6 centring bushing + 4x screw M4 ▪ 2x Ø 12h6 centring bushing + 4x screw M8 ▪ 2x cylindrical pin 8m6 ▪ Mounting block for PEL20 PDL30_PDL40 + M8 screw
PDL40	<ul style="list-style-type: none"> ▪ 2x Ø 9h6 centring bushing + 4x screw M6 ▪ 2x Ø 7h6 centring bushing + 4x screw M4 ▪ 2x Ø 12h6 centring bushing + 4x screw M8 ▪ 2x cylindrical pin 8m6 ▪ Mounting block for PEL20 PDL30_PDL40 + M8 screw



Only use original LinMot cables to operate the electric axes. The use of other cables can lead to damage or malfunctions!

5.3 Weight compensation

With the EPS system, the weight is balanced via the MagSpring or pneumatically unit (GWA).



Please also observe the installation instructions for the integrated modules!

5.3.1 Weight compensation with MagSpring



The following applies to both installation positions when mounting the MagSpring:

- The thread on the stator and the end of the rotor with 4 spanner flats point downwards.

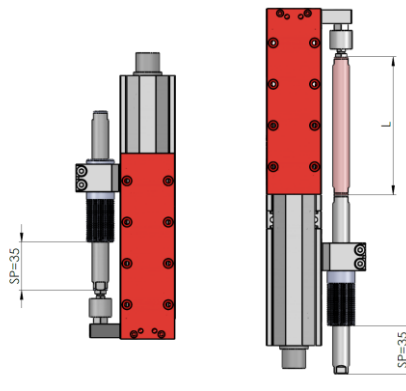

Fig. 22 Normal installation position - Inverted installation position

Normal installation position:

In normal installation position the dimension $SP=35$ mm is set by clamping the MagSpring stator with the slide fully **retracted**.

Inverted installation position:

With the installation position reversed, the dimension $SP=35$ mm is set by clamping the MagSpring stator with the slide fully **extended**.



The dimension L of the MagSpring extension depends on the stroke of the module used.

5.3.2 Weight compensation with pneumatic cylinder



Please observe the corresponding assembly instructions for the pneumatic weight compensation (GWA)!

5.4 Interfaces of the axis controllers

This chapter contains brief overviews of the interfaces of the various axis controllers. For further information on installation, please refer to the respective installation instructions. The controllers are pre-configured so that no software adjustment is usually necessary. If adjustments are necessary, please download the software "LinMot-Talk 1100": www.linmot.com.

5.4.1 Axis controller C11xx

Technical data	C1150-EC-XC	C1150-PN-XC	C1150-GP-XC
Weight	0,7 kg	0,7 kg	0,7 kg
Dimension BxHxT	26,6x206x106 mm	26,6x206x106 mm	26,6x206x106 mm
Logistics supply	24 VDC	24 VDC	24 VDC
Motor power supply	24 - 72 VDC	24 - 72 VDC	24 - 72 VDC
Max. motor output current (at 72 V)	25 A	25 A	25 A
Bus systems Interfaces	EtherCat CANopen DeviceNet RS485/232 Digital I/Os	<i>Profinet</i> CANopen DeviceNet RS485/232 Digital I/Os	CANopen DeviceNet RS485/232 Digital I/Os
Max. power consumption	30 W	30 W	30 W
Protect. class	IP 20	IP 20	IP 20
Operating temperature	0 - 40 °C	0 - 40 °C	0 - 40 °C
Ground	1.5 kg	1.5 kg	1.5 kg
Distance between controllers	20 mm left/right 50 mm bottom/top	20 mm left/right 50 mm bottom/top	20 mm left/right 50 mm bottom/top
Fuse protection 72 V supply	16 AT	16 AT	16 AT
Fuse protection 24 V supply	3 AT	3 AT	3 AT

Axis controller C11xx

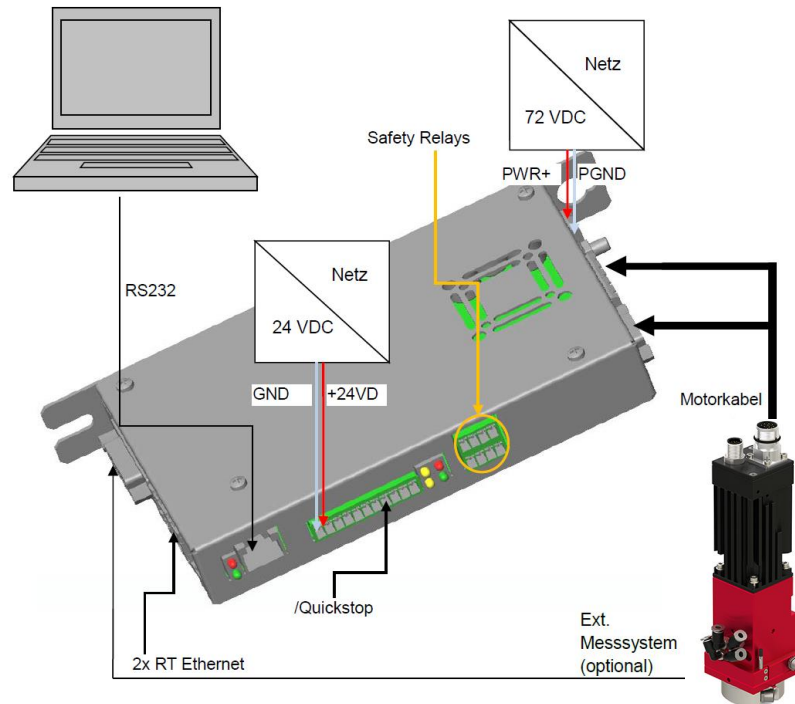

Fig. 23 Axis controller C11xx

Connection	Description
X1 PWR+	Motor power supply +72 VDC
X1 PGND	Motor power supply GND
X2	Motor phases
X3	Motor Signals
X33	Safety relay (optional for -S1 version)
X4.8	Quick stop (except PROFIdrive)
X4.7	Reference sensor (optional)
X4.2	Logic voltage supply +24 VDC
X4.1	Logic voltage supply GND

DANGER

Danger when the safety door is open!



There is a high risk of injury when the safety door is open!

- For the C11xx controller, the safety relay input (X33) must be deactivated or
- the power supply unit (72 V) must be disconnected on the primary side!

5.4.2 Axis controller C12xx

Technical data	C1250-EC-XC	C1250-IP-XC	C1250-PL-XC	C1250-PN-XC
Weight	0,7Kg	0,7Kg	0,7Kg	0,7Kg
Dimension BxHxT	25,3x216x106mm	25,3x216x106mm	25,3x216x106mm	25,3x216x106mm
Logistics supply	24 VDC	24 VDC	24 VDC	24 VDC
Motor power supply	24 - 72 VDC	24 - 72 VDC	24 - 72 VDC	24 - 72 VDC
Max. motor output current (at 72 V)	25 A	25 A	25 A	25 A
Bus systems Interfaces	EtherCat CANopen DeviceNet RS485/232 Digital I/Os Master encoder	Ethernet IP CANopen DeviceNet RS485/232 Digital I/Os Master encoder	PowerLink CANopen DeviceNet RS485/232 Digital I/Os Master encoder	Profinet CANopen DeviceNet RS485/232 Digital I/Os Master encoder
Max. power consumption	30 W	30 W	30 W	30 W
Protect. class	IP 20	IP 20	IP 20	IP 20
Operating temperature	0 - 40 °C	0 - 40 °C	0 - 40 °C	0 - 40 °C
Ground	0.7 kg	0.7 kg	0.7 kg	0.7 kg
Distance between controllers	20 mm left/right 50 mm bottom/top	20 mm left/right 50 mm bottom/top	20 mm left/right 50 mm bottom/top	20 mm left/right 50 mm bottom/top
Fuse protection 72 V supply	16 AT	16 AT	16 AT	16 AT
Fuse protection 24 V supply	3 AT	3 AT	3 AT	3 AT

Technical data	C1250-SC-XC	C1250-SE-XC	C1250-MI-XC
Weight	0,7Kg	0,7Kg	0,7Kg
Dimension BxHxT	25,3x216x106mm	25,3x216x106mm	25,3x216x106mm
Logistics supply	24 VDC	24 VDC	24 VDC
Motor power supply	24 - 72 VDC	24 - 72 VDC	24 - 72 VDC
Max. motor output current (at 72 V)	25 A	25 A	25 A
Bus systems Interfaces	Sercos III CANopen DeviceNet RS485/232 Digital I/Os Master encoder	Sercos over EtherCAT CANopen DeviceNet RS485/232 Digital I/Os Master encoder	PROFINET, PROFIdrive EtherCAT - DS402 – ETHERNET IP - CIP Sync POWERLINK SERCOS III LinUDP CC-Link RS485/232 Digitale I/Os Master Encoder
Max. power consumption	30 W	30 W	30 W
Protect. class	IP 20	IP 20	IP 20
Operating temperature	0 - 40 °C	0 - 40 °C	0 - 40 °C
Ground	0.7 kg	0.7 kg	0.7 kg
Distance between controllers	20 mm left/right 50 mm bottom/top	20 mm left/right 50 mm bottom/top	20 mm left/right 50 mm bottom/top
Fuse protection 72 V Supply	16 AT	16 AT	16 AT
Fuse protection 24 V supply	3 AT	3 AT	3 AT

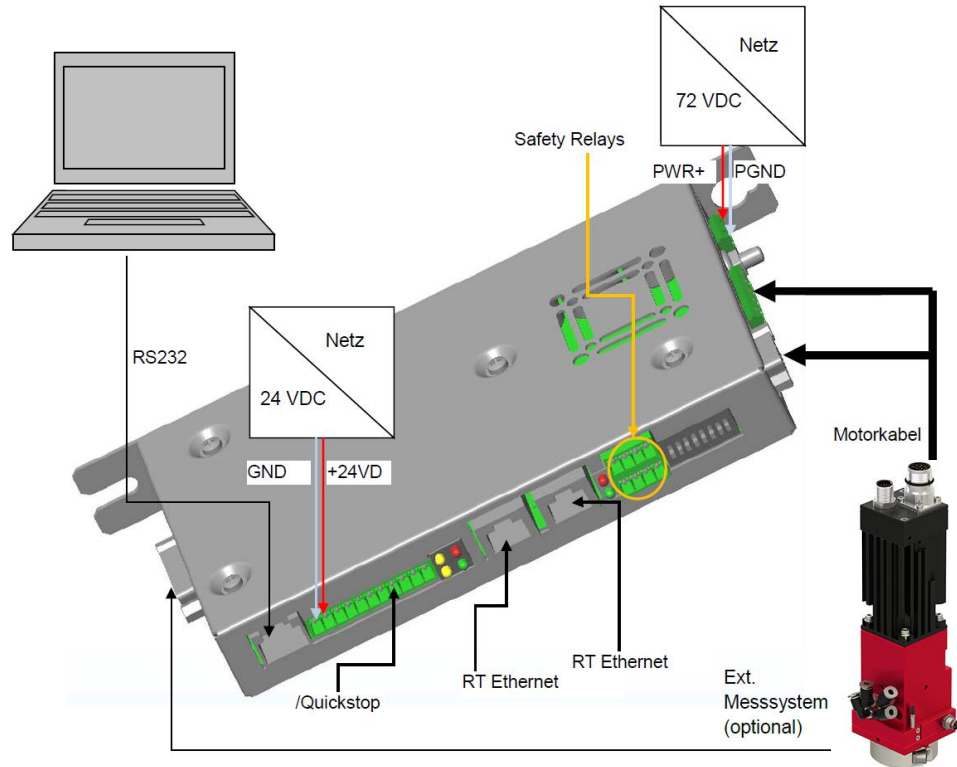

Fig. 24 Axis controller C12xx

Connection	Description
X1 PWR+	Motor power supply +72 VDC
X1 PGND	Motor power supply GND
X2	Motor phases
X3	Motor Signals
X33	Safety relay (optional for -S1 version)
X4.8	Quick stop (except PROFIdrive)
X4.7	Reference sensor (optional)
X4.2	Logic voltage supply +24 VDC
X4.1	Logic voltage supply GND

DANGER

Danger when the safety door is open!



There is a high risk of injury when the safety door is open!

- For the C12xx controller, the safety relay input (X33) must be deactivated or
- the power supply unit (72 V) must be disconnected on the primary side!

5.4.3 Axis controller C1251-Mi-2S enhanced security

C12xx	
Operating temperature	0 - 40 °C
Bearing temperature	-25 - 70 °C
Humidity	< 90 %
Type	
	C1251 -MI-XC-2S-0E-000
Order number	50597688
Net weight	1.1 kg
Dimensions W x H x D	34x246x131 mm
Nominal output current	25 A
Max. power consumption	30 W
Supply voltage	24 - 72 VDC
Control voltage	22-26 VDC
Protection type	IP 20
Intermediate circuit voltage	24 - 80 VDC
Distance to controllers horizontal	20 mm
Distance to controllers vertical	50 mm
Programming interface	RS232 (RJ45)
Safety functions	STO (Safe Torque Off) SS1 (Safe Stop 1) SS2 (Safe Stop 2) SOS (Safe Operating Stop) SLS (Safe Limited Speed) SBC (Safe Brake Control) SBT (Safe Brake Test)
Standard interfaces for higher-level control	PROFINET PROFIdrive PROFIsafe EtherCAT-DS402-FSoE POWERLINK SERCOS III ETHERNET IP - CIP Sync LinUDP CC-Link



Abb. 25 Axis controller C1251-Mi-2S enhanced security

Connection	Description
X1 PWR+	Motor power supply +72VDC
X1 PGND	Motor power supply GND
X2	Motor phases
X3	Motor Signals
X4.8	Quickstop
X4.7	Reference sensor (optional)
X4.2	Logic power supply 24VDC
X4.1	Logic voltage supply GND
X49	Safe IO machine safety

DANGER

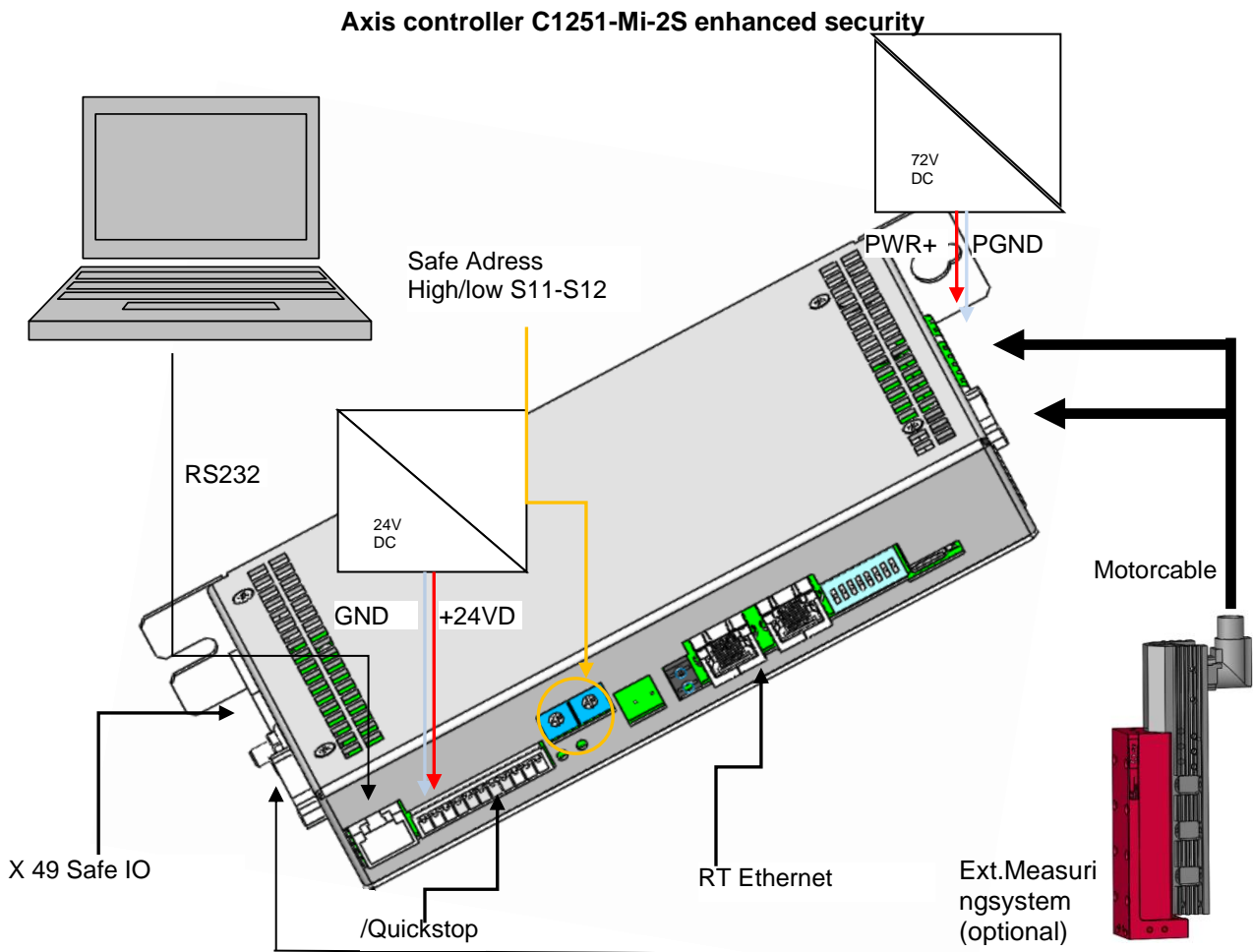

Danger from electric shock when the safety door is open!

Work on the electrical system carried out unprofessionally can cause serious or fatal injuries!

For the C1251-2S controller, control the safety relay input (X49) for SLS or via the Fieldbus Interface (Profissafe, FSOE).

5.4.1 Safety functions survey

Control (Safety-SPS)

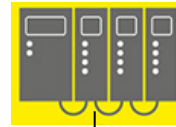

Axis controller (2S)
with enhanced safety





Motor cable



Axis (2S) with safety
linear motor

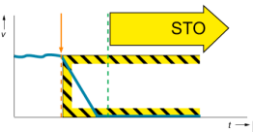
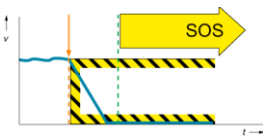

5.4.2 Available safety functions

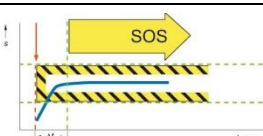
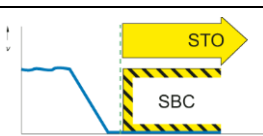
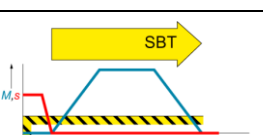
Function	Description	Diagram
STO	Safe Torque off	
SS1	Safe Stop 1	
SS2	Safe Stop 2	
SLS	Safe limited Speed (4 levels)	
SOS	Safe Operational Stop	
SBC	Safe Brake Control	
SBT	Safe Brake Test	

5.4.3 Axis controller E12xx

Technical data	E1230-DP-UC	E1250-EC-UC	E1250-PL-UC	E1250-SE-UC
Weight	1,7 kg	1,7 kg	1,7 kg	1,7 kg
Dimension BxHxT	40x270x180 mm	40x270x180 mm	40x270x180 mm	40x270x180 mm
Logistics supply	24 VDC	24 VDC	24 VDC	24 VDC
Motor power supply	24 - 72 VDC	24 - 72 VDC	24 - 72 VDC	24 - 72 VDC
Max. motor output current (at 72 V)	Standard version: 32 A	Standard version: 32 A	Standard version: 32 A	Standard version: 32 A
Bus systems Interfaces	Profibus CANopen DeviceNet RS485/232 Digital I/Os Master encoder	EtherCat CANopen DeviceNet RS485/232 Digital I/Os Master encoder	PowerLink CANopen DeviceNet RS485/232 Digital I/Os Master encoder	Sercos over EtherCAT CANopen DeviceNet RS485/232 Digital I/Os Master encoder
Max. power consumption	30 W	30 W	30 W	30 W
Protect. class	IP 20	IP 20	IP 20	IP 20
Operating temperature	0 - 40 °C	0 - 40 °C	0 - 40 °C	0 - 40 °C
Ground	1 kg	1 kg	1 kg	1 kg
Distance between controllers	20 mm left/right 50 mm bottom/top	20 mm left/right 50 mm bottom/top	20 mm left/right 50 mm bottom/top	20 mm left/right 50 mm bottom/top
Fuse protection 72 V supply	20 AT	20 AT	20 AT	20 AT
Fuse protection 24 V supply	2 AT	2 AT	2 AT	2 AT

Technical data	E1250-IP-UC	E1250-PN-UC	E1250-SC-UC
Weight	1,7 kg	1,7 kg	1,7 kg
Dimension BxHxT	40x270x180 mm	40x270x180 mm	40x270x180 mm
Logistics supply	24 VDC	24 VDC	24 VDC
Motor power supply	24 - 72 VDC	24 - 72 VDC	24 - 72 VDC
Max. motor output current (at 72 V)	Standard version: 32 A	Standard version: 32 A	Standard version: 32 A
Bus systems Interfaces	Ethernet IP CANopen DeviceNet RS485/232 Digital I/Os Master encoder	Profinet CANopen DeviceNet RS485/232 Digital I/Os Master encoder	Sercos III CANopen DeviceNet RS485/232 Digital I/Os Master encoder
Max. power consumption	30 W	30 W	30 W
Protect. class	IP 20	IP 20	IP 20
Operating temperature	0 - 40 °C	0 - 40 °C	0 - 40 °C
Ground	1 kg	1 kg	1 kg
Distance between controllers	20 mm left/right 50 mm bottom/top	20 mm left/right 50 mm bottom/top	20 mm left/right 50 mm bottom/top
Fuse protection 72 V supply	20 AT	20 AT	20 AT
Fuse protection 24 V supply	2 AT	2 AT	2 AT

Axis controller E12xx

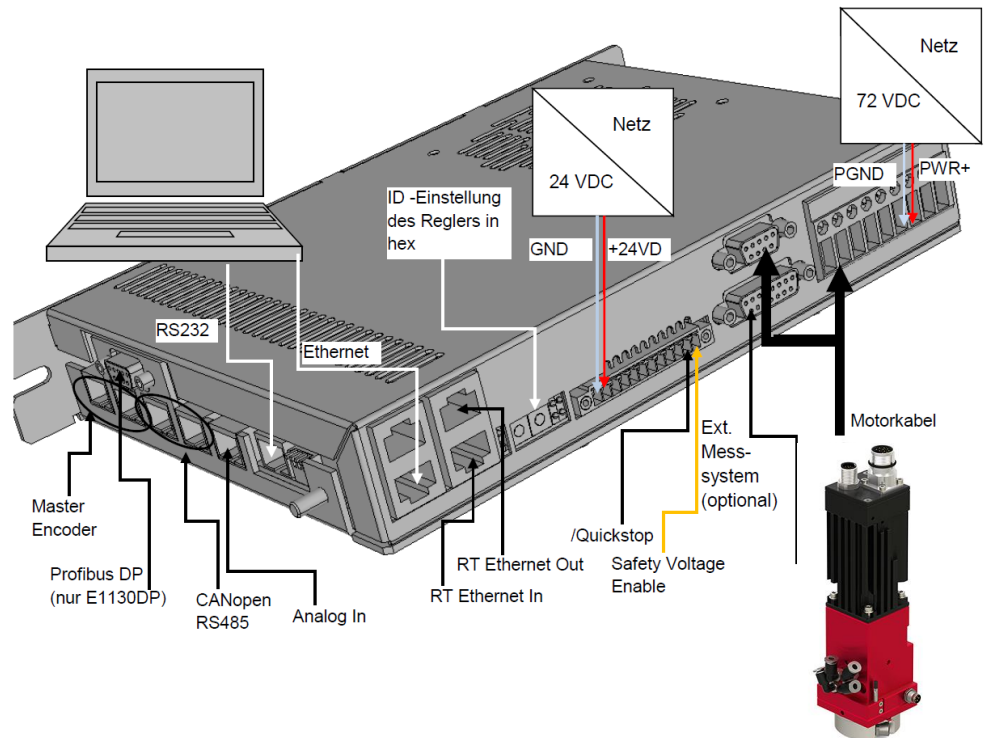

Fig. 26 Axis controller E12xx

Connection	Description
X1 PWR+	Motor power supply +72 VDC
X1 PGND	Motor power supply GND
X2	Motor phases
X3	Motor Signals
X4.12	Safety voltage enable
X4.11	/Quick stop
X4.7	Reference sensor (optional)
X4.2	Logic voltage supply +24 VDC
X4.1	Logic voltage supply GND

DANGER





Danger when the safety door is open!

There is a high risk of injury when the safety door is open!

- With the E12xx controller, the power supply unit (72 V) must be safely disconnected on the primary side!

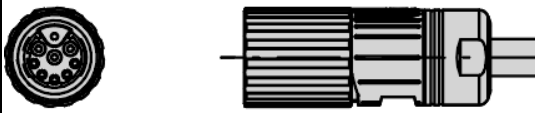
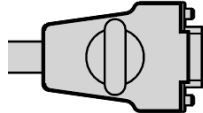
5.5 Pin assignment and electrical connection data of the motors

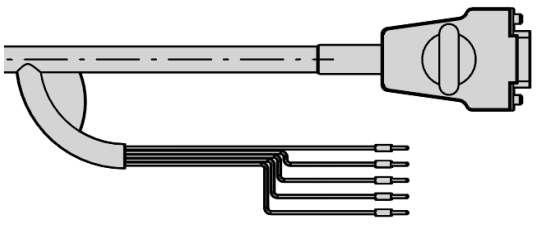
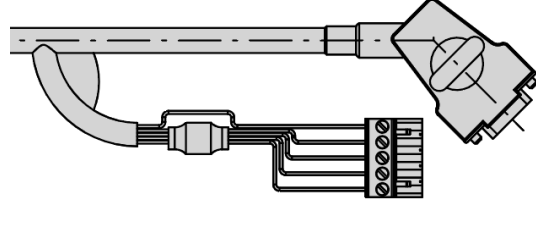
Connector combinations	
Connector on the axle	Connector on the controller
<p>R connector:</p>  <p>Insert</p> <ul style="list-style-type: none"> - Electric slide ES20 - Portal axis PEL20 - Rotary axis SE20 	<p>D connector:</p>  <p>Insert</p> <ul style="list-style-type: none"> -
<p>C connector:</p>  <p>Insert</p> <ul style="list-style-type: none"> - Electric slide ES30 - Portal axis PEL30 - Portal axis PDL30 - Portal axis PDL40 - Portal axis PDL40-HC - Rotary axis SE30 	<p>W connector:</p>  <p>Insert</p> <ul style="list-style-type: none"> - Controller E12xx UC <p>Y connector:</p>  <p>Insert</p> <ul style="list-style-type: none"> - Controller C11xx XC - Controller C12xx XC

5.5.1 Motor plug ES20, PEL20

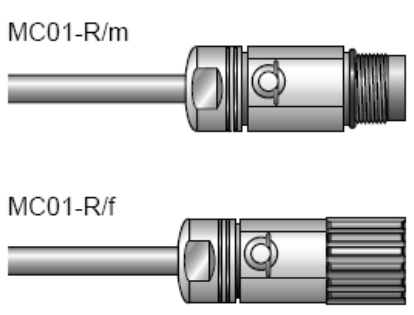
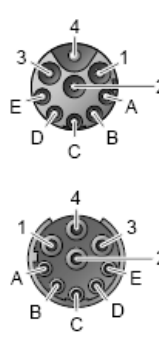
		PIN	Function	Color
		1	Phase 1+	red
		2	Phase 1-	pink
		3	Phase 2+	blue
		4	Phase 2-	grey
		A	+5V	white
		B	GND	inner shield
		C	Sensor Sinus	yellow
		D	Sensor Cosinus	green
		E	Temp. Sensor	black
		Gehäuse	shield	outer shield

Elektrik Motor data ES20/PEL20

Phase 1+ / Phase 1-	4 Ω
Phase 2+ / Phase 2-	4 Ω
+5V / GND	505 Ω
Sensor Sinus / GND	37,5kΩ
Sensor Cosinus / GND	37,5kΩ
Temp. Sensor / GND	10,5kΩ
All Phasen / GND	>20MΩ
All Pins / shield	>20MΩ

Elektrik Motor data ES20-2S/PEL20-2S

Phase 1+ / Phase 1-	3,8 Ω
Phase 2+ / Phase 2-	3,8 Ω
+5V / GND	3,53 kΩ
Sensor Sinus / GND	>10MΩ
Sensor Cosinus / GND	>10MΩ
Temp. Sensor / GND	13,5kΩ
All Phasen / GND	>20MΩ
All Pins / shield	>20MΩ

5.5.2 Motor plug ES30, ES40, PDL30, PDL40

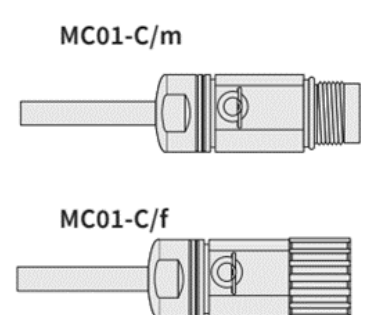
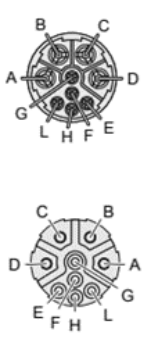
		PIN	Function	Color
		1	Phase 1+	red
		2	Phase 1-	pink
		3	Phase 2+	blue
		4	Phase 2-	grey
		A	+5V	white
		B	GND	inner shield
		C	Sensor Sinus	yellow
		D	Sensor Cosinus	green
		E	Temp. Sensor	black
		Housing	shield	outer shield

Elektrik Motor data ES30/PDL30

Phase 1+ / Phase 1-	2,6 Ω
Phase 2+ / Phase 2-	2,6 Ω
+5V / GND	6,3 kΩ
Sensor Sinus / GND	33 kΩ
Sensor Cosinus / GND	33 kΩ
Temp. Sensor / GND	10 kΩ
Alle Phasen / GND	>20MΩ
Alle Pins / shield	>20MΩ

Elektrik Motor data ES40/PDL40

Phase 1+ / Phase 1-	1,1 Ω
Phase 2+ / Phase 2-	1,1 Ω
+5V / GND	155 Ω
Sensor Sinus / GND	33 kΩ
Sensor Cosinus / GND	33 kΩ
Temp. Sensor / GND	10 kΩ
Alle Phasen / GND	>20MΩ
Alle Pins / shield	>20MΩ

Elektric Motor data ES30/PDL30-2S

Phase 1+ / Phase 1-	2,33 Ω
Phase 2+ / Phase 2-	2,33 Ω
+5V / GND	160 Ω
Sensor Sinus / GND	>10M Ω
Sensor Cosinus / GND	>10M Ω
Temp. Sensor / GND	10 k Ω
All Phases / GND	>20M Ω
All Pins / shield	>20M Ω

Elektric Motor data ES40/PDL40-2S

Phase 1+ / Phase 1-	0,95 Ω
Phase 2+ / Phase 2-	0,95 Ω
+5V / GND	160 Ω
Sensor Sinus / GND	>10M Ω
Sensor Cosinus / GND	>10M Ω
Temp. Sensor / GND	10 k Ω
All Phases / GND	>20M Ω
All Pins / shield	>20M Ω

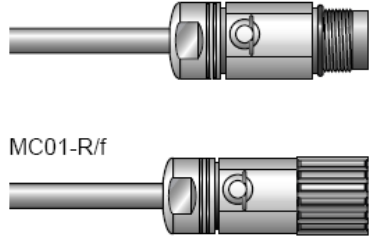
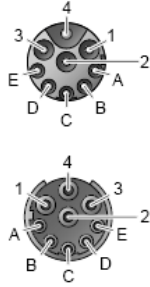

5.5.3 Motor plug RA40

		PIN	Function	Connection Ribbon cable	Color
		1	Phase 3	3	red
		2	Phase 2	2	pink
		3	Phase 1	1	blue
		4		-	grey
		A	+5V	5	white
		B	GND	4	inner shield
		C	Hallsensor A	8	yellow
		D	Hallsensor B	7	green
		E	Hallsensor C	6	black
		Gehäuse	Schirm	-	outer shield

Elektric Motor data RA40

Phase - Phase	4 Ω
+5V / GND	8,3 k Ω
Hall sensor A/B/C-GND	34 k Ω
All Phases / GND	>20M Ω
All Pins / shields	>20M Ω

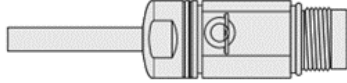
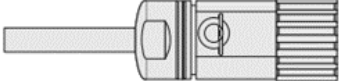
5.5.4 Motor plug SE30

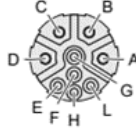
 <p>MC01-C/m</p>  <p>MC01-C/f</p>	 	PIN	Function	Color
		1	Phase 1+	red
	2	Phase 1-	pink	
	3	Phase 2+	blue	
	4	Phase 2-	grey	
	A	+5V	white	
	B	GND	inner shield	
	C	Hall sensor A	yellow	
	D	Hall sensor B	green	
	E	Hall sensor C	black	
	Housing	shield	outer shield	

Electric Motor data SE30

Phase - Phase	0,25 Ω
+5V / GND	6,3 k Ω
Hall sensor A/B/C-GND	33k Ω
All Phases / GND	>20M Ω
All Pins / shields	>20M Ω

5.6 Connector assignment encoder Path measuring system on the controller

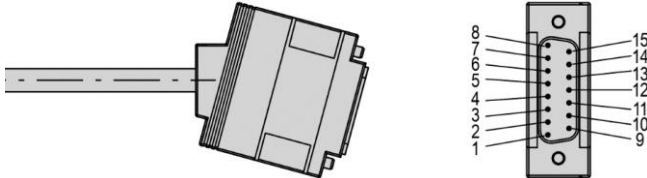
Controller C1xxx and E12xx series		PIN	Function	Colour
	1	+5V	pink	
	2	A- / sin-	yellow	
	3	B- / cos-	grey	
	4	Z- / data -	white	
	5	GND	red/blue+violet	
	6	Free	-	
	7	Free	-	
	8	Clock-	Green	
	9	A+ / sin+	Black	
	10	B+ / cos+	Red	
	11	Z+ /Data+	blue	
	12	Free	-	
	13	Free	-	
	14	Free	-	
	15	Clock+	grey/pink	
Housing	Screen	outer screen		

5.6.1 Connector assignment Sensor WMS MSA501

Cable plug S713 12polig M12x1	PIN	Function
	1	frei
	2	Z+ / Data+
	3	Z- /Data-
	4	Clock-
	5	+5V
	6	A-
	7	A+
	8	B-
	9	B+
	10	config
	11	Clock +
	12	GND
Housing	Screen	

5.6.2 Connector assignment Sensor WMS MSK500, MSK1000

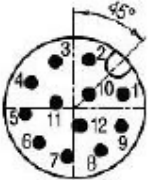
Cable plug S713 12polig M12x1	PIN	Function	Colour
	1	-	-
	2	Z+	blue
	3	Z-	violett
	4	-	-
	5	+5V	brown
	6	A-	yellow
	7	A+	red
	8	B-	green
	9	B+	orange
	10	-	-
	11	-	-
	12	GND	black
Housing	Screen	outer screen	

5.6.3 Connector assignment Sensor WMS MSA213C

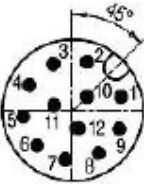
Cable plug S713 12polig M12x1 	PIN	Funktion	Colour
	1	-	-
	2	Z+ / Data+	grey
	3	Z- /Data-	white
	4	Clock-	violett
	5	+5V	brown
	6	A-	yellow
	7	A+	red
	8	B-	green
	9	B+	orange
	10	-	-
	11	MA (T+ RS485)	blue
	12	GND	black
Housing	Screen	outer screen	

5.6.4 Connector assignment Encoder IE3 (RA40/SE30)

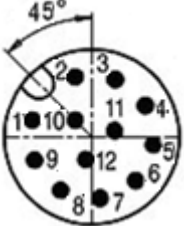
Flansch plug Serie 713 12polig M12x1 	PIN	Function	Colour
	1	-	-
	2	Z+	grey 10
	3	Z-	grey 9
	4	-	-
	5	+5V	grey 2
	6	A-	grey 5
	7	A+	grey 6
	8	B-	grey 7
	9	B+	grey 8
	10	frei	-
	11	frei	-
	12	GND	grey 3
Housing	Screen	-	

5.7 Connector strip

- Connector strip STL-4 for 4 sensors 4xM8, 3-pin, 1xM12 12-pin (16520814)
- Connector strip STL-6 for 6 sensors 6xM8, 3-pin, 1xM12 12-pin (16520815)
- Connector strip STL-8 for 8 sensors 8xM8, 3-pin, 1xM12 12-pin (16520685)
- Connector strip STL-10 for 10 sensors 10xM8, 3-pin, 1xM12 12-pin (16520816)

The power strip offers three essential functions:

- Connecting the sensors of the periphery
- Display 24 V supply
- Display of the switching states of the sensors

Suitable:

Angle plug series 768 3-pin M8x1 (16520057)

Connection cable 12-pin angled socket 10m (16520686)

Connection cable 12-pin angled socket 15m (16520833)

Pin assignment of connector strip

Function	Socket 12-pin PIN	Cable
+	1	brown
-	2	blue
X1	3	white
X2	4	green
X3	5	yellow
X4	6	grey
X5	7	pink
X6	8	red
X7	9	black
X8	10	violet
X9	11	grey/pink
X10	12	red/blue

Assignment of the sockets (3-pole)

Function	PIN	Cable
+	1	brown
Signal	4	black
-	3	blue

6 Commissioning



In addition, observe the instructions in the operating manuals of the respective individual modules!

6.1 Safety instructions for commissioning



DANGER

Danger! Risk of electric shock!

If work on electrical components is required, ensure that the work is carried out properly, failure to do so will cause serious or fatal injuries.

- Work on the machine's electrical equipment may only be performed by skilled electrician or trained personnel under the supervision of a skilled electrician in accordance with all relevant electrical regulations.



CAUTION

Danger of injury in the working area of the EPS!

Due to the decentralised control system, the operator of the EPS must not necessarily stand next to the module during operation so that he may not have a complete view of the working area. Persons in the working area may be injured.

- During operation, ensure a good overview of the working area.
- Unauthorised persons are not allowed in the work area.



CAUTION

Risk of injuries due to uncontrolled parts movements!

When the control is switched on, signals from the control can lead to unintentional movements of the EPS system and cause serious injuries or damage to property.

- Before working on the EPS system, make sure that the control unit is switched off and secured against being switched on again.
- Only connect or disconnect the cables when the control unit is switched off.



CAUTION

Risk of injury due to mounted components!

Attachments on the EPS system can be a risk in conjunction with moving parts.

- Take appropriate measures to ensure safe operation!



Also observe the safety instructions in  chap. 2 „Safety instructions“ in this manual.

6.2 Preparatory activities for commissioning

Before commissioning, all parameters must be precisely adjusted to the respective application or intended use.

To do this, make the settings on the individual modules as described at [chapter 6.4 "Settings"](#).

To prepare for commissioning proceed as follows:

1. Set the speeds on the electric axes ([chapter 6.4.1](#)).
 2. Teach positions on electric axes ([chapter 6.4.2](#)).
 3. Set the damping/speeds on the pneumatic modules ([chapter 6.4.3](#)).
 4. Set the external position measuring system ([chapter 6.4.4](#)).
- ⇒ The preliminary settings for commissioning are completed.

6.3 Commissioning of the modules

Proceed carefully and follow the instructions step by step when commissioning the modules for the first time:

1. Observe the permissible technical values ([chapter 3](#)).
 - Payload
 - Movement frequency
 - Momentary load
 2. First, make sure that there are no persons or tools in the working area.
 3. Perform test run:
 - Start with slow movements,
 - subsequently under normal operating conditions.
- ⇒ Commissioning is completed.

6.4 Settings

CAUTION



Danger of material damage and personal injury due to improperly performed adjustment work!

Improperly carried out activities can result in considerable material damage and serious injury.

- Only use trained specialist personnel to carry out the activities.



The EPS system is a precision mechanical device.

Please proceed with the necessary care and cleanliness during the setting work!

6.4.1 Set speeds on electric axes

The speeds of the electric axes are usually specified by the higher-level control system. For this purpose, there are sample programmes for many common controllers with which the maximum speed, acceleration and the target position can be specified.

These programmes are stored on the CD supplied or can be downloaded from <https://www.afag.com/de/service/support-tools/linmot.html> .

NOTICE

Risk of damage to property!

Excessive speed or acceleration can cause damage to the unit or peripherals.

- Observe the permissible values!

Table overview of the electric axes

The following tables should serve as a reference for the parameters (speed, acceleration and deceleration).



Please note that the standard parameters depend strongly on the load mass and the mechanical structure and must therefore be adapted to your application!

Type	Max. speed [m/s]	Max. accel. [m/s ²]	Max. delay [m/s ²]	Std. speed [m/s]	Std. accel. [m/s ²]	Std. delay [m/s ²]	Max. pos. [mm]	Min. pos. [mm]
SE20-x-50-x	0.84	30	30	0.84	20	20	∞	∞
SE20-x-30-x	1.7	20	20	1.7	15	15	∞	∞
SE30-x-50-x	0.84	30	30	0.84	20	20	∞	∞
SE30-x-30-x	1.7	20	20	1.7	15	15	∞	∞
RA-40-x-x-50-x-x	0.84	30	30	0.84	20	20	∞	∞
RA-40-x-x-30-x-x	1.7	20	20	1.7	15	15	∞	∞
ES20-50-SL	7.3	120	120	3	15	15	50	0
ES20-100-SL	5.3	80	80	3	10	10	100	0
ES20-200	5.3	60	60	3	10	10	200	0
ES20-300	5.3	40	40	3	10	10	300	0
ES30-050-SL	3.9	80	80	2	15	15	50	0
ES30-100-SL	3.9	80	80	2	15	15	100	0
ES30-100	3.9	80	80	2	15	15	100	0
ES30-200-SL	3.9	80	80	2	15	15	200	0
ES30-200	3.9	80	80	2	15	15	200	0
ES30-300	3.9	80	80	2	15	15	300	0
ES30-400	3.9	80	80	2	15	15	400	0
ES30-500	3.9	80	80	2	15	15	500	0
ES40-100-SL	2	20	80	2	15	15	100	0
ES40-100	2	20	80	2	15	15	100	0
ES40-200	2	20	80	2	15	15	200	0
ES40-300	2	18	80	2	15	15	200	0
ES40-400	2	18	80	2	15	15	300	0
ES40-500	1.8	18	80	2	15	15	400	0

Type	Max. speed [m/s]	Max. accel. [m/s ²]	Max. delay [m/s ²]	Std. speed [m/s]	Std. accel. [m/s ²]	Std. delay [m/s ²]	Max. pos. [mm]	Min. pos. [mm]
ES40-100-HP-SL	2	55	80	2	15	15	100	0
ES40-100-HP	2	48	80	2	15	15	100	0
ES40-200-HP	1.8	40	80	2	15	15	200	0
ES40-300-HP	1.8	37	80	2	15	15	200	0
ES40-400-HP	1.8	34	80	2	15	15	300	0
ES40-500-HP	1.7	30	80	2	15	15	400	0
PEL20-080-SL	7.3	120	120	3	15	15	80	0
PEL20-140-SL	7.3	120	120	3	15	15	140	0
PEL20-210-SL	7.3	120	120	3	15	15	210	0
PEL20-270-SL	7.3	120	120	3	15	15	270	0
PEL20-370-SL	7.3	120	120	3	15	15	370	0
PEL20-550-SL	7.3	120	120	3	15	15	550	0
PEL20-640-SL	7.3	120	120	3	15	15	640	0
PEL20-060	5.3	80	80	3	10	10	60	0
PEL20-130	5.3	80	80	3	10	10	130	0
PEL20-190	5.3	80	80	3	10	10	190	0
PEL20-290	5.3	80	80	3	10	10	290	0
PEL20-470	5.3	80	80	3	10	10	470	0
PEL20-560	5.3	80	80	3	10	10	560	0
PDL30-90-D19	3.9	80	80	2	15	15	90	0
PDL30-150-D19	3.9	80	80	2	15	15	150	0
PDL30-250-D19	3.9	80	80	2	15	15	250	0
PDL30-350-D19	3.9	80	80	2	15	15	350	0
PDL30-450-D19	3.9	80	80	2	15	15	450	0
PDL30-550-D19	3.9	80	80	2	15	15	550	0
PDL30-650-D19	3.9	80	80	2	15	15	650	0
PDL30-130-D20	3.9	80	80	2	15	15	130	0
PDL30-230-D20	3.9	80	80	2	15	15	230	0
PDL30-330-D20	3.9	80	80	2	15	15	330	0
PDL30-430-D20	3.9	80	80	2	15	15	430	0
PDL30-530-D20	3.9	80	80	2	15	15	530	0
PDL30-630-D20	3.9	80	80	2	15	15	630	0
PDL30-730-D20	3.9	80	80	2	15	15	730	0
PDL30-930-D20	3.9	80	80	2	15	15	930	0
PDL30-1130-D20	3.9	80	80	2	15	15	1130	0
PDL30-1330-D20	3.9	80	80	2	15	15	1330	0
PDL30-1450-D20	3.9	80	80	2	15	15	1450	0

Type	Max. speed [m/s]	Max. accel. [m/s ²]	Max. delay [m/s ²]	Std. speed [m/s]	Std. accel. [m/s ²]	Std. delay [m/s ²]	Max. pos. [mm]	Min. pos. [mm]
PDL40-170-D27	3	80	80	2	15	15	170	0
PDL40-230-D27	3	80	80	2	15	15	230	0
PDL40-320-D27	3	80	80	2	15	15	320	0
PDL40-440-D27	3	80	80	2	15	15	440	0
PDL40-530-D27	3	80	80	2	15	15	530	0
PDL40-70-D28	3	80	80	2	15	15	70	0
PDL40-160-D28	3	80	80	2	15	15	160	0
PDL40-280-D28	3	80	80	2	15	15	280	0
PDL40-370-D28	3	80	80	2	15	15	370	0
PDL40-460-D28	3	80	80	2	15	15	460	0
PDL40-580-D28	3	80	80	2	15	15	580	0
PDL40-670-D28	3	80	80	2	15	15	670	0
PDL40-880-D28	3	80	80	2	15	15	880	0
PDL40-1060-D28	3	80	80	2	15	15	1060	0
PDL40-1270-D28	3	80	80	2	15	15	1270	0
PDL40-1480-D28	3	80	80	2	15	15	1480	0
PDL40-1660-D28	3	80	80	2	15	15	1660	0
PDL40HP-0200-D27	2.1	80	80	1.5	15	15	200	0
PDL40HP-0320-D27	2.1	80	80	1.5	15	15	320	0
PDL40HP-0410-D27	2.1	80	80	1.5	15	15	410	0
PDL40HP-0160-D28	2.1	80	80	1.5	15	15	160	0
PDL40HP-0330-D28	2.1	80	80	1.5	15	15	330	0
PDL40HP-0460-D28	2.1	80	80	1.5	15	15	460	0
PDL40HP-0550-D28	2.1	80	80	1.5	15	15	550	0
PDL40HP-0760-D28	2.1	80	80	1.5	15	15	760	0
PDL40HP-0940-D28	2.1	80	80	1.5	15	15	940	0
PDL40HP-1150-D28	2.1	80	80	1.5	15	15	1150	0
PDL40HP-1360-D28	2.1	80	80	1.5	15	15	1360	0
PDL40HP-1540-D28	2.1	80	80	1.5	15	15	1540	0

6.4.2 Teaching the positions on electric axes

The following three options are available for teaching the positions on the electric axes:

1. Manual shifting



DANGER

Risk of injury due to electric shock!

When working on the electric axes, there is a danger of electric shock!

- With the C1xx0 controller, the safety inputs X33 must be safely disconnected, or the power supply unit (72 V) must be disconnected on the primary side!

Procedure for manual teaching:

1. Reference drive.
2. Push the axes into position by hand.
 - Logistics voltage **ON**, power motors **OFF**.
3. Read out values from the controller for transfer to the pick & place movement.
 - ⇒ Manual teaching is completed.

2. Teaching in jog mode

Procedure for manual teaching:

1. Reference drive.
2. Add or subtract value to the current position.
 - Can be programmed via relative command.
3. The existing module for absolute positioning can be converted into a module for relative positioning by changing a variable.
 - ⇒ Teaching in jog mode is completed.

3 Set up with reduced speed



Please observe the associated instructions for safely reduced speed (www.afag.com)!

6.4.3 Adjusting damping and speeds on pneumatic modules

NOTICE

Risk of damage to property!

Incorrectly set end-position damping can cause damage to the device or the periphery.

- Observe the notes and permissible values.

Setting the speeds on the pneumatic modules

Notes on the setting:

1. The speeds are usually set by the factory to the required cycle time.
2. The set speed can be changed via throttles at the exhaust air outlets on the control block.
3. If your handling system does not have a control block, the speed can also be regulated by exhaust air throttles.

NOTICE

Danger of material damage in case of incorrect valve actuation!

5/3 directional control valves must not be controlled as impulse valves, as the modules start up against an empty volume in case of low leakage. The module is damaged by the high speed and poor damping.

- Do not control the valves as impulse valves!

6.4.4 External position measuring system

A) Adjust the distance from the sensor to the belt

Notes on the setting:

1. Mount the sensor parallel to the belt using a feeler gauge.
 - Value for the distance between sensor and belt (see table).

Sensor type	Distance min.	Distance max.	Recommend
MSK1000	0.1mm	0.2mm	0.1mm
MSA501	0.1mm	1.5mm	0.5mm
MSA213	0.1 mm	0.8 mm	0.1 mm

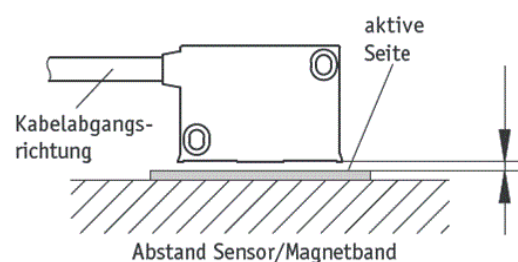

2. Adjust the distance between the sensor and the belt.
 - ⇒ The desired distance is set.

B) Setting the reference point MSK1000

Setting the reference point is necessary to prevent an index from being detected too early or too late when referencing the axis. This would result in a position shift according to the pole division of the band.

To set the reference point, the distance between the mechanical stop and the index on the magnetic tape must be set to the distance according to the following table:

Sensor type	Distance to be set	Distance min.	Distance max.	Pole division band
MSK1000	0.50mm	0.35mm	0.65	1mm

To set the distance between the mechanical stop and the index on the magnetic tape, proceed as follows:

1. Configure the system as described in the LinMot manual.
 - Set the Home Position to 0 mm.
2. Reference the axis.
3. De-energise the axis by removing the switch ON-bit.
4. Press the axle by hand against the mechanical stop.
5. Adjust the actual position by moving the sensor so that the distance to be set appears with a negative sign.
 - e.g. Home Position = 0 mm -> Actual Position = - 0.5 mm



If the home position is set to a different value, the corresponding offset must be taken into account for all masses:

- e.g. Home Position = 50 mm -> Actual Position = 49.5 mm

If the axis is set to positive Homeing, the distance must be added:

- e.g. Home Position = 500 mm -> Actual Position = 500.5 mm

6. Set new axis reference position.
7. Move the axle to the mechanical end stop so that the current is at maximum.
8. Check setting (e.g. -0.5 mm)
 - ⇒ The desired distance is set.

C) Switching distance



The reference sensor of the electrical axes is mounted with a feeler gauge at a distance of 0.1 mm parallel to the switching lug.

6.4.5 MSA 501 calibration (only for retrofitting and replacement)

1. Deenergize the controller:
 - Deenergize the controller to which the sensor you want to reset to zero is connected.
2. Disconnect the cable from the plug:
 - While the controller is deenergized, unscrew the cable of the position measuring system from the sensor.
3. Connect the calibration box to the voltage source:
 - Connect the USB connector of the calibration box to the PC or a 5 V power supply.
4. Connect the calibration box to the sensor:
 - Carefully screw the plug of the calibration box all the way onto the sensor – ensure that the anti-twist device in the plug is aligned properly.
5. Switch on the power:
 - Using the switch on the calibration box, switch on the power, and then wait at least 10 seconds.
6. Reset the sensor to zero:
 - Push the axis into its home position. Then, in order to reset the sensor to zero, either press and hold the button (green button on the calibration box) for at least 2 seconds or leave it switched on, and then switch it off again.
7. Switch off the power:
 - Using the switch on the calibration box, switch off the power.
8. Disconnect the connection to the calibration box:
 - Unplug the connector and the USB connection.
9. Connect the cable to the sensor:
 - While the system is deenergized, carefully screw the connector of the position measuring system all the way onto the sensor.
10. Switch on the power on the controller:
 - Switch on the power on the controller, and reference the axis once.

6.4.6 Wizard LinMot Talk MAS501 (only for retrofitting and replacement)

In the wizard, select the following settings under step 4/9:

Schritt 4/9: Externe Positionssensoren

Externer Positionssensor

Typ:

Zählrichtung:

Auflösung r (1/4 Periodenlänge): um

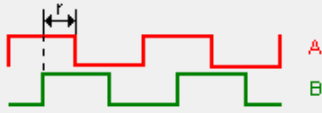

Mit einem zusätzlichen externen Positionsmesssystem lässt sich die Positioniergenauigkeit und die Linearität steigern. Das optionale Messsystem wird an Ext Pos Sens Stecker am Drive angeschlossen.

Mode:

Sensor Type:

Count Direction:

SSI Resolution: um

Reading Pulse Width: ns Reading Bits:

Position Decoding: Position Bits:

Die Position wird nach dem Startvorgang des Controllers wiederhergestellt. Das Wiederherstellen der Position sowie die Positionierung während des Betriebs erfolgen über einen externen Absolutwertgeber, welcher via SSI-Interface mit dem Controller verbunden ist. Der Motor kann auch im stromlosen Zustand bewegt werden, ohne dass die Position beim nächsten Hochfahren des Controllers verlorengeht. Eine einmalige Referenzfahrt ist jedoch erforderlich.

As is with axes without a measuring system, the homing method is to “home” all the way to the mechanical end stop.

Schritt 7/9: Homing I

Suchfahrt zur Home Position

Geschwindigkeit: m/s

Modus:

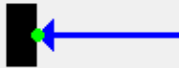

6.4.7 MSA213C calibration (only for retrofitting and replacement)

Use calibration box MAS213C!

Set the switch on the box to 0.

Plug both USB connectors of the box into the USB ports of the PCs/NBs.

Connect the pin connector to the sensor.



Start the program.

(For details regarding the program, refer to USB stick or contact our service department.)

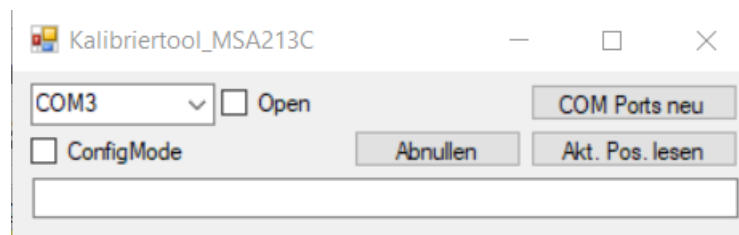

1. Select the COM port.
2. Check "open".
3. Check "ConfigMode".
4. Set the switch on the box to 1.
5. If a text appears in the text box and the "ConfigMode" is no longer checked, the sensor will be in Config mode (LED on the sensor will light up in white.)
6. Push the axis onto the negative stop (e.g. retracted on ES20/30.)
7. Press the "Reset to zero" button.
8. Use the "Read Act. Pos." button to read back the position.

Example: ES30-500EL

Retracted +00000100> = 0.1mm

Extended +00504879> = 504,879mm

Alternatively, open the terminal program:

(For program, refer to “Terminal” software, or contact our service department.)

Settings:

COM port: use an appropriate port
 Boud rate: 19200
 Data bits: 8
 Parity: none
 Stop bit: 1
 Handshake: none

Terminal v1.93b - 20141030B - by Br@y++

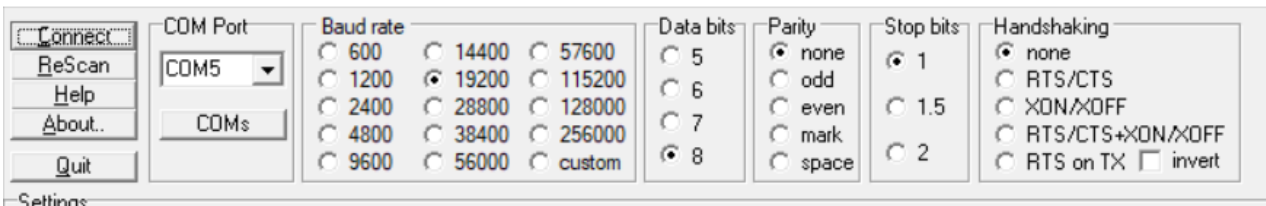

Press the “Connect” button to establish the connection.

Enter “s_conf” into the input line. Check “+CR.”

Set the switch on the calibration box to 1 while simultaneously pressing the “-> Send” button multiple times.

Terminal v1.93b - 20141030B - by Br@y++

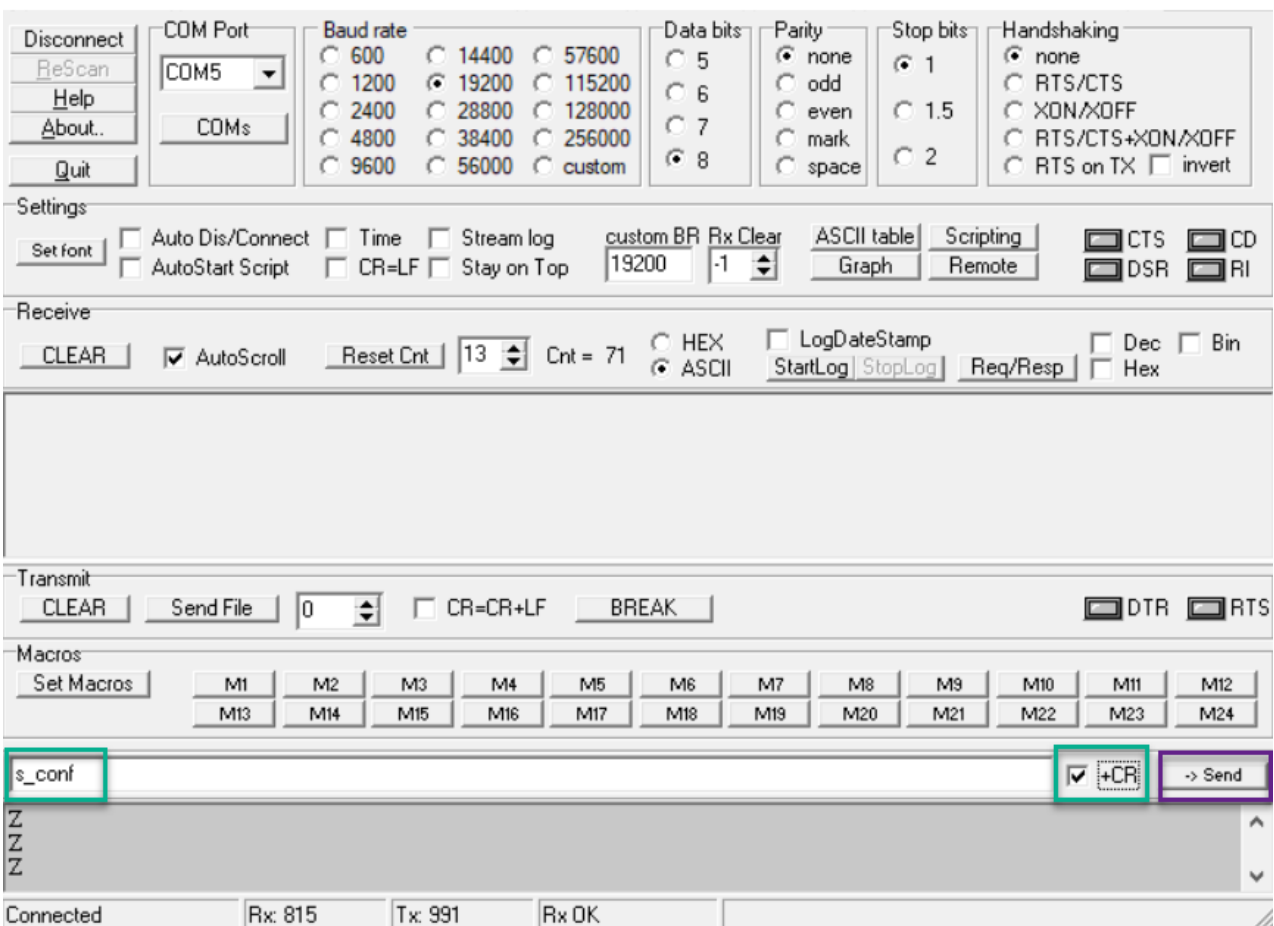

Commissioning

If everything worked properly, a few characters will be displayed in the start-up area, and the LED on the sensor will light up in white.

Terminal v1.93b - 20141030B - by Br@y++

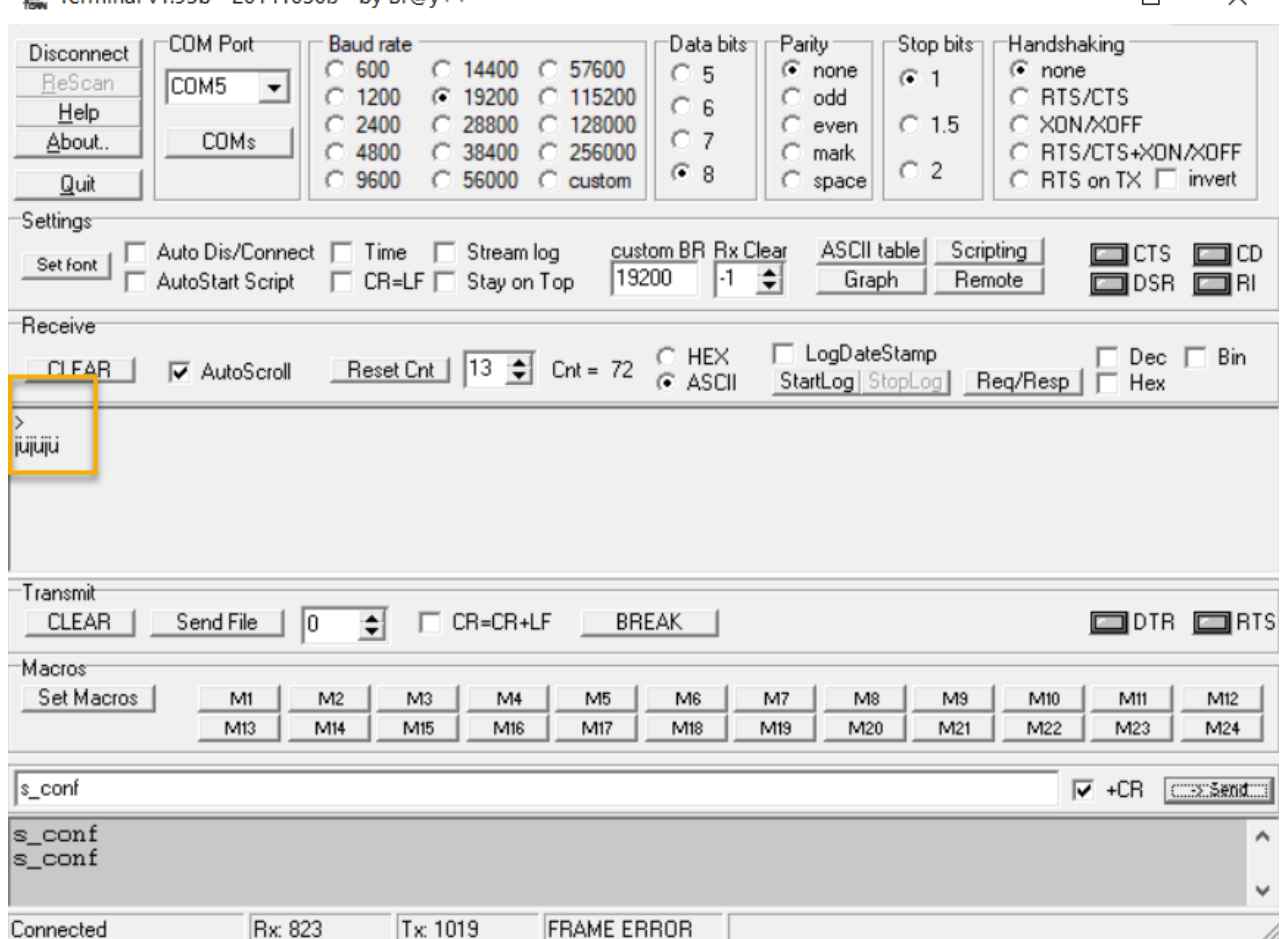

The screenshot shows a terminal application window with the following sections:

- COM Port:** COM5
- Baud rate:** 19200
- Data bits:** 8
- Parity:** none
- Stop bits:** 1
- Handshaking:** none
- Settings:**
 - Auto Dis/Connect:
 - Time:
 - Stream log:
 - custom BR: 19200
 - Rx Clear: -1
 - ASCII table:
 - Scripting:
 - CTS:
 - CD:
 - AutoStart Script:
 - CR=LF:
 - Stay on Top:
 - Graph:
 - Remote:
 - DSR:
 - RI:
- Receive:**
 - CLEAR:
 - AutoScroll:
 - Reset Cnt: 13
 - Cnt = 72
 - HEX:
 - ASCII:
 - LogDateStamp:
 - StartLog:
 - StopLog:
 - Req/Resp:
 - Dec:
 - Bin:
 - Hex:
- Transmit:**
 - CLEAR:
 - Send File:
 - 0
 - CR=CR+LF:
 - BREAK:
 - DTR:
 - RTS:
- Macros:**
 - Set Macros:
 - M1 to M24:
- Message:** s_conf
- Status:** Connected, Rx: 823, Tx: 1019, FRAME ERROR

Push the axis onto the negative stop (e.g. retracted on ES20/30.)

Enter command “G0000010000” in the input line. Remove the check from “+CR,” and press the “-> Send” button.

The sensor is reset to zero.



Read back the position with the “Z” command.

Example: ES30-500EL

Red box: Retracted module position

Purple box: Extended module position

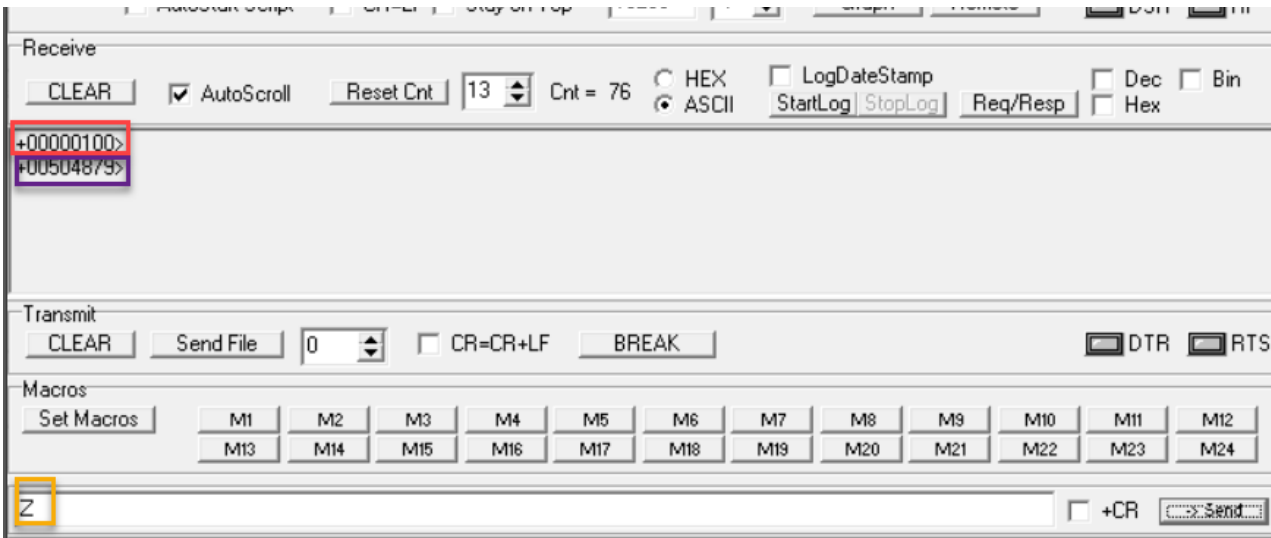

6.4.8 Wizard LinMot Talk MSA213C

Motor Wizard
— □ ×

Schritt 4/9: Externe Positionssensorik

Externer Positionssensor

Typ:

Zählrichtung:

Auflösung r (1/4 Periodenlänge): um



Mit einem zusätzlichen externen Positionsmesssystem lässt sich die Positioniergenauigkeit und die Linearität steigern. Das optionale Messsystem wird an Ext Pos Sens Stecker am Drive angeschlossen. Falls ein absoluter Positionssensor gewählt wird, wird auch die Position Recovery entsprechend gesetzt.

Mode:

Sensor Type:

Count Direction:

Resolution: um

Multiturn Position Bits: Position Bits:

CRC Bits: CRC Polynom (dec):

Die Position wird nach dem Startvorgang des Controllers wiederhergestellt. Das Wiederherstellen der Position sowie die Positionierung während des Betriebs erfolgen über einen externen Absolutwertgeber, welcher mit dem Controller verbunden ist. Der Motor kann auch im stromlosen Zustand bewegt werden, ohne dass die Position beim nächsten Hochfahren des Controllers verlorengeht. Eine einmalige Referenzfahrt ist jedoch erforderlich.

Abgeleitete Einstellungen	Wert	Kommentar

Hilfe
< Zurück
Weiter >
Fertigstellen
Abbrechen

6.4.9 External Absolute Position Measuring System Calibration Box

A calibration box is required when replacing or retrofitting the magnetic tape of the absolute position measuring system.

CALIBRATION BOX MSA501 50521485
 CALIBRATION BOX MSA213c 50614170

7 Fault elimination

7.1 Safety instructions for troubleshooting



DANGER

Danger! Risk of electric shock!

If work on electrical components is required, ensure that the work is carried out properly, failure to do so will cause serious or fatal injuries.

- Work on the machine's electrical equipment may only be performed by skilled electrician or trained personnel under the supervision of a skilled electrician in accordance with all relevant electrical regulations.



WARNING

Danger of injury due to faulty troubleshooting!

Poorly performed troubleshooting work can lead to serious injuries and damage to property.

- Only use trained specialist personnel for troubleshooting.
- All work on the modules must be carried out with the power supply cut off!



WARNING

Risk of injuries due to uncontrolled parts movements!

Signals from the control system can trigger unintentional movements of the EPS, which can cause injury.

- Before starting any work on the EPS, switch off the control unit and secure to prevent it from being switched on.
- Observe the operating instructions of the controller used!



Also observe the safety instructions in  chap. 2 „Safety instructions“ in this manual.

7.2 Fault causes and remedy



In the event of malfunctions that could affect safety, the system must be shut down **immediately** and secured against being switched on again.

The fault must then be eliminated immediately!

8 Maintenance and repair

8.1 General notes

The EPS system is almost maintenance-free. Nevertheless, some maintenance work must be carried out to ensure an optimum operating condition of the EPS.

EPS systems are high-performance devices with very short cycle times. The service life of the units depends mainly on the ambient conditions and maintenance.

It is therefore essential to follow the maintenance instructions for the individual modules!

8.2 Safety instructions for Maintenance and Repair

DANGER



Risk of injury due to electric shock!

If work on electrical components is required, ensure that the work is carried out properly, failure to do so will cause serious or fatal injuries.

- All work on the module must be carried out with the power supply cut off!
- Switch off the power supply and secure it against being switched on again.

DANGER



Risks by the pneumatic system!

If work on electrical components is required, ensure that the work is carried out properly, failure to do so will cause serious or fatal injuries.

- All work on the systems must be carried out with the power supply cut off!
- Switch off the compressed air supply and secure it against being switched on again.

WARNING



Danger of injury due to improper maintenance!

Improperly carried out maintenance activities can cause considerable damage to property and serious injury.

- Only use trained specialist personnel to carry out the activities.
- Always wear personal protective equipment when carrying out maintenance and repair work!



Also observe the safety instructions in  chap. 2 „Safety instructions“ in this manual.

8.3 Maintenance activities and maintenance intervals





- Observe the specified maintenance and care intervals. The intervals refer to a normal operating environment.
- If the system is to be operated in an environment with abrasive dusts or corrosive or aggressive vapours, gases or liquids, the approval of Afag must be obtained in advance.

8.3.1 Overview of the maintenance points



Fig. 27 Maintenance EPS systems (exemplary representation)

No.	Maintenance point	Maintenance work	Interval	System [On/Off]	Remarks
1.	EPS handling system	Cleaning and checking 	As required	[Off]	- <ul style="list-style-type: none"> ▪ Clean the servo gripper with a dry, lint-free cloth. - Do not spray the EPS with water, do not use aggressive cleaning agents. - Carry out a visual inspection of the EPS system.
2.	Pneumatic cylinder weight compensation (if installed)	Check	As required	[Off]	-
2.	Pneumatic cylinder				<ul style="list-style-type: none"> ▪ If a pneumatic cylinder is used as a weight compensation, check it for leakage once a year.

8.3.2 Further maintenance

Further maintenance is not required, if the ambient conditions listed below are complied with:

- Clean working area
- No use of splash water
- No abrasion or process dusts
- Environmental conditions as specified in the technical data

8.4 Spare parts

This section lists the spare parts of the standard components. For special assemblies, the order numbers on our delivery note apply.

8.4.1 Motor cable - Designation - Axes - Controller - Application

Designation			Module/axis									Servo control.		Application		
Manufacturer's designation	Afac designation		ES20	SE20	RA-40	PEL20	ES30	SE30	PxL30	PxL40	PxL40-HP	C1xxx	E12xx	Static installation	Dynam. installation	Robot installation
			K05-D/R-8	<->	Motor cable-M21-8m-0-0-X	x	x	x	x							
KS05-D/R-8	<->	Motor cable-M21-8m-0-0-1	x	x	x	x								x	X	
KR05-D/R-8	<->	Motor cable-M21-8m-0-0-2	x	x	x	x								x	x	X
K05-W/R-8	<->	Motor cable-M20-8m-0-2-X	x	x	x	x							x	X		
KS05-W/R-8	<->	Motor cable-M20-8m-0-2-1	x	x	x	x							x	x	X	
KR05-W/R-8	<->	Motor cable-M20-8m-0-2-2	x	x	x	x							x	x	x	X
K05-Y/R-8	<->	Motor cable-M16-8m-0-1-X	x	x	x	x						x		X		
KS05-Y/R-8	<->	Motor cable-M16-8m-0-1-1	x	x	x	x						x		x	X	
KR05-Y/R-8	<->	Motor cable-M16-8m-0-1-2	x	x	x	x						x		x	x	X
K15-W/C-8	<->	Motor cable-M24-8m-0-2-X					x	x	x	x	X		x	X		
KS10-W/C-8	<->	Motor cable-M22-8m-0-2-1					x	x	x	x	x		x	x	X	
KR10-W/C-8	<->	Motor cable-M22-8m-0-2-2					x	x	x	x	x		x	x	x	X
K15-Y/C-8	<->	Motor cable-M23-8m-0-1-X					x	x	x	x	x	x		X		
KS10-Y/C-8	<->	Motor cable-M17-8m-0-1-1					x	x	x	x	x	x		x	X	
KR10-Y/C-8	<->	Motor cable-M17-8m-0-1-2					x	x	x	x	x	x		x	x	X
KS05-R/R-8	<->	Motor cable extension-M16-8m-0-0-1	x	x	x	x						x	x	X	X	
KR05-R/R-8	<->	Motor cable extension-M16-8m-0-0-2	x	x	x	x						x	x	x	x	X
K15-C/C-8	<->	Motor cable extension-M23-8m-0-0-X					x	x	x	x	x	x	x	X		
KS10-C/C-8	<->	Motor cable extension-M17-8m-0-0-1					x	x	x	x	X	x	x	x	X	
KR10-C/C-8	<->	Motor cable extension-M17-8m-0-0-2					x	x	x	x	x	x	x	x	x	X

Note: X = preferred variant; x = application possible

8.4.2 Motor cable

Designation	Article no.
Motor cable-M16-4m-0-1-X	50463073
Motor cable-M16-6m-0-1-X	50463076
Motor cable-M16-8m-0-1-X	50463078
Motor cable-M16-4m-0-1-1	50437168
Motor cable-M16-6m-0-1-1	50437167
Motor cable-M16-8m-0-1-1	50427023
Extension-M16/M20-2m-0-0-1	50450944
Extension-M16/M20-4m-0-0-1	50427026
Extension-M16/M20-6m-0-0-1	50463082
Extension-M16/M20-2m-0-0-2	50463081
Motor cable-M17-4m-0-1-1	50437170
Motor cable-M17-6m-0-1-1	50437169
Motor cable-M17-8m-0-1-1	50427021
Extension-M17/M22/M23/M24-2m-0-0-1	50463084
Extension-M17/M22/M23/M24-4m-0-0-1	50427024
Extension-M17/M22/M23/M24-6m-0-0-1	50463087
Extension-M17/M22/M23/M24-2m-0-0-2	50463085
Extension-M17/M22/M23/M24-4m-0-0-2	50463086
Motor cable-M20-4m-0-2-X	50463088
Motor cable-M20-6m-0-2-X	50463090
Motor cable-M20-8m-0-2-X	50463092
Motor cable-M20-4m-0-2-1	50463089
Motor cable-M20-6m-0-2-1	50463091
Motor cable-M20-8m-0-2-1	50463093
Motor cable-M21-4m-0-0-X	50463094
Motor cable-M21-6m-0-0-X	50463096
Motor cable-M21-8m-0-0-X	50463098
Motor cable-M21-4m-0-0-1	50463095
Motor cable-M21-6m-0-0-1	50463097
Motor cable-M21-8m-0-0-1	50463099
Motor cable-M22-4m-0-2-1	50463100
Motor cable-M22-6m-0-2-1	50463101
Motor cable-M22-8m-0-2-1	50463103
Motor cable-M23-4m-0-1-X	50463104
Motor cable-M23-6m-0-1-X	50463105
Motor cable-M23-8m-0-1-X	50463106
Motor cable-M24-4m-0-2-X	50463107
Motor cable-M24-6m-0-2-X	50463108
Motor cable-M24-8m-0-2-X	50463109

8.4.3 Servo controller

Designation		Article no.
Controller E1250-EC	for EtherCAT	16080243
Controller E1250-PL	for PowerLink	50465787
Controller C1251-MI-XC-2S	Multinterface, untegrated Safety	50597007
Controller C1250-MI-XC-1S	Multinterface	50581667
Controller C1250-SE-XC-1S	For Sercos over EtherCAT	16080409
Controller C1250-SC-XC-1S	for Sercos III	16080417
Controller C1250-PN-XC-1S	for Profinet	16080415
Controller C1250-PL-XC-1S	for PowerLink	16080413
Controller C1250-PD-XC-1S	for Profidrivet	16080763
Controller C1250-LU-XC-1S	for LinUDP	16080741
Controller C1250-IP-XC-1S	for Ethernet IP	16080411
Controller C1250-EC-XC-1S	for EtherCat	16080405
Controller C1200-GP-XC-1S	for General Purpose	16080407
Controller C1150-SE-XC-1S	For Sercos over EtherCAT	16080768
Controller C1150-PN-XC-1S	for Profinet	16080429
Controller C1150-EC-XC-1S	for EtherCat	16080434
Controller C1100-GP-XC-1S	for CANopen	16080432

8.4.4 Position measuring system

Designation	Article no.
External position measuring system ES20 050mm	50427547
External position measuring system ES20 100mm	50427560
External position measuring system ES20 200mm	50427573
External position measuring system ES20 300mm	50427586
External position measuring system ES30 050mm	50429204
External position measuring system ES30 100mm	50429217
External position measuring system ES30 200mm	50429230
External position measuring system ES30 300mm	50429243
External position measuring system ES30 400mm	50429256
External position measuring system ES30 500mm	50429257
External position measuring system ES40 100mm	50470244
External position measuring system ES40 200mm	50470245
External position measuring system ES40 300mm	50470246
External position measuring system ES40 400mm	50470247
External position measuring system ES40 500mm	50470248
External position measuring system PEL20	50472112
External position measuring system PDL30/40	50472113
Encoder cable-G8-10m-0-0-1	50468310
Encoder cable-G18-10m-90-0-1	50468311
Extension-G18-2m-0-0-1	50468312

Extension-G18-5m-0-0-1	50468313
Encoder cable-G19-10m-0-0-1	50468314
Encoder cable-G19-10m-90-0-1	50468315

8.4.5 MagSpring

Designation		Article no.
MagSpring rotor ML01-12x130/80-10	Force 11N/40N for 50 mm stroke	50430383
MagSpring rotor ML01-12x130/80-15	Force 17N/50N for 50 mm stroke	50430384
MagSpring rotor ML01-12x130/80-20	Force 22N/60N for 50 mm stroke	50430385
MagSpring rotor ML01-12x210/160-10	Force 11N/40N for 100 mm stroke	50430386
MagSpring rotor ML01-12x210/160-15	Force 17N/50N for 100 mm stroke	50430387
MagSpring rotor ML01-12x210/160-20	Force 22N/60N for 100 mm stroke	50430388
MagSpring rotor ML01-12x290/240-10	Force 11N/40N for 200 mm stroke	50430389
MagSpring rotor ML01-12x290/240-15	Force 17N/50N for 200 mm stroke	50430390
MagSpring rotor ML01-12x290/240-20	Force 22N/60N for 200 mm stroke	50430391
MagSpring rotor ML01-12x370/320-10	Force 11N/40N for 300 mm stroke	50430392
MagSpring rotor ML01-12x370/320-15	Force 17N/50N for 300 mm stroke	50430393
MagSpring rotor ML01-12x370/320-20	Force 22N/60N for 300 mm stroke	50430395
MagSpring stator MS01-20x60/50	Force 11-22N for 50 mm stroke	50430374
MagSpring stator MS01-20x140/130	Force 11-22N for 100 mm stroke	50430375
MagSpring stator MS01-20x220/210	Force 11-22N for 200 mm stroke	50430376
MagSpring stator MS01-20x300/290	Force 11-22N for 300 mm stroke	50430378
MagSpring stator MS01-37x80/50	Force 40-60N for 50 mm stroke	50430379
MagSpring stator MS01-37x155/125	Force 40-60N for 100 mm stroke	50430380
MagSpring stator MS01-37x230/200	Force 40-60N for 200 mm stroke	50430381
MagSpring stator MS01-37x305/290	Force 40-60N for 300 mm stroke	50430382

9 Decommissioning and disposal

The EPS must be properly dismantled after use and disposed of in an environmentally friendly manner.

9.1 Safety instructions for decommissioning and disposal

WARNING



Risk of injury due to improper decommissioning and disposal!

Improperly carried out activities can result in considerable material damage and serious injury.

- Only use trained specialist personnel to carry out the activities.
 - Disconnect the media supply before dismantling the module!
 - Only remove the EPS system when the control unit is switched off and secured!
-

9.2 Decommissioning

If the EPS is not used for a longer period, it must be properly decommissioned and stored as described in [chapter 4.4](#).

9.3 Disposal

The EPS system must be disposed of properly at the end of their service life and the raw materials used must be recycled. Observe the legal regulations and company requirements.

The EPS system must not be disposed of as a complete unit. Dismantle the EPS system and separate the various components according to type of material and dispose of them properly: Information on proper disposal can be obtained from the responsible local authorities.

NOTICE

Risk to the environment due to incorrect disposal of the packaging material of the EPS!

Environmental damage can be caused by improper disposal of the EPS.

- Products that are predominantly made of metal (axles, modules, adapter plates, etc.) must be disposed of according to national law for metal recycling
 - Electronic products (regulators, controllers, etc.) must be disposed of in accordance with national legislation on electronic waste.
 - Electronic parts, electrical scrap, auxiliary and operating materials must be disposed of by approved specialist companies.
-

10 Declaration of incorporation

Declaration of incorporation

for partly completed machinery according to the Machinery Directive 2006/42/EC, Annex II, 1.B

The manufacturer hereby declares:

Afag Engineering GmbH, Gewerbestraße 11, DE-78739 Hardt

that the partly completed machine:

Product description	EPS systems
Type:	EPS mini YZ, EPS midi YZ, EPS maxi YZ, EPS giga YZ, EPS tera YZ, EPS mini XZ, EPS midi XZ, EPS maxi XZ, EPS mini XYZ, EPS midi XYZ, EPS maxi XYZ, EPS mini gantry XXYZ, EPS midi gantry XXYZ, EPS maxi gantry XXYZ, EPS mini gantry s, EPS midi gantry s, EPS maxi gantry s, EPS mini gantry h, EPS midi gantry h, EPS maxi gantry s

complies with the following essential health and safety requirements of the Machinery Directive 2006/42/EC at the time of declaration: 1.1.2, 1.1.3, 1.1.5, 1.3.2, 1.3.4 und 1.5.1.

Harmonised standards applied, in particular:	
2014/30/EU	Electromagnetic Compatibility Directive (EMC)
2014/35/EU	Low Voltage Directive (LVD)
EN ISO 12100:2010	Safety of machinery - General design principles - Risk assessment and risk reduction.
DIN EN 60204-1:2018	Safety of machinery - Electrical equipment of machines - Part 1: General requirements

Note: The partly completed machinery must not be put into service until the machinery into which it is to be incorporated has been declared in conformity with the provisions of Machinery Directive 2006/42/EC.

The manufacturer undertakes to transmit, in response to a reasoned request by the national authorities, relevant technical documentation for the partly completed machinery. The relevant technical documentation was created according to Annex VII, Part B of the above-mentioned Directive.

Authorised representative for compiling the technical documentation:

Dirk Roscher, Afag Engineering GmbH, Gewerbestraße 11, DE-78739 Hardt

Hardt, 17.01.2024

Adrian Fuchser



VP Afag

Klaus Bott



Director Engineering

Afag Automation AG
Luzernstrasse 32
6144 Zell
Switzerland
T +41 62 959 86 86
sales@afag.com

Afag GmbH
Wernher-von-Braun-Straße 1
92224 Amberg
Germany
T +49 9621 650 27-0
sales@afag.com

Afag Engineering GmbH
Gewerbestraße 11
78739 Hardt
Germany
T +49 7422 560 03-0
sales@afag.com

Afag Automation Americas
Schaeff Machinery & Services LLC.
883 Seven Oaks Blvd, Suite 800
Smyrna, TN 37167
USA
T +1 615 730 7515
nashville@afag.com

Afag Automation APAC
Afag Automation Technology (Shanghai) Co., Ltd.
Room 102, 1/F, Bldg. 56, City Of Elite
No.1000, Jinhai Road, Pudong New District
Shanghai, 201206
China
T +86 021 5895 8065
shanghai@afag.com