

Micro Motion® Model 4200 Transmitter

IECEX Zone 2/22 Installation Instructions

EPL Gc & EPL Dc



Subject:	Equipment type	Transmitter type 4200*****3A*****		
Manufactured and submitted for examination	Micro Motion, Inc.			
Address	7070 Winchester Circle Boulder, Co. 80301, USA			
Standard basis	IEC 60079-0:2017	General requirements		
	IEC-60079-15:2017	Non-Sparking		'n'
	IEC-60079-31:2013	Dust Enclosure		't'
Code for type of protection	Ex ec [ia Ga] IIC T6 Gc Ex tc [ia Da] IIIC T72°C Dc IP66/IP67			
Certificate of Conformity	IECEX SIR 19.0007 X			

THIS COMPONENT MUST COMPLY WITH REGULATORY AGENCY REQUIREMENTS. NO CHANGES ARE ALLOWED WITHOUT PRIOR AUTHORIZATION FROM MICRO MOTION APPROVALS ENGINEERING

Model Designation

1) Transmitter type 4200 * * * * 3A * * * * *

Instead of the * * * in the complete denomination letters and numerals will be inserted which characterize the following variations:

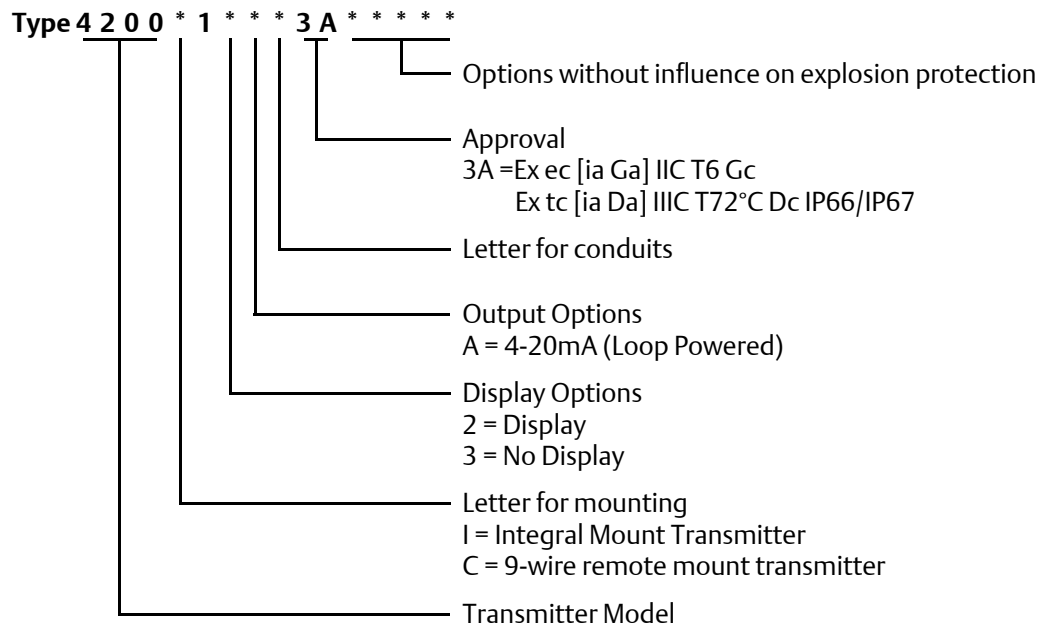

2) Description

- The transmitter is, in combination with a sensor, used for measurement of mass flow and data transmission.
- The electrical circuitry of the transmitters is mounted inside a metal enclosure which is divided into three compartments.
- The terminal compartment is equipped with terminals for the connection of I/O signals and power.
- The enclosure can be constructed with a terminal compartment for the connection of remotely operating non-sparking “nA, nC” safe sensors (type 4200C***3A****).
- Alternatively, the enclosure can be mounted directly to the sensor via a transition compartment (type 4200I***3A****). This type of mounting has to be certified separately.
- The transmitter is intended to be used in a hazardous dust environment without change to any of the electronics aspects of the design.

3) Parameters

3.1 I/O circuits:

3.1.1	for type 4200*****3A***** (J2, terminal 1 - 4)				
	nom. voltage		DC	30	V
	max. voltage	Um		250	V

3.2 Sensor circuits for type 4200*****3A*****:

3.2.1	Drive circuit; (J2 in J-box, DR+ BRN; DR- RED)				
	voltage	Uo	DC	6,51	V
	current; steady state	Io		136	mA

3.2.2	Pick-off circuits (J1 in J-box, LPO+ GRN; LPO- WHT; RPO+ BLU; RPO- GRY)				
	voltage	Uo	DC	6,51	V
	current	Io		2,63	mA

3.2.3	Temperature circuit (J1 in J-box, RTD+ VIO; RTD- ORA; RTD-SIG YEL)				
	voltage	Uo	DC	6,51	V
	current	Io		12,3	mA

3.3 Ambient temperature range

Type 4200*1*****	Ta				-40°C to +65°C
------------------	----	--	--	--	----------------

4) Marking

type	type of protection
4200*****3A*****	Ex ec [ia Ga] IIC T6 Gc Ex tc [ia Da] IIIC T72°C Dc IP66/IP67

5) Special conditions for safe use / Installation instructions

- 5.1 For hazardous area installations, refer to IEC 60079-14 or other required national standards.
- 5.2 The enclosure is manufactured from Aluminum, magnesium, titanium or zirconium may be used at the accessible surface of the equipment. In rare cases, ignition sources due to impact and friction sparks could occur. This shall be considered when the transmitter is being installed in Zone 0 locations for group II/III level of protection Ga/Da.
- 5.3 If a charge-generating mechanism is present, the exposed painted metallic part on the enclosure is capable of storing a level of electrostatic charge that could become incendive for IIC dust. Therefore, the user/installer shall implement precautions to prevent the build-up of electrostatic charge, e.g. earthing the metallic part. This is particularly important if the equipment is installed in a zone 0 location. Cleaning of the painted surface shall only be done with a damp cloth.
- 5.4 For the application of the transmitter in an ambient temperature of less than -20°C suitable cable and cable entries or conduit entries certified for this condition shall be used.
- 5.5 Enclosure entries can be used for double compression Ex-d IIC Gb/Ex tb IIC Db cable glands such as but not limited to Hawke 501/453 intended for use with effective filled and circular armored or braided cable; volume of the Ex-d enclosure is less than 2 liters
- 5.6 If certified conduit entries are used for the connection of the transmitter enclosure, the associated stopping boxes shall be installed immediately at the enclosure.
- 5.7 To maintain IP Rating of the Transmitter all cable entries, blanking elements or thread adapters must be rated IP66/IP67 minimum.
- 5.8 The window covers forms one unit and cannot be taken apart without destroying the cover parts. If a cover is damaged it must be replaced by a new cover.
- 5.9 The dimensions of the flameproof joints are in parts other than the relevant minimum or maximum values of IEC 60079-1:2014. For information on the dimensions of the flameproof joints contact the manufacturer.
- 5.10 The Flameproof joints are not intended to be repaired.
- 5.11 For model 4200*1*****: wiring to the Ex-e terminals shall be in compliance with the applicable Ex-e installation instructions attached below:



1809694.pdf

- 5.12 For J2 Screw terminal connections 1-4:
 - Conductors: Solid or Stranded
 - Wire Strip Length: 0.28" (7mm)
 - Screw Torque: 0.37 - 0.44 lb ft (0.5 - 0.6 Nm)
 - One wire: 26 - 14 AWG (0.129 - 2.08 mm²)
 - Two wires: 26 - 17 AWG (0.129 - 1.04 mm²)
- 5.13 Per IEC 61010 clause 5.4.2d:
 - 5.13.1 Pollution degree 4;
 - 5.13.2 Installation category I;
 - 5.13.3 Altitude 6562 feet (2000m);
 - 5.13.4 The humidity limits are 5 to 95% relative humidity, non-condensing between -40°F (-40°C) to +149°F (+65°C);
 - 5.13.5 Electrical supply 30V (Loop powered)
 - 5.13.6 Suitable for use outdoors within the limits and rating described herein
 - 5.13.7 Temperature Range -40°F (-40°C) to +149°F (+65°C);
 - 5.13.8 Supply voltage fluctuations are not to exceed ± 10 % of the nominal supply voltage
 - 5.13.9 Use of this equipment in a manner not specified by the manufacturer, the protection provided by equipment may be impaired.

Emerson Automation Solutions

Micro Motion Inc. USA
Worldwide Headquarters
7070 Winchester Circle
Boulder, Colorado 80301
T +1 303-527-5200
T +1 800-522-6277
F +1 303-530-8459
www.micromotion.com

Emerson Automation Solutions

Micro Motion Europe
Neonstraat 1
6718 WX Ede
The Netherlands
T +31 (0) 318 495 555
F +31 (0) 318 495 556
www.micromotion.nl

Emerson Automation Solutions

Micro Motion Asia
1 Pandan Crescent
Singapore 128461
Republic of Singapore
T +65 6777-8211
F +65 6770-8003

Emerson Automation Solutions

Micro Motion Romania
Str. Emerson Nr. 4
Cluj-Napoca 400641 Romania
T +40 364731012
F +40 364 731099

Emerson Automation Solutions

Micro Motion Japan
1-2-5, Higashi Shinagawa
Shinagawa-ku
Tokyo 140-0002 Japan
T +81 3 5769-6803
F +81 3 5769-6844

©2019 Micro Motion, Inc. All rights reserved.

The Emerson logo is a trademark and service mark of Emerson Electric Co. Micro Motion, ELITE, ProLink, MVD and MVD Direct Connect marks are marks of one of the Emerson Process Management family of companies. All other marks are property of their respective owners.

MICRO MOTION™

