

March 2009

Type S402Y Pressure Reducing Regulator



WARNING

Failure to follow these instructions or to properly install and maintain this equipment could result in an explosion, fire and/or chemical contamination causing property damage and personal injury or death.

Fisher® regulators must be installed, operated, and maintained in accordance with federal, state, and local codes, rules and regulations, and manufacturer's instructions.

If the regulator vents gas or a leak develops in the system, service to the unit may be required. Failure to correct trouble could result in a hazardous condition.

Call a gas service person to service the unit. Only a qualified person must install or service the regulator.

Introduction

This installation manual covers the installation and startup procedures for Type S402Y pressure reducing regulators.

The Type S402Y is typically used in residential or small commercial applications to reduce gas distribution pressures down to a reduced pressure range from 4.5-inches w.c. to 2.5 psig (11,0 mbar to 0,17 bar). The Type S402Y has an integral high capacity internal relief valve.

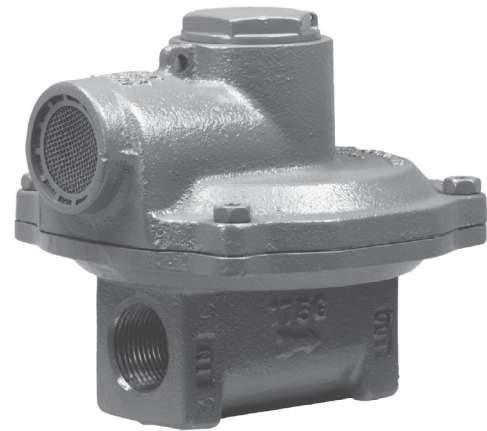

Figure 1. Type S402Y Pressure Reducing Regulator Assembly

Scope of the Manual

This instruction manual provides information on installation, maintenance, and replacement parts for Type S402Y pressure-reduction regulators.

Product Description

The Type S402Y is generally employed in residential or small commercial applications in order to reduce gas distribution pressures to a specified pressure range from 4.5-inches w.c. to 2.5 psig (11,0 mbar to 0,17 bar). The Type S402Y has an integral high capacity internal relief valve.

Specifications

Specifications for Type S402Y construction are found on page 2. The following information is stamped on the regulator at the factory: Type number, orifice size, spring range, and date of manufacture.



Type S402Y

Specifications

<p>Body Size and End Connection Styles⁽¹⁾ NPS 3/4 or 1, NPT</p> <p>Maximum Operating Inlet Pressure⁽²⁾ 125 psig (8,6 bar)</p> <p>Maximum Allowable Emergency Inlet Pressure⁽²⁾ 175 psig (12,1 bar)</p> <p>Allowable Outlet Pressures (Casing)⁽²⁾ Emergency: 10 psig (0,69 bar) Maximum Operating to Avoid Internal Part Damage: 5 psig (0,35 bar)</p> <p>Outlet Pressure Ranges⁽²⁾ See Table 2</p> <p>Orifice Sizes See Table 1</p>	<p>Temperature Capabilities⁽²⁾ -20° to 160°F (-29° to 71°C)</p> <p>Pressure Registration Internal</p> <p>Spring Case Vent Connection 1 NPT with removable screen (standard) 3/4 NPT with removable screen (optional)</p> <p>Spring Case Vent and Body Mounting Positions See Figure 5</p> <p>External Dimensions See Figure 6</p> <p>Approximate Weight 4 pounds (2 kg)</p>
--	---

- End connections threaded to other than ASME standards can usually be supplied.
- The pressure/temperature limits in this Instruction Manual and any applicable standard or code limitation should not be exceeded.

Table 1. Orifice Sizes and C_g Coefficients

ORIFICE SIZE		ORIFICE COLOR CODE	WIDE-OPEN C_g FOR RELIEF SIZING	MAXIMUM OPERATING PRESSURE FOR OPTIMUM PERFORMANCE ⁽¹⁾	
Inches	mm			Psig	bar
1/8	3,2	Blue	12.5	125	8,6
3/16	4,8	Green	28.2	80	5,5
1/4	6,4	Brown	50.0	60	4,1

1. Maximum operating inlet pressure is 125 psig (8,6 bar) for all orifice sizes. The optimum performance is based on 2-inches w.c (5 mbar) boost or 1-inch w.c. (2 mbar) droop.

Table 2. Outlet Pressure Ranges and Control Spring Data

OUTLET PRESSURE RANGES	CONTROL SPRING DATA			
	Part Number	Color	Wire Diameter, Inches (mm)	Free length, Inches (mm)
4.5 to 6-inches w.c. (11 to 15 mbar)	T13539T0012	Red	0.070 (1,78)	2.50 (63,5)
5.5 to 8-inches w.c. (14 to 20 mbar)	T13527T0012	Yellow	0.067 (1,70)	2.59 (65,8)
7.5 to 9.5-inches w.c. (19 to 24 mbar)	T13563T0012	Olive drab	0.067 (1,70)	3.24 (82,3)
9.5 to 13-inches w.c. (24 to 32 mbar)	T13529T0012	Green	0.075 (1,91)	3.00 (76,2)
13-inches w.c. to 1.5 psig (32 mbar to 0,10 bar)	T13564T0012	Unpainted	0.120 (3,05)	1.93 (49,0)
1.5 to 2.5 psig (0,10 to 0,17 bar)	T13536T0012	Blue	0.120 (3,05)	2.60 (66,0)

Principle of Operation

Inlet pressure flows through the open orifice around the valve disk and disk holder, around the cam stem down the remaining length of the orifice tube and into the outlet of the regulator body. However, not all of the pressure passes directly from the inlet to the outlet of the regulator. Pressure is channelled through openings in the orifice tube and pressurizes the cavity formed by the body and diaphragm/diaphragm head/cam stem

assembly. When downstream demand is reduced, the pressure under the diaphragm increases. This pressure overcomes the regulator setting (which is set by a spring) and moves the diaphragm assembly upwards. This upward motion is transferred to the cam stem which in turn bears against the sliding contact point on the back side of the disk holder.

The inclined surface of the cam then forces the disk holder toward the orifice and reduces gas flow. If a higher

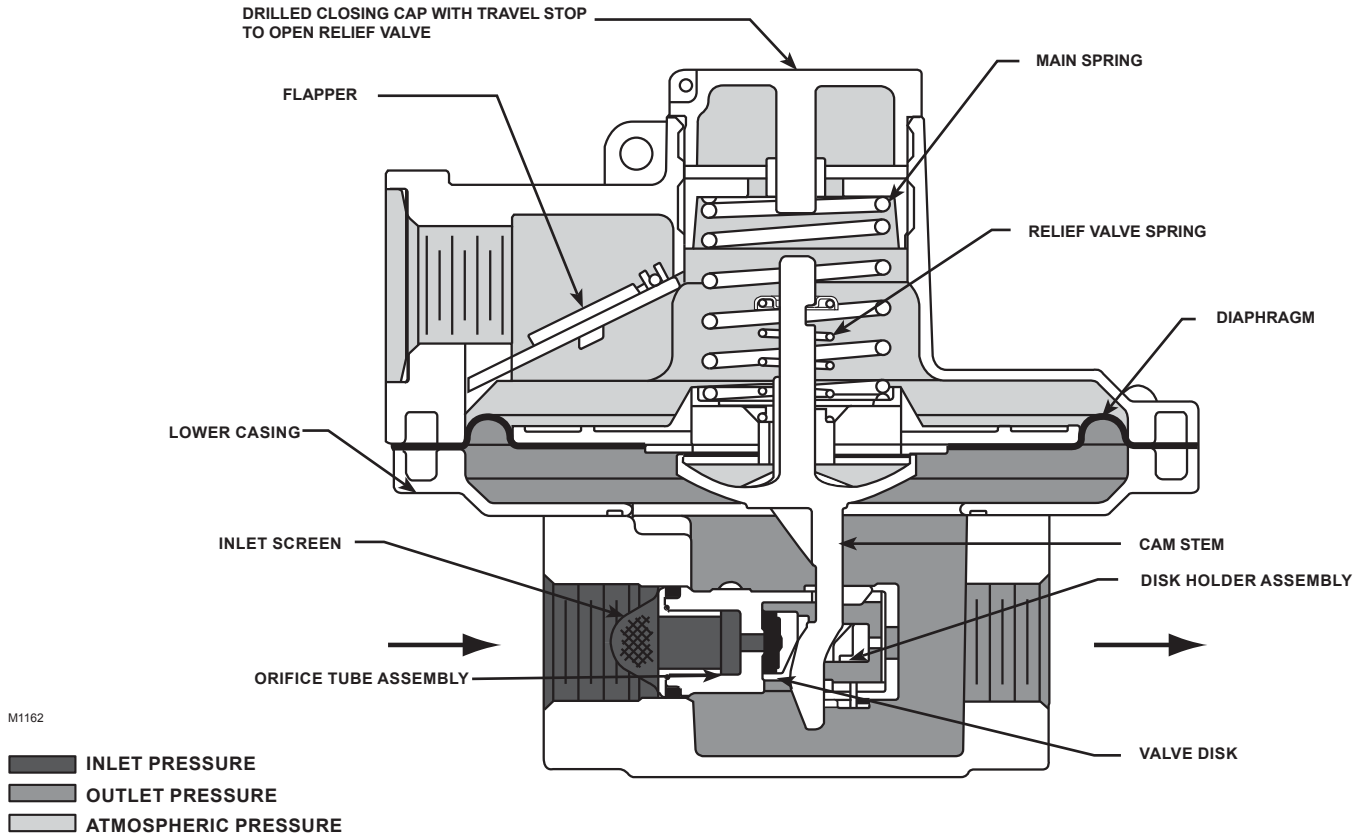

Figure 2. Type S402Y Operational Schematic

volume flow rate is demanded downstream, the pressure under the diaphragm decreases. The control spring force pushes the diaphragm/diaphragm head/cam stem assembly downward and the valve disk moves away from the orifice.

At the lockup (complete shutoff) position the ratio of the diaphragm travel to disk travel is 4 to 1 giving the regulator an effective 4 to 1 lever ratio for positive lockup. The cam stem is characterized for higher downstream demand to produce a mechanical boost effect.

Type S402Y regulator includes an internal relief valve for overpressure protection. If the downstream pressure exceeds the regulator setting and the regulator is not able to achieve complete shutoff (lockup) due to foreign matter lodged between the orifice and the valve disk or a failure in the valve disk, the regulator diaphragm assembly moves upwards trying to push the valve disk against the orifice. The valve disk and disk holder being pressed against the orifice will prevent the cam stem from being able to travel any further upward in conjunction with the diaphragm assembly. The continued leakage of the inlet pressure into the regulator cavity will then force the diaphragm and diaphragm head up off of the seating area of the relief valve overcoming

the relief valve spring which was pressing them together. The resulting gap will allow pressure to exit the regulator cavity and exhaust through the openings in the diaphragm head and out the spring case vent to atmosphere.

Installation

WARNING

Personal injury, equipment damage, or leakage due to escaping accumulated gas or bursting of pressure-containing parts may result if this regulator is overpressured or is installed where service conditions could exceed the limits given in Specification Section. To avoid such injury or damage, provide pressure-relieving or pressure-limiting devices (as required by Title 49, Part 192, of the U.S. Code of Federal Regulations, by the National Fuel Gas Code Title 54 of the National Fire Codes of the National Fire Protection Association, or by other

Type S402Y

applicable codes) to prevent service conditions from exceeding those limits.

Additionally, physical damage to the regulator could result in personal injury or property damage due to escaping gas.

To avoid such injury and damage, install the regulator in a safe location.

1. Only personnel qualified through training and experience should install, operate, and maintain a regulator. Before installing a Type S402Y regulator, check for damage which have might occurred in shipment. Also check for dirt or foreign materials which may have accumulated in the regulator body or in the pipeline.
2. The Type S402Y may be installed in any position (vertical or horizontal). Apply a good grade of pipe compound to the male threads (being sure not to apply pipe compound to flow path of the pipe) of the pipe and install the regulator so the flows is in the direction of the arrow cast on the body. Use approved piping procedures when installing the regulator. The spring case can be rotated to any position relative to the body.



WARNING

A regulator may vent some gas to the atmosphere. In hazardous or flammable gas service, vented gas may accumulate, and cause personal injury, death, or property damage due to fire or explosion. Vent a regulator in hazardous gas service to a remote, safe location away from air intakes or any hazardous location. The vent line or stack opening must be protected against condensation or clogging.

Under enclosed conditions or indoors, escaping gas may accumulate and be an explosion hazard. In these cases, the Type S402Y vent should be piped away from the regulator to a safe location outdoors.

3. On outdoors installations, regulators installed with vents in positions other than vertically down

require additional vent protection from the elements. Such protection may be with separate hood, shields, or the Fisher® Y602 Series vents.

4. Regulator operation within the ratings does not preclude the possibility of damage from the debris in the lines or from external sources. A regulator should be inspected for damage periodically and after any overpressure condition.
5. With proper installation completed, slowly open the upstream and downstream shutoff valves. Check all connections for leaks. Check the downstream equipment for proper operation.
6. If outlet pressure adjustment is necessary, monitor downstream pressure with a gauge during the adjustment procedure. To increase the outlet pressure, the adjusting screw (key 12, Figure 1) must be turned clockwise. This requires removal of the closing cap (key 11, Figure 1). To reduce the outlet pressure setting, turn the adjusting screw counter-clockwise. Do not adjust the spring to procedure an outlet pressure setting above the limit stamped on the regulator.

Overpressure Protection

The wide-open C_g for relief sizing along with the capacity information should be used in choosing appropriate overpressure protection devices to ensure that none of the limits in the Specifications section, Table 1, or Table 2 are exceeded.

Overpressuring any portion of a regulator or associated equipment may cause leakage, parts damage, or personal injury due to bursting of pressure-containing parts or explosion of accumulated gas. Regulator operation within ratings does not prevent the possibility of damage from external sources or from debris in the pipeline. A regulator should be inspected for damage after any overpressure condition.

Startup



WARNING

In order to avoid an overpressure condition and possible equipment damage, pressure gauges should always be used to monitor pressures during startup.

1. Check to see that all downstream equipment is turned off.
2. Slowly open the upstream shutoff valve.
3. Slowly open the downstream shutoff valve.
4. Check all connections for leaks.
5. Light the downstream equipment pilot lights if applicable.

Adjustment

If set pressure adjustment is necessary, monitor downstream pressure with a gauge during the adjustment procedure. To increase the outlet pressure, the adjusting screw (key 12) must be turned clockwise. This requires removal of the closing cap (key 11). To reduce the outlet pressure setting, turn the adjusting screw counterclockwise. Do not adjust the spring to produce an outlet pressure setting above the limit stamped on the regulator.

The range of allowable pressure settings is stamped on the regulator. If a pressure setting beyond this range is necessary, substitute the appropriate regulator control spring. When changing the spring, also change the range stamped on the regulator to indicate the actual pressure range of the spring in use.

Before increasing the setting, refer to Table 1. Review the pressure limits for the control spring range being used and be certain that the new pressure setting will not result in an overpressure condition. After the spring adjustment has been completed, replace the closing cap.

Shutdown

Installation arrangements may vary, but in any installation it is important that the shutoff valves be opened or closed slowly and that the outlet pressure be vented before venting inlet pressure to prevent damage caused by reverse pressurization of the regulator. The steps below apply to the typical installation as indicated.

1. Slowly close the upstream shutoff valve.
2. Release downstream pressure and be sure the upstream pressure has been exhausted.

Maintenance



WARNING

To avoid personal injury or equipment damage from sudden release of pressure or uncontrolled gas, do not attempt any maintenance or disassembly without first isolating the regulator from system pressure and relieving all internal pressure as described in the shutdown procedure.

Regulators that have been disassembled for repair must be tested for proper operation before being returned to service. Due to the care Fisher takes in meeting all manufacturing requirements (heat treating, dimensional tolerances, etc.), use only replacement parts manufactured or furnished by Fisher to repair Fisher® regulators. Relight pilot lights according to normal startup procedures.

Due to normal wear or damage that may occur from external sources, this regulator should be inspected and maintained periodically. The frequency of inspection and replacement of parts depends upon the severity of service conditions or the requirements of local, state, and federal rules and regulations.

A program of periodic regulator inspection should be established. Visually inspect the regulator for:

1. Improper installation.
2. Plugged or frozen vent.
3. Wrong regulator in the system.
4. Internal or external corrosion.
5. Age of the regulator.
6. Any other condition that could cause the uncontrolled escape of gas.

Failure to establish an inspection program, as outlined above, could result in personal injury or property damage.

Type S402Y

Make sure the regulator vent, vent assembly, or vent pipe does not become plugged by mud, insects, ice, snow, paint, or etc. The vent screen aids in keeping the vent from becoming plugged, and the screen should be clean and properly installed.

Replace any regulators that have had water in their spring case and/or show evidence of external or internal corrosion. Checking for internal corrosion may require complete removal of the adjusting screw and shutdown of the gas system.

Older regulators are more likely to fail because of worn, damaged or corroded parts. Periodic repair of the diaphragm assembly, orifice tube assembly, and other parts subject to wear and/or corrosion; or a systematic replacement program should be based on the regulator's performance, the service area's environment, installation practices, and historical experience.

The following procedures are for complete regulator disassembly and assembly. All pressure must be released from the regulator before the following steps can be performed. While using the maintenance procedures, refer to Figure 3 for key number locations.

Note

The regulator may remain in the pipeline during maintenance procedures unless the body (key 1) is replaced or removed for repairs.

Control Spring or Diaphragm Assembly Replacement

1. Remove the closing cap (key 11) and turn the adjusting screw (key 12) counterclockwise until all compression is removed from the control spring (key 6).
2. If changing the control spring (key 6) is the only maintenance required, remove and replace the control spring.
3. To replace or reposition the spring case, remove the spring case screws (key 13) and lift off the spring case assembly (key 3).
4. For diaphragm maintenance, remove the diaphragm assembly **by tilting it toward the outlet** so that the cam stem may be pulled up and out of the orifice tube assembly (key 7).

5. Reassemble in the reverse order of the above procedures. Place the diaphragm assembly into position in the lower casing, being sure the cam stem (key 10) is properly inserted into the orifice tube assembly (key 7). Note that the diaphragm plate is marked with "Inlet" and "Outlet". Install the spring case assembly (key 3) and using a crisscross pattern, tighten the spring case screws (key 13).

Orifice Tube Assembly Replacement

1. Remove the spring case screws (key 13) which hold the lower casing to the body (key 1).

Note

When the actuator assembly is separated from the body, do not rotate the diaphragm/relief valve assembly without removing the spring case screws (key 13). The assembly incorporates an anti-rotation design, any rotational movement will damage the cam stem/diaphragm assembly.

2. Remove the diaphragm/relief valve assembly (key 10) by tilting it toward the outlet so that the cam stem slides up and out of the orifice tube assembly (key 7).
3. Remove the orifice tube screws (key 9) and then the orifice tube assembly (key 7).
4. Reassemble in the reverse order of the above procedure. Be sure to use a new orifice tube O-ring (key 8), body with O-ring lubricant.
5. Tighten the spring case screws (key 13) to 80-inch-pounds (9.0 N•m) of torque.
6. If necessary, refer to the installation and/or the startup and adjustment procedures.

Parts Ordering

When corresponding with your local Sales Office about this equipment, always reference the Type number that can be found stamped on the regulator.

When ordering replacement parts, reference the key number of each needed part as found in the following parts list. Separate kits containing all recommended spare parts are available. If construction changes are made in the field, be sure that the information on the regulator is also changed to reflect the most recent construction.

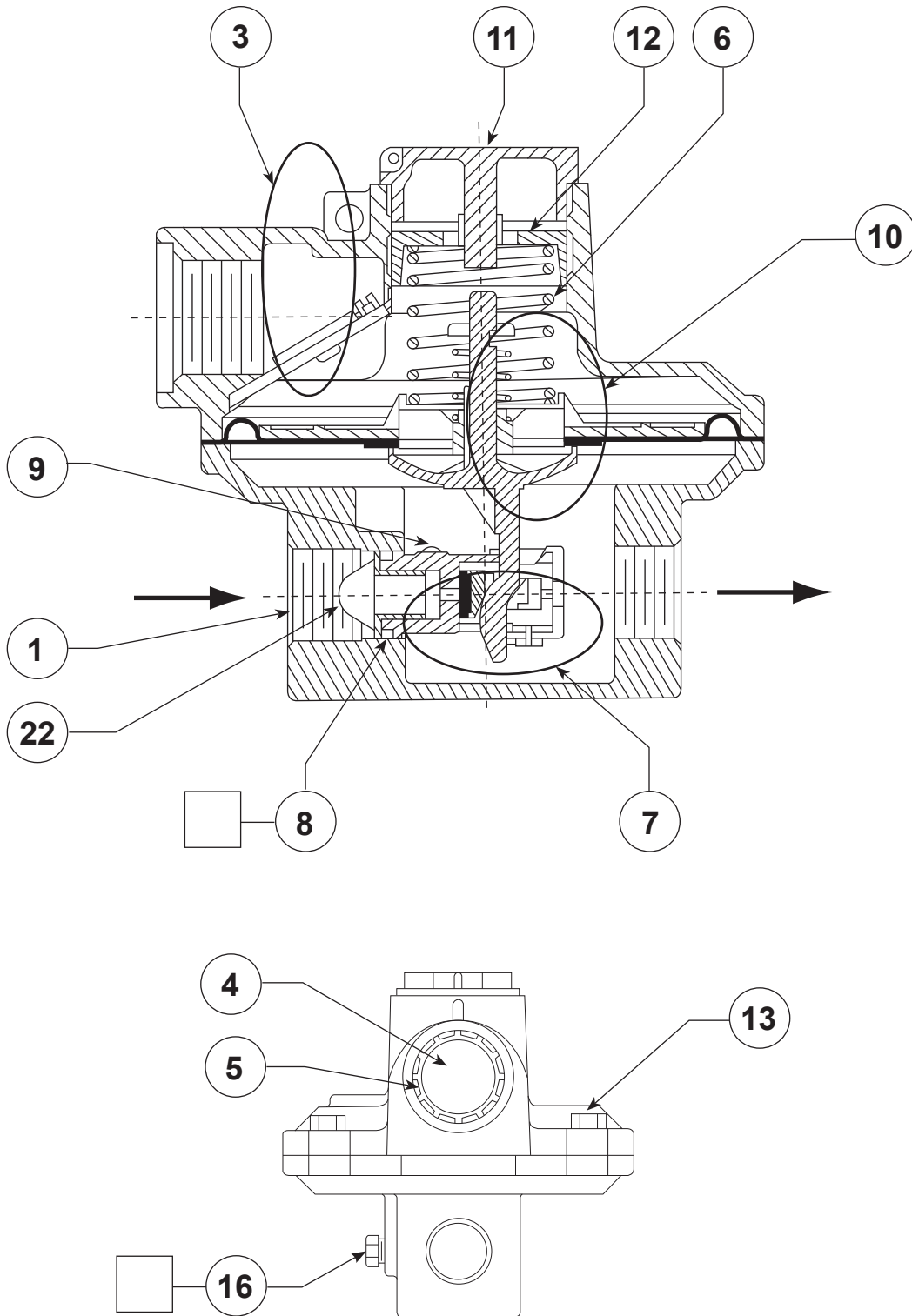

□ - Apply Lub / Sealant

T80288

Figure 3. Type S402Y Pressure Reducing Regulator Assembly

Type S402Y

Parts List

Key	Description	Part Number	Key	Description	Part Number
1	Body, Cast Iron No Gauge Tap NPS 3/4, NPT NPS 1, NPT Outlet Gauge Tap NPS 3/4, NPT NPS 1, NPT	T80281T0012 T80282T0012 T13649T0012 T13649T0022	7	Orifice Tube Assembly 1/8-inch 3/16-inch 1/4-inch	T13651T0012 T13651T0012 T13651T0112 T13651T0032
3	Spring Case Assembly For 1 NPT vent For 3/4 NPT vent	T20932T0012 T20932T0032	8*	Orifice Tube, O-Ring, Nitrile (NBR)	18B3438X012
4	Screen-Vent, 18-8 Stainless Steel	T1121338982	9	Orifice Tube Screw, Steel	T13526T0012
5	Retaining Ring, Zinc-plated Steel	T1120925072	10	Diaphragm/Relief Valve Assembly Relief Valve Spring Color	
6	Control spring 4.5 to 6-inches w.c. (11 to 15 mbar), 302 SST 5.5 to 8-inches w.c. (14 to 20 mbar), Zinc-plated steel 7.5 to 9.5-inches w.c. (19 to 24 mbar), Zinc-plated steel 9.5 to 13-inches w.c. (24 to 32 mbar), Zinc-plated steel 13-inches w.c. to 1.5 psig (0,03 to 0,10 bar), 302 SST 1.5 to 2.5 psig (0,10 to 0,17 bar), Steel	T13539T0012 T13527T0012 T13563T0012 T13529T0012 T13564T0012 T13536T0012	11	Closing Cap, ASA 309, Gray	T13524T0062
			12	Adjusting Screw 4.5 to 6-inches w.c. (11 to 15 mbar), Delrin® 5.5 to 8-inches w.c. (14 to 20 mbar), Delrin 7.5 to 9.5-inches w.c. (19 to 24 mbar), Delrin 9.5 to 13-inches w.c. (24 to 32 mbar), Delrin 13-inches w.c. to 1.5 psig (32 mbar to 0,10 bar), Zinc 1.5 to 2.5 psig (0,10 to 0,17 bar), Zinc	T13523T0012 T13523T0012 T13523T0012 T13523T0012 1B537944012 1B537944012
			13	Machinist Screw, Steel (4 required)	T13646T0012
			16	Pipe Plug, 304 Stainless Steel	1E823135042
			22	Screen, 18-8 Stainless steel For 3/4 NPT vent For 1 NPT vent	T13643T0012 T13644T0012
			23*	Gasket, Neoprene (CR) (not shown)	1P753306992

*Recommended spare part.
Delrin® is a mark owned by E. I. du Pont de Nemours and Co.

Industrial Regulators

Emerson Process Management Regulator Technologies, Inc.

USA - Headquarters
McKinney, Texas 75069-1872 USA
Tel: 1-800-558-5853
Outside U.S. 1-972-548-3574

Asia-Pacific
Shanghai, China 201206
Tel: +86 21 2892 9000

Europe
Bologna, Italy 40013
Tel: +39 051 4190611

Middle East and Africa
Dubai, United Arab Emirates
Tel: +971 4811 8100

Natural Gas Technologies

Emerson Process Management Regulator Technologies, Inc.

USA - Headquarters
McKinney, Texas 75069-1872 USA
Tel: 1-800-558-5853
Outside U.S. 1-972-548-3574

Asia-Pacific
Singapore, Singapore 128461
Tel: +65 6777 8211

Europe
Bologna, Italy 40013
Tel: +39 051 4190611
Gallardon, France 28320
Tel: +33 (0)2 37 33 47 00

TESCOM

Emerson Process Management Tescom Corporation

USA - Headquarters
Elk River, Minnesota 55330-2445 USA
Tel: 1-763-241-3238

Europe
Selmsdorf, Germany 23923
Tel: +49 (0) 38823 31 0

For further information visit www.emersonprocess.com/regulators

The Emerson logo is a trademark and service mark of Emerson Electric Co. All other marks are the property of their prospective owners. Fisher is a mark owned by Fisher Controls, Inc., a business of Emerson Process Management.

The contents of this publication are presented for informational purposes only, and while every effort has been made to ensure their accuracy, they are not to be construed as warranties or guarantees, express or implied, regarding the products or services described herein or their use or applicability. We reserve the right to modify or improve the designs or specifications of such products at any time without notice.

Emerson Process Management does not assume responsibility for the selection, use or maintenance of any product. Responsibility for proper selection, use and maintenance of any Emerson Process Management product remains solely with the purchaser.