

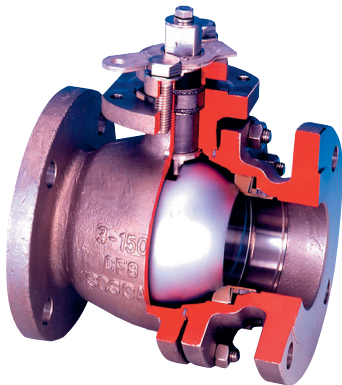

KTM OM-2 GRATITE® SEAT BALL VALVES

INSTALLATION AND OPERATION MANUAL

Before installation these instructions must be fully read and understood



Please read through this manual completely before operating the valves.
 OM-2 GratiTe Seat Ball Valves are usable for toxic or high temperature/high pressure fluid.
 Please use the valves according to warnings and cautions described in this document. Failure to do so could result in an accident due to wrong storage, installation, operation, maintenance and disassembling and/or serious damage.
 Please keep this manual in a handy place for immediate reference; be sure to provide it to purchaser, contractor, piping designer, user, operator or maintenance technician.

The contents of this manual is effective as of August 2007.
 KTM reserves the right to discontinue the manufacture of, change or modify design and/or construction of any KTM product during the manufacturing procedure, without incurring any obligation to accept for credit, to replace or furnish or install such changes or modifications on products previously or subsequently sold. This document is subject to changes without notice.

1 SAFETY PRECAUTIONS

Precautions for using KTM valves safely are highlighted with the following two warning signs according to the level of danger posed. Please read the postscript carefully to ensure safety and prevent any damage before starting to use the product.

WARNING
 A potentially hazardous situation which, if not avoided, could result in death or serious injury.

CAUTION
 A potentially hazardous situation which, if not avoided, may result in minor or moderate injury.

SELECTION GUIDE

Example:	EB11	G	31	CC	A15	15
Valve codes						
EB11 ASME 150	EB12 ASME 300					
JIS10K	JIS20K					
JPI 150	JPI 300					
Sub-codes						
G GratiTe Seat						
Body codes						
31 CF8 / SCS13A	32 CF8M / SCS14A	62 WCB / SCPH2				
Trim codes						
CC Standard trim materials						
Flange codes						
A15 ASME 150	J10 JIS10K	P013 JPI 150				
A30 ASME 300	J20 JIS20K	P033 JPI 300				
Size						
15 mm ~ 200 mm [1/2" ~ 8"]						

KTM OM-2 GRATITE® SEAT BALL VALVES

INSTALLATION AND OPERATION MANUAL

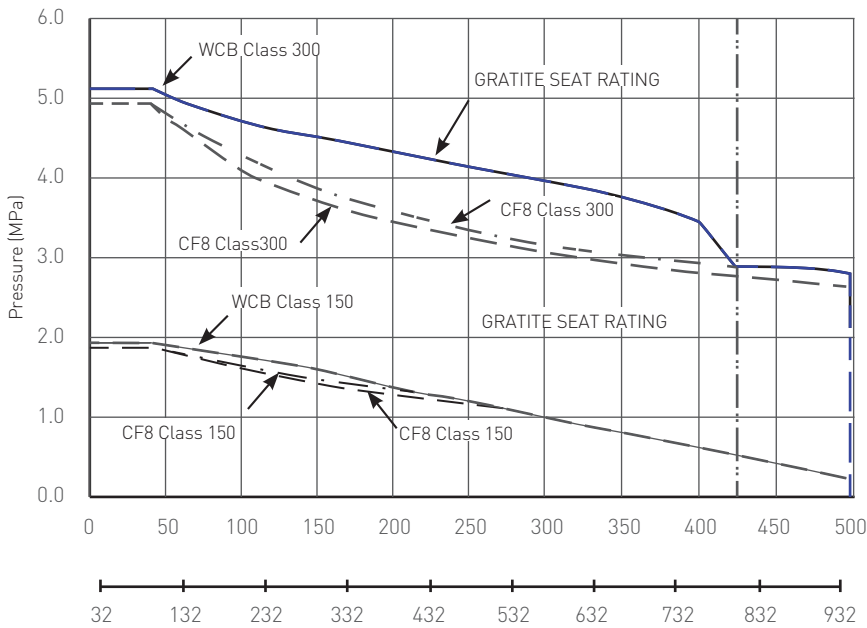

2 SPECIFICATION

The safety of the valves and conformity with your equipment should be checked by the design engineer or those who determine the specification based on the catalog or other technical data.

Upon arrival, the applicable conditions (temperature, pressure, fluid-characteristics, environmental conditions, mounting gauge etc.) should be first checked to make sure they are correct.

For the standard specifications, refer to the table below and the catalog.

3 RANGE OF APPLICATION

Pressure/Temperature Rating
OM-2 Gratite seat ball valves have a range of application defined by temperature and pressure. Please operate the valve within the range shown below. Operating the valve outside that range may result in failure of valve body or parts and leakage of the fluid. (The pressure/temperature rating is defined by body material and seat material.)

CAUTION

The maximum temperature for applications to oxidative fluids and in oxidative environment is 449°C.

The maximum temperature for models with nominal diameters 6" (150 mm) and 8" (200 mm) is normally 350°C.

WARNING

Do not use valves beyond specifications or limits indicated in the catalog.

CAUTION

1. These models may be used indoors or outdoors. If however used in an environment exposed to gas, an appropriate type and material should be used to prevent corrosion or rusting. (Details on the component materials are provided in the catalogs.)
2. To prevent accidents, custom-made valves for special treatment and operation should be ordered for specific applications using oxygen and hydrogen peroxide.

4 STORAGE AND PRESERVATION BEFORE INSTALLATION

The storage of the valves should be in accordance with the following criteria:

1. Storage warehouse should be clean and dry.
2. The ball must be in open position and the end flanges must be protected with appropriate seal discs.
3. Do not remove the bore protection cover until installation to avoid rust and contamination with foreign substances.
4. Periodical checks have to be carried out in the storage area to verify that the above mentioned conditions are maintained.

KTM OM-2 GRATITE® SEAT BALL VALVES

INSTALLATION AND OPERATION MANUAL

CAUTION

1. The ball valves are delivered with the ball in full-open position and should be stored as they are. Keeping the ball in other positions, incl. half-open position, for an extended period of time could cause seat leakage.
 2. Do not place consignment package directly on the ground.
 3. Do not expose consignment packages to the rain/wind or directly to the sun.
 4. Storage in an open area for a limited period can be considered only if the valves have appropriate packing (packed in cases covered with vinyl sheets protecting from rain, wind, dust etc).
 5. Store in a dry and well ventilated condition.
 6. If storage is anticipated for an extended period, the desiccant bags (if supplied) should be changed every six months.
3. Define the preferred mounting orientation with respect to the system pressure. Where applicable, the arrow on the body helps to identify the upstream side (high pressure) and downstream side (low pressure).
 4. Fasteners like bolts and nuts at each connecting portion on the valve should be checked and retightened in case they were loosened due to shock during transportation. When tightening nuts, use a closed wrench for safety.
 5. Before installation, the protection cover on the bore must be removed.
 6. Manually operated valves, may be installed on pipes at any angle, horizontally, vertically or any other direction. It is however recommended to consider facilitating maintenance and operation of the valve.
 7. Maintenance space must be provided.

5 TRANSPORTATION

WARNING

1. When handling valves, the correct equipment and accessories (slings, fasteners, hooks etc.) must be sized and selected, taking into consideration the individual and/or overall valves weight indicated in the packing list and/or delivery note.
2. Lifting and handling must be done only by qualified personnel. Improper hoisting can cause valve deformation or damage from dropping the valve.
3. Do not lift the valves by using lifting points or lugs located on the actuator, as these lifting points/lugs are for the actuator only.
4. Do not lift the valve by its hand-lever as these levers are not designed to take the load of the whole valve. Doing so may cause the lever to brake off or be disconnected from the valve, resulting in possible valve damage or a person's injury.
5. Avoid lifting over people's heads, equipments or anything else that can possibly be damaged or cause of injury in the event that the lifted load falls off the handling equipment.
6. All local safety regulations must be observed and complied with at all times.

6 INSTALLATION

The following instructions will make for a satisfactory and long life service of the valve.

1. Remove the valve from the shipping package (box or pallet) carefully to avoid any damage to the valve and actuator (plus accessories where applicable).
 2. Confirm that the materials of construction listed on the valve nameplates are appropriate for the intended service and are according to specifications. When in doubt, contact KTM or your local Emerson facility.
3. If the piping system is pressurized with water for testing, and if the piping system has been shut down for a long time after testing, the following measures should be taken:
 - Use corrosion inhibitor with water to pressurize the piping system.
 - After testing, the piping system should be depressurized and the test water completely drained.
 - Ensure that the corrosion inhibitor does not leave a residue within the system as the particulates may damage the valve sealing surfaces.

CAUTION

1. Ensure that there are no solid objects such as pieces of wood, plastic or packing materials within the valve or on the valve seat. It is recommended to flush pipes before installing the valve. If this is not possible, the installed valve must be in its open position before flushing takes place.
2. Unless otherwise recommended by KTM, the valves should be installed with the ball in open position to ensure that the seat rings are not damaged during installation.
3. Use appropriate gaskets which comply with standards or specifications.
4. Tighten the flange bolts with a closed wrench, using a 'crisscross' pattern that alternately tightens the bolts located 180 degrees apart (see Fig. 1). Unequal partial tightening places stress on lined pipes which may damage the flange or produce excessive operation torque.
5. Failure to fabricate pipes without excessive stress will result in leakage, poor operation or failure of the valves.
6. When conducting a pressure test of the pipe system, the valves should be in a partially open position. Testing at closed position will impose too much load and will cause leakage from seats. Check for any leakage from the joint flange and gland portion during the pressure test. After conducting pressure test, return to fully open/closed position at once.
7. If the piping system is pressurized with water for testing, and if the piping system has been shut down for a long time after testing, the following measures should be taken:
 - Use corrosion inhibitor with water to pressurize the piping system.
 - After testing, the piping system should be depressurized and the test water completely drained.
 - Ensure that the corrosion inhibitor does not leave a residue within the system as the particulates may damage the valve sealing surfaces.

KTM OM-2 GRATITE® SEAT BALL VALVES

INSTALLATION AND OPERATION MANUAL

FIGURE 1
Tightening of bolts

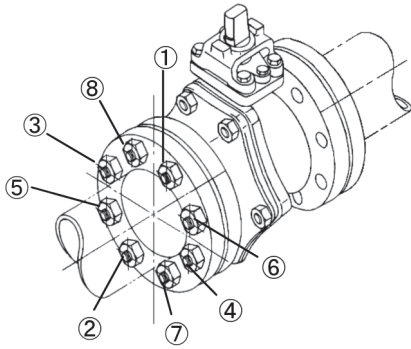

FIGURE 2
Lever handling valve

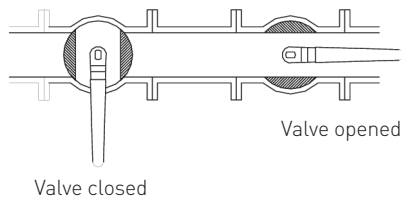
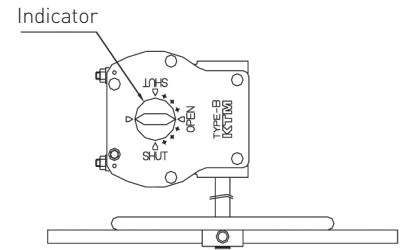

FIGURE 3
Gear operated valve



7 OPERATION

7.1 Operation Instruction

Valve adjustment is performed through lever/gear operation. Turning the stem clockwise shuts the valve. Check the operation of the valve by stroking it to "fully open" and "fully closed". Either the hand lever or the direction of the parallel flats on the top of the stem indicate the open or close position of the KTM ball valves (Figure 2). For gear operated valves, the position is indicated by the arrow-indicator (Figure 3).

CAUTION

Avoid using the valves at half-open position, since it may result in seat deformation and leakage.

WARNING

1. Operate the valve taking up a stable posture, after checking that the specified handle is fastened by bolts/ nuts or snap ring/ set screw. Also, when operating the valve with a spare handle, please make sure that the handle is reliably inserted into the stem's end. Insufficient insertion and forced operation of the handle may result in damage or injury if the handle slips out.
2. Excessive handle operation may break the lever, injure the operator, and/or deform the stopper or the stem, which may also result in seat leakage.
3. Be careful in handling the valve where high temperature fluid flows in the pipeline. The heated valve may cause burn injury of bare hands.

7.2 Gear operated valve adjustment

If the gear-operated mechanism indicator does not correctly indicate whether the valve is completely open or shut, adjust the opening with the adjustment screw. For details, refer to document No. C325-330, "Instruction Manual of A, B, C and D typed Gear Operational Valves".

7.3 Key-lock (option)

A locking device at the open and shut positions can be provided to prevent unauthorized or incorrect operation. Unlock and detach the padlock when you open/shut the valves, otherwise padlock and stopper might break. To lock the OM-2 Gratite seat ball valves, use locks of the sizes indicated in the table below.

FIGURE 4
Lock pin and pad lock

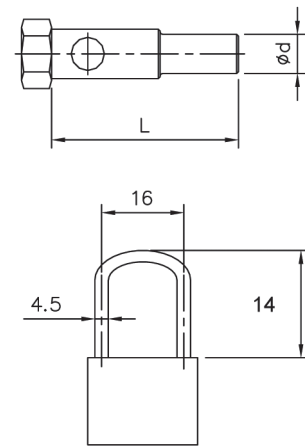
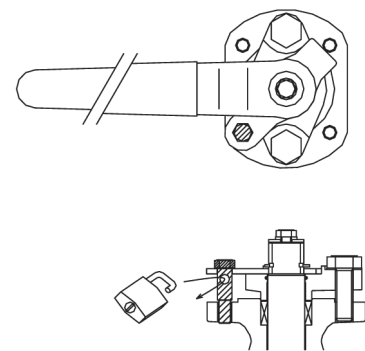

FIGURE 5
Locking example



PAD LOCK DIMENSIONS (mm)

Valve nominal diameter (Full bore)	Pin dimensions		(for reference)
	L	d	Pad lock type (m/m) Alpha No.
15~25	25	4.9	1000-25
40~50	31	6.5	1000-25
65~100	39	8	1000-25
125~200	*		1000-25

* Unnecessary

KTM OM-2 GRATITE® SEAT BALL VALVES

INSTALLATION AND OPERATION MANUAL

FIGURE 6

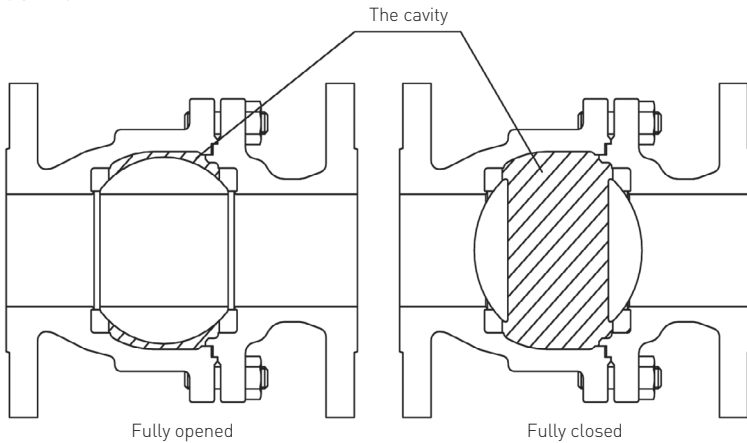

8 ABNORMAL PRESSURE RISE

CAUTION

Malfunction or damage of sealing material of the ball valves may occur due to abnormal pressure rise caused by fluid trapped in the cavity (Fig. 6) between the body, ball and seat.

KTM is taking measures to ensure that pressure in both cavity and the pipes will be equalized when the valves are at opened position.

Abnormal pressure rise can be caused by:

1. Rapid heating of valve exterior
2. Exposure to high temperature fluid after the valve is closed
3. Location near a heat source

Please contact us concerning countermeasures for these problems, such as providing a pressure-relieving hole on the surface of a ball that is subject to high pressure.

9 MAINTENANCE

The following instructions will contribute to a long life service of the valve. Periodical checks and maintenance are required to keep valves in good working condition. Parts to be checked periodically and maintenance items are shown in below Figures 7 to 9.

CAUTION

If leakage is observed through the gland packing, tighten the gland bolts slowly and evenly until the leakage stops. This must be accomplished without affecting the torque. Do not over-tighten the packing gland bolts, since this will increase the torque required to operate the valve.

This procedure should be performed every 3000 operation cycles or every six months of service. When gland packing is expected to be loosened due to the heat cycle, retighten the screws every two months of service or every 1000 operational cycles.

Gland seals on gear operational valves are almost same as nominal diameters 125 mm to 250 mm. The stems have been designed as "anti-blow out" to improve safety during system operation. This means that the stem cannot be removed from the valve body through the top of the body. It must be removed from within the valve body.

FIGURE 7

EB11G 15 mm ~ 100 mm (1/2"~4")
EB12G 15 mm ~ 100 mm (1/2"~4")

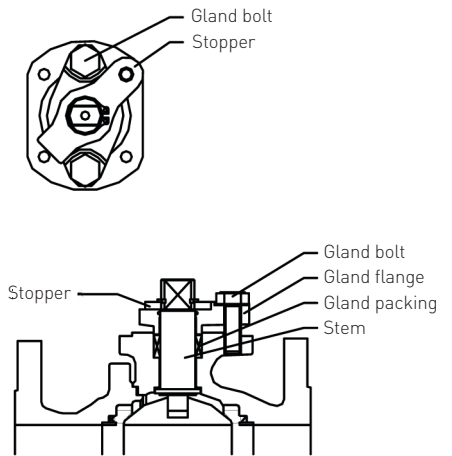
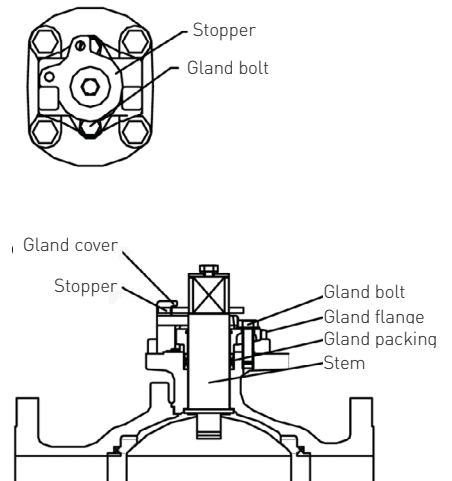

FIGURE 8

EB11G 125 mm ~ 200 mm (5"~8")
EB12G 125 mm ~ 200 mm (5"~8")



KTM OM-2 GRATITE® SEAT BALL VALVES

INSTALLATION AND OPERATION MANUAL

FIGURE 9
Body sealing structures

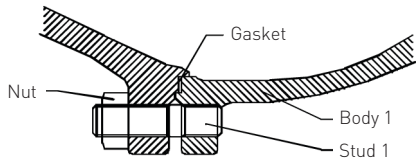

CAUTION

The sealing portion between body and body cap is provided with a graphite gasket as shown in Figure 9. In case of slight leakage, the fastening bolts should be moderately tightened.

10 TROUBLESHOOTING

Trouble examples	Causes	Measures
Unsmooth operation	<ol style="list-style-type: none"> 1. Jamming due to solids or slurry in the fluid. 2. Ball is corroded by fluid. 3. Fluid sticks to ball and seats. 4. Unusual pressure rise exceeding seat rating limit when shutting the valve. 	<ol style="list-style-type: none"> 1. Clean the inside of the valve. If necessary, replace parts (ball, seats, stem bearing, thrust bearing). 2. Replace with ball made off corrosion resistant material. 3. Clean the inside of the valve. If necessary, replace ball or seats, or replace with ball valve equipped with metal seats. 4. Take measures to prevent abnormal pressure rise in pipe and replace seat.
Outside leakage	<ol style="list-style-type: none"> 1. Sealing performance of gasket and gland packing decreases gradually when operation frequency is high or the high temperature fluid flows 2. Sealing performance of gasket and gland packing decreases by abnormal pressure rise in the cavity. 3. Sealing performance of gasket and gland packing decreases when shutting the valve during abnormal pressure rise in the piping. 	<ol style="list-style-type: none"> 1. The fastening nuts or bolts at gasket and gland packing are required to be lightly tightenend, or gasket and gland packing replaced. 2. Replace by ball equipped with small purge hole for releasing abnormal pressure rise. 3. Take measures to prevent pressure rise and replace seats, gaskets and gland packing.
Seat leakage	<ol style="list-style-type: none"> 1. Ball and seats are damaged by solids and slurry in the fluid. Fluid sticks to ball and seats. 2. Ball is corroded by fluid. 3. Seat and cushion deformation due to abnormal pressure rise in the cavity. 4. Unusual pressure rise exceeding seat rating limit is when shutting the valve leads to seat deformation. 	<ol style="list-style-type: none"> 1. Clean the inside of the valve. If necessary, replace ball or seats, or replace with ball valve equipped with metal seats. 2. Replace with ball made of corrosion resistant material. 3. Replace by ball equipped with small purge hole to release abnormal pressure rise. 4. Take measures to prevent abnormal pressure rise and replace seats.

11 VALVE DISASSEMBLY

Assemble/disassemble the valves in a clean, well-lit and well ventilated place.

WARNING

Before removing the valve from the piping, ensure that the system has been fully depressurized and any dangerous fluids have been drained off. Failure to do so may cause serious personal injury and/or damage to the valve. Maintenance of the valves must be performed only by qualified personnel. Never operate/disassemble the valves before checking the safety. The valve is extremely heavy; ensure a stable position to prevent it from falling down when assembling/disassembling. There is a cavity inside the ball valve when the ball is fully open or fully closed. For a safe disassembly, following instructions must be carried out.

1. Half open the valve when still installed in piping, and make no pressure remains in the cavity. Failure to do so may result in injury, explosion or fire caused by the remaining pressure.
2. Before disassembling the valve, make sure that it has been decontaminated of any harmful gasses or fluids, and disassembly is done at a well ventilated place and within a safe temperature range for maintenance.
3. Pressure of flammable gas and other dangerous fluids must be checked only at well ventilated places outdoors, far away from any fire source.

KTM OM-2 GRATITE® SEAT BALL VALVES

INSTALLATION AND OPERATION MANUAL

Refer to below construction drawing for disassembly. The numbers of parts vary slightly depending on the valve size, but the basic structures are identical.

FIGURE 10
Parts construction (Nominal diameter: 80 mm)

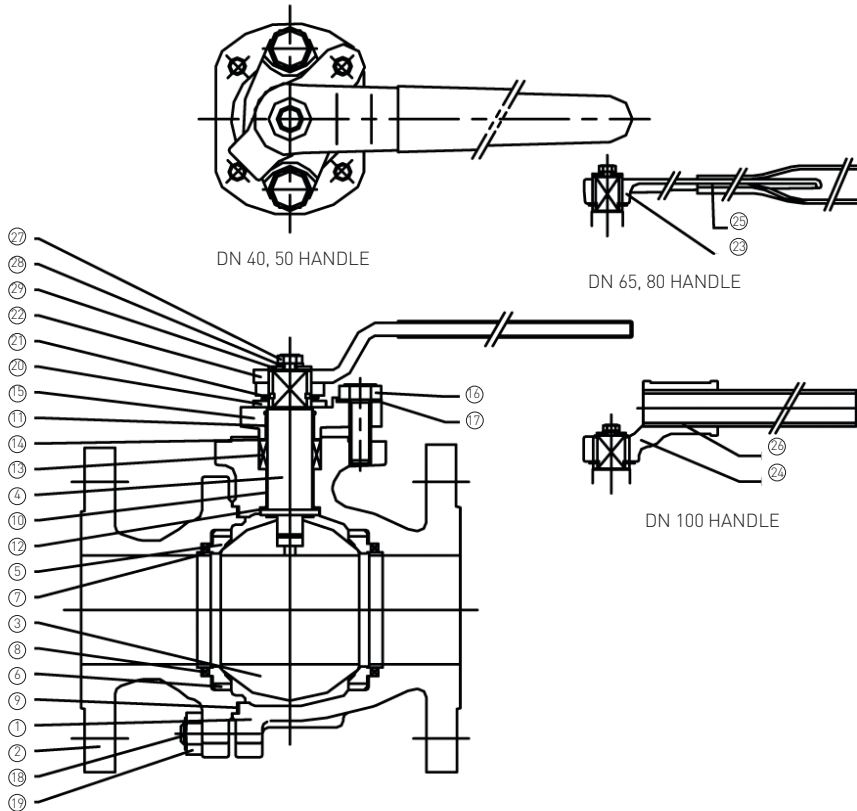

PARTS LIST

Part	Name
1	Body
2	Body cap
3	Ball
4	Stem
5	Seat
6	Seat retainer
7	Inner ring
8	Cushion
9	Gasket
10	Stem bearing
11	Stem bearing
12	Thrust bearing
13	Gland packing
14	Packing washer
15	Gland flange
16	Gland bolt
17	Live loading spring
18	Stud
19	Nut
20	Stopper
21	Snap ring
22	Handle (DN 40,50)
23	Handle (DN 65,80)
24	Handle head (DN 100)
25	Pipe (DN 65,80)
26	Pipe (DN 100)
27	Hexagon bolt
28	Spring washer
29	Washer

[Sending the valves back to us and requesting repair]

12 WARRANTY

CAUTION

1. The ball valve has a cavity in its interior when a ball is fully open or fully closed. Since some pressure and fluid may remain inside the cavity, be sure to release pressure and purge fluids completely by keeping the valve half-open when removing the valve from the piping or sending them back to us.
2. Please return the valve without disassembling.

The warranty period is one year from the date of installation by the first use of the goods, or eighteen (18) months from the date of shipment to the first user, whichever occurs first.

Neither Emerson, Emerson Automation Solutions, nor any of their affiliated entities assumes responsibility for the selection, use or maintenance of any product. Responsibility for proper selection, use, and maintenance of any product remains solely with the purchaser and end user.

KTM is a mark owned by one of the companies in the Emerson Automation Solutions business unit of Emerson Electric Co. Emerson Automation Solutions, Emerson and the Emerson logo are trademarks and service marks of Emerson Electric Co. All other marks are the property of their respective owners.

The contents of this publication are presented for informational purposes only, and while every effort has been made to ensure their accuracy, they are not to be construed as warranties or guarantees, express or implied, regarding the products or services described herein or their use or applicability. All sales are governed by our terms and conditions, which are available upon request. We reserve the right to modify or improve the designs or specifications of such products at any time without notice.