

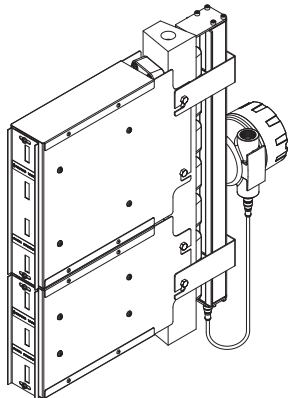

YARWAY LED ILLUMINATOR SYSTEM FOR COLOR-PORT GAUGES

INSTALLATION, OPERATION AND MAINTENANCE INSTRUCTIONS

Before installation, these instructions must be carefully read and understood.



Tables and figures

Table 1 - Model structure.....	3
Figure 1 - Exploded parts diagram	7
Figure 2 - Installation of LED illuminator and level display to color-port gauge.....	7
Figure 3 - Red/green colored glass orientation...	7
Figure 4 - Accessories views	8
Figure 5 - Wiring installation.....	8
Figure 6 - Control drawings.....	9
Figure 7 - Nameplates	10

TABLE OF CONTENTS

1 Safety information	1
2 Introduction	2
2.1 System description	2
2.2 Accessories	2
3 Available models	2
3.1 Power requirements and specifications	2
3.2 Approvals	2
4 Inspection	4
5 Installation.....	4
5.1 Inspection and cleaning of glass	4
5.2 Assembly - pre-installation	4
5.3 Installation of unit to gauge	4
5.4 Electrical installation.....	5
6 Operation	5
7 Maintenance	5
7.1 Preventative maintenance.....	5
7.2 Maintenance procedures	5
7.3 Troubleshooting	5
7.4 Allowable modifications	5
8 Removal - disassembly - reassembly	6
8.1 Disassembly.....	6
8.2 Reassembly.....	6
9 Packaging, storage and transportation ...	6
9.1 Packaging.....	6
9.2 Storage	6
9.3 Transportation.....	6
10 Disposal at end of useful life	6
11 Warranty.....	6
12 Telephone assistance	6
13 Exploded parts diagrams.....	7

1 SAFETY INFORMATION

IMPORTANT

It is the user's responsibility to ensure that all connections and wiring comply with all applicable codes, specifications, sales contracts or public laws.

IMPORTANT

The sales order lists the required operating voltage. Operation at a voltage other than specified will cause equipment damage.

The Color-Port gauge operates at the boiler saturation temperature. High surface temperatures can be expected where this equipment connects to the gauge.

WARNING

Do not touch until the unit has cooled.

The Color-Port gauge must be adequately supported to hold the combined weight of LED illuminator, level display and hood (if applicable). Shut-off LED illuminator before doing any maintenance or repairs.

YARWAY LED ILLUMINATOR SYSTEM FOR COLOR-PORT GAUGES

INSTALLATION, OPERATION AND MAINTENANCE INSTRUCTIONS

2 INTRODUCTION

Yarway LED illuminators are designed to be mounted readily to the Yarway Color-Port gauge, as well as most competitive color-port gauges.

All illuminators are complete with a color screen containing two strips of glass - one red and one green. Due to the difference in the index of refraction of light through water and steam, only the corresponding color is seen: green for water, red for steam.

Yarway LED illuminators are available in lengths from 5 ports to 26 ports.

2.1 System description

Yarway LED illuminators comprise five main components. Use the exploded parts diagrams in Section 13 as additional reference material.

Illuminator - light source. It is composed of an anodized, rigid, extruded aluminum that protects the PC boards.

Bracket - used to mount illuminator to Color-Port gauge. The brackets can be moved up and down along the extruded body making assembly and disassembly quick and easy.

Power supply - provides intrinsically safe power to the LED illuminator. Power supply is mounted inside an explosion proof enclosure that is mounted to the illuminator body.

Cordset - used to connect the power supply to the illuminator. The cordset consists of a straight female connector and a straight male connector.

Level display - focuses the light from the LED illuminator to show the level.

2.2 Accessories

Level display hood and hooded mirror - enhance the images for outdoor installations or redirect the image for viewing below the gauge.

3 AVAILABLE MODELS

Yarway LED illuminators are made to fit/cover the whole length of the Color-Port gauge. One power supply is required per 26 ports (208 LEDs). On average an LED will give the user 100,000 hours of use compared to 1000 hours for a standard light bulb.

3.1 Power Requirements & Specifications

Input: 115/230 VAC \pm 10%, 50/60 Hz

Power consumption: up to 400 mA max at 115/230 VAC

Max distance from power supply to LED

illuminator: 200 ft. (consult Emerson if longer distance is required)

Ambient temperature range for general

location: -40°F to 158°F (-40°C to 70°C)

Ambient temperature range for hazardous

location: -40°F \leq ta \leq +140°F (-40°C \leq ta \leq +60°C)

Ingress protection: IP66

Max altitude: 6.561 ft.

Electrical connection size:

3/4" FNPT for US and Canada

M20 for ATEX and IECEx

- Unit must be wired with 14 AWG wire minimum, with a maximum wire length of 1000 feet.
- An external switch or circuit-breaker and external overcurrent protection is recommended to be installed near the unit.
- Unit can be use indoors and outdoors.
- Maximum relative humidity 80% for temperatures up to 88°F (31°C) decreasing linearly to 50% relative humidity at 104°F (40°C).

WARNING

Do not tamper with Yarway's power supply or its components.

3.2 Approvals

General location

UL61010-1/CSA C22.2 No. 61010-1

Explosion-proof with intrinsically safe output

MET Certified for US and Canada

Class I Division 1 Groups A*, B, C, D T4

* only for Mounting Option 2

ATEX Approved

Ex II 2G (Power Supply)

Ex d [ia Ga IIC] IIC T4 Gb

Ex II 1G (Illuminator)

Ex ia IIC T4 Ga

IECEx Approved

Ex d [ia Ga IIC] IIC T4 Gb (Power Supply)

Ex ia IIC T4 Ga (Illuminator)

When installed in accordance with Emerson Control Drawings:

- For Division Locations - 18WL4-009 (Figure 6A)
- For ATEX/IECEx - 18WR6-009 (Figure 6B)

YARWAY LED ILLUMINATOR SYSTEM FOR COLOR-PORT GAUGES

INSTALLATION, OPERATION AND MAINTENANCE INSTRUCTIONS

TABLE 1 - MODEL STRUCTURE

Example:	ILCP	25	05	1	G	S
Illuminator model						
ILCP Illuminator LED Color Port						
Port spacing						
25 2.5" pitch						
28 2.875" pitch						
Illuminator size (gauge size)						
Number of ports (05 – 26)						
Input voltage						
1 115 VAC 50/60 Hz (¾ NPT inlet)						
2 230 VAC 50/60 Hz (M20 inlet)						
3 115 VAC 50/60 Hz (M20 inlet)						
4 230 VAC 50/60 Hz (¾ NPT inlet)						
Application location						
G General locations						
D Division locations (MET for US and Canada)						
Z Zone locations (ATEX and IECEx)						
Installation configuration						
S Standard						
C Chain connection (staggered gauges)						
R Remote mount power supply						
A Chain connection (staggered gauges) and remote mount power supply						

Conditions of Use for Ex Component

- 1 Tserv according to use seal:
TPE: -40÷100/85°C - lower temperature for housing with sight glass
VMO: -40÷100/85°C - lower temperature for housing with sight glass
FKM: -20÷200/85°C - lower temperature for housing with sight glass
- 2 Max number, size and position of apertures - are given in Application manual N-L2237 dated 31.03.2016
- 3 For information on the dimensions of the flameproof joints the manufacturer shall be contacted.
- 4 Apparatus installed inside of enclosure can have any lay-out, which ensures that in any cross section area will be at least 40% (group IIC) of area free
- 5 The enclosure with Ex component certificate can be applicate only by assumption of filling requests of the standard IEC 60079-1:2014, cl. D.3.10
- 6 Appropriately certified cable glands for direct entry have to be used
- 7 IP 68 max (h=1 m)
- 8 The max overpressure static test of housing: 50 bar/10 s
- 9 Max power dissipation for temperature class, see ANNEX to IECEx Certificate No. IECEx FTZU 12.0017U Issue No. 0

YARWAY LED ILLUMINATOR SYSTEM FOR COLOR-PORT GAUGES

INSTALLATION, OPERATION AND MAINTENANCE INSTRUCTIONS

4 INSPECTION

Safety instructions

Exercise care in handling illuminator parts to avoid scratching, denting or otherwise damaging the protective glass. Any marks on the protective glass, as well as dirt, paint or tape will result in a reduction of light output. On receipt of an illuminator, check all components carefully for damage incurred in shipping. If damage is evident or suspected, do not attempt installation. Notify the carrier immediately and request a damage inspection. Refer to the exploded view drawing in Section 13 to inventory parts.

5 INSTALLATION

Installation should only be undertaken by qualified personnel who are familiar with this equipment. They should have read and understood all of the instructions in this manual. The user should refer to relevant technical data sheets or the product proposal to obtain dimensional information for the specific size and model illuminator. It is the user's responsibility to assure that knowledgeable installation personnel plan and carry out the installation in a safe manner. The following procedures are some of the guidelines that should be employed:

5.1 Inspection and cleaning of glass

Prior to installation of an illuminator to a gauge, the gauge glass should be cleaned and inspected per instructions as follows:

1. Clean glass within vision ports using a non-abrasive household cleaner. DO NOT use a wire brush, metal scraper or any device which could scratch the glass.
2. Inspect the surface of the glass for any signs of clouding, etching, scratching or physical damage such as bruises, chips or erosion that penetrates the outer surface of the glass. Shining a light at approximately a 45° angle will aid in detecting some of these conditions. Light will glisten more brightly on glass imperfections than the surrounding glass when reflecting light. Detection of any such problem areas or surface wear is sufficient evidence of damage. Do not proceed with installation with damaged glass. See appropriate Installation, Operation and Maintenance manual and replace glass.

5.2 Assembly - pre-installation

1. Check the orientation of the red/green glass. The green glass must be towards the wide side of the gauge (see figure 3)
 - 1.1 If colored glass is orientated correctly no action is required
 - 1.2 If colored glass is not oriented correctly the LED illuminator must be mounted up side down. See 5.3 Installation of unit to gauge for mounting instructions.

2. Check that the level display adjustment plate (164) is oriented with view slots towards the wide side of the gauge.

5.3 Installation of unit to gauge

Become familiar with the illuminator components before proceeding with installation. Refer to the exploded parts drawing in Section 13, Figures 1 and 2. As well as Figure 5A for general locations, Figure 5B for division locations, and Figure 5C for ATEX/IECEx when performing the following installation instructions.

To assemble the illuminator and level display to a Color-Port style gauge, follow the steps below:

1. Mount level display to gauge by inserting mounting slots to the hex screws on the body of the gauge.
2. Attach the mounting brackets (73A) to the illuminator body (11) using the screws (100) and the slider brackets (73) provided. Leave two slider brackets in the middle-lower half of the illuminator for the power supply.
3. Align the mounting brackets with the mark on the back of the illuminator's body.
4. Firmly tighten down the screws (100) to secure mounting brackets (73A) to illuminator body.
5. Mount LED illuminator to gauge by inserting mounting brackets to the hex screws on the body of the gauge.
6. Make sure that the LED clusters are aligned with the ports.
7. Firmly tighten down the hex screws on the gauge body to hold the illuminator and the level display to the gauge.
8. Open the cover of the power supply enclosure and make sure the AC input voltage selector switch in the power supply matches the input voltage provided to the unit (115 VAC or 230 VAC).
9. After voltage selector switch is selecting the correct input voltage, connect/plug in the AC wires to Terminal Block 1.
10. Fully close the cover of the enclosure by hand tightening it.
11. Mount power supply to the illuminator body using the last two slider brackets you set aside from step 2.
12. Connect the power supply to the LED illuminator using the cordset provided.

IMPORTANT FOR HAZARDOUS LOCATION ONLY

- A flame path seal-off shall be installed within 18 in. of enclosure. see Figure 5B for Division Locations.
- A flame path seal-off shall be installed directly to threaded entry of enclosure. see or Figure 5C for ATEX/IECEx.
- The LED Illuminator contains material composition capable of igniting the explosive atmosphere due to physical impact or friction. Installation shall provide inherent protection from potential impacts risks by means of installation location, guards and/or barriers.

YARWAY LED ILLUMINATOR SYSTEM FOR COLOR-PORT GAUGES

INSTALLATION, OPERATION AND MAINTENANCE INSTRUCTIONS

5.4 Electrical installation

WARNING

DO NOT proceed with electrical installation unless the illuminator has been mounted to the gauge according to instructions in Section 5.3. Only qualified electricians who have read and understood local and national electrical codes should connect the illuminator to an electrical source. Failure to follow any of these instructions may result in death, severe personal injury, property damage or damage to the illuminator and gauge.

The electrical installation should be performed by a qualified electrician and comply with applicable codes (U.S. - refer to National Electrical Code NFPA current edition; Canada - refer to Electrical Code CSA C22) or other regulations as applicable. The conduit must run in such a manner that it is not supported by or does not serve as a support for the illuminator. The unit must be grounded before it is operated.

6 OPERATION

Check that all installation procedures have been completed. Use only qualified, experienced personnel who are familiar with illuminators and thoroughly understand the implications of all the instructions. If the equipment is used in a manner not specified by the manufacturer, the protection provided by the equipment may be impaired.

7 MAINTENANCE

The user must create maintenance schedules, safety manuals and inspection details for each specific installation of an illuminator.

7.1 Preventative maintenance

On all installations the following items should be evaluated regularly by the user for purposes of maintenance:

1. Protective glass/colored glass, for signs of dirt build up, scratches or breakage
2. Mounting bracket for signs of loosening

The user must determine an appropriate maintenance schedule necessary for his or her specific application, upon evaluation of their own operating experience. Realistic maintenance schedules can only be determined with full knowledge of the services and application situation involved.

7.2 Maintenance procedures

Cleaning the protective glass/colored glass -

wash with a non-abrasive soap or detergent and water using a soft, grit-free cloth or sponge. When cleaning grease and oil from the protective glass/colored glass, use a chemical compatible with silicone rubber only and a soft, grit-free cloth. DO NOT use solvents such as acetone, benzene, carbon tetrachloride, dry cleaning fluid or lacquer thinners since they will attack the surface of the protective glass/colored glass and or the gaskets. After the surface has been cleaned and rinsed of foreign particles, it may be dried with a clean, soft, damp chamois or grit-free cloth.

IMPORTANT

DO NOT use hard, rough cloths on the edge of protective glass/colored glass because they can scratch the surface. The scratches will result in reduced light output from the illuminator.

7.3 Troubleshooting

Internal or external corrosion - could be an indication of a harsh service environment. An investigation should be carried out immediately to determine the cause of the problem. It is the user's responsibility to choose a material of construction compatible with both the contained fluid and the surrounding atmosphere.

All LEDs off - could be an indication of power failure. Check the power supply and connections.

IMPORTANT

Contact the manufacturer if any part needs to be replaced.

7.4 Allowable modifications

The LED illuminator or level display are not to be modified in any way. Any modification will void warranty and could result in equipment damage or serious personal injury.

YARWAY LED ILLUMINATOR SYSTEM FOR COLOR-PORT GAUGES

INSTALLATION, OPERATION AND MAINTENANCE INSTRUCTIONS

8 REMOVAL - DISASSEMBLY - REASSEMBLY

8.1 Disassembly

Refer to the exploded parts drawing in Section 13, Figures 1 and 2, for additional reference during disassembly of the illuminator.

1. Disconnect the electrical power source from the illuminator.
2. Loosen hex screws on the gauge body (do not remove).
3. Remove LED illuminator by moving up and away from gauge.
4. Remove level display by moving up and away from gauge.

8.2 Reassembly

Refer to the exploded parts drawing in Section 13, Figures 1 and 2, for additional reference during reassembly of the illuminator.

1. Mount level display to gauge by inserting mounting slots to the hex screws on the body of the gauge.
2. Mount LED illuminator to gauge by inserting mounting brackets to the hex screws on the body of the gauge.
3. Make sure that the LED clusters are aligned with the ports.
4. Firmly tighten down the hex screws on the gauge body to hold the illuminator and the level display to the gauge.
5. Connect electrical power source to the illuminator.

9 PACKAGING, STORAGE AND TRANSPORTATION

9.1 Packaging

The LED illuminator and level display contain fragile components and must be handled with care. These units must be packed to prevent damage during transportation. If damage to the colored glass or lens should occur during shipment contact the factory.

9.2 Storage

The LED illuminator and level display can be stored outside. These units are not affected by temperature or humidity.

9.3 Transportation

Since these components contain fragile parts, care should be taken to ensure that the units arrive undamaged. After unpacking units, each unit should be inspected and any damaged parts should be replaced before assembly and installation.

10 DISPOSAL AT END OF USEFUL LIFE

Yarway illuminators' metal and polymers should be recycled whenever possible. Refer to the order and applicable technical data sheets for materials of construction.

11 WARRANTY

See sales order acknowledgements for terms and conditions of sale.

12 TELEPHONE ASSISTANCE

If you are having difficulty with your illuminator, notify your local Yarway distributor. You may also contact the factory direct at (281) 274-4400 and ask for an applications engineer. So that we may assist you more effectively, please have as much of the following information as possible when you call:

- Model #
- Name of the company from whom you purchased your illuminator
- Invoice # and date
- Operating temperatures
- A brief description of the problem
- Troubleshooting procedures that failed

If attempts to solve your problem fail, you may be requested to return your illuminator to the factory for intensive testing. You must obtain a Return Authorization (RA) number from Emerson prior to returning anything. Failure to do so will result in the unit being returned to you, without being tested, freight collect. To obtain an R.A. number, the following information (in addition to that above) is needed:

- Reason for return
- Person to contact at your company
- 'Ship-to' address

There is a minimum charge for evaluation of non-warranty units. You will be contacted before any repairs are initiated should the cost exceed the minimum charge. If you return a unit under warranty, but it is not defective, the minimum charge will apply.

YARWAY LED ILLUMINATOR SYSTEM FOR COLOR-PORT GAUGES

INSTALLATION, OPERATION AND MAINTENANCE INSTRUCTIONS

13 EXPLODED PARTS DIAGRAMS

FIGURE 1
Exploded parts diagram

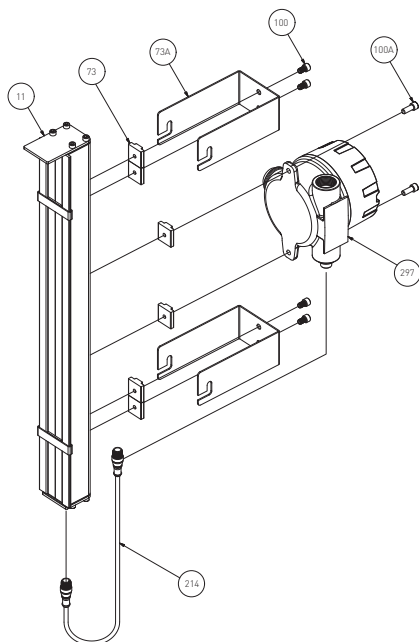

PARTS LIST

Ref #	Item
11	Body LED illuminator
72	Slider bracket
73A	Mounting bracket
100	Screw
100A	Screw
214	Cordset
297	Enclosure

FIGURE 2
Installation of LED illuminator and level display to Color-Port gauge

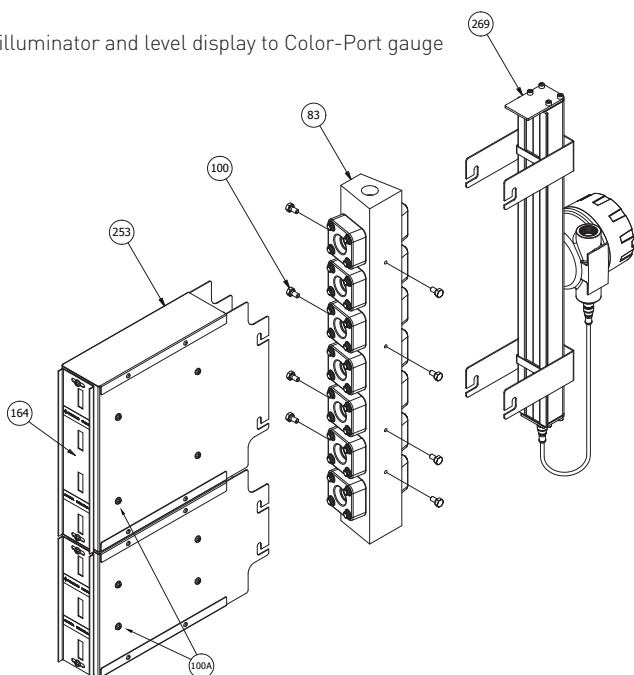

PARTS LIST

Ref #	Item
83	Color-Port gauge
100	Hex screw
100A	Screw
164	Adjustment plate
253	Level display
269	LED illuminator

FIGURE 3
Red/green colored glass orientation

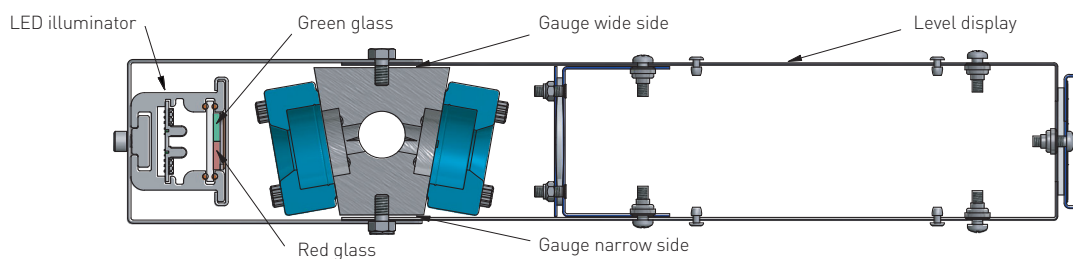

YARWAY LED ILLUMINATOR SYSTEM FOR COLOR-PORT GAUGES

INSTALLATION, OPERATION AND MAINTENANCE INSTRUCTIONS

FIGURE 4
Accessories views

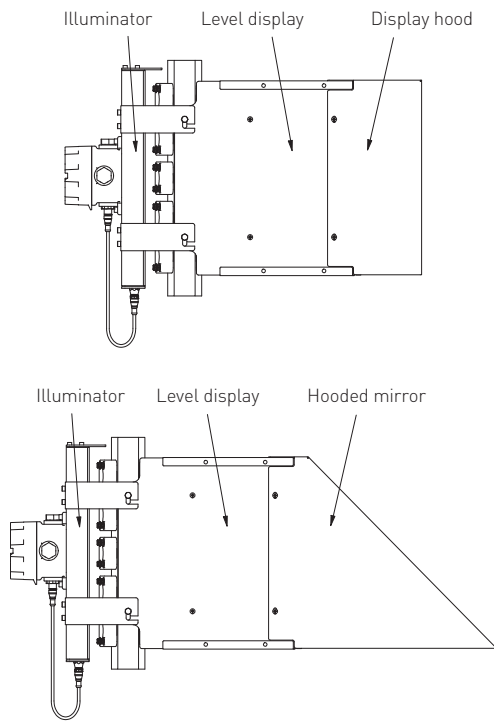

FIGURE 5A
Wiring installation - General locations

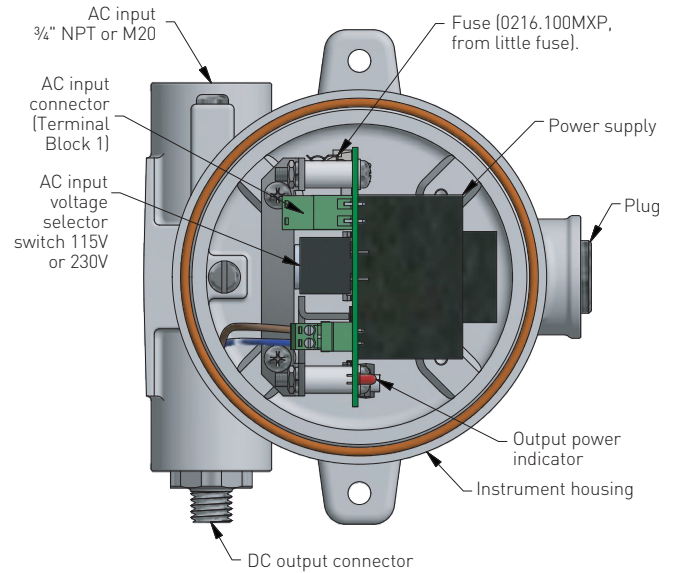

FIGURE 5B
Wiring installation - Division locations

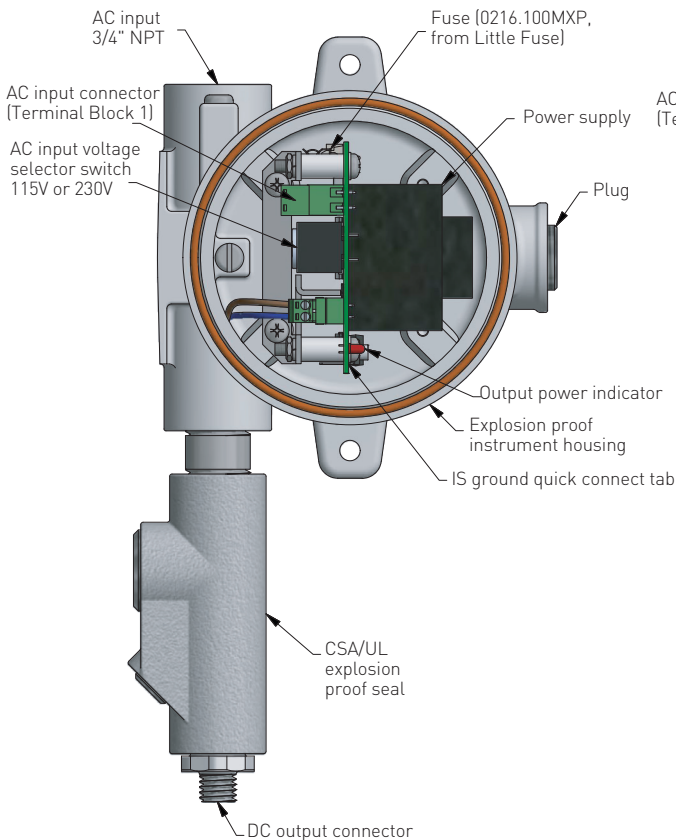
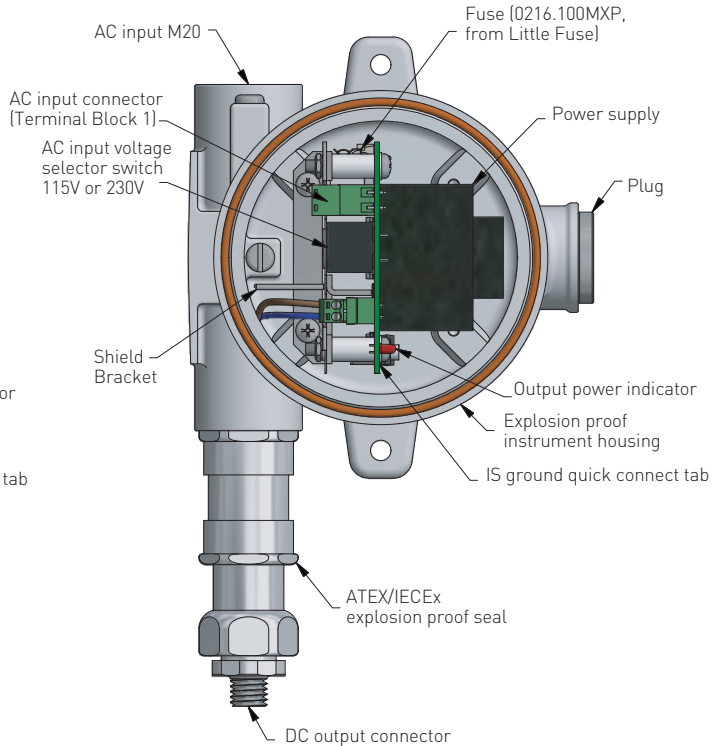

FIGURE 5C
Wiring installation - ATEX/IECEX locations



YARWAY LED ILLUMINATOR SYSTEM FOR COLOR-PORT GAUGES

INSTALLATION, OPERATION AND MAINTENANCE INSTRUCTIONS

FIGURE 6A
Control drawing for division locations

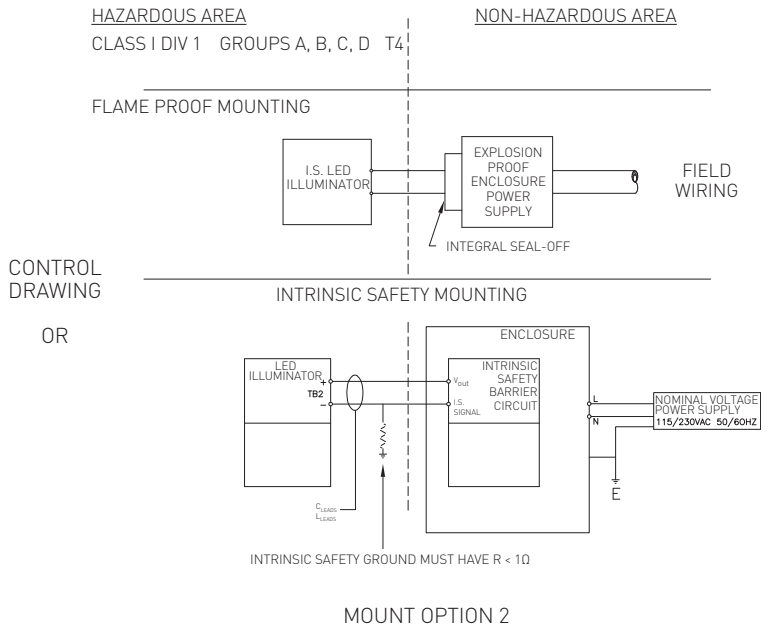
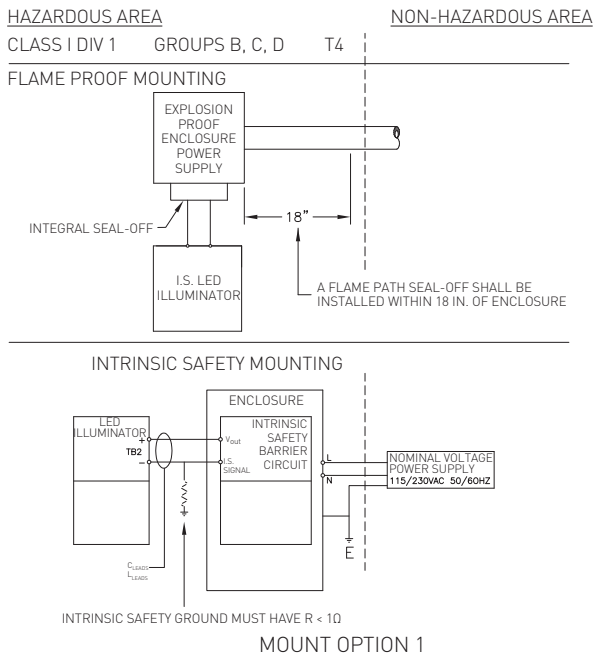

NOTES: Equipment supplying intrinsic system must not produce more than $125/250 V_{rms}$.
 Loop wire distance not to exceed 200 ft. using $C_{Leads} = 60pF/ft.$ $L_{Leads} = \mu H/ft.$
 Consult Emerson if longer distance needed.
 Barrier ground shall be connected to a grounding electrode by redundant, 12 AWG or larger insulated conductors.
 The installation must be in accordance with Canadian Electric Code CSA C22.1 Part 1, Appendix F.
 The installation must be in accordance with National Electric Code, NFPA 70, Articles 504 and 505, and ANSI/ISA-RP12.06.01.

FIGURE 6B
Control drawing for ATEX/IECEx

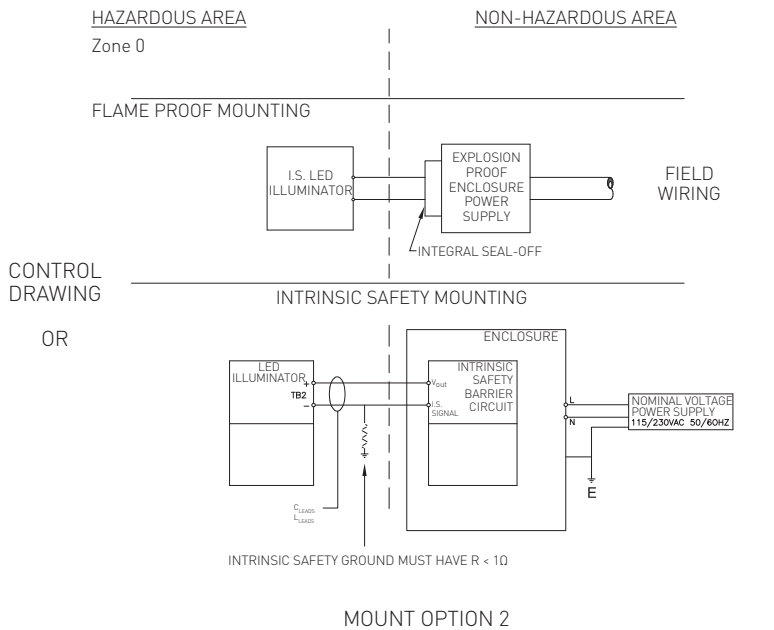
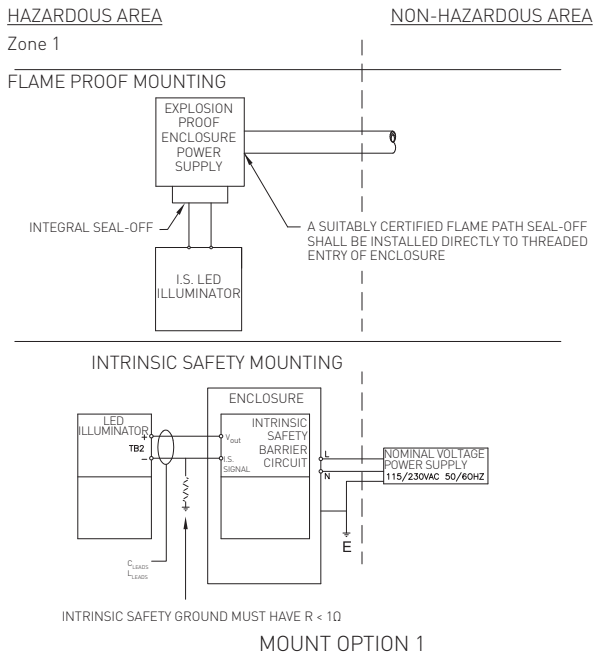

NOTES: Equipment supplying intrinsic system must not produce more than $125/250 V_{rms}$.
 Loop wire distance not to exceed 200 ft. using $C_{Leads} = 60pF/ft.$ $L_{Leads} = \mu H/ft.$
 Consult Emerson if longer distance needed.
 The installation must be in accordance with National Electric Code, NFPA 70, Articles 504 and 505, and ANSI/ISA-RP12.06.01.

YARWAY LED ILLUMINATOR SYSTEM FOR COLOR-PORT GAUGES

INSTALLATION, OPERATION AND MAINTENANCE INSTRUCTIONS

FIGURE 7A
Nameplate - General locations



FIGURE 7B
Nameplate - Division locations

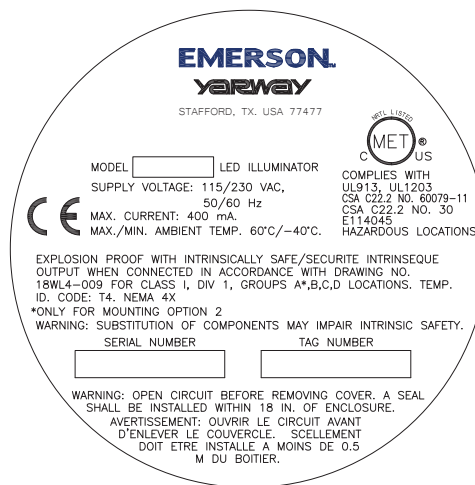

FIGURE 7C
Nameplate - ATEX/IECEX

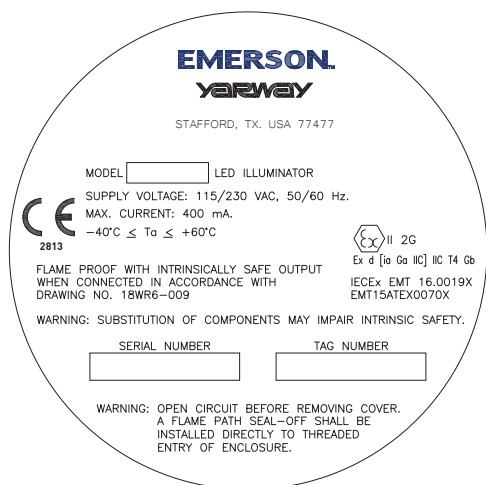
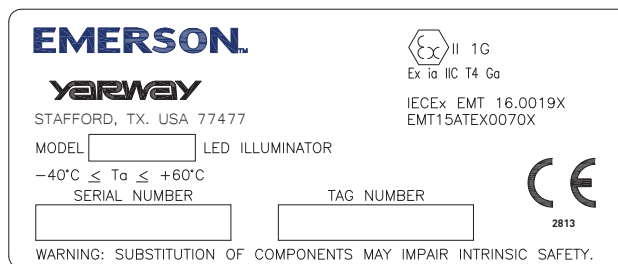

FIGURE 7D
Nameplate - Division locations



VCIOM-04070 © 2017, 2022 Emerson Electric Co. All rights reserved 05/22. Yarway is a mark owned by one of the companies in the Emerson Automation Solutions business unit of Emerson Electric Co. The Emerson logo is a trademark and service mark of Emerson Electric Co. All other marks are the property of their prospective owners.

The contents of this publication are presented for informational purposes only, and while every effort has been made to ensure their accuracy, they are not to be construed as warranties or guarantees, express or implied, regarding the products or services described herein or their use or applicability. All sales are governed by our terms and conditions, which are available upon request. We reserve the right to modify or improve the designs or specifications of such products at any time without notice.

Emerson Electric Co. does not assume responsibility for the selection, use or maintenance of any product. Responsibility for proper selection, use and maintenance of any Emerson Electric Co. product remains solely with the purchaser.