

Type EZH Relief or Backpressure Regulator

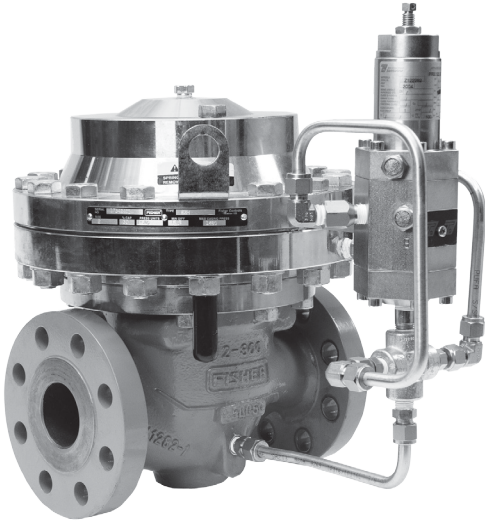

Figure 1. Type EZH Regulator



TYPE PRX/182

Figure 2. PRX Series Pilot



WARNING

Failure to follow these instructions or to properly install and maintain this equipment could result in an explosion and/or fire causing property damage and personal injury or death.

Fisher™ relief valve or backpressure regulator must be installed, operated and maintained in accordance with federal, state and local codes, rules and regulations and Emerson Process Management Regulator Technologies, Inc. (Emerson) instructions.

If a leak develops or if the outlet continually vents gas, service to the unit may be required. Failure to correct trouble could result in a hazardous condition.

Call a gas service person to service the unit. Only a qualified person must install or service the relief valve or backpressure regulator.

Introduction

Scope of the Manual

This manual provides installation, startup and maintenance instructions and parts ordering information for the Type EZH relief valve or backpressure regulator and PRX Series pilots. Information on other equipment used with this product is found in separate manuals.

Product Description

Type EZH relief valve or backpressure regulator is pilot-operated and designed for use in high pressure natural gas transmission/city gate stations, large capacity distribution systems and power plant feeds.

Pilot Descriptions

The Type EZH relief valve or backpressure regulator include a Type PRX/182 pilot mounted on the main valve. PRX Series pressure reducing pilots have the ability to handle a wide range of setpoints from 29 to 1160 psig / 2.0 to 80.0 bar.

Type EZH Relief

Specifications

Ratings and specifications for the Type EZH are listed in the Specifications section below. Specifications for specific relief valve or backpressure regulator constructions are stamped on a nameplate attached to either the main actuator or the pilot spring case.

Body Sizes, End Connection Styles and Pressure Ratings⁽¹⁾

See Table 1

Maximum Inlet and Outlet (Casing) Pressures⁽¹⁾

1500 psig / 103 bar

Maximum Emergency (Design Casing Pressure)⁽¹⁾

1500 psig / 103 bar

Maximum Operating Differential Pressure⁽¹⁾

Main Valve: 1500 psid / 103 bar d

Pilot (Between loading pressure in pilot and loading sense pressure): 1233 psid / 85.0 bar d

Set Pressure Ranges

See Table 2

Minimum Differential Pressures⁽¹⁾

TYPE	MAIN VALVE BODY SIZE		MINIMUM DIFFERENTIAL			
			For 90% Capacity		For 100% Capacity	
	NPS	DN	psid	bar d	psid	bar d
EZH	1	25	15.2	1.1	15.7	1.1
	2	50	12.0	0.83	13.8	0.95
	3	80	10.6	0.73	12.8	0.88
	4	100	15.8	1.1	16.4	1.1
	6, 8, 12 x 6	150, 200, 300 x 150	----	----	14.0	0.97

Pressure Registration

External

Pilot Connections

1/4 NPT

Temperature Capabilities⁽¹⁾

Nitrile (NBR) Version:

-20 to 180°F / -29 to 82°C

Fluorocarbon (FKM) Version:

0 to 180°F / -18 to 82°C⁽²⁾

Polyurethane (PU) Version:

NPS 1, 2, 6, 8, 12 x 6 / DN 25, 50, 150, 200,

300 x 150 Sizes:

-22 to 180°F / -30 to 82°C

NPS 3 to 4 / DN 80 to 100 Sizes:

-4 to 180°F / -20 to 82°C

Option

Travel Indicator

1. The pressure/temperature limits in this Instructional Manual and any applicable standard or code limitation should not be exceeded.

2. Type PRX Fluorocarbon (FKM) elastomer is limited to 0°F / -18°C.

Table 1. Main Valve Body Sizes, End Connection Styles and Body Ratings

MAIN VALVE BODY SIZE		MAIN VALVE BODY MATERIAL	END CONNECTION STYLE	STRUCTURAL DESIGN RATING	
NPS	DN			psig	bar
1 and 2	25 and 50	LCC or WCC Steel	NPT or SWE	1500	103
1, 2, 3, 4, 6, 12 x 6 and 8	25, 50, 80, 100, 150, 300 x 150 and 200	LCC or WCC Steel	CL150 RF	290	20.0
			CL300 RF	750	51.7
			CL600 RF or BWE	1500	103

Table 2. Relief Set Pressure Ranges

PILOT TYPE	RELIEF SET PRESSURE RANGE		PILOT CONTROL INFORMATION							
			Part Number	Color	Wire Diameter		Free Length		Maximum Emergency Pressure	
	psig	bar			In.	mm	In.	mm	psig	bar
PRX/182	29 to 116	2.0 to 8.0	M0255220X12	Black	0.157	4.00	2.16	55	1480	102
	73 to 290	5.0 to 20.0	M0255200X12	Gold	0.217	5.50	2.01	51		
	217 to 609	15.0 to 42.0	M0255190X12	Red	0.256	6.50	1.97	50		
PRX-AP/182	435 to 1160	30.0 to 80.0	M0273790X12	Clear	0.335	8.50	3.94	100	1480	102

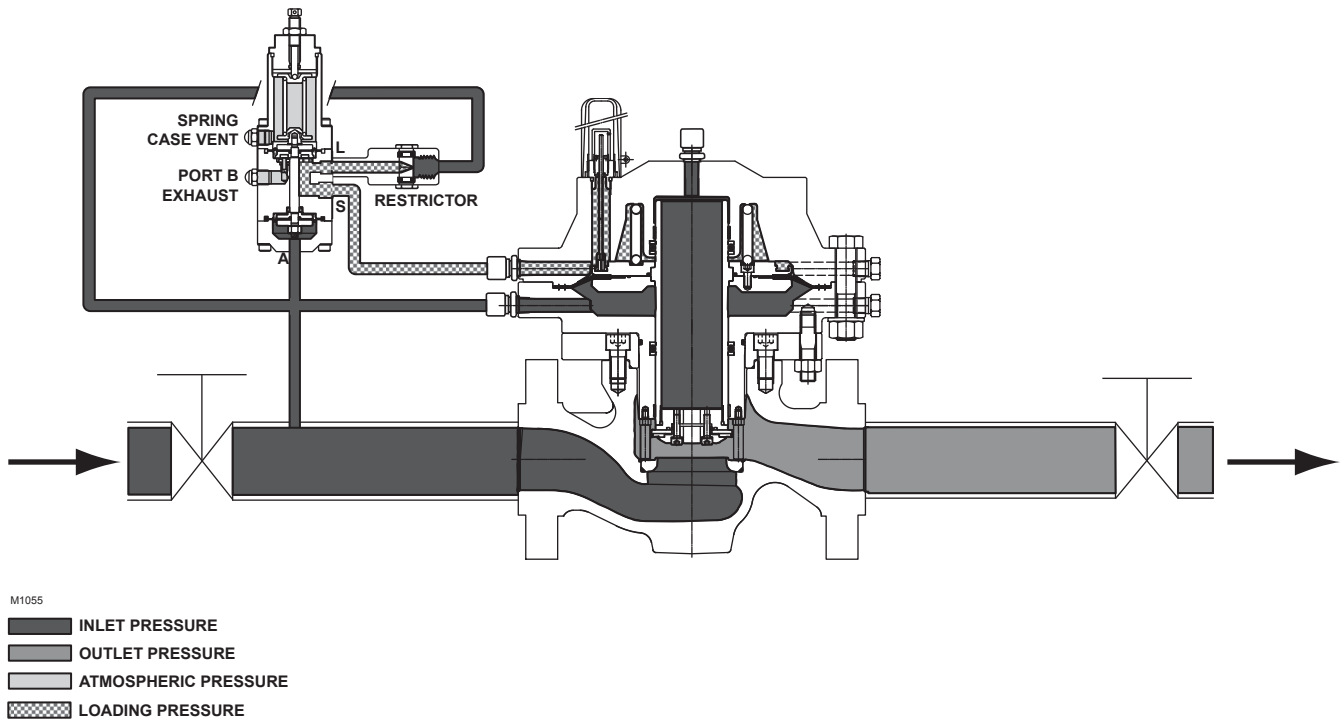

Figure 3. Type EZH with Type PRX/182 Pilot

Principle of Operation

A pressure relief valve is a throttling pressure control device that opens and closes to ensure the inlet pressure does not rise above a predetermined pressure. Fisher™ relief valves cannot be used as ASME safety relief valves. A backpressure regulator is a device that controls and responds to changes in the upstream pressure. It functions the same as a relief valve in that it opens on increasing upstream pressure.

As long as the inlet pressure is below the set pressure, the pilot control spring keeps the pilot valve plug closed. Inlet pressure passes through the restrictor and registers as loading pressure on the main valve diaphragm chamber. Force from the main spring, in addition to pilot loading pressure, provide loading pressure to keep the main valve diaphragm and plug assembly tightly shut off. When the inlet pressure rises above the set pressure, the pressure on the pilot diaphragm overcomes the pilot control spring and opens the pilot valve plug. The pilot then exhausts the loading pressure from the main valve diaphragm chamber. The pilot continuously exhausts gas when the inlet pressure is above the set pressure. The inlet pressure unbalance overcomes the main spring force and opens the diaphragm and plug assembly.

As the inlet pressure drops below the set pressure, the pilot control spring closes the pilot valve plug and the exhaust to atmosphere stops. Force from the main spring, along

with pilot loading pressure, pushes the diaphragm and plug assembly onto the knife-edged seat, producing tight shutoff.

Installation



WARNING

Personal injury, equipment damage or leakage due to escaping gas or bursting of pressure-containing parts may result if the Type EZH is installed where its capabilities can be exceeded or where conditions exceed any ratings of the adjacent piping or connections. To avoid this, install a Type EZH relief valve or backpressure regulator where:

- Service conditions are within unit capabilities (including those in the Specifications section)
- Service conditions are within applicable codes, regulations or standards

Additionally, physical damage to the relief valve or backpressure regulator could break the pilot off the main valve, causing personal injury and property damage due to escaping gas. To avoid such injury or damage, install the unit in a safe location.

Type EZH Relief

1. Only personnel qualified through training and experience should install, operate and maintain a relief valve or backpressure regulator. Before installation, make sure that there is no damage to or debris in the main valve body or pilot. Also, make sure that all tubing and piping are clean and unobstructed.



CAUTION

When installing Type EZH trim in an existing Fisher™ E-body, damage can result if flow is not in the correct direction. Look at the body web to confirm that flow is in the correct direction—up through the center of the cage and down through the cage slots. Change the existing flow arrow if necessary.

After assembly, check for shutoff and leakage to atmosphere.

2. A Type EZH relief valve or backpressure regulator may be installed in any orientation, as long as flow through it matches the direction of the arrow on the main valve body.
3. Apply pipe compound to the external pipeline threads before installing a relief valve or backpressure regulator with threaded NPT end connections. Use gaskets between pipeline and relief valve or backpressure regulator flanges when installing a relief valve or backpressure regulator with flanged end connections. When installing butt weld end connections, remove trim before welding and make sure to use approved welding practices. Use approved piping procedures when installing the relief valve or backpressure regulator.



WARNING

When used in relief valve service, the Type EZH main valve and pilot both exhaust gas. In hazardous or flammable gas service, personal injury, death or property damage may occur due to fire or explosion of vented gas that has accumulated. To prevent such injury or damage, provide piping or tubing to vent the gas to a safe location. The exhaust piping must be designed and installed to guard against excessive flow restriction. This piping must be protected against condensation or debris that could clog it.

For safety during shutdown, vent valves are required immediately upstream and downstream of the main valve on a backpressure or bypass installation.

4. If system operation during maintenance is required, install isolating and vent valves as needed.
5. For the Type PRX/182 pilot, if the vent assembly (key 12, Figure 7) remains in the pilot body (key 1, Figure 7), then it must be pointed down if possible or otherwise protected.

If the exhaust is to be piped to the main valve exhaust or remotely vented, remove the vent assembly and install tubing or piping into the 1/4 NPT pilot exhaust connection. Protect the open end of the exhaust pipe by installing a screened vent cap.

6. The Type PRX/182 pilot spring case vent (key 12, Figure 7) must be kept open to atmospheric pressure. Protect the vent assembly from icing, moisture or debris that may cause blockage, as required. To change the vent orientation, twist the vent assembly in the spring case.
7. The Type PRX pilot connections are 1/4 NPT. Connect the inlet control (sense) line from the “A” port, Figure 6 (key 47) on the bottom of the PRX Series pilot to a straight run of pipe 6 to 10 pipe diameters from the relief valve or backpressure regulator inlet as shown in Figure 3 using 3/8 in. / 9.5 mm or larger outside diameter tubing. If such a distance is not practical, connect the control line away from elbows, swages, nipples or any area where abnormal flow velocities occur.

Startup and Shutdown



CAUTION

If pressure is introduced first to the main valve before the pilot, the main valve may go wide-open and subject the downstream system to full inlet pressure.

Note

The maximum inlet pressure for specific constructions are given in Specifications section. Use a pressure gauge to monitor inlet pressure during startup.

Relief Installation (Figure 6)

Startup

1. Close vent valve (not shown).
2. Slowly open block valve and hand valve, if installed.
3. Adjust the pilot as needed.

Shutdown

1. Close block valve and hand valve, if installed.
2. Slowly open vent valve (not shown).

Backpressure Installation

Startup

1. Close upstream and downstream vent valves (not shown).
2. Slowly open upstream block valve first and then slowly open downstream block valve.

3. Adjust the pilot as needed. If the pilot is not piped downstream, make sure the pilot exhaust is pointed in the correct direction.

Shutdown

1. Close upstream block valve first and then close the downstream block valve.
2. Open downstream and upstream vent valves (not shown).

Pilot Adjustment

The adjustment of setpoint (Figure 7), is performed by means of the pilot adjusting screw, which varies the compression of the control spring. Adjustment is performed while the relief valve or backpressure regulator is in operation with the aid of a pressure gauge to monitor upstream pressure.

Loosen the Type PRX pilot locknut and turn the adjusting screw slowly clockwise to increase set pressure and counterclockwise to decrease set pressure. Use a pressure gauge to monitor the set pressure until the desired opening pressure is reached. When the desired setpoint adjustment is completed and verified, tighten the locknut to lock the adjusting screw in position.



WARNING

Avoid personal injury or damage to property from sudden release of pressure or uncontrolled gas or other process fluid. Before starting to disassemble, carefully release all pressures according to the appropriate shutdown procedure. Use a gauge to monitor relief (inlet) pressure while releasing it.



CAUTION

Use proper lifting techniques, when lifting the upper and lower actuator casings (keys 11 and 5) off the Type EZH body (key 1). The actuator assembly weighs more than 100 lbs / 45 kg.

Customer cannot use another type of eyebolt in the regulator. Only Emerson parts can be used to repair the unit.

Eye bolts are installed to aid in the handling and installation of the Regulator Assembly only. Do not attempt to lift more weight than the regulator with these eye bolts.

Maintenance

Relief valve or backpressure regulator parts are subject to normal wear and must be inspected periodically and replaced as necessary. Due to the care Emerson takes in meeting all manufacturing requirements (heat treating, dimensional tolerances, etc.), use only replacement parts manufactured or furnished by Emerson. Also when lubrication is required, use a good quality lubricant and sparingly coat the recommended parts.

The frequency of inspection and replacement depends upon the severity of service conditions and upon applicable codes, government regulations and company standards.

Use Torque Specifications (Table 3) for proper torque values.

Polyurethane (PU) Disk Conversion

To convert Type EZH Relief units to a Polyurethane (PU) disk from a Nitrile (NBR) or Fluorocarbon (FKM) disk, the user will need to order three parts: disk retainer (key 31), disk holder assembly (key 30) and seat ring (key 2). Please contact your local Sales Office with any questions about parts selection.

Main Valve and Actuator Maintenance

Disk Maintenance

NPS 1 through 3 / DN 25 through 80 (Refer to Figure 4)

1. Remove nuts (key 26).
2. Carefully lift the upper actuator casing and lower actuator casing assembly (keys 11 and 5) off the body (key 1).
3. Remove the hex socket cap screws (key 33) and lock washers (key 32). Lift off the disk holder assembly (key 30) and disk retainer (key 31).
4. Remove the O-ring (key 29). Inspect the O-ring for damage or wear and replace if necessary. Lightly lubricate O-ring before placing in the sleeve adaptor (key 27).
5. Remove the cage (key 3), seat ring (key 2) and O-ring (key 34). Inspect the O-ring for damage or wear and replace if necessary. Lightly lubricate O-ring before placing in the body (key 1).
6. Set the seat ring (key 2) back in the body (key 1) with the curved side down and the seat edge up. Place the cage (key 3) on top of seat ring. The cage will engage the step on the seat ring.
7. Place the disk holder assembly (key 30) and disk retainer (key 31) on the sleeve adaptor (key 27).
8. Insert the lock washers (key 32) and hex socket cap screws (key 33) and tighten.
9. Carefully lift the upper actuator casing and lower actuator casing assembly (keys 11 and 5) and place on the body (key 1). Secure with stud bolts and nuts (keys 24 and 26).

Type EZH Relief

Table 3. Torque Specifications and Tool Recommendations

PART NAME			BODY SIZE				
			NPS 1 / DN 25	NPS 2 / DN 50	NPS 3 / DN 80	NPS 4 / DN 100	NPS 6, 8 and 12 x 16 / DN 150, 200 and 300 x 150
Hex Head Cap Screw (key 6)	Tool Size		13/16 in. or 21 mm	3/4 in. or 19 mm	15/16 in. or 24 mm	1-1/8 in. or 29 mm	19 mm Allen
	Torque	Ft-lbs	50 to 60	50 to 60	70 to 95	140 to 155	374 to 414
		N•m	68 to 81	68 to 81	95 to 129	190 to 210	507 to 561
Allen Head Screw (key 16)	Tool Size		4 mm	5 mm	5 mm	6 mm	6 mm
	Torque	Ft-lbs	4.2 to 5.8	4.2 to 5.8	4.2 to 5.8	8.3 to 9.6	17.7 to 19.8
		N•m	5.6 to 7.9	5.6 to 7.9	5.6 to 7.9	11 to 13	24 to 27
Hex Head Cap Screw (keys 21 and 39)	Tool Size		19 mm	24 mm	32 mm	41 mm	41 mm
	Torque	Ft-lbs	50 to 55	130 to 150	250 to 270	280 to 310	483 to 497
		N•m	68 to 75	176 to 203	339 to 366	380 to 420	655 to 675
Stud Bolts (key 24)	Tool Size		3/4 in.	3/4 in.	1-1/8 in.	----	----
	Torque	Ft-lbs	50 to 70	50 to 70	100 to 120		221 to 244
		N•m	68 to 95	68 to 95	136 to 163		299 to 331
Hex Head Nut (key 26)	Tool Size		3/4 in. or 19 mm	3/4 in. or 19 mm	1-1/4 in. or 32 mm	----	30 mm
	Torque	Ft-lbs	45 to 50	45 to 50	80 to 95		140 to 160
		N•m	61 to 68	61 to 68	108 to 129		190 to 220
Allen Head Screw (key 33)	Tool Size		3 mm	4 mm	5 mm	5 mm	5 mm
	Torque	Ft-lbs	2.5 to 3.3	4.2 to 5	6.7 to 8.3	6.7 to 8.3	6.7 to 8.3
		N•m	3.4 to 4.5	5.6 to 6.8	9 to 11	9 to 11	9 to 11
Allen Screws (keys 68 and 74)	Tool Size		----	----	----	4 mm	4 mm
	Torque	Ft-lbs				3	3
		N•m				4	4
Hex Head Cap Screw (key 77)	Tool Size		----	----	----	20 mm	30 mm
	Torque	Ft-lbs				90 to 110	221 to 244
		N•m				122 to 149	299 to 331

Disk Maintenance

NPS 4, 6, 8, 12 x 6 / DN 100, 150, 200, 300 x 150
(Refer to Figure 4)

1. If present, remove travel indicator assembly by unscrewing the travel indicator fitting (key 141), then pull out the stem (key 139). Please see the Travel Indicator Maintenance section for the proper maintenance procedure.
2. Remove cap screws (key 77).
3. Carefully lift the cap (key 70) off the upper actuator casing (key 11) and unscrew an eye bolt (key 35) from the cap (key 70).
4. Loosen captured screws (key 68) until free to spin.
5. Remove the O-ring (key 69). Inspect the O-ring for damage or wear and replace if necessary. Lubricate O-ring before placing inside the cap (key 70).
6. Loosen captured screws (key 68) until free to spin.
7. Fit eye bolt (key 35) into the upper spring seat (key 73) threaded hole.

8. Carefully remove the sleeve assembly from the sleeve guide (key 61) using the eye bolt (key 35).

Note

The sleeve assembly may be oriented upside down for ease of maintenance, but care should be taken not to drop small components into the sleeve assembly.

9. Remove socket head cap screws (key 33) and lock washers (key 32).
10. Lift off the disk retainer (key 31) and disk holder assembly (key 30).
11. Remove the O-ring (key 29). Inspect the O-ring for damage or wear, replace if necessary. Lightly lubricate O-ring before placing the sleeve adaptor (key 27).
12. Place disk holder assembly (key 30) onto disk retainer (key 31).
13. Place disk retainer (key 31) with the disk holder assembly (key 30) into sleeve adaptor (key 27) and align screw holes.

14. Place lock washer (key 32) onto the screws (key 33).
15. Screw together the disk retainer assembly into the sleeve adaptor (key 27).
16. Lubricate the sleeve (key 14).
17. Carefully insert the sleeve assembly into the sleeve guide (key 61) utilizing eye bolt (key 35). Align sleeve utilizing the socket hex cap screw (key 74) as a guide.

Note

The key 9 O-rings may need to be removed and stretched by hand in order for the sleeve assembly to have sufficient clearance to slide back into the sleeve guide.

18. Screw captured screws (key 68) to affix the sleeve system. Place O-ring (key 69) on cap (key 70).
19. Remove eye bolt (key 35) from upper spring seat (key 73) threaded hole.
20. Carefully place the cap (key 70) on the upper actuator casing (key 11).
21. Lubricate cap screws (key 77) and attach cap (key 70) to the upper casing using cap screws (key 77).

Note

Rotate the cap (key 70) such that the outer holes for sensing lines are in line with upper casing holes for sensing lines. To validate the alignment and before attaching cap, check that travel indicator is aligned on the cap and on the upper actuator casing.

22. Mount O-ring (key 75) on the space between the cap (key 70) and the upper actuator casing (key 11).
23. Screw the eye bolts (key 35) on the cap (key 70).
24. If present, set the stem (key 139) through the casing hole and tap it into the groove in the diaphragm plate (key 18). Slide the travel indicator fitting (key 141) over the stem and tighten to the cap (key 70).

Intermediate Flange O-ring Maintenance

NPS 1, 2, 3, 6, 8, 12 x 6 / DN 25, 50, 80, 150, 200, 300 x 150

1. Remove nuts (key 26).
2. Carefully lift the upper actuator casing and lower actuator casing assemblies (keys 11 and 5) off the body (key 1).
3. Remove cap screws (key 6).
4. Lift off intermediate flange (key 25).
5. Remove O-ring (key 7). Inspect the O-ring for damage or wear and replace if necessary. Lightly lubricate O-ring before placing in the body (key 1).
6. Place the intermediate flange (key 25) on the body, make sure to position the stud bolt (key 24) holes on the outsides of the body (key 1). Secure with cap screws (key 6).

7. Carefully lift upper actuator casing and lower actuator casing assemblies (keys 11 and 5) and position it in the body (key 1).
8. Screw in stud bolts and nuts (keys 24 and 26).

Actuator Assembly Maintenance

NPS 1 through 3 / DN 25 through 80 (Refer to Figure 4)

1. Make a mark on the upper actuator casing (key 11), lower actuator casing (key 5), intermediate flange (key 25) and body (key 1) to indicate proper alignment when reassembling the product.
2. Remove travel indicator assembly (keys 138, 139, 140, 141, 142B, 143, 144, 145, 160 and 192), if present, by loosening the travel indicator fitting (key 141) and lifting out the travel indicator assembly.
3. Loosen out the hex nuts (key 23) and remove the washers (key 22) and the cap screws (key 21). Remove all the short bolts first, then evenly remove the two long bolts (key 39), indicated with (LB) on the head and brackets (key 35). Make sure to balance the upper actuator casing while removing the spring tension. Carefully lift the upper actuator casing (key 11) off the lower actuator casing (key 5). Remove spring (key 13).
4. Remove the socket head cap screws (key 16). Lift off the diaphragm (key 20) and the inlet plate (key 18). Remove O-rings (keys 15 and 17). Inspect the diaphragm and O-rings for damage and wear and replace if necessary.
5. Inspect the upper actuator casing (key 11), O-ring (key 9), anti-friction split rings (key 8) and anti-friction ring (key 4) for damage or wear. If damage, remove the O-ring and split rings and replace with new parts. Lightly lubricate the O-ring and split rings. Place the split rings in the body first, then slide the O-ring between the split rings. Lubricate and reinstall the anti-friction ring (key 4).
6. Remove hex nuts (key 26) from the stud bolts (key 24). Lift off the lower actuator casing (key 5). Remove the hex socket cap screws (key 33) and spring lock washers (key 32). Lift off the disk holder assembly (key 30) and disk retainer (key 31).
7. Slide the sleeve (key 14) out of the lower actuator casing (key 5) and slide the outlet plate (key 19) off the sleeve. Check the sleeve for scratches, burrs or other damage and replace if necessary.
8. Inspect the lower actuator casing (key 5), O-rings (keys 9 and 62), anti-friction split rings (key 8) and anti-friction rings (key 4) for damage or wear. If damaged, remove the O-ring and split rings and replace with new parts. Lightly lubricate the O-ring body first, then slide the O-ring (key 9) between the split rings. Lubricate and mount O-ring (key 62) outside of the lower actuator casing (key 5).
9. Slide the outlet plate (key 19) onto the sleeve (key 14) and slide the sleeve into the lower actuator casing (key 5). Place the disk holder (key 30) and disk retainer (key 31) on the sleeve adaptor (key 27). Insert the spring lock washers (key 32) and hex socket cap screws (key 33) and tighten.

Type EZH Relief

10. Lightly lubricate the O-rings (keys 15 and 17) and the inner and outer diaphragm (key 20) edges. Place the inlet plate (key 18) and the diaphragm (key 20) on the sleeve (key 14). Make sure O-rings (keys 15 and 17) are correctly positioned. Insert and tighten the hex socket cap screws (key 16).

Note

When tightening cap screws (key 21) arranged in a circular pattern, alternate the tightening of each fastener with the fastener directly across from it using a “star” criss-cross pattern for five times, until proper specified torque is achieved. Each time around, when all screws are tightened to the required torque, the diaphragm will compress a little until the plates are in direct, metal-to-metal, contact. It will take at least five times around before this happens. Only then will the applied torque on each screw remain at the required value.

11. Carefully lift the lower actuator casing assembly (key 5) and place on the body (key 1). Make sure to match up the alignment marks. Secure with stud bolts and nuts (keys 24 and 26).
12. Lightly lubricate the spring (key 13) and place on the inlet plate (key 18).
13. Carefully place the upper actuator casing (key 11) on the lower actuator casing (key 5). Make sure to match up the alignment marks. Insert the two long bolts (key 39) 180° apart and away from flanges. Place the washers (key 22), hex nuts (key 23) and brackets (key 35) on the long bolts and evenly tighten. Using proper bolting techniques, install remaining short bolts (key 21), washers and hex nuts.
14. Place travel indicator assembly (keys 138, 139, 140, 141, 142B, 143, 144, 145, 160 and 192) in the upper actuator casing (key 11), if present and tighten the travel indicator fitting (key 141).

Actuator Assembly Maintenance NPS 4 / DN 100 (Refer to Figure 4)

1. If present, remove the travel indicator assembly by unscrewing the travel indicator fitting (key 141), then pull out the stem (key 139).
2. Remove hex head cap screws (key 21), washers (key 22) and hex nuts (key 23). Carefully lift the upper actuator casing (key 11) off the lower actuator casing (key 5). Inspect the upper actuator casing (key 11), O-rings (key 9) and anti-friction rings (key 8) for damage or wear. If damaged, remove and replace with new parts. Place the anti-friction rings in the body first, then slide the O-ring between the anti-friction rings.
3. Loosen captured screws (key 68) until free to spin. Unscrew an eyebolt (key 35) from the cap and remove the screws (key 77) to remove cap (key 70) from the

upper actuator casing (key 5). Attach an eyebolt to the upper spring seat (key 73) and lift up and remove the sleeve assembly (key 14). Lift off the diaphragm/plates assembly. Remove O-ring (key 15) and replace it as needed. Inspect diaphragm (key 20) for damage or wear; remove screws (key 16), lift off inlet plate (key 18) to replace diaphragm (key 20) and O-ring (key 17).

4. Align screw holes on the cap (key 70) to the sleeve guide screws (key 66). Remove sleeve guide (key 61) utilizing cap (key 70) to unscrew or by using a crowbar. Inspect O-rings (keys 9 and 64) for damage or wear, replace anti-friction ring (key 8) and O-ring (key 9) if necessary. Unscrew the cap screws (key 6) and on NPS 4 / DN 100 constructions, remove crush washers (key 67). Lift off lower casing (key 5). On the NPS 4 / DN 100 construction, inspect O-ring (keys 7 and 63) for damage or wear. Replace if necessary.
5. Remove cage (key 78).
6. Remove seat ring (key 2). Inspect seat ring for damage or wear. If damaged, replace with new parts.
7. Remove O-ring (key 34) from body (key 1). Inspect for damage or wear. If damaged, replace with new parts. On the NPS 8 and 12 x 6 / DN 200 and 300 x 150 constructions, the seat adaptor (key 197) and o-ring (key 198) should also be inspected for damage and replaced if damaged.
8. Lubricate O-ring (key 34) and replace into the body (key 1).
9. Place seat ring (key 2) on top of O-ring (key 34) in body with the curved side down and seat edge up.
10. Place cage (key 78) on the top of seat ring (key 2).
11. Place lower casing (key 5) on top of the body. On NPS 4 / DN 100 constructions, replace washer (key 67) with new parts. Tighten cap screws (key 6). Screw sleeve guide (key 61) into lower casing (key 5) utilizing cap (key 70) or by using crowbar.
12. Lubricate the sleeve (key 14) in the upper plate contact area and assemble the diaphragm/plates assembly on the sleeve system. Tighten screws (key 16) using a “star” criss-cross pattern for five times until proper specified torque is achieved.
13. Screw the captured screws (key 68) – already on the sleeve – to fix the diaphragm/plates assembly on the sleeve assembly. Tighten screws (key 68) using a “star” criss-cross pattern for five times until proper specified torque is achieved.
14. Lubricate lower casing (key 5) on the diaphragm contact area.
15. Carefully insert the sleeve assembly into the sleeve guide (key 61) utilizing the eye-bolts (key 35) that fits in the upper spring seat (key 73) threaded hole.

Note

The key 9 O-rings may need to be removed and stretched by hand in order for the sleeve assembly to have sufficient clearance to slide back into the sleeve guide.

16. Lubricate the diaphragm (key 20) on the upper casing contact area.
17. Lubricate and mount the O-ring (key 69) on the cap (key 70). Lubricate and mount O-rings (key 9) and anti-friction rings (key 8) inside the cap. Unscrew the eye bolts (key 35) from the upper spring seat (key 73) and carefully place the cap on the upper actuator casing (key 11). Align the travel indicator hole on the cap to the upper actuator casing travel indicator hole. Lubricate cap screws (key 77) and attach cap (key 70) to the upper casing (key 11) using cap screws (key 77). Bag diaphragm flat to lower actuator casing diaphragm flange contact area. Carefully place the upper actuator casing on the top of the lower actuator casing/trim system using a stud to guide.

Note

Rotate the upper casing such that the outer holes for sensing lines are perpendicular to gas flow and outer holes of lower casing.

18. Lubricate threads on bolts (key 21).
19. Bolt together the upper and lower actuator casings (keys 11 and 5) using cap screws (key 21), washers (key 22) and hex nuts (key 23). Tighten cap screws using a “star” criss-cross pattern for five times until proper specified torque is achieved.
20. Mount O-ring (key 75) on the cap (key 70).
21. Screw the eye-bolts (key 35) on the cap (key 70).
22. If present, set the stem (key 139) through the casing hole and tap it into the groove in the diaphragm plate (key 18). Slide the travel indicator fitting (key 141) over the stem and tighten to the cap (key 70).

Type EZH Travel Indicator Maintenance

A new and improved travel indicator has been phased in during 2013. The new version improves the O-ring stem seal to minimize leakage and extend service life. The components of the legacy and new versions are not interchangeable. If maintenance is performed on the new travel indicator, it is recommended to replace the entire travel indicator assembly with the new version. Part numbers for the assemblies are shown in the parts list. Figure 5 shows the difference between the designs. The spare parts kits will support either design. Take care to use the correct O-ring (key 142A or 142B) when performing maintenance, see parts list for the appropriate part number.

1. Remove plastic travel indicator cover (key 138).
2. Loosen travel indicator bushing (key 140) and remove it by sliding it over the travel indicator stem (key 139).
3. Remove indicator fitting (key 141) and inspect O-ring (key 143). Remove O-ring (key 142B) and back-up rings (key 160). Replace and lubricate O-ring if damaged. Pull up on the travel indicator stem (key 139) to force the spring collet (key 144) out of the diaphragm head groove. Examine these parts and the stem for wear and replace if necessary.

4. Examine the retaining ring (key 145) for wear and replace if necessary.
5. Insert the travel indicator stem (key 139) and spring collet (key 144) back into the diaphragm head groove. Replace the indicator fitting (key 141) and O-ring (key 143) and tighten with a referenced torque of 20 ft-lbs / 27.1 N•m.
6. Lubricate the O-ring (key 142B) and back-up rings (key 160, 2 required). Place one back-up ring on the stem (key 139) followed by the O-ring and then the other back-up ring. Push into groove of the indicator fitting (key 141).
7. Slide the travel indicator bushing (key 140) over the travel indicator stem (key 139) and tighten firmly in place with a torque of 3.7 ft-lbs / 5.0 N•m.
8. Replace the travel indicator cover (key 138) and tighten firmly in place.

Type PRX/182 Maintenance (Figure 7)



Always remove spring (key 7) tension before performing maintenance on this unit. To remove spring tension, loosen locknut (key 2) and back out adjusting screw (key 1) until compression is removed from the spring.

Lower Diaphragm Maintenance

1. Disconnect pilot and remove it from the line.
2. Remove machine screws (key 10) from lower cover (key 21) and the separate lower cover from the body (key 16).
3. Use a wrench to hold the stem (key 23) and break loose the stem nut (key 20). Remove the stem nut and washer (key 11).
4. Remove the diaphragm plate (key 13), diaphragm (key 14), lower diaphragm plate (key 15) and O-ring (key 18). Inspect parts for damage or wear, replace if necessary.
5. Lightly lubricate the O-ring (key 25). Place O-ring over the stem (key 23) and press it down into the body (key 16).
6. Lightly lubricate the rims of the diaphragm (key 14) and place it on top of the lower diaphragm plate (key 15). Set the diaphragm plate (key 13) on the diaphragm (key 14).
7. Lightly lubricate the O-ring (key 18) and place it in the lower cover (key 21).
8. Place the washer (key 11) and stem nut (key 20) on the stem (key 23) and tighten. *If also performing Upper Case Maintenance, skip to step 2 of the Upper Case Maintenance section.*
9. Insert washers (key 11) and machine screws (key 10) in the lower cover (key 21) and tighten uniformly to ensure proper seal.

Type EZH Relief

Upper Diaphragm Maintenance

1. Disconnect pilot and remove it from the line.
2. Loosen locknut (key 2) and back out adjusting screw (key 1) until compression is removed from the spring. Remove cap (key 3).
3. Lift the upper spring seat (key 6), spring (key 7) and O-ring (key 4) out of the spring case (key 8). Inspect O-ring and replace if necessary.
4. Remove the machine screws (key 10) and the washers (key 11), separate the spring case (key 8) from the body (key 16) and lift the lower spring seat (key 9) away from upper diaphragm nut (key 26). Use a wrench to hold stem (key 23) securely while removing the upper diaphragm nut.
5. Remove remaining loose components: washer (key 11), upper diaphragm plate (key 13), diaphragm (key 14), disk holder (key 22) and O-ring (key 18). Inspect diaphragm and O-ring for damage or wear and replace if necessary.
6. Remove orifice (key 19) and O-ring (key 17). Inspect the parts for damage or wear and replace if necessary. Lightly lubricate the O-ring and place in the body (key 16). Install the orifice.
7. Set the disk holder (key 22) in the body (key 16).
8. Lightly lubricate the rims of the diaphragm plate (key 14). Position the diaphragm convolution facing down, make sure that the diaphragm is not deformed and is properly installed. Take the diaphragm (key 14) and place it in the body (key 16) on top of the disk holder (key 22).
9. Set the upper diaphragm plate (key 13) on top of the diaphragm (key 14).
10. Place washer (key 11) and stem nut (key 26) on the stem (key 23) and tighten using a wrench to hold the stem.
11. Place the upper spring seat (key 9) on the upper diaphragm nut (key 26) and mount the spring case (key 8) on top of the body (key 24) and the diaphragm (key 14).
12. Place washers (key 11) and uniformly tighten the machine screws (key 10) to hold the body (key 24) and spring case (key 8) together.
13. Install spring (key 7) and upper spring seat (key 6) on top of the lower spring seat (key 9) inside the spring case (key 8). Install Cap (key 3).
14. Screw in adjusting screw (key 1) at desired spring compression and use the lock nut (key 2) to lock the adjusting screws position.

Parts Ordering

Each Type EZH relief valve or backpressure regulator is assigned a serial number, which can be found on the nameplate. Refer to the serial number when contacting your local Sales Office for technical information or when ordering parts.

When ordering replacement parts, reference the key number of each needed part as found in the following parts list. Separate kit containing all recommended spare parts is available.

Parts Lists

Type EZH Main Valve (Figure 4)

Key	Description	Part Number
Disk Parts Kits		
	NPS 1, 2 and 3 / DN 25, 50 and 80 Bodies (include keys 29, 30, 32, 33, 34 and 62)	
	NPS 4, 6, 8 and 12 x 6 / DN 100, DN 150, 200 and 300 x 150 (include keys 29, 30, 32, 33, 69, 71 and 75)	
	NPS 1 / DN 25 Body	
	Nitrile (NBR) and Fluorocarbon (FKM)	REZH1X00N12
	Fluorocarbon (FKM)	REZH1X00F12
	Polyurethane (PU)	REZH1X00P12
	NPS 2 / DN 50 Body	
	Nitrile (NBR) and Fluorocarbon (FKM)	REZH2X00N12
	Fluorocarbon (FKM)	REZH2X00F12
	Polyurethane (PU)	REZH2X00P12
	NPS 3 / DN 80 Body	
	Nitrile (NBR) and Fluorocarbon (FKM)	REZH3X00N12
	Fluorocarbon (FKM)	REZH3X00F12
	Polyurethane (PU)	REZH3X00P12
	NPS 4 / DN 100 Body	
	Nitrile (NBR) and Fluorocarbon (FKM)	REZH4X00N12
	Fluorocarbon (FKM)	REZH4X00F12
	Polyurethane (PU)	REZH4X00P12
	NPS 6, 8 and 12 x 6 / DN 150, 200 and 300 x 150 Bodies	
	Nitrile (NBR)	REZH6X00N12
	Fluorocarbon (FKM)	REZH6X00F12
	Polyurethane (PU)	REZH6X00P12
Full Repair Kits		
	NPS 1, 2 and 3 / DN 25, 50 and 80 Bodies (include keys 4, 7, 8, 9, 15, 17, 20, 28, 29, 30, 32, 33, 34, 62, 142B and 143)	
	NPS 4 / DN 100 Body (include keys 7, 8, 9, 15, 17, 20, 29, 30, 32, 33, 34, 63, 64, 67, 69, 71, 75, 142B and 143)	
	NPS 6, 8 and 12 x 6 / DN 150, 200 and 300 x 150 (include keys 7, 8, 9, 15, 17, 20, 29, 30, 32, 33, 34, 64, 69, 71, 75, 142, 143, 160 and 198)	
	NPS 1 / DN 25 Body	
	Nitrile (NBR) and Fluorocarbon (FKM)	REZH1X00N22
	Fluorocarbon (FKM)	REZH1X00F22
	Polyurethane (PU)	REZH1X00P22
	NPS 2 / DN 50 Body	
	Nitrile (NBR) and Fluorocarbon (FKM)	REZH2X00N22
	Fluorocarbon (FKM)	REZH2X00F22
	Polyurethane (PU)	REZH2X00P22
	NPS 3 / DN 80 Body	
	Nitrile (NBR) and Fluorocarbon (FKM)	REZH3X00N22
	Fluorocarbon (FKM)	REZH3X00F22
	Polyurethane (PU)	REZH3X00P22
	NPS 4 / DN 100 Body	
	Nitrile (NBR) and Fluorocarbon (FKM)	REZH4X00N22
	Fluorocarbon (FKM)	REZH4X00F22
	Polyurethane (PU)	REZH4X00P22
	NPS 6 and 12 x 6 / DN 150 and 300 x 150 Bodies	
	Nitrile (NBR)	REZH6X00N22
	Fluorocarbon (FKM)	REZH6X00F22
	Polyurethane (PU)	REZH6X00P22
	NPS 8 / DN 200 Body	
	Nitrile (NBR)	REZH8X00N22
	Fluorocarbon (FKM)	REZH8X00F22
	Polyurethane (PU)	REZH8X00P22

Type EZH Main Valve (continued)

Key	Description	Part Number	Key	Description	Part Number
1	Body	See Table 4	8*	Anti-Friction Rings, Polytetrafluoroethylene (PTFE) (4 required)	
2	Seat Ring, Stainless steel			NPS 1 / DN 25 Body	M0194530X12
	NPS 1 / DN 25 Body	ERAA04303A0		NPS 2 / DN 50 Body	M0194690X12
	NPS 2 / DN 50 Body	ERAA04296A0		NPS 3 / DN 80 Body	M0192170X12
	NPS 3 / DN 80 Body	ERAA05563A0		NPS 4 / DN 100 Body (8 required)	M0194830X12
	NPS 4 / DN 100 Body	ERAA10213A0		NPS 6, 12 x 6 and 8 / DN 150, 300 x 150 and 200 Bodies (10 required)	ERAA00645A0
	NPS 6, 12 x 6 and 8 / DN 150, 300 x 150 and 200 Bodies	ERAA23465A0	9*	O-ring, Fluorocarbon (FKM) (2 required)	
3 ⁽¹⁾	Cage, Stainless steel			NPS 1 / DN 25 Body	M6020019X12
	NPS 1 / DN 25 Body	GE31405X012		NPS 2 / DN 50 Body	M6020029X12
	NPS 2 / DN 50 Body	GE37679X012		NPS 3 / DN 80 Body	M6020036X12
	NPS 3 / DN 80 Body	GE38018X012		NPS 4 / DN 100 Body, (3 required)	M6020044X12
	NPS 4 / DN 100, Standard	M0303260X12		NPS 6, 12 x 6 and 8 / DN 150, 300 x 15 and 200 Bodies (4 required)	
	NPS 6, 12 x 6 and 8 / DN 150, 300 x 150 and 200 Bodies, Standard	ERAA00860A0		Nitrile (NBR)	ERCA00979A1
4*	Anti-Friction Ring, Polytetrafluoroethylene (PTFE) (2 required)			Fluorocarbon (FKM)	ERCA00979A0
	NPS 1 / DN 25 Body	M0274090X12	10	Pipe Plug	
	NPS 2 / DN 50 Body	M0272760X12		NPS 1, 2 and 3 / DN 25, 50 and 80 (5 required)	1A767524662
	NPS 3 / DN 80 Body	M0272810X12		NPS 4, 6, 12 x 6 and 8 / DN 100, 150, 300 x 150 and 200 Bodies (6 required)	1A767524662
5	Actuator Lower Casing, Carbon steel		11	Actuator Upper Casing, Carbon steel	
	NPS 1 / DN 25 Body	M0296970X12		NPS 1 / DN 25 Body	M0297220X12
	NPS 2 / DN 50 Body	M0295830X12		NPS 2 / DN 50 Body	M0296950X12
	NPS 3 / DN 80 Body	GE44397X012		NPS 3 / DN 80 Body	GE44420X012
	NPS 4 / DN 100 Body	M0300770X12		NPS 4 / DN 100 Body	M0300760X12
	NPS 6, 12 x 6 and 8 / DN 150, 300 x 150 and 200 Bodies	ERAA09114A0		NPS 6, 12 x 6 and 8 / DN 150, 300 x 150 and 200 Bodies	ERAA00360A0
6	Cap Screws, Zinc-plated steel		13	Spring, Carbon steel	
	NPS 1 / DN 25 Body (4 required)	M4691008X12		NPS 1 / DN 25 Body	M0194590X12
	NPS 2 / DN 50 Body (8 required)	GE11386X012		NPS 2 / DN 50 Body	M0191440X12
	NPS 3 / DN 80 Body (4 required)	GE11387X022		NPS 3 / DN 80 Body	M0192240X12
	NPS 4 / DN 100 Body (8 required)	M4691020X42		NPS 4, 6, 12 x 6 and 8 / DN 100, 150, 300 x 150 and 200 Bodies ⁽²⁾	-----
	NPS 6 and 12 x 6 / DN 150 and 300 x 150 Bodies (12 required)	ERCA01349A0	14	Sleeve, Steel	
	NPS 8 / DN 200 Body (8 required)	ERCA01350A0		NPS 1 / DN 25 Body	M0274230X12
7*	O-ring			NPS 2 / DN 50 Body	M0272600X12
	NPS 1 / DN 25 Body			NPS 3 / DN 80 Body	M0276310X12
	Nitrile (NBR)	19B2838X012		NPS 4, 6, 12 x 6 and 8 / DN 100, 150, 300 x 150 and 200 Bodies ⁽²⁾	-----
	Fluorocarbon (FKM)	19B2838X022	15*	O-ring, Fluorocarbon (FKM)	
	NPS 2 / DN 50 Body			NPS 1 / DN 25 Body	M6020021X12
	Nitrile (NBR)	18B2124X012		NPS 2 / DN 50 Body	M6020095X12
	Fluorocarbon (FKM)	18B2124X022		NPS 3 / DN 80 Body	M6020073X12
	NPS 3 / DN 80 Body			NPS 4 / DN 100 Body	M6020170X12
	Nitrile (NBR)	18B8514X012		NPS 6, 12 x 6 and 8 / DN 150, 300 x 150 and 200 Bodies	
	Fluorocarbon (FKM)	18B8514X022		Nitrile (NBR)	ERCA00971A2
	NPS 4 / DN 100 Body			Fluorocarbon (FKM)	ERCA00971A1
	Fluorocarbon (FKM)	M6020169X12			
	NPS 6 and 12 x 6 / DN 150 and 300 x 150 Bodies				
	Nitrile (NBR)	ERCA00970A0			
	Fluorocarbon (FKM)	ERCA00970A1			
	NPS 8 / DN 200 Body				
	Nitrile (NBR)	1P5585X0023			
	Fluorocarbon (FKM)	1P5585X0032			

*Recommended Spare Part

- When retrofitting a Type EZH with pins with the new cage, it is also necessary to order the Seat Ring.
- Parts are not orderable. See Table 6 for sleeve assembly if it needs to be replaced.

Type EZH Relief

Type EZH Main Valve (continued)

Key	Description	Part Number	Key	Description	Part Number
16	Socket Head Cap Screw, Zinc-plated steel NPS 1 / DN 25 Body (6 required) NPS 2 / DN 50 Body (6 required) NPS 3 / DN 80 Body (12 required) NPS 4 / DN 100 Body (8 required) NPS 6, 12 x 6 and 8 / DN 150, 300 x 150 and 200 Bodies (16 required)	M5011005X12 M5011014X12 M5011140X12 M5011157X12 M5011157X12	23	Hex Nut, Zinc-plated carbon steel NPS 1 / DN 25 Body (16 required) NPS 2 / DN 50 Body (16 required) NPS 3 / DN 80 Body (16 required) NPS 4 / DN 100 Body (16 required) NPS 6, 12 x 6 and 8 / DN 150, 300 x 150 and 200 Bodies (28 required)	1A341224122 1A343324122 ERCA01576A0 M46566X012 M5002014X12
17*	O-ring, Fluorocarbon (FKM) NPS 1 / DN 25 Body NPS 2 / DN 50 Body NPS 3 / DN 80 Body NPS 4 / DN 100 Body NPS 6, 12 x 6 and 8 / DN 150, 300 x 150 and 200 Bodies Nitrile (NBR) Fluorocarbon (FKM)	M6020120X12 M6020096X12 M6020127X12 M6020097X12 ERCA00961A0 ERCA00961A1	24	Continuous Thread Stud Bolt, Zinc-plated steel NPS 1 / DN 25 Body (4 required) NPS 2 / DN 50 Body (6 required) NPS 3 / DN 80 Body (6 required) NPS 6, 12 x 6 and 8 / DN 150, 300 x 150 and 200 Bodies (12 required)	M4693002X12 GE00808X042 M4693003X22 ERCA01475A0
18	Inlet Plate, Carbon steel NPS 1 / DN 25 Body NPS 2 / DN 50 Body NPS 3 / DN 80 Body NPS 4 / DN 100 Body NPS 6, 12 x 6 and 8 / DN 150, 300 x 150 and 200 Bodies	M0194440X12 M0194620X12 M0192080X12 M0300020X12 ERAA00363A0	25	Intermediate Flange, Carbon steel NPS 1 / DN 25 Body NPS 2 / DN 50 Body NPS 3 / DN 80 Body NPS 6 / DN 150 Body NPS 12 x 6 / DN 300 x 150 Body NPS 8 / DN 200 Body	M0297240X12 M0295800X12 GE44403X012 ERAA00365A0 ERAA00365A0 ERAA00774A0
19	Outlet Plate, Carbon steel NPS 1 / DN 25 Body NPS 2 / DN 50 Body NPS 3 / DN 80 Body NPS 4 / DN 100 Body NPS 6, 12 x 6 and 8 / DN 150, 300 x 150 and 200 Bodies	M0194480X12 M0194660X12 M0192120X12 M0300030X12 ERAA00364A0	26	Hex Nut, Steel NPS 1 / DN 25 Body (4 required) NPS 2 / DN 50 Body (6 required) NPS 3 / DN 80 Body (6 required) NPS 6, 12 x 6 and 8 / DN 150, 300 x 150 and 200 Bodies (12 required)	1A341224122 1A341224122 M4692004X12 M5002011X12
20*	Diaphragm, Nitrile (NBR) NPS 1 / DN 25 Body NPS 2 / DN 50 Body NPS 3 / DN 80 Body NPS 4 / DN 100 Body NPS 6, 12 x 6 and 8 / DN 150, 300 x 150 and 200 Bodies	M0194450X12 M0194630X12 M0192090X12 M0194750X12 ERAA00648A0	27	Sleeve Adaptor, Carbon steel NPS 1 / DN 25 Body NPS 2 / DN 50 Body NPS 3 / DN 80 Body NPS 4, 6, 12 x 6 and 8 / DN 100, 150, 300 x 150 and 200 Bodies ⁽²⁾	M0274250X12 M0272570X12 M0276340X12 -----
21	Cap Screw, Zinc-plated steel NPS 1 / DN 25 Body (14 required) NPS 2 / DN 50 Body (14 required) NPS 3 / DN 80 Body (14 required) NPS 4 / DN 100 Body (16 required) NPS 6, 12 x 6 and 8 / DN 150, 300 x 150 and 200 Bodies (28 required)	1A361524052 1P1477X0012 GF05679X012 M4691022X12 M5007193X12	28*	O-ring, Fluorocarbon (FKM) NPS 1 / DN 25 Body NPS 2 / DN 50 Body NPS 3 / DN 80 Body	M6020144X12 M6020079X12 M6020151X12
22	Plain Washer, Steel NPS 1 / DN 25 Body (16 required) NPS 2 / DN 50 Body (16 required) NPS 3 / DN 80 Body (16 required) NPS 4 / DN 100 Body (16 required) NPS 6, 12 x 6 and 8 / DN 150, 300 x 150 and 200 Bodies (28 required)	M5001007X12 M5001009X12 M5001012X12 M5001015X12 M5001015X12	29*	O-ring NPS 1 / DN 25, Fluorocarbon (FKM) NPS 2 / DN 50, Fluorocarbon (FKM) NPS 3 / DN 80, Fluorocarbon (FKM) NPS 4 / DN 100 Nitrilecarbon (FKM) NPS 6, 12 x 6 and 8 / DN 150, 300 x 150 and 200 Bodies Nitrile (NBR) Fluorocarbon (FKM)	M6020143X12 M6020112X12 M6020147X12 M6020171X12 M6020171X12 ERAA09517A0 ERAA09517A1

*Recommended Spare Part

2. Parts are not orderable. See Table 6 for sleeve assembly if it needs to be replaced.

Type EZH Main Valve (continued)

Key	Description	Part Number	Key	Description	Part Number
30*	Disk Holder Assembly		34*	O-ring	
	NPS 1 / DN 25 Body			NPS 1 / DN 25 Body	
	Nitrile (NBR)	M0280900X12		Nitrile (NBR)	M6010099X12
	Fluorocarbon (FKM)	M0282130X12		Fluorocarbon (FKM)	M6020065X12
	Polyurethane (PU)	ERAA07132A0		NPS 2 / DN 50 Body	
	NPS 2 / DN 50 Body			Nitrile (NBR)	M6010109X12
	Nitrile (NBR)	M0280910X12		Fluorocarbon (FKM)	M6020159X12
	Fluorocarbon (FKM)	M0282140X12		NPS 3 / DN 80 Body	
	Polyurethane (PU)	ERAA07133A0		Nitrile (NBR)	M6010247X12
	NPS 3 / DN 80 Body			Fluorocarbon (FKM)	M6020165X12
	Nitrile (NBR)	M0280920X12		NPS 4 / DN 100 Body	
	Fluorocarbon (FKM)	M0282150X12		Nitrile (NBR)	M6010126X12
	Polyurethane (PU)	ERAA10096A0		Fluorocarbon (FKM)	M6020127X12
	NPS 4 / DN 100 Body			NPS 6, 12 x 6 and 8 / DN 150, 300 x 150 and	
	Nitrile (NBR)	M0299090X12		200 Bodies	
	Fluorocarbon (FKM)	M0300120X12		Nitrile (NBR)	1H8623X0023
	Polyurethane (PU)	ERAA11680A0		Fluorocarbon (FKM)	1H8623X0022
	NPS 6, 12 x 6 and 8 / DN 150, 300 x 150 and		35	Bracket or Eyebolt (2 required)	
	200 Bodies			NPS 1 / DN 25 Body - Bracket	M0220960X12
	Nitrile (NBR)	ERAA23677A0		NPS 2 / DN 50 Body - Bracket	M0278570X12
	Fluorocarbon (FKM)	ERAA23677A1		NPS 3 / DN 80 Body - Eyebolt	M5095001X12
	Polyurethane (PU)	ERAA24008A0		NPS 4 / DN 100 Body - Eyebolt	M5095001X12
31	Disk Retainer			NPS 6, 12 x 6 and 8 / DN 150, 300 x 150 and	
	Nitrile (NBR) and Fluorocarbon (FKM)			200 Bodies - Eyebolt	M5040006X12
	NPS 1 / DN 25 Body	M0274160X12	36	Nameplate	-----
	NPS 2 / DN 50 Body	M0272750X12	37	Drive Screw, Stainless steel (3 required)	-----
	NPS 3 / DN 80 Body	M0276250X12	38	Travel Indicator Plug	
	NPS 4 / DN 100 Body	M0300100X12		NPS 1, 2 and 3 / DN 25, 50 and 80 Bodies	M0297680X12
	NPS 6, 12 x 6 and 8 / DN 150, 300 x 150 and			NPS 4 / DN 100 Body	M0303680X12
	200 Bodies	-----		NPS 6, 12 x 6 and 8 / DN 150, 300 x 150 and	
	Polyurethane (PU)			200 Bodies	ERAA00990A0
	NPS 1 / DN 25 Body	ERAA04846A0	39	Long Bolt, Zinc-plated steel (2 required)	
	NPS 2 / DN 50 Body	ERAA04789A0		NPS 1 / DN 25 Body	GE07221X012
	NPS 3 / DN 80 Body	ERAA05023A0		NPS 2 / DN 50 Body	M4691014X12
	NPS 4 / DN 100 Body	ERAA08206A0		NPS 3 / DN 80 Body	ERCA01574A0
	NPS 6, 12 x 6 and 8 / DN 150, 300 x 150 and		43	Caution/Warning Label, Aluminum	-----
	200 Bodies	ERAA23464A0	44	Adjusting Screw Cap, Plastic	24B1301X012
32*	Lock Washer, Stainless steel		59	Flow Arrow, Stainless steel	-----
	NPS 1 / DN 25 Body (1 required)	M5077005X12	60	Protective Cap, Plastic (2 required)	
	NPS 2 / DN 50 Body (2 required)	M5077004X12		NPS 1, 2 and 3 / DN 25, 50 and 80 Bodies Only	
	NPS 3 / DN 80 Body (3 required)	M5077001X12		NPS 1 / DN 25 Body	T13659T0092
	NPS 4 / DN 100 Body (4 required)	M5001004X12		NPS 2 / DN 50 Body	T13659T0072
	NPS 6, 12 x 6 and 8 / DN 150, 300 x 150 and			NPS 3 / DN 80 Body	T13659T0102
	200 Bodies (8 required)	ERAA26743A0	61	Sleeve Guide, Steel	
33	Socket Head Cap Screw, Zinc-plated steel			NPS 4 / DN 100 Body Only	M0300360X12
	NPS 1 / DN 25 Body (1 required)	M5011131X12		NPS 6, 12 x 6 and 8 / DN 150, 300 x 150 and	
	NPS 2 / DN 50 Body (2 required)	M5011006X12		200 Bodies	ERAA00850A0
	NPS 3 / DN 80 Body (3 required)	M5011017X12	62*	O-ring	
	NPS 4 / DN 100 Body (4 required)	M5011018X12		NPS 1 / DN 25 Body, Nitrile (NBR)	M6020082X12
	NPS 6, 12 x 6 and 8 / DN 150, 300 x 150 and			NPS 2 / DN 50 Body, Fluorocarbon (FKM)	M6010110X12
	200 Bodies (8 required)	M5011018X12		NPS 3 / DN 80 Body, Nitrile (NBR)	M6020094X12

*Recommended Spare Part

Type EZH Relief

Type EZH Main Valve (continued)

Key	Description	Part Number	Key	Description	Part Number
63*	O-ring Fluorocarbon (FKM) (for NPS 4 / DN 100 only)	M6020172X12	83	Ball Bearing, Steel (2 required) NPS 4, 6, 12 x 6 and 8 / DN 100, 150, 300 x 150 and 200 Bodies Only ⁽³⁾	-----
64*	O-ring Fluorocarbon (FKM) (NPS 4 / DN 100) NPS 6, 12 x 6 and 8 / DN 150, 300 x 150 and 200 Bodies Nitrile (NBR) Fluorocarbon (FKM)	M6020139X12 ERCA00966A2 ERCA00966A0	138	Travel Indicator Cover, Plastic NPS 1 / DN 25 Body NPS 2 / DN 50 Body NPS 3 / DN 80 Body NPS 4, 6, 12 x 6 and 8 / DN 100, 150, 300 x 150 and 200 Bodies	M0194580X12 M0196770X12 M0194870X12 M0210910X12
66	Socket Head Set Screw, Zinc-plated steel NPS 4 / DN 100 Body Only (8 required) NPS 6, 12 x 6 and 8 / DN 150, 300 x 150 and 200 Bodies (8 required)	M5021047X12 M5021047X12	139	Travel Indicator Stem, Stainless steel NPS 1 / DN 25 Body NPS 2 / DN 50 Body NPS 3 / DN 80 Body NPS 4 / DN 100 Body NPS 6, 12 x 6 and 8 / DN 150, 300 x 150 and 200 Bodies	ERSA01803A0 ERSA01801A0 ERSA01803A0 ERSA02571A0
67*	Crush Washer, Aluminum NPS 4 / DN 100 Body Only (8 required)	M4501738X12	140	Indicator Bushing	ERAA00912A0 ERSA02798A0
68	Captured Screw, Zinc-plated steel NPS 4 / DN 100 Body Only (8 required) NPS 6, 12 x 6 and 8 / DN 150, 300 x 150 and 200 (16 required)	M0300040X12 M0300040X12	141	Travel Indicator Fitting NPS 1, 2 and 3 / DN 25, 50 and 80 Bodies NPS 4 / DN 100 NPS 6, 12 x 6 and 8 / DN 150, 300 x 150 and 200 Bodies	ERSA02569A0 ERSA01824A0 ERAA00962A0
69*	O-ring, NPS 4 / DN 100, Fluorocarbon (FKM) NPS 6, 12 x 6 and 8 / DN 150, 300 x 150 and 200 Bodies Nitrile (NBR) Fluorocarbon (FKM)	M6020149X12 ERCA00967A0 ERCA00967A1	142A*	O-ring Nitrile (NBR) Fluorocarbon (FKM)	M6010001X12 M6020066X12
70	Cap, Carbon steel NPS 4 / DN 100 Body NPS 6, 12 x 6 and 8 / DN 150, 300 x 150 and 200 Bodies, EZH Series	M0299980X12 ERAA11794A0	142B*	O-ring Nitrile (NBR) Fluorocarbon (FKM)	1H2926X0032 1H2926X0022
71*	O-ring Fluorocarbon (FKM)	M6020175X12	143*	O-ring, Fluorocarbon (FKM)	M6020005X12
72	Locking Nut, Steel NPS 4, 6, 12 x 6 and 8 / DN 100, 150, 300 x 150 and 200 Bodies Only ⁽³⁾	-----	144	Spring Collet, Carbon steel	M0192180X12
73	Upper Spring Seat, Carbon steel NPS 4, 6, 12 x 6 and 8 / DN 100, 150, 300 x 150 and 200 Bodies Only ⁽³⁾	-----	145	Retaining Ring	M4500325X12
74	Hex Socket Cap Screw, Zinc-plated steel NPS 4 / DN 100 Body NPS 6, 12 x 6 and 8 / DN 150, 300 x 150 and 200 Bodies	M5011135X12 M5011135X12	160*	Back-up ring, Polytetrafluoroethylene (PTFE) (2 required)	1N659106242 M0201990X12
75*	O-ring NPS 4 / DN 100 Bodies, Fluorocarbon (FKM) NPS 6, 12 x 6 and 8 / DN 150, 300 x 150 and 200 Bodies Nitrile (NBR) Fluorocarbon (FKM)	M6020117X12 ERCA00965A0 ERCA00965A1	192	Travel Indicator Scale	
77	Screw, Zinc-plated steel NPS 4 / DN 100 Body (8 required) NPS 6, 12 x 6 and 8 / DN 150, 300 x 150 and 200 Bodies (12 required)	M5009048X12 FA402451X12	196	Washer (24 required) NPS 6, 12 x 6 and 8 / DN 150, 300 x 150 and 200 Bodies	M5001011X12
82	Lower Spring Seat, Carbon steel NPS 4, 6, 12 x 6 and 8 / DN 100, 150, 300 x 150 and 200 Bodies Only ⁽³⁾	-----	197	Seat Adaptor NPS 12 x 6 / DN 300 x 150 Body NPS 8 / DN 200 Body	ERAA23256A0 ERAA00887A0
			198	O-ring NPS 12 x 6 / DN 300 x 150 Nitrile (NBR) Fluorocarbon (FKM) NPS 8 / DN 200 Nitrile (NBR) Fluorocarbon (FKM)	ERAA23247A0 ERAA23247A1 ERAA27282A1 ERAA27282A0

*Recommended Spare Part
3. Included also in sleeve subassembly.

PRX Series Mounting Parts

Key	Description	Part Number
45	Bleed Orifice, Brass	GE01698X012
46	Pipe Nipple, Stainless steel	GE13860X012
47	Pipe Nipple, Carbon steel	1C488226232
48	Tube Elbow	-----
49	Male Tube Connector (5 required)	-----
51	Pipe Cross	1L3719X0012
52	Tubing, Stainless steel	-----

PRX Series Pilot

Key	Description	Part Number
	Parts Kits	
	Without Disk (includes keys 4, 5, 14, 17, 18, 25 and 28)	
	Nitrile (NBR)	RPRX00X0N12
	Fluorocarbon (FKM)	RPRX00X0F12
	With Disk (includes keys 4,5,14, 17, 18, 22, 25 and 28)	
	Nitrile (NBR)	RPRX00X0N22
	Fluorocarbon (FKM)	RPRX00X0F22
1	Adjusting Screw, Stainless steel	M0253340X12
2	Locknut	M5036008X12
3	Cap, Steel	M0253350X12
4*	Spring Case O-ring (2 required for Type PRX-AP/182)	
	Nitrile (NBR)	M6010178X12
	Fluorocarbon (FKM)	M6020112X12
5*	O-ring	
	Nitrile (NBR)	M6010005X12
	Fluorocarbon (FKM)	M6020001X12
6	Upper Spring Seat, Stainless steel	M0253360X12
7	Spring	See Table 2
8	Spring Case, Steel	M0298540X12
9	Lower Spring Seat, Stainless steel	M0253380X12
10	Machine Screw, Zinc-plated steel (12 required)	M5011018X12
11	Washer (14 required)	M5055001X12
12	Filter	M4500367X12
13	Diaphragm Plate, Stainless steel (2 required)	M0253390X12
14*	Diaphragm	
	Nitrile (NBR)	GG05785X012
	Fluorocarbon (FKM)	GG05785X022
15	Diaphragm Plate, Stainless steel (2 required)	M0253410X12
16	Body, Steel	M0253310X12

Key	Description	Part Number
17*	Orifice O-ring Nitrile (NBR) Fluorocarbon (FKM)	M6010003X12 M6020126X12
18*	Lower Cover O-ring (2 required) Nitrile (NBR) Fluorocarbon (FKM)	M6010098X12 M6020132X12
19	Seat, Stainless steel	M0253440X12
20	Nut, Steel	M5002004X12
21	Lower Cover, Steel	M0298600X12
22*	Disk Holder Nitrile (NBR) Fluorocarbon (FKM)	ERAA11220A0 M0279950X12
23	Stem, Steel	M0253430X12
24	Nameplate	-----
25*	Stem O-ring Nitrile (NBR) Fluorocarbon (FKM)	M6010223X12 M6020133X12
26	Upper Diaphragm Nut	M5028005X12
27	Damper Adjusting Screw with Hole, Stainless steel	M0253480X12
28*	Restrictor/Damper O-ring (2 required)	M6020054X12
29	Nameplate	-----
31	Nameplate Screw	M5061001X12
33	Restrictor Plug (Type PRX/182)	M4500328X12
34	Pipe Plug (Type PRX/182) (2 required)	M0257920X12
35	Spring Barrel Extension for AP, Steel	M0274100X12

*Recommended Spare Part

Type EZH Relief

Table 4. Key 1, Type EZH Main Valve Body Part Numbers

BODY SIZE		BODY MATERIAL	END CONNECTION STYLE	BODY STYLE	
NPS	DN			Standard or Tapped Inlet (Pilot Supply)	Tapped Inlet and Tapped Outlet
1	25	WCC Steel	NPT	GE11581X012	-----
			SWE	GE11440X012	
			CL150 RF	GE11583X012	14B5623X032
			CL300 RF	GE11607X012	14B5623X042
			CL600 RF	GE11608X012	14B5623X052
			SCH 40 BWE	GE11610X012	-----
			SCH 80 BWE	GE11611X012	
PN 16-40 RF	GE13625X012				
2	50	WCC Steel	NPT	GE10588X012	-----
			SWE	GE10682X012	
			CL150 RF	GE10676X012	14B5834X032
			CL300 RF	GE10678X012	14B5834X042
			CL600 RF	GE10679X012	14B5834X052
			SCH 40 BWE	GE10680X012	-----
			SCH 80 BWE	GE10681X012	
PN 16-40	GE12898X012 ⁽¹⁾				
3	80	WCC Steel	CL150 RF	GE10699X012	14B5835X032
			CL300 RF	GE10700X012	14B5835X042
			CL600 RF	GE10701X012	14B5835X052
			SCH 40 BWE	GE10702X012	-----
			SCH 80 BWE	GE10703X012	
			PN 25-40	GE13594X012 ⁽¹⁾	
4 ⁽²⁾	100	WCC Steel	CL150 RF	GE10835X012	14B5836X032
			CL300 RF	GE10839X012	14B5836X042
			CL600 RF	GE10842X012	14B5836X052
			SCH 40 BWE	GE10843X012	-----
			SCH 80 BWE	GE10844X012	
6	150	WCC Steel	CL150 RF	GE11447X012	24B5837X032
			CL300 RF	GE11449X012	24B5837X042
			CL600 RF	GE11451X012	24B5837X052
			SCH 40 BWE	GE11452X012	24B5837X072
12 x 6	300 x 150	WCC Steel	CL150 RF	GE19095X012	-----
			CL300 RF	GE19096X012	
			CL600 RF	GE19097X012	
			SCH 40 BWE	GE19093X012	
			SCH 80 BWE	GE19094X012	
8	200	LCC Steel	CL150 RF	-----	FA144718X12
			CL300 RF		FA144717X12
			CL600 RF		FA144716X12
			SCH 40 BWE		GE00715X012

1. Not available for Standard body.
2. Not available for Tapped Inlet (Pilot Supply) body.

Table 5. Type EZH Travel Indicator Assemblies Part Numbers⁽¹⁾

MATERIAL	NPS 1 / DN 25	NPS 2 / DN 50	NPS 3 / DN 80	NPS 4 / DN 100	NPS 6, 12 x 6 AND 8 / DN 150, 300 x 150 AND 200
Nitrile (NBR)	ERSA01539A0	ERSA01546A0	ERSA01547A0	ERSA01549A0	ERAA03686A0

1. The assemblies include keys 138, 139, 140, 141, 142B, 143, 144, 145, 160 and 192.

Table 6. EZH Series Sleeve Assembly Part Number

MATERIAL	NPS 4 / DN 100	NPS 6, 12 x 6 AND 8 / DN 150, 300 x 150 AND 200
Nitrile (NBR), Fluorocarbon (FKM) or Polyurethane (PU)	M2201052X12	ERAA03692A0

Type EZH Relief

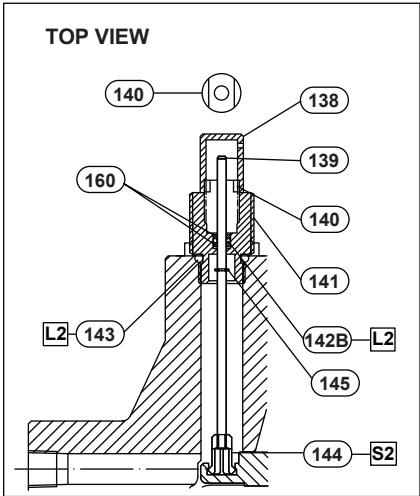
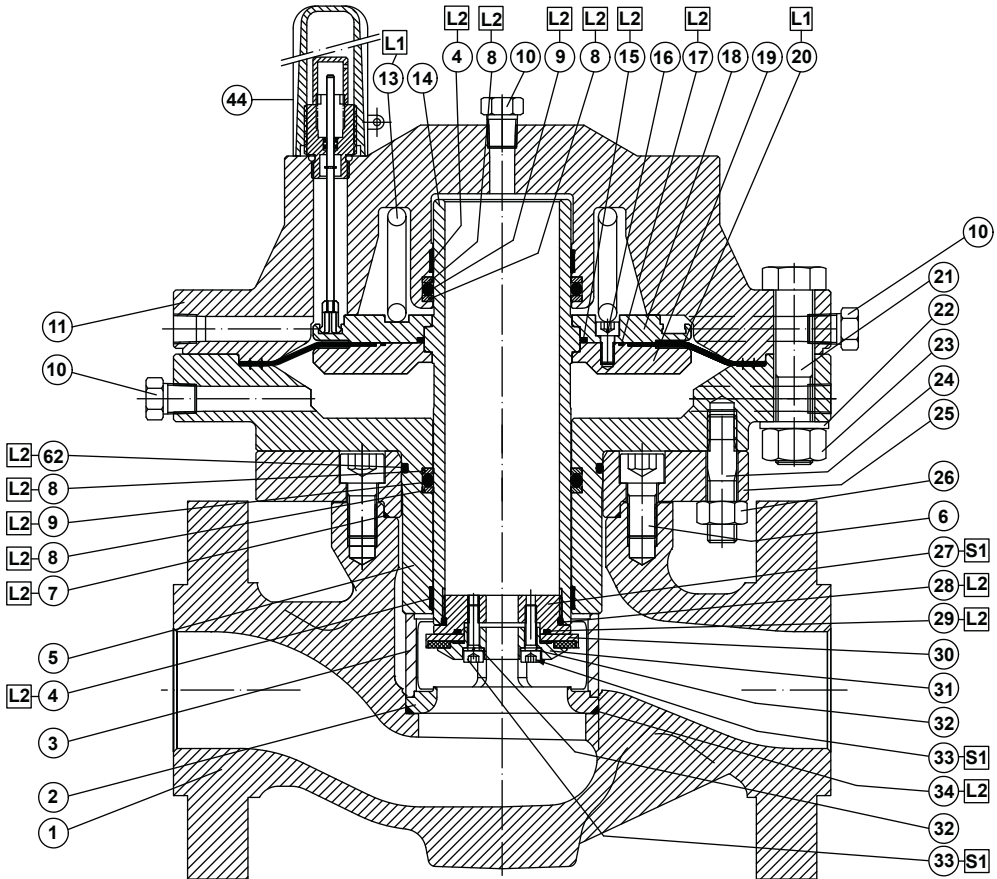

IMPROVED TRAVEL INDICATOR DETAIL

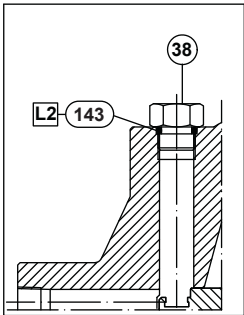

VERSION WITHOUT TRAVEL INDICATOR DETAIL

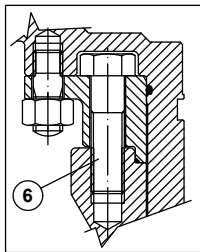

FOR NPS 1 / DN 25 EZH SERIES VERSION ONLY

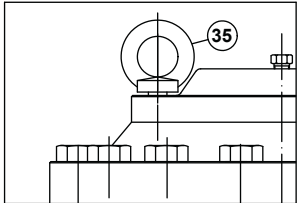

FOR NPS 3 / DN 80 EZH SERIES VERSION ONLY

NPS 1 THROUGH 3 / DN 25 THROUGH 80

GD89918_H

- APPLY LUBRICANT (L) / SEALANT (S)⁽¹⁾:
 - L1 = LITHIUM HYDROXYSTEGRATE NLGI 2 GRADE GREASE
 - L2 = SILICONE-BASED OR PTFE-BASED GREASE
 - S1 = ANAEROBIC METHACRYLATE SEALANT FOR NUTS AND BOLTS
 - S2 = ANAEROBIC METHACRYLATE SEALANT FOR THREADS

1. Lubricant and sealant must be selected such that they meet the temperature requirements.

Figure 4. Type EZH Main Valve Assembly

Type EZH Relief

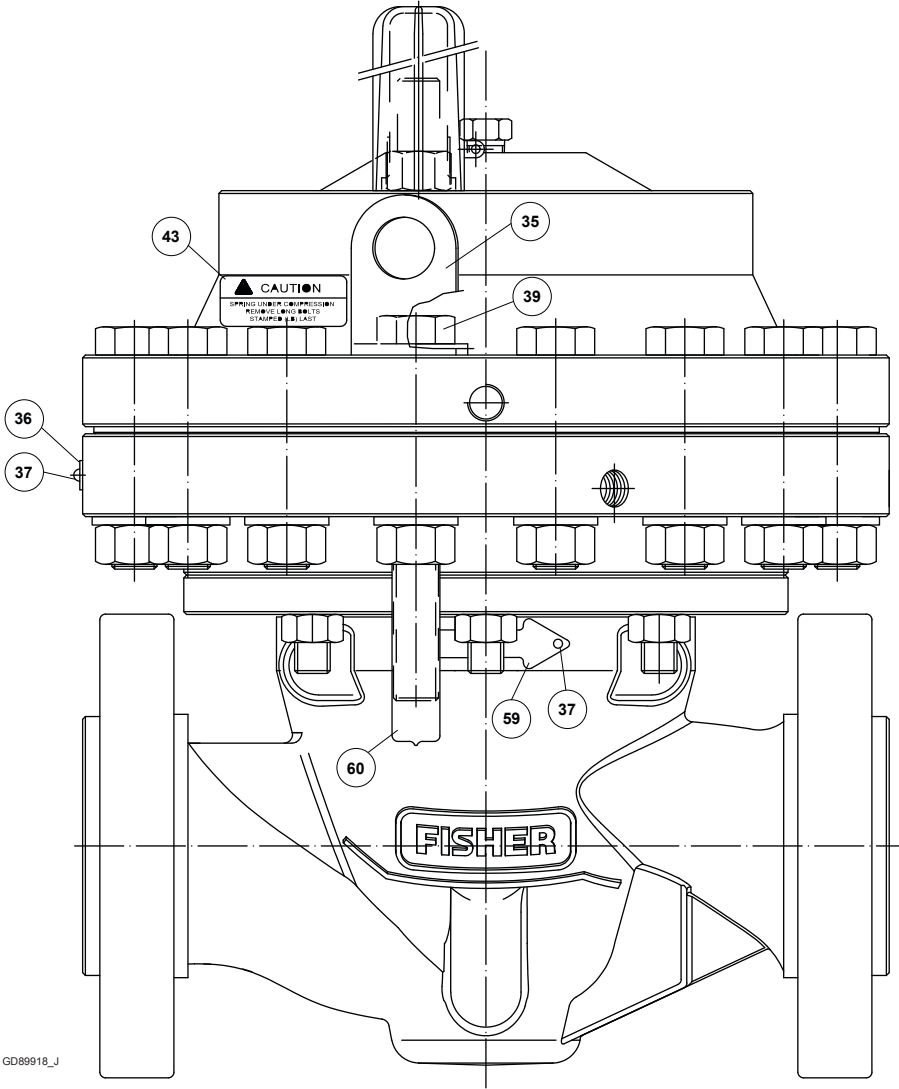

GD89918_J

NPS 1 THROUGH 3 / DN 25 THROUGH 80

Figure 4. Type EZH Main Valve Assembly (continued)

Type EZH Relief

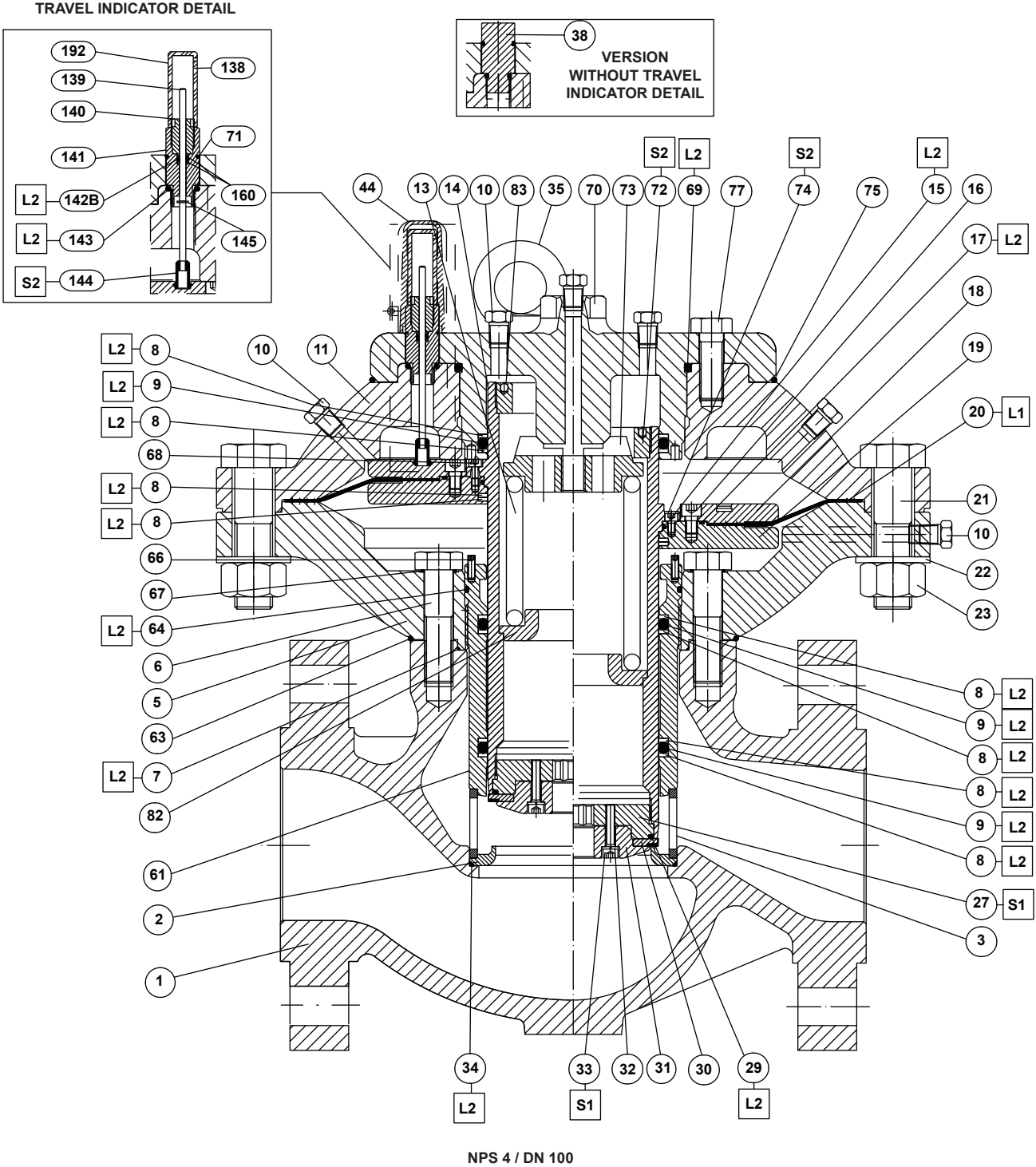

MLM1945_B

- APPLY LUBRICANT (L) / SEALANT (S)⁽¹⁾:
 - L1 = LITHIUM HYDROXYSTEGRATE NLGI 2 GRADE GREASE
 - L2 = SILICONE-BASED OR PTFE-BASED GREASE
 - S1 = ANAEROBIC METHACRYLATE SEALANT FOR NUTS AND BOLTS
 - S2 = ANAEROBIC METHACRYLATE SEALANT FOR THREADS

1. Lubricant and sealant must be selected such that they meet the temperature requirements.

Figure 4. Type EZH Main Valve Assembly (continued)

Type EZH Relief

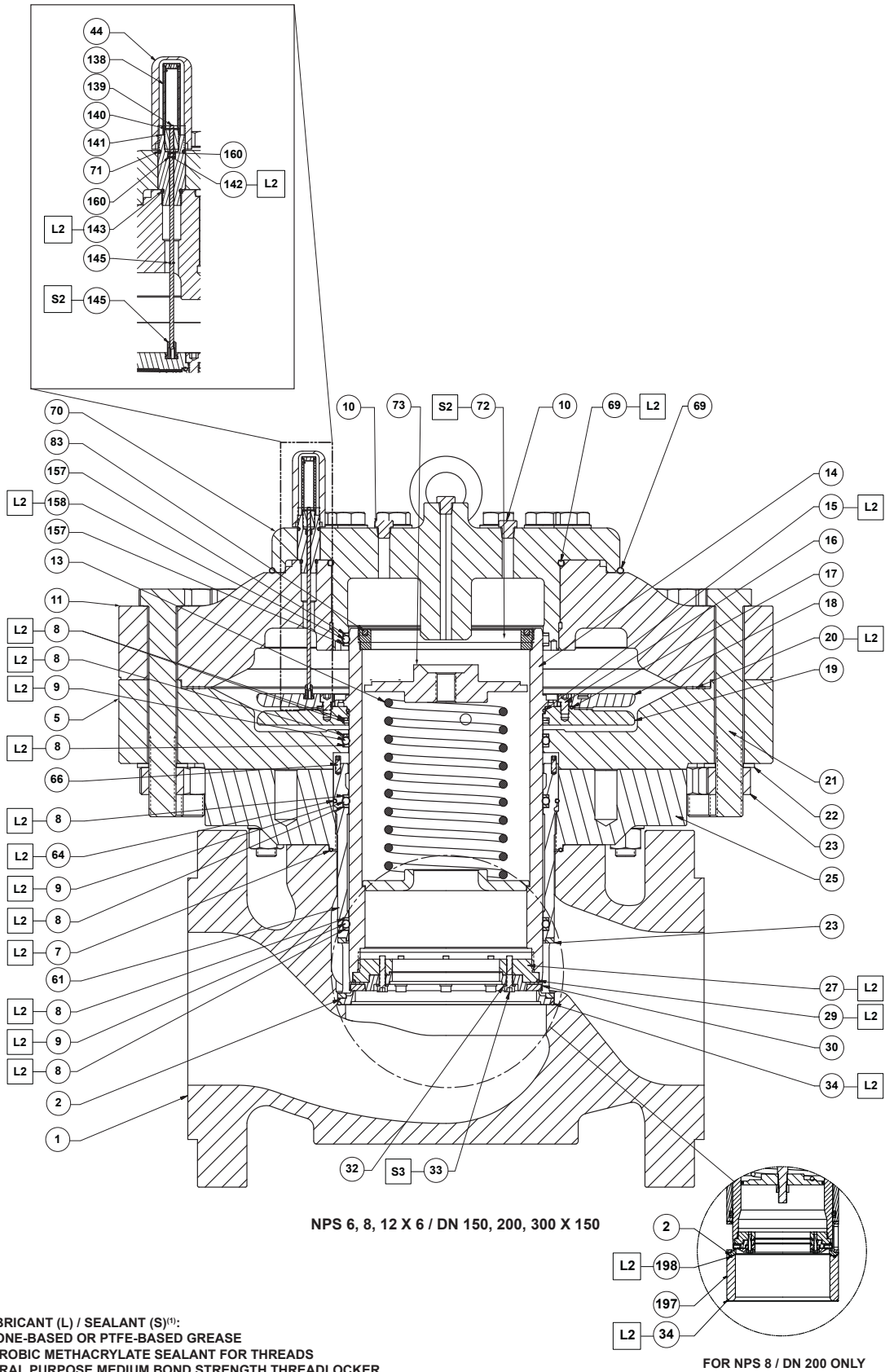

ERAA01010_AA

- APPLY LUBRICANT (L) / SEALANT (S)⁽¹⁾:
 L2 = SILICONE-BASED OR PTFE-BASED GREASE
 S2 = ANAEROBIC METHACRYLATE SEALANT FOR THREADS
 S3 = GENERAL PURPOSE MEDIUM BOND STRENGTH THREADLOCKER

1. Lubricant and sealant must be selected such that they meet the temperature requirements.

Figure 4. Type EZH Main Valve Assembly (continued)

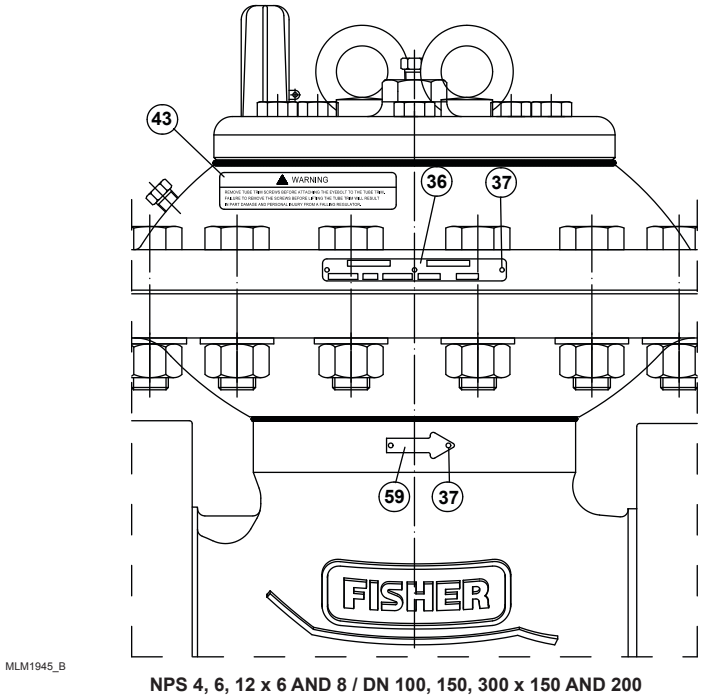
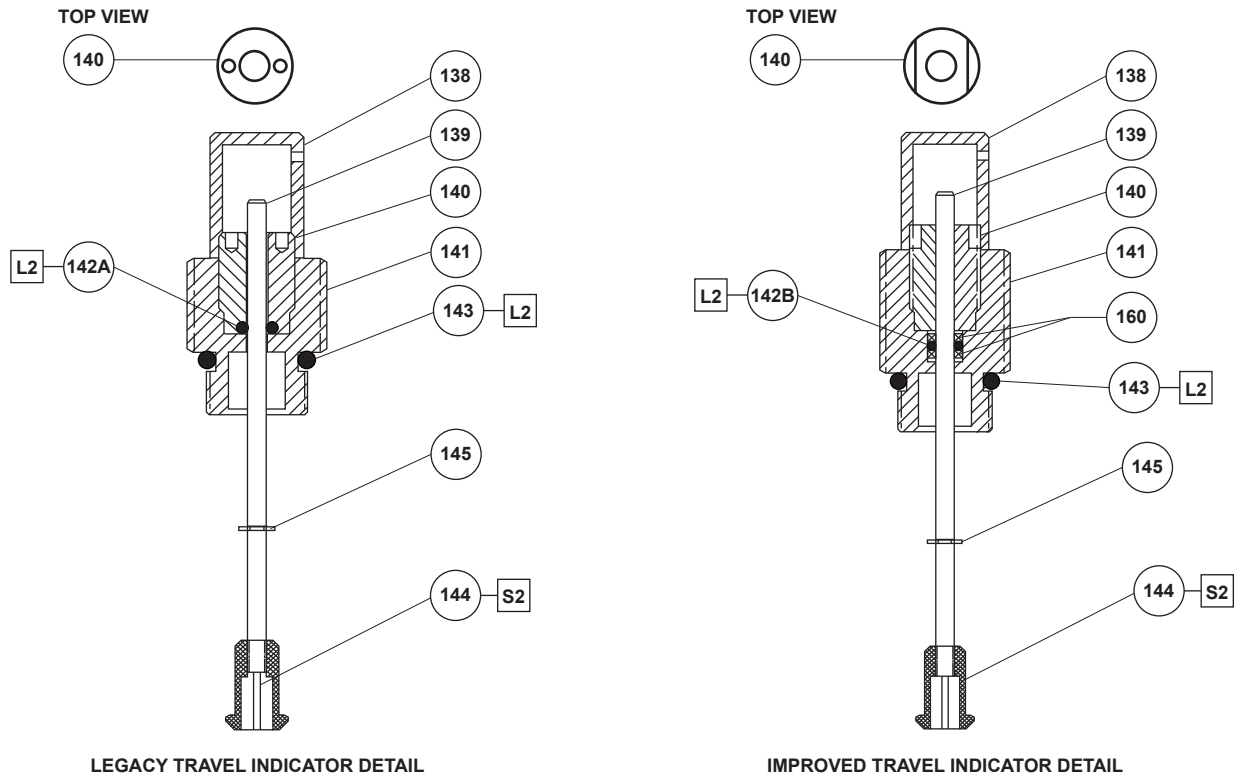

Figure 4. Type EZH Main Valve Assembly (continued)



APPLY LUBRICANT (L) / SEALANT (S)⁽¹⁾:
 L2 = SILICONE-BASED OR PTFE-BASED GREASE
 S2 = ANAEROBIC METHACRYLATE SEALANT FOR THREADS
 1. Lubricant and sealant must be selected such that they meet the temperature requirements.

Figure 5. Type EZH Travel Indicator Assembly

Type EZH Relief

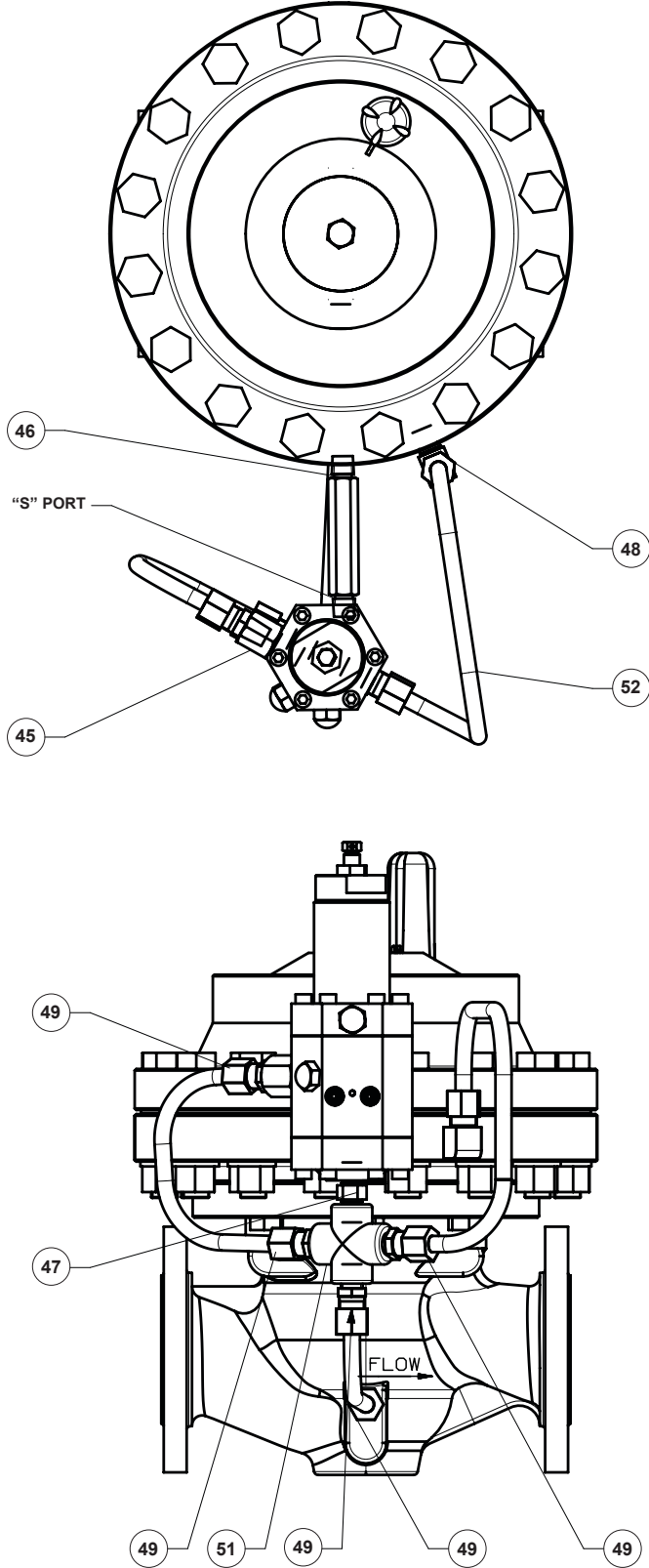
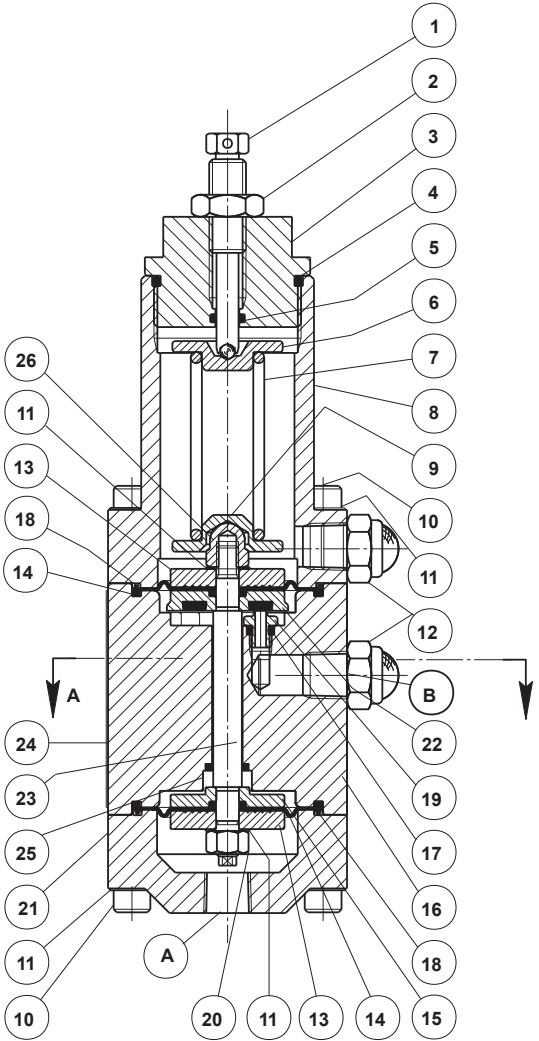
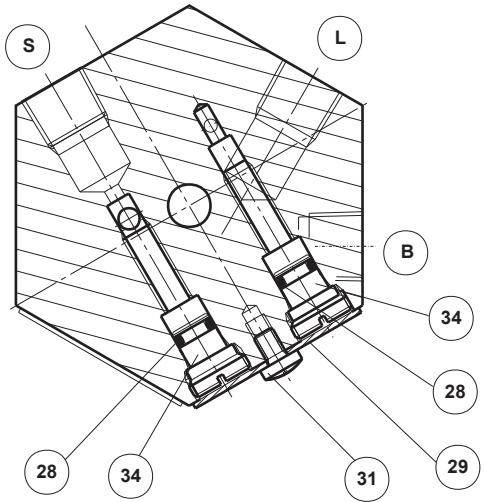

Figure 6. Type EZH Mounting Assembly



TYPE PRX/182 PILOT ASSEMBLY



SECTION A - A

Figure 7. Type PRX/182 Pilot Assemblies

Type EZH Relief

 Webadmin.Regulators@emerson.com

 Fisher.com

 Facebook.com/EmersonAutomationSolutions

 LinkedIn.com/company/emerson-automation-solutions

 Twitter.com/emr_automation

Emerson Automation Solutions

Americas

McKinney, Texas 75070 USA
T +1 800 558 5853
+1 972 548 3574

Europe

Bologna 40013, Italy
T +39 051 419 0611

Asia Pacific

Singapore 128461, Singapore
T +65 6770 8337

Middle East and Africa

Dubai, United Arab Emirates
T +971 4 811 8100

D103078X012 © 2012, 2017 Emerson Process Management Regulator Technologies, Inc. All rights reserved. 11/17.

The Emerson logo is a trademark and service mark of Emerson Electric Co. All other marks are the property of their prospective owners. Fisher™ is a mark owned by Fisher Controls International LLC, a business of Emerson Automation Solutions.

The contents of this publication are presented for information purposes only, and while effort has been made to ensure their accuracy, they are not to be construed as warranties or guarantees, express or implied, regarding the products or services described herein or their use or applicability. All sales are governed by our terms and conditions, which are available on request. We reserve the right to modify or improve the designs or specifications of our products at any time without notice.

Emerson Process Management Regulator Technologies, Inc. does not assume responsibility for the selection, use or maintenance of any product. Responsibility for proper selection, use and maintenance of any Emerson Process Management Regulator Technologies, Inc. product remains solely with the purchaser.

