

# Enhanced Sealing ES-850 and ES-950 Series Pressure/Vacuum Relief Valve (ATEX Approved)



MODEL ES-850

MODEL ES-950

Figure 1. ES-850 and ES-950 Series Pressure/Vacuum Relief Valve

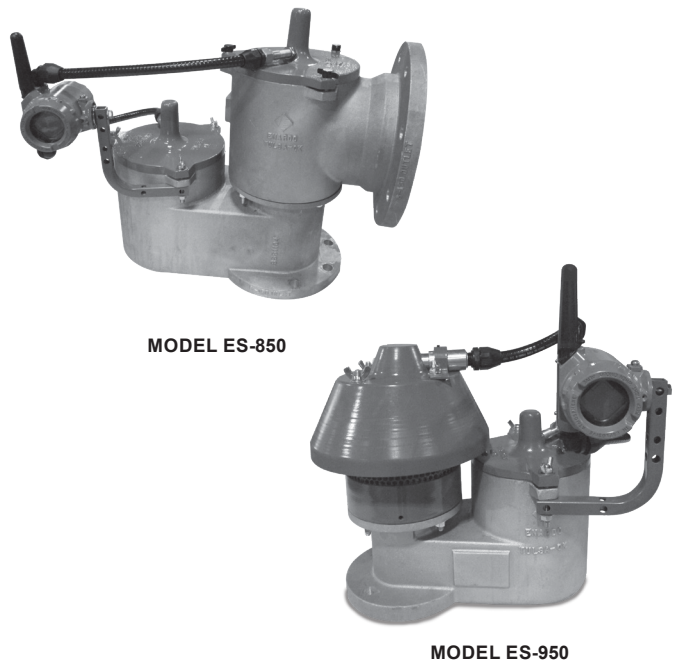

MODEL ES-850

MODEL ES-950

Figure 2. ES-850 and ES-950 Series with Smart Wireless option

North America Only

## Table of Contents

Introduction.....	2
Specifications .....	2
Product Identification and Marking .....	5
Principle of Operation .....	5
Installation .....	8
Maintenance .....	11
Adjustments.....	14
Valve Repair .....	16



## WARNING

Failure to follow these instructions or to properly install and maintain this equipment could result in an explosion, fire and/or chemical contamination causing property damage and personal injury or death.

Enardo™ pressure/vacuum relief valve must be installed, operated and maintained in accordance with federal, state and local codes, rules and regulations, and Emerson Process Management Regulator Technologies Tulsa, LLC (Emerson) instructions. These units are not designed or intended for use in mobile, high vibration or high acceleration applications.

# ES-850 and ES-950 Series

## Specifications

The Specifications section on this page provides specifications for the ES-850 and ES-950 Series pressure/vacuum relief valve. Specification is stamped on the nameplate attached to the relief valve. Refer to Product Identification and Marking section for the nameplate details.

### Available Constructions

See Figures 3 and 4

### Inlet Connection Sizes

2 through 12 in. / 50 through 300 mm

### Pressure Ranges<sup>(1)(2)</sup>

#### For sizes up to 6 in. / 150 mm

0.5 to 32 oz./sq. in.

1.0 to 55 in. w.c.

2.15 to 138 mbar

22 to 1406 mm w.c.

#### For sizes 8 in. / 200 mm and larger<sup>(3)</sup>

0.5 to 24 oz./sq. in.

1.0 to 41.5 in. w.c.

2.15 to 103 mbar

22 to 1055 mm w.c.

### Vacuum Pressure Ranges<sup>(1)(2)</sup>

#### For sizes up to 6 in. / 150 mm

0.4 to 32 oz./sq. in.

1.0 to 55 in. w.c.

1.72 to 138 mbar

17.6 to 1406 mm w.c.

### Vacuum Pressure Ranges<sup>(1)(2)</sup> (continued)

#### For sizes 8 in. / 200 mm and larger<sup>(3)</sup>

0.4 to 24 oz./sq. in.

1.0 to 41.5 in. w.c.

1.72 to 103 mbar

17.6 to 1055 mm w.c.

### Construction Materials

**Housing:** Aluminum, Stainless steel or Carbon steel

**Seat / Pallet:** 316 Stainless steel

**Pallet Seal:** Nitrile (NBR), Fluorinated Ethylene Propylene (FEP), Fluorocarbon (FKM) or Fluorosilicone (FVMQ)

**Hardware:** Zinc-plated Carbon steel or Stainless steel

**Weights:** Zinc-plated Carbon steel, Stainless steel or Lead

**Gaskets:** Nitrile (NBR), FEP, Fluorocarbon (FKM) or Fluorosilicone (FVMQ)

### Certifications

EN IEC 60079-0:2018

EN IEC 60079-11:2012

EN ISO 80079-36:2016

EN ISO 80079-37:2016

1. The pressure limits in this Instruction Manual and any applicable standard or code limitation should not be exceeded.

2. Pressure or vacuum setting has an increment of 0.5 oz./sq. in., 0.5 in. w.c. or 2.2 mbar.

3. 8, 10 and 12 in. / 200, 250 and 300 mm sizes limited to a maximum pressure relief setting of 16 oz./sq. in. / 69 mbar when a vacuum relief setting of 0.4 oz./sq. in. / 1.72 mbar is used.

**Failure to correct trouble could result in a hazardous condition. Call a qualified service person to service the unit. Installation, operation and maintenance procedures performed by unqualified person may result in improper adjustment and unsafe operation. Either condition may result in equipment damage or personal injury. Only a qualified person shall install or service the pressure/vacuum relief valve.**

## Introduction

### Scope of the Manual

This Instruction Manual provides instructions for installation, maintenance and parts ordering information for the ES-850 and ES-950 Series Pressure/Vacuum Relief Valve (PVRV).

### Product Description

#### ES-850 and ES-950 Series

The ES-850 and ES-950 Series Pressure/Vacuum Relief Valves provide protection against positive or vacuum overpressure and prevent air intake and evaporative losses of product while helping to contain odorous and potentially explosive vapors.

The ES-850 Series provides pressure and vacuum relief in applications that require hazardous vapors to be piped away rather than released into the atmosphere.

The ES-950 Series valve provides pressure and vacuum relief for normal venting requirements while maintaining a safe internal working pressure to prevent the routine expulsion of waste gas to the atmosphere.

- **Model ES-850:** Pressure/Vacuum Relief Valve — Pipe-Away
- **Model ES-851:** Top Mount Pressure or Side Mount Vacuum Relief Valve — Pipe-Away
- **Model ES-950:** Pressure/Vacuum Relief Valve — Vent-to-Atmosphere
- **Model ES-951:** Pressure Relief Valve — Vent-to-Atmosphere
- **Model ES-952:** Top Mount Vacuum Relief Valve — End-of-Line
- **Model ES-953:** Side Mount Vacuum Relief Valve

# ES-850 and ES-950 Series

Model	Inlet Size	Outlet Size	Housing Material	Pallet and Seat Material	Pallet Seal Material	Body/Seat/Lid Seal Material
ES-850	2 to 12 in.	3 to 14 in.	1 = Aluminum 4 = 316SST 5 = Carbon Steel	2 = 316SST	1 = FEP 2 = Nitrile (NBR) 3 = Fluorocarbon (FKM) 4 = Fluorosilicone (FVMQ)	1 = PTFE Body and FEP Seat/Lid 2 = Nitrile (NBR) 3 = Fluorocarbon (FKM) 4 = Fluorosilicone (FVMQ)

Pressure Units	Pressure Setting	Vacuum Units	Vacuum Setting	Weight Material	Options
z = oz./sq. in. n = in. w.c. mm = mm w.c. mb = mbar	0.5 to 32.0 oz./sq. in. 0.86 to 55.0 in. w.c. 22 to 1406 mm w.c. 2.2 to 138 mbar	z = oz./sq. in. n = in. w.c. mm = mm w.c. mb = mbar	0.5 to 32.0 oz./sq. in. 0.86 to 55.0 in. w.c. 22 to 1406 mm w.c. 2.2 to 138 mbar	C = CS ZP S = SST L = Lead	0 = No Options F = Flat Face Flange (standard for Aluminum) R = Raised Face Flange (standard for CS, SS) X = Epoxy Coating W1 = Wireless Pressure and Vacuum Monitoring W2 = Wireless Pressure Monitoring Only W3 = Wireless Vacuum Monitoring Only W4 = Wired Pressure and Vacuum Monitoring W5 = Wired Pressure Monitoring Only W6 = Wired Vacuum Monitoring Only

## MODEL ES-850 PRESSURE/VACUUM RELIEF VALVE MODEL NUMBER

Model	Inlet Size	Housing Material	Pallet and Seat Material	Pallet Seal Material	Body/Seat/Lid Seal Material
ES-950	2 to 12 in.	1 = Aluminum 4 = 316SST 5 = Carbon Steel	2 = 316SST	1 = FEP 2 = Nitrile (NBR) 3 = Fluorocarbon (FKM) 4 = Fluorosilicone (FVMQ)	1 = PTFE Body and FEP Seat/Lid 2 = Nitrile (NBR) 3 = Fluorocarbon (FKM) 4 = Fluorosilicone (FVMQ)

Pressure Units	Pressure Setting	Vacuum Units	Vacuum Setting	Weight Material	Options
z = oz./sq. in. n = in. w.c. mm = mm w.c. mb = mbar	0.5 to 32.0 oz./sq. in. 0.86 to 55.0 in. w.c. 22 to 1406 mm w.c. 2.2 to 138 mbar	z = oz./sq. in. n = in. w.c. mm = mm w.c. mb = mbar	0.5 to 32.0 oz./sq. in. 0.86 to 55.0 in. w.c. 22 to 1406 mm w.c. 2.2 to 138 mbar	C = CS ZP S = SST L = Lead	0 = No Options F = Flat Face Flange (standard for Aluminum) R = Raised Face Flange (standard for CS, SS) X = Epoxy Coating W1 = Wireless Pressure and Vacuum Monitoring W2 = Wireless Pressure Monitoring Only W3 = Wireless Vacuum Monitoring Only W4 = Wired Pressure and Vacuum Monitoring W5 = Wired Pressure Monitoring Only W6 = Wired Vacuum Monitoring Only

## MODEL ES-950 PRESSURE/VACUUM RELIEF VALVE MODEL NUMBER

Figure 3. Pressure/Vacuum Relief Valve Model Number

North America Only

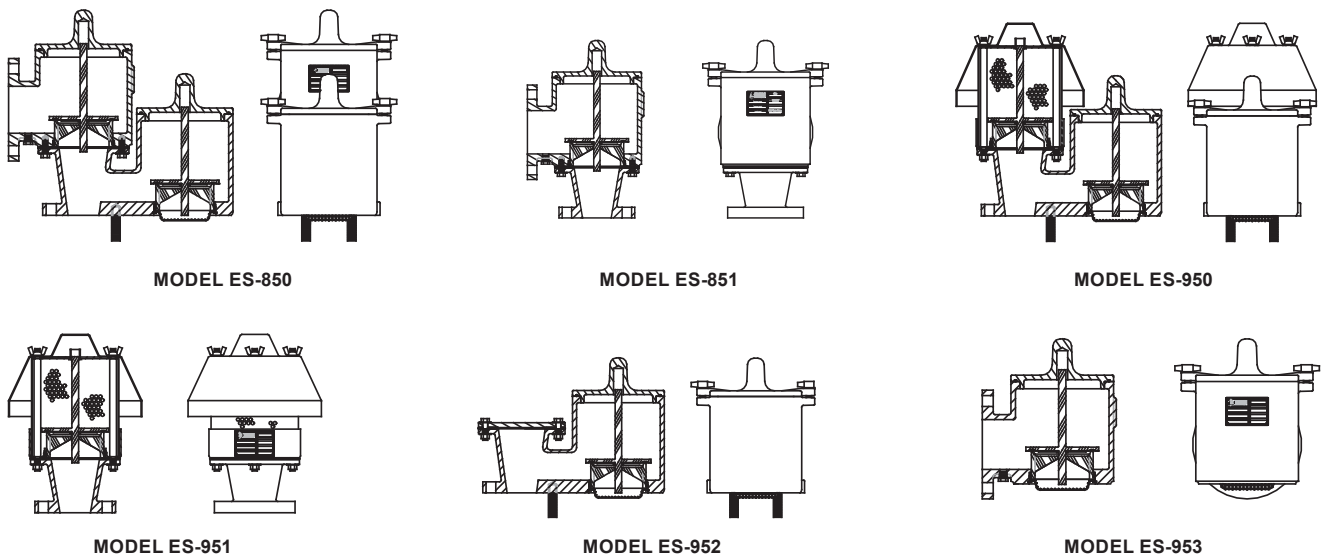

Figure 4. ES-850 and ES-950 Series Pressure/Vacuum Relief Valve Available Models

# ES-850 and ES-950 Series

**Table 1. Model ES-850 Weights<sup>(1)</sup>**

INLET CONNECTION		OUTLET CONNECTION		WEIGHT (ALUMINUM)		WEIGHT (STAINLESS STEEL OR CARBON STEEL)		WEIGHT OF CALIBRATION WEIGHTS REQUIRED TO ACHIEVE DESIRED RELIEF SETTING <sup>(2)(3)</sup>			
In.	mm	In.	mm	Lb	kg	Lb	kg	Weight per oz/sq. in.		Weight per in. w. c.	
								Lb	kg	Lb	kg
2	50	3	80	29	13	80	36	0.9	0.3	0.5	0.2
3	80	3	80	31	14	85	39	0.9	0.3	0.5	0.2
3	80	4	100	33	15	90	41	0.9	0.3	0.5	0.2
4	100	6	150	57	26	144	65	2.3	1.0	1.3	0.6
6	150	6	150	62	28	155	70	2.3	1.0	1.3	0.6
6	150	8	200	70	32	178	81	2.3	1.0	1.3	0.6
8	200	10	250	161	73	485	220	7.8	3.5	4.5	2.0
10	250	10	250	166	75	503	228	7.8	3.5	4.5	2.0
10	250	12	300	172	78	525	238	7.8	3.5	4.5	2.0
12	300	12	300	175	79	532	241	7.8	3.5	4.5	2.0
12	300	14	350	208	94	622	282	7.8	3.5	4.5	2.0

1. Unit weights indicate Net Weight of valve in pounds and kilograms at standard set pressure (0.5 oz/sq. in. pressure – 0.5 oz/sq. in. vacuum). It does not include shipping crate or box.
2. Multiply the relief setting by the value shown to determine the weight of the calibration weights used to achieve the desired relief setting.
3. Values shown for calibration weights are for reference purposes only. They are not intended to be used for determination of valve relief setting.

**Table 2. Model ES-950 Weights<sup>(1)</sup>**

INLET CONNECTION		WEIGHT (ALUMINUM)		WEIGHT (STAINLESS STEEL OR CARBON STEEL)		WEIGHT OF CALIBRATION WEIGHTS REQUIRED TO ACHIEVE DESIRED RELIEF SETTING <sup>(2)(3)</sup>			
In.	mm	Lb	kg	Lb	kg	Weight per oz/sq. in.		Weight per in. w. c.	
						Lb	kg	Lb	kg
2	50	21	10	54	24	0.9	0.3	0.5	0.2
3	80	23	10	58	26	0.9	0.3	0.5	0.2
4	100	41	19	110	50	2.3	1.0	1.3	0.6
6	150	45	20	123	56	2.3	1.0	1.3	0.6
8	200	123	56	362	164	7.8	3.5	4.5	2.0
10	250	129	59	383	174	7.8	3.5	4.5	2.0
12	300	144	65	405	184	7.8	3.5	4.5	2.0

1. Unit weights indicate Net Weight of valve in pounds and kilograms at standard set pressure (0.5 oz/sq. in. pressure – 0.5 oz/sq. in. vacuum). It does not include shipping crate or box.
2. Multiply the relief setting by the value shown to determine the weight of the calibration weights used to achieve the desired relief setting.
3. Values shown for calibration weights are for reference purposes only. They are not intended to be used for determination of valve relief setting.

## Smart Wireless Monitoring Option



**WARNING**

**The surface resistivity of the antenna assembly when the optional transmitter is installed is greater than 1 GΩ. To avoid electrostatic charge build up, it must not be rubbed or cleaned with solvents or dry cloth.**

The Smart Wireless Monitoring Option is available with PVRV Models ES-850 (Pipe-away) and ES-950 (Vent-to-Atmosphere). This option allows the remote sensing and “OPEN/CLOSED” value transmission of the open or closed status of the pressure vent, the vacuum vent or both. Use Option Code WP for pressure vent monitoring, Option Code WV for vacuum vent monitoring or WPV for the monitoring of both at the end of the model string. Knowing whether a PVRV is open or closed can enable immediate response to prevent problems related to safety, emissions and quality of the tank contents.

The following are a few specific examples of how this added visibility can help prevent problems:

### Example #1 – Redundant PVRVs

Redundant PVRVs are commonly used for added safety. If the primary PVRV fails closed or partially-closed, then the backup PVRV automatically takes over. This is achieved by establishing a pressure set point that is slightly higher for the backup device. In this way, if the primary PVRV fails, the tank remains protected. But redundancy is lost and should be addressed as soon as possible. But how will you know if this has occurred? Monitoring the open/closed position of the backup PVRV can provide quick identification of this issue, for either the pressure or vacuum side. Under normal conditions, the backup PVRV remains closed. If the backup PVRV is open, this points to either the primary PVRV not functioning as expected or a separate pressure control problem in the tank system that is causing both PVRVs to be open. Ideally, the wireless monitoring of both primary and backup devices is preferred in order to gain the most insight. Further troubleshooting can then be performed and the problem can be detected and addressed.

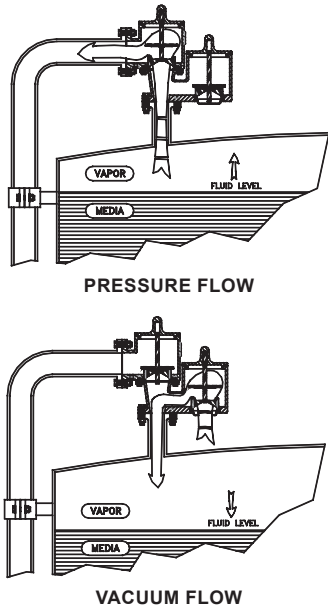

Figure 5. Pressure and Vacuum Flow

### Example #2 – Tank Blanketing

Tank blanketing is sometimes used in order to inert the vapor space in a tank for added safety. A tank blanketing regulator controls the inflow of nitrogen or another blanketing gas by responding to a low pressure set point. In this scenario, a PVRV (vacuum side) generally acts as a backup to the blanketing regulator. If the blanketing system fails for some reason, the PVRV automatically takes over, as its set point is slightly higher than that of the regulator. But once again, how is one to know that this has occurred? A wireless-monitored PVRV would indicate that the vacuum side is open. Under normal operation, it should be closed.

### Example #3 – Emergency Vent

A storage tank's emergency vent should remain closed, except in abnormal conditions. If an emergency vent is also remotely monitored, and found to be open, then there may be a pressure control issue somewhere in the system. In this scenario, the PVRV should also be open. If it is not, it could be part of the issue. Again, a wireless-monitored PVRV can readily provide this information.

## Product Identification and Marking



**As part of the legacy Model 850/950 ATEX certification, an ignition risk analysis was performed. Grounding of the unit is not deemed to be necessary because all conducting parts of the equipment are arranged such that a dangerous potential difference cannot exist between them. However, grounding or bonding allowances can be made at user request if internal, local or national codes or standards require.**



-  II 1 G Ex h IIC T6 Ga OUTER HOUSING OF STAINLESS STEEL, CARBON STEEL OR COATED ALUMINUM
-  II 2 G Ex h IIC T6 Gb OUTER HOUSING OF UNCOATED ALUMINUM

Figure 6. Product Identification and Marking

## Hazardous Locations

Enardo™ pressure/vacuum relief valves are available with outer housings of carbon steel, stainless steel or aluminum, as indicated in Figure 6.

## Nameplate

A nameplate is attached to the valve and contains the following information:

- **Model Number** – Ex. ES-950-8-5211
- **Size** – Ex. 8 in.
- **Serial Number**
- **Tag Number** (Optional)
- **Notified Body Number** – Ex. 2460
- **Cat. No. (Category Number)** –
  - Category 1 – Stainless steel, Carbon steel or Coated aluminum vent
  - Category 2 – Uncoated aluminum vents
- **Date** – Date of Manufacture
- **Certificate** – Ex. PRESAFE 17 ATEX 10273X
- **Pressure Setting and Flow Rate**
  - Setting – Ex. Z4.0
  - Flow Rate SCFH (Air) – Ex. 00000
- **Vacuum Setting and Flow Rate**
  - Setting – Ex. Z0.5
  - Flow Rate SCFH (Air) – Ex. 00000

## Principle of Operation

### ES-850 and ES-950 Series

The ES-850 and ES-950 Series pressure/vacuum relief valves maintain a tight seal until system pressure or vacuum exceeds the set pressure of the valve. Set pressure is determined by stacking a series of weights onto the valve pallet unless the pressure and vacuum set points have been specified for the minimum settings. When overpressure occurs, the weighted pallet lifts, breaking the seal between the seat and pallet. This allows vapors to pass through the valve orifice and relieve pressure buildup. The valve reseals upon relief and remains sealed.

It is important to know that relieving vapors near the set pressure in a continuous manner may cause the pallet to flutter or oscillate inside the valve chamber. This is common to products of this type. Operating the valve with flutter or oscillation may cause premature valve damage or wear over time. Enardo pressure/vacuum relief valve flow charts and sizing program results designate the “flutter zone” to assist with correct valve sizing. Contact your local Sales Office with any questions or additional assistance.

# ES-850 and ES-950 Series

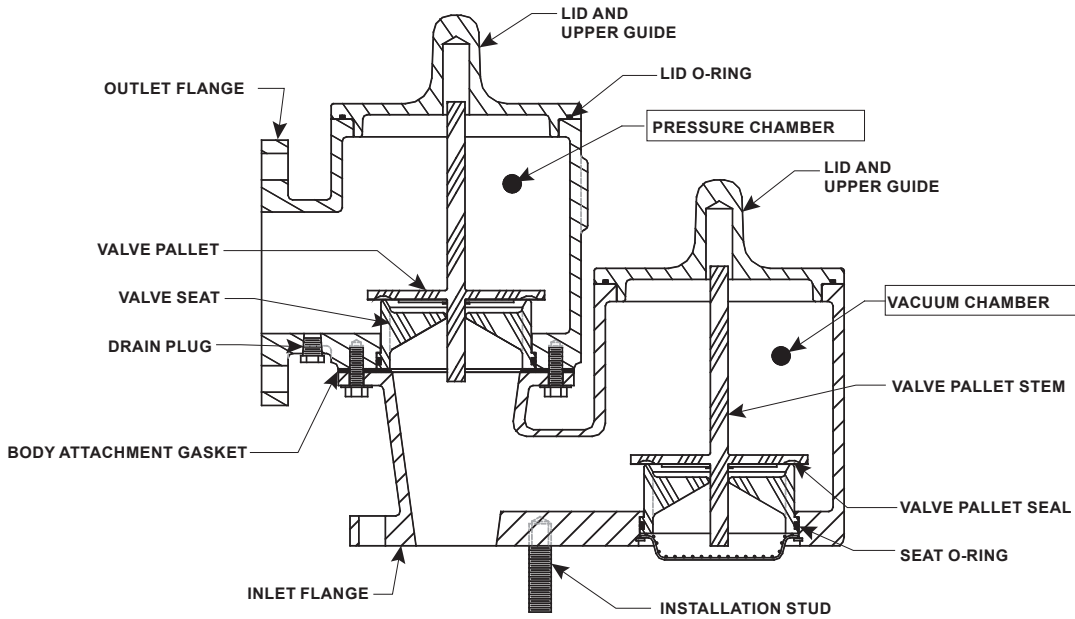

MODEL ES-850 PIPE-AWAY PRESSURE/VACUUM RELIEF VALVE

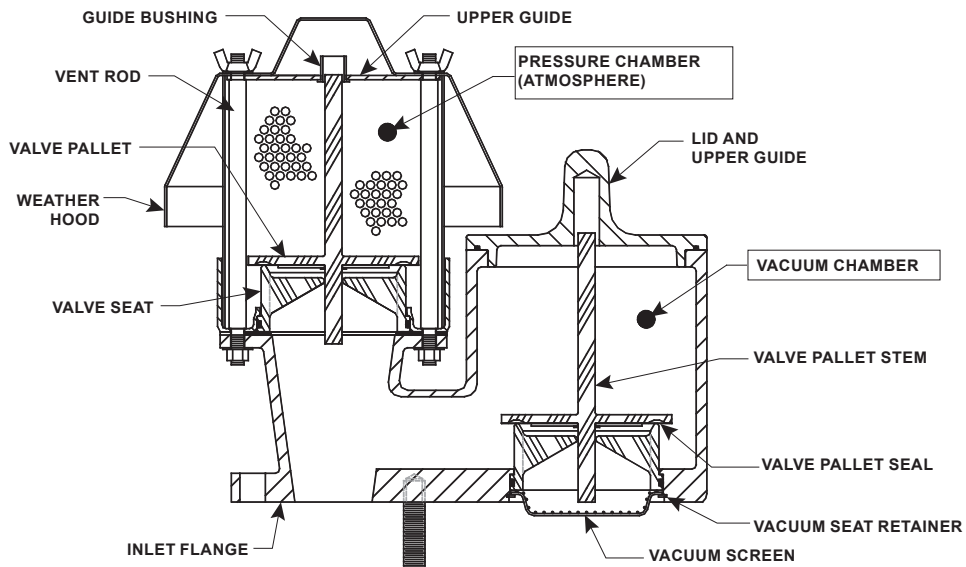

MODEL ES-950 VENT-TO-ATMOSPHERE PRESSURE/VACUUM RELIEF VALVE

Figure 7. Models ES-850 and ES-950 Pressure/Vacuum Relief Valve Assembly

North America Only

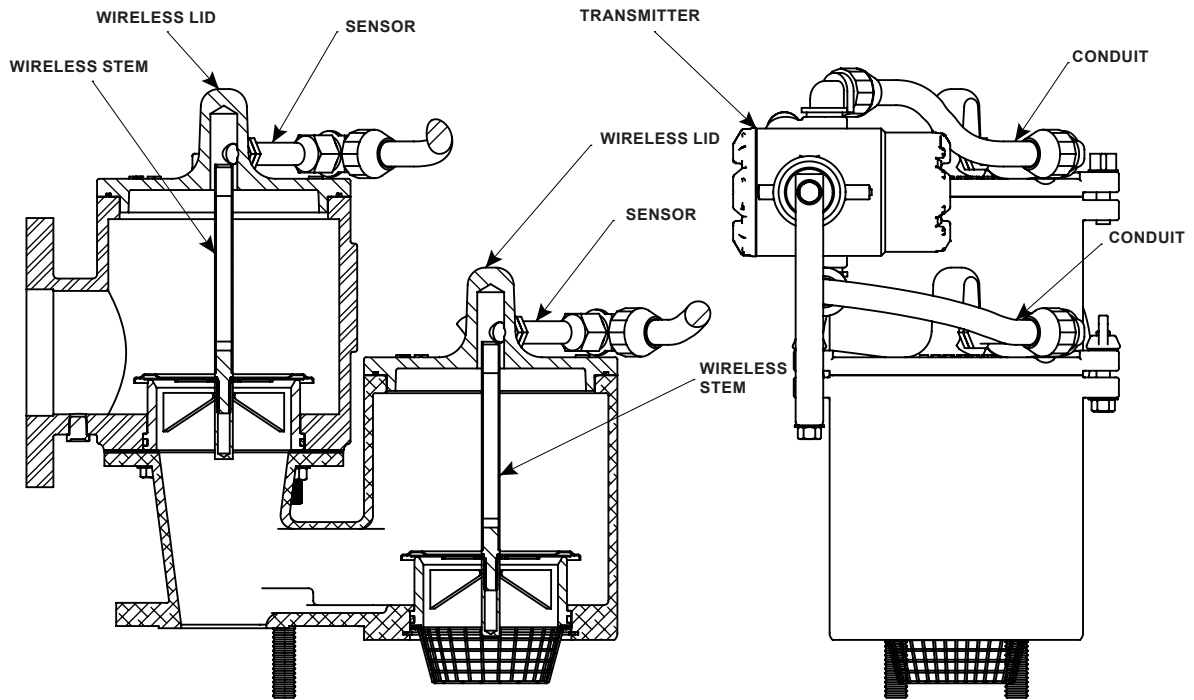

Figure 8. Model ES-850 with Smart Wireless Option

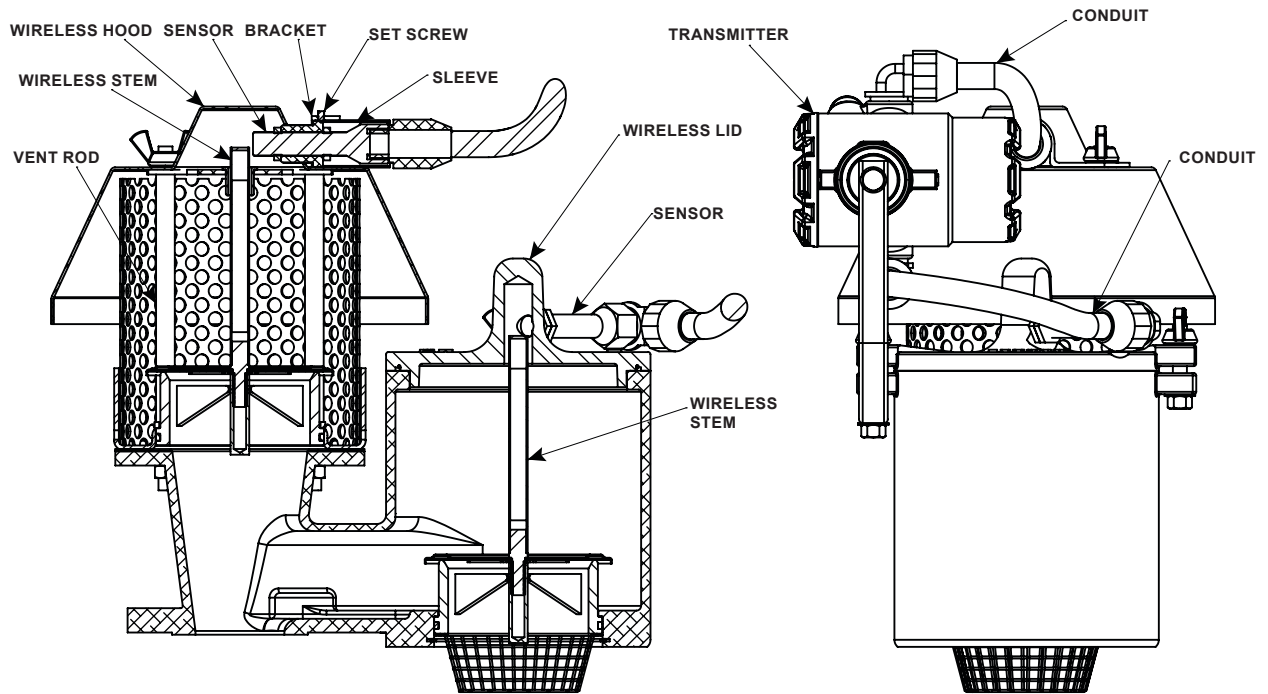

Figure 9. Model ES-950 with Smart Wireless Option

# ES-850 and ES-950 Series

## Installation

### ES-850 and ES-950 Series

#### WARNING

Take all necessary precautions and safety measures when lifting valves into place to prevent unbalanced load situations. Do not install calibration weights or pallet assemblies prior to mounting and installation of valve. Special care must be taken during installation to prevent damage to the seat sealing surface.

Wear protective gloves and clothing to prevent skin contact when handling lead weights. Wear eye protection. Avoid breathing dust/fumes/mist/vapors/spray. Do not eat, drink or smoke while using the product. Avoid release to the environment. Wash hands with soap and water after handling. Keep away from excessive heat and open flames.

If lead weights need to be disposed of, follow all local, regional and national regulatory requirements for the safe and proper disposal of lead.

Make sure line is free of hazardous vapors before installing or servicing the valve.

Product material of construction can include aluminum, carbon steel and stainless steel. Care should be taken to avoid mechanical impacts that could result in a spark.

1. Loosen fasteners on top of the valve and remove the lid, hood or guide.

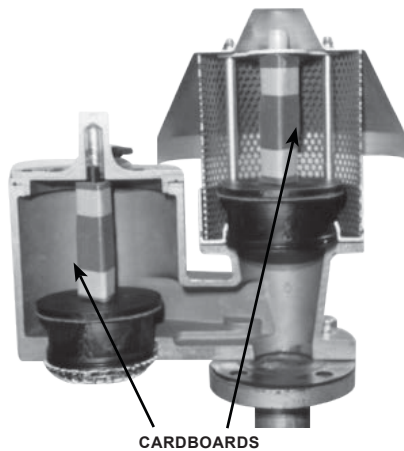

REMOVE CARDBOARD FROM PALLET STEMS



CARDBOARD  
REMOVE CARDBOARD FROM PALLET STEMS

#### Note

All product configurations use similar packing methods.

2. Remove valve pallets from the unit. Separate the protective cardboard coverings from the pallet stems and seals. Gently clean the seal with a suitable solvent and lint free, nonabrasive cloth to remove any dirt/particles and achieve good seal tightness. Be careful not to damage the pallet seal surface.



3. Reinsert uncovered valve pallets back into the unit. Make sure that the lower stem is being guided by the saber guides before lowering the pallet onto the seat to avoid hitting the seat sealing edge with an off-set pallet. If the pallet appears to be off-center to the valve chamber, or if there is difficulty positioning the lid or guide, carefully inspect the pallet to ensure it is inserted properly.
4. Remove any protective flange covers.



## Note

For more details on using weights to adjust the pallet setting, read the Adjustments section.

## CAUTION

Use care when installing weights and securing lids to avoid getting pinched.

5. Reinstall pressure and/or vacuum pallet assemblies into their respective openings. Install the setting weights (if required) by engaging the hole in the weight on the appropriate pallet assembly stem.
  - 5.1. The weights are marked with their pressure equivalents and are shipped outside of the valve chamber. Verify that the appropriate weights are being installed to provide the specified pressure and/or vacuum setting. Refer to the nameplate data to verify the specified factory settings.



- 5.2. To adjust valve settings higher than minimum, use the weights to increase the pressure setting. Weights are packed separately within the unit shipping package and are labelled "PRESSURE" and/or "VACUUM". If weights are shipped with the unit, they should be installed onto the pallets in the valve chamber in which they are labelled. Gently slide the weights onto the pallet stem and down on top of the valve pallet.

For 10 in. / 250 mm FEP pallets make sure to put the PTFE (Teflon®) spacer on top of the pallet before adding the weights.

## Note

Make sure that the pallet assembly stem positively engages the stem guide hole in the hood or cover. Each pallet assembly must be free to move upwards, with the pallet stem travelling into the stem guide.

Teflon® is a mark owned by E.I. du Pont de Nemours and Co.

## CAUTION

Use care when installing weights and securing lids to avoid getting pinched.

6. Install the covers and/or hood.
7. Re-use existing wing nuts or nuts and tighten to secure covers/hoods in position.
8. Attach the valve to the appropriate mating flange using appropriate flange gasket which is compatible with process conditions (customer provided). To ensure proper function, install the valve to a level surface, not greater than 1° off horizontal so the pallet will move vertically. Valves that are tilted during usage may suffer premature damage or wear, and may have more leakage.

For proper bolt torquing of the valve connecting flange to the piping, please refer to Tables 3 to 5.

## Smart Wireless Monitoring

## WARNING

Do not thread wireless sensor too far into lid. Sensor may contact pallet stem and prevent valve from opening properly. This condition may result in equipment damage or personal injury.

Units with Smart Wireless are shipped as self-contained and already connected. The only connection required is installation of the transmitter battery (shipped separately) which is intrinsically safe and does not require a hot-work permit.

1. Install valves with the Smart Wireless monitoring option in a similar manner to the standard PVRVs with a few differences. Remove any cardboard or other packaging from the inner chambers. Remove the lid(s) and/or hood to allow insertion of the appropriate weights during installation.
2. Remove any lid with the sensing equipment threaded into it as a single unit. The sensor should remain engaged with the lid during this process. Position all sensors within 0.100 in. of the pallet stem. Maintain this critical distance. If the sensor location within a lid is altered, re-test the unit to ensure proper functioning of the sensor and transmitter. If this is the case, re-apply thread sealant to mitigate any leakage of the sensor/lid interface.

# ES-850 and ES-950 Series

**Table 3. Torque Specifications - Raised Face Flange, Steel Only**

NOMINAL PIPE DIAMETER	NUMBER OF BOLTS	BOLT DIAMETER, IN.	TORQUE, FT-LBS
2	4	0.63	35
3	4	0.63	60
4	8	0.63	43
6	8	0.75	80
8	8	0.75	109
10	12	0.88	101
12	12	0.88	135
14	12	1.00	168

Assumptions: Use of SAE grade 5 bolts or studs or stronger. No lubricant. Compressed mineral fiber material or similar.  
 Notes: If lubricant is used on bolts, apply torque reduction factor listed in Table 5. For best results, hardened steel washers should be used on all cast flange bolted connections.

**Table 4. Torque Specifications - Flat Face Flange, Steel or Aluminum**

NOMINAL PIPE DIAMETER	NUMBER OF BOLTS	BOLT DIAMETER, IN.	TORQUE, FT-LBS
2	4	0.63	32
3	4	0.63	47
4	8	0.63	32
6	8	0.75	49
8	8	0.75	68
10	12	0.88	69
12	12	0.88	98
14	12	1.00	138

Assumptions: Use of SAE grade 5 bolts or studs or stronger. No lubricant. Elastomer <70 Durometer Shore A.  
 Notes: Flat faced flanges should never be mated to a raised face flange for installation. If lubricant is used on bolts, apply torque reduction factor listed in Table 5. For best results, hardened steel washers should be used on all cast flange bolted connections.

**Table 5. Torque Reduction Factors per Lubricant**

DESCRIPTION	COEFFICIENT OF FRICTION	MULTIPLY TORQUE VALUE IN TABLE BY
Machine Oil	f = 0.15	0.75
API SA2 Grease	f = 0.12	0.60
Nickel-based Lubricant	f = 0.11	0.55
Copper-based Lubricant	f = 0.10	0.50
Heavy-Duty Lubricating Paste	f = 0.06	0.30



Figure 10. Model ES-850, Installation of Weights



Figure 11. Model ES-950, Installation of Weights

- For the Model ES-950 PVRVs containing hoods, the sensor is located at a proper distance away from the stem by using a sleeve, bracket and set screw. The sensor is held within the sleeve using two jam nuts. Fasten the sleeve to the hood using a bracket. Using a set screw, mate the bracket and sleeve to ensure that the sensor is in the proper location and cannot be adjusted. When installing weights, lift the hood and sensor/bracket/sleeve off the vent rods as one. Remove the sensor/bracket/sleeve from the hood and install the weights. Reverse the process to reassemble the hood and sensor.

**Wash hands with soap and water after handling. Keep away from excessive heat and open flames. Ensure that all proper safety procedures and safeguards are followed when working on units, especially if they are in the elevated position.**

**Make sure line is free of hazardous vapors before installing or servicing the valve.**

**Observe all applicable safety requirements. Only qualified and trained personnel shall perform maintenance functions in hazardous locations.**

**Valves should be removed from the location having a potentially explosive atmosphere and taken to a safe location for repair and maintenance.**

## Maintenance

### ES-850 and ES-950 Series

#### **WARNING**

**Wear protective gloves and clothing to prevent skin contact when handling lead weights. Wear eye protection. Avoid breathing dust/fumes/mist/vapors/spray. Do not eat, drink or smoke while using the product. Avoid release to the environment.**

#### **CAUTION**

**When removing and installing seats, ensure to handle it with care to prevent damage (scratches, nicks, etc.) to the sealing surface.**

# ES-850 and ES-950 Series

For preventive maintenance of the Enardo™ pressure/vacuum relief valve, refer to the following instructions.



1. Loosen the fasteners on top of the valve and remove the lid, hood or guide.



2. Remove any valve pallets and weights from the unit. Keep in mind that these will be reinstalled, so keep track of the chamber from which they were removed.



3. Inspect the pallets for any damage or buildup that may affect its sealing characteristics or its ability to move properly inside the valve. Gently clean the seal with a suitable solvent and lint free, nonabrasive cloth to remove any dirt/particles and achieve good seal tightness.



4. Clear away any buildup on the weights or on the housing.

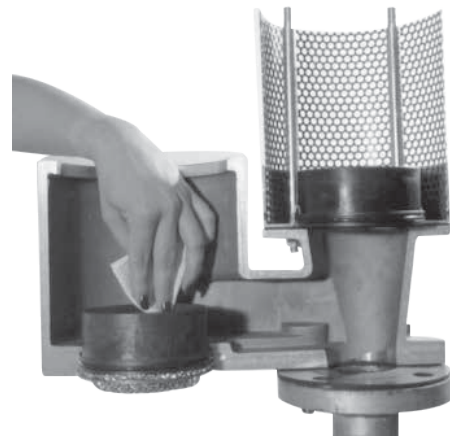

5. Inspect the valve seats installed in the unit. The sealing surfaces should be smooth and free of nicks or buildup. A good, clean seat sealing surface free from defects is essential to achieving a tight seal. Check the guides for anything that may keep the valve pallet from moving properly inside the valve. If necessary, gently clean the seats with a suitable solvent and nonabrasive cloth.



6. If the valve has a lid, clean any buildup that may exist in or around the guide hole located in the center of the part.



7. If the valve is fitted with a screen of some type, clear away any blockage that may impede proper flow.



8. Reinstall valve pallets and weights into their proper chambers. Make sure the lower stem on the pallet is centered into the valve seat. If the pallet appears to be off-center to the valve chamber, or if there is difficulty positioning the lid or guide, the pallet may be inserted improperly.



9. Reinstall weights onto their appropriate valve pallets.

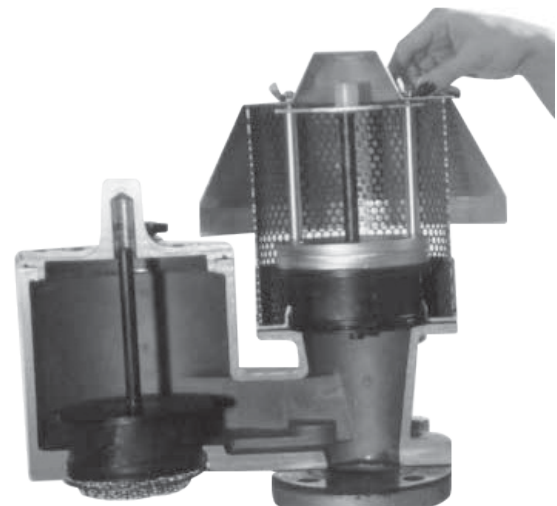

10. Replace any lid, hood or guide that was previously removed and fasten securely. When tightening down lids, make sure the O-ring in each lid has full contact with the sealing surface.
11. For seat removal, see Figure 7 for the valve configuration drawings. The valve seats are installed in machined bores in both the upper body (pressure) and in the lower body (vacuum) and are fitted with O-ring seals. Remove the upper body seat by removing the upper body casting (Model ES-850) or the Vent Hood assembly (Model ES-950). Then remove the seat from the bore. The lower seat (vacuum) is retained by a Spirolox® retaining ring. Remove this ring with a flat-bladed screwdriver as shown above.

# ES-850 and ES-950 Series

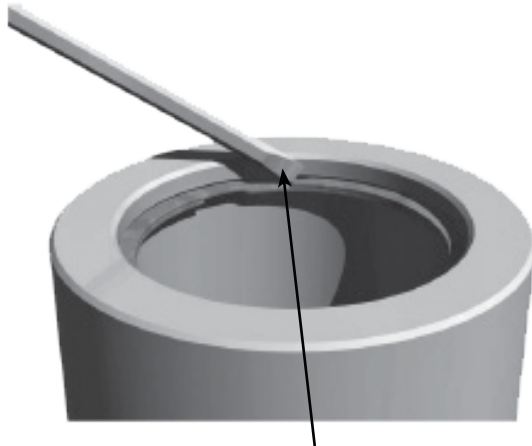

Remove ring using a flat-bladed screwdriver

12. For seat replacement, the seats are installed in the reverse order of the removal. Make sure the bores are clean and that the O-ring seals are not damaged. Use a light lubricant when replacing the O-ring and seat.

## Retrofit Kits

The stainless steel seats, pallet assemblies and gaskets used in the ES Series valves are completely backwards compatible with Models 850/950 valves already installed; even those with PPS pallets and seats. Existing valves can be upgraded via readily available retrofit kits. Each kit contains one (1) ES Series valve seat, one (1) seat O-ring, one (1) lid O-ring, one (1) body gasket and one (1) pallet seal. For 8, 10 and 12 in. valves that require FEP pallet seals, the retrofit kit contains a complete pallet assembly. For valves that have both pressure and vacuum relief capabilities, two (2) retrofit kits are required to upgrade the entire valve. Note that the kits are not specific to the venting function and can be used on either the pressure or vacuum side of the valve.

Follow the instructions outlined in the Maintenance section of this manual to replace the existing seats, gaskets and when required, pallet assemblies. Once the upgrade is complete, place the green retrofit sticker that is included with each kit next to the nameplate of the valve as shown in Figure 12. The sticker provides confirmation that the valve has been upgraded to the ES Series configuration.

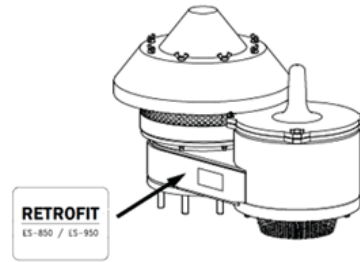



PLACE RETROFIT STICKER NEXT TO VALVE NAMEPLATE.

Figure 12. Model 950 PVRV Retrofit Sticker Placement

## Smart Wireless Monitoring Maintenance

1. Maintain Wireless Models ES-850 and ES-950 PVRVs in the same way as all standard Models ES-850 and ES-950 PVRVs. Clean the pallet and seat sealing surfaces, remove any buildup of residues on the weights and ensure any screens are not blocked.
2. Take certain precautions when cleaning the transmitter. The surface resistivity of the antenna assembly when the optional transmitter is installed is greater than 1 GΩ. To avoid electrostatic charge build-up, it must not be rubbed or cleaned with solvents or dry cloth.

The overall ATEX rating for all Wireless Models 850 and 950 Valves are listed below:

Zone 0:  II 1 G Ex h ia IIC T5 Ga  
Zone 1:  II 2 G Ex h ia IIC T5 Gb

## Adjustments

The Enardo™ pressure/vacuum relief valves have wide range of pressure and vacuum settings in units of ounces per square inch (oz./sq. in.) or inches of water column (in. w.c.) as indicated in the specification section of this instruction manual. Standard Enardo valve pallets assemblies are marked with a minimum equivalent pressure value in the specified units. Installed alone has minimum settings of 1/2 oz./sq. in. or 1 in. w.c. The pallets are calibrated by the seal support located on the bottom side of the pallet. The pallet's setting of 1/2 oz./sq. in. or 1 in. w.c. is etched into the support. When a valve requires a setting higher than the 1/2 oz./sq. in. or 1 in. w.c. standard pallet setting, use weights to increase the pallet's setting up to the required setting. The same seal support used with FEP seals on 8 in. / 200 mm and larger valves. In this case, the base calibration of the pallet assembly can be determined by examining the upper and lower guide stems. Pallet assemblies calibrated to 1.0 in. w.c. or 25 mm w.c. will have stems fabricated using solid bar stock. Pallet assemblies calibrated to 0.5 oz./sq. in. or 2.2 mbar will have stems that have been fabricated using tubing with plugged ends.



**Figure 13. Weights on Pallet**

**Table 6. Valve Maintenance**

PART	REPLACEMENT
Pallet Seals	Simple replacement. Provided with gasket repair kit along with other gaskets. The pallet seals are fragile and should be handled carefully to avoid damage. They must never be folded or creased. Never use abrasive cleaners on a pallet seal.
Pallet Assemblies	Drop-in replacement. Requires removal of lid. Replace pallet seal as needed. For best results replace entire pallet assembly. Again, care must be taken not to damage the seals.
Body Gaskets	Requires disassembly. Provided with gasket repair kit
Seats	Requires O-ring gasket to be replaced as well. Use care when removing and installing seats to prevent damage (scratches, nicks, etc.) to the sealing surface. Use a light lubricant when replacing the O-ring and installing the seat.

Additional calibration weights are marked with their equivalent pressure value and should be added as necessary to achieve the specified setting.

Enardo™ weights also come in units of ounces per square inch (oz./sq. in.) or inches of water column (in. w.c.). The individual setting of each weight is either etched or imprinted into the weight. Emerson offers several different sizes of pressure/vacuum relief valves. To ensure that the right weight is placed on the right pallet, take note that the weights and pallets that go together will have the same outside diameter. Standard Enardo weights allow the user to stack in increments of 1/2 oz./sq. in. or 1/2 in. w.c.

Pressure/vacuum relief valve is shipped with prepackaged weight kits to set the valve pressure properly. The package labelled “pressure” is for the pallet in the pressure chamber, while the package labelled “vacuum” is for the pallet in the vacuum chamber. All weights in these packages should be installed. If one or neither of these packages is included with

your order, then they are not needed. For 8 in. / 200 mm and larger valves that use FEP seals, a PTFE spacer is included and must be installed on top of the pallet before any calibration weights are added. The spacer is not used if no additional calibration weights are needed.

If the pressure and vacuum weights are mixed together, sort and reorganize the weights.

When installing weights for the Enardo pressure/vacuum relief valve, check the required settings on the tag attached to the valve. Add weights to the pallet to achieve the required setting. If the relief valve’s setting is 6 oz./sq. in., add weights with the total setting of 5-1/2 oz./sq. in. to the valve since the pallet’s setting alone is 1/2 oz./sq. in. Hence, the valve pressure setting is the sum of the settings of the pallet and the weights. The relief pressure or vacuum setting is equal to the sum of the pallet assembly and individual calibration weight equivalent pressure value.

# ES-850 and ES-950 Series

## Valve Repair



### WARNING

**Make sure line is free of hazardous vapors before installing or servicing the valve.**

**Observe all applicable safety requirements. Only qualified and trained personnel shall perform maintenance functions in hazardous locations.**

**All replacement parts must be provided by Emerson.**

Remove the valve from the tank before attempting any repairs beyond pallet assembly and weight maintenance as described on Maintenance section.

Most repairs will consist of replacing pallet seals, lid gaskets and in some cases, the body gaskets. The seats are also replaceable if the need arises. These repairs are relatively simple and can normally be handled by plant maintenance personnel using common hand tools.

Most valve maintenance can be performed by the customer or by a valve repair facility. See Table 6 for the proper maintenance of the relief valve parts.

In most cases, it is not necessary to return the valves to the factory. If the valve needs to be tested and certified at a specified pressure and/or vacuum, return it to the factory or send it to a qualified valve repair facility that is capable of performing the necessary tests in accordance with API Bulletin 2521 recommendations.

Contact your local Sales Office with any questions or additional assistance needed for repairing your valve.

 [Webadmin.Regulators@emerson.com](mailto:Webadmin.Regulators@emerson.com)

 [Enardo.com](http://Enardo.com)

 [Facebook.com/EmersonAutomationSolutions](https://www.facebook.com/EmersonAutomationSolutions)

 [LinkedIn.com/company/emerson-automation-solutions](https://www.linkedin.com/company/emerson-automation-solutions)

 [Twitter.com/emr\\_automation](https://twitter.com/emr_automation)

### Emerson Automation Solutions

#### Americas

McKinney, Texas 75070 USA  
T +1 800 558 5853  
+1 972 548 3574

Tulsa, OK 74146 USA  
T +1 918 662 6161

#### Europe

Bologna 40013, Italy  
T +39 051 419 0611

#### Asia Pacific

Singapore 128461, Singapore  
T +65 6777 8211

#### Middle East and Africa

Dubai, United Arab Emirates  
T +971 4 811 8100

D104631X012 © 2021 Emerson Process Management Regulator Technologies, Inc. All rights reserved. 12/21.

The Emerson logo is a trademark and service mark of Emerson Electric Co. All other marks are the property of their prospective owners. Enardo™ is a mark owned by Regulator Technologies Tulsa, LLC, a business of Emerson Automation Solutions.

The contents of this publication are presented for informational purposes only, and while every effort has been made to ensure their accuracy, they are not to be construed as warranties or guarantees, express or implied, regarding the products or services described herein or their use or applicability. We reserve the right to modify or improve the designs or specifications of such products at any time without notice.

Emerson Process Management Regulator Technologies Tulsa, LLC does not assume responsibility for the selection, use or maintenance of any product. Responsibility for proper selection, use and maintenance of any Emerson Process Management Regulator Technologies Tulsa, LLC product remains solely with the purchaser.