

September 2016

67CFS Series Installation Sheet

Introduction

This installation sheet covers the installation and startup of the 67CFS Series filter regulators. If maintenance is required, refer to the 67C Series Instruction Manual, D102601X012. Contact your local Sales Office to receive a copy of the instruction manual.

Specifications

Maximum Inlet Pressure

250 psig / 17.2 bar

Maximum Outlet Pressure

50 psi / 3.4 bar over outlet pressure setting

Outlet Pressure Ranges

0 to 35 psig / 0 to 2.4 bar

0 to 60 psig / 0 to 4.1 bar

0 to 125 psig / 0 to 8.6 bar

0 to 150 psig / 0 to 10.3 bar

Temperature Capabilities with Nitrile (NBR)

-40 to 180°F / -40 to 82°C

The internal relief valve is designed for minor seat leakage only. If maximum inlet pressure to the Type 67CFSR exceeds the maximum pressure ratings of the downstream equipment or exceeds the maximum allowable outlet pressure of the Type 67CFSR, additional overpressure protection is required.

1. Regulator operation within ratings does not preclude the possibility of physical damage from external sources or debris in the lines. Regulators should be inspected for damage periodically and after an overpressure condition.
2. Only personnel qualified through training and experience should install, operate and maintain a regulator. Make sure there is no damage to or foreign material in the regulator and all tubing/piping is free of debris.
3. Install the regulator so that flow is from the IN to the OUT connection as marked on the regulator body.
4. For best drainage, orient the drain valve (key 2) to the lowest possible point on the dripwell (key 5). This orientation may be improved by rotating the dripwell with respect to the body (key 1).

Installation



WARNING

Personal injury, property damage, equipment damage or leakage due to escaping gas or bursting of pressure containing parts may result if this regulator is overpressured or is installed where service conditions could exceed the limits given in the specifications or where conditions exceed any ratings of the adjacent piping or piping connections. To avoid such injury or damage, provide pressure relieving or pressure limiting devices (as required by the appropriate code, regulation or standard) to prevent service conditions from exceeding those limits.

The internal relief valve in the Type 67CFSR regulator does not provide full overpressure protection.



WARNING

A regulator may vent some gas to the atmosphere. In hazardous or flammable gas service, vented gas may accumulate and cause personal injury, death or property damage due to fire or explosion. Vent a regulator in hazardous gas service to a remote, safe location away from air intakes or any hazardous area. The vent line or stack opening must be protected against condensation or clogging.

67CFS Series

5. A clogged spring case vent hole may cause the regulator to function improperly. To keep this vent hole from being plugged (and to keep the spring case from collecting moisture, corrosive chemicals or other foreign material) orient the vent to the lowest possible point on the spring case or otherwise protect it. Inspect the vent hole regularly to make sure it is not plugged. Spring case vent hole orientation may be changed by rotating the spring case with respect to the body. The 1/4 NPT spring case vent may be remotely vented by installing tubing or piping into the vent.
6. For regulator shutdown, install upstream block and vent valves and downstream block and vent valves (if required) or provide some other suitable means of properly venting the regulator inlet and outlet pressures.
7. Apply a good grade of pipe compound to the male pipe threads before making connections, making sure not to get the pipe compound inside the regulator.
8. Install tubing fitting or piping into the 1/4 NPT inlet connection on the body (key 1) and into the 1/4 NPT body outlet connection.
9. The second 1/4 NPT outlet can be used for a gauge or other use. If not used, it must be plugged.
10. When installing a 67CFS Series regulator in an existing installation, it may be necessary to use spacers to adapt the installation. If the mounting bolts are too long, place a spacer on the bolt. To be sure the regulator is secure, the bolts should have at least two full threads of engagement.

Startup and Adjustment

1. With proper installation completed and downstream equipment properly adjusted, slowly open the upstream and downstream shutoff valve (when used) while using pressure gauges to monitor pressure.



WARNING

To avoid personal injury, property damage or equipment damage caused by bursting of pressure containing parts or explosion of accumulated gas, never adjust the control spring to produce an outlet

pressure higher than the upper limit of the outlet pressure range for that particular spring. If the desired outlet pressure is not within the range of the control spring, install a spring of the proper range.

2. If outlet pressure adjustment is necessary, monitor outlet pressure with a gauge during the adjustment procedure. The regulator is adjusted by loosening the locknut (key 19), if used and turning the adjusting screw or handwheel (key 18) clockwise to increase or counterclockwise to decrease the outlet pressure setting. Tighten the locknut to maintain the adjustment position.

Parts List

Key	Description
1	Body
2	Drain Valve
3	Flange Screw
4	O-ring ⁽¹⁾
5	Dripwell
6	Filter Element ⁽¹⁾
7	Spring Case
9	Filter Retainer
10	Valve Cartridge ⁽¹⁾⁽²⁾
11	Valve Plug ⁽¹⁾⁽²⁾
12	Valve Spring ⁽¹⁾⁽²⁾
13	Valve Retainer ⁽¹⁾⁽²⁾
14	O-ring ⁽¹⁾⁽²⁾
15	Relief Valve Soft Seat ⁽¹⁾⁽²⁾
16	Diaphragm Assembly ⁽¹⁾
17	Spring
18	Adjusting Screw
19	Locknut
20	Upper Spring Seat
23	1/4 in. Pipe Plug (not shown)
25	Label
26	Filter Gasket ⁽¹⁾
33	Closing Cap
34	Spacer
37	Thrust Washer
45	Vent Screen

1. Recommended spare part

2. Valve cartridge assembly includes keys 10, 11, 12, 13, 14 and 15.

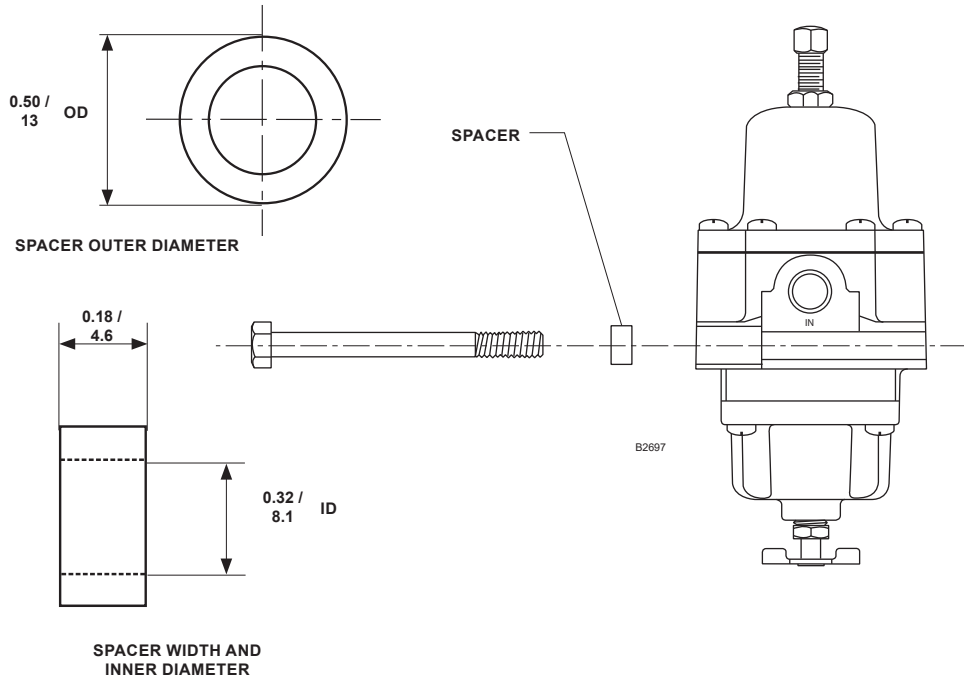

Figure 1. Spacer Diameter and Installation

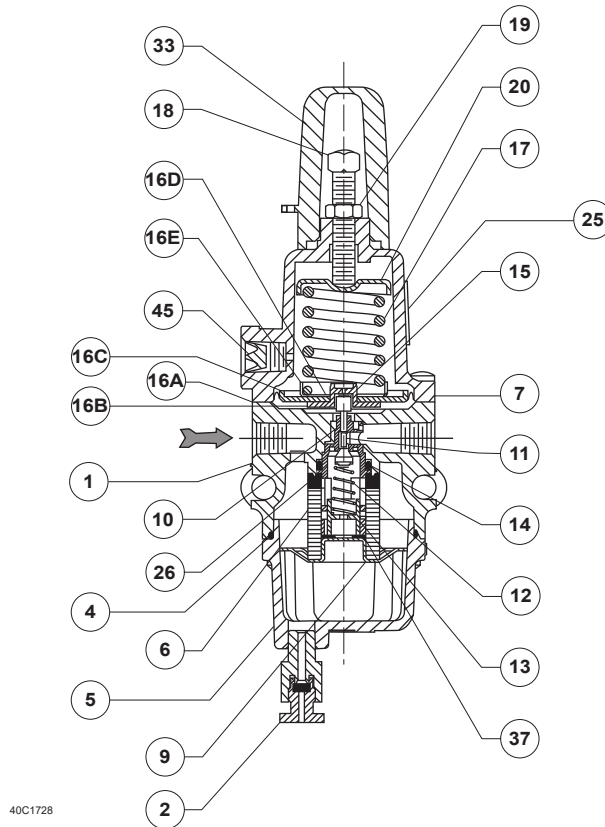

Figure 2. 67CFS Series Assembly

67CFS Series

✉ Webadmin.Regulators@emerson.com

🔍 Fisher.com

📘 Facebook.com/EmersonAutomationSolutions

🌐 LinkedIn.com/company/emerson-automation-solutions

🐦 Twitter.com/emr_automation

Emerson Automation Solutions

Americas

McKinney, Texas 75070 USA
T +1 800 558 5853
+1 972 548 3574

Europe

Bologna 40013, Italy
T +39 051 419 0611

Asia Pacific

Singapore 128461, Singapore
T +65 6777 8211

Middle East and Africa

Dubai, United Arab Emirates
T +971 4 811 8100

D103076X012 © 2003, 2024 Emerson Process Management Regulator Technologies, Inc. All rights reserved. 04/24.

The Emerson logo is a trademark and service mark of Emerson Electric Co. All other marks are the property of their prospective owners. Fisher™ is a mark owned by Fisher Controls International LLC, a business of Emerson Automation Solutions.

The contents of this publication are presented for informational purposes only, and while every effort has been made to ensure their accuracy, they are not to be construed as warranties or guarantees, express or implied, regarding the products or services described herein or their use or applicability. All sales are governed by our terms and conditions, which are available upon request. We reserve the right to modify or improve the designs or specifications of such products at any time without notice.

Emerson Process Management Regulator Technologies, Inc. does not assume responsibility for the selection, use or maintenance of any product. Responsibility for proper selection, use and maintenance of any Emerson Process Management Regulator Technologies, Inc. product remains solely with the purchaser.

