

Introduction

This Installation Guide provides instructions for installation and startup. To receive a copy of the Instruction Manual, contact your local Sales Office or view a copy at www.fisherregulators.com. For further information refer to: Type 63EGLP Instruction Manual, D450319T012.

P.E.D. Category

This product may be used as a safety accessory with pressure equipment in the following Pressure Equipment Directive 97/23/EC categories.

PRODUCT SIZE		CATEGORY	FLUID TYPE
DN	NPS		
100 ⁽¹⁾	4 ⁽¹⁾	IV	1

Specifications

Available Constructions

Type 63EGLP with two Type 6358EBLP Pilots
Type 63EGLP with two Type 6358EBHLP Pilots

Main Valve Body and End Connection Style⁽²⁾⁽³⁾

Steel: *CL300 RF Flange*: DN 100 / NPS 4

Maximum Relief (Inlet) Pressure⁽²⁾⁽³⁾

Type 63EGLP: 27.6 bar / 400 psig

Proof Test Pressure

All Pressure Retaining Components have been proof tested per Directive 97/23/EC - Annex 1, Section 7.4

Relief Set Pressure⁽²⁾

See Table 1

Maximum Temperature Capabilities⁽²⁾⁽⁴⁾

Nitrile (NBR): -29 to 82°C / -20 to 180°F

Installation



WARNING

Only qualified personnel shall install or service a relief valve. Relief valve should be installed, operated and

maintained in accordance with international and applicable codes and regulations and Emerson Process Management Regulator Technologies, Inc. instructions. Vapor relief valves must be installed only in the vapor space to provide relief capacity for the tank.

If using a relief valve on a hazardous or flammable fluid service, personal injury and property damage could occur due to fire or explosion of vented fluid that may have accumulated. To prevent such injury or damage, provide piping or tubing to vent the fluid to a safe, well-ventilated area or containment vessel. Also, when venting a hazardous fluid, the piping or tubing should be located far enough away from any buildings or windows so to not create a further hazard and the vent opening should be protected against anything that could clog it.

Personal injury, equipment damage or leakage due to escaping fluid or bursting of pressure-containing parts may result if this relief valve is overpressured or is installed where service conditions could exceed the limits given in the Specifications section or where conditions exceed any ratings of the adjacent piping or piping connections. To avoid such injury or damage, install a Type 63EGLP relief valve where service conditions are within unit capabilities (including those given in the Specifications section) and service conditions are within applicable codes, regulations or standards.

Additionally, physical damage to the relief valve could result in personal injury and property damage due to escaping fluid. To avoid such injury and damage, install the relief valve in a safe location.

1. See Instruction Manual to order a 4x3 in. flange reducer.
2. The pressure/temperature limits in this Installation Guide and any applicable standard or code limitation should not be exceeded.
3. Includes build-up.
4. Product has passed Fisher® performance testing for Start-to-Discharge and reseal at -40°C / -40°F.



Type 63EGLP

Table 1. Relief Set Pressure Ranges

TYPE	PILOT TYPE	RELIEF SET PRESSURE RANGE ⁽¹⁾		SPRING PART NUMBER	SPRING COLOR
		bar	psig		
63EGLP	6358EBLP	5.9 to 9.7	85 to 140	17B1261X012	Green
		9.0 to 13.8	130 to 200	17B1263X012	Blue
12.4 to 24.1		180 to 350	17B1264X012	Red	
	6358EBHLP	17.2 to 25.9	250 to 375	17B1263X012	Blue

1. Set pressure plus buildup should not exceed maximum differential pressure of 27.6 bar / 400 psig.

Table 2. Minimum and Maximum Differential Pressures

BODY SIZE		MAIN VALVE SPRING RANGE		MAIN VALVE SPRINGPART NUMBER	MAIN VALVE SPRING COLOR	TYPE 63EGLP			
						Minimum Differential Pressure Required For Full Stroke		Maximum Differential Pressure	
DN	NPS	bar	psig			bar	psig	bar	psig
100	4	5.9 to 25.9	85 to 375	14A6634X012	Red	3.8	55	27.6	400

Main body gasket and mounting studs and nuts are not included but can be ordered separately:

- Tank to Valve studs and nuts mounting kit: MK63EGLP001
- 4 in. Spiral Wound Gasket: ERSA03240A0

Clean out all pipelines before installation of the relief valve and check to be sure the relief valve has not been damaged or has collected foreign material during shipping. For flanged bodies, use suitable line gaskets and approved piping and bolting practices. Install the relief valve in the vertical-up position and be sure flow through the body is in the direction indicated by the arrow on the body.

Overpressure Protection

Refer to the nameplate for the maximum inlet pressure of the relief valve. The relief valve should be inspected for damage after any overpressure condition.

Startup

The relief valve is factory set at the pressure requested. With proper installation completed, slowly increase pressure while using gauges to monitor pressure.

Setpoint Adjustment

Type 63EGLP assemblies shipped with approvals from UL®, from the American Society of Mechanical Engineers (ASME) or with Pressure Equipment Directive (PED) paperwork are not adjustable. Configurations shipped without these approvals are adjustable.

Taking Out of Service (Shutdown)



To avoid personal injury resulting from sudden release of pressure, remove all pressure from upstream of the relief valve and piloting system before attempting disassembly.

Remove all pressure from the upstream system or tank. Release all pressure from the main valve and pilot by opening an upstream vent valve or by slightly loosening one of the compression fittings on the pilot supply tubing or actuator tubing until the trapped pressure starts bleeding out. Once all pressure is released, tighten the compression fitting.

UL® is a mark owned by Underwriters Laboratories.

Parts List

Main Valve

Key	Description
1	Valve Body
2	Body Flange
3	Cap Screw (8 required)
4	Gasket
9	Spring
11	Cage
12	Port Seal
13	Seat Ring
14	Piston Ring
15	Upper Seal
16	Valve Plug
17	Cage O-ring
20	Plug O-ring
21	O-ring
24	Drive Screw (2 required)
25	Flow Arrow
26	Nameplate
27	Plug
31	Pipe Plug (4 required)
45	Pipe Plug (not shown)
46	Deflector (not shown)
47	Drive Screw (2 required) (not shown)

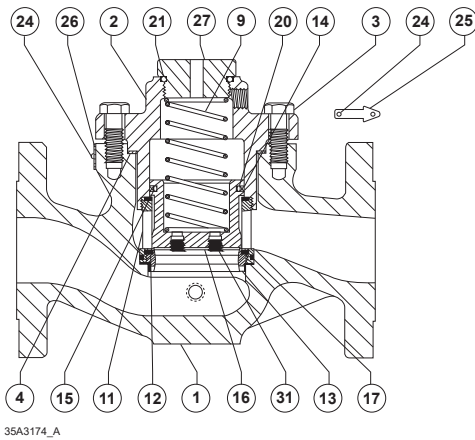

COMPLETE STEEL MAIN VALVE ASSEMBLY

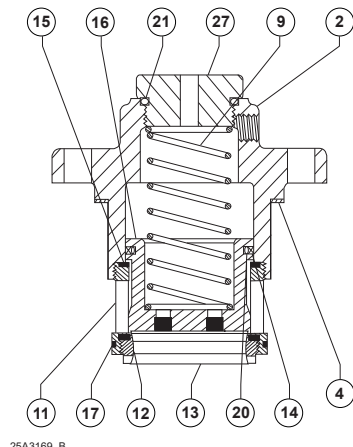

TRIM PACKAGE ASSEMBLY (FOR REFERENCE ONLY)

Figure 1. Type 63EGLP Main Valve

Types 6358EBLP and 6358EBHLP Pilots

Key	Description
1	Pilot Body
2	Spring Case
3	Body Plug
4	Valve Plug Assembly
5	Diaphragm Assembly
6	Connector Cap
7	Control Spring
8	Spring Seat
9	Stem Guide
10	Adjusting Screw
11	Locknut
12	Closing Cap
13	Body Plug O-ring
14	Valve Spring
15	O-ring
16	Vent Assembly (2 required)
17	Machine Screw (6 required)
18	Connector Cap O-ring
20	Restriction
36	Gasket
37	Stem O-ring
38	Lower Spring Seat
40	Diaphragm Limiter for Type 6358EBLP

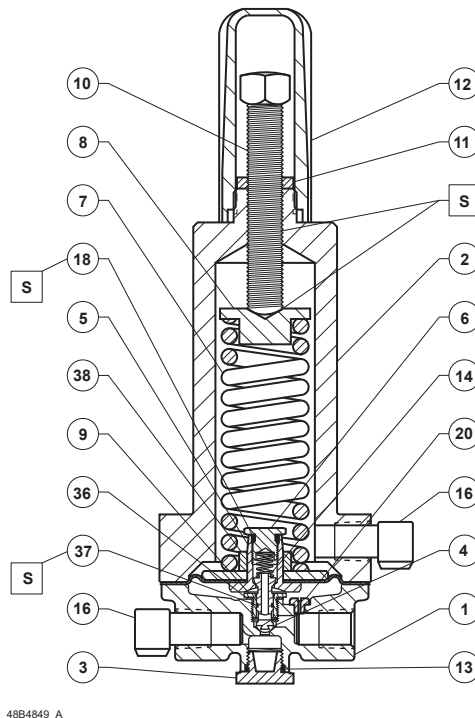

TYPE 6358EBLP PILOT INTERIOR VIEW

APPLY SEALANT (S)

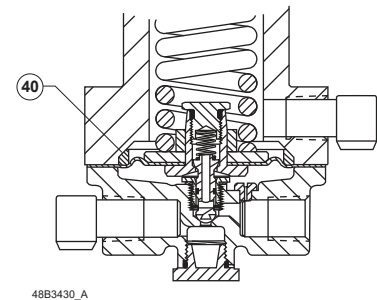

TYPE 6358EBLP PILOT WITH DIAPHRAGM LIMITER FOR 12.4 to 24.1 bar / 180 to 350 psig SET PRESSURE RANGE INTERIOR VIEW

Figure 2. Types 6358EBLP and 6358EBHLP Pilot Assemblies

Type 63EGLP

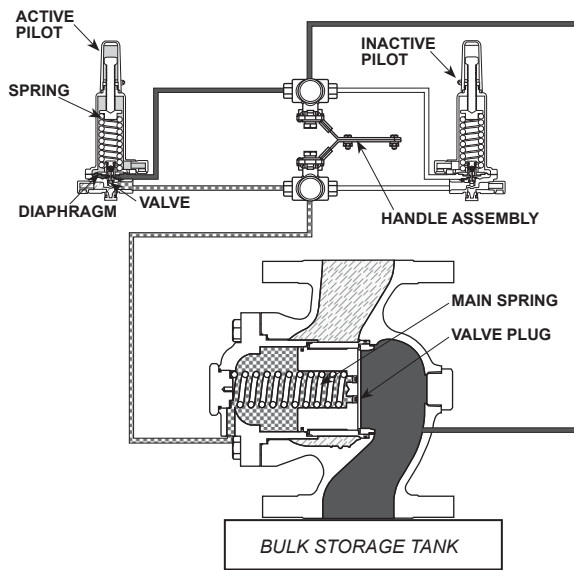

Figure 3. Type 63EGLP Operational Schematics

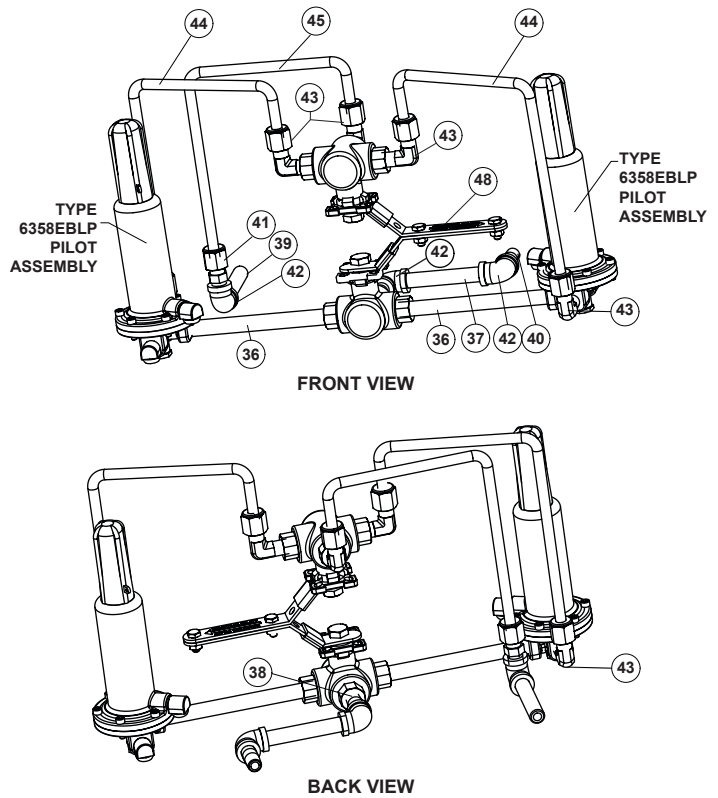

Figure 4. Mounting Parts Assemblies

Mounting Parts

Key	Description
36	Pipe Nipple (2 required)
37	Pipe Nipple
38	Pipe Nipple
39	Pipe Nipple
40	Pipe Nipple
41	Connector
42	Elbow (3 required)
43	Elbow (5 required)
44	Tubing (2 required)
45	Tubing
48	Lever Assembly
49	Lead Seal and Wire (2 required) (not shown)
50	Lifting Sling (not shown)
51	Rain Cap (not shown)
52	Lead Seal and Wire (not shown)

LPG Equipment

Emerson Process Management Regulator Technologies, Inc.

USA - Headquarters
McKinney, Texas 75070 USA
Tel: +1 800 558 5853
Outside U.S. +1 972 548 3574

For further information visit www.fisherregulators.com

The Emerson logo is a trademark and service mark of Emerson Electric Co. All other marks are the property of their prospective owners. Fisher is a mark owned by Fisher Controls International LLC, a business of Emerson Process Management.

The contents of this publication are presented for informational purposes only, and while every effort has been made to ensure their accuracy, they are not to be construed as warranties or guarantees, express or implied, regarding the products or services described herein or their use or applicability. We reserve the right to modify or improve the designs or specifications of such products at any time without notice.

Emerson Process Management Regulator Technologies, Inc. does not assume responsibility for the selection, use or maintenance of any product. Responsibility for proper selection, use and maintenance of any Emerson Process Management Regulator Technologies, Inc. product remains solely with the purchaser.



EMERSON
Process Management