

October 2024

Type 63EG Relief Valve or Backpressure Regulator



WARNING

Failure to follow these instructions or to properly install and maintain this equipment could result in an explosion and/or fire causing property damage and personal injury or death.

Fisher™ relief valves must be installed, operated and maintained in accordance with federal, state and local codes, rules and regulations and Emerson Process Management Regulator Technologies, Inc. (Emerson) instructions.

If a leak develops or if the outlet continually vents gas, service to the unit may be required. Failure to correct trouble could result in a hazardous condition. Only a qualified person must install or service the unit.

Call a gas service person to service the unit. Only a qualified person must install or service the regulator.

Introduction

Scope of the Manual

This instruction manual provides instructions for the installation, maintenance and parts ordering information for a Type 63EG relief valve or backpressure regulator with either a Type 6358, 6358B, 6358EB or 6358EBH pilot and a Type 1098-63EGR relief valve with a Type 6358B pilot. Instructions and parts ordering information for the optional Type 252 or P590 Series pilot supply filters and any other equipment used with these valves are found in separate manuals.

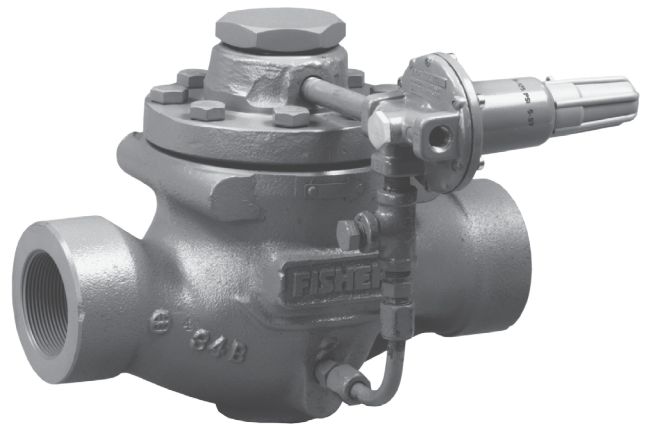

W6955

Figure 1. Type 63EG Relief Valve or Backpressure Regulator



W3003-1*

Figure 2. Type 1098-63EGR Relief Valve

Types 63EG and 1098-63EGR

Specifications

Specifications for various Types 63EG and 1098-63EGR constructions are listed on Specifications section and Tables 1 to 4. The specifications for a given construction as it originally comes from the factory are stamped on nameplates located on the main valve body and the upper diaphragm case of the actuator for a Type 1098-63EGR construction. The pilot control spring range appears on the pilot spring case and the pilot restriction code is indicated by a letter stamped on the bottom of the pilot body next to the tapped side outlet: an S for the red standard-diameter (No. 57 drill size) restriction, an L for the blue large-diameter (No. 47 drill size) restriction for liquid service or an H for the yellow small-diameter (No. 70 drill size), high-gain restriction.

Available Constructions

Type 63EG with a 6358 Series Pilot
 Type 1098-63EGR with a Type 6358B Pilot

Main Valve Body and End Connection Styles⁽¹⁾⁽²⁾

MAIN VALVE BODY SIZE		END CONNECTION STYLES AND RATINGS	
NPS	DN	Cast Iron	Steel or Stainless Steel
1, 2	25, 50	NPT; CL125 FF flanged	NPT; BWE; SWE; CL150 RF, CL300 RF, CL600 RF or PN 16/25/40 flanged
3, 4, 6	80, 100, 150	CL125 FF flanged	BWE; CL150 RF, CL300 RF, CL600 RF or PN 16/25/40 flanged
8 x 6 or 12 x 6	200 x 150 or 300 x 150	----	CL150, CL300, CL600 or BWE

Maximum Relief (Inlet⁽³⁾) Pressure⁽²⁾

Type 63EG: 400 psig / 27.6 bar or body rating, whichever is lower
Type 1098-63EGR: 82 psig / 5.6 bar

Maximum Actuator Pressures⁽²⁾ (Standard Size 40 with Type 1098-63EGR Only)

Set Pressure⁽⁴⁾: 65 psig / 4.5 bar
Operating Pressure⁽³⁾: 75 psig / 5.2 bar
Emergency Casing Pressure: 82 psig / 5.6 bar

Relief Set Pressure/Backpressure Control Ranges⁽⁴⁾

See Table 1

Main Valve Port Diameters and Valve Plug Travels

BODY SIZE		PORT DIAMETER		VALVE PLUG TRAVEL	
NPS	DN	In.	mm	In.	mm
1	25	1.31	33	0.75	19
2	50	2.38	60	1.13	29
3	80	3.38	86	1.50	38
4	100	4.38	111	2.00	51
6, 8 x 6 and 12 x 6	150, 200 x 150 and 300 x 150	7.19	183	2.00	51

Main Valve Flow Characteristic

Linear (**standard**), Quick-Open (optional) or Whisper Trim™ III (optional)

Main Valve Flow Direction

Up through seat ring and out through cage

Process Temperature Capabilities⁽²⁾

Nitrile (NBR): -20 to 180°F / -29 to 82°C
Fluorocarbon (FKM): 0 to 300°F / -18 to 149°C
 Water is limited to 0 to 180°F / -18 to 82°C
Ethylene propylene (EPR): -20 to 275°F / -29 to 135°C
Perfluoroelastomer (FFKM): 0 to 425°F / -18 to 218°C

Options

- Aluminum or Stainless steel Type 252 pilot supply filter
- Brass Type P594-1 filter
- Pressure gauges⁽⁵⁾
- NACE Construction

Approximate Weights (including pilot)

Type 63EG

NPS 1 / DN 25: 35 lbs / 16 kg
NPS 2 / DN 50: 55 lbs / 25 kg
NPS 3 / DN 80: 95 lbs / 43 kg
NPS 4 / DN 100: 145 lbs / 66 kg
NPS 6 / DN 150: 330 lbs / 150 kg
NPS 8 x 6 / DN 200 x 150: 670 lbs / 304 kg
NPS 12 X 6 / DN 300 X 6: 1150 lbs / 521 kg

Type 1098-63EGR

NPS 1 / DN 25: 65 lbs / 29 kg
NPS 2 / DN 50: 85 lbs / 39 kg
NPS 3 / DN 80: 125 lbs / 57 kg
NPS 4 / DN 100: 175 lbs / 79 kg
NPS 6 / DN 150: 360 lbs / 163 kg
NPS 8 x 6 / DN 200 x 150: 700 lbs / 318 kg
NPS 12 X 6 / DN 300 X 6: 1180 lbs / 535 kg

1. EN (or other) ratings and end connections can usually be supplied; consult your local Sales Office.

2. The pressure and/or temperature limits listed in this Instruction Manual and any applicable standard limitation should not be exceeded.

3. Includes buildup.

4. Set pressure is defined as the pressure at which the pilot starts-to-discharge.

5. Consult your local Sales Office for information on available gauges and units of measurement.

Types 63EG and 1098-63EGR

Table 1. Relief Set Pressure and Backpressure Control Ranges

TYPE	PILOT TYPE	RELIEF SET PRESSURE RANGE ⁽¹⁾		SPRING PART NUMBER	SPRING COLOR	SPRING WIRE DIAMETER		SPRING FREE LENGTH	
		psig	bar			In.	mm	In.	mm
63EG	6358	10 to 40	0.69 to 2.8	1E392527022	Yellow	0.148	3.76	2.00	50.8
		35 to 125	2.4 to 8.6	1K748527202	Red	0.187	4.75	2.19	55.6
	6358B	10 to 30	0.69 to 2.1	1B788327022	Silver	0.142	3.61	2.13	54.1
		30 to 60	2.1 to 4.1	1B788427022	Blue	0.182	4.62	1.94	49.3
		60 to 125	4.1 to 8.6	1K748527202	Red	0.187	4.75	2.19	55.6
6358EB	85 to 140	5.9 to 9.6	17B1261X012	Green	0.225	5.72	3.70	94.0	
	130 to 200	9.0 to 13.8	17B1263X012	Blue	0.262	6.65	3.85	97.8	
	180 to 350	12.4 to 24.1	17B1264X012	Red	0.294	7.47	4.22	107	
6358EBH	250 to 400	17.2 to 27.6	17B1263X012	Blue	0.262	6.65	3.85	97.8	
1098-63EGR	6358B	3 to 18	0.21 to 1.2	1B986027212	Green	0.120	3.05	2.12	53.8
		15 to 40	1.0 to 2.8	1E392527022	Yellow	0.148	3.76	2.00	50.8
		35 to 65	2.4 to 4.5	1K748527202	Red	0.187	4.75	2.19	55.6

1. Set pressure plus buildup should not exceed maximum differential pressure of 400 psig / 27.6 bar.

Product Description

Types 63EG and 1098-63EGR pilot-operated pressure relief valves may be used for both liquid and gas service. The Type 63EG is also suitable for throttling backpressure or bypass applications. The main valves in both constructions use a quick-change trim package for fast maintenance.

Pilot Descriptions

The following pilot configurations are available for the Type 63EG or 1098-63EGR relief valve or backpressure regulator.

Relief Valve

For relief valve application use a Type 6358B, 6358EB or 6358EBH relief pilot. The pilot bleeds constantly while the relief valve is in operation. The pilot does not bleed when inlet pressure is below set pressure. The pilot exhaust can be connected directly to the main valve exhaust pipe if the pilot connection and the exhaust pipe are designed to prevent significant backpressure buildup during full-flow conditions.

Type 6358B—Set pressure range from 10 to 125 psig / 0.69 to 8.62 bar in two ranges. This pilot is available with a high, medium or low-gain restriction.

Type 6358EB—Set pressure range of 85 to 350 psig / 5.86 to 24.1 bar in three ranges. This pilot is available with a high or low-gain restriction.

Type 6358EBH—Set pressure range of 250 to 400 psig / 17.2 to 27.6 bar in two ranges. This pilot is available with a high or low-gain restriction.

Backpressure Regulator

The **Type 6358** is a low bleed pilot, so it only exhausts while it is repositioning the main valve. There is no constant bleed with this construction which is useful for backpressure applications where minimizing emissions is important and the pilot exhaust can not be piped to the downstream piping. This also minimizes dirt buildup in the pilot. The Type 6358 has a set pressure range of 10 to 125 psig / 0.69 to 8.62 bar in two ranges. The Types 6358B, 6358EB and 6358EBH relief pilots can also be used in backpressure applications but they will exhaust any time inlet pressure is above setpoint.

Principle of Operation

A pressure relief valve is a throttling pressure control device that opens and closes to ensure the upstream pressure does not rise above a predetermined pressure. A backpressure regulator is a device that controls and responds to changes in the upstream pressure. It functions the same as a relief valve in that it opens on increasing upstream pressure.

The Types 63EG and 1098-63EGR relief valves are not ASME safety relief valves.

Type 63EG

Relief Valve

As long as the inlet pressure is below the set pressure, the Type 6358B, 6358EB or 6358EBH pilot control spring keeps the pilot valve plug closed. Inlet pressure passes through the pilot restriction and through the hollow passage of the valve plug then registers as

Types 63EG and 1098-63EGR

Table 2. Minimum and Maximum Differential Pressures

BODY SIZE		MAIN VALVE SPRING RANGE		MAIN VALVE SPRING PART NUMBER	MAIN VALVE SPRING COLOR	TYPE 63EG				TYPE 63EG WITH TYPE 1098 SIZE 40 ACTUATOR			
						Minimum Differential Pressure Required For Full Stroke		Maximum Differential Pressure		Minimum Differential Pressure Required For Full Stroke		Maximum Differential Pressure	
						psig	bar	psig	bar	psig	bar	psig	bar
1	25	30 to 125 85 to 400	2.1 to 8.6 5.9 to 27.6	14A9687X012 14A9679X012	Green Red	70 150	4.8 10.3	125 400	8.6 27.6	2.5 -----	0.17 -----	60 -----	4.1 -----
2	50	10 to 40 30 to 125 85 to 400	0.69 to 2.8 2.1 to 8.6 5.9 to 27.6	14A6768X012 14A6626X012 14A6628X012	Yellow Green Red	22 30 90	1.5 2.1 6.2	40 125 400	2.8 8.6 27.6	2 3 -----	0.14 0.21 -----	20 60 -----	1.4 4.1 -----
3	80	10 to 40 30 to 125 85 to 400	0.69 to 2.8 2.1 to 8.6 5.9 to 27.6	14A6771X012 14A6629X012 14A6631X012	Yellow Green Red	19 25 60	1.3 1.7 4.1	40 125 400	2.8 8.6 27.6	2.5 4 -----	0.17 0.28 -----	20 60 -----	1.4 4.1 -----
4	100	10 to 40 30 to 125 85 to 400	0.69 to 2.8 2.1 to 8.6 5.9 to 27.6	14A6770X012 14A6632X012 14A6634X012	Yellow Green Red	16 20 55	1.1 1.4 3.8	40 125 400	2.8 8.6 27.6	3.5 5 -----	0.24 0.34 -----	20 60 -----	1.4 4.1 -----
6, 8 x 6 and 12 X 6	150, 200 x 150 and 300 X 150	10 to 40 30 to 125 85 to 400	0.69 to 2.8 2.1 to 8.6 5.9 to 27.6	15A2253X012 14A9686X012 15A2615X012	Yellow Green Red	16 20 55	1.1 1.4 3.8	40 125 400	2.8 8.6 27.6	6 9.5 -----	0.41 0.66 -----	20 60 -----	1.4 4.1 -----

loading pressure on top of the main valve plug. Force from the main spring, in addition to pilot loading pressure, provides downward loading pressure to keep the main valve plug tightly closed.

When the inlet pressure rises above the set pressure, the pressure on the pilot diaphragm overcomes the control spring and opens the valve plug. The pilot then exhausts the loading pressure from the top of the main valve plug. The pilot continuously exhausts gas while inlet pressure is above the set pressure. The inlet pressure unbalance overcomes the main spring force and opens the plug.

As the inlet pressure drops below the set pressure, the pilot control spring closes the pilot valve plug and the exhaust to atmosphere stops. Force from the main spring, along with pilot loading pressure, pushes the plug onto the seat, producing tight shutoff.

Backpressure Regulator

As long as inlet pressure remains below set pressure, the Type 6358 pilot control spring keeps the pilot valve plug closed. Inlet pressure bleeds around the upper portion of the pilot valve plug and then through the hollow passage of that valve plug to produce loading pressure on the main valve plug. This loading pressure along with force from the main spring provides the pressure to keep the main valve plug tightly closed.

When inlet pressure rises above the set pressure, the pressure on the pilot diaphragm overcomes the control spring to close the upper portion of the valve plug and stroke the valve plug to open the lower port. The pilot exhausts loading pressure from the top of the main valve plug. Inlet pressure unbalance overcomes the main spring force to open the plug.

While the main valve is throttling, the upper port of the pilot stays closed. The pilot exhausts only when it repositions the main valve. As inlet pressure drops below setpoint, the pilot control spring overcomes the diaphragm force to stroke the valve plug down to close the lower port and open the upper port. Force from the main spring, along with pilot loading pressure, builds up to close the main valve plug.

Type 1098-63EGR Relief Valve

As long as inlet pressure remains below set pressure, the Type 6358B pilot control spring keeps the pilot valve plug closed. Inlet pressure bleeding through the pilot restriction and the hollow passage of the valve stem loads the stem side of the actuator diaphragm, balancing the actuator and letting the main valve spring keep the main valve plug tightly shutoff.

An inlet pressure rise above the set pressure overcomes the pilot control spring and opens the pilot valve plug. Loading pressure bleeds out the pilot

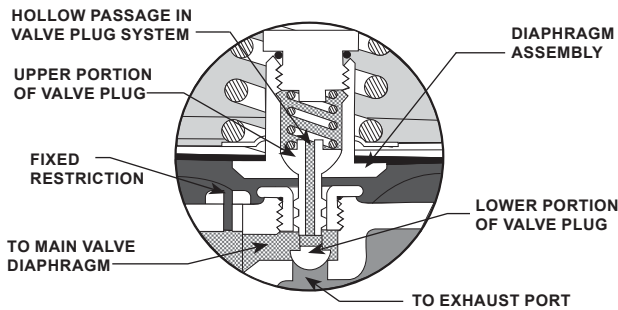

EXPANDED VIEW OF THE TYPE 6358B RELIEF PILOT DIAPHRAGM ASSEMBLY AND VALVE PLUG

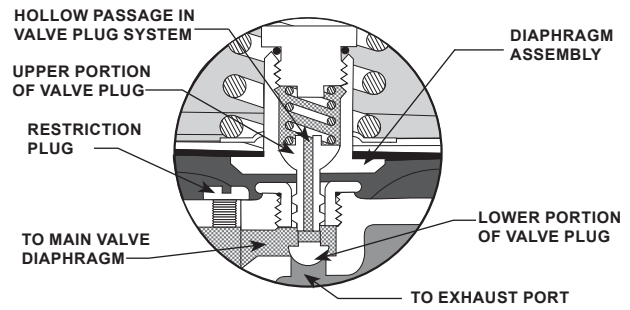

EXPANDED VIEW OF THE TYPE 6358 BACKPRESSURE PILOT DIAPHRAGM ASSEMBLY AND VALVE PLUG

Figure 3. Type 6358B Operational Schematic

Figure 4. Type 6358 Operational Schematic

exhaust faster than it can be replaced through the pilot restriction. The pilot continuously exhausts gas while inlet pressure is above the set pressure. This permits inlet pressure to unbalance the actuator diaphragm and push the actuator stem against the main valve plug causing it to open.

As inlet pressure drops back to set pressure, the pilot control spring closes the pilot valve plug. Loading pressure again builds up to balance the actuator and let the main valve plug close.

Additionally, physical damage to the relief valve could break the pilot off the main valve, causing personal injury and property damage due to escaping gas. To avoid such injury or damage, install the unit in a safe location.

Note

On the Type EGR main valve, normal pressure drop assists shutoff. Therefore, leakage may result during any reverse pressure drop condition.

Installation

WARNING

Personal injury, equipment damage or leakage due to escaping gas or bursting of pressure-containing parts may result if the relief valve is installed where its capabilities can be exceeded or where conditions exceed any ratings of the adjacent piping or piping connections.

To avoid injury or damage, install a Type 63EG or 1098-63EGR relief valve where: Service conditions are within unit capabilities (including those given in the Specifications section) and service conditions are within applicable codes, regulations or standards.

1. Use qualified personnel when installing, operating and maintaining regulators. Before installing, inspect the main valve, pilot and tubing for any shipment damage or foreign material that may have collected during crating and shipment. Make certain the body interior is clean and the pipelines are free of foreign material. Apply pipe compound only to the male pipe threads with a NPT body or use suitable line gaskets and good bolting practices with a flanged body.
2. A Type 63EG or 1098-63EGR may be installed in any orientation, as long as flow through it matches the direction of the arrow on the main valve body. An upstream control line is not required because of the integral pilot supply tubing (key 28, Figure 12). However, for remote upstream registration, this tubing may be disconnected from

Types 63EG and 1098-63EGR

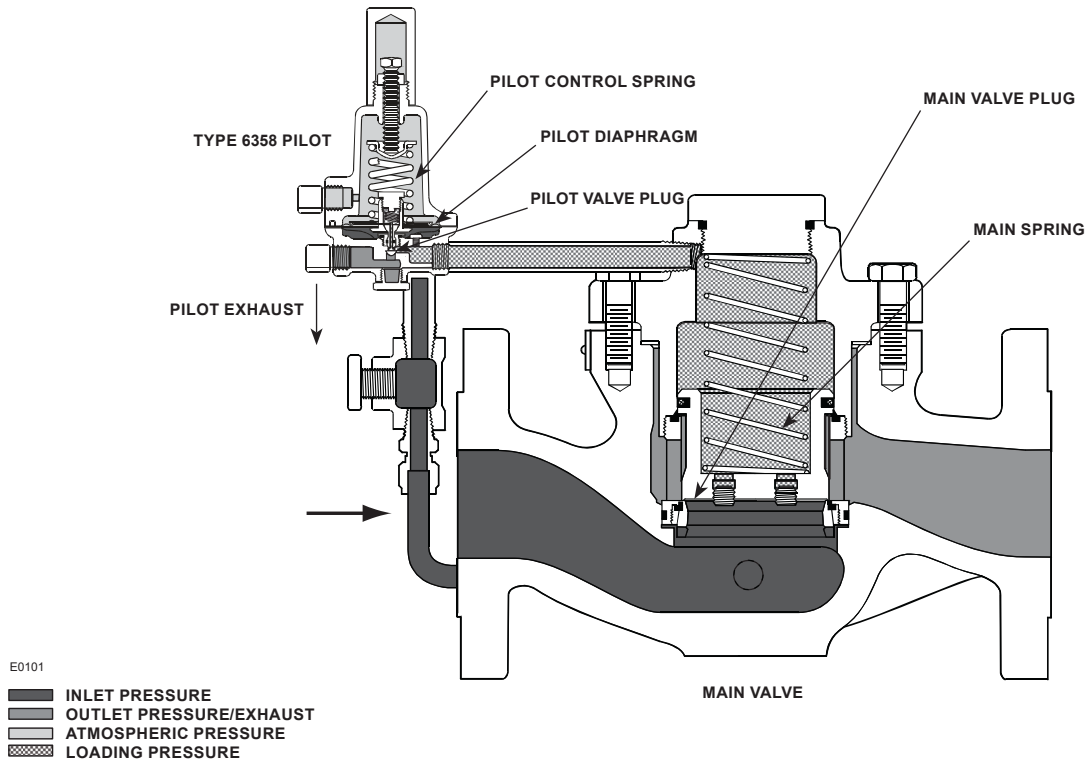

Figure 5. Type 63EG Operational Schematic

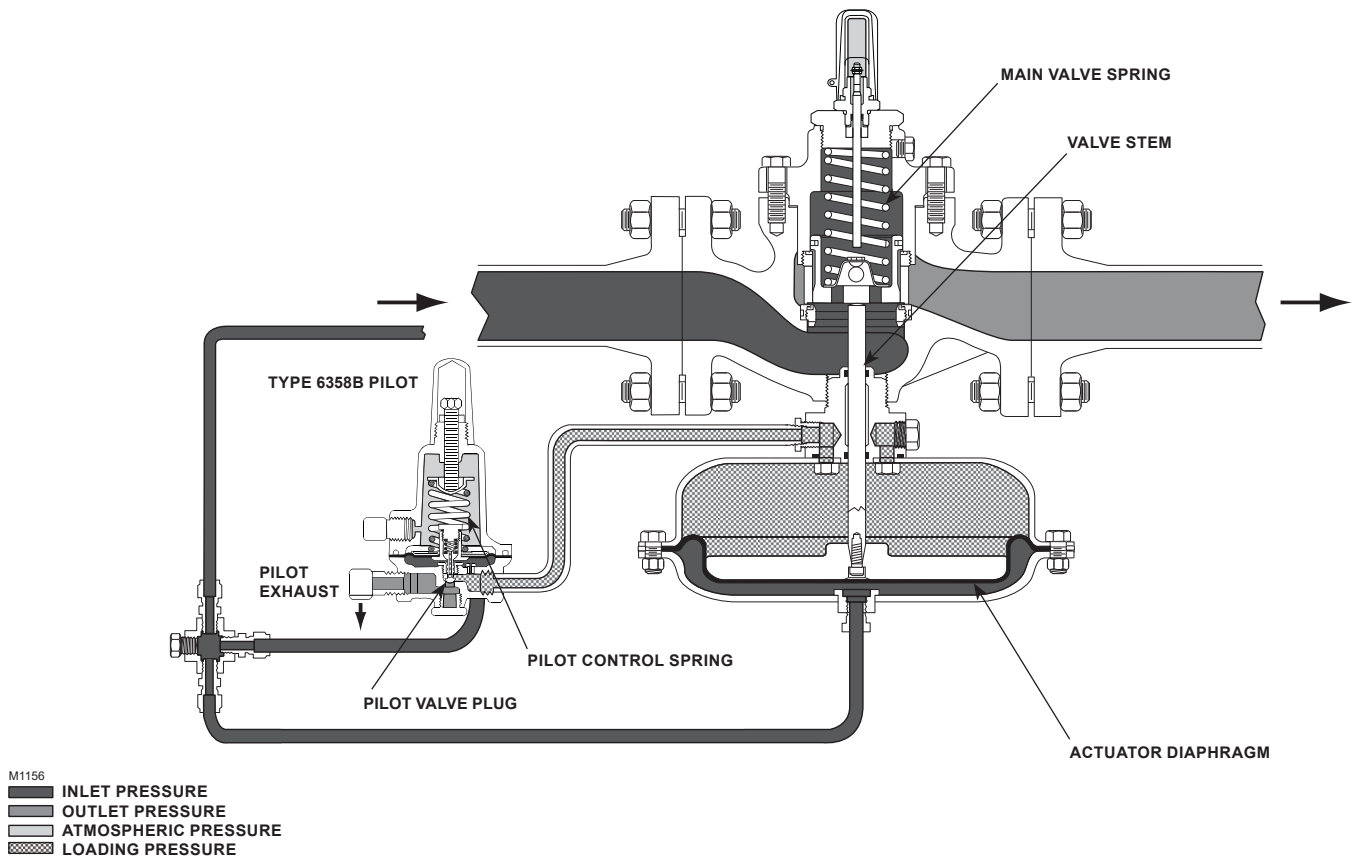

Figure 6. Type 1098-63EGR Operational Schematic

the main valve and from the pipe tee (key 24, Figure 12) or pipe cross (key 35, Figure 12) as long as the 1/4 in. NPT tapping in the side of the main valve body is plugged.



WARNING

Types 63EG and 1098-63EGR relief valves vent gas from the main valve outlet and from the pilot exhaust. In hazardous or flammable gas service, personal injury, death or property damage may occur due to fire or explosion of accumulated vented gas. To prevent such injury or damage, vent the gas to a safe location. Design and install exhaust piping to guard against excessive flow restriction. Protect this piping from condensation or debris that can clog it.

For shutdown safety on backpressure applications, install vent valves immediately upstream and downstream of the main valve.

3. If system operation is necessary during maintenance or inspection, install isolating and vent valves as needed. If upstream protection is not provided for the entire unit, an optional P590 Series or Type 252 pilot supply filter installed upstream of the pilot may help protect it from clogging.
4. A relief valve always must be installed so that the pilot will exhaust properly and into a safe place. The pilot spring case vent must be kept open to atmospheric pressure. Protect this vent from icing, moisture or other blockage as required. If the pressed-in vent assembly (key 27, Figure 12 or 13) remains in the pilot exhaust port (connection A, Figure 7), it must be pointed down if possible or otherwise protected.
5. If the exhaust is to be piped to the main valve outlet or remotely vented, remove the vent assembly and install obstruction-free tubing or piping with a minimum number of bends into the 1/4 in. NPT pilot exhaust connection. Provide protection on a remote vent by installing a screened vent cap into the remote end of the vent pipe.

6. If using pipe, apply a good grade of pipe compound to the male pipe threads before making the connection. Install tubing or piping into the appropriate pilot connection.
7. Set pressure is defined as the pressure at which the pilot starts-to-discharge. The set pressure of a unit is adjusted by changing the control spring compression on the pilot.
8. The pilot is factory-set for the set pressure specified on the order. If no setting is specified, set pressure is factory-set at midrange of the spring range.

Startup and Adjustment

Key numbers are referenced in Figure 12.

1. With proper installation and adjustment completed, slowly open the upstream shutoff valve while using gauges to monitor pressure. On backpressure applications using an isolating bypass, also open the downstream shutoff valve and close the bypass valve. Inlet pressure may be monitored either by using the optional installed gauge (key 29) or by removing the pipe plug (key 29) and temporarily installing a gauge.
2. If set pressure adjustment is necessary, monitor inlet pressure with a gauge during adjustment.

Adjustment

Key numbers are referenced in Figures 14 and 15. The 6358 Series relief pilots are adjusted by removing the closing cap (key 12), loosening the locknut (key 11) and turning the adjusting screw (key 10) clockwise to increase or counterclockwise to decrease the set pressure. When the required set pressure is maintained for several minutes, tighten the locknut to lock the adjusting screw and install the closing cap.

Shutdown

Relief Installations

Slowly close the upstream shutoff valve. Release all pressure from the main valve and pilot by opening the upstream vent valve or by slightly loosening one of the compression fittings on the pilot supply tubing or actuator tubing until the trapped pressure starts bleeding out. Once all pressure is released, tighten the compression fitting.

Types 63EG and 1098-63EGR

Backpressure Installations

Slowly close the upstream shutoff valve while opening the bypass valve. Then close the downstream shutoff valve and open both vent valves to release all pressure from the main valve and pilot.

Maintenance

Relief valve parts are subject to normal wear and must be inspected and replaced as necessary. The frequency of inspection and replacement of parts depends upon the severity of service conditions or the requirements of local, state and federal regulations.

Due to the care Emerson takes in meeting all manufacturing requirements (heat treating, dimensional tolerances, etc.), use only replacement parts manufactured or furnished by Emerson.

Lubricate the stem O-rings on the Type 1098 actuator annually, using the grease fitting (key 28, Figure 13). Stem O-rings can be checked for damage during normal operation by line pressure leakage or unexpected grease extrusion from the actuator vent (key 27, Figure 13). Unless otherwise specified, lubricate all O-rings, gaskets and seals with a good grade of general-purpose grease and install gently rather than force into position. Update nameplates to accurately indicate any field changes in equipment, materials, service conditions or pressure settings.



WARNING

Avoid personal injury or damage to property from sudden release of pressure or uncontrolled gas or other process fluid. Before starting disassembly: isolate the relief valve from system pressure, release all internal pressure and vent the pilot(s) and main valve diaphragm loading pressure.

Type 63EG or 63EGR Main Valve

Replacing Quick-Change Trim Package

Perform this procedure if the entire trim package (Figure 10 or 11) or only the gasket or cage O-ring (key 4 or 17, Figure 10 or 11) will be replaced if exposed surfaces of the trim package or body interior will be inspected or cleaned. Key numbers for both the complete Type 63EG main valve and its trim package

are referenced in Figure 10. Key numbers for both the complete Type 63EGR main valve and its trim package are referenced in Figure 11. Replacement trim package assembly numbers are listed in the parts list.

Note

All disassembly, trim change and reassembly steps in this section may be performed with the relief valve in the main line. The pilot and its pipe nipple need not be removed for trim package replacement with the Type 63EGR main valve but must be removed with the Type 63EG main valve.

1. Remove the cap screws (key 3) on a cast iron or steel body or remove the stud bolt nuts (key 29, not shown) on a Stainless steel body. Pry the body flange (key 2) loose from the valve body (key 1) and lift out the trim package.
2. Perform any required inspection, cleaning or maintenance on the exposed surfaces of the body interior or trim package. Replace the gasket (key 4) or cage O-ring (key 17) as necessary.
3. On a factory-built replacement trim package with indicator assembly, check indicator zeroing by unscrewing the indicator protector (key 19) and seeing if the flange on the indicator nut (key 22) lines up evenly with the bottom marking on the indicator scale (key 18). If not, remove the indicator scale and separate the indicator nut and hex nut (key 8). Hold the indicator scale against the indicator fitting (key 5) with the scale base resting against the shoulder of the fitting and turn the indicator nut until its flange is aligned with the bottom scale marking. Then lock both nuts against each other and install the indicator scale and protector.

Note

In the following step a Type 63EG trim package must be installed so the body flange and body side tappings are aligned, but a Type 63EGR trim package requires no special orientation in the body.

- Coat the cage seating surfaces of the valve body web and the body flange seating surfaces of the valve body neck with a good grade of general-purpose grease. Install the trim package and secure it evenly with the cap screws or hex nuts. With a Type 63EG main valve, install the pilot and its pipe nipple and connect the pilot supply tubing.

Replacing Trim Parts

Perform this procedure if inspecting, cleaning or replacing individual parts in a trim package. Key numbers for the Type 63EG main valve are referenced in Figure 10. Key numbers for the Type 63EGR main valve are referenced in Figure 11. Both types are available with travel indicator, even though travel indicator key numbers are referenced only in Figure 11.

Note

Access to the spring (key 9), flange O-ring (key 21) or travel indicator parts, in step 1 can be gained without removing the body flange (key 2).

- Remove the flange plug and spring (keys 27 and 9) or the travel indicator assembly by removing lower indicator fitting (key 5) from the body flange (key 2). Proceed to step 5 if maintenance on only the travel indicator parts is needed and then proceed to step 11 for reassembly instructions.
- Remove the cap screws (key 3) on a cast iron or steel body or remove the stud bolt nuts (key 29, not shown) on a Stainless steel body and (after removing the pilot and pipe nipple from a Type 63EG main valve) pry the body flange loose from the valve body (key 1).
- Use the valve body as a holding fixture if desired. Flip the body flange over and anchor it on the valve body as shown in Figure 9, removing the pipe plug (key 31) first if necessary.
- To gain access to the port seal (key 12), upper seal (key 15) or valve plug parts, unscrew the seat ring (key 13) from the cage (key 11) and the cage from the body flange. For leverage, a wrench handle or similar tool may be inserted into the orifice slots (Figure 9) and a strap wrench may be wrapped around a standard or a Whisper Trim™

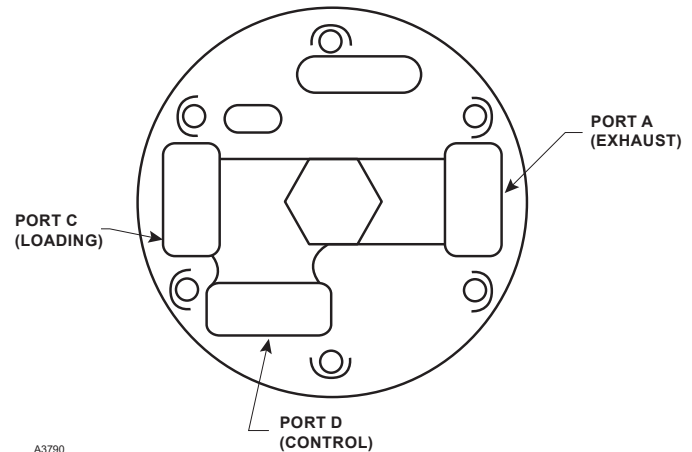

- A3790
- PORT A (EXHAUST) —THE MAIN VALVE LOADING PRESSURE IS DISCHARGED TO THE MAIN VALVE OUTLET OR TO ATMOSPHERE PRESSURE.
 - PORT C (LOADING) —A LOADING PRESSURE SIGNAL IS SENT FROM THIS PORT TO THE MAIN VALVE DIAPHRAGM CASING.
 - PORT D (CONTROL) —THE MAIN VALVE INLET PRESSURE IS SENSED AT THIS PORT.

Figure 7. Pilot Port Functions

- cage or a soft bar may be inserted through the windows of a standard cage. To remove the piston ring (key 14) and/or plug O-ring (key 20), remove the valve plug (key 16) from the body flange, insert a screwdriver into the precut fold over area of the piston ring and unfold the piston ring. Proceed to step 6 if no further maintenance is necessary.
- To gain access to a part in the travel indicator assembly, remove the indicator protector (key 19) and indicator scale (key 18). Since some compression is left in the spring, carefully remove the flanged nut (key 22) and hex nut (key 8). A screwdriver may be inserted through the press-fit O-ring retainer (key 6) to remove the stem O-ring without removing the O-ring retainer. If necessary, unclip the E-ring from the indicator stem.
- Thoroughly clean and inspect all parts before reassembling. For proper operation, a Type 63EG valve plug must have pipe plugs (key 32, Figure 12) installed in all four balancing ports, but a Type 63EGR valve plug must have these balancing ports left open.
- Apply a minimal amount (2 to 3 drops) of silicon oil to the port seal (key 12) and install it flat side down in the gland in the seat ring (key 13). Run a finger

Types 63EG and 1098-63EGR



W3012

Figure 8. Easy-Maintenance Trim

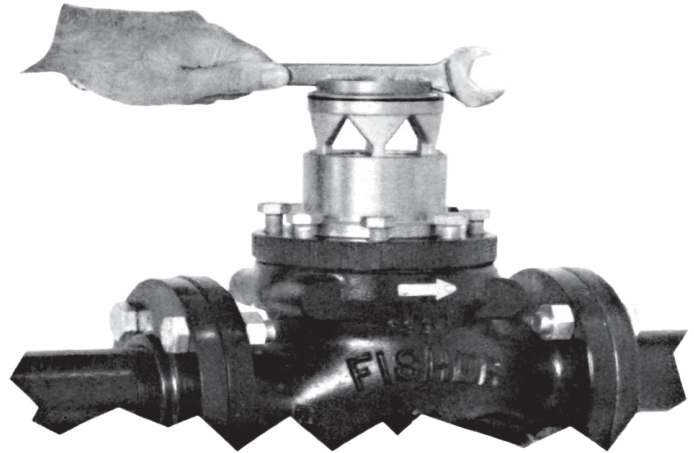

W2772

Figure 9. Seat Ring and/or Cage Removal Using Body as a Holding Fixture

around the port seal (key 12) until it is completely flat to remove any trapped air. Lubricate the seat ring threads and firmly tighten the seat ring (key 3) into the cage (key 11) using a bar. Use a back and forth motion during tightening to ensure the seal doesn't wrinkle. Back out the seat ring (key 13) 1 in. / 2.5 cm after tightening.

8. Install the plug O-ring (key 20) and piston ring (key 14) onto the valve plug (key 16). Insert the valve plug into the body flange (key 2).
9. Apply a minimal amount (2 to 3 drops) of silicon oil to the upper seal (key 15) and install it flat side down in the gland in the cage (key 11). Run a finger around the upper seal (key 15) until it is completely flat to remove any trapped air. Lubricate the cage threads and using a bar or strap wrench, firmly tighten the cage (key 11) into the body flange (key 2). Use a back and forth motion during tightening to ensure the seal doesn't wrinkle. Back out the cage (key 11) 1 in. / 2.5 cm after tightening.
10. Remove the upside-down body flange if it was anchored on the body. Coat the cage seating surfaces of the valve body web and the body flange seating surfaces of the valve body neck with a good grade of general-purpose grease. Install the body flange on the body and secure it evenly with the cap screws or hex nuts. With a Type 63EG main valve, install the pilot and its pipe nipple and connect the pilot tubing.

Table 3. Type EGR Main Valve Cap Screw (key 3) Torque

SIZE		TORQUE	
NPS	DN	Ft-Lbs	N•m
1	25	75 to 95	102 to 129
2	50	55 to 70	75 to 95
3	80	100 to 130	136 to 176
4	100	160 to 200	217 to 271
6, 8 x 6, 12 x 6	150, 200 x 150, 300 x 150	275 to 300	373 to 407

11. **On a main valve without travel indicator,** install the spring (key 9) and make sure the flange O-ring (key 21) is installed on the flange plug (key 27). Install the flange plug; if necessary, compress the spring with it enough to ensure secure engagement of plug and body flange threads before continuing with final tightening of the plug.

On a main valve with travel indicator, make sure the flange and stem O-rings (keys 21 and 7) and the O-ring retainer (key 6) are installed in the indicator fitting (key 5). Orient the spring seat (key 28) as shown in Figure 11 and attach it with the E-ring (key 23) to the slotted end of the indicator stem (key 10). Install the spring (key 9) on the spring seat.

12. Being careful not to cut the stem O-ring with the stem threads, install the indicator fitting (key 5) down over the indicator stem (key 10) until resting on the spring. Install the hex nut (key 8) and then the flanged indicator nut (key 22) on the indicator stem, pushing on the fitting if necessary to provide sufficient stem thread exposure. To maintain clearance for indicator part installation, draw up the spring seat by turning the hex nut down on the stem until the threads bottom.
13. Install the indicator fitting (key 5) with attached parts into the body flange (key 2). Back the hex nut off (key 8) until the spring completely closes the valve plug against the port and upper seals, as indicated by stem threads showing between this nut and the fitting. Hold the indicator scale (key 18) against the fitting with the scale base resting against the shoulder of the fitting and turn the indicator nut (key 22) until its flange is aligned with the bottom scale marking. Then lock both nuts against each other and install the indicator scale and protector (keys 18 and 19).

Type 1098 Actuator and Pilot Mounting

Perform this procedure if changing the actuator or inspecting, cleaning or replacing actuator and/or pilot mounting parts. Actuator part key numbers are referenced in Figure 13 and mounting part key numbers in Figure 12 unless otherwise indicated.

1. The actuator and pilot(s) may be removed and replaced as a unit by disconnecting the pilot supply tubing (key 28) from the main valve.
2. Access to all internal parts except the stem O-rings, bearings and wiper ring (keys 6, 56 and 57) may be gained without removing the bonnet (key 3) or upper diaphragm case (key 2) from the main valve or the pilot(s) from the bonnet pipe nipple (key 22). Disconnect the actuator tubing (key 33) from the connector fitting (key 25).
3. Remove the cap screws (key 10), nuts (key 11), lower diaphragm case (key 1), diaphragm (key 7) and diaphragm plate (key 8). To separate the stem (key 12) from the diaphragm plate (key 8), remove the stem cap screw (key 9).
4. To remove the case O-ring (key 5), unscrew the four case cap screws (key 4), remove the upper diaphragm case (key 2) and remove the case O-ring.

5. Lubricate both stem O-rings (key 6) and wiper ring (key 57). Install them with the stem bearings (key 56) in the bonnet (key 3). Lubricate the case O-ring (key 5) and install it in the bonnet (key 3). Line up the upper diaphragm hole with the holes in the bonnet; insert and tighten the four case cap screws. Thread the bonnet into the main valve body.
6. Secure the diaphragm plate to the stem with the stem cap screw (key 9). Lay the entire diaphragm, diaphragm plate and stem assembly into the lower diaphragm case so the diaphragm convolution laps up over the diaphragm plate according to Figure 13. Then install the stem slowly up into the bonnet to prevent stem or O-ring damage and secure the lower diaphragm case to the upper diaphragm case with the cap screws and nuts. Tighten the cap screws and nuts evenly in a crisscross pattern to avoid crushing the diaphragm.
7. Grease the stem O-rings through the grease fitting (key 28) until excess grease starts coming out the vent (key 27).
8. Install the pipe nipple(s) and pilot(s) if they were removed during maintenance. Connect the actuator and pilot supply tubing if they were disconnected.

6358 Series Pilots

Key numbers are referenced in Figures 14 and 15. The pilot may remain on the pipe nipple (key 22, Figure 12) during maintenance.



WARNING

Avoid personal injury or damage to property from sudden release of pressure or uncontrolled gas or other process fluid. Before starting to disassemble, carefully release all pressures according to the shutdown procedure. Use gauges to monitor inlet, loading and outlet pressures while releasing these pressures.

Disassembly

1. If necessary to check the outlet end of the body cavity and the seating surfaces for moisture or debris, remove the body plug (key 3) and body plug O-ring (key 13) from the body (key 1).

Types 63EG and 1098-63EGR

2. Remove the closing cap (key 12), loosen the locknut (key 11) and back out the adjusting screw (key 10) until compression is removed from the control spring (key 7).
3. Remove the machine screws (key 17) and separate the spring case (key 2) from the body assembly. Remove the control spring seat (key 8), the control spring (key 7) and, if used, the diaphragm limiter (key 40).
4. Lift out the diaphragm assembly (key 5) and valve plug (key 4). Check the stem guide (key 9) and restriction (key 20) for damage or plugging. The Type 6358 has a restriction plug, not a restriction.
5. If necessary to replace the diaphragm assembly, the valve plug (key 4), the valve spring (key 14) or the stem O-ring (key 37), remove the connector cap (key 6) and connector cap O-ring or gasket (key 36) from the top of the diaphragm assembly.

Assembly

1. If removed, install the body plug O-ring (key 13) over the body plug (key 3) and install the body plug into the body (key 1).
2. Install the stem guide (key 9), if removed and make sure to install the connector cap O-ring or gasket (key 36) between the body (key 1) and the stem guide.

Note

In step 3, if installing a different size restriction, be sure to remove the code letter on the bottom of the pilot and indicate the new letter.

3. If the restriction or restriction plug (key 20) was removed, coat the threads with lubricant and install it.
4. If replacing the stem O-ring (key 37), sparingly apply lubricant and install the O-ring over the valve plug (key 4).
5. If removed, install the valve plug (key 4) and valve spring (key 14) into the diaphragm assembly (key 5). Install a replacement connector cap O-ring or gasket (key 36) on the diaphragm assembly and secure with the connector cap (key 6).

6. Install the diaphragm assembly (key 5) and push down on it to see if the valve plug (key 4) moves smoothly. The diaphragm assembly should stroke approximately 1/16 in. / 159 mm after the valve plug contacts the port.

Note

In step 7, if installing a control spring of a different set pressure range, be sure to remove the set pressure range on the spring case and indicate the new range.

7. Stack the control spring (key 7), the control spring seat (key 8) and, if used, the diaphragm limiter (key 40) onto the diaphragm assembly (key 5). Make sure to install the diaphragm limiter beveled side up.
8. Install the spring case (key 2) on the body (key 1) with the vent assembly (key 16) oriented to prevent clogging or entrance of moisture. Install the machine screws (key 17) and tighten in a crisscross pattern, using 5 to 7 ft-lbs / 7 to 9 N•m of torque.
9. Replace the closing cap gasket (key 19) and install the closing cap (key 12). When all maintenance is complete, refer to the Startup and Adjustment section to put the relief valve or backpressure regulator into operation and adjust the pressure setting.

Parts Ordering

Each Type 63EG or 1098-63EGR relief valve is assigned a serial number or FS number which can be found on the nameplates. Refer to this number when contacting your local Sales Office for assistance or when ordering replacement parts.

When ordering a replacement part, be sure to include the complete 11-character part number. Separate kits containing all recommended spare parts are available for both the main valve and pilot.

Note

In this parts list, parts marked NACE are intended for corrosion-resistant service as detailed in the NACE International Standard MR0175-2003 and MR0103.

Types 63EG and 1098-63EGR

Parts List

Main Valve (Figure 10 or 11)

Key	Description	Part Number	Key	Description	Part Number
	Main Valve Parts kit (included are keys 4, 7, 12, 14, 15, 17, 20 and 21)		1	Valve Body	
	Nitrile (NBR)			Type 63EG	
	NPS 1 / DN 25	R63EGX00112		Cast Iron	
	NPS 2 / DN 50	R63EGX00122		NPT 1	34B7611X012
	NPS 3 / DN 80	R63EGX00132		NPT 2	38A8845X012
	NPS 4 / DN 100	R63EGX00142		CL125 FF	
	NPS 6 / DN 150	R63EGX00162		NPS 1 / DN 25	34B8630X012
	Fluorocarbon (FKM)			NPS 2 / DN 50	38A8847X012
	NPS 1 / DN 25	R63EGXFK112		NPS 3 / DN 80	38A8851X012
	NPS 2 / DN 50	R63EGXFK122		NPS 4 / DN 100	38A8865X012
	NPS 3 / DN 80	R63EGXFK132		NPS 6 / DN 150	38A8875X012
	NPS 4 / DN 100	R63EGXFK142		NPT 1	37B5946X012
	NPS 6 / DN 150	R63EGXFK162		NPT 1 (NACE)	37B5946X022
	Parts kit, Quick Change Trim Assembly (included are keys 2, 11, 9, 16, 13 and Nitrile (NBR) elastomers)			NPT 2	38A8848X012
	Type 63EG with Steel Body Flange			NPT 2 (NACE)	38A8848X022
	10 to 40 psig / 0.69 to 2.76 bar,			CL150 RF	
	Spring color, Yellow			NPS 1 / DN 25	37B5947X012
	NPS 2 / DN 50	25A3169X352		NPS 1 / DN 25 (NACE)	37B5947X022
	NPS 3 / DN 80	25A3169X392		NPS 2 / DN 50	38A8853X012
	NPS 4 / DN 100	25A3169X432		NPS 2 / DN 50 (NACE)	38A8853X052
	NPS 6 / DN 150	25A3169X472		NPS 3 / DN 80	38A8872X012
	30 to 125 psig / 2.07 to 8.62 bar,			NPS 3 / DN 80 (NACE)	38A8872X062
	Spring color, Green			NPS 4 / DN 100	38A8867X012
	NPS 1 / DN 25	25A3170X422		NPS 4 / DN 100 (NACE)	38A8867X032
	NPS 2 / DN 50	25A3169X362		NPS 6 / DN 150	38A7115X012
	NPS 3 / DN 80	25A3169X402		NPS 6 / DN 150 (NACE)	38A7115X022
	NPS 4 / DN 100	25A3169X442		NPS 8 x 6 / DN 200 x 150	GE05973X012
	NPS 6 / DN 150	25A3169X482		NPS 8 x 6 / DN 200 x 150 (NACE)	GE05973X022
	85 to 400 psig / 5.86 to 27.6 bar,			CL300 RF	
	Spring color, Red			NPS 1 / DN 25	37B5948X012
	NPS 1 / DN 25	25A3170X442		NPS 1 / DN 25 (NACE)	37B5948X022
	NPS 2 / DN 50	25A3169X372		NPS 2 / DN 50	38A8849X012
	NPS 3 / DN 80	25A3169X412		NPS 2 / DN 50 (NACE)	38A8849X022
	NPS 4 / DN 100	25A3169X452		NPS 3 / DN 80	38A8871X012
	NPS 6 / DN 150	25A3169X492		NPS 3 / DN 80 (NACE)	38A8871X042
	Type 1098-63EGR			NPS 4 / DN 100	38A8869X012
	3 to 65 psig / 0.21 to 4.48 bar,			NPS 4 / DN 100 (NACE)	38A8869X022
	spring color, Green			NPS 6 / DN 150	38A8873X012
	Cast Iron Body Flange			NPS 6 / DN 150 (NACE)	38A8873X022
	NPS 2 / DN 50	25A3169X092		NPS 8 x 6 / DN 200 x 150	GE05974X012
	NPS 3 / DN 80	25A3169X152		NPS 8 x 6 / DN 200 x 150 (NACE)	GE05974X022
	NPS 4 / DN 100	25A3169X222		CL600 RF	
	NPS 6 / DN 150	25A3169X272		NPS 1 / DN 25	37B5949X012
	Steel Body Flange			NPS 1 / DN 25 (NACE)	37B5949X022
	NPS 2 / DN 50	25A3169X382		NPS 2 / DN 50	38A8844X012
	NPS 3 / DN 80	25A3169X422		NPS 2 / DN 50 (NACE)	38A8844X022
	NPS 4 / DN 100	25A3169X462		NPS 3 / DN 80	38A8852X012
	NPS 6 / DN 150	25A3169X502		NPS 3 / DN 80 (NACE)	38A8852X032
				NPS 4 / DN 100	38A8866X012
				NPS 4 / DN 100 (NACE)	38A8866X022
				NPS 6 / DN 150	38A8874X012
				NPS 6 / DN 150 (NACE)	38A8874X022
				NPS 8 x 6 / DN 200 x 150	GE05975X012
				NPS 8 x 6 / DN 200 x 150 (NACE)	GE05975X022
				PN 16/25/40	
				NPS 1 / DN 25	GE05956X012
				NPS 2 / DN 50	GE05960X012
				NPS 3 / DN 80	GE05965X012
				NPS 4 / DN 100	GE05969X012
				NPS 6 / DN 150	GE05972X012

- continued -

Types 63EG and 1098-63EGR

Key	Description	Part Number	Key	Description	Part Number
1	Valve Body (continued)		4*	Gasket, composition	
	WCB			NPS 1 / DN 25	14A6785X012
	PN 25, NPS 8 X 6 / DN 200 x 150	GE05977X012		NPS 1 / DN 25 for oxygen service	14A6785X052
	BWE, NPS 8 X 6 / DN 200 x 150	GE05976X012		NPS 2 / DN 50	14A5685X012
	CF8M Stainless Steel			NPS 2 / DN 50 for oxygen service	14A5685X072
	NPT 1	37B5946X032		NPS 3 / DN 80	14A5665X012
	NPT 2	38A8848X032		NPS 3 / DN 80 for oxygen service	14A5665X022
	CL150 RF			NPS 4 / DN 100	14A5650X012
	NPS 1 / DN 25	37B5947X032		NPS 4 / DN 100 for oxygen service	14A5650X062
	NPS 2 / DN 50	38A8853X072		NPS 6 / DN 150	14A6984X012
	NPS 3 / DN 80	38A8872X052		NPS 6 / DN 150 for oxygen service	14A6984X032
	NPS 4 / DN 100	38A8867X042			
	NPS 6 / DN 150	38A7115X032	5	Indicator Fitting, plated steel	
	CL300 RF			(use only with optional travel indicator)	
	NPS 1 / DN 25	37B5948X032		NPS 1 / DN 25	T21117T0012
	NPS 2 / DN 50	38A8849X032		NPS 1 / DN 25 (NACE)	T21117T0022
	NPS 3 / DN 80	38A8871X052		NPS 2, 3 and 4 / DN 50, 80 and 100	T21107T0012
	NPS 4 / DN 100	38A8869X032		NPS 2, 3 and 4 / DN 50, 80 and 100 (NACE)	T21107T0022
	NPS 6 / DN 150	38A8873X032		NPS 6 / DN 150	T21120T0012
	CL600 RF		6	O-ring Retainer (use only with	
	NPS 1 / DN 25	37B5949X032		optional travel indicator) 416 Stainless steel	T14276T0012
	NPS 2 / DN 50	38A8844X032	7*	Stem O-ring (use only with optional	
	NPS 3 / DN 80	38A8852X042		travel indicator)	
	NPS 4 / DN 100	38A8866X032		For NPS 1 / DN 25	
	NPS 6 / DN 150	38A8874X032		Nitrile (NBR)	1D687506992
	PN 16/25/40			Fluorocarbon (FKM)	1N430406382
	NPS 1 / DN 25	GE05956X022		For NPS 2, 3, 4 and 6 / DN 50, 80, 100 and 150	
	NPS 2 / DN 50	GE05960X022		Nitrile (NBR)	1E472706992
	NPS 3 / DN 80	GE05965X022		Fluorocarbon (FKM)	1N430406382
	NPS 4 / DN 100	GE05969X022		FFKM	
	NPS 6 / DN 150	GE05972X022		NPS 1, 2, 3, 4 and 6 /	
2	Body Flange			DN 25, 50, 80, 100 and 150	1D6875X0082
	Cast Iron, ENC			EPR	
	NPS 1 / DN 25	24A6779X012		NPS 1, 2, 3, 4 and 6 /	
	NPS 2 / DN 50	25A3168X012		DN 25, 50, 80, 100 and 150	1D6875X0092
	NPS 3 / DN 80	24A9034X012			
	NPS 4 / DN 100	25A2309X012	8	Hex Nut, plated steel (used only with optional	
	NPS 6 / DN 150	34A8172X012		travel indicator)	1A662228992
	WCC Steel, ENC, heat-treated (NACE)		9 ⁽¹⁾	Spring	
	NPS 1 / DN 25	24A6779X012		Type 63EG	
	NPS 2 / DN 50	25A2254X012		10 to 40 psig / 0.69 to 2.76 bar	
	NPS 3 / DN 80	25A2300X012		allowable set pressure, Yellow	
	NPS 4 / DN 100	24A9032X012		Zinc-plated steel	
	NPS 6 / DN 150	34A7152X012		NPS 2 / DN 50	14A6768X012
	316 Stainless steel (NACE)			NPS 3 / DN 80	14A6771X012
	NPS 1 / DN 25	24A6779X062		NPS 4 / DN 100	14A6770X012
	NPS 2 / DN 50	25A2254X082		NPS 6 / DN 150	15A2253X012
	NPS 3 / DN 80	25A2300X122		Inconel® X750 (NACE)	
	NPS 4 / DN 100	24A9032X042		NPS 2 / DN 50	16A5502X012
	NPS 6 / DN 150	34A7152X052		NPS 3 / DN 80	16A5505X012
3	Cap Screw, Zinc-plated steel (use with Cast iron			NPS 4 / DN 100	16A5507X012
	and steel bodies)			NPS 6 / DN 150	16A5509X012
	NPS 1 / DN 25, Cast iron and steel bodies			30 to 125 psig / 2.07 to 8.62 bar	
	(4 required)	1R281124052		allowable set pressure, Green	
	NPS 2 / DN 50 (8 required)	1A453324052		Zinc-plated steel	
	NPS 3 / DN 80 (8 required)	1A454124052		NPS 1 / DN 25	14A9687X012
	NPS 4 / DN 100 (8 required)	1A485724052		NPS 2 / DN 50	14A6626X012
	NPS 6 / DN 150 (12 required)	1U513124052		NPS 3 / DN 80	14A6629X012
3	Stud Bolt, steel (use with Stainless			NPS 4 / DN 100	14A6632X012
	steel body) (not shown)			NPS 6 / DN 150	14A9686X012
	NPS 1 / DN 25, Stainless steel bodies			Inconel X750 (NACE)	
	(4 required)	1R284835222		NPS 1 / DN 25	11B6769X012
	NPS 2 / DN 50 (8 required)	1K242935222		NPS 2 / DN 50	16A5501X012
	NPS 3 / DN 80 (8 required)	1A378135222		NPS 3 / DN 80	16A5503X012
	NPS 4 / DN 100 (8 required)	1R369035222		NPS 4 / DN 100	16A5506X012
	NPS 6 / DN 150 (12 required)	1A365635222		NPS 6 / DN 150	16A5510X012

- continued -

*Recommended spare part.
Inconel® is a mark owned by Special Metal Corporation.
1. Part included in trim package assembly.

Types 63EG and 1098-63EGR

Key	Description	Part Number	Key	Description	Part Number
9 ⁽¹⁾	Spring Type 63EG (continued) 85 to 400 psig / 5.86 to 27.6 bar allowable set pressure, Red Zinc-plated steel NPS 1 / DN 25 NPS 2 / DN 50 NPS 3 / DN 80 NPS 4 / DN 100 NPS 6 / DN 150 Inconel® X750 (NACE) NPS 1 / DN 25 NPS 2 / DN 50 NPS 3 / DN 80 NPS 4 / DN 100 NPS 6 / DN 150 Type 1098-63EGR (continued) 3 to 65 psig / 0.21 to 4.48 bar allowable set pressure, Green Zinc-plated steel NPS 1 / DN 25 NPS 2 / DN 50 NPS 3 / DN 80 NPS 4 / DN 100 NPS 6 / DN 150 Inconel X750 (NACE) NPS 1 / DN 25 NPS 2 / DN 50 NPS 3 / DN 80 NPS 4 / DN 100 NPS 6 / DN 150	14A9679X012 14A6628X012 14A6631X012 14A6634X012 15A2615X012 10B1882X012 16A5499X012 16A5500X012 16A5998X012 16A6000X012 14A9687X012 14A6626X012 14A6629X012 14A6632X012 14A9686X012 11B6769X012 16A5501X012 16A5503X012 16A5506X012 16A5510X012	11*	Cage (continued) Quick Opening, 316 Stainless steel NPS 1 / DN 25 NPS 2 / DN 50 NPS 3 / DN 80 NPS 4 / DN 100 NPS 6 / DN 1500 12* Port Seal Nitrile (NBR) (standard) NPS 1 / DN 25 NPS 2 / DN 50 NPS 3 / DN 80 NPS 4 / DN 100 NPS 6 / DN 150 Fluorocarbon (FKM) NPS 1 / DN 25 NPS 2 / DN 50 NPS 3 / DN 80 NPS 4 / DN 100 NPS 6 / DN 150 Perfluoroelastomer (FFKM) NPS 1 / DN 25 NPS 2 / DN 50 NPS 3 / DN 80 NPS 4 / DN 100 NPS 6 / DN 150 Ethylenepropylene (EPR) NPS 1 / DN 25 NPS 2 / DN 50 NPS 3 / DN 80 NPS 4 / DN 100 Nitrile (NBR) (UL® Approved) Type 63EGR NPS 4 / DN 100 NPS 6 / DN 150	GF03315X012 GF03319X012 GF03311X012 GF03314X012 37A7215X032 14A6788X012 24A5673X012 24A5658X012 24A5643X012 ERAA48517A0 14A8186X012 25A7412X012 25A7375X012 25A7469X012 14A6996X012 14A6788X042 24A5673X082 24A5658X052 24A5643X032 14A8175X042 14A6788X022 24A5673X062 24A5658X052 24A5643X052 24A5643X062 14A8175X022
10	Indicator Stem (used only with optional travel indicator) Stainless steel NPS 1 / DN 25 NPS 2 / DN 50 NPS 3 / DN 80 NPS 4 / DN 100 NPS 6 / DN 150 316 Stainless steel (NACE) NPS 1 / DN 25 NPS 2 / DN 50 NPS 3 / DN 80 NPS 4 / DN 100 NPS 6 / DN 150	T14311T0012 T14275T0012 T14312T0012 T14313T0012 T14314T0012 T14311T0022 T14275T0022 T14312T0022 T14313T0022 T14314T0022	13*	Seat Ring 416 Stainless steel ⁽¹⁾ NPS 1 / DN 25, 1-5/16 / 33.3 mm NPS 2 / DN 50, 2-3/8 / 60.3 mm NPS 3 / DN 80, 3-3/8 / 85.7 mm NPS 4 / DN 100, 4-3/8 / 111 mm NPS 6 / DN 150, 7-3/16 / 183 mm NPS 8 x 6 / DN 200 X 150 316 Stainless steel (NACE) NPS 1 / DN 25, 1-5/16 / 33.3 mm NPS 2 / DN 50, 2-3/8 / 60.3 mm NPS 3 / DN 80, 3-3/8 / 85.7 mm NPS 4 / DN 100, 4-3/8 / 111 mm NPS 6 / DN 150, 7-3/16 / 183 mm NPS 8 X 6 / DN 200 X 150	24A6781X012 24A5670X012 24A5655X012 24A5640X012 24A6989X012 38A4216X012 24A6781X022 24A5670X022 24A5655X022 24A5640X022 24A6989X022 38A4216X022
11*	Cage Linear ⁽¹⁾ CF8M Stainless steel NPS 1 / DN 25 NPS 2 / DN 50 NPS 3 / DN 80 NPS 4 / DN 100 NPS 6 / DN 150 Whisper Trim™ 416 Stainless steel NPS 1 / DN 25 NPS 2 / DN 50 NPS 3 / DN 80 NPS 4 / DN 100 NPS 6 / DN 150 316 Stainless steel (NACE) NPS 1 / DN 25 NPS 2 / DN 50 NPS 3 / DN 80 NPS 4 / DN 100 NPS 6 / DN 150	34B4136X012 34B5838X012 34B5839X012 34B5840X012 34B5841X012 24A2043X012 24A5707X012 24A5708X012 24A5709X012 24A8174X012 24A2043X022 24A5707X022 24A5708X042 24A5709X022 24A8174X022	14*	Piston Ring NPS 1 / DN 25 NPS 2 / DN 50, Polytetrafluoroethylene (PTFE) (Clear) NPS 3 / DN 80, PTFE (Clear) NPS 4 / DN 100, PTFE (Clear) NPS 6 / DN 150, glass-filled PTFE (Yellow)	14A6786X012 14A5675X012 14A5660X012 14A5645X012 14A6985X022
			15*	Upper Seal Nitrile (NBR) (standard) NPS 1 / DN 25 NPS 2 / DN 50 NPS 3 / DN 80 NPS 4 / DN 100 NPS 6 / DN 150	14A6789X012 24A5674X012 24A5659X012 24A5644X012 ERAA48518A0

- continued -

*Recommended spare part.
Inconel® is a mark owned by Special Metal Corporation.
UL® is a mark owned by Underwriters Laboratories.
1. Part included in trim package assembly.

Types 63EG and 1098-63EGR

Key	Description	Part Number	Key	Description	Part Number
15*	Upper Seal (continued)		18	Indicator Scale, plastic (used only with optional travel indicator)	
	Fluorocarbon (FKM)			NPS 1 / DN 25	14A6759X012
	NPS 1 / DN 25	14A8187X012		NPS 2 / DN 50	14A5678X012
	NPS 2 / DN 50	25A7413X012		NPS 3 / DN 80	14A5662X012
	NPS 3 / DN 80	25A7376X012		NPS 4 or 6 / DN 100 or 150	14A5647X012
	NPS 4 / DN 100	25A7468X012	19	Indicator Protector (used only with optional travel indicator), Zinc-plated steel	
	NPS 6 / DN 150	14A8185X012		NPS 1 and 2 / DN 25 and 50	24B1301X012
	Perfluoroelastomer (FFKM)			NPS 3, 4 or 6 / DN 80, 100 or 150	14A6769X012
	NPS 1 / DN 25	14A6789X042	20*	Flange O-ring	
	NPS 2 / DN 50	24A5674X082		Nitrile (NBR) (standard)	
	NPS 3 / DN 80	24A5659X052		NPS 1 / DN 25	14A6981X012
	NPS 4 / DN 100	24A5644X032		NPS 2 / DN 50	14A5686X012
	NPS 6 / DN 150	14A8176X042		NPS 3 / DN 80	1V326906562
	Ethylenepropylene (EPR)			NPS 4 / DN 100	14A5688X012
	NPS 1 / DN 25	14A6789X022		NPS 6 / DN 150	1K879306992
	NPS 2 / DN 50	24A5674X062		Fluorocarbon (FKM)	
	NPS 3 / DN 80	24A5659X062		NPS 1 / DN 25	14A8188X012
	NPS 4 / DN 100	24A5644X052		NPS 2 / DN 50	14A5686X022
	NPS 6 / DN 150	14A8176X022		NPS 3 / DN 80	1V3269X0042
16*	Valve Plug, heat-treated			NPS 4 / DN 100	14A5688X022
	416 Stainless steel ⁽¹⁾			NPS 6 / DN 150	1V547606382
	NPS 1 / DN 25	14A6780X012		Perfluoroelastomer (FFKM)	
	NPS 2 / DN 50	24A6772X012		NPS 1 / DN 25	14A6981X072
	NPS 3 / DN 80	24A9421X012		NPS 2 / DN 50	14A5686X072
	NPS 4 / DN 100	24A8182X012		NPS 3 / DN 80	1V3269X0082
	NPS 6 / DN 150	24A6992X012		NPS 4 / DN 100	14A5688X112
	316 Stainless steel (NACE)			NPS 6 / DN 150	1K8793X0022
	NPS 1 / DN 25 (for Type 63EG)	17B7565X022		Ethylenepropylene (EPR)	
	NPS 1 / DN 25 (for Type 1068-63EGR)	14A6780X022		NPS 1 / DN 25	14A6981X032
	NPS 2 / DN 50	24A6772X032		NPS 2 / DN 50	14A5686X052
	NPS 3 / DN 80	24A9421X022		NPS 3 / DN 80	1V3269X0062
	NPS 4 / DN 100	24A8182X022		NPS 4 / DN 100	14A5688X082
	NPS 6 / DN 150	24A6992X022		NPS 6 / DN 150	1K8793X0012
17*	Cage O-ring		21*	Flange O-ring	
	Nitrile (NBR) (standard)			Nitrile (NBR) (standard)	
	NPS 1 / DN 25	10A7777X012		NPS 1 / DN 25	10A8931X012
	NPS 2 / DN 50	10A7779X012		NPS 2, 3 and 4 / DN 50, 80 and 100	10A3800X012
	NPS 3 / DN 80	14A5688X012		NPS 6 / DN 150	1F262906992
	NPS 4 / DN 100	10A3481X012		Fluorocarbon (FKM)	
	NPS 6 / DN 150	18A2556X022		NPS 1 / DN 25	10A0811X012
	Fluorocarbon (FKM)			NPS 2, 3 and 4 / DN 50, 80 and 100	1R727606382
	NPS 1 / DN 25	10A7778X012		NPS 6 / DN 150	1F2629X0012
	NPS 2 / DN 50	10A7779X022		Perfluoroelastomer (FFKM)	
	NPS 3 / DN 80	14A5688X022		NPS 1 / DN 25	10A8931X032
	NPS 4 / DN 100	10A3483X012		NPS 2, 3 and 4 / DN 50, 80 and 100	10A3800X062
	NPS 6 / DN 150	18A2556X032		NPS 6 / DN 150	1F2629X0012
	Perfluoroelastomer (FFKM)			Ethylenepropylene (EPR)	
	NPS 1 / DN 25	10A7777X032		NPS 1 / DN 25	10A8931X022
	NPS 2 / DN 50	10A7779X132		NPS 2, 3 and 4 / DN 50, 80 and 100	10A3800X042
	NPS 3 / DN 80	14A5688X112		NPS 6 / DN 150	1F2629X0032
	NPS 4 / DN 100	10A3481X032	22	Flange Nut, plated steel (used only with optional travel indicator)	14A5693X012
	NPS 6 / DN 150	18A2556X062			
	Ethylenepropylene (EPR)				
	NPS 1 / DN 25	10A7777X022			
	NPS 2 / DN 50	10A7779X052			
	NPS 3 / DN 80	14A5688X082			
	NPS 4 / DN 100	10A3481X052			
	NPS 6 / DN 150	18A2556X072			

- continued -

*Recommended spare part.
1. Part included in trim package assembly.

Types 63EG and 1098-63EGR

Main Valve (Figure 10 or 11) (continued)

Key	Description	Part Number
23	E-ring (used only with optional travel indicator) Stainless steel	14A8181X012
	1577 steel, heat treated (NACE)	14A8181X022
24	Drive Screw, Stainless steel (4 required)	1A368228982
25	Flow Arrow, Stainless steel	-----
26	Nameplate	-----
27	Flange Plug (not used with optional travel indicator), Plated steel	
	NPS 1 / DN 25, Nitrile (NBR)	14A6983X012
	NPS 1 / DN 25, Nitrile (NBR) (NACE)	14A6983X022
	NPS 2, 3 or 4 / DN 50, 80 or 100	14A9684X012
	NPS 2, 3 or 4 / DN 50, 80 or 100 (NACE)	14A9684X032
	NPS 6 / DN 150 (NACE)	14A8178X032
28	Spring Seat (used only with optional travel indicator) Plated steel	
	NPS 1 / DN 25	14A6982X012
	NPS 2, 3 or 4 / DN 50, 80 or 100	15A2206X012
	NPS 6 / DN 150	14A8177X012
	Heat-treated plated steel (NACE)	
	NPS 1 / DN 25	14A6982X022
	NPS 2, 3 or 4 / DN 50, 80 or 100	15A2206X022
	NPS 6 / DN 150	14A8177X022
29	Hex Nut, steel (use with Stainless steel body) (not shown)	
	NPS 1 / DN 25 (4 required)	1C330635252
	NPS 2 / DN 50 (8 required)	1A377235252
	NPS 3 / DN 80 (8 required)	1A376035252
	NPS 4 / DN 100 (8 required)	1A352035252
	NPS 6 / DN 150 (12 required)	1A440935252
31	Pipe Plug	
	Type 63EG (4 required)	
	Carbon steel	1E823128982
	316 Stainless steel (NACE)	1E8231X0012
	416 Stainless steel	1J797328982
	Type 63EGR	
	Plated carbon steel	T13718T0012
	316 Stainless steel (NACE)	1A767535072
	416 Stainless steel	1A767524662
32	NACE Tag (not shown)	-----
33	Tag Wire (not shown) (NACE)	-----
42	Fitting	T21104T0012
43	Backup Ring (2 required) NPS 1 and 2 / DN 25 and 50	1K786806992
44	O-ring	
	Nitrile (NBR)	18B3438X012
	Fluorocarbon (FKM)	1N430306382
	Perfluoroelastomer (FFKM)	1N4303X0032
	Ethylenepropylene (EPR)	1N4303X0012
45	Pipe plug	1A398524182

Mounting Parts (Figure 12)

Key	Description	Part Number
22	Pipe Nipple	
	Zinc galvanized steel	
	NPS 1, 2, 3 or 4 / DN 25, 50, 80 or 100	1N584226232
	Stainless steel (NACE)	
	NPS 2, 3 or 4 / DN 50, 80 or 100	1N5842X0022
23	Pipe Nipple (used only with Type 63EG)	
	Zinc galvanized steel	1C488226232
	Stainless steel (NACE)	1C488238982
24	Pipe Tee (used only with Type 63EG)	
	316 Stainless steel	1B8606X0032
	316 Stainless steel (NACE)	1P506938982
25	Connector	
	(2 required with Type 63EG and 1 required with Type 1098-63EGR)	-----
27	Type Y602-12 Vent Assembly, Zinc with Stainless steel screen	27A5516X012
28	Pilot Supply Tubing, Stainless steel (specify main valve body size and type number)	0500213809W
29	Pipe Plug	
	Steel (NACE)	1A767524662
	Stainless steel (NACE)	1A767535072
30	Pipe Nipple, galvanized steel	
	For Type 1098-63EGR only (not shown)	1C488226232
	Stainless steel	1C488238982
31	Pipe Bushing (used only with Type 1098-63EGR)	
	Steel	1C379026232
	Stainless steel	1C3790X0012
32	Pipe Plug (uses only with Type 1098-63EGR)	
	Steel	1A369224492
	Stainless steel	1A369235072
33	Actuator Tubing (used only with Type 1098-63EGR—specify main valve body size and actuator size)	
	Stainless steel	0500213809W
35	Pipe Cross, Type 1098-63EGR, plated steel	1L3719X0012

Type 1098 Actuators (Figure 13)

Key	Description	Part Number
	Parts kit (included are keys 5, 6, 7, 56 and 57), size 40	R1098X00402
1	Lower Diaphragm Case	
	Steel	24A7155X012
	Steel (NACE)	24A7155X072
	Stainless steel	24A7155X052
2	Upper Diaphragm Case	
	Zinc-plated steel	24A5680X012
	Wrought steel (NACE)	24A5680X062
	Stainless steel (NACE)	24A5680X042
3	Bonnet	
	Steel	33B0301X012
	Stainless steel (NACE)	33B0301X052
4	Cap Screw (4 required)	
	Zinc-plated steel	1D529824052
	B8M Zinc-plated steel (NACE)	1D529838992

- continued -

Types 63EG and 1098-63EGR

Type 1098 Actuators (Figure 13) (continued)

Key	Description	Part Number
5*	Case O-ring Nitrile (NBR) Fluorocarbon (FKM) Ethylene Propylene (EPDM)	1F358106992 1F3581X0022 1F3581X0052
6*	Stem O-ring (2 required) Nitrile (NBR) Fluorocarbon (FKM) Ethylene Propylene (EPDM)	1C782206992 1K756106382 1C7822X0052
7*	Diaphragm Nitrile (NBR) Fluorocarbon (FKM) Ethylene Propylene (EPDM)	27B9744X012 27B9744X022 27B9744X032
8	Diaphragm Plate Cast iron Heat-treated WCC steel (NACE)	14A5682X012 GE08466X012
9	Stem Cap Screw Plated steel Stainless steel (NACE)	1L545428982 1L545438992
10	Cap Screw, Zinc-plated steel (16 required) Steel Stainless steel	1E760324052 1E7603X0072
11	Hex Nut, Zinc-plated steel (16 required) Steel Stainless steel	1A346524122 1A3465X0032
12	Stem 17-4PH Stainless steel NPS 1 / DN 25 main valve body NPS 2 / DN 50 main valve body NPS 3 / DN 80 main valve body NPS 4 / DN 100 main valve body 17-4PH Stainless steel NPS 6 / DN 150 main valve body NPS 8 x 6 / DN 200 x 150 main valve body 316 Stainless steel (NACE) NPS 1 / DN 25 main valve body NPS 2 / DN 50 main valve body NPS 3 / DN 80 main valve body NPS 4 / DN 100 main valve body NPS 6 / DN 150 main valve body NPS 8 x 6 / DN 200 x 150 main valve body NPS 12 x 6 / DN 300 x 150 main valve body	14A6757X012 14A5683X012 14A5663X012 14A5648X012 14A6987X012 18A4217X022 14A6757X022 14A5683X022 14A5663X022 14A5648X022 14A6987X022 18A4217X022 17B6060X012
13	Nameplate, Stainless steel	-----
27	Type Y602-12 Vent Assembly	27A5516X012
28	Grease Zerk Fitting, steel	1A3465X0032
54	NACE Tag, 18-8 Stainless steel (not shown)	-----
55	NACE Tag Wire, 303 Stainless steel (not shown)	-----
56	Bearing, Nylon (PA) (2 required) For Nitrile (NBR) Diaphragm For Fluorocarbon (FKM)/ Ethylene Propylene (EPDM) Diaphragm	17A7112X012 17A7112X022
57	Wiper Ring	15A6002XN12

6358 Series Pilot (Figures 14 and 15)

Key	Description	Part Number
	Parts Kit (included are keys 4, 5, 13, 14, 19, 36, 37 and P590 Series Filter, keys 2 and 7)	
	Type 6358 parts kit	R6358X00012
	Type 6358B	R6358X00032
	Type 6358EB (75 to 200 psig / 5.17 to 13.8 bar)	R6358X00052
	Type 6358EB (180 to 350 psig / 12.4 to 24.1 bar)	R6358X00062
	Type 6358EBH	R6358X00072
1	Body Aluminum (NACE) (only available for Types 6358 and 6358B) Stainless steel (NACE)	39A0138X012 39A5972X012
2	Spring Case Types 6358 and 6358B Aluminum Stainless steel	25A6220X012 28A9277X012
	Types 6358EB and 6358EBH Stainless steel	27B9722X012
3	Body Plug Aluminum (NACE) Stainless steel Stainless steel (NACE)	1B797509032 1B7975X0052 1B797535072
4*	Valve Plug Assembly, Stainless steel plug with Types 6358 and 6358B Nitrile (NBR) plug Fluorocarbon (FKM) plug Types 6358EB and 6358EBH Nitrile (NBR) plug Fluorocarbon (FKM) plug	14B6372X012 16A2924X012 18B3427X012 18B3427X022
5*	Diaphragm Assembly Types 6358 and 6358B Nitrile (NBR) Nitrile (NBR) (NACE) Fluorocarbon (FKM) Type 6358EB Nitrile (NBR) 75 to 200 psig / 5.17 to 13.8 bar 180 to 350 psig / 12.4 to 24.1 bar Fluorocarbon (FKM) 75 to 200 psig / 5.17 to 13.8 bar 180 to 350 psig / 12.4 to 24.1 bar Type 6358EBH Nitrile (NBR) Fluorocarbon (FKM)	15A6216X072 15A6216X212 15A6216X172 18B3428X012 18B3428X022 18B3428X042 18B3428X052 18B3429X012 18B3429X022
6	Connector Cap, Stainless steel Types 6358 and 6358B Standard NACE Type 6358EB or 6358EBH Standard NACE	16A2921X012 16A2921X022 14B9813X012 14B9813X022

- continued -

*Recommended spare part.

Types 63EG and 1098-63EGR

Key	Description	Part Number	Key	Description	Part Number
7	Control Spring Type 6358 10 to 40 psig / 0.69 to 2.76 bar, Yellow 35 to 125 psig / 2.41 to 8.62 bar, Red Type 6358B 10 to 30 psig / 0.69 to 2.07 bar, Silver 30 to 60 psig / 2.07 to 4.14 bar, Blue 60 to 125 psig / 4.14 to 8.62 bar, Red Type 6358EB 85 to 140 psig / 5.86 to 9.65 bar, Green 130 to 200 psig / 8.96 to 13.8 bar, Blue 180 to 350 psig / 12.4 to 24.1 bar, Red Type 6358EBH 250 to 400 psig / 17.2 to 27.6 bar, Blue	1E392527022 1K748527202 1B788327022 1B788427022 1K748527202 17B1261X012 17B1263X012 17B1264X012 17B1263X012	15	O-ring (for Type 6358EB only)	10A7777X012
8	Spring Seat, Zinc-plated steel Types 6358 and 6358B Type 6358EB or 6358EBH	1B798525062 17B0515X012	16	Vent Assembly, Type Y602X1-A12 (2 required)	27A5515X012
9	Stem Guide Stainless steel Stainless steel (NACE)	16A2923X012 16A2923X022	17	Machine Screw (6 required) Type 6358EB Aluminum Stainless Steel Type 6358EBH	1V4360X0022 1V4360X0112 T12980T0012
10	Adjusting Screw Types 6358 and 6358B Type 6358EB 75 to 140 psig / 5.17 to 9.65 bar 130 to 200 psig / 8.96 to 13.8 bar 180 to 350 psig / 12.4 to 24.1 bar Type 6358EBH	10B7192X012 17B1227X012 10B3081X012 10B3080X012 10B3080X012	18	Connector Cap O-ring (for Types 6358EB and 6358EBH) Nitrile (NBR) Fluorocarbon (FKM)	10A0904X012 10A0904X032
11	Locknut Types 6358 and 6358B Type 6358EB or 6358EBH	1A946324122 1D667728982	19*	Closing Cap Gasket (for use with Stainless steel Types 6358 and 6358B)	15A6218X012
12	Closing Cap Types 6358 and 6358B Aluminum Aluminum (NACE) Stainless steel (NACE) Types 6358EB and 6358EBH Stainless steel (NACE)	23B9152X012 1H2369X0012 1H2369X0032 24B1301X012	20	Restriction Plug (for Type 6358 only) Standard NACE	1A346128982 1V7435X0012
13*	Body Plug O-ring, Nitrile (NBR) (for use with Stainless steel bodies) Nitrile (NBR) Fluorocarbon (FKM)	1F113906992 1N463906382	20	Restriction Type 6358B High Gain Medium Gain Low Gain Types 6358EB and 6358EBH High Gain Standard Low Gain Standard	17A7279X012 17A2029X012 17A7277X012 17A7279X012 17A2030X012
13*	Body Plug Gasket (for use with aluminum bodies on Types 6358 and 6358B only)	1C495704022	36*	Connector Cap O-ring or Gasket (2 required) Fluorocarbon (FKM)	1U1716X0012
14	Valve Plug Spring Types 6358, 6358EB and 6358EBH Standard Stainless steel (NACE) Type 6358B Stainless steel Stainless steel (NACE)	1E701337022 19A8179X012 17A2328X012 19A8179X012	37	Stem O-ring Nitrile (NBR) Fluorocarbon (FKM)	16A2920X012 16A2920X022
			38	Lower Spring Seat, thermoplastic Types 6358EB and 6358EBH	18B1248X012
			40	Diaphragm Limiter for Type 6358EB at 180 to 350 psig / 12.4 to 24.1 bar	10B4407X012
			42	NACE Tag	-----
			43	Tag Wire	-----

*Recommended spare part.

Types 63EG and 1098-63EGR

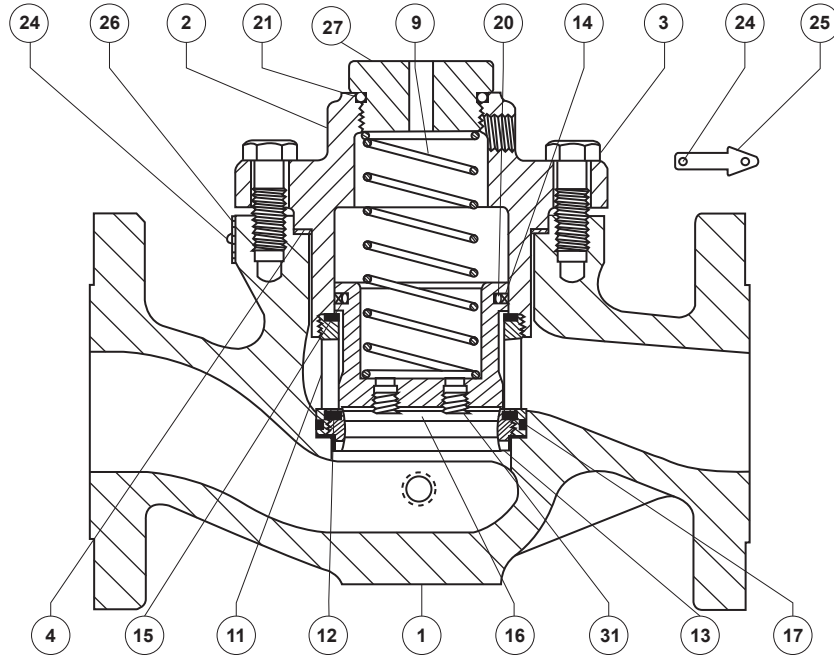

35A3174-A

COMPLETE CAST IRON MAIN VALVE ASSEMBLY

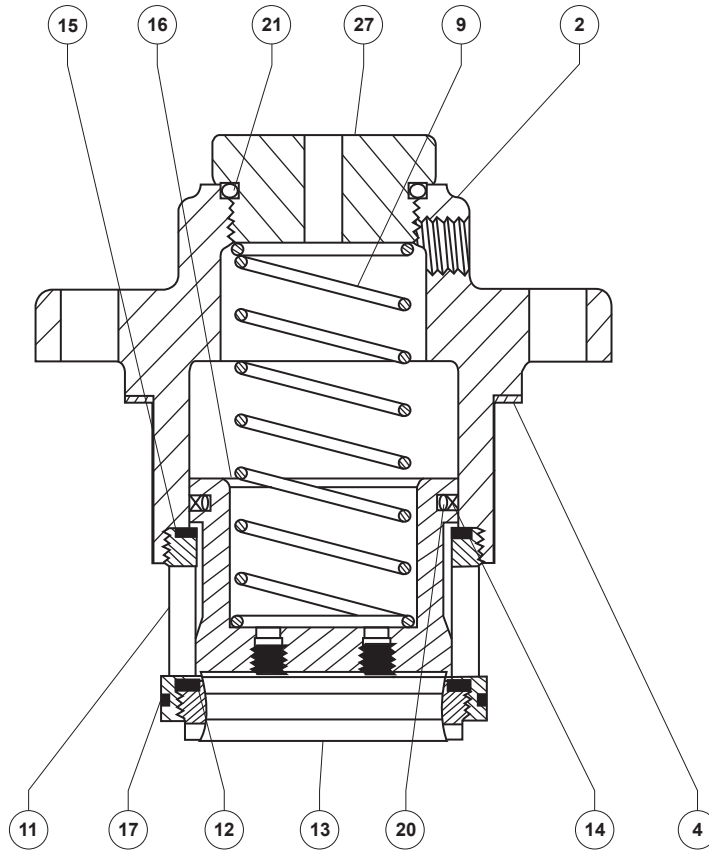

25A3169_B

QUICK-CHANGE TRIM PACKAGE ASSEMBLY

Figure 10. Type 63EG Main Valve without Travel Indicator Assembly

Types 63EG and 1098-63EGR

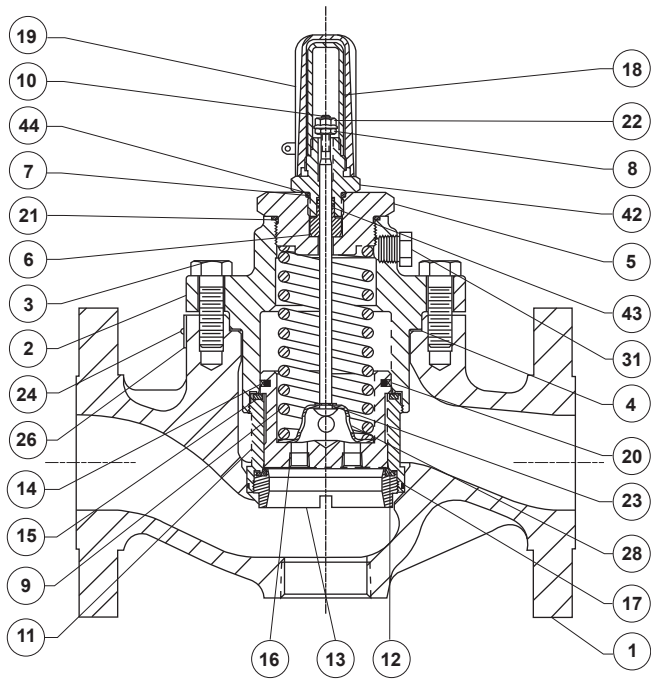

35A3167-E

COMPLETE CAST IRON MAIN VALVE ASSEMBLY

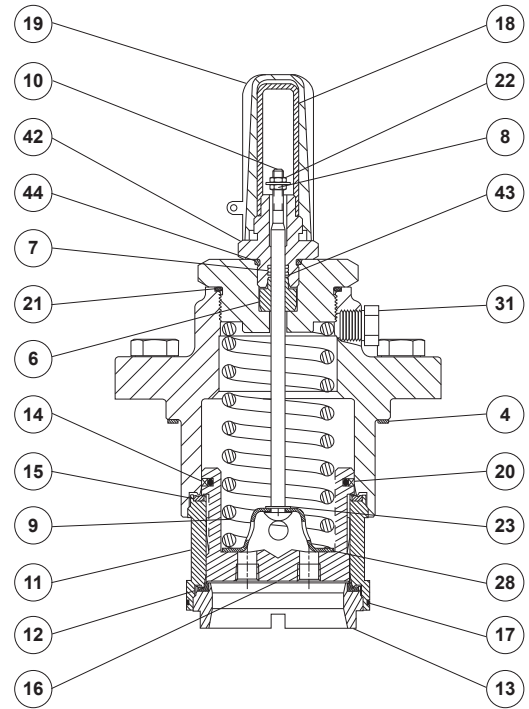

25A3170

QUICK-CHANGE TRIM PACKAGE ASSEMBLY

Figure 11. Type 63EGR Main Valve with Travel Indicator Assembly

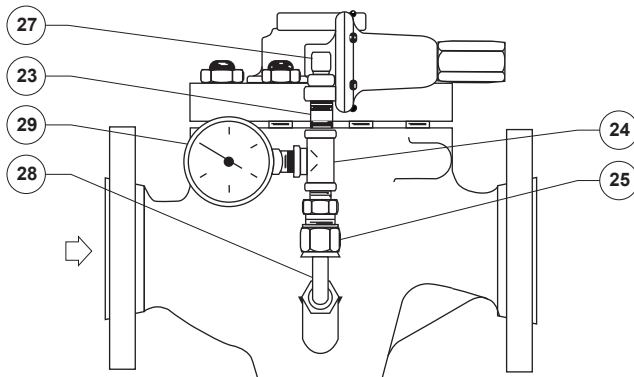

25A3178_B

TYPE 63EG MOUNTING PARTS

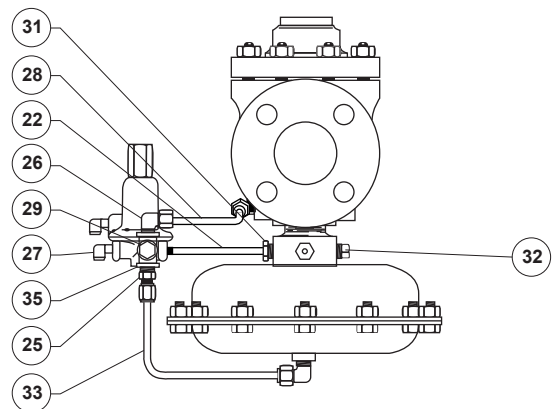

35A3179-C

TYPE 1098-63EGR MOUNTING PARTS

Figure 12. Mounting Parts Assembly

Types 63EG and 1098-63EGR

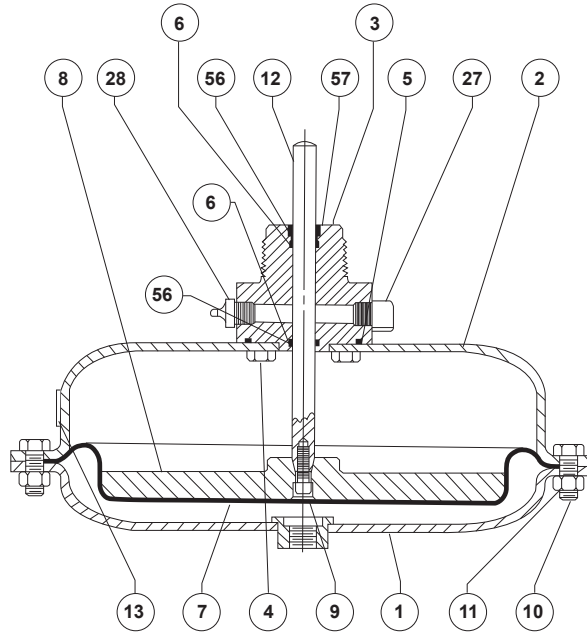

34A5692

Figure 13. Type 1098 Actuator Assembly

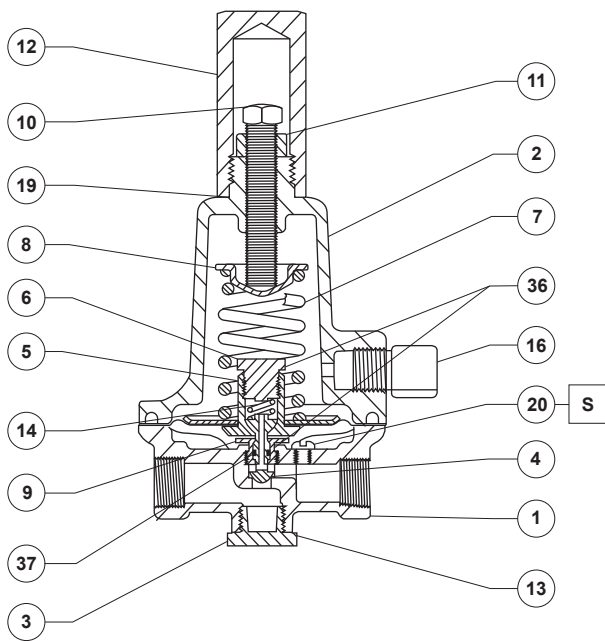

A6920_6365

TYPE 6358 PILOT INTERIOR VIEW

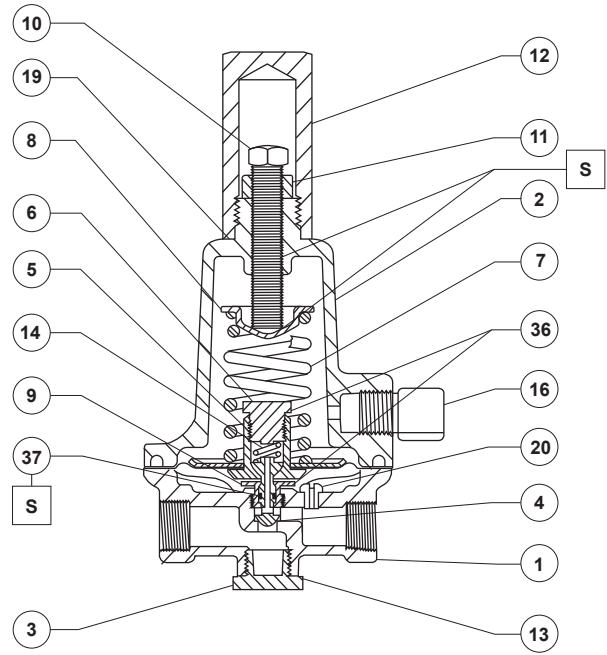

B2619-2_6365

TYPE 6358B PILOT INTERIOR VIEW

□ APPLY SEALANT (S)

Figure 14. Types 6358 and 6358B Pilots Assemblies

Types 63EG and 1098-63EGR

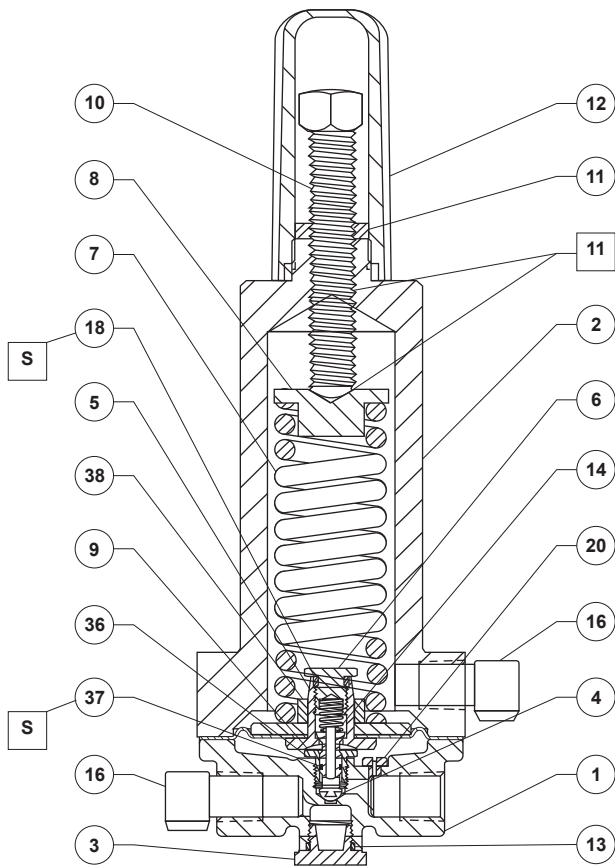

48B4649_A

TYPE 6358EB PILOT INTERIOR VIEW

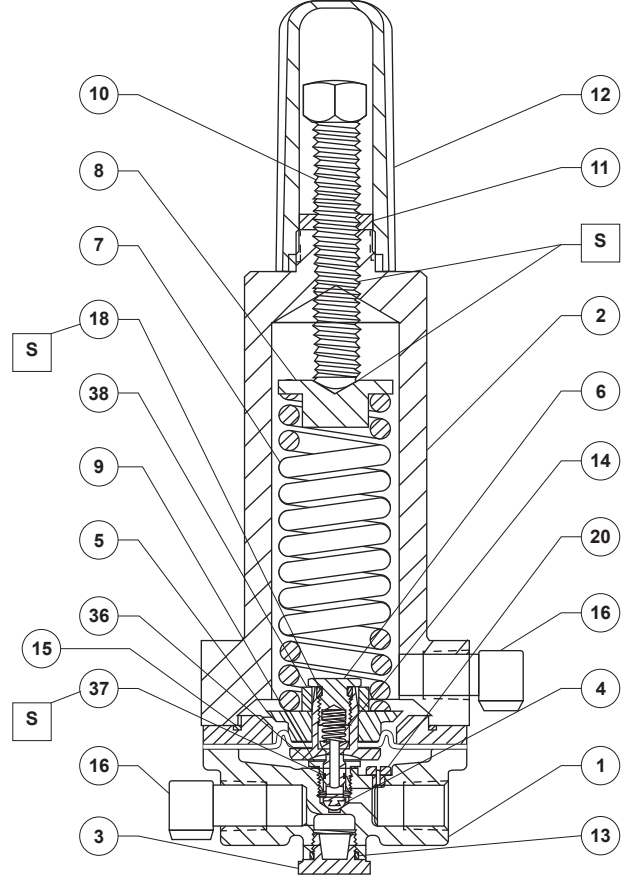

48B3431_A

TYPE 6358EBH PILOT INTERIOR VIEW

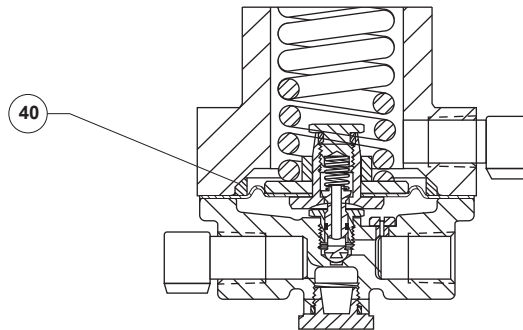

48B3430_A

**TYPE 6358EB PILOT WITH DIAPHRAGM LIMITER
FOR 180 TO 350 PSIG / 12.4 TO 24.1 BAR
SET PRESSURE RANGE INTERIOR VIEW**

APPLY SEALANT (S)

Figure 15. Types 6358EB and 6358EBH Pilots Assemblies

Types 63EG and 1098-63EGR

 Webadmin.Regulators@emerson.com

 [Fisher.com](https://www.fisher.com)

 [Facebook.com/EmersonAutomationSolutions](https://www.facebook.com/EmersonAutomationSolutions)

 [LinkedIn.com/company/emerson-automation-solutions](https://www.linkedin.com/company/emerson-automation-solutions)

 [X.com/EMR_automation](https://www.x.com/EMR_automation)

Emerson

Americas

McKinney, Texas 75069 USA
T +1 800 558 5853
+1 972 548 3574

Europe

Bologna 40013, Italy
T +39 051 419 0611

Asia Pacific

Singapore 128461, Singapore
T +65 6777 8211

Middle East and Africa

Dubai, United Arab Emirates
T +971 4 811 8100

D100315X012 © 1978, 2024 Emerson Process Management Regulator Technologies, Inc. All rights reserved. 1024.

Fisher™ is a mark owned by Fisher Controls International LLC, an Emerson Company. The Emerson logo is a trademark and service mark of Emerson Electric Co. All other marks are property of their respective owners.

The contents of this publication are presented for information purposes only, and while effort has been made to ensure their accuracy, they are not to be construed as warranties or guarantees, express or implied, regarding the products or services described herein or their use or applicability. All sales are governed by our terms and conditions, which are available on request. We reserve the right to modify or improve the designs or specifications of our products at any time without notice.

Emerson Process Management Regulator Technologies, Inc. does not assume responsibility for the selection, use or maintenance of any product. Responsibility for proper selection, use and maintenance of any Emerson Process Management Regulator Technologies, Inc. product remains solely with the purchaser.

