

January 2025

# 627B Series Pressure Reducing Regulators



## WARNING

Failure to follow these instructions or to properly install and maintain this equipment could result in an explosion and/or fire causing property damage and personal injury or death.

Fisher™ regulators must be installed, operated and maintained in accordance with federal, state and local codes, rules and regulations, and Emerson Process Management Regulator Technologies, Inc. instructions.

If the regulator vents gas or a leak develops in the system, service to the unit may be required. Failure to correct trouble could result in a hazardous condition.

Call a gas service person to service the unit. Only a qualified person must install or service the regulator.



W4793

Figure 1. Typical 627B Direct-Operated Pressure Reducing Regulator

## Introduction

### Scope of the Manual

This manual provides instructions for the installation, adjustment, maintenance and parts ordering information for the 627B Series Regulators. These regulators are usually shipped separately for line installation, although sometimes they are shipped installed on other equipment. Refer to the Instruction Manual of the other equipment for installation and operating instructions.

### Description

The 627B Series Direct-Operated Pressure Reducing Regulators (Figure 1) are for high and low pressure systems. These regulators can be used with natural gas, air or a variety of other gases. Performance characteristics vary according to construction.



## WARNING

Personal injury, property damage, equipment damage or leakage due to escaping gas or bursting of pressure-containing parts may result if this regulator is overpressured or is installed where service conditions could exceed the limits given in the Specifications section, Tables 1 and 2 or where conditions exceed any ratings of the adjacent piping or piping connections.

To avoid such injury or damage, provide pressure-relieving or pressure-limiting devices (as required by the appropriate code, regulation or standard) to prevent service conditions from exceeding those limits.

Additionally, physical damage to the regulator could cause personal injury or property damage due to escaping gas. To avoid such injury or damage, install the regulator in a safe location.

# 627B Series

## Specifications

The Specifications section gives some general specifications for the 627B Series Regulators. The nameplates give detailed information for a particular regulator as it comes from the factory.

### Available Constructions

**Type 627BM:** Direct-operated, balanced port pressure reducing regulator with a stem seal between the body outlet pressure and diaphragm case. Pressure is measured under the diaphragm through the 1/4 NPT downstream control line connection. (Figure 6)

**Type 627BMR:** Type 627BM with token internal relief. (Figure 7)

**Type 627BHM:** Type 627BM with a diaphragm limiter to deliver a higher outlet pressure. (Figure 8)

### Body Sizes and End Connection Styles

BODY SIZE		END CONNECTION STYLE	CONSTRUCTION AVAILABLE
NPS	DN		
1	25	NPT, CL150 RF, CL300 RF and CL600 RF	All
2	50	NPT, CL150 RF, CL300 RF and CL600 RF	

### Maximum Inlet Pressure<sup>(1)</sup> (Body Rating)

**Flanged Stainless steel:** 1440 psig / 99.3 barg

**NPT Stainless steel:** 2000 psig / 138 barg

**Flanged steel:** 1500 psig / 103 barg

**NPT steel:** 2000 psig / 138 barg

**Ductile iron:** 1000 psig / 69.0 barg

### Maximum Valve Disk Inlet Pressure Rating<sup>(1)</sup>

TYPE	DISK	INLET PRESSURE RATING		FCI CLASS
		psig	barg	
627B	Nitrile (NBR)	1000	69	VIII
	Nylon (PA)	1500	103	IV

### Maximum Operating Inlet Pressure, Pressure Differential and Outlet Pressure Ranges<sup>(1)</sup>

See Table 1 for pressures by orifice size and spring range

### Maximum Spring and Diaphragm Casing Pressure<sup>(1)</sup>

See Table 2

### Maximum Body Outlet Pressure<sup>(1)</sup>

**Types 627BM, 627BMR and 627BHM only**

*NPT steel:* 2000 psig / 138 barg

*Flanged steel:* 1500 psig / 103 barg

*Ductile iron:* 1000 psig / 69.0 barg

### Orifice Size

9/16 in. / 14.3 mm

### Options

- Up to 25% Hydrogen Blend (By Volume) Construction
- 100% Hydrogen Construction

### Internal Relief Performance

**Type 627BMR:** Limited by field-installed control line piping

### Elastomer Temperature Capabilities<sup>(1)(2)</sup>

MATERIAL	DISK/ DIAPHRAGM	TEMPERATURE	
		°F	°C
Nitrile (NBR)	Diaphragm	-40 to 180	-40 to 82
	O-ring		
	Disk		
Fluorocarbon (FKM)	Diaphragm	0 to 180	-18 to 82
Nylon (PA)	Disk	-40 to 180	-40 to 82
Neoprene (CR) for Type 627BHM only	Diaphragm	-40 to 180	-40 to 82

### Flow Coefficients

See Table 3

### Pressure Registration

**Type 627BM, 627BMR or 627BHM:** External through 1/4 NPT control line connection in the diaphragm casing

### Relief Indicator

For Type 627BMR (see Figure 7)

### Spring Case Vent Connection

3/4 NPT with removable screened vent assembly

### Approximate Weights

**627B Series**

*Ductile iron, Steel or Stainless steel Casings:*

10 lbs / 5 kg

*Aluminum Casing:* 6.3 lbs / 3 kg

1. The pressure/temperature limits in this Instruction Manual or any applicable standard limitation should not be exceeded.  
2. Stainless steel body is rated to -40°F / -40°C. Steel and Ductile iron bodies are rated to -20°F / -29°C.

## Product Description

**Type 627B Direct-Operated Pressure Reducing Regulator**—The Type 627B Regulator provides economical pressure reducing control for a variety of residential, commercial and industrial applications. The regulator pitot tube located in a high velocity stream provides dynamic boost that compensates for outlet pressure drop.

**Downstream Control Line for Type 627BM, 627BMR or 627BHM Regulator**—A Type 627BM, 627BMR or 627BHM Regulator has a blocking throat stem seal with O-rings and a 1/4 NPT control line connection in the diaphragm case. A regulator with a downstream control line is used for monitoring applications or other applications where other equipment is installed between the regulator and the pressure control point. The stem seal separates the body outlet pressure from the diaphragm case.

## Principle of Operation

Refer to Figure 2. When downstream demand decreases, the pressure under the diaphragm increases. This pressure overcomes the regulator setting (which is set by a spring). Through the action of the pusher post assembly, lever and valve stem, the valve disk moves closer to the orifice and reduces gas flow. If demand downstream increases, pressure under the diaphragm decreases. Spring force pushes the pusher post assembly downward and the valve disk moves away from the orifice.

## Installation

Regulator operation within ratings does not preclude the possibility of damage from debris in the lines or from external sources. A regulator should be inspected for damage periodically and after any overpressure condition. Key numbers referenced in this section are shown in Figures 6 through 8. Ensure that the operating temperature capabilities listed in Specifications section are not exceeded.

### Note

**If the regulator is shipped mounted on another unit, install that unit according to the appropriate Instruction Manual.**

Perform steps 1 through 6 for all types of regulators:

1. Only personnel qualified through training and experience should install, operate or maintain this regulator.
2. For a regulator that is shipped separately, make sure that there is no damage to or foreign material in the regulator.
3. Ensure that all tubing and piping have been blown free of foreign debris.
4. The regulator may be installed in any position as long as the flow through the body is in the direction indicated by the arrow cast on the body.
5. If continuous operation is required during inspection or maintenance, install a three-valve bypass around the regulator.



## WARNING

**A regulator may vent some gas to the atmosphere. In hazardous or flammable gas service, vented gas may accumulate and cause personal injury, death or property damage due to fire or explosion. Vent a regulator in hazardous gas service to a remote, safe location away from air intakes or any hazardous area. The vent line or stack opening must be protected against condensation or clogging.**

6. Position the body (key 1) and/or diaphragm spring case (key 29) so it will not collect moisture or debris into the screened vent. If the regulator requires repositioning, refer to the Body Area Maintenance Procedures and/or the Diaphragm and Spring Case Area Maintenance.

Procedures in the Maintenance section to reposition the screened vent for the application.

Perform steps 7 through 9 for Types 627BM, 627BMR and 627BHM Regulators only:

7. A Type 627BM or 627BMR Regulator requires a downstream control line. Install the control line before putting the regulator into operation.
8. Ensure that the downstream control line piping is at least 3/8 in. / 9.5 mm or larger outside diameter tubing and connected to a straight section of outlet piping 10 diameters downstream of the regulator.
9. A hand valve should be installed in the control line. This hand valve can be used to throttle down and dampen outlet pulsations in control pressure which may cause instability or cycling of the regulator.

## Remote Vent Line Installation

All 627B Series Regulators have a vent assembly installed in the 3/4 NPT spring case vent opening. The vent assembly can be removed to install a remote vent line if necessary. Remote vent lines must have the largest practical diameter. It should be as short as possible with minimum number of bends or elbows.

Protect the remote vent opening against entrance of rain, snow or any other foreign material that may plug the vent or vent line and prevent proper operation of the regulator. Periodically check the vent opening to be sure it is not plugged with foreign debris.

## Overpressure Protection

The 627B Series Regulators have outlet pressure ratings that are lower than their inlet pressure ratings. A pressure-relieving or pressure-limiting device must be provided by the user for the Types 627BM and 627BHM Regulators if the inlet pressure can exceed the outlet pressure rating, since these regulators do not have internal relief.

Type 627BMR Regulator provides overpressure relief via a small capacity or token relief that relieves minor overpressure caused by thermal expansion or minor nicks in the orifice or disk. Capacity of the token relief is limited by field-installed control line piping.

# 627B Series

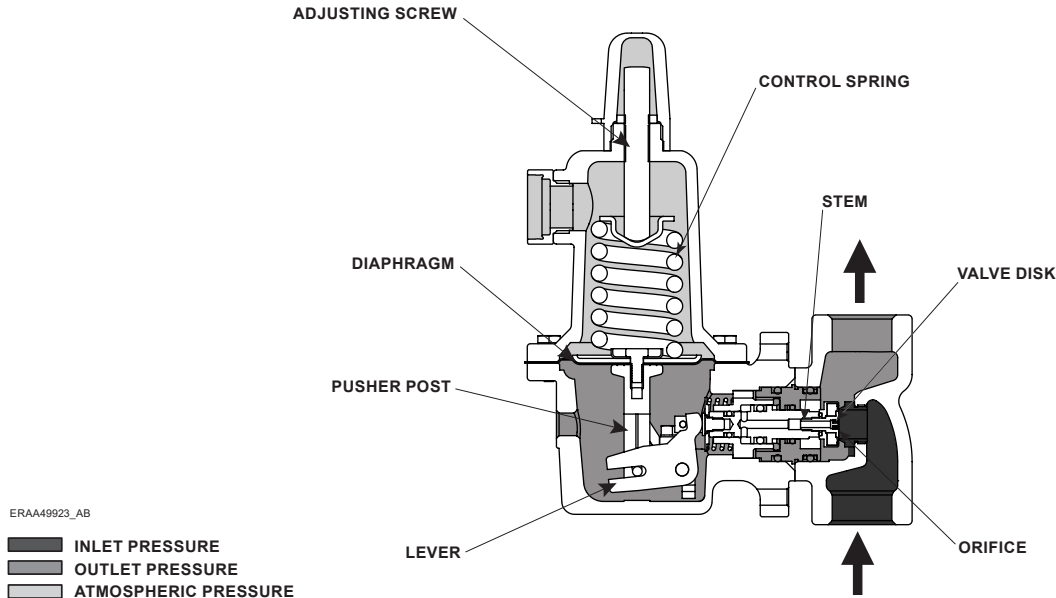

Figure 2. Type 627BM Operational Schematic

Table 1. Maximum Inlet Pressures and Outlet Pressure Ranges

TYPE	OUTLET PRESSURE RANGE		SPRING PART NUMBER	COLOR CODE	ORIFICE SIZE		MAXIMUM INLET PRESSURE <sup>(1)</sup>			
	psig	barg			in.	mm	Nylon (PA) Disk		Nitrile (NBR) Disk	
							psig	barg	psig	barg
627BM and 627BMR	5 <sup>(2)</sup> to 20	0.34 to 1.4	10B3076X012	Yellow	9/16 <sup>(3)</sup>	14.3	1500	103	1000	69
	15 to 40	1.0 to 2.8	10B3077X012	Green						
	35 to 80	2.4 to 5.5	10B3078X012	Blue						
	70 to 150	4.8 to 10.3	10B3079X012	Red						
627BHM	140 to 250	9.7 to 17.2	10B3078X012	Blue						
	240 to 500	16.5 to 34.5	10B3079X012	Red						

1. For inlet pressure in excess of 1000 psig / 69.0 barg, refer to the maximum body and disk pressure ratings in the Specifications section.  
 2. For pressure settings under 10 psig / 0.69 barg, inlet pressure should be limited to approximately 100 psig / 6.9 barg so the setpoint adjustment can be obtained.  
 3. Only available with 9/16 in. / 14.3 mm. orifice. If a smaller orifice is installed the unit will not achieve published capacities.

Table 2. Maximum Spring and Diaphragm Casing Pressure<sup>(1)</sup>

MAXIMUM PRESSURE DESCRIPTION	DIAPHRAGM CASING MATERIAL	TYPE 627BM		TYPE 627BMR		TYPE 627BHM	
		psig	barg	psig	barg	psig	barg
Maximum pressure to spring and diaphragm casings to prevent leak to atmosphere other than relief action (internal parts damage may occur)	Ductile iron	250	17.2	Not Available		Not Available	
	Steel or Stainless steel			250	17.2	800	55.2
Maximum pressure to spring and diaphragm casings to prevent burst of casings during abnormal operation (leak to atmosphere and internal parts damage may occur)	Ductile iron	465	32.1	465	32.1	Not Available	
	Steel or Stainless steel	1500	103	1500	103	1500	103
Maximum diaphragm casing overpressure (above setpoint) to prevent damage to internal parts	All materials	60	4.1	120	8.3	120	8.3

1. If the spring case is pressurized, a metal adjusting screw cap is required. Contact your local Sales Office for details.

**Table 3. Flow Coefficients**

ORIFICE		NPS 1 / DN 25 BODY			NPS 2 / DN 50 BODY		
In.	mm	Wide-Open $C_v$ for External Relief Sizing	Wide-Open $C_v$ for External Relief Sizing	$C_1$	Wide-Open $C_v$ for External Relief Sizing	Wide-Open $C_v$ for External Relief Sizing	$C_1$
9/16	14.3	211.6	5.6	37.8	219.3	6.0	36.0

**Table 4. Maximum Torque Values**

KEY NUMBER <sup>(1)</sup>	COMPONENT	CONSTRUCTION	MAXIMUM TORQUE		FASTNER TYPE	SIZE
			ft-lbs	N•m		
2	Orifice	All	25 to 35	33.9 to 47.5	7/8 in. Hex	1-5/16 in.
3	Cap screw, Body	Aluminum lower casing	10 to 20	13.6 to 27.1	3/8 in. Hex	9/16 in.
		Ductile iron or Steel lower casing	22 to 30	29.8 to 40.7	3/8 in. Allen Socket	3/8 in. Allen
9	Disk holder assembly	All	20 to 24 in-lbs	2.3 to 2.7	4 mm Allen	4 mm Allen
18	Cap screw, Lever	All	7 to 10	9.5 to 13.6	1/4 in. Hex	7/16 in.
22	Nut, Diaphragm Connector	627BMR	15 to 20	20.3 to 27.1	1.38 in. Hex	2 in.
26	Guide Retainer	627BMR	2.5 to 4	3.4 to 5.4	1/2 in. Hex	3/4 in.
37	Cap screw, Spring case	Ductile iron or Aluminum lower casing	7 to 10	9.5 to 13.6	1/4 in. Hex	7/16 in.
		Steel lower casing	36 to 40	48.8 to 54.2	3/8 in. Hex	9/16 in.
46	Cap screw, Diaphragm head	627BM	7 to 10	9.5 to 13.6	1/4 in. Hex	7/16 in.
		627BHM	12 to 16	16.3 to 21.7	5/16 in. Hex	1/2 in.
78	Spring seat retainer	All	55 to 60 in-lbs	6.2 to 6.8	N/A	N/A

1. Refer to Figures 6 through 8 for key number locations.

## Startup and Adjustment

### Startup



### WARNING

**To avoid personal injury or property damage due to explosion or damage to regulator or downstream components during startup, release downstream pressure to prevent an overpressure condition on the diaphragm of the regulator.**

**In order to avoid an overpressure condition and possible equipment damage, pressure gauges should always be used to monitor pressures during startup.**

1. Slowly open the upstream shut-off valve.
2. Slowly open the downstream shut-off valve.
3. Check all connections for leaks.
4. Make final control spring adjustments according to the adjustment procedures.

### Adjustment

The range of allowable pressure settings is marked on the nameplate. If a pressure setting beyond this range is necessary, substitute the appropriate regulator control spring. Change the nameplate to indicate the new pressure range.

Before increasing the setting, refer to Table 1 or 2. Review the pressure limits for the control spring range being used and be certain that the new pressure setting will not result in an overpressure condition.

#### Note

**Always use a pressure gauge to monitor pressure when making adjustments.**

Refer to Figures 6 through 8 for key number locations.

1. Remove the adjusting screw cap (key 36).
2. Loosen the locknut (key 34).
3. Increase the outlet pressure setting by turning the adjusting screw (key 35) clockwise. Decrease the outlet pressure setting by turning the adjusting screw counterclockwise.
4. When the desired pressure is obtained, hold the adjusting screw (key 35) in place and tighten the locknut (key 34).

## Shutdown



### WARNING

To avoid personal injury or property damage due to explosion or damage to regulator or downstream components during shutdown, release downstream pressure to prevent an overpressure condition on the diaphragm of the regulator.

1. Close the nearest upstream shut-off valve.
2. Close the nearest downstream shut-off valve.
3. Open the vent valve between the regulator and the downstream shut-off valve nearest to it.
4. A Type 627BM, 627BHM or 627BMR Regulator requires venting the control line and downstream pressure from the regulator before maintenance. The pressure between these shut-off valves is released through the open regulator because the disk assembly remains open in response to the decrease in control line pressure.

## Maintenance

Unless otherwise specified, the following maintenance procedures apply to all types of regulators. For a summary of maximum torque values required for all types of regulators, refer to Table 4.

Due to normal wear, damage from external sources or debris in the air or gas line, regulator parts such as the disk assembly orifice and diaphragm must be inspected periodically and replaced as necessary to ensure correct performance. The frequency of inspection and replacement depends upon the severity of conditions and the requirements of state and federal laws. Normal wear of the orifice and disk assembly is accelerated with high pressure drops and with large amounts of impurities in the flow stream. Instructions are given below for replacing the disk assembly orifice, diaphragm and O-rings. These procedures may also be used for disassembly required for inspection and replacement of other parts.

## Problem Indication for Type 627BM Regulator



### WARNING

Isolate the regulator from all pressure to avoid personal injury and equipment damage due to explosion or sudden release of process pressure. Cautiously release pressure from the regulator before attempting disassembly.

The vent assembly is equipped with a relief indicator (key 49, Figure 7). The cap for the relief indicator snaps over the vent assembly opening. If the relief valve opens wide, exhaust gas pops the cap off the screen vent assembly opening indicating a problem with the regulator. If the cap pops off, refer to the shutdown and to the Body Area Maintenance Procedures to inspect the disk assembly and orifice.

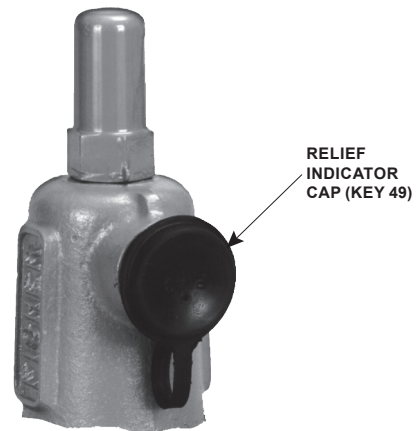

Figure 3. Relief Indicator

If the disk assembly and orifice are not damaged, refer to the Diaphragm and Spring Case Area Maintenance Procedures in this section.

The disk assembly and orifice can be inspected, removed and replaced without removing the regulator body from the line connections. Refer to the Body Area Maintenance Procedures.

## Body Area Maintenance Procedures

These procedures are for gaining access to the disk assembly orifice, diaphragm casing O-ring and stem assembly. All pressure must be released from the diaphragm casing before performing these steps.

While using the following procedures, refer to Figures 6 through 8 for key number locations.

### Replacing the Disk Assembly and Orifice

1. To inspect and replace the disk assembly (key 9) or orifice (key 2), remove the cap screws (key 36) and separate the diaphragm casing (key 5) from the body (key 1).
2. Inspect and, if necessary, remove the orifice (key 2). If removed, coat the threads of the replacement orifice with lubricant and torque to values shown in Table 4.

#### Note

Only install a 9/16 in. / 14.3 mm orifice on Types 627BM, 627BMR and 627BHM

3. Inspect the disk assembly (key 9) and if necessary to replace, skip to steps 7 through 12 to remove the stem assembly from the lower casing. The disk assembly cannot be replaced without removing the trim from the lower casing.

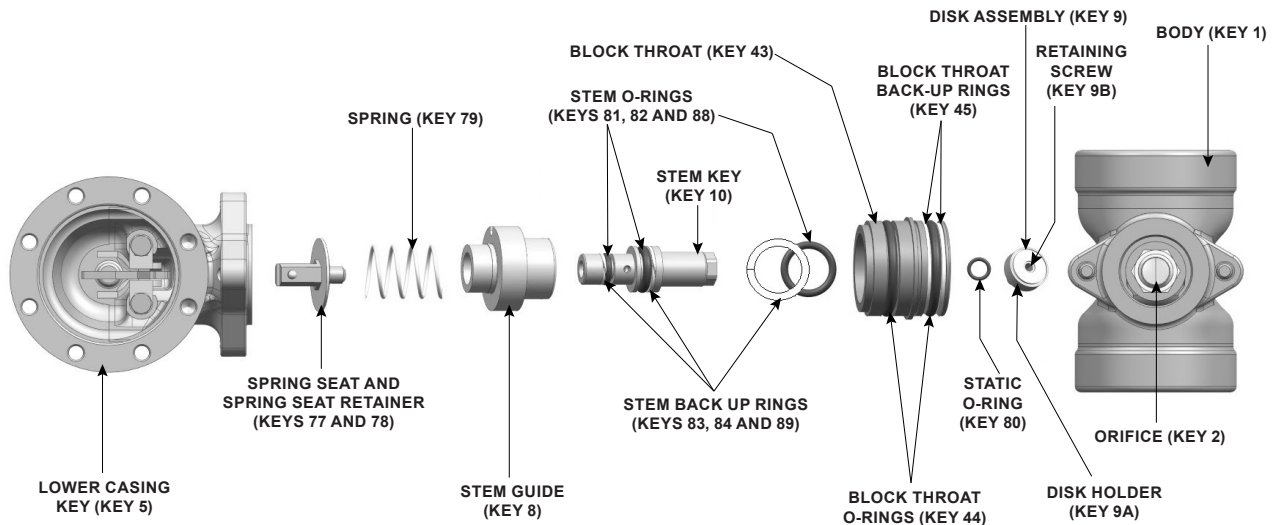

Figure 4. Stem Assemblies

4. To remove the disk assembly (key 9) once the stem assembly has been removed from the lower casing, hold the stem (key 10) in place by securing a wrench on the spring seat retainer (key 78) and loosen the disk assembly with a 5/32 in. / 3.97 mm allen wrench inserted into the center of the disk. Inspect and, if necessary, replace the static O-ring (key 80) if the disk assembly is removed.
  5. Verify that the passageway through the center of the disk assembly (key 9) is clear of any blockages.
  6. Once disk maintenance is complete, slide stem assembly into diaphragm casing (key 5), skip to Diaphragm and Spring Case Area Maintenance Procedure section to build the actuator.
- ### Stem Assembly Maintenance
7. Use steps 8 through 22 to remove and replace the stem assembly.
  8. Remove the adjusting screw cap (key 36), loosen the lock nut (key 34) and turn the adjusting screw (key 35) counterclockwise until all compression is removed from the control spring (key 32).
  9. Remove the spring case cap screws (key 37) and lift off the spring case (key 29).
  10. Remove the diaphragm limiter O-ring and diaphragm limiter (keys 51 and 50, on Type 627BHM only). Remove the diaphragm assembly by tilting it so that the pusher post (key 19) slips off the lever (key 15).
  11. Unhook the lever (key 15) from the spring retainer (key 78) to free the stem assembly.
  12. To remove stem assembly, insert a screw driver blade into the groove provided in the blocked throat (key 43) and pry it out of the diaphragm casing (key 5). Inspect and replace parts as necessary.
  13. To disassemble stem assembly, hold spring seat retainer (key 78) while loosening the disk assembly with a 5/32 in. / 3.97 mm allen key inserted into the center of the disk assembly (key 9). Slide blocked throat (key 43) off of stem.
  14. While holding stem (key 10) from where the disk assembly attaches, unscrew spring seat retainer (key 78) which will loosen the spring (key 79) and allow the stem to slide out of the stem guide (key 8).
  15. Inspect and if necessary, replace blocked throat O-rings (key 44) and back-up rings (key 45).
  16. Apply lubricant to replacement blocked throat O-rings (key 44) and back-up rings (key 45).
  17. Apply lubricant to the replacement stem O-rings (keys 81, 82 and 88) and stem back-up rings (keys 83, 84 and 89) and install on the stem (key 10).
  18. To assemble stem assembly, insert stem (key 10) into stem guide (key 8).
  19. Apply a small amount of thread lock to the spring seat retainer (key 78). Compress spring (key 79) with spring seat (key 77) and torque spring seat retainer (key 78) to torque values shown in Table 4 while holding stem. Excess thread lock can interfere with the operation of the regulator and potentially create unsafe conditions.
  20. Insert stem assembly into blocked throat (key 43).
  21. Place disk assembly O-ring (key 80) on disk assembly (key 9). For the Nitrile (NBR) disk, insert the retaining screw (key 9B) through the disk holder assembly (key 9). Apply lubricant to the static O-ring (key 80) and slide onto the back of the retaining screw (key 9B). Install disk assembly on stem (key 10) and torque to torque values shown in Table 4 while holding spring seat retainer (key 78).
  22. Slide stem assembly into diaphragm casing (key 5).
  23. Continue to Diaphragm and Spring Case Area Maintenance Procedures.

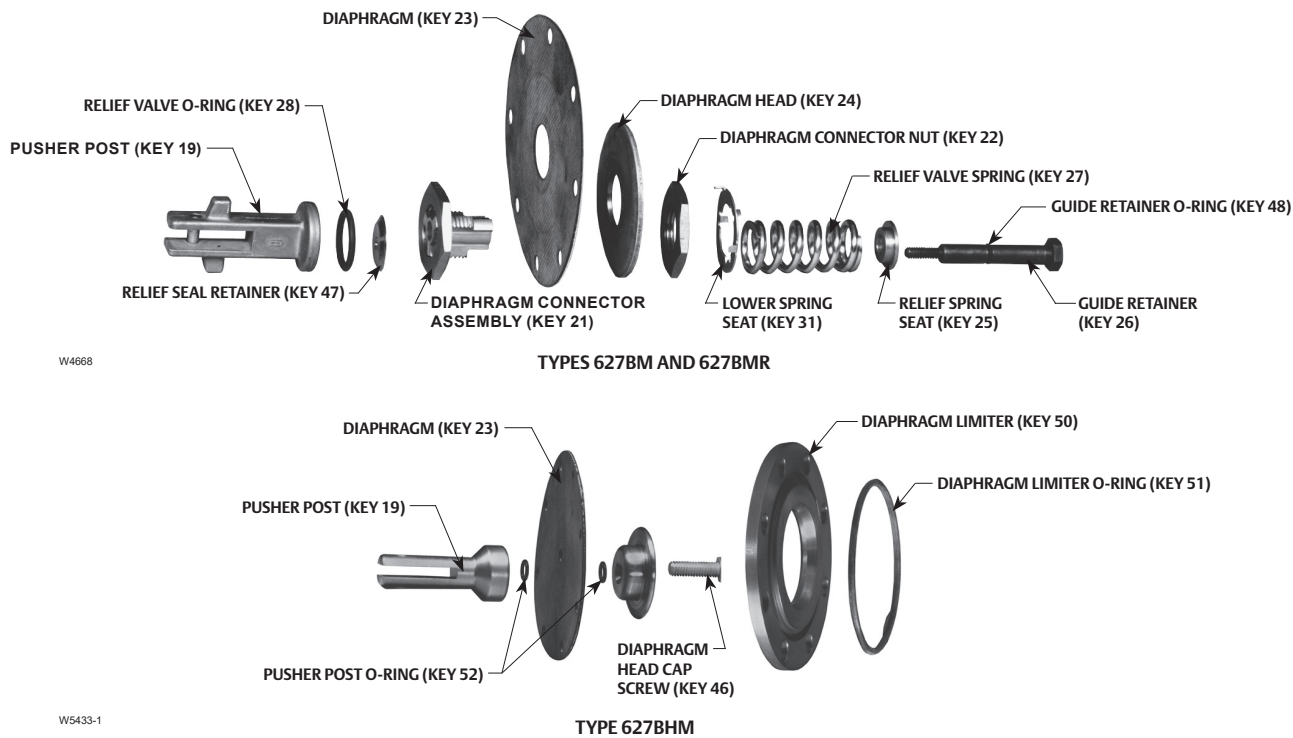

Figure 5. Diaphragm Assemblies

## Diaphragm and Spring Case Area Maintenance Procedures

These procedures are for gaining access to the control spring, diaphragm assembly and lever assembly. All spring pressure must be released from the diaphragm casing before these steps can be performed.

While using the following procedures, refer to Figures 6 through 8 for key number locations.

1. Remove the adjusting screw cap (key 36), loosen the lock nut (key 34) and turn the adjusting screw (key 35) counterclockwise until all compression is removed from the control spring (key 32).
2. Remove the spring case cap screws (key 37), the nameplates and lift off the spring case (key 29). If changing the control spring (key 32) or repositioning the spring case (key 29) is the only maintenance required, install the replacement control spring or rotate the spring case so it is correct for the application. Skip to step 21. For diaphragm area maintenance, continue with step 3.
3. Remove the diaphragm limiter O-ring and diaphragm limiter (keys 51 and 50, on the Type 627BHM only). Remove the diaphragm assembly by tilting it so that the pusher post (key 19) slips off the lever (key 15).
4. If it is necessary to replace the lever assembly, remove the lever cap screws (key 18).
5. Install the replacement lever (key 15) into the lever retainer (key 16) by inserting the lever pin (key 17). Secure the lever assembly into the diaphragm casing with the cap screws (key 18) and torque the cap screws to torque values shown in Table 4.

## Perform steps 6 through 11 for Types 627BM and 627BHM Variations Regulators only:

6. For Types 627BM and 627BHM Regulators (Figures 6 and 8), use steps 7 through 11 to disassemble and reassemble the diaphragm assembly.
7. Remove the diaphragm head cap screw (key 46), lower spring seat (key 31, Type 627BM) and diaphragm head (key 24). On the Type 627BHM, remove the pusher post O-rings (key 52). Separate the diaphragm (key 23) from the pusher post (key 19).
8. Install the diaphragm (key 23), in reverse order in step 7, on the pusher post (key 19), insert and finger tighten the diaphragm head cap screw (key 46).
9. Hook the pusher post on the lever (key 15), then turn the diaphragm (key 23) to match the holes in the diaphragm with the holes in the spring casing.
10. Unhook the pusher post from the lever (key 15) and torque the diaphragm head cap screw (key 46) to torque values shown in Table 4.
11. Hook the pusher post on the lever (key 15) and check the hole alignment. If necessary, loosen the cap screw (key 46) and reposition the diaphragm (key 23) on the pusher post (key 19). Retorque the screw (see step 10). Skip to step 20.

## Perform steps 12 through 19 for Type 627BMR Variation Regulator only:

12. For Type 627BMR Regulator (Figure 7), use steps 13 through 19 to disassemble and reassemble the diaphragm assembly.



13. Remove the guide retainer (key 26) and separate the diaphragm parts. Refer to Figure 7 for the sequence of parts.
14. To remove the diaphragm (key 23), remove the diaphragm connector nut (key 22) and lift off the diaphragm head (key 24) and diaphragm (key 23) from the connector assembly (key 21). Do not attempt to disassemble the connector assembly (key 21).
15. Position the replacement diaphragm (key 23) on the connector assembly (key 21), install the diaphragm head (key 24) and connector nut (key 22), then torque to torque values shown in Table 4.
16. If necessary, replace the guide retainer O-ring (key 48) and, set the guide retainer (key 26) aside, ready for assembly.
17. On the pusher post (key 19) install the relief seal O-ring (key 28) and apply lubricant. Also, install the relief seal retainer (key 47), diaphragm connector assembly (key 21, with attached parts) relief spring (key 27), upper relief spring seat (key 33) and guide retainer (key 26). Torque the guide retainer (key 26) to torque values shown in Table 4.
18. Hook the pusher post (key 19) (with attached parts) on the lever (key 15) to check the alignment of the holes in the diaphragm with the holes in the spring casing. If the holes do not line up, unhook the pusher post from the lever, hold the pusher post and rotate the diaphragm to the correct position.
19. Install the lower spring seat (key 31) over the relief spring so it rests flat on the connector nut (key 22).
20. Insert the diaphragm assembly into the diaphragm casing (key 5) and hook the pusher post on the lever (key 15).
21. Install the control spring (key 32) and upper spring seat (key 33) and apply lubricant to the upper spring seat (key 33).
22. Install the spring case (key 29) so that the screened vent assembly (key 30) is in the correct position for the application. Place the nameplates over the screw holes, insert the spring case cap screws (key 37) and finger tighten.
23. Screw in the adjusting screw (key 35) to put slack into the diaphragm (key 23).
24. Using a crisscross pattern, finish tightening the spring case cap screws (key 37) to torque values shown in Table 4.
25. If necessary, refer to the installation and/or the Startup and Adjustment procedures.
26. Install the adjusting locknut (key 34) after regulator adjustment.

## Parts Ordering

When corresponding with your local Sales Office about this equipment, always reference the equipment serial number or FS number that can be found on the nameplate.

When ordering replacement parts, reference the key number of each needed part as found in the following parts list. Separate kits containing all recommended spare parts are available.

\*Recommended spare part.

1. Bodies can be used for both standard and NACE constructions.

## Parts List

		Note
		<b>In this parts list, parts marked NACE are intended for corrosion-resistant service as detailed in the NACE International Standard MR0175.</b>
Key	Description	Part Number
	Type 627BM Part Kit with SST/Nylon (PA) trim (includes keys 9, 23, 44 and 45)	R627BMX0P02
	Type 627BHM Parts Kit with SST/Nylon (PA) trim (includes keys 9, 23, 44 and 45)	R627BHMx012
1	Body <sup>(1)</sup>	
	Ductile iron	
	1000 psig / 69.0 barg maximum inlet pressure	
	1 NPT	30B3048X012
	2 NPT	30B3096X012
	Steel	
	2000 psig / 138 barg maximum inlet pressure	
	1 NPT	30B3051X012
	2 NPT	30B7452X012
	Steel, CL600 RF flanged	
	1500 psig / 103 barg maximum inlet pressure	
	NPS 1 / DN 25	40B6754X012
	NPS 2 / DN 50	40B6756X012
	Steel, CL300 RF flanged	
	750 psig / 51.7 barg maximum inlet pressure	
	NPS 1 / DN 25	41B8978X012
	NPS 2 / DN 50	41B8808X012
	Steel, CL150 RF flanged	
	290 psig / 20.0 barg maximum inlet pressure	
	NPS 1 / DN 25	43B8656X022
	NPS 2 / DN 50	44B0666X012
	Steel, BWE	
	1000 psig / 69.0 barg maximum inlet pressure	
	NPS 1 / DN 25	33B6723X012
	NPS 2 / DN 50	38B1688X012
	Steel, PN 16/25/40 RF	
	580 psig / 40.0 barg maximum inlet pressure	
	NPS 1 / DN 25	44B0386X012
	NPS 2 / DN 50	44B3342X012
2*	Orifice	
	9/16 in. / 14.3 mm	
	Aluminum	1C4252X0012
	303 SST	1C425235032
	316 SST	1C4252X0022
3	Cap Screw (not shown), (2 required)	
	Steel	1A560724052
	Stainless steel	1A5607X0052
5	Diaphragm Case	
	For Types 627BM, 627BMR, 627BHM	
	Ductile iron (not for Type 627BHM)	ERAA50626A0
	Steel	ERAA50625A0
8	Stem Guide	
	Stainless steel	ERAA51322A0
9*	Disk Assembly	
	316 Stainless steel holder and Nylon (PA) disk	ERAA49120A1
	316 Stainless steel holder and Nitrile (NBR) disk	ERAA57939A0
9A	Disk Holder	ERAA58278A0
9B	Retaining Screw	ERAA58277A0
10	Stem, 316 Stainless steel (NACE)	ERAA51314A0
14	Drive Pin, Stainless steel	ERAA49515A0
15	Lever, Carbon steel	20B3063X012
16	Lever Retainer, Plated steel	30B3097X012
17	Lever Pin	
	Stainless steel	10B3083X012
	316 Stainless steel (NACE)	10B3083X022

# 627B Series

KEY NUMBER	PART DESCRIPTION	ADJUSTMENT TOOL	PART NUMBER
2	Orifice	7/8 in. / 22.2 mm Socket	1C4252
3	Cap Screw/Ductile iron, Steel or Stainless steel Casing	3/8 in. / 9.53 mm Hex/Allen Wrench	1A5607
9	Disk Holder Assembly	5/32 in. / 3.97 mm Hex/Allen Wrench	ERAA49120
10	Stem	1/2 in. / 12.7 mm Socket	ERAA51314
35	Adjusting Screw	1/2 in. / 12.7 mm Adjustable End Wrench	10B3081
37	Cap Screw/Aluminum or Ductile iron Casing	1/4 in. / 6.35 mm Socket	1A3917
	Cap Screw/Steel or Stainless steel Casing	3/8 in. / 9.53 mm Socket	1A36832
78	Spring Seat Retainer	3/8 in. / 9.53 mm Socket	ERAA50115

Key	Description	Part Number	Key	Description	Part Number
18	Lever Cap Screw (2 required)		33	Upper Spring Seat, Plated steel	1D667125072
	Plated steel	10B7454X012	34	Locknut, Plated steel	1D667728982
	316 Stainless steel (NACE)	1B2905X0012	35	Adjusting Screw, Plated steel	
19	Pusher Post			For Types 627BM or 627BHM	10B3081X012
	For Type 627BM, Aluminum	10B3098X012		For Type 627BMR	10B3080X012
	For Type 627BMR, 316 Stainless steel	ERAA51240A0	36	Adjusting Screw Cap, Plastic	20B3082X012
	For Type 627BHM		37	Spring Case Cap Screw, Plated steel	
	316 Stainless steel	ERAA51241A1		(8 required)	
	NACE	ERAA51241A0		For Aluminum or Ductile iron diaphragm case	1A391724052
21	Diaphragm Connector (for Type 627BMR only)			For Steel diaphragm case	1A368324052
	Stainless steel	28B8832X012		For Stainless steel case and body	1A3683X0062
22	Diaphragm Connector nut (for Type 627BMR only)			For Aluminum case and SST body	1A3917X0062
	Stainless steel	10B7449X012		For Type 627BHM, Steel diaphragm case	1A346424052
23*	Diaphragm		43	Blocked Throat, Stainless steel	ERAA51294A0
	Nitrile (NBR)		44*	Blocked Throat O-ring	
	For Type 627BM with Aluminum			(For Types 627BM, 627BHM or 627BMR only),	
	or Ductile iron diaphragm case	10B3069X012		Nitrile (NBR) (2 required)	ERAA19159A0
	For Type 627BM with Steel diaphragm case	10B8735X012	45*	Blocked Throat Back-up Ring	
	For Type 627BMR with Aluminum			For Types 627BM, 627BHM or 627BMR only),	
	or Ductile iron diaphragm case	10B3068X012		Polytetrafluoroethylene (PTFE) (2 required)	10B3106X012
	For Type 627BMR with Steel diaphragm case	10B8736X012	46	Diaphragm Head Cap Screw, Steel	
	For Type 627BHM with Steel diaphragm case			For Type 627BM	1B290524052
	(diaphragm is Neoprene (CR) with			For Type 627BHM	1C379124052
	Nylon (PA) fabric)	12B0178X012	47	Relief Seal Retainer (For Type 627BMR only)	
24	Diaphragm Head			Stainless steel	10B7445X012
	For Type 627BM, Plated steel	1D666428982	48*	Guide Retainer O-ring (For Type 627BMR only)	
	For Type 627BMR, Plated steel	10B3071X012		Nitrile (NBR)	1D682506992
	For Type 627BHM, 416 Stainless steel	12B0175X012	49	Relief Indicator (For Type 627BR or	
25	Relief Spring Seat (For Type 627BMR only)			627BMR only), Rubber (not shown)	30B3100X012
	Steel	10B7446X012	50	Diaphragm Limiter	
26	Guide Retainer (For Type 627BMR only)			(For Type 627BHM only)	22B0176X012
	Stainless steel	10B7450X012	51*	Diaphragm Limiter O-ring	
27	Relief Spring (For Type 627BMR only)			(For Type 627BHM only)	ERAA19160A5
	Plated steel	10B6757X012	52*	Pusher Post O-ring (2 required)	
28*	Relief Seal O-ring (For Type 627BMR only)	ERAA19157A0		(For Type 627BHM only)	1C853806992
29	Spring Case		58	Pipe Plug, Zinc	1D8293T0022
	For Type 627BM or 627BMR		67	Drive Screw, 18-8 Stainless steel	1A368228982
	Ductile iron	30B3055X012	72	Pipe Plug, Zinc-plated steel	1A767524662
	Steel	30B3102X012	77	Spring Seat, Stainless steel	ERAA50118A0
	For Type 627BHM		78	Spring Seat Retainer, Stainless steel	ERAA50115A0
	Steel	30B3102X012	79	Spring	
30	Screened Vent Assembly, Plastic	10B3093X012		Stainless steel	ERAA50082A0
31	Lower Spring Seat, Plated steel			NACE	ERAA50061A0
	For Type 627BM	1D666625072	80*	O-ring (Disk Holder)	ERAA49442A0
	For Type 627BMR	20B3073X012	81*	O-ring (Stem - Small)	ERAA49363A0
32	Control Spring, Plated steel		82*	O-ring (Stem - Large)	ERAA49364A0
	5 to 20 psig / 0.34 to 1.4 barg, Yellow	10B3076X012	83*	Back-up Ring (Small)	ERAA49365A0
	15 to 40 psig / 1.0 to 2.8 barg, Green	10B3077X012	84*	Back-up Ring (Large)	ERAA49366A0
	35 to 80 psig / 2.4 to 5.5 barg, Blue	10B3078X012	88*	O-ring (Blocked Throat)	1D541506992
	70 to 150 psig / 4.8 to 10.3 barg, Red	10B3079X012	89*	Back-up Ring (Blocked Throat)	ERAA51338A0
	140 to 250 psig range / 9.7 to 17.2 barg, Blue,				
	used for Type 627BHM	10B3078X012			
	240 to 500 psig range / 16.5 to 34.5 barg, Red,				
	used for Type 627BHM	10B3079X012			

\*Recommended spare part.



# 627B Series

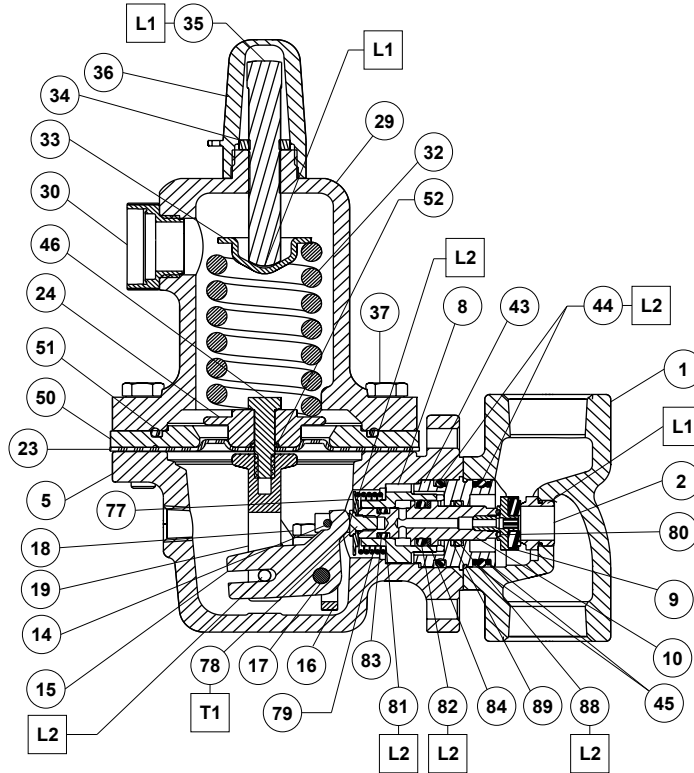

ERAA49929\_AB

**APPLY LUBRICANT<sup>(1)</sup>**

L1 = MULTI-PURPOSE LITHIUM POLYMER TYPE GREASE

L2 = EXTREME LOW-TEMPERATURE BEARING GREASE

T1 = APPLY THREADLOCK

1. Lubricants must be selected such that they meet the temperature requirements.

**Figure 8. Type 627BHM Regulator Assembly**

✉ Webadmin.Regulators@emerson.com

Facebook.com/EmersonAutomationSolutions

🔍 Fisher.com

LinkedIn.com/company/emerson-automation-solutions

X.com/emr\_automation

**Emerson**

**Americas**

McKinney, Texas 75069 USA  
T +1 800 558 5853  
+1 972 548 3574

**Europe**

Bologna 40013, Italy  
T +39 051 419 0611

**Asia Pacific**

Singapore 128461, Singapore  
T +65 6777 8211

**Middle East and Africa**

Dubai, United Arab Emirates  
T +971 4 811 8100

D104602X012 © 2021, 2025 Emerson Process Management Regulator Technologies, Inc. All rights reserved. 01/25  
Fisher™ is a mark owned by Fisher Controls International, LLC, an Emerson Company. The Emerson logo is a trademark and service mark of Emerson Electric Co. All other marks are property of their respective owners.

The contents of this publication are presented for informational purposes only, and while every effort has been made to ensure their accuracy, they are not to be construed as warranties or guarantees, express or implied, regarding the products or services described herein or their use or applicability. All sales are governed by our terms and conditions, which are available upon request. We reserve the right to modify or improve the designs or specifications of such products at any time without notice.

Emerson Process Management Regulator Technologies, Inc does not assume responsibility for the selection, use or maintenance of any product. Responsibility for proper selection, use and maintenance of any Emerson Process Management Regulator Technologies, Inc. product remains solely with the purchaser.

