

December 2008

168, 168H, and 68 Series Three-Way Switching Valves

Introduction

The 168 and 168H Series pneumatically operated three-way snap-acting switching valves (Figure 1) are used to switch pressures on and off in response to a predetermined change in an input signal pressure.

In operation, increasing pressure applied to the top of the diaphragm through port D (see Figure 2) moves the stem and upper range adjusting nut toward the trip lever. When the diaphragm pressure reaches the predetermined upper tripping pressure, the upper adjusting nut pivots the trip lever to move the rocker assembly to its alternate position, closing port C and opening port B. When decreasing pressure to the diaphragm at port D reaches the lower tripping pressure, the spring moves the stem and lower range adjusting nut to return the rocker to its original position, closing port B and opening port C.

The 68 Series (Figure 4) three-way snap-acting body assemblies can be used alone, or to form the valve body portions of 168 or 168H Series switching valves. With the addition of the lever knob (key 11, Figure 4) to a Type 68-1 body assembly, a Type 68-2 manual switching valve body assembly is formed.

Only personnel qualified through training or experience should install, operate, and maintain these valves. If there are any questions concerning these instructions, contact your local Sales Office before proceeding.



Figure 1. Exterior of 168 Series Switching Valve

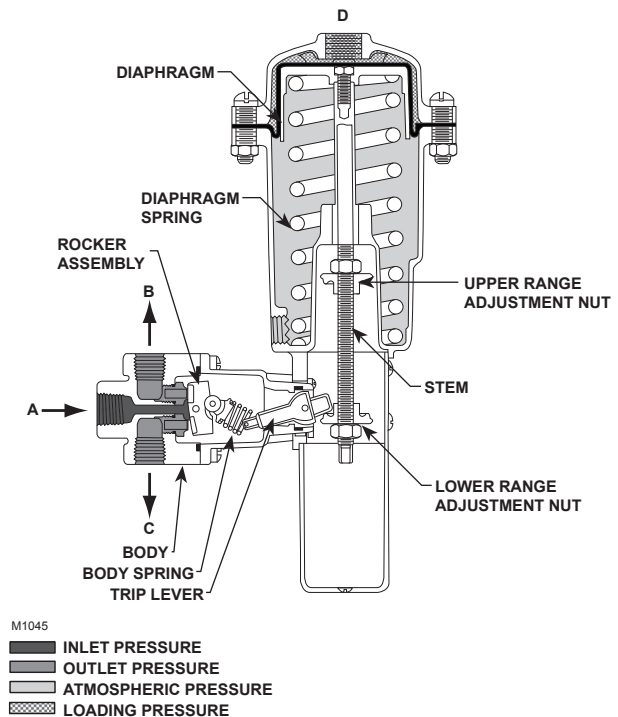

Figure 2. Construction Details of 168 Series Switching Valve



168, 168H, and 68 Series

Specifications

Maximum Allowable Pressures

Diaphragm

168 Series: 100 psi (6,90 bar)

168H Series: 150 psi (10,3 bar)

Body: See Table 1

Operative Temperature Limits⁽¹⁾

-10° to 150°F (-23° to 66°C)

Port Diameter

3/32-inch (2,38 mm)

Flow Coefficients

C_g : 7

Representative C_i : 35

Pressure Connections

1/4-inch NPT female

Approximate Weights

68 Series: 0.5 pound (0,23 kg)

168 Series: 3 pounds (1,36 kg)

168H Series: 5 pounds (2,27 kg)

1. This term is defined in ISA Standard S51.1-1979.

Table 1. Maximum Pressures and Spring Part Numbers

COMPLETE SWITCHING VALVE TYPE NUMBER	DIAPHRAGM PRESSURE CHANGE BETWEEN SWITCHING POINTS				DIAPHRAGM PRESSURE RANGE		KEY 8, FIGURE 3 DIAPHRAGM SPRING PART NUMBER AND COLOR CODE	MAXIMUM ALLOWABLE BODY PRESSURE		KEY 2D, FIGURE 4 BODY SPRING PART NUMBER AND COLOR CODE	BODY ASSEMBLY TYPE NUMBER
	Minimum		Maximum					Psi	bar		
	Psi	bar	Psi	bar							
----	----	----	----	----	----	----	----	150	10,3	1U878037022, Metallic	68-2
168-1	10	0,69	58	4,00	2 to 60	0,14 to 4,14	1U877127142, green	150	10,3	1U878037022, Metallic	68-1
168-2	10	0,69	38	2,62	2 to 40	0,14 to 2,76	1U879727142, yellow	150	10,3	1U878037022, Metallic	68-1
168-3	10	0,69	58	4,00	2 to 60	0,14 to 4,14	1U877127142, green	40	2,76	1U854537022, Yellow	68-3
168-4	7	0,48	38	2,62	2 to 40	0,14 to 2,76	1U879727142, yellow	40	2,76	1U854537022, Yellow	68-3
168H-1	20	1,38	100	6,90	50 to 150	3,45 to 10,3	1U877127142, green	150	10,3	1U878037022, Metallic	68-1
168H-2	20	1,38	65	4,48	35 to 100	2,41 to 6,90	1U879727142, yellow	150	10,3	1U878037022, Metallic	68-1
168H-3	20	1,38	100	6,90	50 to 150	3,45 to 10,3	1U877127142, green	40	2,76	1U854537022, Yellow	68-3
168H-4	16	1,10	65	4,48	35 to 100	2,41 to 6,90	1U879727142, yellow	40	2,76	1U854537022, Yellow	68-3

Installation

Maximum allowable pressures for the diaphragm and body are given in the Specifications section above and Table 1 respectively. If pressure to the unit is capable of exceeding these values, install relief valves or other overpressure protection devices in the pressure lines.

The 68 Series body assemblies can be installed in any position. Position a 168 or 168H Series switching valve so that moisture and other foreign material cannot enter either the vent (key 17, Figure 3) or the small hole in the end of the stem protector (key 10, Figure 3).

When the switch is in service, inspect the vent opening periodically to ensure that it is not plugged.

Before installing, be certain that the valve body portion and adjacent pipes are free of pipe scale and other foreign material. Use accepted piping practices when installing.

For the 168 and 168H Series switching valves, a mounting bracket (key 15, Figure 3) is available. This mounting bracket is suitable for use with a 2-inch (50,8 mm) (nominal) pipestand. Mounting parts that can be used to attach a 168 or 168H Series switching valve to the yoke of a control valve actuator are also available.

Pipe the common pressure line to port A (the connection in the end of the valve body portion). With one port (either B or C) plugged, the unit can be used as an on/off switch. Note that flow cannot pass from port B to port C or from port C to port B.

168 and 168H Series Adjustment

Determine the desired upper and lower switching pressures (the high and low values of diaphragm pressure at which the valve is to switch). Refer to Table 1 to ensure that these pressures are within the diaphragm pressure range and that the diaphragm pressure change between the switching pressures is within the minimum and maximum limits shown.

Adjust the unit as follows. Key numbers used in this procedure are shown in Figure 3 except where indicated.

1. Remove screws and stem protector (keys 11 and 10).
2. To set the lower switching pressure:
 - 2.1 Apply a pressure to the diaphragm case (key 1) equal to the lower switching point.
 - 2.2 Loosen locknut (key 9). Use a screwdriver to move the trip lever (key 2C) so that the visible end points away from the spring case (key 2A). It might be necessary to back the adjusting nut (key 7) and locknut away from the trip lever to do this.
 - 2.3 Rotate the adjusting nut toward the trip lever until the nut just moves the trip lever to the alternate position.
3. To set the upper switching pressure:
 - 3.1 Apply a pressure to the diaphragm case (key 1) equal to the upper switching pint.
 - 3.2 Loosen the locknut on the upper range adjusting nut. Use a screwdriver to move the trip lever (key 2C) so that its visible end points toward the spring case (key 2A). It may be necessary to back the adjusting nut and locknut away from the trip lever to do this.
 - 3.3 Rotate the upper range adjusting nut toward the trip lever until the nut just moves the trip lever to its alternate position.
4. Tighten each locknut against its respective adjusting nut.
5. Replace stem protector and machine screws (key 11).

168 and 168H Series Manual Reset Operation

Without Manual Reset Switch

With one adjusting nut removed, the unit will switch with high (or low) diaphragm pressure and will remain in that position until the stem protector (key 10, Figure 3) is removed and the trip lever (key 2C, Figure 4) is manually moved to its normal position. Remove the range adjusting nut (and its locknut) located nearer the spring case (key 2A, Figure 3) if switching at low diaphragm pressure only is desired. Remove the other adjusting nut and locknut if switching with high diaphragm pressure only is desired. The remaining adjusting nut can be adjusted by the appropriate steps given in the Adjustment section.

To reset the unit after it has switched, remove the machine screws and stem protector (keys 11 and 10, Figure 3), and use a screwdriver to return the trip lever (key 2C, Figure 4) to its normal position.

With Manual Reset Switch

When a manual reset switch (see Figure 3) is used on a unit in the single-pressure trip mode (either high or low pressure setpoint requiring only one adjusting nut), the end of the reset lever (key 20) in contact with the trip lever (see section DD, Figure 3) should be on the opposite side of the trip lever from the adjusting nut.

If it is necessary to change the reset lever position, remove the self tapping screws (key 23). Slide the lever out of the stem protector slots, and position it on the other side of the trip lever and re-insert. Re-attach the indicator tag with the self-tapping screws, making sure the arrow on the tag points in the same direction as that required to reset the switch.

168, 168H, and 68 Series

Maintenance



WARNING

To avoid personal injury or property damage from sudden pressure release or uncontrolled process fluid, isolate the switching valve from the process, release process pressure, and vent any loading pressure before starting disassembly.

Because of the care Fisher® takes in meeting all manufacturing requirements (heat treating, dimensional tolerances, etc.), use only replacement parts manufactured or furnished by Fisher.

Replacing 168 or 168H Series Diaphragm

Key numbers in this procedure are shown in Figure 3.

1. For a 168 Series switching valve, unscrew the hex nuts (key 13) and remove machine screws (key 12).
2. For a 168H Series switching valve, loosen and remove the machine screws (key 12).
3. Remove diaphragm case (key 1).
4. Remove diaphragm (key 4). Install the new diaphragm with the rubber side of the diaphragm facing the pressure chamber; the fabric side of the diaphragm should face the actuator spring (key 8).
5. Replace diaphragm case, cap screws, and hex nuts (where applicable).

Replacing 68 Series Body Assembly Parts

Note

Omit steps 1, 2, 12, 13, and 14 if maintenance will be on a Type 68-2 manual switching valve. Key numbers used in this procedure are shown in Figure 4 except where indicated.

1. Remove machine screws and stem protector (keys 11 and 10, Figure 3).
2. Unscrew and remove machine screws (key 8) that attach the body assembly to the spring case (key 2A, Figure 3).
3. Using care to avoid dropping the rocker or roller assemblies (keys 3 and 5), remove machine screws (key 9) and separate the body (key 1) from the valve spring case assembly (key 2).

4. Carefully drive out trip lever pin (key 2E).
5. Remove trip lever (key 2C) and attached spring (key 2D) from spring case.
6. Install new O-ring (key 2B) in spring case.
7. Re-install trip lever and attached spring into spring case.
8. Carefully drive trip lever pin (key 2E) into the mating holes in the spring case and trip lever.
9. Replace O-ring (key 6) in valve body. Coat the replacement O-ring with a good quality elastomer lubricant and sealant.
10. Use a new roller assembly (key 5) and (if necessary) a new rocker assembly (key 3). Assemble the spring case to the valve body so that the roller assembly mates with the end of the spring and the roller rests in the notch of the rocker assembly.
11. Insert and tighten machine screws (key 9).
12. Lubricate the portion of the trip lever (key 2C) that contacts the adjusting nuts (key 7, Figure 3) with a good quality general-purpose grease.
13. To attach the body assembly to the spring case (key 2A, Figure 3), position the body assembly correctly in respect to the spring case mounting holes. Install and tighten machine screws (key 8).
14. Re-install stem protector and machine screws (keys 10 and 11, Figure 3).

Replace Manual Reset Switch Parts

Key numbers in this section refer to Figure 3.

1. Remove the self-tapping screws (key 23) and indicator tag (key 24) from the stem protector (key 10).
2. Remove lever (key 20) and pin (key 22) from the stem protector. Inspect parts and replace as necessary.
3. Insert pin lever and replace lever in stem protector, making sure the lever is in the proper position for the trip mode (see 168 or 168H Series Manual Reset Operation section).
4. Attach the indicator tag to the stem protector with the self tapping screws, making sure the arrow on the tag points in the same direction as that required to reset the switch.

168, 168H, and 68 Series

Parts Ordering

When corresponding with the local Sales Office about this equipment, state the type number and all other pertinent data found on the nameplates (key 14, Figure 3; key 10, Figure 4). When ordering replacement parts, also specify the complete 11 character part number of each part required.

Parts List

168 and 168H Series (Figure 3)

Key	Description	Part Number
1	Diaphragm Case, Aluminum	2U876208012
2	Spring Case Assembly (consists of keys 2A and 2B)	1U8763000A2
2A	Spring Case, Aluminum	4U876408012
2B	Spring Case Bushing, Steel and Polytetrafluoroethylene (PTFE)	1U876599402
3	Diaphragm Piston, Aluminum	
	168 Series	1U876608012
	168H Series	1U880009022
4*	Diaphragm, Dacron [®] (1)/Nitrile (NBR)	
	168 Series	2U876702472
	168H Series	1U879902472
5	Machine Screw, Plate steel	
	168 Series	1U876832982
	168H Series	1U880132982
6	Stem, SST	1U876935162
7	Range Adjusting Nut, SST (2 required)	1U877046172
8	Spring, Plate steel	See Table 1
9	Hex Nut, Zinc plate steel (2 required)	1A680324122
10	Stem Protector Plastic	2U877206992
11	Machine Screw, Plate steel (4 required)	1A331928982
12	Machine Screw, Plate steel	
	168 Series (8 required)	1H340328992
	168H Series (16 required)	1H340328992

Key	Description	Part Number
13	Hex Nut (168 Series only), Zinc plate steel (8 required)	1A345724122
14	Nameplate, Aluminum	1U8773X00A2
15	Mounting Bracket, Steel	3P426825022
16	Cap Screw, Plate steel (2 required)	1A381624052
17	Vent Screen, Monel [®] (2)	0W086343062
18	Body Assembly	See 68 Series parts list
19	Spacer (168H Series only), Aluminum	1U879809022
20	Reset Lever, Aluminum	13A7467X012
21	Knob, 303 (303 SST)	1U879335032
22	Pin	13A7468X012
23	Machine Screw, Steel (2 required)	13A7834X012
24	Indicator Tag, SST	13A7835X012
25	Tubing, Copper (not shown) (specify length)	0500201701W
26	Connector, Brass (not shown)	15A6002X202
27	Elbow, Brass (not shown)	15A6002X162

68 Series (Figure 4)

Key	Description	Part Number
1	Body, Aluminum	3U877608012
2	Spring Case Assembly (consists of keys 2A through 2F) Type 68-3 Type 68-1 or 68-2	1U8547000A2
2A	Spring Case, Aluminum	1U8777000A2
2B*	O-ring, Nitrile (NBR)	3U877808012
2C	Trip Lever, SST	1E220206992
2D	Spring, SST	1U877946172
2E	Trip Lever Pin, SST	See Table 1
2F	Spacer, Nylon	1U878149062
3*	Rocker Assembly, Glass-filled nylon with polyurethane valve disks	1V175006162
4	Seat Ring, SST (2 required)	1U878206992
5	Roller Assembly, Aluminum and SST	1U878435032
6*	O-ring, Nitrile (NBR)	1U8786000A2
7	Rocker Pin, SST	1U879006562
8	Machine Screw, Plate steel (4 required)	1U879149062
9	Machine Screw, Plate steel (4 required)	10B6186X012
		1A327928982

*Recommended spare part.

1. Trademark is a mark owned by E.I. du Pont de Nemours and Co.
2. Trademark is a mark owned by Special Metals Corporation.

168, 168H, and 68 Series

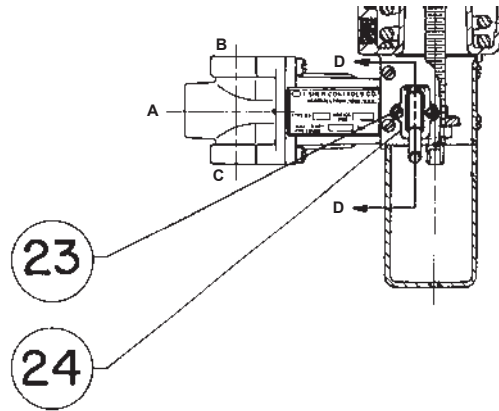
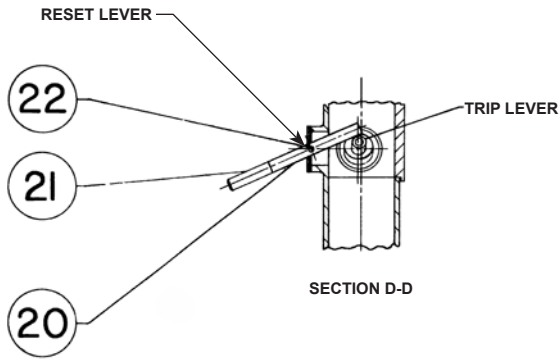

43A8117-B
B1199-1

DETAIL OF MANUAL RESET SWITCH FOR USE WITH EITHER 168 OR 168H SERIES

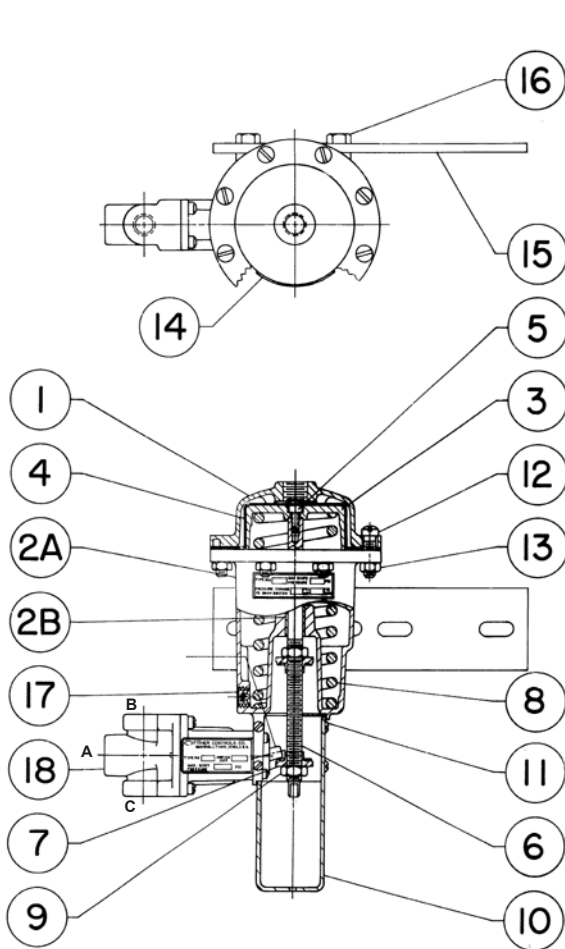

DU8774-D

168 SERIES

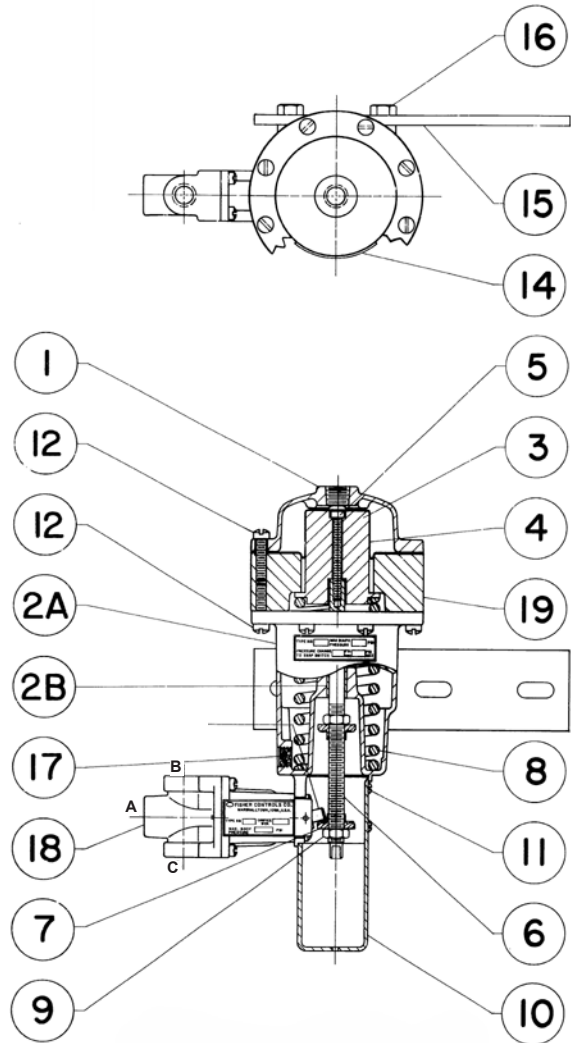

DU8796-D

168H SERIES

Figure 3. Switching Valve Constructions

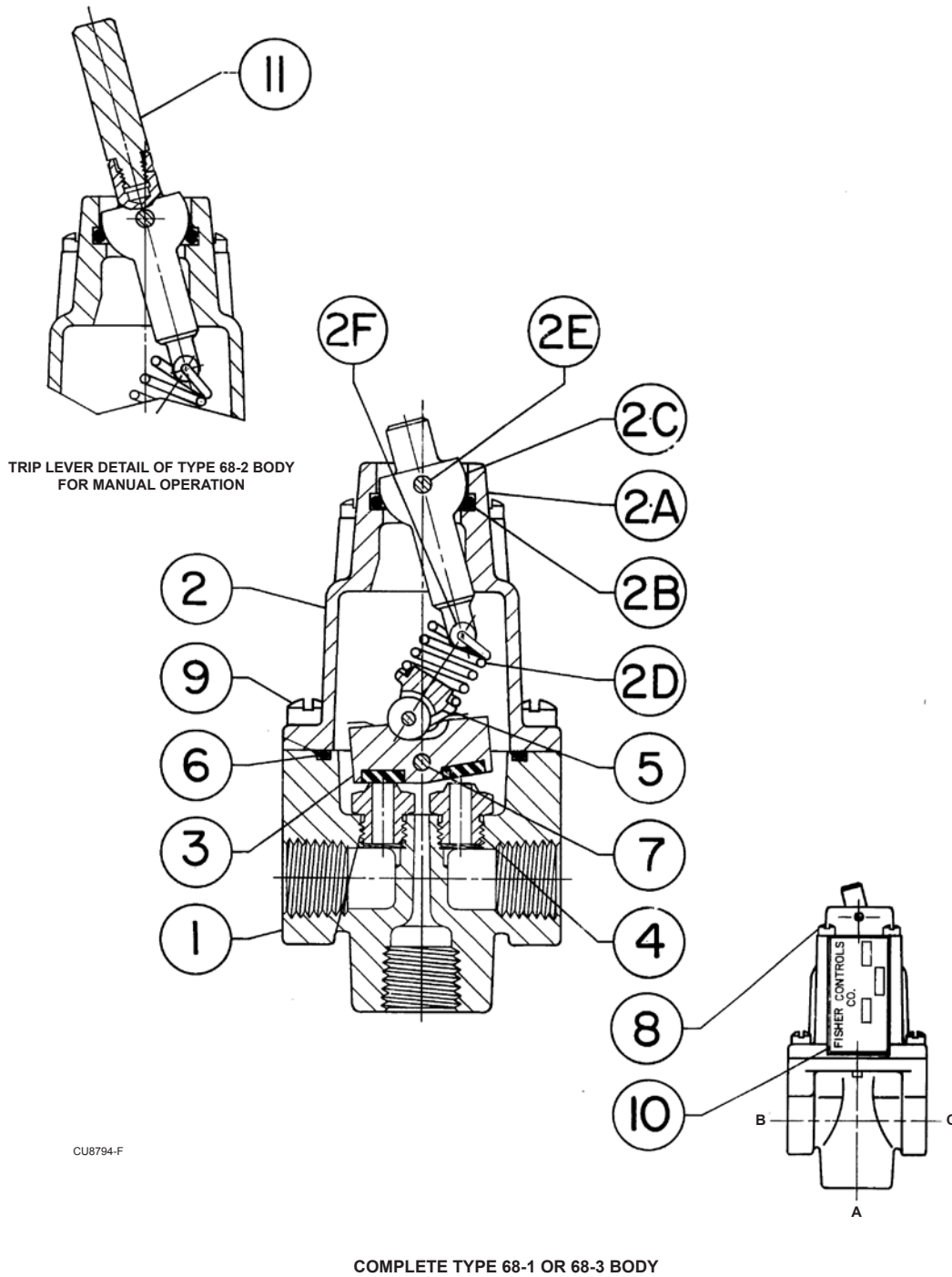

Figure 4. 68 Series Switching Valve Body Assemblies

168, 168H, and 68 Series

Industrial Regulators

Emerson Process Management Regulator Technologies, Inc.

USA - Headquarters
McKinney, Texas 75069-1872 USA
Tel: 1-800-558-5853
Outside U.S. 1-972-548-3574

Asia-Pacific
Shanghai, China 201206
Tel: +86 21 2892 9000

Europe
Bologna, Italy 40013
Tel: +39 051 4190611

Middle East and Africa
Dubai, United Arab Emirates
Tel: +971 4811 8100

Natural Gas Technologies

Emerson Process Management Regulator Technologies, Inc.

USA - Headquarters
McKinney, Texas 75069-1872 USA
Tel: 1-800-558-5853
Outside U.S. 1-972-548-3574

Asia-Pacific
Singapore, Singapore 128461
Tel: +65 6777 8211

Europe
Bologna, Italy 40013
Tel: +39 051 4190611
Gallardon, France 28320
Tel: +33 (0)2 37 33 47 00

TESCOM

Emerson Process Management Tescom Corporation

USA - Headquarters
Elk River, Minnesota 55330-2445 USA
Tel: 1-763-241-3238

Europe
Selmsdorf, Germany 23923
Tel: +49 (0) 38823 31 0

For further information visit www.emersonprocess.com/regulators

The Emerson logo is a trademark and service mark of Emerson Electric Co. All other marks are the property of their prospective owners. Fisher is a mark owned by Fisher Controls, Inc., a business of Emerson Process Management.

The contents of this publication are presented for informational purposes only, and while every effort has been made to ensure their accuracy, they are not to be construed as warranties or guarantees, express or implied, regarding the products or services described herein or their use or applicability. We reserve the right to modify or improve the designs or specifications of such products at any time without notice.

Emerson Process Management does not assume responsibility for the selection, use or maintenance of any product. Responsibility for proper selection, use and maintenance of any Emerson Process Management product remains solely with the purchaser.