

TOPWORX™

TopWorx™ TV-Series Valve Controllers

Installation, Operation & Maintenance Manual



EMERSON™

Emerson™

Emerson is a powerful, global, single source of process improvement technology and expertise. We help major companies in selected industries optimize their plants and processes to achieve higher quality, greater reliability and faster time to market, while steadily advancing productivity and profitability.

Emerson's technology know-how and application experience enable us to develop products and solutions that deliver the proven performance and reliability our customers expect when looking to build, connect, improve, and maintain their equipment and automation process.

Driven Without Compromise



Table of Contents

INSTALLATION ON ACTUATOR	4
NORMAL and REVERSE ACTING	4
MOUNTING	4
TVA (DOMED LID) DIMENSIONS and MATERIALS	5
TVF (DOMED LID) DIMENSIONS and MATERIALS	6
TVL (DOMED LID) DIMENSIONS and MATERIALS	7
TVH (DOMED LID) DIMENSIONS and MATERIALS	8
TVL (FLAT LID) DIMENSIONS and MATERIALS	9
TVH (FLAT LID) DIMENSIONS and MATERIALS	10
SHAFT DETAIL	11
SENSORS BASIC FUNCTION	12
SWITCH SETTING	12
GO™ SWITCH PUSH TO SET TARGETS	13
SWITCH OPTION D/S	14
SWITCH OPTION M	15
SWITCH OPTION T	16
SWITCH OPTION R	17
SWITCH OPTION P	18
SWITCH OPTION DS/RS/PS/MS/KS/LS: TV-LED WITH SPDT PROXIMITY SWITCHES	19
SWITCH OPTION E	20
SWITCH OPTION 42 and 52	21
SWITCH OPTION AM/AS: AS-I	22-23
SWITCH OPTION DM/DN	24-28
SWITCH OPTION PM/PB	29-30
4-20mA TRANSMITTER: OPTIONS EX/KX/MX/TX	31-34
MAINTENANCE, AREA CLASSIFICATIONS & SAFE USE INSTRUCTIONS.....	35

WARNING

To reduce the risk of death, serious injury or property damage:

- Personnel installing, maintaining, or operating this equipment must be qualified, must read, understand, and follow these instructions before proceeding.
- This document must be retained for future reference.
- Please contact local TopWorx representative for questions, clarifications, or comments.

Installation on Actuator

Normal and Reverse Acting

Normal acting is full clockwise (CW) when the process valve is closed and counterclockwise (CCW) when the process valve is open. *Reverse acting* is full CW when the process valve is open and CCW when the process valve is closed.

Indicator dome assemblies are designed to accommodate **both Normal and Reverse Acting units**. When the unit is Reverse Acting, the indicator dome assembly will have to be rotated.

The image to the right shows a TopWorx™ unit mounted parallel to the process valve in the closed position. The green arrow at the top shows the “normal acting” direction of travel to open the valve. This is the standard orientation of your unit unless otherwise specified and will be factory set to operate in this fashion.



Installation on Actuator Mounting

TopWorx™ has numerous mounting bracket kits available to meet your specific application, whether rotary or linear. Consult your local distributor or factory representative for ordering information. The illustration shows a direct Namur mount on a quarter turn valve. Refer to your mounting kit documentation for specific mounting instructions.

Installation Notes

1. Remove the upper housing of the unit to allow access to the target cam assembly.
2. Hold the unit above the mounting surface in the orientation in which you intend to mount. Rotate the shaft to align the tang with the actuator slot. In some cases, it may be necessary to rotate the target cam on the shaft to allow assembly. For most units the target cam is secured with a compression spring. Simply grasp the cam, push down, and realign the cam as required. On some units the target cam is secured with a snap ring. On these units, removal of the shaft from the base assembly will be required to change the orientation. Once removed from the base assembly, remove the snap ring securing the target cam and rotate as required.
3. Use caution not to allow undue axial (thrust) load on the shaft.
4. Cycle the valve a couple of times prior to final tightening of the mounting kit hardware. This allows the shaft to self-center in the pinion slot, or coupler. Refer to the dimensions and materials section of this document for appropriate tightening torque.
5. Always use sound mechanical practices when torquing down any hardware or making pneumatic connections. Refer to the Integrated Pneumatic Control Valves section for detailed information on pneumatic connections.
6. This product comes shipped with conduit covers to protect the internal components from debris during shipment and handling. It is the responsibility of the receiving and/or installing personnel to provide appropriate permanent sealing devices to prevent the intrusion of debris, and moisture, when stored outdoors, or when installed.
7. It is the responsibility of the installer, or end user, to install this product in accordance with the National Electrical Code (NFPA 70) or any other national or regional code defining proper practices.



Dimensions and Materials: TopWorx™ TVA (Domed Lid)

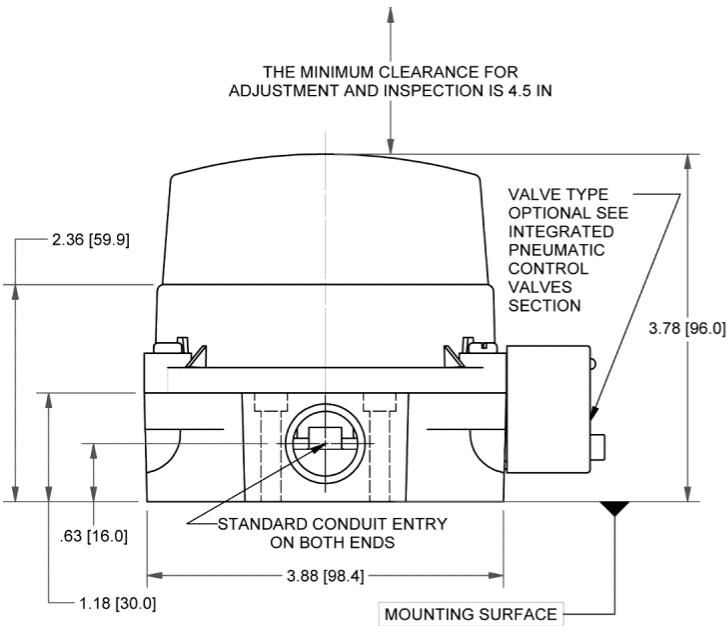

MATERIALS OF CONSTRUCTION	
Enclosure	Lexan 123R UV F1 Rated
Fasteners	304 Stainless Steel standard 316 Stainless Steel optional
Shaft	304 Stainless Steel standard 316 Stainless Steel optional
Indicator Dome	Lexan 123R UV F1 Rated
Seals	Nitrile/EPDM/Silicone (Other materials available upon request)

Fastener Torque Specifications	
Enclosure Housing Bolts	224 in-oz [1,582 mN·m] +/- 10%
Indicator Dome Screws	200 in-oz [141 mN·m]
Mounting Holes	4 ft-lbs [5.4 N·m] +/- 10%

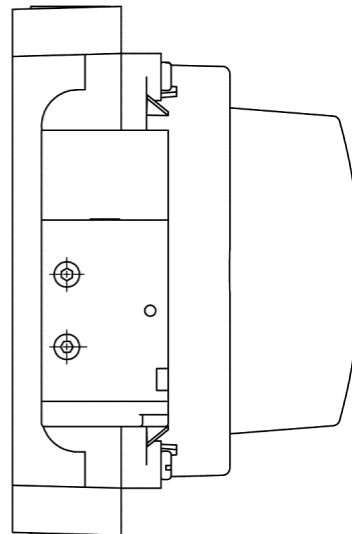
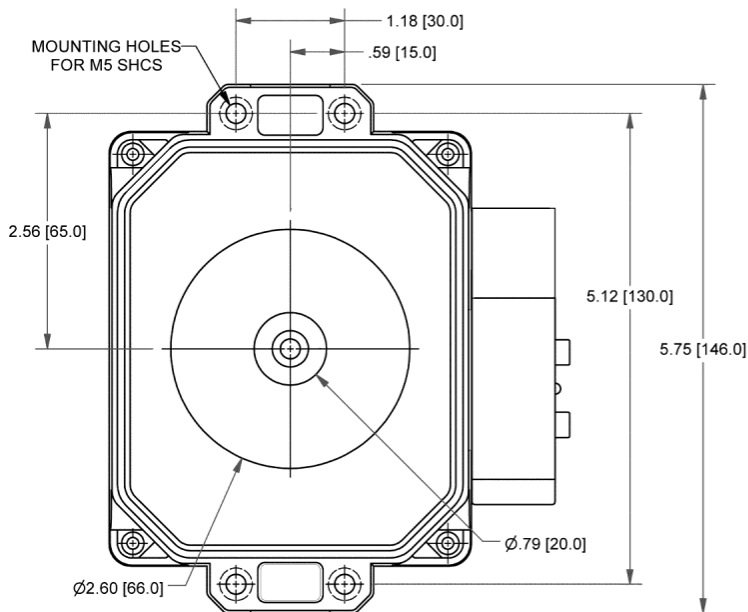

Dimensions and Materials: TopWorx™ TVF (Domed Lid)

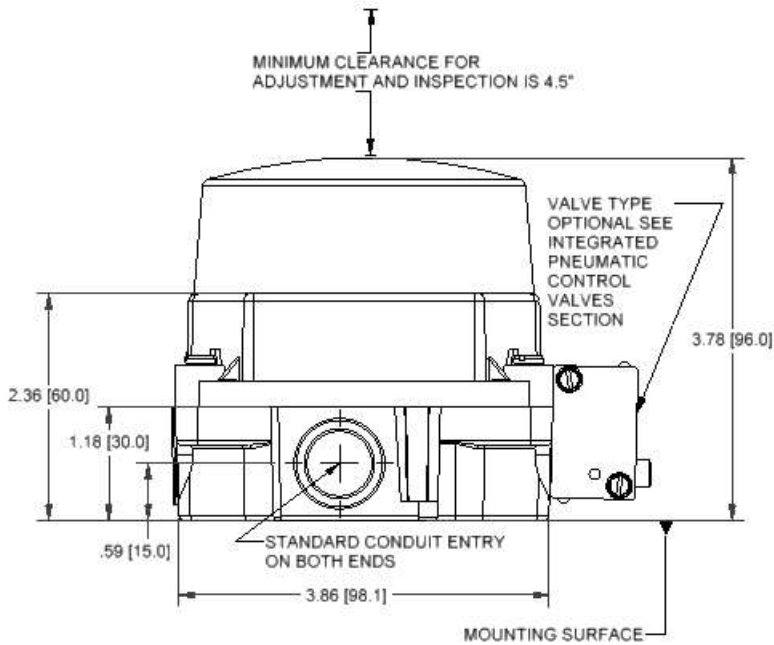

MATERIALS OF CONSTRUCTION	
Enclosure	Cast A360 aluminum with dichromate conversion coating inside & out, epoxy coated exterior rated for 1,000 hrs salt spray per ASTM B117
Fasteners	304 Stainless Steel standard 316 Stainless Steel optional
Shaft	304 Stainless Steel standard 316 Stainless Steel optional
Shaft Bushing	ASTM C83600 Bronze
Indicator Dome	Lexan 123R, UVF1 rated
Seals	Silicone

Maximum Fastener Torque Specifications	
Enclosure Housing Bolts	8 ft-lbs [10.8 N·m]
Indicator Dome Screws	200 in-oz [141 mN·m]
Bottom Mounting Holes	10 ft-lbs [13.6 N·m]

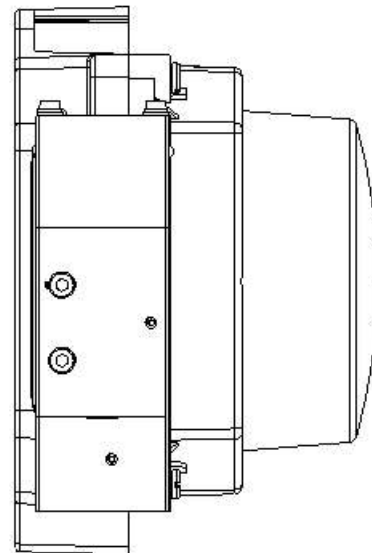
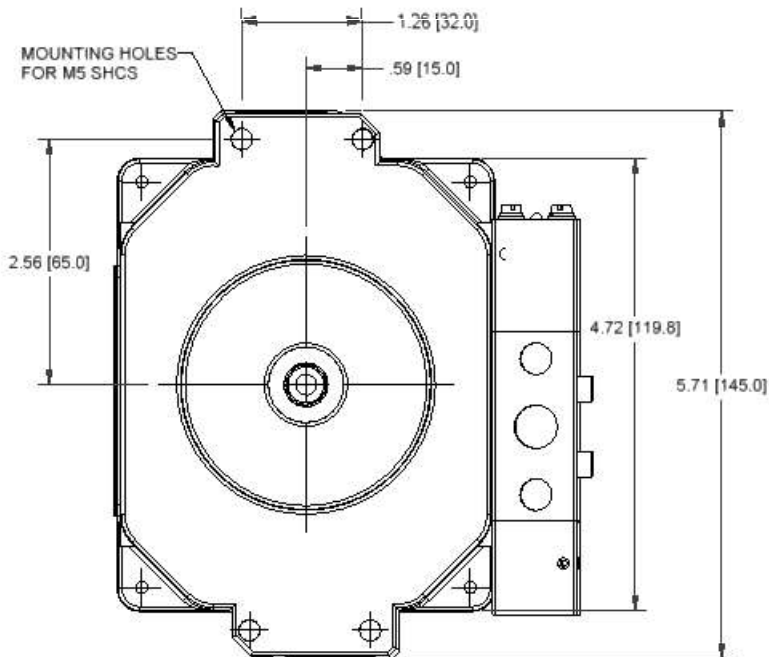

Dimensions and Materials: TopWorx™ TVL (Domed Lid)

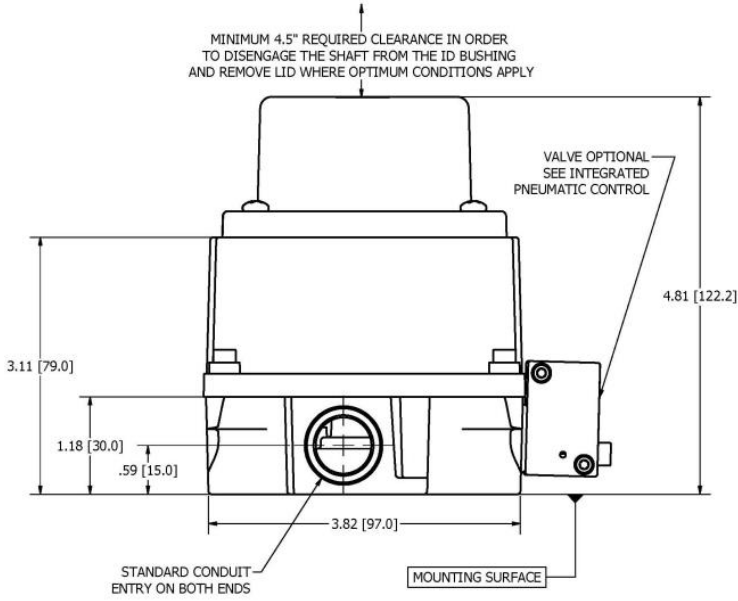

MATERIALS OF CONSTRUCTION	
Enclosure	Cast A360 aluminum with dichromate conversion coating inside & out, epoxy coated exterior rated for 1,000 hrs salt spray per ASTM B117
Fasteners	304 Stainless Steel standard 316 Stainless Steel optional
Shaft	304 Stainless Steel standard 316 Stainless Steel optional
Shaft Bushing	ASTM C83600 Bronze
Indicator Dome	Lexan 123R, UVF1 rated
Seals	Silicone

Maximum Fastener Torque Specifications	
Enclosure Housing Bolts	8 ft-lbs [10.8 N·m]
Indicator Dome Screws	200 in-oz [141 mN·m]
Bottom Mounting Holes	10 ft-lbs [13.6 N·m]

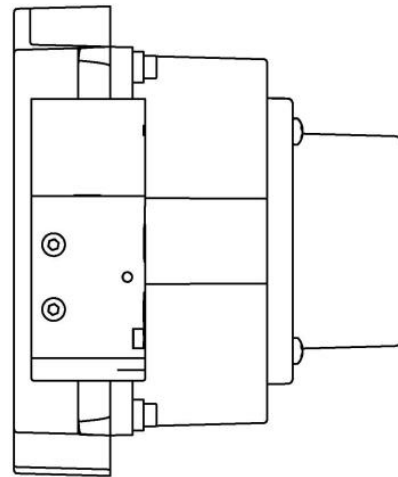
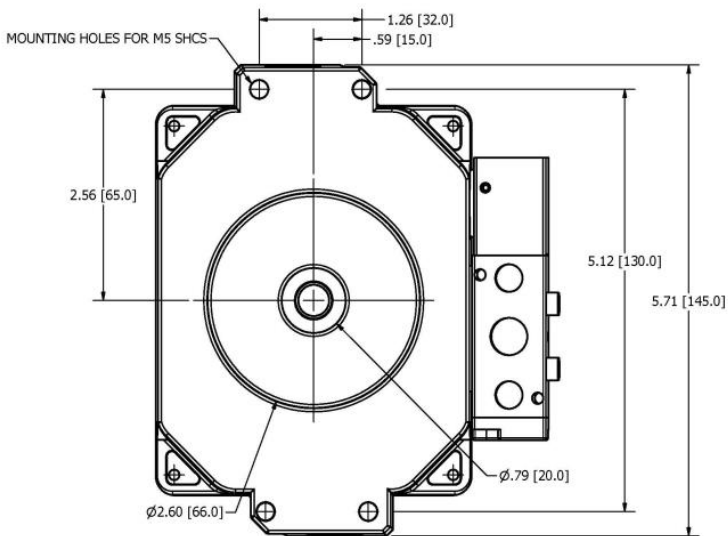

Dimensions and Materials: TopWorx™ TVH (Domed Lid)

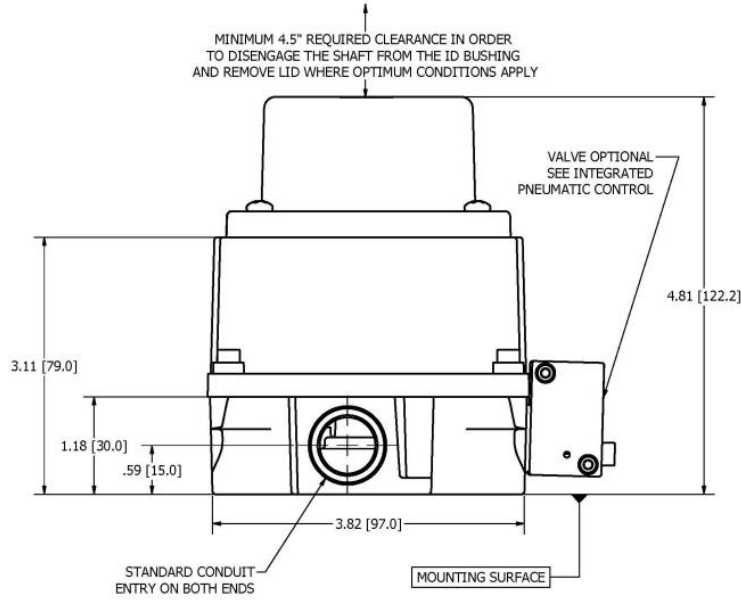

MATERIALS OF CONSTRUCTION	
Enclosure	Stainless Steel, 316
Fasteners	304 Stainless Steel standard 316 Stainless Steel optional
Shaft	304 Stainless Steel standard 316 Stainless Steel optional
Shaft Bushing	ASTM C83600 Bronze
Indicator Dome	Lexan 123R, UVF1 rated
Seals	Silicone

Maximum Fastener Torque Specifications	
Enclosure Housing Bolts	8 ft-lbs [10.8 N·m]
Indicator Dome Screws	200 in-oz [141 mN·m]
Bottom Mounting Holes	10 ft-lbs [13.6 N·m]

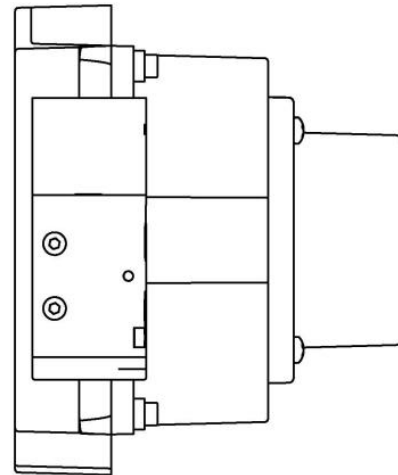
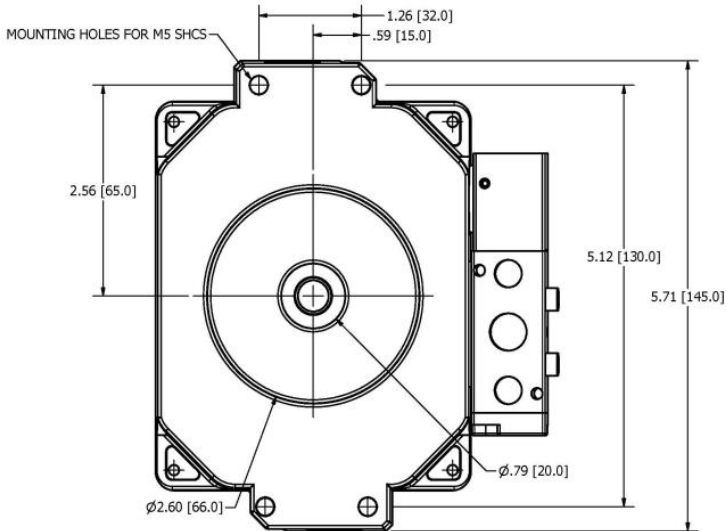

Dimensions and Materials: TopWorx™ TVL (Flat Lid)

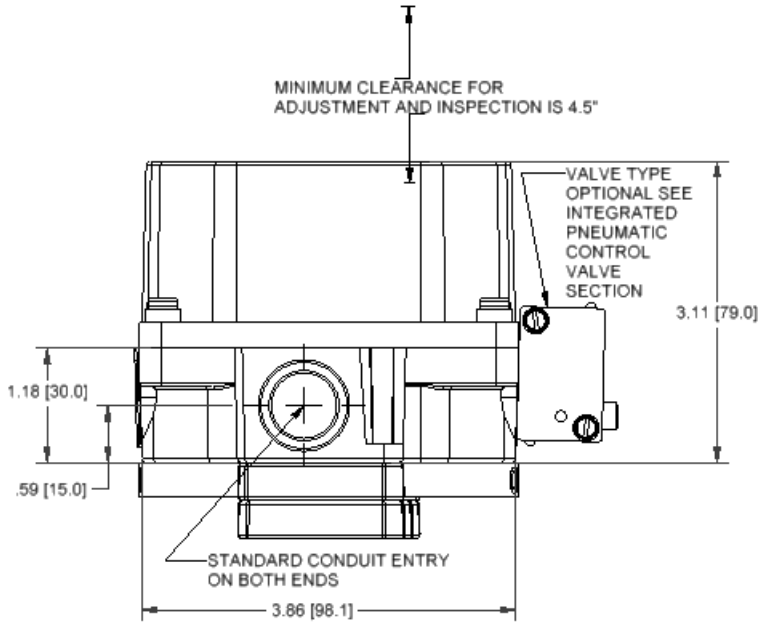

MATERIALS OF CONSTRUCTION	
Enclosure	Cast A360 aluminum with dichromate conversion coating inside & out, epoxy coated exterior rated for 1,000 hrs salt spray per ASTM B117
Fasteners	304 Stainless Steel standard 316 Stainless Steel optional
Shaft	304 Stainless Steel standard 316 Stainless Steel optional
Shaft Bushing	ASTM C83600 Bronze
Indicator Dome	Lexan 123R, UVF1 rated
Seals	Silicone

Maximum Fastener Torque Specifications	
Enclosure Housing Bolts	8 ft-lbs [10.8 N·m]
Indicator Dome Screws	200 in-oz [141 mN·m]
Bottom Mounting Holes	10 ft-lbs [13.6 N·m]

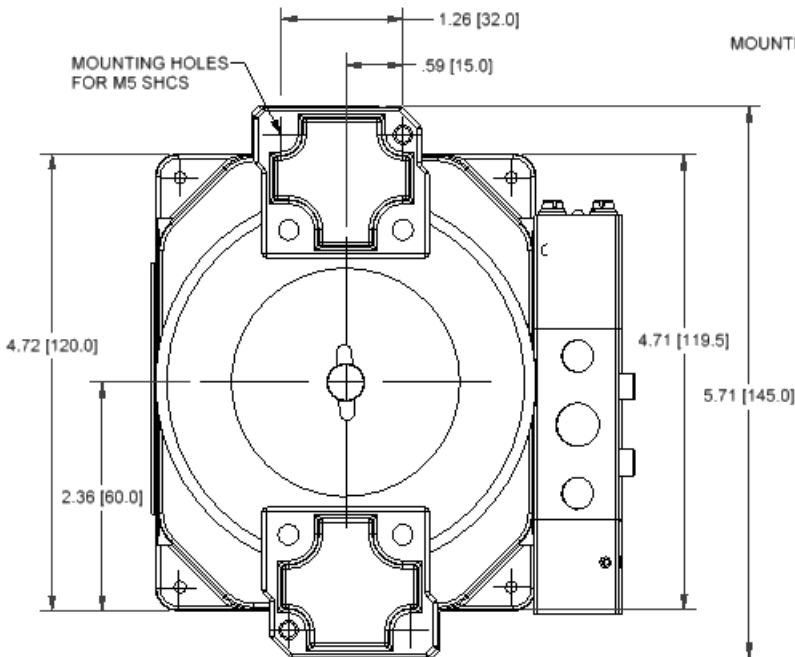

Dimensions and Materials: TopWorx™ TVH (Flat Lid)

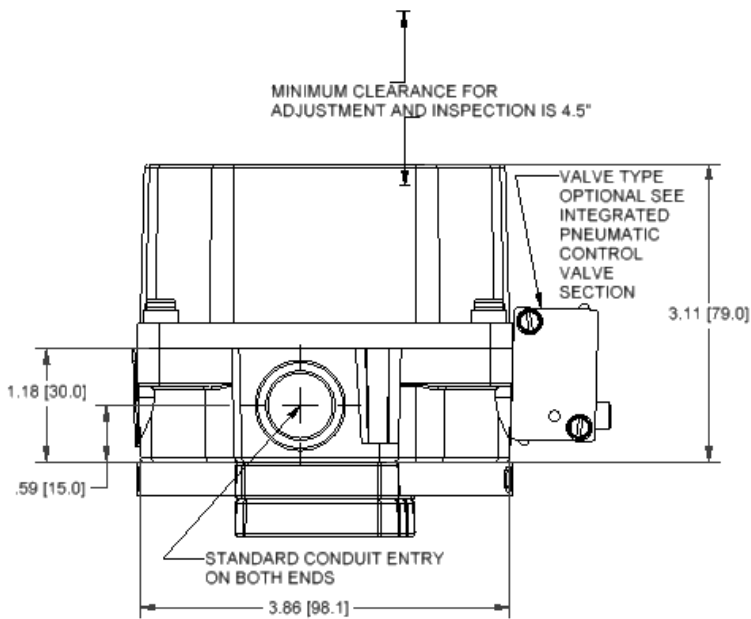

MATERIALS OF CONSTRUCTION	
Enclosure	Cast A360 aluminum with dichromate conversion coating inside & out, epoxy coated exterior rated for 1,000 hrs salt spray per ASTM B117
Fasteners	304 Stainless Steel standard 316 Stainless Steel optional
Shaft	304 Stainless Steel standard 316 Stainless Steel optional
Shaft Bushing	ASTM C83600 Bronze
Indicator Dome	Lexan 123R, UVF1 rated
Seals	Silicone

Maximum Fastener Torque Specifications	
Enclosure Housing Bolts	8 ft-lbs [10.8 N-m]
Indicator Dome Screws	200 in-oz [141 mN-m]
Bottom Mounting Holes	10 ft-lbs [13.6 N-m]

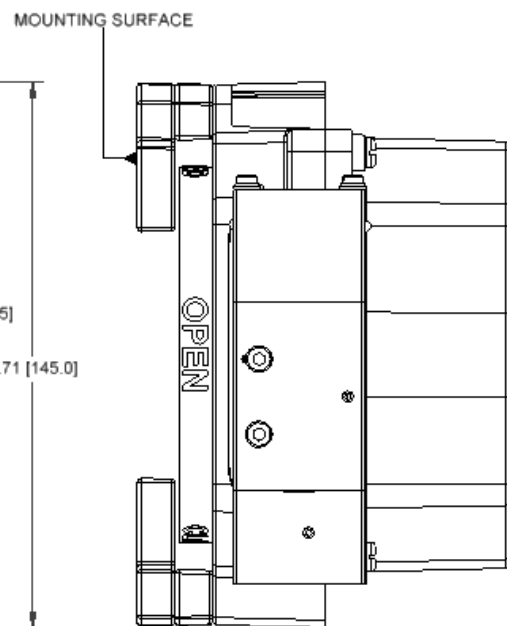
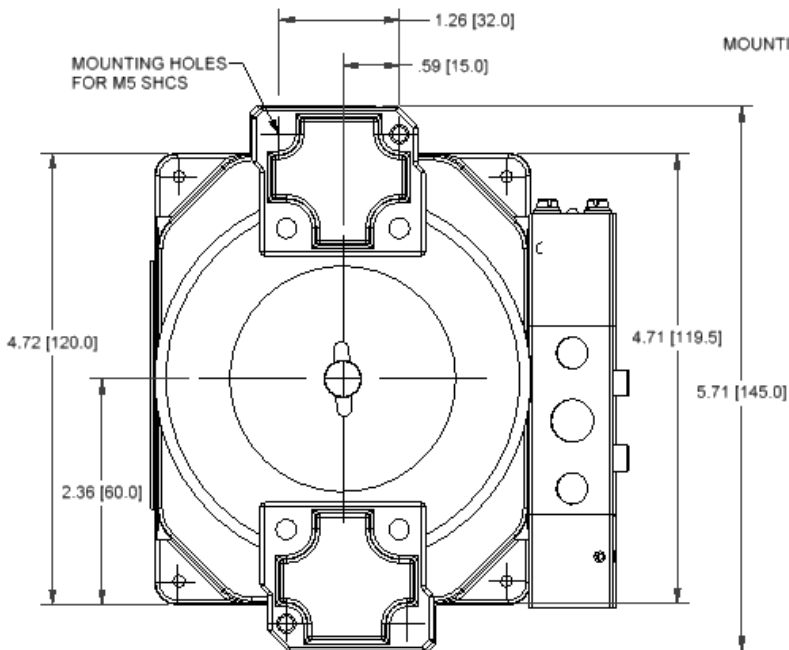

Dimensions and Materials: Shaft Detail

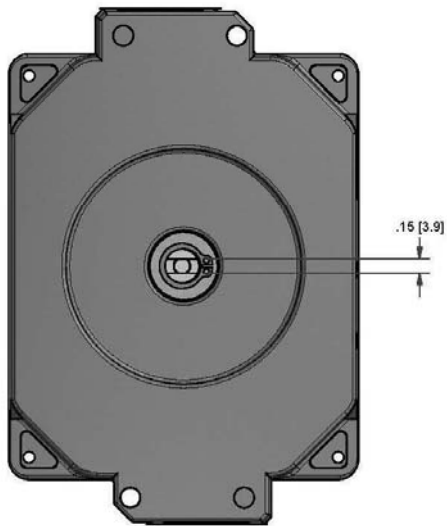
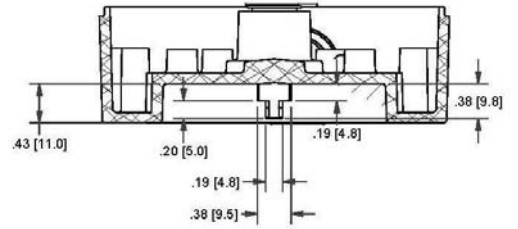
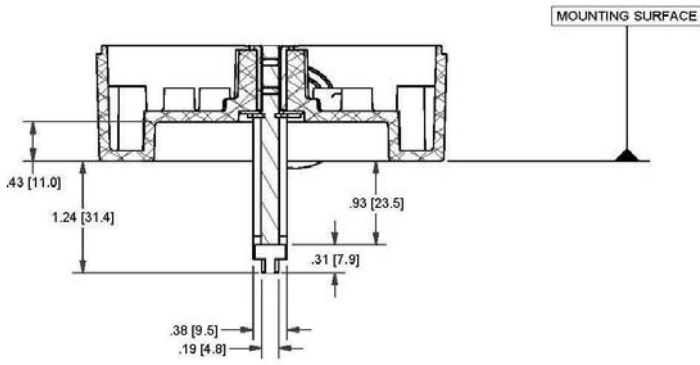

Sensors: Basic Function

Each T-Series unit is equipped with 2 or 4 adjustable targets with a usable range between 90° and 45°. For normal acting applications, the targets are color coded red for closed and green for open. The color code would be reversed for reverse acting units. After installing the unit on the actuator or valve assembly, the targets must be set.

Normal acting

1. Rotate the valve full CW to the closed position.
2. Twist the red target or press and move the metal target CW or CCW as required to engage the switch (refer to the specific switch section for testing and confirmation information about your switch type).
3. Rotate the valve full CCW to the open position.
4. Twist the green target or press and move the metal target CW or CCW as required to engage the switch (refer to the specific switch section for testing and confirmation information about your switch type).

Reverse acting

1. Rotate the valve full CW to the open position.
2. Twist the red target or press and move the metal target CW or CCW as required to engage the switch (refer to the specific switch section for testing and confirmation information about your switch type).
3. Rotate the valve full CCW to the closed position.
4. Twist the green target or press and move the metal target CW or CCW as required to engage the switch (refer to the specific switch section for testing and confirmation information about your switch type).

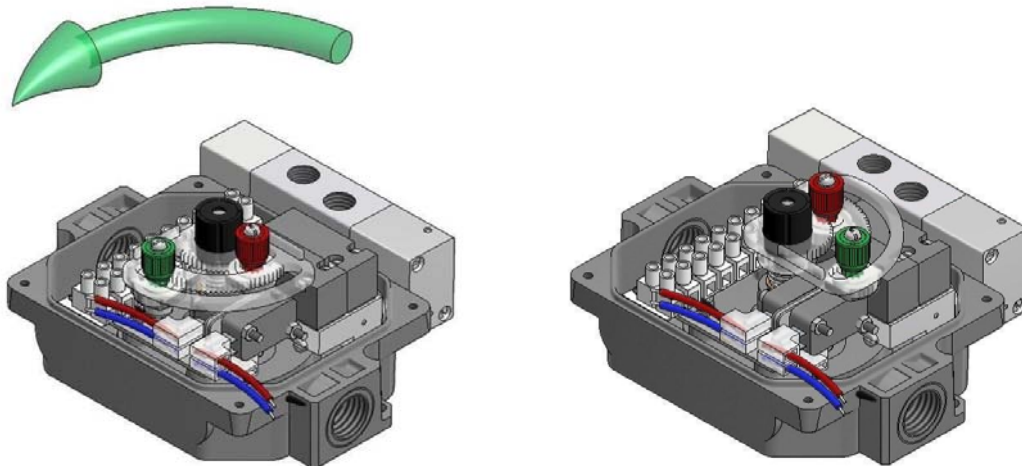

Setting Switches

Unlock green and red targets. Stroke the actuator open and closed to ensure there is no obstruction in its stroke. Once actuator is at the desired position, twist the knob on the cam or press and move the metal target until the switch is made and lock the appropriate target. The red knob is for the closed position and the green is for the open position (normal acting).

Warning: Strikers are spring-loaded and may eject forcefully upon disassembly. Use caution when disassembling.

For switching angle under 45° (for red and green twist knobs only):

When the switchbox is mounted to a linear actuator, or when the actuator strokes less than 45°, we recommend the following:

1. Remove shaft from switchbox by removing the circlip underneath the switchbox
2. Remove the circlip underneath the cam if equipped, then push the cam down the shaft by 3-4mm and turn it 90°
3. Push the cam back up, you will see the flats fit snugly between the locating lugs inside the hub
4. Replace the circlip
5. Remove the closed switch from the bracket and install it on the inside of the bracket next to the open switch

To re-assemble:

1. Replace the screws with M3 X 25mm long screws (insert through both switches and bracket and fasten with the nut on the inside closest to the switchbox bearing).

To re-assemble (continued):

2. Remove the Closed striker assembly (red) by removing the circlip or screw on top, and install it on the inner rack
3. Unlock and twist the green striker to the other end of the cam's rack. (The red striker assembly should be unlocked and twisted to the other end of the inner rack.)
4. Re-install the shaft in the switchbox and fit the s/s washer and circlip to the underside of the switchbox
5. The switches can now be set anywhere between 0° & 45°



**LOCKED
(aligned)**



**UN-LOCKED
(not aligned)**

For switching angle up to 180° (for red and green twist knobs only)

1. Remove shaft from switchbox by removing the circlip underneath the switchbox
2. Remove the open switch from the bracket and install it on the inside of the bracket
3. Remove the Open striker assembly (green) by removing the circlip or screw on top, and install it on the inner rack next to the red striker assembly
4. Re-install the shaft in the switchbox and fit the s/s washer and circlip to the underside of the switchbox
5. The open switch can now be set anywhere between 90° & 180°

Target assembly for 90° rotation

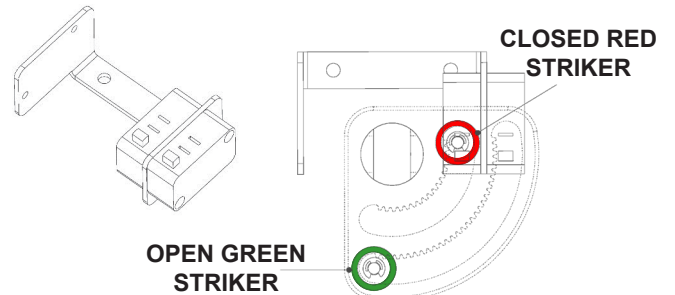
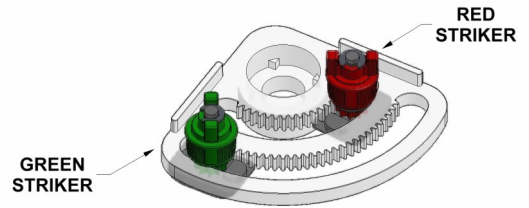

*CAM SHOWN IN CLOSED POSITION

GO™ Switch Option

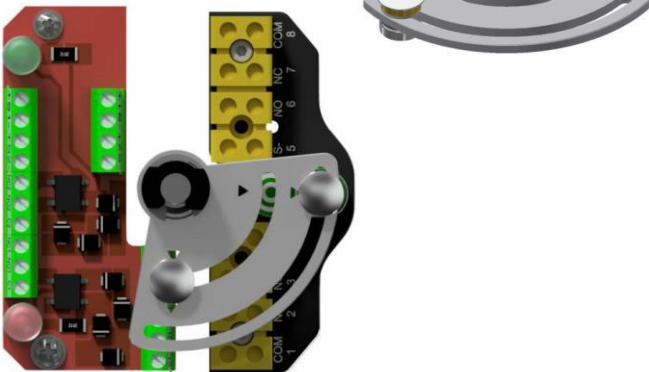

4-Switch Target Assembly

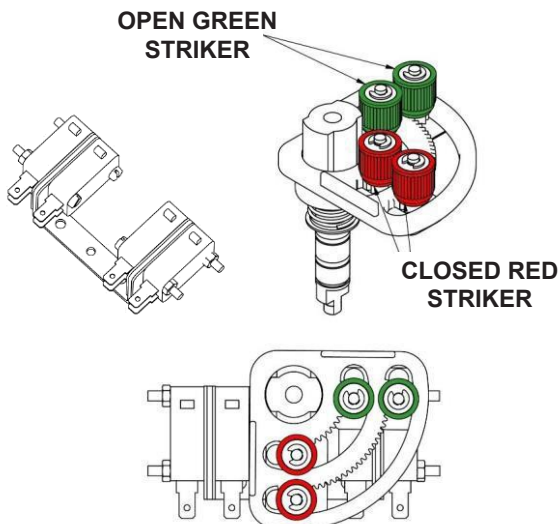

Target assembly for 180° rotation

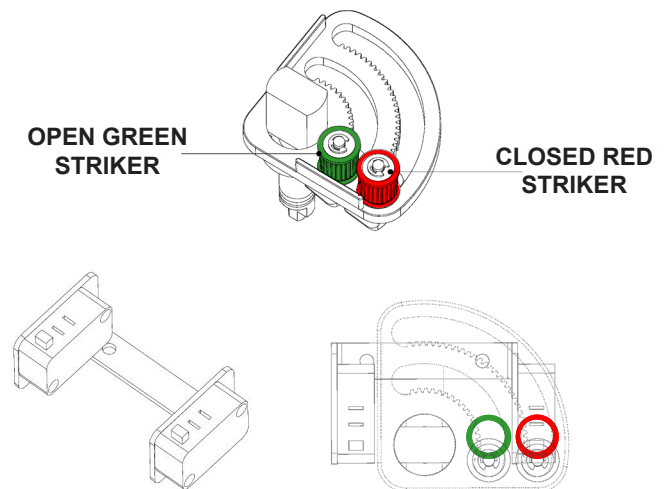

Switch Option D2/D4, S2/S4: GO™ Switches

When installing units with D or S switches, a standard voltage ohm meter may be used to set the targets by looking for continuity between the N/O and COMMON wires.

Wiring Diagrams

SW 1 & 2

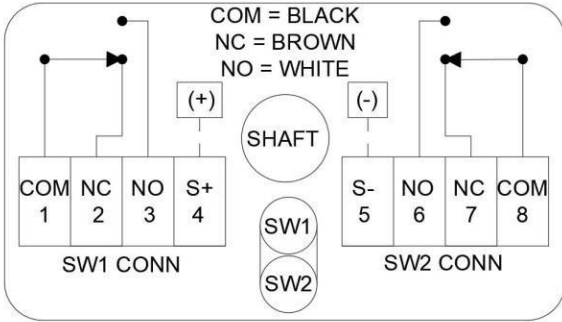

SW 3 & 4

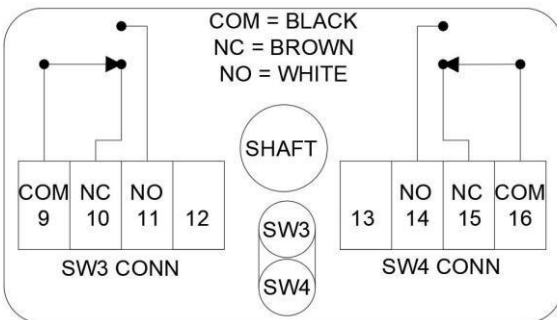

D2/S2 Diagram

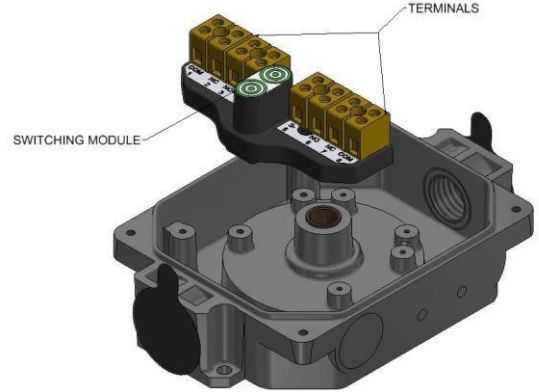

D4/S4 Diagram

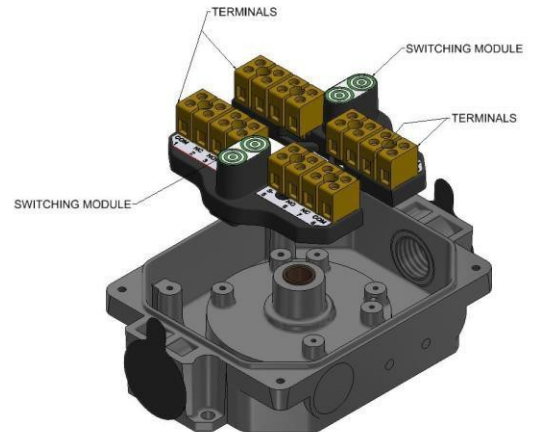

MATERIALS OF CONSTRUCTION	
OPTION D	
Switch Type	GO™ Switch
Sealed	Sealed Device
Form	SPDT
Electrical Rating	1A@24VDC
OPTION S	
Switch Type	GO™ Switch
Sealed	Hermetically Sealed
Form	SPDT
Electrical Rating	3mA to 3A @ 24VDC or 3A @ 120VAC
Terminal Wire Size (D and S)	.2• 2.5mm ² 24•14A WG

Specific Conditions of Use:

When the supply to the switches do not exceed 60VAC/85VDC, the supply shall be protected such that transients are limited to a maximum of 119V.

If the supply is above 60VAC/85VDC, but not exceeding 120VAC, the supply shall be protected such that the transients are limited to maximum of 138V.

Switch Option M2/M4: SPDT Mechanical Switches

When installing units with M switches, a standard voltage ohm meter may be used to set the target cams by looking for continuity between the N/O and COMMON wires.

Wiring Diagrams

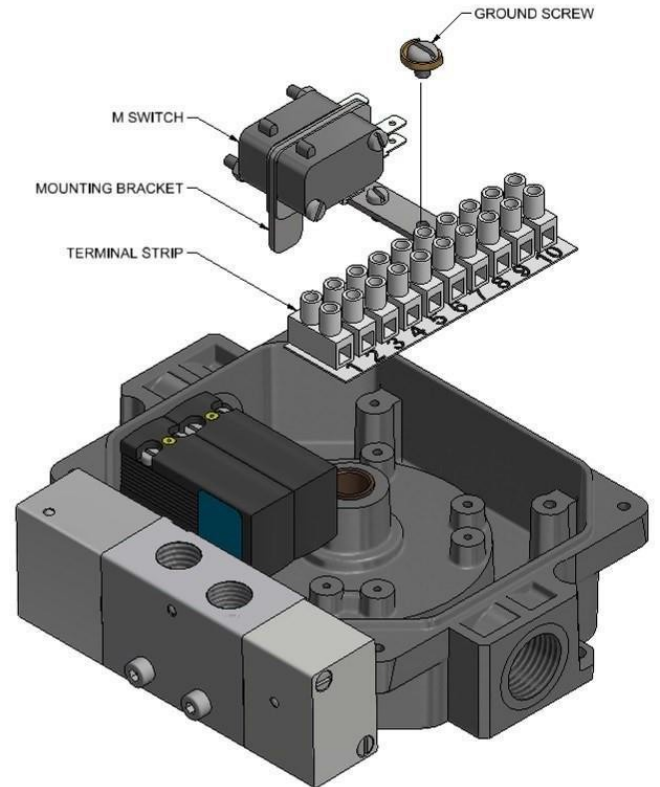
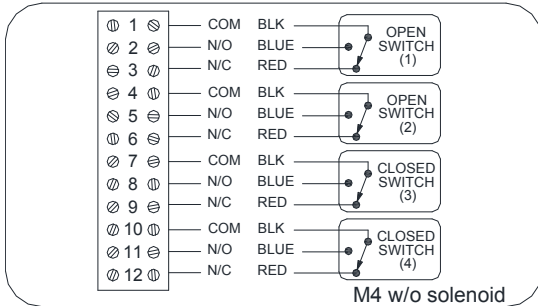
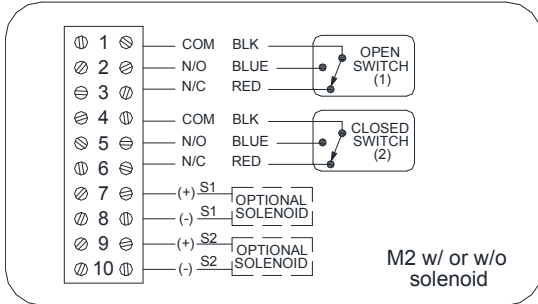

MATERIALS OF CONSTRUCTION	
OPTION M	
Switch Type	Mechanical
Sealed	No
Form	SPDT
Terminal Maximum wire size	4mm squared (14AWG)
Electrical Rating	10A@125VAC or 250VAC
Conforming to Standards	UL: 1054
Contact Resistance	15mΩmax. (initial)
Insulation Resistance	100MΩmin. (at 500V DC)
OPTION K	
Switch Type	Mechanical
Sealed	No
Form	SPDT
Terminal Maximum wire size	4mm squared (14AWG)
Electrical Rating	0.1A@125VAC MAX
Conforming to Standards	UL: 1054

Switch Option T2: DPDT Mechanical Switches

When installing units with T switches, a standard voltage ohm meter may be used to set the target cams by looking for continuity between the N/O and COMMON wires.

Wiring Diagram

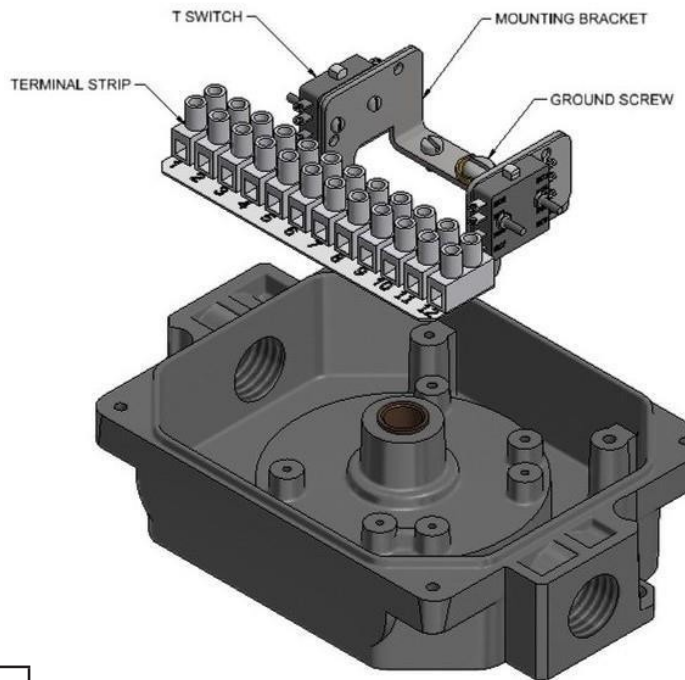
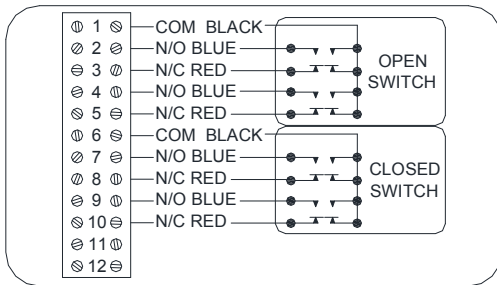

PRODUCT SPECIFICATIONS	
Switch Type	Mechanical
Sealed	No
Form	DPDT
Terminal Maximum wire size	4mm ² (14AWG)
Electrical Rating	8A 125V AC or 250V AC
Conforming to Standards	UL recognized and CSA certified, meets MIL-S-8805
Contact	Silver

Switch Options R2/R4: SPDT Reed Switches

When installing units with R switches, a standard voltage ohm meter may be used to set the target cams by looking for continuity between the N/O and COMMON wires.

Wiring Diagram

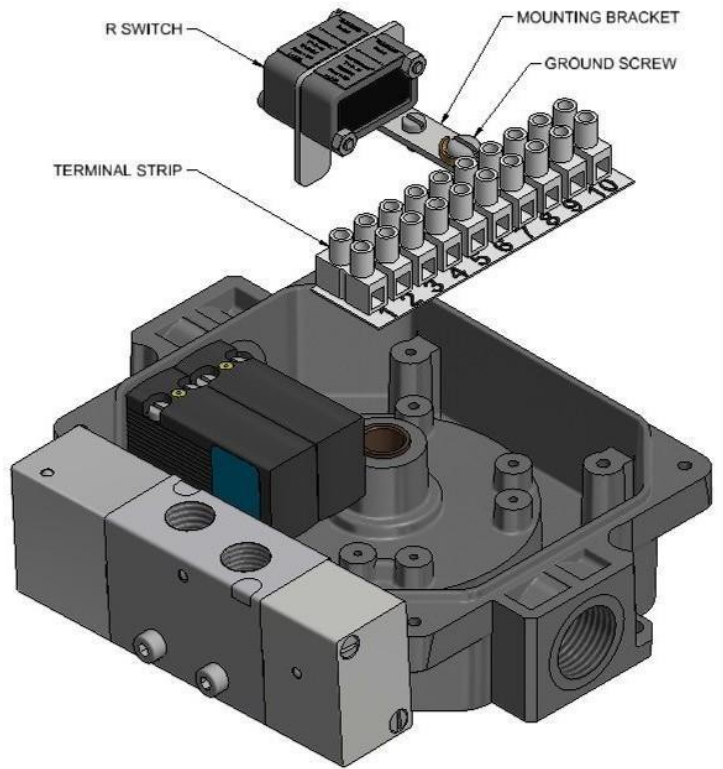
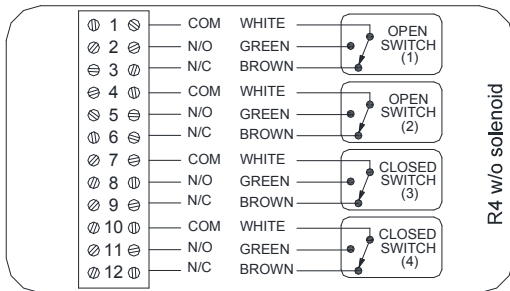
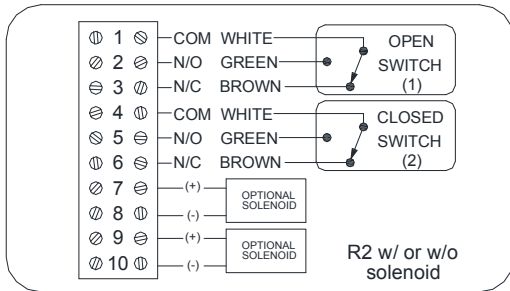

PRODUCT SPECIFICATIONS	
OPTION P	
Switching Voltage	DC/AC 120V Max
Switching Current	3 Amp Max
Power Rating	3 - 100 Watt
Contact Material	Tungsten
Form	SPDT
OPTION R	
Switching Voltage	DC/AC 30V Max
Carry Current	0.5 Amp Max
Switching Current	0.2 Amp Max
Power Rating	3 Watt
Contact Material	Rhodium
Form	SPDT
Terminal Maximum Wire Size	4mm ² (14AWG)

Switch Options P2: SPDT Reed Switches

When installing units with P switches, a standard voltage ohm meter may be used to set the target cams by looking for continuity between the N/O and COMMON wires.

Wiring Diagram

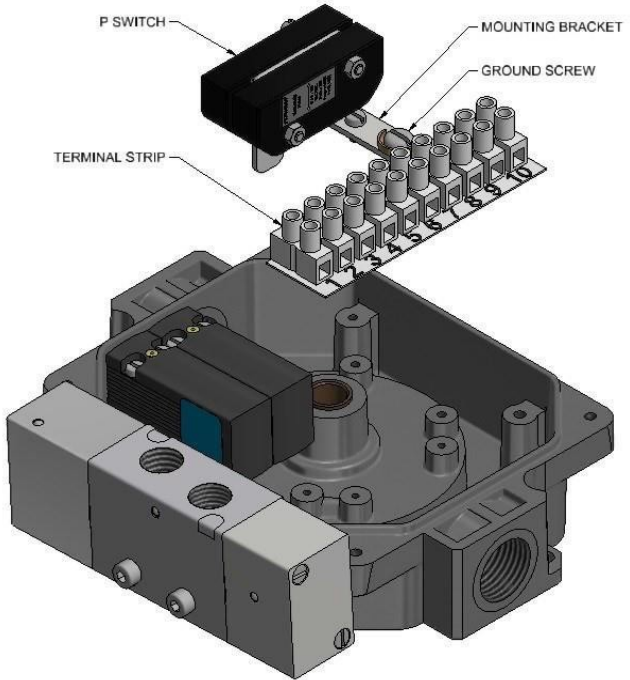
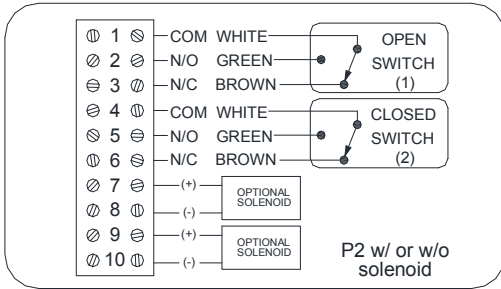

PRODUCT SPECIFICATIONS	
OPTION P	
Switching Voltage	DC/AC 120V Max
Switching Current	3 Amp Max
Power Rating	3 - 100 Watt
Contact Material	Tungsten
Form	SPDT
OPTION R	
Switching Voltage	DC/AC 30V Max
Carry Current	0.5 Amp Max
Switching Current	0.2 Amp Max
Power Rating	3 Watt
Contact Material	Rhodium
Form	SPDT
Terminal Maximum Wire Size	4mm ² (14AWG)

Switch Option DS/RS/PS/MS/KS: TV-LED with SPDT Proximity Switches

The TV-LED indicator is designed to handle up to two SPDT proximity switches with LED indication and two pilot valve solenoids. Only the normally open contact of the SPDT proximity switch is utilized in driving the LED circuitry, while the normally closed side may be utilized as a standard dry contact. Terminals S1+, S1-, S2+, and S2- act as a direct feedthrough termination block. Typically, these terminals are utilized to optionally drive either internal or external pilot valve solenoids. However, they may also be used in other applications requiring a feedthrough termination block.

Wiring Diagram

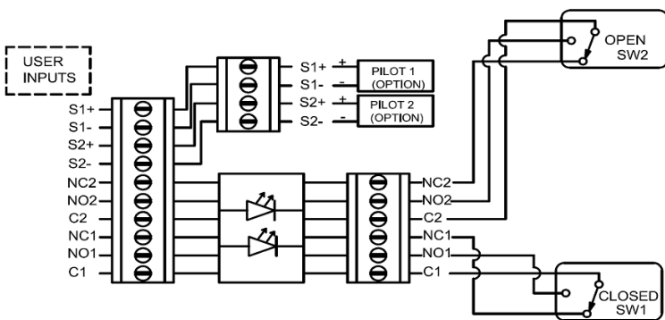

MECHANICAL SWITCH

MOUNTING BRACKET

LED MODULE

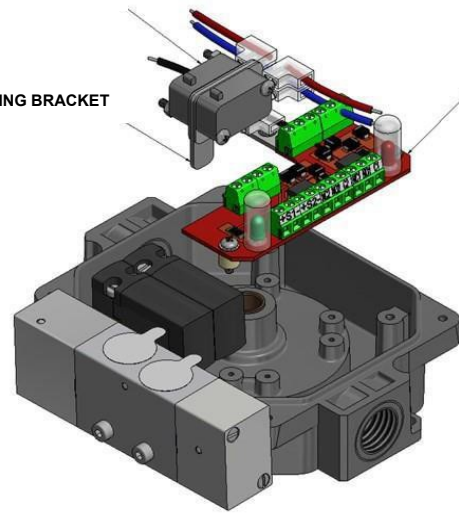

PRODUCT SPECIFICATIONS	
Option DS	
Maximum Operating Voltage	120VAC/24VDC
Maximum Load Current (IL)	250mA
Minimum Recommended Load Current	10mA
Maximum Voltage Drop (IL)	5V
Option MS/KS	
Maximum Operating Voltage	120VAC
Maximum Load Current (IL)	250mA
Minimum Recommended Load Current	10mA
Maximum Voltage Drop (IL)	5V
Option PS	
Maximum Operating Voltage	120VAC
Maximum Load Current (IL)	250mA
Minimum Recommended Load Current	10mA
Maximum Voltage Drop (IL)	5V
Option RS	
Maximum Operating Voltage	120VAC
Maximum Load Current (IL)	250mA
Minimum Recommended Load Current	10mA
Maximum Voltage Drop (IL)	5V
Terminal Maximum Wire Size	0.14-1.5mm ² (14AWG) 26-16AWG

LED Wiring Diagram

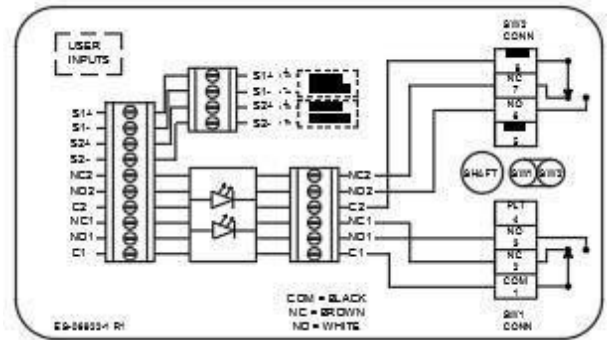

Switch Option E2/E4: Inductive NAMUR Sensors

Basic inductive proximity sensors

- 2mm sensing range
- Flush mountable
- NAMUR output
- Intrinsically safe when connected to an approved switch isolator

Wiring Diagram: Switch Option E

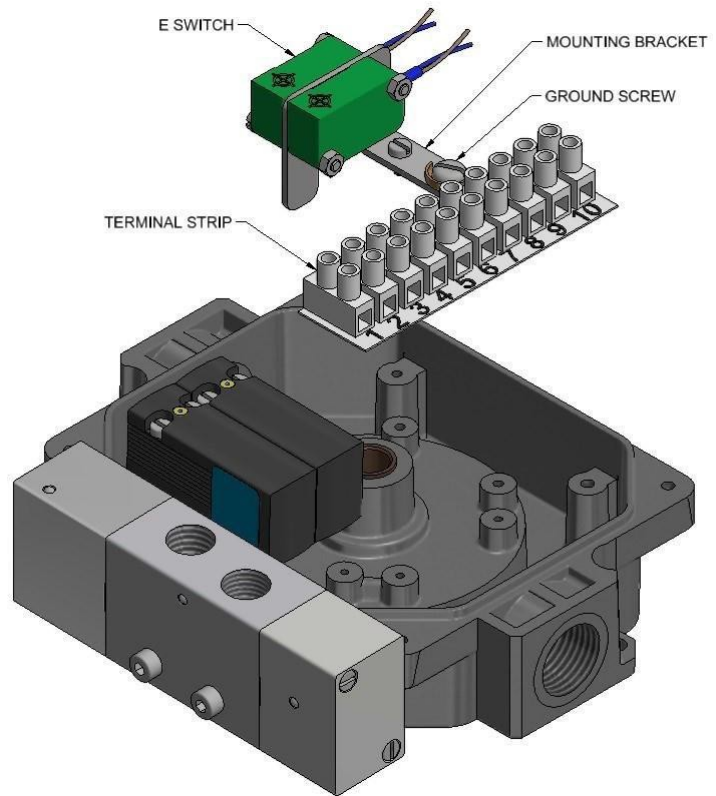
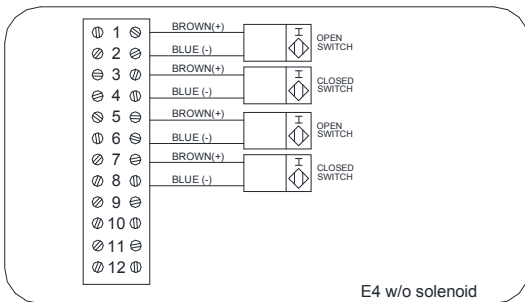
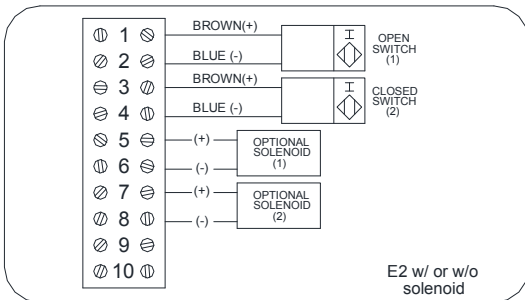

PRODUCT SPECIFICATIONS				
General Specifications			Standard Conformity	
Switching element function		NAMUR NC	EMC in accordance with	IEC / EN 60947-5-2:2004
Rated operating distance	sn	2 mm	Standards	DIN EN 60947-5-6 (NAMUR)
Installation		em beddable	Ambient Conditions	
Output polarity		NAMUR	Ambient temperature	-25 ... 100°C (248 ... 373 K)
Assured operating distance	sa	0 ... 1.62 mm	Mechanical Specifications	
Reduction factor rAl		0.25	Connection type Core cross-section	
Reduction factor rCu		0.2	Housing material	
Reduction factor rV2A		0.7	Sensing face	
Terminal Maximum Wire Size		4mm ² (14AWG)	Protection degree	
Nominal Ratings			General Information	
Nominal voltage	U _o	8 V	Use in the hazardous area	see instruction manuals
Switching frequency	f	0 ... 1000 Hz	Category	1G; 2G; 1D
Hysteresis	H	typ. %		
Current consumption				
Measuring plate not detected		≥3 mA		
Measuring plate detected		≤1 mA		



When installing TopWorx™ products with P&F sensors, we suggest using a commercially available switch tester like P&F part number: ST0-03 switch tester.

Switch Option 42/44 or 52/54: Inductive Sensors

42 Wiring Diagram

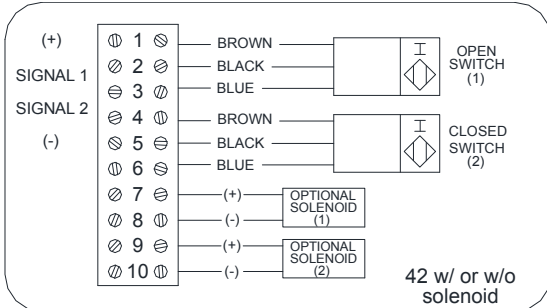

52 Wiring Diagram

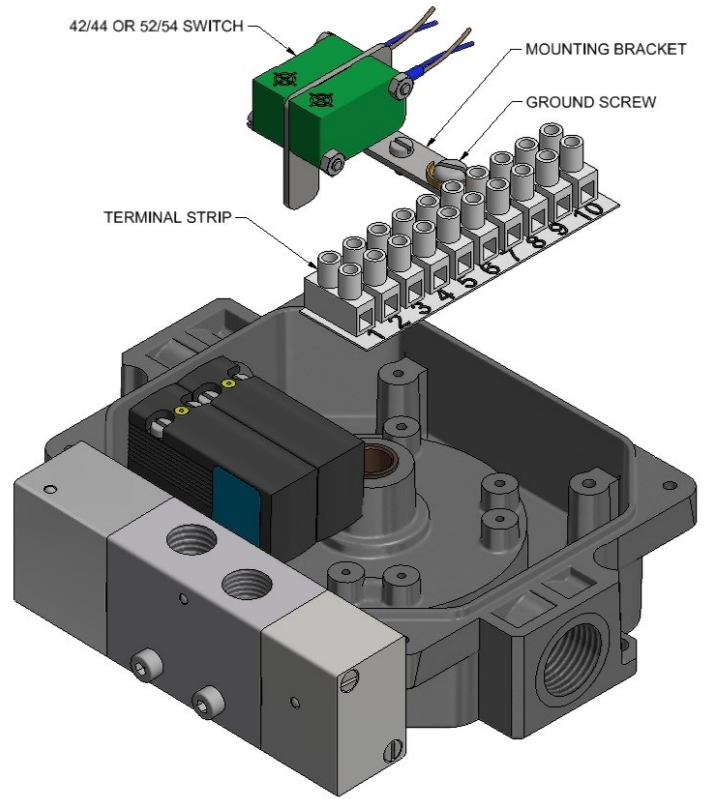
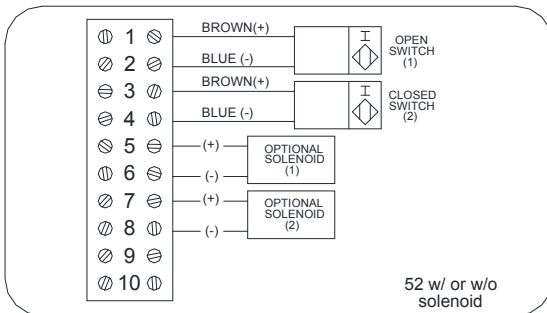

SWITCH OPTION 42	
Supply Voltage	10-30 VDC
Load Current (IL)	100 mA max.
Leakage Current (OFFSTATE)	0.05 mA typ., 0.1 µA at 25°C
Output	PNP normally open
Voltage Drop AT IL (MAX.)	≤ 3 V
Hysteresis	—
Short Circuit and Overload Protection	Yes
Reverse Polarity	Yes
Face Material	PBT
Standards	EN 60947-5-2
Environmental Protection	IP67
Ambient Temperature	-14 °F to +158 °F (-25.6 °C to +70 °C)
Terminal Maximum Wire Size	4mm ² (14AWG)

SWITCH OPTION 52	
Supply Voltage	5-60 VDC
Load Current (IL)	100 mA max.
Leakage Current (OFFSTATE)	0.05 mA typ., 0.1 µA at 25°C
Output	PNP normally open
Voltage Drop AT IL (MAX.)	≤ 5 VDC
Hysteresis	Typ. 0.2mm
Short Circuit and Overload Protection	No
Reverse Polarity	Yes
Face Material	Crastin
Standards	IEC / EN 60947-5-2:2004
Environmental Protection	IP67
Ambient Temperature	-14°F to +185°F (-25.6 °C to +85 °C)

Bus Option AM: ASi Protocol with Mechanical SPDT Switches

Wiring Diagram:

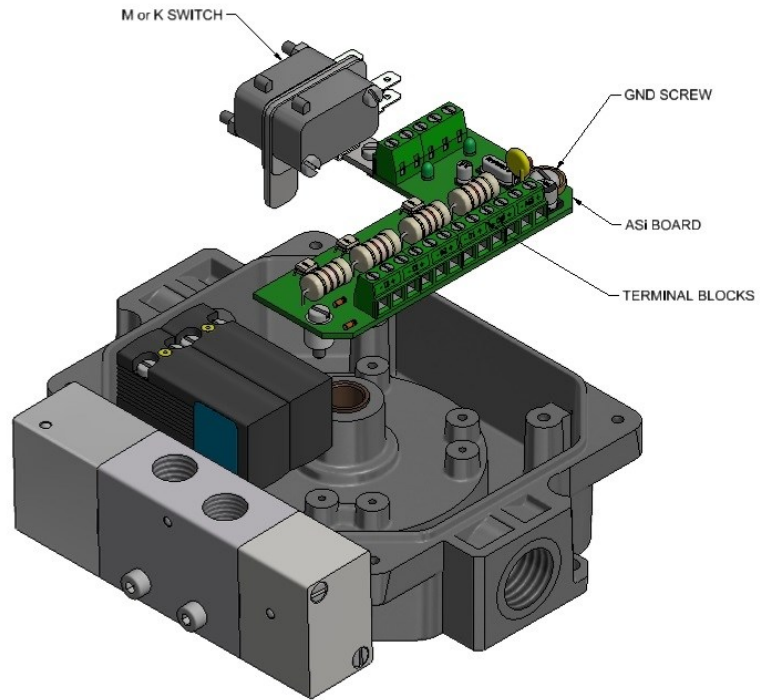
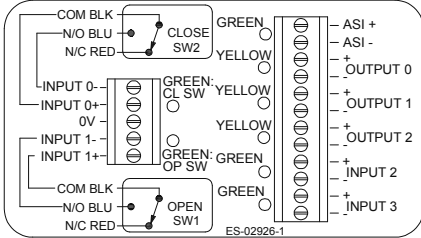

Bus Option AS: ASi Protocol with Reed Switches

Wiring Diagram:

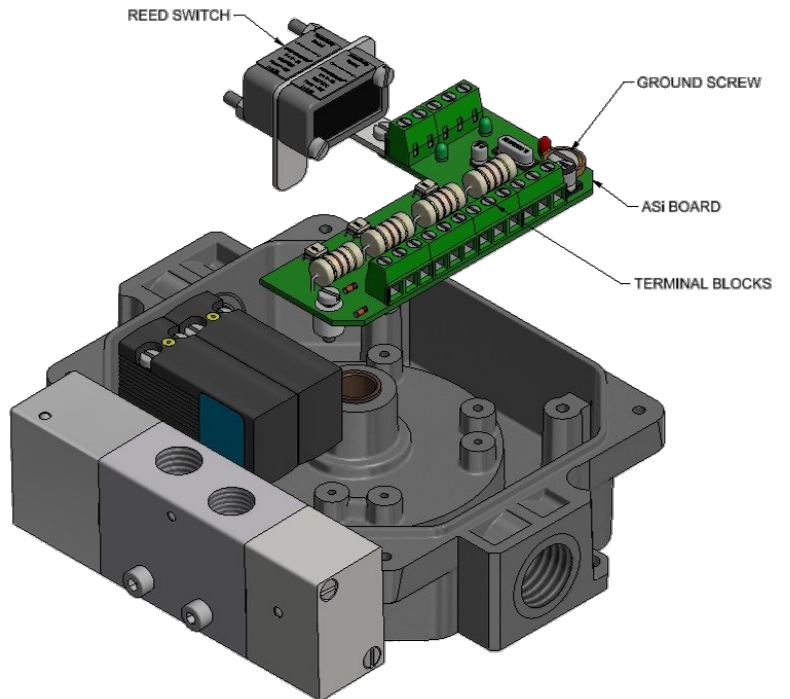
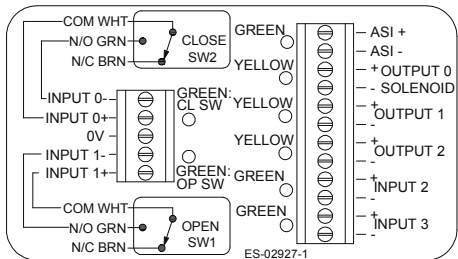

Bus Options AM/AS: ASI Protocol

Openness	800+ products, 150 Vendors
Type of Network	Sensor Bus
Physical Media	2-wire cable (flat or round)
Network Topology	Bus, Ring, Tree, Star
Maximum Devices	
v3.0	62 nodes (or 496 I/O points)
Maximum Devices	
Maximum Distance	100 meters
Maximum Distance with repeaters (max. of 2 repeaters can be used)	300 meters
Communication Methods	
Transmission Properties	5 mSec latency max. on fully loaded segment
Primary Usage	<ul style="list-style-type: none"> • Master/Slave with cyclic polling • Manchester Bit Encoding implemented via Alternating Pulse Modulation (APM)
Power & Communications on same pair	<ul style="list-style-type: none"> • Limited to 200 mA per device power consumption (29.5V DC to 31.6V DC) • Requires AS-i specific power supply on communications bus for de-coding
Device Power Supply	<ul style="list-style-type: none"> • Devices can be supplied from bus (<200 mA) • Additional power can be supplied by AS-i power bus cable having multiple power supplies (required for higher power outputs) • Supply shall be powered by a limited-voltage power supply
Wiring Types	
Round:	Normal 2 wire cable. #16AWG (1.5mm)
Flat:	2 wire flat AS-i cable (1.5mm conductors) Yellow for communications / Black for additional power
Grounding aspects	Ungrounded communications bus
Shielding	Unshielded wire
Terminators	No terminators required
Device Addressing	Automatic when connected one at a time to the segment or with Handheld Addressing Unit
Governing Body	ATO (AS-i Trade Organization)
Website	www.as-interface.com
Electromagnetic Compatibility	EN 61326-1:2006, EN 61000-4-2:1995 inc. A2:2001, EN 61000-4-3:2002, EN 61000-4-4:2004 inc. A1:2010, EN 61000-4-6:2009, EN 61000-4-8:1993 inc. A1:2001, EN 55011:2009 inc.

AS-i Bit Settings	Data bit	Bit	Function	Input	Output
		D0	Input I1 / Output O1	Closed limit Red	Solenoid switch 1
		D1	Input I2 / Output O2	Open limit Green	Solenoid switch 2
		D2	Input I3 / Output O3	N/A	Solenoid switch 3
		D3	Input 4	Fault Signal (optional)	N/A
	Parameter bit	Bit	Function	Configuration Code	
		P0	not used	Extended ID code 1	7
		P1	not used	IO Code	7
		P2	not used	Extended ID code 2	E
		P3	not used	Parameter	8
Watchdog	on	ID code	A		

Bus Option DM/DN: DeviceNet Protocol with Mechanical SPDT Switches

Wiring Diagram:

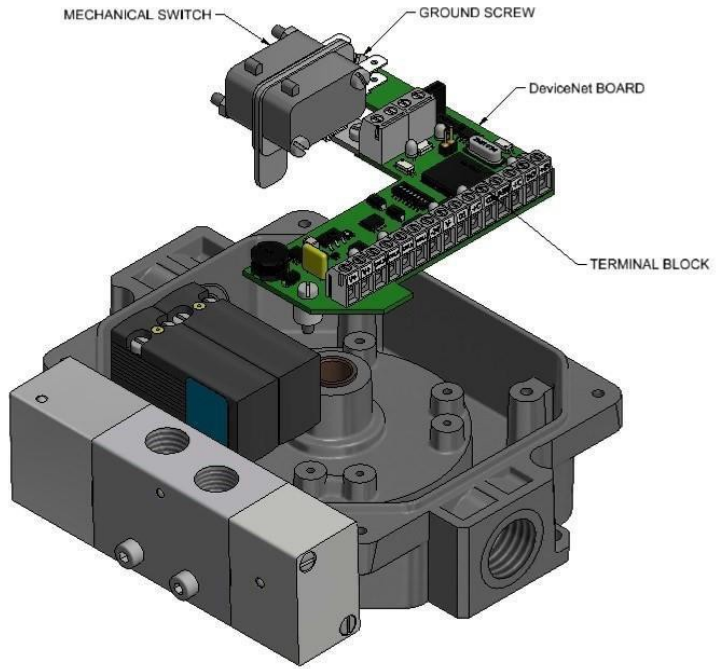
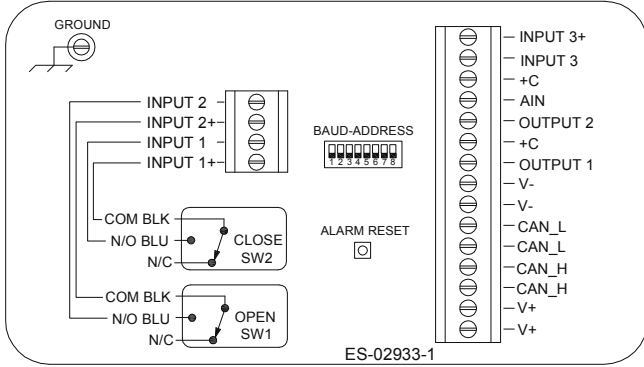

Bus Option DN: DeviceNet protocol with Reed Switches

Wiring Diagram:

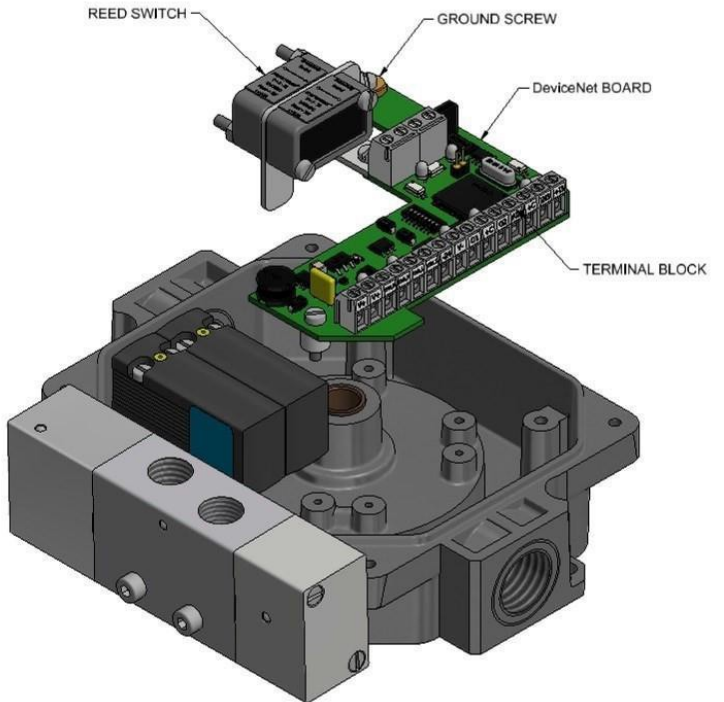
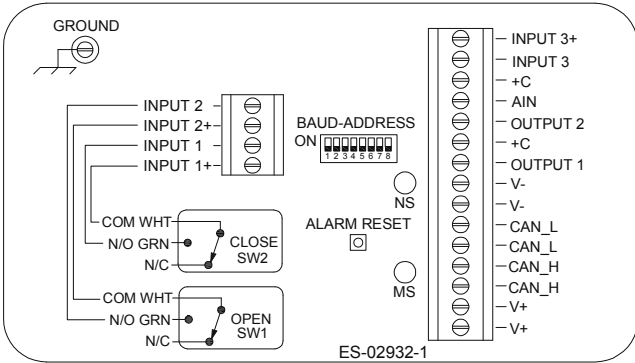

Bus Options DM/DN: DeviceNet Protocol (continued):

Description: Remote multiplexer, compatible with ODVA's DeviceNet protocol for discrete I/O. This is a product family which supports three (3) discrete inputs, two (2) discrete outputs, and 1 analog *10-bit* input.

DeviceNet Device Profile: General Purpose Discrete I/O, Class 7 with objects:
 - Identity (Class 1)
 - Message Router (Class 2)
 - DeviceNet (Class 3)
 - Assembly (Class 4) ----- 5 instances
 - Connection (Class 5)
 - Parameter (Class F_{hex}) ---- 10 instances
 - Valve (Class 6E_{hex})
 - Alarm (Class 6F_{hex}) ---- 5 instances
 - Alarm Group (Class 70_{hex}) ---- 2 instances

DeviceNet Conformance: Designed to conform to the ODVA DeviceNet Specification Volume I, Version 2.0 and Volume II, Version 2.0. Communications: Predefined Master/Slave Connection Set, Group 2 Only Server

DeviceNet I/O Protocols: Polled I/O
 Change-of-state (COS), Cyclic

I/O Electrical Specifications

Ratings	Min	Typical	Max	Units	Comments
Input Power					
Device Power	11	24	25	Vdc	per DeviceNet spec.
Discrete Inputs					
Inputs	11	24	25	Vdc	
Open, Close Outputs					
Max voltage			25	Vdc	
Output current	0	0.02	0.5	A	Each output simultaneously
Surge current			4	A peak	*Resistive load **Function of solenoid
Turn-on time		10*	40**	m	
Turn-off time		10*	40**	s	

Standard Conformity

Electromagnetic Compatibility	EN 61326-1:2006, EN 61000-4-2:2009, EN 61000-4-3:2006 inc. A2:2010, EN 61000-4-4:2004 inc. A1:2010, EN 61000-4-5:2006, EN 61000-4-6:2009, EN 61000-4-8:2010, EN 55011:2009 inc. A1:2010, EN 55014-1:2006
-------------------------------	--

Module Status (MS)

LED State	Module Status	Meaning
OFF	No power	There is no power though DeviceNet.
Green	Device operational	Operating normally.
Flashing Green	Device in standby	Needs commissioning.
Flashing Red	Minor fault	Recoverable fault.
Red	Unrecoverable fault	May need replacement.
Flashing Red/Green	Device self-testing	In self-test mode.

Network Status (NS)

LED State	Module Status	Meaning
OFF	No power/Not on-line	Has no power or has not completed the Dup_MAC_ID test.
Flashing Green	On-line, not connected	on-line but is not allotted to a Master.
Green	On-line	Operating normally.
Flashing Red	Connection time-out	One or more I/O connections are timed out.
Red	Critical link failure	Detected an error which makes it incapable of communicating on the link. (Bus off or Duplicate MAC ID.)

Bus Options DM/DN: DeviceNet Protocol (continued):

How to Install and Establish DeviceNet Communications

1. Make sure that the DeviceNet network is terminated properly.
2. Set the baud rate and address of the device if different from default (see next section on how to address and set baud rate).
3. Make sure that there is power on the DeviceNet network and that it is plugged into a Master device.
4. Connect the DeviceNet wires into the device.
5. In autobaud mode (default), the device Module Status LED (labeled MS) will continue to blink until the device recognizes valid traffic on the DeviceNet link and syncs to a specific baud rate.
6. In fixed baud rate mode, the device will undergo its initialization sequence, flashing both LEDs. After approximately 4 seconds, the Module Status LED (labeled "MS") will go on solid green and the Network LED will flash green.
7. The green Network Status LED (labeled "NS") will go on solid once the Master recognizes the unit on the link and allocates the connection (commissions it).
8. The device is now operating on the network.

How to Configure the DeviceNet Node Address and Baud Rate

1. The address and baud rate are pre-set to 63 and 125k baud at the factory.
2. The user may change these values via dip switch reconfiguration at any time (see the following tables)
3. A change to the baud rate will NOT take effect until the device is reset with either a RESET command or a power cycle.
4. A change to the address will be saved internally and will cause the unit to immediately undergo a soft reset. Upon restart the new address will be active, along with the new baud rate, if previously changed.

Address Selection Baud Rate Selection

Node Address	ADDRESS Switch Position						DeviceNet Baud Rate	DIP Switch Position	
	SW 1	SW 2	SW 3	SW 4	SW 5	SW 6		SW 7	SW 8
	Switch Position Values						125k	OFF	OFF
	32	16	8	4	2	1	250k	OFF	ON
0	OFF	OFF	OFF	OFF	OFF	OFF	500k	ON	OFF
1	OFF	OFF	OFF	OFF	OFF	ON	Autobaud	ON	ON
2	OFF	OFF	OFF	OFF	ON	OFF			
3	OFF	OFF	OFF	OFF	ON	ON			
4	OFF	OFF	OFF	ON	OFF	OFF			
5	OFF	OFF	OFF	ON	OFF	ON			
...									
62	ON	ON	ON	ON	ON	OFF			
63	ON	ON	ON	ON	ON	ON			

How to Read Discrete Input Data - DeviceNet

1. Plug the DeviceNet connector into the device. This powers the unit electronics.
2. Allocate a Poll Connection to the device from the client.
3. Perform a poll command to the device from the client. The device returns 2 bytes of data using Assembly Instance 1 (default).
4. The discrete input channel values will be available in the first 2 bits of data in the 1st byte returned. The bits are defined as:

Table 1 - Poll Response (Input Data) Assembly Instance 1

Byte	Bit Positions							
	7	6	5	4	3	2	1	0
1	Reset Switch State	Auxiliary Input State	Calibrate Close Switch State	Calibrate Open Switch State	Close Output State	Close Output State	Close Limit Switch State	Open Limit Switch State
2	0	0	0	0	0	Cycle Count Alarm	Close Timeout	Open Timeout

Table 2 - Poll Response (Input Data) Assembly Instance 2

Byte	Bit Positions							
	7	6	5	4	3	2	1	0
1	Reset Switch State	Auxiliary Input State	Calibrate Close Switch State	Calibrate Open Switch State	Close Output State	Close Output State	Close Limit Switch State	Open Limit Switch State
2	Analog Input Overcurrent	Analog Input Undercurrent	0	0	Analog Input Alarm	Cycle Count Alarm	Close Timeout Alarm	Open Timeout Alarm
3	Analog Input LSB (bits 0-7)							
4	0	0	0	0	0	0	Analog Input MSB	

Bus Options DM/DN: DeviceNet Protocol (continued)

Using Assembly instance 3 (Parameter 10), the cycle open and close times are added on to the poll bytes as shown below:

Table 3 - Poll Response Assembly Instance 3

Byte	Description
1	Input Status Bits
2	Alarm Bits
3	AI LSB
4	AI MSB
5	LS Byte of Last Open Time
6	MS Byte of Last Open Time
7	LS Byte of Last Close Time
8	MS Byte of Last Close Time

Using Assembly instance 4, the cycle count is added on to the poll bytes as shown below:

Table 4 - Poll Response Assembly Instance 4

Byte	Description
1	Input Status Bits
2	Alarm Bits
3	AI LSB
4	AI MSB
5	LS Byte of Last Cycle Count
6	MLS Byte of Last Cycle Count
7	MMS Byte of Last Cycle Count
8	MS Byte of Last Cycle Count

Assembly instance 5 incorporates all data, as shown:

Table 5 - Poll Response Assembly Instance 5

Byte	Description
1	Input Status Bits
2	Alarm Bits
3	AI LSB
4	AI MSB
5	LS Byte of Last Open Time
6	MS Byte of Last Open Time
7	LS Byte of Last Close Time
8	MS Byte of Last Close Time
9	LS Byte of Last Cycle Count
10	MLS Byte of Last Cycle Count
11	MMS Byte of Last Cycle Count
12	MS Byte of Last Cycle Count

Bus Options DM/DN: DeviceNet Protocol – How to Energize and De-energize Valve Solenoids

1. Reconnect the device and allocate a Poll Connection to the device from the client.
2. Issue a Poll command from the client with a data value of 00, 01, or 02. Each of the two possible outputs will be turned ON or OFF, as defined by a corresponding bit value of 1 or 0. Note that having both open and close bit set is an illegal state and will be ignored by the controller.

Table 6 - Poll Request (Output Data)

Byte	Bit Positions							
	7	6	5	4	3	2	1	0
1	0	0	0	Reset Cycle Count	Enable Cal Mode	Reset Alarms	Output 2	Output 1

Setting the Reset Alarms bit to 1 clears the Open and Close Time counters and resets all active alarm notification bits. As long as this bit is set, the alarms will be inactive. The Enable Cal Mode bit is set to 1 to allow calibration of the limit switches sense positions. When the device is commanded into Cal Mode, normal operation of the outputs is disabled. The Closed and Open limit switches can then set active, which will cause the associated input LEDs to be activated, along with activating the corresponding Input 1 or Input 2 status bits.

The Reset Cycle Count bit is set to 1 to clear the cycle counter.

Bus Options DM/DN: DeviceNet Protocol (continued) Parameters

The TopWorx™ device is software-configured for several parameters. Table 7 defines the legal values and the default values for the I/O configuration selections [available].

Table 7 - Configuration Parameters (Class 15)

Instance	Parameter Name	Values	Default Setting	Default Value	Description
1	Max Open Time	0 to 65535 (0-655.35 sec.)	Disabled	0	Maximum allowed time for valve to open before triggering alarm (in 10's of milliseconds)
2	Max Close Time	0 to 65535 (0-655.35 sec.)	Disabled	0	Maximum allowed time for valve to close before triggering alarm (in 10's of milliseconds)
3	Cycle Count Limit	0 to 42949672 95	Disabled	0	Maximum number of valve cycles before triggering alarm
4	Analog High Limit	0 to 1024	Disabled	1024	Highest analog value before triggering alarm
5	Analog Low Limit	0 to 1024	Disabled	0	Lowest analog value before triggering alarm
6	DeviceNet Fault Action	0 or 1	Use Fault Value	0	s0 = Use Fault Value 1 = Hold last State
7	DeviceNet Fault Value	0 or 1	OFF	0	0 = OFF 1 = OPEN 2 = CLOSE 3 = No Change
8	DeviceNet Idle Action	0 or 1	Use Fault Value	0	0 = Use Fault Value 1 = Hold Last State
9	DeviceNet Idle Value	0 or 1	OFF	0	0 = OFF 1 = OPEN 2 = CLOSE 3 = No Change
10	Assembly Configuration	0 or 4	Standard Assembly	1	See Table 1 through Table 5

Definitions of these Parameters are as follows:

1. **Max Open Time:** Maximum allowed time in 10's of milliseconds for valve to open before triggering alarm.
2. **Max Close Time:** Maximum allowed time in 10's of milliseconds for valve to close before triggering alarm.
3. **Cycle Count Limit:** Maximum number of valve cycles before triggering alarm.
4. ***Analog High Limit:** Highest analog value before triggering alarm.
5. ***Analog Low Limit:** Lowest analog value before triggering alarm.
6. **Output Fault Action:** Selection to determine whether each output will hold its last state or assume the value identified in the next parameter upon a device fault.
7. **Output Fault Value:** The value each output will assume after a Fault if Fault Value is selected above (hold last state is not selected).
8. **Output Idle Action:** Selection to determine whether each output will hold its last state or assume the value identified in the next parameter if an Idle Command is issued by the Master.
9. **Output Idle Value:** The value each output will assume upon an Idle Command if Idle Value is selected above (hold last state is not selected).
10. **Assembly Configuration:** This determines what data is returned in the poll response.

Bus Option PM: Profibus Protocol with Mechanical SPDT Switches

Wiring Diagram:

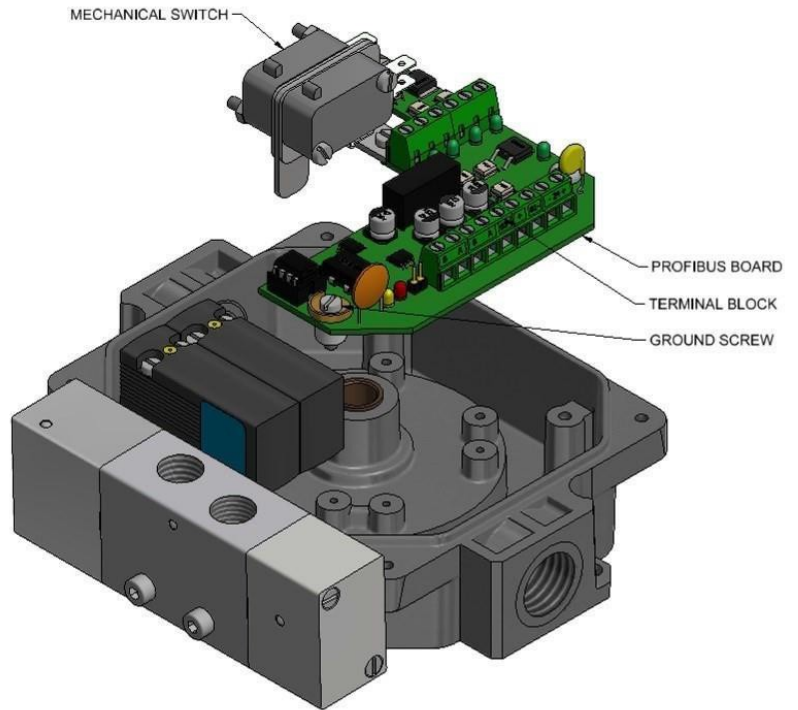
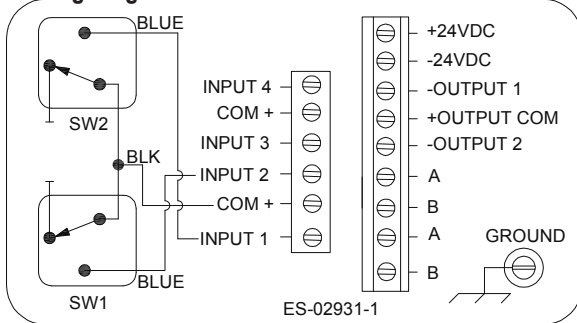

Bus Option PB: Profibus Protocol with Reed Switches

Wiring Diagram:

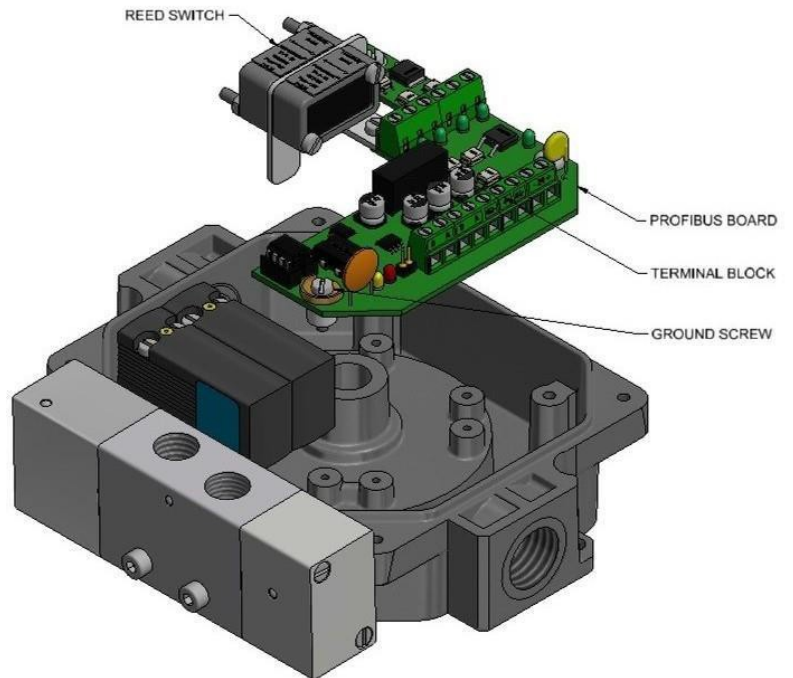
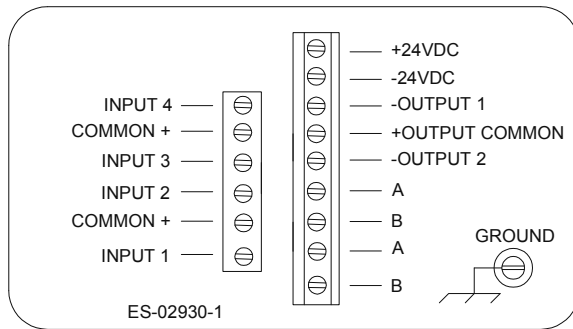

Bus Options PM/PB: Profibus Protocol (continued)

Type of Network	Device Bus
Physical Media	Twisted pair, fiber
Network Topology	Bus, Ring, Star
Maximum Devices	max. 126 stations on one bus (maximum of 244 bytes input and output data possible for each slave)
Maximum Distance	
DP	93.75Kbps and less - 1200 meters 500Kbps - 400 meters 1.5Mbps - 200 meters 12Mbps - 100
Maximum Distance with repeaters (max. of 9 repeaters can be used)	9,500 meters with repeaters
Communication Methods	Per-to-peer, multiPer-to-peer, st or cyclic master-slave (uses token passing sequence)
Primary Usage	Used for Discrete and Analog for PLC, Variable Speed Drives, Remote I/O communications
Power & Communications	Power is supplied separately from communications bus (can be supplied on a parallel power bus)
Device Power Supply	Devices are powered separately from communications bus. A 5A fuse must be placed in series with the input power terminals.
Wiring Types	Shielded twisted pair #22 AWG
Device Addressing	Handheld/Software only
Governing Body	PROFIBUS International (PI)
Website	www.profibus.com
Electromagnetic Compatibility	EN 61326-1:2006, EN 61000-4-2:1995 inc. A2:2001, EN 61000-4-3:2002, EN 61000-4-4:2004 inc. A1:2010, EN 61000-4-6:2009, EN 61000-4-8:1993 inc. A1:2001, EN 55011:2009 inc. A1:2010

NOTE: In order to meet EMC requirements, the Profibus communication cabling must be encased by conduit and properly grounded to the device housing.

Technical Data

Power Requirements	
PROFIDP 4120	24 VDC +-10% Max I = 350 mA maximum (solenoids/activated)

Profibus Info	
ID	09ED HEX
GSD file	TWIS09ED.GSD
Transmission Speed	12Mbaud (max)

Line Parameters	Line Type A	Line Type B
Impedance	135 to 165	100 to 130
Capacitance per unit length	<30	<60
Loop resistance (V/km)	110	---

Recommended Line Lengths							
Transmission rate (kbaud)	9.6	19.2	93.75	187.5	500	1200	1500
Line Type A	1200	1200	1200	1000	400	200	100
Line Type B	1200	1200	1200	600	200	-	-

Software Parameters

Output Byte		Fail Closed	Fail Open	Dual Coil
Bits				
7	n/a	n/a	n/a	n/a
6	n/a	n/a	n/a	n/a
5	n/a	n/a	n/a	n/a
4	n/a	n/a	n/a	n/a
3	n/a	n/a	n/a	n/a
2	n/a	n/a	n/a	n/a
1	Output 2	n/a	n/a	High Closed
0	Output 1	High Open	High Closed	High Open
		Low Closed	Low Open	

Input Byte 1		
Bits		
7	n/a	n/a
6	n/a	n/a
5	n/a	n/a
4	n/a	n/a
3	SPARE	Input 4
2	SPARE	Input 3
1	High Closed	Input 2
0	High Open	Input 1

Diagnostic Byte 1	
Bits	
7	n/a
6	n/a
5	n/a
4	n/a
3	n/a
2	Hard Wired high
1	Hard Wired high
0	Hard Wired high

4-20mA Transmitter: Options EX/KX/MX/TX

Wiring Diagrams:

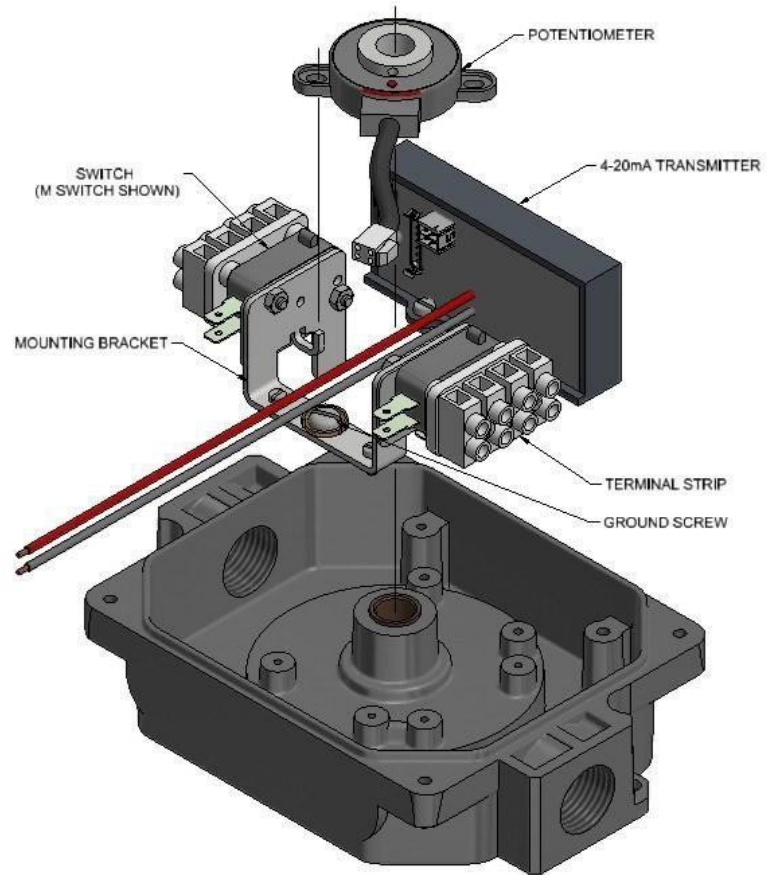
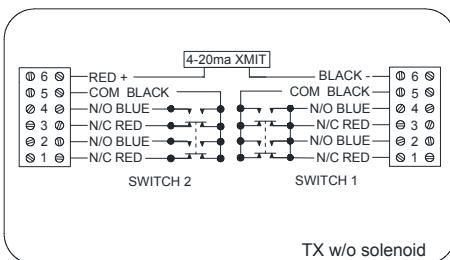
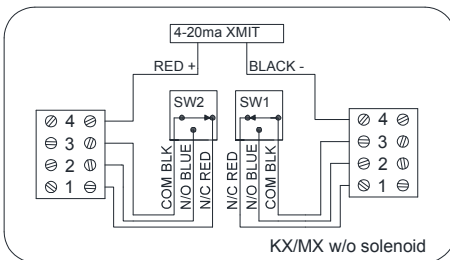
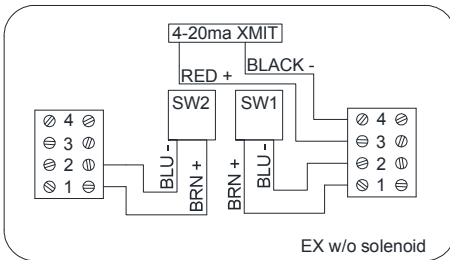

ELECTRICAL DATA	
Voltage Input Range	8.5 - 34 Volts DC
Standard Output Signal	Two wire 4-20mA with out of range indication
Input Polarity	Bi-Directional
Primary Usage	The 2-wire 4-20mA transmitter will generate a nominal 4-20mA output for full-range actuation of the valve. The device will generate signals above 20mA and below 4mA to indicate out of range rotation.
Rotation	The factory setting is 180 degree maximum for counterclockwise rotation and 90 degree maximum for counterclockwise rotation. Minimum rotation is 20 degrees in either direction. Contact customer service for rotations above factory settings.
Modes	Optional linear and rotary modes
Linearity	+/- 1%*
Repeatability	0.3%*
Hysteresis	0.5%*
Temperature	-40°C to 85°C
Electromagnetic Compatibility	EN 61326-1:2006, EN 61000-4-2:1995 inc. A1:1998 & A2:2001, EN 61000-4-3:2002, EN 61000-4-4:2004, EN 61000-4-5:1995 inc. A1:2001, EN 61000-4-6:2009, EN 55011:2009 inc. A1:2010
*Indicated linearity, repeatability and hysteresis is for the device only. Installed specifications will depend on the total mechanical and electrical system's capability.	

4-20mA Transmitter: Protocol (continued)

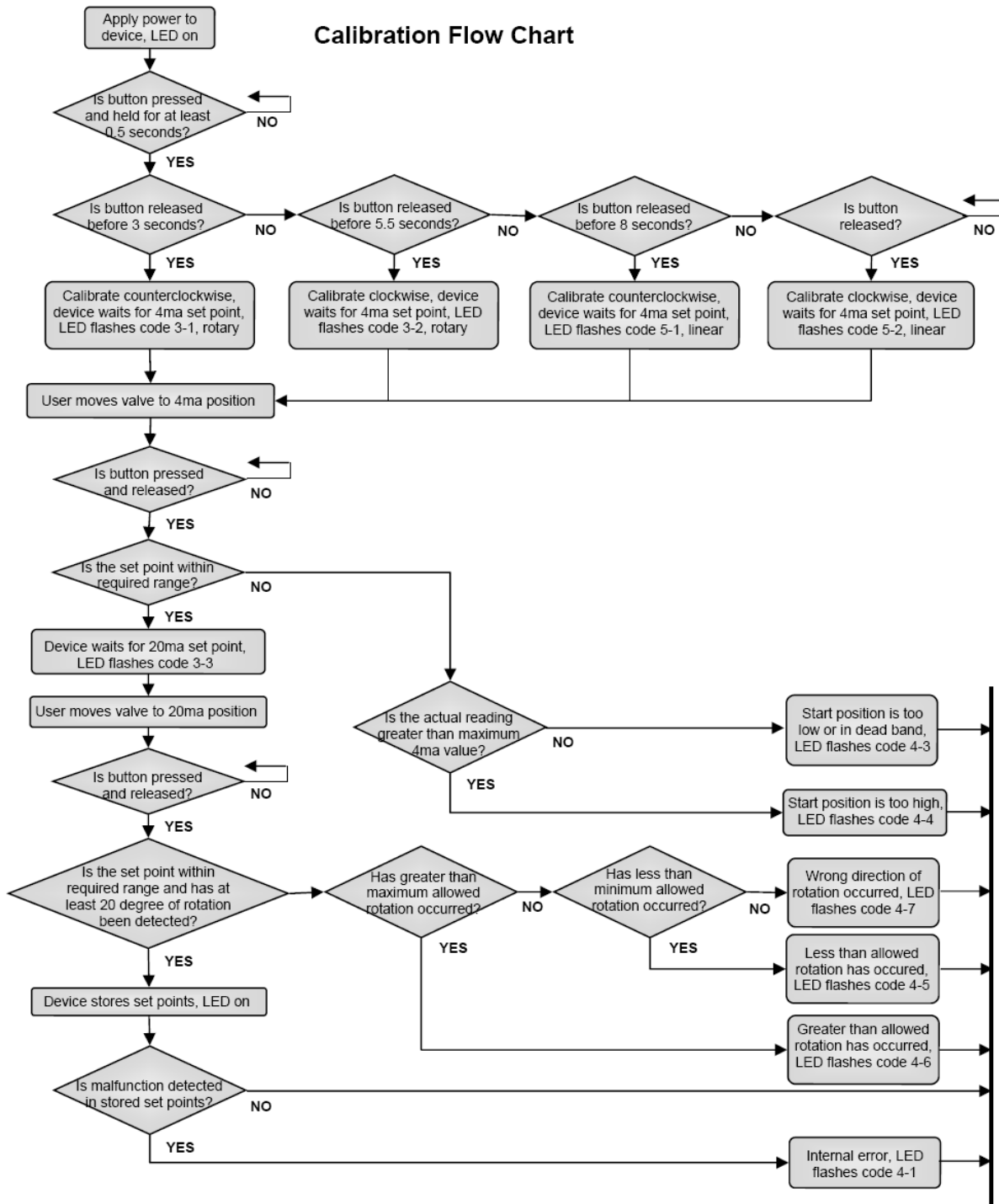

Operation of the 4-20mA Current Position Transmitter

During run mode, the 4-20mA position transmitter will output 4-20mA for valve positions between and including the set points. In rotary mode, the module has an optional over or under travel correction if the valve position exceeds the high or low set point by +/-3%. In other words, the output will be 4 mA for travel within 3% under the low-end set point and 20 mA for travel within 3% over the high-end set point. If the travel exceeds this 3% over/undershot, the actual value will be output. The other user-selectable option is to calibrate the device without the over and under travel capability (Linear Mode). See the calibration flowchart in the document for additional information.

4-20mA Transmitter: Protocol (continued)

Troubleshooting Error Code and problem Shooting

Problem	Probable Cause/Solution
Transmitter Module has no current output	If the LED on the Transmitter Module is not lit\ <ul style="list-style-type: none"> - Loose or shorted signal connection (fix connection) - Controller Board not responding (Replace Transmitter Module) If the LED on the Circuit Board is lit <ul style="list-style-type: none"> - Potentiometer is disengaged from shaft (must be returned for repair) - Defective controller board (Replace Transmitter Module)
Transmitter does not output 4 or 20mA (+/-1%) at desired end of travel	<ul style="list-style-type: none"> - Unit not calibrated (calibrate) - Unit is calibrated (recalibrate - if still fails, replace board)
Output is not linear or does not track valve position or rotation	Input signal is not linear <ul style="list-style-type: none"> - Linkage or drive mechanism is introducing non-linearity - Unit is not calibrated (calibrate)
Error Code 4-3	Start position is too low or in the dead-band position.
Error Code 4-4	Start position is too high
Error Code 4-5	Start and stop positions are less than 20°, increase valve rotation between start and stop positions to greater than 320°.
Error Code 4-6	Rotation has exceeded 320° limit. Decrease valve rotation between start and stop positions to less than 320°.
Error Code 4-7	Calibration rotation was in the wrong direction or the potentiometer passed through the dead-band position.
Error Code 4-1	Internal error has occurred. Recalibrate, if error continues, replace module.

LED Flash Code Diagram

Flash Codes (first count - second count)	Interpretations
0-0	Calibrated
3-1	Counter-Clockwise Calibration, Waiting to calibrate the 4mA position, Rotary Mode
3-2	Clockwise Calibration, Waiting to calibrate the 4mA position, Rotary Mode
3-3	Waiting for 20mA Full Open Setting Button Press
4-1	Calibrati Required
4-3	Calibration Start Value is Too Low
4-4	Calibration Start Value is Too High
4-5	End Value is Too Close to Start Value
4-6	Maximum Rotation Exceeded
4-7	Wrong Direction of Rotation
5-1	Counter-Clockwise Calibration, Waiting to calibrate the 4mA position, Linear Mode
5-2	Clockwise Calibration, Waiting to calibrate the 4mA position, Linear Mode



During calibration, make sure the potentiometer is not rotating through its deadband area. The red dot located on the potentiometer should not rotate through the area marked with red during the full rotation of the valve. If it does, reposition the shaft.

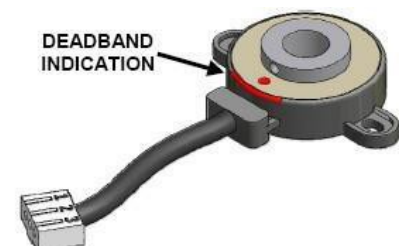

Integrated Pneumatic Pilots

All 15mm Pilot Valves feature:

- Heat-resistant bobbin molded with 30% glass-filled polyester (PBT)
- Class H 200°C copper wire according to IEC 317-8
- Encapsulation with specially designed, high-quality, glass-filled polyamide (PA66)
- Stainless steel guiding tube
- Plunger and core made of magnetic stainless steel specially designed for solenoid applications

Contact factory for technical pilot valve information.

Pneumatic Hookup Procedures

Prior to connecting the supply air to the spool valve, flush the system to remove any debris or contaminants. Galvanized pipe can easily flake and contaminate the system and therefore is not recommended. A 40-micron point of use filter at every device is recommended.

2-Way Spool Valves

The TopWorx™ spool valve is a 5 port, 2-way valve driven by an internally mounted pilot valve. The spool valve supply port and work ports are marked as follows:

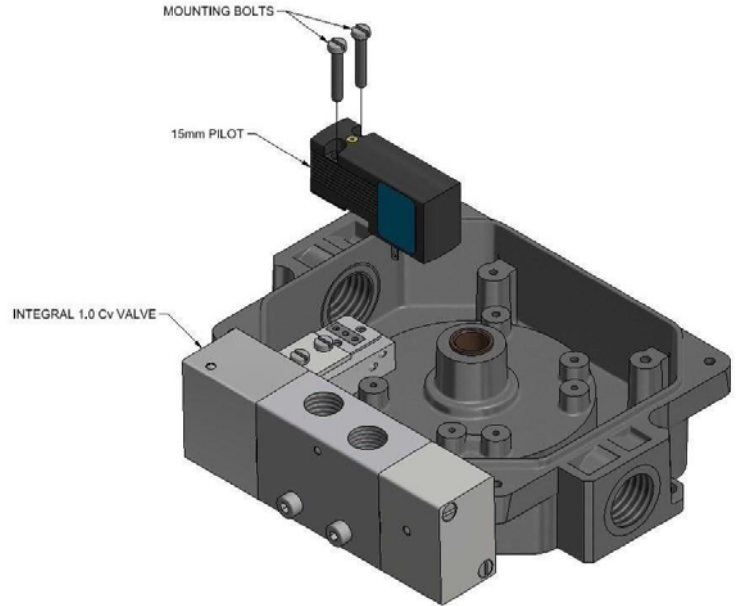
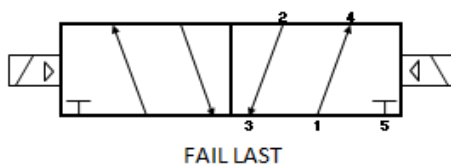
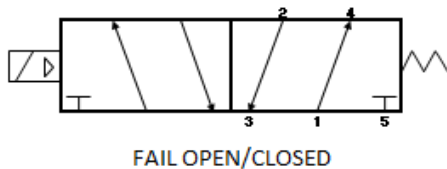
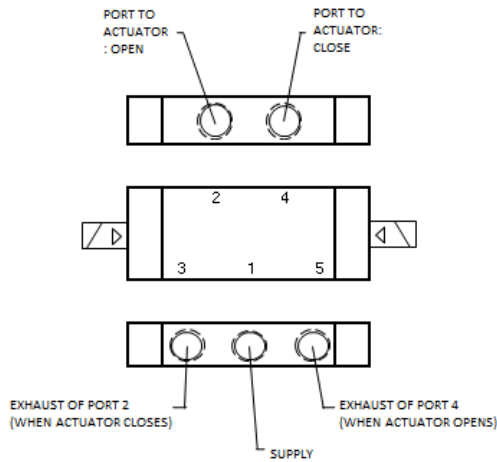

Spool Valve Specifications	
Medium	Dried, filtered air (40-micron)
Max Operating Pressure	100psi (0.7 MPa) (6.89Bar)
Min Operating Pressure	30psi (0.28 MPa) (2.76Bar)
Ambient Temperature Range	Refer to Product Nameplate Marking
Environment Rating	Type 4, 4X, IP67
Port Size	1/4" NPT or BSP for 1.0Cv valve Exhaust ports are 1/8" NPT or BSP
Valve Body	Available in Hardcoat Anodized Aluminum or 316 Stainless Steel
Valve Seals	Buna-N/EPDM

Highly Recommended

TopWorx™ highly recommends Loctite 567 brand thread sealant. Do not use a hard setting pipe compound. If Teflon thread seal tape is used, start the wrap on the second thread from the leading thread of the fitting. This will prevent tape shreds from contaminating the spool valve seals.

Breathers (AL-M30) should be installed in the exhaust ports, when NPT threads are specified, to keep debris from falling into the spool valve and damaging the seals. This must be addressed prior to installation, or storage.

A flow control may be used in Port 3, but should NEVER BE USED in Port 5. Any blockage or restriction may cause an internal pressure build-up inside the enclosure and pose a safety issue.

Maintenance

No maintenance is required. Bearing's internal diameter should be checked after 1 million cycles for wear. Required dimension should be between 10.00 to 10.05mm. Switch setting can be checked periodically.

Aggressive substances: e.g. acidic liquids or gases that may attack metals or solvents that may affect polymeric materials. If the equipment is likely to encounter aggressive substances, then it is the responsibility of the user to take suitable precautions that prevent it from being adversely affected, thus ensuring that the type of protection provided by the equipment is not compromised.

Suitable precautions: e.g. regular checks as part of routine inspections or establishing from the material's datasheets that it is resistant to specific chemicals. If in doubt, contact TopWorx™ for assistance.

Area Classifications

Intrinsically Safe Protection Method: Intrinsically safe units are designed to operate on very low current. A current limiting barrier is required for safe operation. For detailed requirements and installation information, refer to the control drawing listed on the product nameplate.

Non-Incendive Protection Method: Non-incendive units are designed with circuitry in which any arc or thermal effect produced, under intended operating conditions of the equipment, is not capable of igniting the flammable gas, vapor or dust-air mixtures.

General Purpose Protection Method: General purpose units are designed to be operated in areas free from flammable gas, vapor, or dust-air mixtures.

Approvals & Certifications

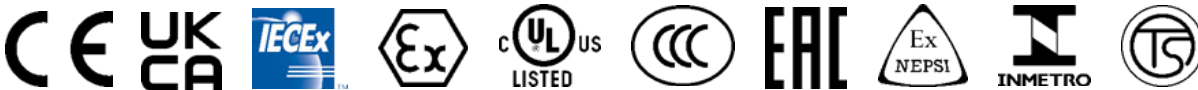

Ex ia IIC T* Gb; Ex tb IIIC T* Db
 IECEx SIR 13.0146X / Sira 13ATEX2364X / CSAE 21UKEX2698X
 USL/CNL Class I, Div 1, GrABCD; Class 2, Div 1 GrEFG
 UL File E125326
 EAC RU C-US.MIO62.B.00209-19
 NEPSI (SITiiAS): GYJ20.1276X
 InMetro UL-BR 18.0101X
 PESO: P469664/2
 (ITRI) 2022 07-00006X

USL/CNL General Purpose
 UL File E359150

Environmental Ratings: Type 4, 4X; IP 64/66/67

Conformance to Directives: ATEX 2014/34/EU, EMC 2014/30/EU, LVD 2014/35/EU

*Operating and Ambient temperature ratings vary depending on bus/sensor option(s), reference certificate for specific markings available.

Consult factory for certification questions or to request a custom product.

Ex nA nC IIC T* Gc; Ex tb IIIC T* Dc
 IECEx SIR 12.0089X / Sira 12ATEX4210X / CSAE 21UKEX4723X
 USL/CNL Class I, Div 2, GrABCD; Class II, Div 2, GrFG
 UL File E125326
 InMetro UL-BR 18.0099X
 (ITRI) 2021 07-00252X
 CCC: 2021312304001240; 2022312304001255; 2022312304001254

Safe Use - Special Conditions of Safe Use (All installations)

For Intrinsically Safe applications:

- The 4-20mA loop circuit and the various additional sub-assemblies (switches, sensors, valves, etc.) shall be treated as separate intrinsically safe circuits.
- The entity parameters for simple switches that are not covered by a certificate are $U_i = 30\text{ V}$, $I_i = 200\text{ mA}$ and $P_i = 0.72\text{ W/switch (T4)}$ or $P_i = 0.34\text{ W/switch (T6)}$. The entity parameters of certified devices fitted shall be obtained from the applicable certificate.
- The supply values, when option S LED board is fitted, are $U_{max} = 24\text{ V}$, $I_{max} = 250\text{ mA}$ and $P_{max} = 1.2\text{ W}$
- When the supply to the Series 36 & 36SD GO Switches do not exceed 60 VAC/85VDC, the supply shall be protected such that transients are limited to a maximum of 119 V. If the supply is above 60VAC / 85 VDC but not exceeding 120 VAC, the supply shall be protected such that the transients are limited to a maximum of 238 V.

For Increased Safety applications:

- The enclosure has the following limiting temperatures: -50°C to $+180^\circ\text{C}$ for Silicone O-rings.

For Increased Safety and Non-Incendive applications:

- When fitted with an indicator dome, the non-metallic parts incorporated in the enclosure of this equipment may generate an ignition- capable level of electrostatic discharge. Therefore, the equipment shall only be cleaned with a damp cloth.

Consult Factory for Recommended Operating Temperature

PRODUCT SUPPORT INFORMATION

Please contact factory or Global Support Offices for additional technical information and support on TopWorx™ ESD Re-Design with GO™ product.

Americas

3300 Fern Valley Road,
Louisville, Kentucky 40213 USA
+1 502 969 8000
info.topworx@emerson.com

Asia-Pacific

1 Pandan Crescent
Singapore 128461
+65 6891 7550
info.topworx@emerson.com

Europe, Middle East, Africa

Horsfield Way
Bredbury Industrial Estate
Stockport SK62SU
United Kingdom
+44 0161 406 5155
info.topworx@emerson.com

Visit www.topworx.com for comprehensive information on our company, capabilities, and products – including model numbers, data sheets, specifications, dimensions, and certifications.

info.topworx@emerson.com

www.topworx.com

The Emerson logo is a trademark and a service mark of Emerson Electric Co. ©2020 Emerson Electric Co. ©2020 TopWorx™. All rights reserved. TopWorx™ and GO™ Switch are trademarks of TopWorx™. All other marks used in this document are the property of their respective owners. Information contained herein, including product specifications, is subject to change without notice.