

# Micro Motion™ Gas Specific Gravity Meters (SGM)

Configuration and Use Manual



## Safety messages

Safety messages are provided throughout this manual to protect personnel and equipment. Read each safety message carefully before proceeding to the next step.

## Safety and approval information

This Micro Motion product complies with all applicable European directives when properly installed in accordance with the instructions in this manual. Refer to the EU declaration of conformity for directives that apply to this product. The EU declaration of conformity, with all applicable European directives, the complete ATEX Installation Drawings and Instructions, the IECEx Installation Instructions for installations outside of the European Union, and the CSA Installation Instructions for installations in North America are available on the internet at [www.emerson.com](http://www.emerson.com) or through your local Micro Motion support center.

Information affixed to equipment that complies with the Pressure Equipment Directive, can be found on the internet at [www.emerson.com](http://www.emerson.com).

For hazardous installations in Europe, refer to standard EN 60079-14 if national standards do not apply.

## Other information

Full product specifications can be found in the product data sheet. Troubleshooting information can be found in the configuration manual. Product data sheets and manuals are available from the Micro Motion web site at [www.emerson.com](http://www.emerson.com).

## Return policy

Follow Micro Motion procedures when returning equipment. These procedures ensure legal compliance with government transportation agencies and help provide a safe working environment for Micro Motion employees. Micro Motion will not accept your returned equipment if you fail to follow Micro Motion procedures.

Return procedures and forms are available on our web support site at [www.emerson.com](http://www.emerson.com), or by phoning the Micro Motion Customer Service department.

## Emerson Flow customer service

Email:

- Worldwide: [flow.support@emerson.com](mailto:flow.support@emerson.com)
- Asia-Pacific: [APflow.support@emerson.com](mailto:APflow.support@emerson.com)

Telephone:

North and South America		Europe and Middle East		Asia Pacific	
United States	800-522-6277	U.K. and Ireland	0870 240 1978	Australia	800 158 727
Canada	+1 303-527-5200	The Netherlands	+31 (0) 70 413 6666	New Zealand	099 128 804
Mexico	+52 55 5809 5010	France	+33 (0) 800 917 901	India	800 440 1468
Argentina	+54 11 4809 2700	Germany	0800 182 5347	Pakistan	888 550 2682
Brazil	+55 15 3413 8000	Italy	+39 8008 77334	China	+86 21 2892 9000
Chile	+56 2 2928 4800	Central & Eastern	+41 (0) 41 7686 111	Japan	+81 3 5769 6803
Peru	+51 15190130	Russia/CIS	+7 495 995 9559	South Korea	+82 2 3438 4600
		Egypt	0800 000 0015	Singapore	+65 6 777 8211
		Oman	800 70101	Thailand	001 800 441 6426
		Qatar	431 0044	Malaysia	800 814 008
		Kuwait	663 299 01		
		South Africa	800 991 390		
		Saudi Arabia	800 844 9564		
		UAE	800 0444 0684		

# Contents

<b>Chapter 1</b>	<b>Before you begin.....</b>	<b>7</b>
	1.1 About this manual.....	7
	1.2 Hazard messages.....	7
	1.3 Model codes and device types.....	7
	1.4 Communications tools and protocols.....	8
	1.5 Related documentation.....	8
<b>Chapter 2</b>	<b>Orientation and planning.....</b>	<b>9</b>
	2.1 Functional view of the SGM.....	9
	2.2 Terms and definitions.....	13
	2.3 Primary process variable: specific gravity, molecular weight, or relative density.....	14
	2.4 Equations used to calculate specific gravity, molecular weight, and relative density.....	18
<b>Chapter 3</b>	<b>Quick start.....</b>	<b>21</b>
	3.1 Power up the transmitter.....	21
	3.2 Check meter status.....	21
	3.3 Make a startup connection to the transmitter.....	22
<b>Chapter 4</b>	<b>Introduction to configuration and commissioning.....</b>	<b>23</b>
	4.1 Default values.....	23
	4.2 Enable access to the off-line menu of the display.....	25
	4.3 Disable HART security.....	25
	4.4 Set the HART lock.....	26
	4.5 Restore the factory configuration.....	26
<b>Chapter 5</b>	<b>Purging and calibration.....</b>	<b>27</b>
	5.1 On-site setup requirements.....	27
	5.2 Prepare for SGM purging and calibration.....	27
	5.3 Purge and purge-cycle the SGM device.....	31
	5.4 Calibrate the SGM device.....	33
	5.5 Review data for all calibrations.....	44
	5.6 Change the label for the active calibration.....	44
	5.7 Select the active calibration.....	44
<b>Chapter 6</b>	<b>Configure measurement units using the display.....</b>	<b>45</b>
	6.1 Configure measurement units using the display.....	45
<b>Chapter 7</b>	<b>Configure process measurement using ProLink III.....</b>	<b>47</b>
	7.1 Configure specific gravity, molecular weight, or relative density parameters using ProLink III....	47
	7.2 Configure temperature measurement using ProLink III.....	48
	7.3 Configure the pressure input.....	51
	7.4 Configure gas compressibility measurement using ProLink III.....	53

	7.5 Configure base density calculations using ProLink III.....	56
	7.6 Configure line density calculations using ProLink III .....	58
	7.7 Configure energy content measurement using ProLink III.....	59
	7.8 Set up concentration measurement using ProLink III.....	63
<b>Chapter 8</b>	<b>Configure process measurement using a field communicator.....</b>	<b>65</b>
	8.1 Configure density measurement using a field communicator .....	65
	8.2 Configure temperature measurement using a field communicator .....	67
	8.3 Configure gas measurement using a field communicator.....	69
	8.4 Set up concentration measurement using a field communicator.....	75
<b>Chapter 9</b>	<b>Configure device options and preferences.....</b>	<b>77</b>
	9.1 Configure the transmitter display.....	77
	9.2 Enable or disable the Acknowledge All Alerts display command.....	79
	9.3 Configure security for the display menus .....	79
	9.4 Configure alert handling.....	80
	9.5 Configure informational parameters.....	83
<b>Chapter 10</b>	<b>Integrate the meter with the control system.....</b>	<b>85</b>
	10.1 Configure Channel B.....	85
	10.2 Configure the mA Output.....	85
	10.3 Configure the Discrete Output.....	91
	10.4 Configure an enhanced event.....	93
	10.5 Configure HART/Bell 202 communications .....	94
	10.6 Configure Modbus communications.....	100
	10.7 Configure Digital Communications Fault Action.....	102
<b>Chapter 11</b>	<b>Complete the configuration.....</b>	<b>103</b>
	11.1 Test or tune the system using sensor simulation.....	103
	11.2 Back up transmitter configuration.....	103
	11.3 Enable HART security.....	103
<b>Chapter 12</b>	<b>Transmitter operation.....</b>	<b>105</b>
	12.1 Record the process variables.....	105
	12.2 View process variables and diagnostic variables.....	105
	12.3 View and acknowledge status alerts.....	106
<b>Chapter 13</b>	<b>Measurement support.....</b>	<b>111</b>
	13.1 Adjust temperature measurement with Temperature Offset or Temperature Slope .....	111
	13.2 Adjust concentration measurement with Trim Offset.....	112
	13.3 Adjust concentration measurement with Trim Slope and Trim Offset.....	113
	13.4 Set up user-defined calculations.....	114
<b>Chapter 14</b>	<b>Troubleshooting.....</b>	<b>119</b>
	14.1 Quick guide to troubleshooting.....	119
	14.2 Verify performance.....	120
	14.3 Perform the Known Density Verification procedure.....	121

14.4	Check power supply wiring.....	123
14.5	Check grounding.....	124
14.6	Perform loop tests.....	124
14.7	Status LED states.....	128
14.8	Status alerts, causes, and recommendations.....	128
14.9	Primary process variable measurement problems.....	133
14.10	Temperature measurement problems.....	134
14.11	Gas measurement problems.....	135
14.12	Concentration measurement problems.....	135
14.13	Milliamp output problems.....	136
14.14	Discrete Output problems.....	138
14.15	Time Period Signal (TPS) output problems.....	138
14.16	Using sensor simulation for troubleshooting.....	139
14.17	Trim mA outputs.....	139
14.18	Check HART communications.....	140
14.19	Check Lower Range Value and Upper Range Value.....	142
14.20	Check mA Output Fault Action.....	142
14.21	Check for radio frequency interference (RFI).....	142
14.22	Check for leakage.....	143
14.23	Check the coalescing filter.....	143
14.24	Check the drive gain.....	144
14.25	Check the pickoff voltage.....	145
14.26	Check for internal electrical problems.....	146
14.27	Locate a device using the HART 7 Squawk feature.....	146
<b>Appendix A</b>	<b>Factory test certificate.....</b>	<b>147</b>
	A.1 Sample factory test certificate.....	147
<b>Appendix B</b>	<b>Using the transmitter display.....</b>	<b>149</b>
	B.1 Components of the transmitter interface.....	149
	B.2 Use the optical switches.....	149
	B.3 Access and use the display menu system.....	149
	B.4 Display codes for process variables.....	153
	B.5 Codes and abbreviations used in display menus.....	154
<b>Appendix C</b>	<b>Using ProLink III with the transmitter.....</b>	<b>167</b>
	C.1 Basic information about ProLink III.....	167
	C.2 Connect with ProLink III.....	168
<b>Appendix D</b>	<b>Using the field communicator with the transmitter.....</b>	<b>179</b>
	D.1 Basic information about a field communicator.....	179
	D.2 Connect with a field communicator.....	180
<b>Appendix E</b>	<b>Three-point calibration.....</b>	<b>183</b>
<b>Appendix F</b>	<b>Calculate measurement errors using reference chamber pressure.....</b>	<b>187</b>

F.1 Calculation aid and examples..... 188

# 1 Before you begin

## 1.1 About this manual

This manual helps you configure, commission, use, maintain, and troubleshoot the SGM.

---

### NOTICE

The information in this document assumes that users understand basic meter installation, configuration, and maintenance concepts and procedures.

---

## 1.2 Hazard messages

This document uses the following criteria for hazard messages based on ANSI standards Z535.6-2011 (R2017).

### DANGER

Serious injury or death will occur if a hazardous situation is not avoided.

### WARNING

Serious injury or death could occur if a hazardous situation is not avoided.

### CAUTION

Minor or moderate injury will or could occur if a hazardous situation is not avoided.

---

### NOTICE

Data loss, property damage, hardware damage, or software damage can occur if a situation is not avoided. There is no credible risk of physical injury.

---

### Physical access

---

### NOTICE

Unauthorized personnel can potentially cause significant damage and/or misconfiguration of end users' equipment. Protect against all intentional or unintentional unauthorized use.

Physical security is an important part of any security program and fundamental to protecting your system. Restrict physical access to protect users' assets. This is true for all systems used within the facility.

---

## 1.3 Model codes and device types

Your device can be identified by the model code on the device tag.

Model code	Device nickname	I/O	Electronics mounting
SGM*****B	SGM TPS	<ul style="list-style-type: none"><li>• One mA Output</li><li>• One Time Period Signal output</li><li>• RS-485 terminals</li></ul>	Integral

Model code	Device nickname	I/O	Electronics mounting
SGM*****C	SGM mA	<ul style="list-style-type: none"> <li>Two mA Outputs</li> <li>RS-485 terminals</li> </ul>	Integral
SGM*****D	SGM DO	<ul style="list-style-type: none"> <li>One mA Output</li> <li>One Discrete Output</li> <li>RS-485 terminals</li> </ul>	Integral
SGM*****E	SGM Fixed	<ul style="list-style-type: none"> <li>One Time Period Signal output</li> <li>One mA Output fixed to temperature</li> </ul>	Integral

### Restriction

The SGM mA and SGM DO support a complete set of application and configuration options. The SGM TPS and SGM Fixed support a subset of application and configuration options. Refer to the product data sheet for details.

## 1.4 Communications tools and protocols

You can use several different communications tools and protocols to interface with the device. You may use different tools in different locations or for different tasks.

Communications tool	Supported protocols
ProLink III	<ul style="list-style-type: none"> <li>Modbus/RS-485</li> <li>HART/Bell 202</li> <li>Service port</li> </ul>
Field communicator	HART/Bell 202

### Tip

You may be able to use other communications tools from Emerson Process Management, such as AMS Suite: Intelligent Device Manager, or the Smart Wireless THUM™ Adapter. Use of AMS or the Smart Wireless THUM Adapter is not discussed in this manual. For more information on the Smart Wireless THUM Adapter, refer to the documentation available at [www.emerson.com](http://www.emerson.com).

## 1.5 Related documentation

You can find all product documentation on the product documentation DVD shipped with the product or at [www.emerson.com](http://www.emerson.com).

See any of the following documents for more information:

- Micro Motion Specific Gravity Meters (SGM) Product Data Sheet*
- Micro Motion Specific Gravity Meters (SGM) Installation Manual*
- Modbus Interface Tool*



## 2 Orientation and planning

### 2.1 Functional view of the SGM

#### SGM components view

The following figures illustrate the major components of the SGM. Depending on the order, some components may be shipped with the device or supplied by the customer.

**Figure 2-1: Typical SGM installation**

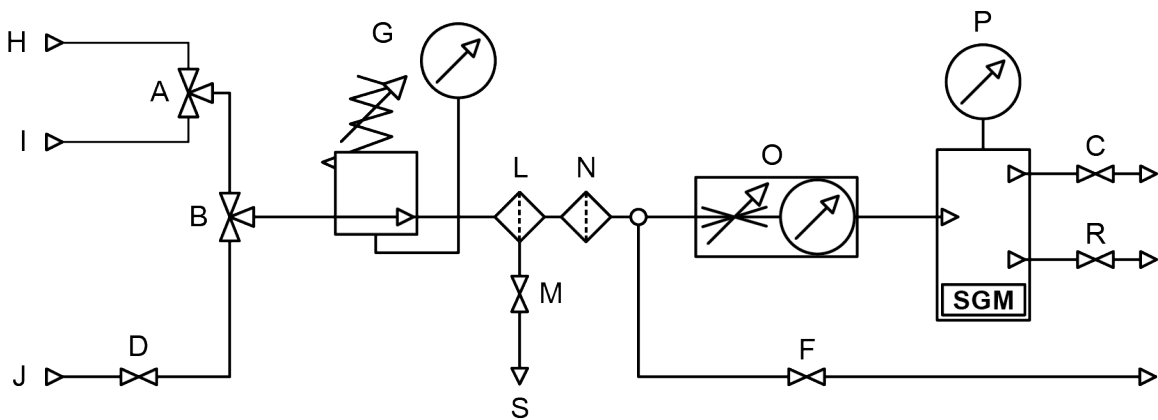

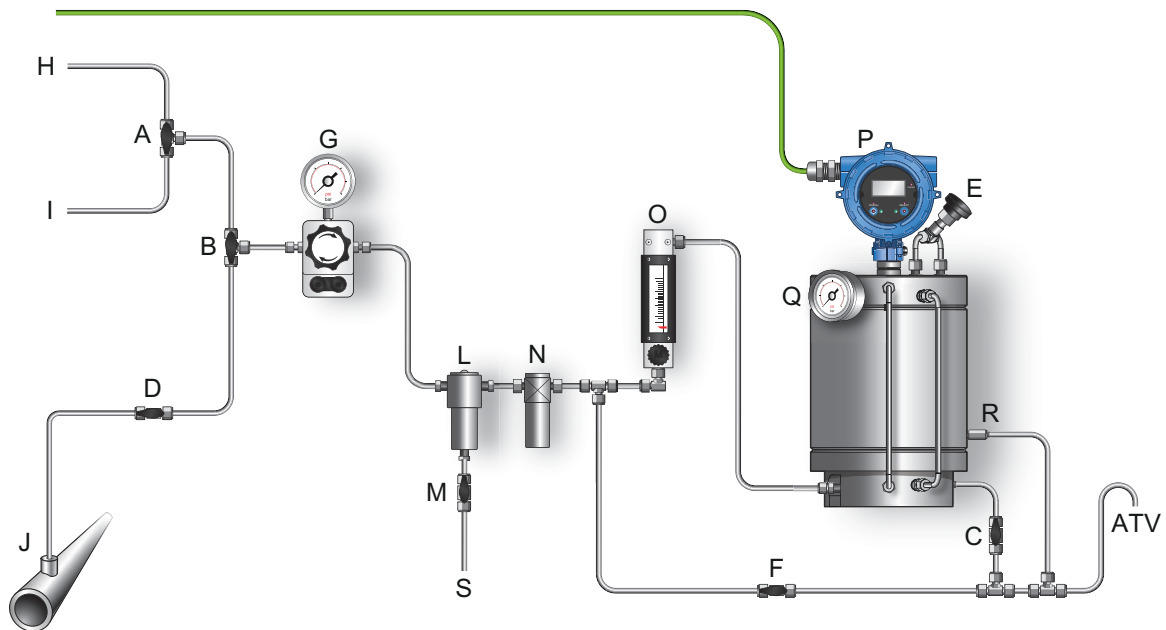

- A. Calibration gas selector three-way valve
- B. Process/Calibration gas selector three-way valve
- C. Outlet two-way valve
- D. Process gas inlet two-way valve
- E. Chamber fill valve
- F. Purge two-way valve
- G. Pressure regulator with gauge
- H. Calibration gas 1 inlet
- I. Calibration gas 2 inlet
- J. Process gas sampling point
- K. Tubing work (not shown in diagram)
- L. Coalescent filter
- M. Coalescent filter drain two-way valve
- N. Particle filter
- O. Flow meter
- P. Transmitter
- Q. Reference chamber pressure indicator
- R. Relief valve
- S. Drain

**ATV** Atmospheric Vent

### Complete sampling conditioning system

The SGM can be offered as a complete system shown in the following diagrams. The valves, filter, regulator, and internal piping will all be included in the system with an optional electric heater.

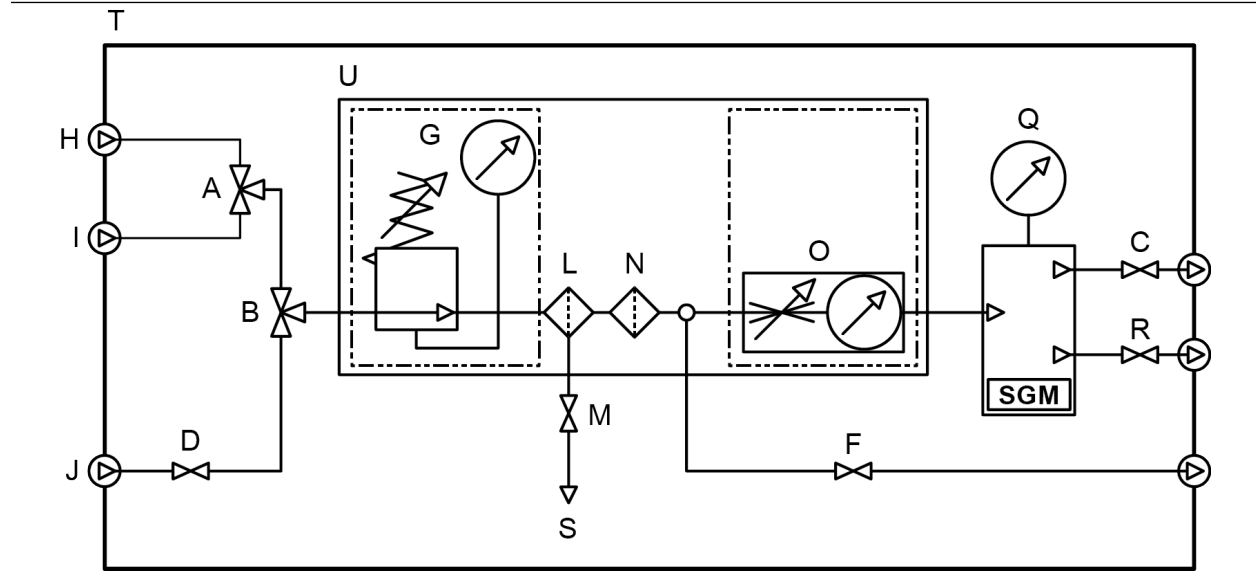

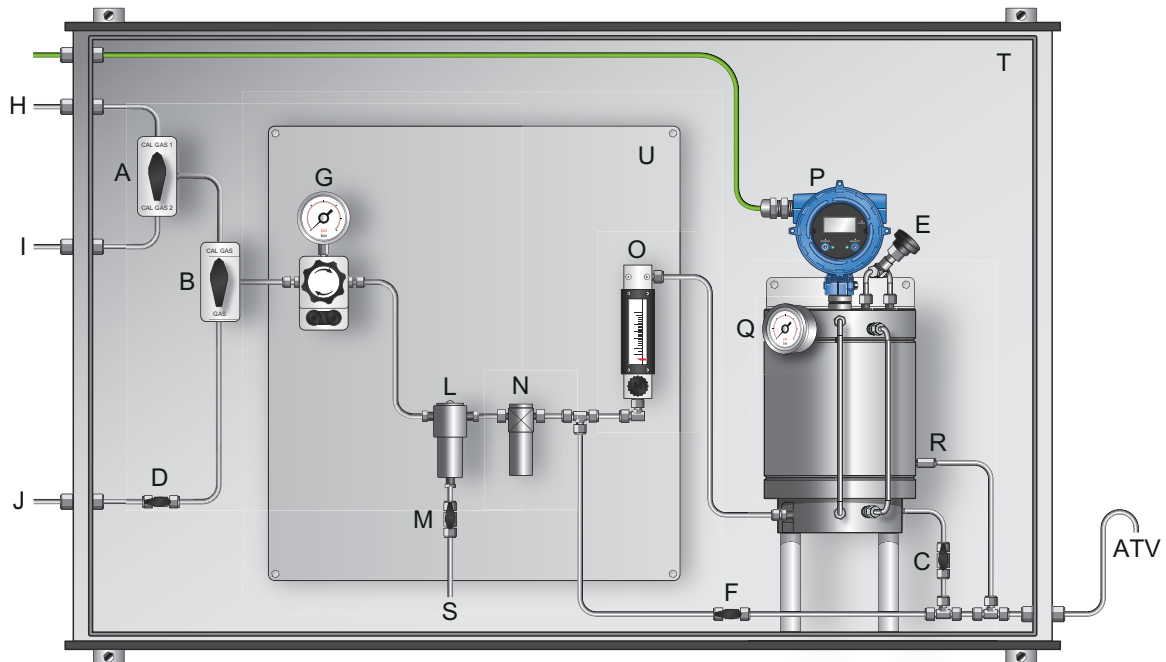

- A. Calibration gas selector three-way valve
- B. Process/Calibration gas selector three-way valve
- C. Outlet two-way valve
- D. Process gas inlet two-way valve
- E. Chamber fill valve
- F. Purge two-way valve
- G. Pressure regulator with gauge
- H. Calibration gas 1 inlet
- I. Calibration gas 2 inlet
- J. Process gas sample inlet
- K. Tubing work (not shown in diagram)
- L. Coalescent filter
- M. Coalescent filter drain two-way valve
- N. Particle filter
- O. Flow meter
- P. Transmitter
- Q. Reference chamber pressure indicator
- R. Relief valve
- S. Drain
- T. Enclosure
- U. Mounting plate

**ATV** Atmospheric Vent

## 2.2 Terms and definitions

Table 2-1: Terms used in meter setup and measurement

Term	Definition or usage
<b>Gas</b>	
Calibration gas	Two or three pure, traceable calibration gases (99.9%) with a lower and higher specific gravity/molecular weight as the process gas. Calibration gas can be the same specific gravity as the process gas.
Reference gas	The gas in the reference chamber. Typically, the process gas is used as the reference gas.
Sample gas	The gas stream to be measured by the meter.
<b>Pressure</b>	
Control pressure	The pressure of the reference gas in the reference chamber.
Line pressure	The pressure in the main pipeline, independent of the meter.
Sample pressure	The pressure of the sample gas after it passes through the pressure regulator.
Supply pressure	The pressure of the sample gas before it passes through the pressure regulator.
Vent pressure	The pressure required to force gas through the vent.
<b>Measurement</b>	
Base density (standard density, normal density)	The absolute density of a gas at reference conditions (base temperature and base pressure). Can be used to calculate standard volume flow from mass flow. Measured in user-specified units.
Calorific value	The amount of heat released during the combustion of a specified amount of a gas. Measured in units of energy per units of the gas. Energy = calorific value.
Compressibility factor “z”	The correction factor for interactive molecular behavior of non-ideal gas mixtures.
Concentration (purity of binary gas mixtures)	In a binary gas mixture, the quantity of the primary gas in comparison to the quantity of the secondary gas (contaminant). Measured in user-specified units.
Energy flow	The energy content of the process gas flowing through the pipe per unit of time. Measured in units of energy per units of time.
Molecular weight	The ratio of the average mass of one molecule of an element or compound to one twelfth of the mass of an atom of carbon-12. Typically measured in g/mol.
Net mass flow rate	The flow rate as measured in mass flow units and multiplied by the current concentration value.
Net volume flow rate	The flow rate as measured in volume flow units, corrected to base temperature and base pressure, and multiplied by the current concentration value.
Relative density	The ratio of the weight of a volume of gas (or gas mixture) to the weight of an equal volume of dry air, where the weights of both the gas and air are taken under identical conditions of temperature and pressure. Unitless.
Specific gravity	The ratio of the molecular weight of a gas (or gas mixture) to the molecular weight of dry air. The molecular weight of dry air is normally assumed to be 28.96469. Unitless.

**Table 2-1: Terms used in meter setup and measurement (continued)**

Term	Definition or usage
Wobbe index	The ratio of the calorific value of a gas to its specific gravity. Measured in volumetric units (BTU/SCF, and MJ/SCM).

## 2.3 Primary process variable: specific gravity, molecular weight, or relative density

The SGM can operate as a specific gravity meter, a molecular weight meter, or a relative density meter. Your choice determines the set of process variables that the meter can report, the methods used to measure and calculate them, and the data that you must supply during setup and configuration.

The primary process variable — specific gravity, molecular weight, or relative density — needs to be specified as part of the order. However, you can change the primary process variable during calibration.

### Related information

[Primary process variable and available gas process variables](#)

[Primary process variable, gas process variables, and required data](#)

### 2.3.1 Primary process variable and available gas process variables

The gas process variables that the SGM can report are determined by the primary process variable that you select during calibration.

Available process variables	Default measurement unit	Primary process variable		
		Specific gravity	Molecular weight	Relative density
Specific gravity	Unitless	✓	✓	
Molecular weight	g/mol	✓	✓	
Relative density	Unitless			✓
Base density	g/cm <sup>3</sup>	✓	✓	✓
Line density	g/cm <sup>3</sup>	✓	✓	✓
Line compressibility	Unitless	✓	✓	✓
Base compressibility	Unitless	✓	✓	✓
Calorific value	MJ/m <sup>3</sup>	✓	✓	
Wobbe index	MJ/m <sup>3</sup>	✓	✓	
Energy flow	MJ/hr	✓	✓	
Concentration (gas purity)	Concentration (% mass)	✓	✓	✓
Net mass flow rate	g/sec	✓	✓	✓
Net volume flow rate	l/sec	✓	✓	✓

## 2.3.2 Primary process variable, gas process variables, and required data

The gas process variables are calculated from a combination of measured variables, calculated variables, process data from external devices, and user-specified values. For each process variable that you want the meter to report, you must be able to supply all required external data and configuration values. Specific requirements are determined by the primary process variable.

### Note

The meter does not measure certain process variables directly. External devices are required for the following process variables:

- Line pressure
- Gas composition (% CO, % CO<sub>2</sub>, % H<sub>2</sub>, % N<sub>2</sub>)
- Flow rate (mass or volume)

### Note

- If you use temperature data from the meter, the data will represent the gas inside the measurement chamber.
- If you use temperature data from an external device, the data will represent the gas at the location of the temperature probe.

**Table 2-2: Gas measurement when the primary process variable is specific gravity**

Process variable to be reported		Process data provided by the SGM	Required process data from external devices	Required user-specified values
Specific gravity		Specific gravity		
Molecular weight		Specific gravity		Molecular weight of air
Base density		Molecular weight Base compressibility		Base pressure Base temperature
Line density		Temperature data from meter (RTD) <sup>(1)</sup> Base density Line compressibility Base compressibility	External temperature <sup>(2)</sup> Line pressure	Base pressure Base temperature
Line compressibility	NX 19	Sample temperature (RTD) <sup>(1)</sup> Specific gravity	External temperature <sup>(2)</sup> Line pressure % CO <sub>2</sub> % N <sub>2</sub>	Molecular weight of air
	NX 19 Mod	Sample temperature data from meter (RTD) <sup>(1)</sup> Specific gravity	External temperature <sup>(2)</sup> Line pressure % CO <sub>2</sub> % N <sub>2</sub>	

**Table 2-2: Gas measurement when the primary process variable is specific gravity (continued)**

Process variable to be reported		Process data provided by the SGM	Required process data from external devices	Required user-specified values
	NX 19 3h	Sample temperature data from meter (RTD) <sup>(1)</sup> Specific gravity Calorific value	External temperature <sup>(2)</sup> Line pressure % CO2 % N2	Molecular weight of air
Base compressibility	NX 19	Specific gravity	% CO2 % N2	Molecular weight of air Base temperature Base pressure
	NX 19 Mod	Specific gravity	% CO2 % N2	Base temperature Base pressure
	NX 19 3h	Specific gravity Calorific value	% CO2 % N2	Molecular weight of air Base temperature Base pressure
Calorific Value	AGA-5	Specific gravity	% CO % CO2 % H2 % N2	
Wobbe Index		Specific gravity Calorific value		
Energy Flow	Mass units	Line density <sup>(3)</sup> Calorific value	Mass flow rate (external or calculated)	
	Volume units	Line density <sup>(4)</sup> Calorific value	Volume flow rate (external or calculated)	

(1) Used when you want process variables to represent the gas in the measurement chamber.

(2) Used when you want process variables to represent the gas at the location of the temperature probe.

(3) Required only if you plan to use the calculated mass flow measurement unit as the measurement unit for energy flow.

(4) Required only if you plan to use the calculated volume flow measurement unit as the measurement unit for energy flow.

**Table 2-3: Gas measurement when the primary process variable is molecular weight**

Process variable to be reported	Process data provided by the SGM	Required process data from external devices	Required user-specified values
Molecular weight	Molecular weight		
Specific gravity	Molecular weight		Molecular weight of air
Base density	Molecular weight Base compressibility		Base pressure Base temperature



**Table 2-3: Gas measurement when the primary process variable is molecular weight (continued)**

Process variable to be reported		Process data provided by the SGM	Required process data from external devices	Required user-specified values
Line density		Sample temperature data from meter (RTD) <sup>(1)</sup> Molecular weight Line compressibility	External temperature <sup>(2)</sup> Line pressure	
Line compressibility	NX 19	Sample temperature <sup>(1)</sup> Specific gravity	External temperature <sup>(2)</sup> Line pressure % CO2 % N2	Molecular weight of air
	NX 19 Mod	Sample temperature data from meter (RTD) <sup>(1)</sup>	External temperature <sup>(2)</sup> Line pressure % CO2 % N2	
	NX 19 3h	Sample temperature data from meter (RTD) <sup>(1)</sup> Specific gravity Calorific value	External temperature <sup>(2)</sup> Line pressure % CO2 % N2	Molecular weight of air
	SGERG-88	Sample temperature data from meter (RTD) <sup>(1)</sup> Calorific value	External temperature <sup>(2)</sup> Line pressure % CO2 % H2 % N2	
Base compressibility	NX 19	Specific gravity	% CO2 % N2	Molecular weight of air Base temperature Base pressure
	NX 19 Mod	Specific gravity	% CO2 % N2	Base temperature Base pressure
	NX 19 3h	Specific gravity Calorific value	% CO2 % N2	Molecular weight of air Base temperature Base pressure
	SGERG-88	Calorific value	% CO2 % H2 % N2	Base temperature Base pressure
Calorific Value	AGA-5	Line density Specific gravity	% CO % CO2 % H2 % N2	
Wobbe Index		Specific gravity Calorific value		

**Table 2-3: Gas measurement when the primary process variable is molecular weight (continued)**

Process variable to be reported		Process data provided by the SGM	Required process data from external devices	Required user-specified values
Energy Flow	Mass units	Line density Calorific value	Mass flow rate (direct input or calculated)	
	Volume units	Calorific value	Volume flow rate (direct input or calculated)	

(1) Used when you want process variables to represent the gas in the measurement chamber.

(2) Used when you want process variables to represent the gas at the location of the temperature probe.

**Table 2-4: Gas measurement when the primary process variable is relative density**

Process variable to be reported		Process data provided by the SGM	Required process data from external devices	Required user-specified values
Relative density		Relative density		
Base density		Relative density		Base density of air
Line density		Temperature data from meter (RTD) <sup>(1)</sup> Base density Line compressibility Base compressibility	External temperature <sup>(2)</sup> Line pressure	Base temperature Base pressure
Line compressibility		Temperature data from meter (RTD) <sup>(1)</sup> Relative density	External temperature <sup>(2)</sup> Line pressure % CO2 % H2 % N2	
Base compressibility		Relative density	% CO2 % H2 % N2	Base temperature Base pressure

(1) Used when you want process variables to represent the gas in the measurement chamber.

(2) Used when you want process variables to represent the gas at the location of the temperature probe.

## 2.4 Equations used to calculate specific gravity, molecular weight, and relative density

### 2.4.1 Primary process variable = specific gravity

The following equations are used when the primary process variable is specific gravity.

#### Specific gravity

$$SG = K0 + (K1 \times \tau) + (K2 \times \tau^2)$$

**SG** Specific gravity of process gas

**K0, K1, K2** Calibration factors from the on-site calibration. If a two-point calibration was performed, K1 is set to 0.

**τ** Sensor time period (microseconds)

#### Molecular weight calculated from specific gravity

$$MW_{Gas} = SG_{Gas} \times MW_{Air}$$

**MW<sub>Gas</sub>** Molecular weight of process gas (g/mol)

**SG** Specific gravity of process gas

**MW<sub>Air</sub>** Molecular weight of air (user-specified; default = 28.96469 g/mol)

## 2.4.2 Primary process variable = molecular weight

The following equations are used when the primary process variable is molecular weight.

#### Molecular weight

$$MW = K0 + (K1 \times \tau) + (K2 \times \tau^2)$$

**MW** Molecular weight of process gas

**K0, K1, K2** Calibration factors from the on-site calibration. If a two-point calibration was performed, K1 is set to 0.

**τ** Sensor time period (microseconds)

#### Specific gravity calculated from molecular weight

$$SG = \frac{MW_{Gas}}{MW_{Air}}$$

**SG** Specific gravity of process gas

**MW<sub>Gas</sub>** Molecular weight of process gas (g/mol)

**MW<sub>Air</sub>** Molecular weight of air (user-specified; default = 28.96469 g/mol)

## 2.4.3 Primary process variable = relative density

The following equation is used when the primary process variable is relative density.

#### Relative density

$$RD = K0 + (K1 \times \tau) + (K2 \times \tau^2)$$

**RD** Relative density of process gas

**K0, K1, K2** Calibration factors from the on-site calibration. If a two-point calibration was performed, K1 is set to 0.

**τ** Sensor time period (microseconds)



## 3 Quick start

### 3.1 Power up the transmitter

The transmitter must be powered up for all configuration and commissioning tasks, or for process measurement.

#### Procedure

1. Ensure that all transmitter and sensor covers and seals are closed.



#### WARNING

To prevent ignition of flammable or combustible atmospheres, ensure that all covers and seals are tightly closed. For hazardous area installations, applying power while housing covers are removed or loose can cause an explosion.

2. Turn on the electrical power at the power supply.  
The transmitter will automatically perform diagnostic routines. During this period, Alert 009 is active. The diagnostic routines should complete in approximately 30 seconds.

#### Postrequisites

Although the sensor is ready to receive process fluid shortly after power-up, the electronics can take up to 10 minutes to reach thermal equilibrium. Therefore, if this is the initial startup, or if power has been off long enough to allow components to reach ambient temperature, allow the electronics to warm up for approximately 10 minutes before relying on process measurements. During this warm-up period, you may observe minor measurement instability or inaccuracy.

### 3.2 Check meter status

Check the meter for any error conditions that require user action or that affect measurement accuracy.

#### Procedure

1. Wait approximately 10 seconds for the power-up sequence to complete.  
Immediately after power-up, the transmitter runs through diagnostic routines and checks for error conditions. During the power-up sequence, Alert A009 is active. This alert should clear automatically when the power-up sequence is complete.
2. Check the status LED on the transmitter.

**Table 3-1: Transmitter status reported by status LED**

LED state	Description	Recommendation
Green	No alerts are active.	Continue with configuration or process measurement.
Yellow	One or more low-severity alerts are active.	A low-severity alert condition does not affect measurement accuracy or output behavior. You can continue with configuration or process measurement. If you choose, you can identify and resolve the alert condition.

**Table 3-1: Transmitter status reported by status LED (continued)**

LED state	Description	Recommendation
Flashing yellow	Calibration in progress, or Known Density Verification in progress.	The measurement can fluctuate during the calibration process or change as a result of the calibration process. The alert will clear when the calibration is complete. Check the calibration results before continuing.
Red	One or more high-severity alerts are active.	A high-severity alert condition affects measurement accuracy and output behavior. Resolve the alert condition before continuing.

### Related information

[View and acknowledge status alerts](#)  
[Status alerts, causes, and recommendations](#)

## 3.3 Make a startup connection to the transmitter

For all configuration tools except the display, you must have an active connection to the transmitter to configure the transmitter.

### Procedure

Identify the connection type to use, and follow the instructions for that connection type in the appropriate appendix. Use the default communications parameters shown in the appendix.

Communications tool	Connection type to use	Instructions
ProLink III	Modbus/RS-485 HART/Bell 202	<a href="#">Using ProLink III with the transmitter</a>
Field communicator	HART/Bell 202	<a href="#">Using the field communicator with the transmitter</a>

### Postrequisites

(Optional) Change the communications parameters to site-specific values.

ProLink III	Device Tools → Configuration → Communications
Field communicator	Configure → Manual Setup → HART → Communications

### Important

If you are changing communications parameters for the connection type that you are using, you will lose the connection when you write the parameters to the transmitter. Reconnect using the new parameters.

# 4 Introduction to configuration and commissioning

## 4.1 Default values

Default values for your SGM meter are configured at the factory.

### Important

Default values are based on your purchase order options. Therefore, the default values described in the following tables may not be the factory default values configured for your system. For absolute accuracy, refer to the configuration sheet that was shipped with your meter.

### 4.1.1 SGM default mA scaling values

**Table 4-1: Primary variables**

Variable	Default 4 mA	Default 20 mA
Specific gravity for calibration range 1	0	0.4
Specific gravity for calibration range 2	0	0.4
Specific gravity for calibration range 3	0	0.4
Specific gravity for calibration range 4	0	0.4
Molecular weight for calibration range 1	0 g/mol	28.96469 g/mol
Molecular weight for calibration range 2	0 g/mol	28.96469 g/mol
Molecular weight for calibration range 3	0 g/mol	28.96469 g/mol
Molecular weight for calibration range 4	0 g/mol	28.96469 g/mol
Sensor time period	400 us	1200 us

**Table 4-2: Derived variables**

Variable	Default 4 mA	Default 20 mA
Base density	0.000 g/cm <sup>3</sup>	0.400 g/cm <sup>3</sup>
Calorific value	20 MJ/Nm <sup>3</sup>	60 MJ/Nm <sup>3</sup>
Wobbe index	20 MJ/Nm <sup>3</sup>	60 MJ/Nm <sup>3</sup>
Sample temperature	-50.000°C -58°F	200.000°C 392°F
Drive gain	0.000 %	100.000 %
External temperature	-50.000°C -58.00000°F	200.000°C 392.00000°F

**Table 4-2: Derived variables (continued)**

Variable	Default 4 mA	Default 20 mA
External pressure	0.000 PSIG	1450.377 PSIG
Line density	0 g/cm <sup>3</sup>	0.4 g/cm <sup>3</sup>
User-defined calculation output	0	100
%CO <sub>2</sub>	0 %	100.00 %
%N <sub>2</sub>	0 %	100.00 %
%H <sub>2</sub>	0 %	100.00 %
%CO	0 %	100.00 %

**Table 4-3: Concentration measurement enabled**

Variable	Default 4 mA	Default 20 mA
Gas purity concentration for curve 1	00.00 %	100.00 %
Gas purity concentration for curve 2	00.00 %	100.00 %
Gas purity concentration for curve 3	00.00 %	100.00 %
Gas purity concentration for curve 4	00.00 %	100.000 %

**Table 4-4: Flow input enabled**

Variable	Default 4 mA	Default 20 mA
Mass flow rate (calculated)	-200.00 g/sec	200.00 g/sec
Mass flow rate (external)	-200.00 g/sec	200.00 g/sec
Volume flow rate (calculated)	-0.42378 SCFM	0.42378 SCFM
Volume flow rate (external)	-0.2 l/sec	0.2 l/sec

**Table 4-5: SGM default variables**

Default variable	Output option A	Output options B and C
Primary Variable (PV), mA1	Sample Temperature	<ul style="list-style-type: none"> <li>Specific Gravity for Calibration Set 1</li> <li>Molecular Weight for Calibration Set 1</li> <li>Relative Density</li> </ul>
Secondary Variable (SV), mA2	Time Period B	Sample Temperature
Tertiary Variable (TV)	<ul style="list-style-type: none"> <li>Specific Gravity for Calibration Set 1</li> <li>Molecular Weight for Calibration Set 1</li> <li>Relative Density</li> </ul>	Sensor Time Period
Quaternary Variable (QV)	Drive Gain	Drive Gain



## 4.2 Enable access to the off-line menu of the display

ProLink III	Device Tools → Configuration → Transmitter Display → Display Security
Field communicator	Configure → Manual Setup → Display → Display Menus → Offline Menu

By default, access to the off-line menu of the display is enabled. If it is disabled, you must enable it if you want to use the display to configure the transmitter.

### Restriction

You cannot use the display to enable access to the off-line menu. You must make a connection from another tool.

## 4.3 Disable HART security

If you plan to use HART protocol to configure the device, HART security must be disabled. HART security is disabled by default, so you may not need to do this.

### Prerequisites

- Strap wrench
- 3 mm hex key

### Procedure

1. Power down the meter.
2. Using the strap wrench, loosen the grub screws and remove the transmitter end-cap.

Figure 4-1: Transmitter with end-cap removed

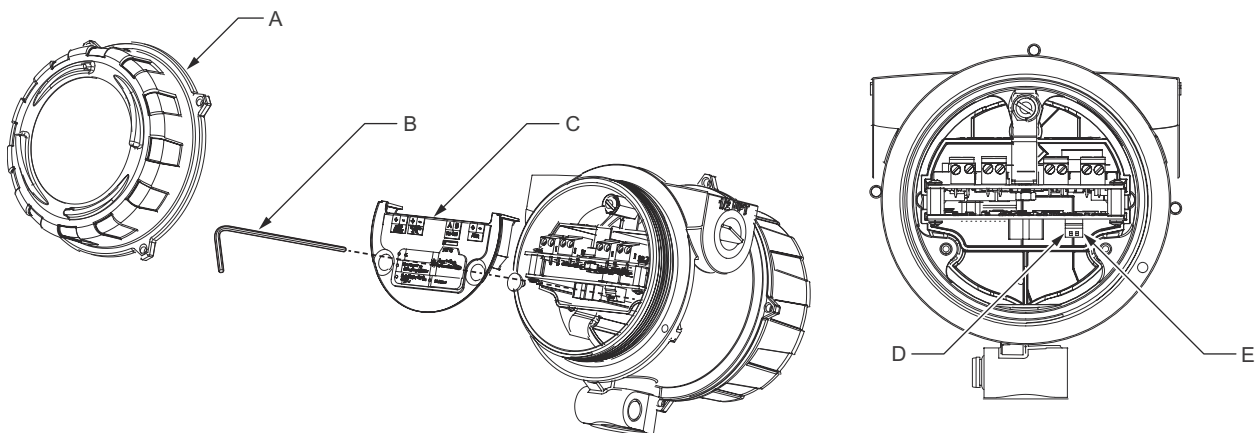

- A. Transmitter end-cap
- B. 3 mm hex key
- C. Safety spacer
- D. HART security switch
- E. Unused

3. Using the hex key, remove the safety spacer.

4. Move the HART security switch to the OFF position (up).

The HART security switch is the switch on the left.

5. Replace the safety spacer and end-cap.
6. Power up the meter.

## 4.4 Set the HART lock

If you plan to use a HART connection to configure the device, you can lock out all other HART masters. If you do this, other HART masters will be able to read data from the device but will not be able to write data to the device.

### Restriction

HART lock is only available:

- When you are using a field communicator or AMS
- With a HART 7 host

### Procedure

1. Choose **Configure** → **Manual Setup** → **Security** → **Lock/Unlock Device**.
2. If you are locking the meter, set **Lock Option** as desired.

Option	Description
Permanent	Only the current HART master can make changes to the device. The device will remain locked until manually unlocked by a HART master. The HART master can also change <b>Lock Option</b> to Temporary.
Temporary	Only the current HART master can make changes to the device. The device will remain locked until manually unlocked by a HART master, or a power-cycle or device reset is performed. The HART master can also change <b>Lock Option</b> to Permanent.
Lock All	No HART masters are allowed to make changes to the configuration. Before changing <b>Lock Option</b> to Permanent or Temporary, the device must be unlocked. Any HART master can be used to unlock the device.

### Postrequisites

To avoid future confusion or difficulties, ensure that the device is unlocked after you have completed your tasks.

## 4.5 Restore the factory configuration

The SGM is a field-configured device. Therefore, attempts to restore the factory configuration will result in an error since no factory configuration is loaded into the SGM electronics.

## 5 Purging and calibration

### 5.1 On-site setup requirements

The SGM is shipped with an empty reference chamber and no calibration factors. The SGM cannot be factory calibrated. Instead, you must perform calibration in the field using one of two on-site setup procedures. A setup procedure involves purging and filling the reference chamber with your process gas, then using known calibration gases.

#### Related information

- [Prepare for SGM purging and calibration](#)
- [Purge and purge-cycle the SGM device](#)
- [Calibrate the SGM device](#)
- [Review data for all calibrations](#)
- [Select the active calibration](#)

### 5.2 Prepare for SGM purging and calibration

Before you begin these procedures, you must:

- Know the primary process variable that you want to use. In other words, you must know whether the meter will operate as a specific gravity meter, a molecular weight meter, or a relative density meter.
- Know if you need a two-point or three-point calibration. Most applications require a two-point calibration. For a few exceptions, a three-point calibration may be required.
- Prepare the calibration gases.
- Know the appropriate control pressure.
- Be able to control sample pressure and vent pressure.

#### Related information

- [Three-point calibration](#)

#### 5.2.1 Primary process variable: specific gravity, molecular weight, or relative density

The SGM can operate as a specific gravity meter, a molecular weight meter, or a relative density meter. Your choice determines the set of process variables that the meter can report, the methods used to measure and calculate them, and the data that you must supply during setup and configuration.

The primary process variable — specific gravity, molecular weight, or relative density — needs to be specified as part of the order. However, you can change the primary process variable during calibration.

#### Related information

- [Primary process variable and available gas process variables](#)
- [Primary process variable, gas process variables, and required data](#)

## 5.2.2 Two-point calibration vs. three-point calibration

Your choice of two-point calibration or three-point calibration depends on how many process gases you are using.

<b>Two-point calibration</b>	Two gases are used for calibration. Standard and most common applications require only two calibration points to get the best accuracy. A two-point calibration produces two calibration factors: K0 and K2. K1 is set to 0.
<b>Three-point calibration</b>	Three gases are used for calibration. Three-point calibrations are less common. For more information, see <a href="#">Three-point calibration</a> .

### Related information

[Three-point calibration](#)

## 5.2.3 Calibration gases

The calibration gases should match the main constituents of your process gas. The gases must cover the lower and upper SG/MW range of the process gas and have similar compressibility characteristics.

### Gas types and requirements

Analytical calibration gases are specified by purity grade or number of 9's. "High purity" or "4.5 nines (99.995%)" grades are good choices for calibrating the SGM.

For example, if the SGM is measuring the specific gravity of natural gas, use pure nitrogen and pure methane as calibration gases.

**Table 5-1: Examples of calibration gases**

Application	Two-point calibration gases
Natural gas	Methane and nitrogen
Hydrogen purity	Hydrogen and nitrogen
Fuel to air ratio	Methane and propane

### Equipment requirements

- Cylinders must have a gauge regulator and hose.
- The hose needs to have a 0.25 in (6.4 mm) Swagelok® female connector.
- The minimum gas bottle size for each of the calibration gases should be no less than 4.5 gallons (17 liters) at a 20% higher of nominal pressure at the outlet of the regulator depending on the application.

Most gas suppliers can provide these items.

---

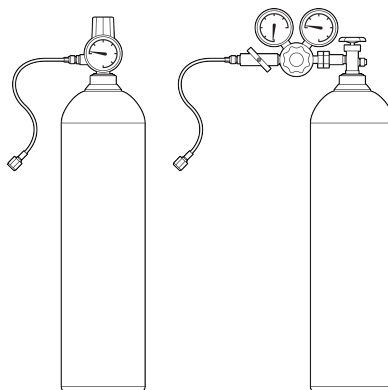
**Figure 5-1: Examples of cylinders with pressure regulators, hoses, and compression fittings**



---

**Data entry for gas calibration**

During calibration, you will be required to enter data for each calibration gas:

- If the SGM is operating as a specific gravity meter, you must enter the specific gravity of the gas. During calibration, you must be able to flow each calibration gas through the meter in the order of their specific gravity, lowest to highest.
- If the SGM is operating as a relative density meter, you must enter the relative density of the calibration gas.
- If the SGM is operating as a molecular weight meter, you must enter the molecular weight of the gas.

## 5.2.4 Pressure

A meter with the sampling conditioning system includes a pressure regulator with indicator that:

- Controls the inlet sample pressure
- Allows you to verify sample pressure

---

**Note**

All SGM models come with an included pressure gauge that identifies only the reference chamber pressure that is used for pressure and compressibility compensation.

For SGM models without the sampling conditioning system, a pressure regulator with indicator must be installed by the customer.

The pressure in the system must meet the following requirements:

- The maximum sample inlet pressure (the pressure regulator with gauge in [Pressure](#)) for the different SGM models should not exceed:

SGM model	Pressure rating
SGM2, SGM3 (without pressure regulator)	122 psia (8.41 bara)
SGM4 (with pressure regulator)	1,450 psia (100 bara)

- Reference chamber maximum pressure: 101 psia (6.96 bara)

## Determine the reference chamber pressure

The reference chamber pressure must be appropriate to your application. You must know the desired reference chamber pressure before you begin the purge and calibration process. The reference chamber pressure also affects the inlet sample supply pressure and the outlet vent pressure that you must maintain in the system.

### Guidelines for reference chamber pressure

Use the following guidelines for reference chamber pressure:

- Between 17 psia (1.17 bara) and 101 psia (7 bara), at 68 °F (20 °C)
- Less than the inlet sample pressure by 15% to 25%
- Greater than the outlet vent pressure

These pressure settings work for most applications. Use them as starting point, or use them to calculate reference chamber pressure using data that is specific to your process.

### Related information

[Calculate measurement errors using reference chamber pressure](#)

## 5.2.5 Multiple calibrations

The SGM can store calibrations for up to four different process gases or ranges. Each calibration is generated by an independent calibration procedure and contains an independent set of calibration coefficients. This feature allows you to switch between process gases or ranges without recalibrating the device.

If you plan to use more than one calibration:

- Perform all calibrations using the same measurement option: specific gravity, molecular weight, or relative density.
- Set calibrations as either two-point calibrations or three-point calibrations.
- Complete each calibration before beginning the next calibration.
- Choose to add calibrations at a later time. You do not need to perform all calibrations at the same time.

---

### Important

It is possible to use a different reference chamber pressure for each calibration. If you do, change the reference chamber pressure in the meter whenever you change the active calibration. If you do not change the reference chamber pressure to match the active calibration, measurement accuracy will be affected.

---

### Calibration ranges

- If you have a specific gravity meter, the meter will automatically calculate the specific gravity output variable for all four ranges during operation.
- If you have a molecular weight meter, the meter will automatically calculate the molecular weight output variable for all four ranges during operation.
- If you have a relative density meter, only one calibration is applied at a time. A control selects the active calibration.
- For specific gravity and molecular weight meters — energy, energy flow, compressibility, and Wobbe index are calculated only from the active calibration. Gas purity is automatically calculated for the associated

calibration (for example, Gas Purity Concentration for curve 4 automatically uses calibration range 4). Damping is applied only to the active variable.

## 5.3 Purge and purge-cycle the SGM device

Purging the SGM device prepares it for calibration by ensuring that the reference chamber is filled and sealed with appropriate process gas to the desired pressure.

### Prerequisites

- You must be able to flow process gas through the device.
- You must know the working pressure of your system and the desired reference chamber pressure.

Figure 5-2: Pictorial representation of a typical SGM installation

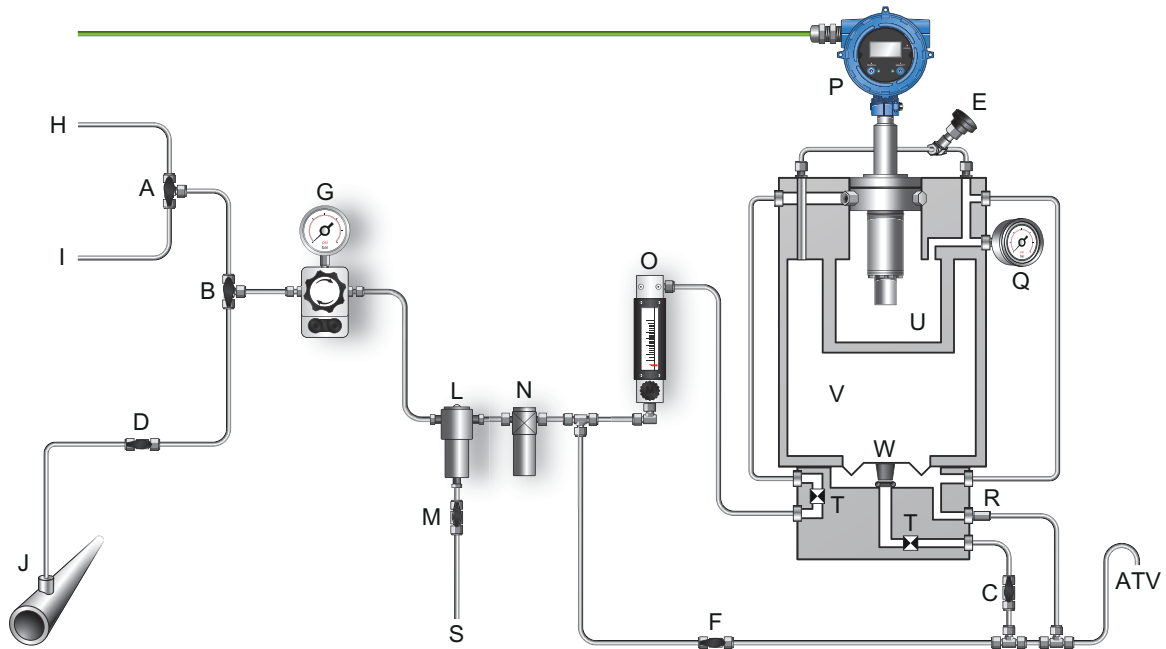

- A. Calibration gas selector three-way valve
- B. Process/Calibration gas selector three-way valve
- C. Outlet two-way valve
- D. Process gas inlet two-way valve
- E. Chamber fill valve
- F. Purge two-way valve
- G. Pressure regulator with gauge
- H. Calibration gas 1 inlet
- I. Calibration gas 2 inlet
- J. Process gas sampling point
- K. Tubing work (not shown in diagram)
- L. Coalescent filter
- M. Coalescent filter drain two-way valve
- N. Particle filter
- O. Flow meter
- P. Transmitter
- Q. Reference chamber pressure indicator
- R. Relief valve
- S. Drain
- T. Internal orifice restriction
- U. Measurement chamber
- V. Reference chamber
- W. Diaphragm

**ATV** Atmospheric Vent



## Procedure

1. Close the process gas inlet two-way valve (D), outlet valve (C), purge valve (F), and drain valves (M).
2. Set the process/calibration selector valve (B) to the Process Gas position.
3. Open the process gas inlet two-way valve (D).
4. Open the outlet valve (C).
5. Set the pressure regulator (G) to the working pressure of the system without exceeding 122 psia (8.41 bara).
6. Open the chamber filling valve (E).
7. Allow gas to flow for three minutes.
8. Close the outlet valve (C).
9. Observe the reference chamber pressure gauge (Q) until it reaches the desired pressure:
  - a) Close the process gas inlet two-way valve (D) and open the purge valve (F), allowing the gas to vent to atmospheric pressure.
10. Purge-cycle the device.
  - a) Close the purge valve (F) and open the process gas inlet two-way valve (D).
  - b) Observe the reference chamber pressure indicator (Q) until it reaches the desired control pressure, close the process gas inlet two-way valve (D) and open the purge valve (F).
  - c) Allow the gas to vent to atmospheric pressure.
  - d) Repeat this step for the required number of cycles, as determined by the following equation:

$$NumberPurgeCycles = \frac{21}{MaxRegulatorPressure}$$

11. Close the purge valve (F) and open the process gas inlet two-way valve (D).
12. When the reference chamber pressure reaches the desired value, close the chamber filling valve (E) and the process gas inlet valve (D) in preparation for flowing the calibration gases.

The reference chamber is now filled with the reference gas at the control pressure, and the SGM is ready to run the calibration gases.

---

### Important

After the reference chamber has been filled, do not open the chamber filling valve (N) again.

---

### Related information

[Functional view of the SGM](#)

## 5.4 Calibrate the SGM device

The SGM device must be calibrated for your process gas. The SGM leaves the factory uncalibrated and requires proper field calibration to generate calibration coefficients for your process gas.

### Prerequisites

- You must have completed the purge procedure, and the reference chamber must be filled with the reference gas to the appropriate pressure.

- You must know whether you want the device to operate as a specific gravity meter, a molecular weight meter, or a relative density meter.
- You must know if you want a two-point calibration or a three-point calibration. Most applications require a two-point calibration. In purity applications, a three-point calibration may be more appropriate. For more information, see [Three-point calibration](#).
- You must have identified all required calibration gases and know their specific gravity, molecular weight, or relative density.
- You must be prepared to flow all calibration gases through the device, at the appropriate sample pressure. In a typical application, the sample pressure should be approximately 20% greater than the reference chamber pressure.

### Related information

[Calibrate the SGM device using the display](#)

[Calibrate the SGM device using ProLink III](#)

[Calibrate the SGM device using a field communicator](#)

## 5.4.1 Calibrate the SGM device using the display

### Procedure

1. Read the Prerequisites in [Calibrate the SGM device](#) if you have not already done so.
2. Enter the **Off-Line Maintenance** menu and activate **SCROLL** until **OFF-LINE CAL** appears on the display, then activate **Select**.
3. When **CAL SG** appears, activate **Select**.
4. Set the measurement type for this device.
  - a) When **CAL TYPE** appears, activate **Select**, then scroll through the list of options.
  - b) When the desired option appears, activate **Select**, then store the selection.

Option	Description
Specific Gravity Meter	Gas density will be measured as specific gravity, and specific gravity will be used for calibration.
Molecular Weight Meter	Gas density will be measured as molecular weight, and molecular weight will be used for calibration.
Relative Density Meter	Gas density will be measured as relative density, and relative density will be used for calibration.

5. Set the calibration type (calibration format).
  - a) Activate **SCROLL** until **CAL PTS** appears.
  - b) Activate **Select**, then scroll through the list of options.
  - c) When the desired option appears, activate **Select**, then store the selection.

Option	Description
2-Point Calibration	Appropriate for gases with two main constituents. Requires two calibration gases.
3-Point Calibration	Appropriate for gases with three main constituents. Use only if recommended by customer support. For more information, see <a href="#">Three-point calibration</a> .

6. Select the number of the calibration that you want to perform.
  - a) When **CAL NUMBR** appears, activate **Select**, then scroll through the list of options.
  - b) When the desired option appears, activate **Select**, then store the selection.

The device can store up to four independent calibration ranges. All calibrations must have the same calibration type (2-point or 3-point). Each calibration can use different calibration gases.

7. Set the low-density calibration point. See [Figure 5-2](#).
  - a) Connect the lower calibration gas to the calibration gas inlet 1 (H).
  - b) Set the pressure regulator on the lower calibration gas tank to the appropriate sample pressure for your installation.

---

#### Note

Make sure the process gas inlet valve (D) is closed.

---

- c) Set the gas selector valve (A) to the calibration gas inlet 1 position and open the outlet valve (C).
  - d) Set the process/calibration selector valve (B) to the calibration position.
  - e) Activate **SCROLL** until **ENTER GAS LOW** appears, then activate **SELECT**.
  - f) Enter the specific gravity, molecular weight, or relative density of the calibration gas that is flowing through the system and store the value by activating both **SCROLL** and **SELECT** at same time until the previous menu appears.
  - g) Activate **SCROLL**.
  - h) When **CAL GAS LOW** appears, activate **Select** to start the calibration.
  - i) During the calibration, activate **SCROLL** to observe the **Sensor Time Period** and **Stability** values during the calibration.
  - j) Wait between 3 to 15 minutes for the system to stabilize. When **Stability** is **Good**, activate **Select**.  
If measurement does not stabilize after 30 minutes, activate **SCROLL** to abort the calibration.
  - k) Activate **Select** again to accept the calibration value.
  - l) As the gas flows, select the **Start** button and observe the **Sensor Time Period** and **Stability** values.
8. Set the high-density calibration point.
  - a) Connect the higher calibration gas to the calibration gas 2 inlet (I).
  - b) Set the pressure regulator on the higher calibration gas to the appropriate sample pressure for your installation.

- c) Set the calibration gas selector valve (A) to the calibration gas 2 inlet (I) position. The process gas inlet valve (D) must remain closed.
- d) Activate **SCROLL** until **ENTER GAS HIGH** appears, then activate **Select**.
- e) Enter the specific gravity, molecular weight, or relative density of the calibration gas that is flowing through the system and store the value by activating both **SCROLL** and **SELECT** at same time until the previous menu appears.
- f) Activate **SCROLL**
- g) When **CAL GAS HIGH** appears, activate **Select** to start the calibration.
- h) During the calibration, activate **SCROLL** to observe the **Sensor Time Period** and **Stability** values during the calibration.
- i) Wait between 3 to 15 minutes for the system to stabilize. When **Stability** is **Good**, activate **Select**.  
If measurement does not stabilize after 30 minutes, activate **SCROLL** to abort the calibration.
- j) Activate **Select** again to accept the calibration value.
- k) As the gas flows, select the **Start** button and observe the **Sensor Time Period** and **Stability** values.
- l) Disconnect the lower calibration gas.

9. Activate **SCROLL** until **CALC K VAL** appears, then activate **Select**.

The meter automatically calculates the calibration factors from the stored data.

10. View the calibration factors.

- a) When **RESULT DISPLAY** appears, activate **Select**.
- b) Activate **SCROLL** to view the calibration factors and data.

Results are displayed in this order:

- The specific gravity, molecular weight, or relative density used to calculate the K0 calibration factor
- The time period used to calculate the K0 calibration factor
- The specific gravity, molecular weight, or relative density used to calculate the K1 calibration factor (3-point calibrations only)
- The time period used to calculate the K1 calibration factor (3-point calibrations only)
- The specific gravity, molecular weight, or relative density used to calculate the K2 calibration factor
- The time period used to calculate the K2 calibration factor
- The K0 calibration factor
- The K1 calibration factor (3-point calibrations only), displayed in exponential format
- The K2 calibration factor, displayed in exponential format

- c) When **Exit** appears, activate **Select**.
- 11. Select the calibration to be used for measurement.
  - a) Activate **SCROLL** until **CAL ACTIVE** appears.
  - b) Activate **Select**, then scroll through the list of options.
  - c) When the desired option appears, activate **Select**, then store the selection.
- 12. Optional: To add a calibration, return to the first step and repeat this procedure.
- 13. The SGM is ready to be used. Shut off the calibration gas regulators and set the process/calibration selector valve (B) to the process gas position and open the process gas inlet valve (D) to let process gas flow through the system and be measured.

**Related information**

[Functional view of the SGM](#)

[Verify the SGM calibration](#)

## 5.4.2 Calibrate the SGM device using ProLink III

**Procedure**

- 1. Read the Prerequisites in [Calibrate the SGM device](#) if you have not already done so.
- 2. Choose **Device Tools** → **Calibration** → **Gas Calibration**.

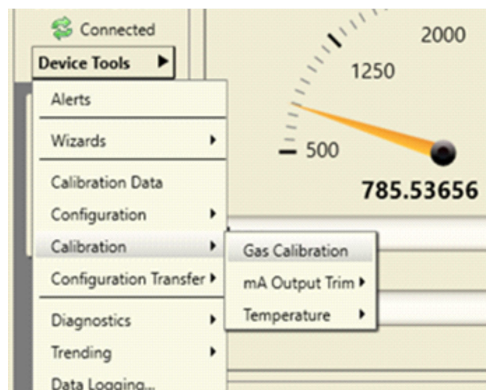

- 3. Set the measurement type for this device.

Option	Description
Specific Gravity Meter	Gas density will be measured as specific gravity, and specific gravity will be used for calibration.
Molecular Weight Meter	Gas density will be measured as molecular weight, and molecular weight will be used for calibration.
Relative Density Meter	Gas density will be measured as relative density, and relative density will be used for calibration.

- 4. Set the calibration type (calibration format).

Option	Description
2-Point Calibration	Appropriate for gases with two main constituents. Requires two calibration gases.
3-Point Calibration	Appropriate for gases with three main constituents. Use only if recommended by customer support. For more information, see <a href="#">Three-point calibration</a> .

**Molecular Weight Calibration**

**Important**  
Before beginning calibration, the reference chamber must be purged, filled with the reference gas to the control pressure, and sealed. See the configuration manual for more information.

**Step 1: Set Measurement Type to the core process variable to be measured by the meter.**

Molecular Weight Meter

- Molecular Weight Meter
- Relative Density Meter
- Specific Gravity Meter

**Step 2: Set Calibration Type to the number of calibration points (applies to all calibrations).**

2-Point Calibration

3-Point Calibration

5. Select **Next**.

6. Select the number of the calibration that you want to perform (CAL 1, CAL 2, CAL 3, or CAL 4).

The device can store up to four independent calibration ranges. All calibrations must have the same calibration type (2-point or 3-point). Each calibration can use different calibration gases.

7. Enter data for each calibration gas.

- Select the calibration gas from the list for **Calibration Gas Low** and **Calibration Gas High**. If it is not listed, select Other.
- Enter the specific gravity, molecular weight, or relative density of the calibration gas for **Calibration Gas Low** and **Calibration Gas High**.

**Molecular Weight Calibration**

**Step 3: Set Calibration Number to the number of the calibration that you are going to perform.**

CAL 1

**Step 4: Enter calibration gas data.**

	Gas	Molecular Weight
Calibration Gas Low	Methane	16.04300 g/mol
Calibration Gas High	Air	29.96500 g/mol

- c) Select **Next**.

**Tip**

Enter the calibration gases in order of density, from lowest to highest. This allows heavier gases to replace lighter gases.

- 8. Set the low-density calibration point. See [Figure 5-2](#).
  - a) Connect the lower calibration gas to the calibration gas inlet 1 (H).
  - b) Set the pressure regulator on the lower calibration gas tank to the appropriate sample pressure for your installation.

**Note**

Make sure the process gas inlet valve (D) is closed.

- c) Set the process/calibration gas valve (B) to the calibration position.
- d) Set the calibration gas selector valve (A) to the calibration gas inlet 1 position and open the outlet valve (C).
- e) As the gas flows, select the **Start** button and observe the **Live Sensor Time Period** and **Stability** values.

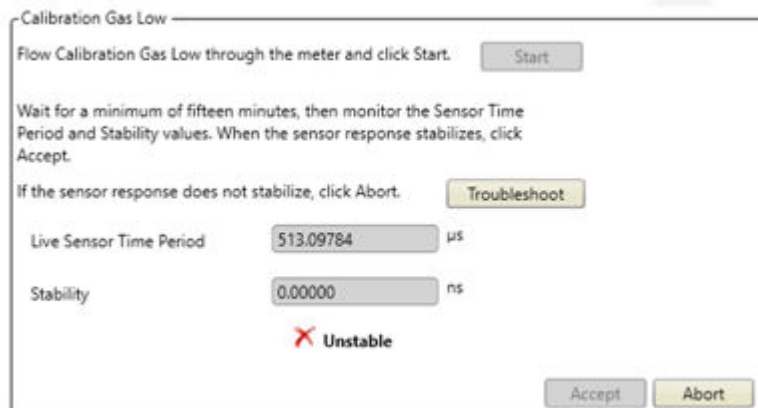

- f) Wait between 3 to 15 minutes for the system to stabilize. When **Stability** is **Good**, select **Accept** or **Next**.

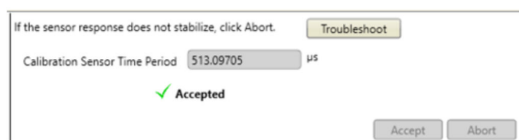

If measurement does not stabilize after 30 minutes, select **Abort** and troubleshoot the problem.

- g) Disconnect the lower calibration gas.
- 9. Set the high-density calibration point.
  - a) Connect the higher calibration gas to the calibration gas 2 inlet (I).

- b) Make sure the process/calibration selector valve (B) remains on the calibration position.
- c) As the gas flows, select the **Start** button and observe the **Sensor Time Period** and **Stability** values.

- d) Wait between 3 to 15 minutes for the system to stabilize. When **Stability** is Good, select **Accept** or **Next**.

If measurement does not stabilize after 30 minutes, select **Abort** and troubleshoot the problem.

- e) Disconnect the calibration gas.
10. Select **Next**.
  11. Review the results for this calibration.

12. Select **Finish** to save the results and exit, or select **Add Calibration** to add a calibration.

**Tip**

You can use **Add Calibration** to create a new set of calibration coefficients.

13. Set **Active Calibration** to the calibration to be used for measurement.

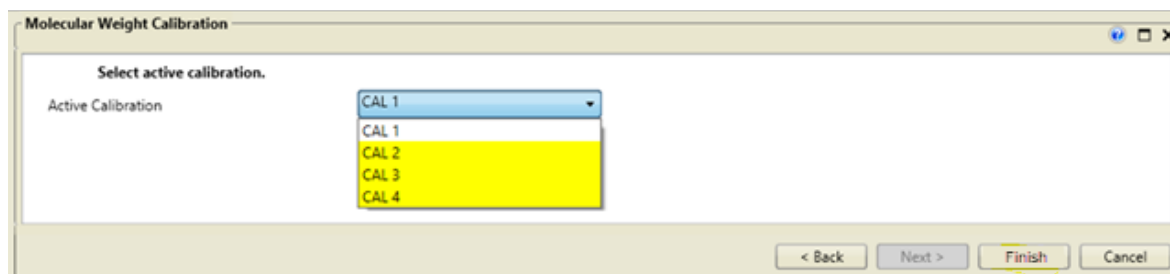

**Tip**

You can also set **Active Calibration** from the *Calibration Data* window. This allows you to change the calibration without going through the calibration wizard.

For 2-point calibrations, two calibration coefficients (K0 and K2) are calculated and used in measurement.

14. The SGM is ready to be used. Shut off the calibration gas regulators and set the process/calibration selector valve (B) to the process gas position and open the process gas inlet valve (D) to let process gas flow through the system and be measured.

**Related information**

[Functional view of the SGM](#)

[Verify the SGM calibration](#)

### 5.4.3 Calibrate the SGM device using a field communicator

**Procedure**

1. Read the Prerequisites in [Calibrate the SGM device](#) if you have not already done so.
2. Choose **Configure** → **Manual Setup** → **Measurements** → **Optional Setup** → **Gas Meter Calibration**.
3. Set the measurement type for this device and press **Send**.

Option	Description
Specific Gravity Meter	Gas density will be measured as specific gravity, and specific gravity will be used for calibration.
Molecular Weight Meter	Gas density will be measured as molecular weight, and molecular weight will be used for calibration.
Relative Density Meter	Gas density will be measured as relative density, and relative density will be used for calibration.

4. Set the calibration type (calibration format).

Option	Description
2-Point Calibration	Appropriate for gases with two main constituents. Requires two calibration gases.

Option	Description
3-Point Calibration	Appropriate for gases with three main constituents. Use only if recommended by customer support. For more information, see <a href="#">Three-point calibration</a> .

5. Select the number of the calibration that you want to perform and select **Send**.

---

**NOTICE**

If the information is not sent, then the calibration gas information is not set correctly and the corresponding K factors will not be calculated.

---

The device can store up to four independent calibration ranges. All calibrations must have the same calibration type (2-point or 3-point). Each calibration can use different calibration gases.

6. Enter data for each calibration gas.
  - a) Choose **Setup Calibration** and choose the calibration gas you are describing.
  - b) Select the calibration gas from the list for **Calibration Gas Low** and **Calibration Gas High**. If it is not listed, select **Other**.
  - c) Enter the specific gravity, molecular weight, or relative density of the calibration gas for **Calibration Gas Low** and **Calibration Gas High**.

---

**Tip**

Enter the calibration gases in order of density, from lowest to highest. This allows heavier gases to replace lighter gases.

---

7. Set the low-density calibration point. See [Figure 5-2](#).
  - a) Connect the lower calibration gas to the calibration gas inlet 1 (H).
  - b) Set the pressure regulator on the lower calibration gas tank to the appropriate sample pressure for your installation.

---

**Note**  
Make sure the process gas inlet valve (D) is closed.

---

  - c) Set the gas selector valve (A) to the calibration gas inlet 1 position and open the outlet valve (C).
  - d) Choose **Start Calibration** and choose the calibration gas you are using, then select **OK**.
  - e) As the gas flows, select the **Start** button and observe the **Sensor Time Period** and **Stability** values.
  - f) Wait between 3 to 15 minutes for the system to stabilize. When **Calibration Point** is **Good**, select **OK**.  
If measurement does not stabilize after 30 minutes, select **Abort** and troubleshoot the problem.
  - g) Close the calibration valve.
  - h) Disconnect the lower calibration gas.
8. Set the high-density calibration point.
  - a) Connect the higher calibration gas to the calibration gas 2 inlet (I).

- b) Set the pressure regulator on the lower calibration gas to the appropriate sample pressure for your installation.
- c) Set the calibration gas selector valve (A) to the calibration gas 2 inlet (I) position. The process gas inlet valve (D) must remain closed.
- d) Choose **Start Calibration** and choose the calibration gas you are using, then select **OK**.
- e) As the gas flows, select the **Start** button and observe the **Sensor Time Period** and **Stability** values.
- f) Wait between 3 to 15 minutes for the system to stabilize. When **Calibration Point** is **Good**, select **OK**.  
If measurement does not stabilize after 30 minutes, select **Abort** and troubleshoot the problem.
- g) Disconnect the calibration gas.

9. Choose **Results** to review the results for this calibration.

If you want to recalculate one or more of the calibration points, select **Back** and repeat the step.

10. Optional: To add a calibration, return to the first step and repeat this procedure.

---

**Restriction**

The additional calibrations must use the same measurement type and calibration type.

---

11. Choose **Configure** → **Manual Setup** → **Measurements** → **Gas Calibration** and set **Active Calibration** to the calibration to be used for measurement.

For 2-point calibrations, two calibration coefficients (K0 and K2) are calculated and used in measurement.

**Postrequisites**

To restore normal gas flow, set the process/calibration gas selector valve (B) to the process gas position and open the process gas inlet valve (D).

**Related information**

[Functional view of the SGM](#)

[Verify the SGM calibration](#)

## 5.4.4 Verify the SGM calibration

If one of the calibration point measurements does not stabilize within 30 minutes, abort the calibration and check for problems.

Typical problems include the following:

- The calibration gas is not flowing. Ensure that the pressure of the calibration gas is 15% to 25% higher than the reference chamber pressure, then check for obstructions in the gas path.
- The reference chamber or the gas path is leaking. Check for leakage.
- Verify that the purge valve and pipework connections are correct.

Depending on the problem, you may be able to restart the calibration at the abort point.

### Related information

[Check for leakage](#)

## 5.5 Review data for all calibrations

ProLink III	Device Tools → Calibration Data
Field communicator	Configure → Manual Setup → Calibration Factors

For all calibrations, you can review the gas data and sensor time period data that was used to calculate the calibration factors, and you can review the calibration factors.

## 5.6 Change the label for the active calibration

ProLink III	Device Tools → Calibration Data
Field communicator	Configure → Manual Setup → Calibration Factors

You can change the default calibration labels.

### Procedure

1. Select and delete the value in the **Calibration x Label** field.
2. Enter your preferred calibration label and press **Apply**.

## 5.7 Select the active calibration

ProLink III	Device Tools → Calibration Data → Active Calibration
Field communicator	Configure → Manual Setup → Measurements → Gas Calibration → Active Calibration

The SGM can store up to four calibrations. The active calibration specifies the calibration to be used for measurement.

### Important

Do not confuse the active calibration with the calibration being performed. For example, you may perform Calibration 4, and then choose to use Calibration 3 for measurement.

### Procedure

Set **Active Calibration** to the calibration you want to use for measurement.

### Related information

[Review data for all calibrations](#)

## 6 Configure measurement units using the display

---

### Restriction

The display allows you to configure measurement units, but does not support any other process measurement configuration. To access all process measurement parameters, you must use one of the following:

- ProLink III
  - Field communicator
- 

### 6.1 Configure measurement units using the display

The measurement unit parameters specify the units that will be used for process variables.

#### Procedure

1. Navigate to the *Off-Line Maintenance* menu and enter it.
2. Activate **Scroll** until **OFF-LINE CONFIG** appears, then activate **Select**.
3. When **CONFIG UNITS** appears, activate **Select**.
4. Set the units.
  - a) When the first process variable appears, activate **Select**.
  - b) Activate **Scroll** to scroll through the options for that process variable.
  - c) When the desired unit appears, activate **Select**.
  - d) Activate **Select** to store your choice.
  - e) Repeat until you have set measurement units for all process variables.
5. When **EXIT** appears, activate **Select** to return to the higher-level menu.



# 7 Configure process measurement using ProLink III

## 7.1 Configure specific gravity, molecular weight, or relative density parameters using ProLink III

These parameters control the measurement of the primary process variable.

### Related information

[Configure Damping using ProLink III](#)

[Configure the molecular weight of air using ProLink III](#)

### 7.1.1 Configure Damping using ProLink III

ProLink III	Device Tools → Configuration → Process Measurement → Specific Gravity → Damping Device Tools → Configuration → Process Measurement → Molecular Weight → Damping Device Tools → Configuration → Process Measurement → Relative Density → Damping
-------------	---

**Damping** controls the amount of damping that will be applied to the primary process variable: specific gravity, molecular weight, or relative density.

Damping is used to smooth out small, rapid fluctuations in process measurement. **Damping Value** specifies the time period (in seconds) over which the transmitter will spread changes in the process variable. At the end of the interval, the internal value will reflect 63% of the change in the actual measured value.

---

#### Tip

Damping affects all process variables that are calculated from the primary process variable: specific gravity, molecular weight, or relative density.

---

#### Procedure

Set **Damping** to the value you want to use.

The default value is 0 seconds. The range is 0 to 440 seconds.

### Interaction between Damping and Added Damping

When the mA Output is configured to report the primary process variable (specific gravity, molecular weight, or relative density), both **Damping** and **Added Damping** are applied to the reported value.

**Damping** controls the rate of change in the value of the process variable in transmitter memory. **Added Damping** controls the rate of change reported via the mA Output.

If **mA Output Process Variable** is set to Specific Gravity, Molecular Weight, or Relative Density, and both **Damping** and **Added Damping** are set to non-zero values, the primary process variable damping is applied first, and the added damping calculation is applied to the result of the first calculation. This value is reported over the mA Output.

## 7.1.2 Configure the molecular weight of air using ProLink III

ProLink III	<a href="#">Device Tools</a> → <a href="#">Configuration</a> → <a href="#">Process Measurement</a> → <a href="#">Specific Gravity</a> → <a href="#">Molecular Weight of Air</a> <a href="#">Device Tools</a> → <a href="#">Configuration</a> → <a href="#">Process Measurement</a> → <a href="#">Molecular Weight</a> → <a href="#">Molecular Weight of Air</a> <a href="#">Device Tools</a> → <a href="#">Configuration</a> → <a href="#">Process Measurement</a> → <a href="#">Relative Density</a> → <a href="#">Molecular Weight of Air</a>
-------------	---

The molecular weight of air is required for several different gas measurements. For most applications, the default value can be used.

### Procedure

Set **Molecular Weight of Air** to the value to be used in your application.

The default value is 28.95459 g/mol. This value is appropriate for most applications.

## 7.2 Configure temperature measurement using ProLink III

The temperature measurement parameters control how temperature is measured and reported.

### Related information

[Configure Temperature Unit using ProLink III](#)

[Configure Temperature Damping using ProLink III](#)

[Configure Temperature Input using ProLink III](#)

### 7.2.1 Configure Temperature Unit using ProLink III

ProLink III	<a href="#">Device Tools</a> → <a href="#">Configuration</a> → <a href="#">Process Measurement</a> → <a href="#">Sample Temperature</a> → <a href="#">Temperature Unit</a>
-------------	--

**Temperature Unit** specifies the unit that will be used for temperature measurement.

### Procedure

Set **Temperature Unit** to the option you want to use.

The default setting is Degrees Celsius.

### Options for Temperature Measurement Unit

The transmitter provides a standard set of units for **Temperature Measurement Unit**. Different communications tools may use different labels for the units.

Unit description	Label		
	Display	ProLink III	Field communicator
Degrees Celsius	°C	°C	degC
Degrees Fahrenheit	°F	°F	degF
Degrees Rankine	°R	°R	degR
Kelvin	°K	°K	Kelvin



## 7.2.2 Configure Temperature Damping using ProLink III

ProLink III	Device Tools → Configuration → Process Measurement → Sample Temperature → Temperature Damping
-------------	---

**Temperature Damping** controls the amount of damping that will be applied to the sample temperature value, when the on-board temperature data is used (RTD).

Damping is used to smooth out small, rapid fluctuations in process measurement. **Damping Value** specifies the time period (in seconds) over which the transmitter will spread changes in the process variable. At the end of the interval, the internal value will reflect 63% of the change in the actual measured value.

**Tip**

**Temperature Damping** affects all process variables, compensations, and corrections that use temperature data from the sensor.

**Procedure**

Enter the value you want to use for **Temperature Damping**.

The default value is 4.8 seconds. The range is 0 to 38.4 seconds.

**Tip**

- A high damping value makes the process variable appear smoother because the reported value changes slowly.
- A low damping value makes the process variable appear more erratic because the reported value changes more quickly.
- Whenever the damping value is non-zero, the reported measurement will lag the actual measurement because the reported value is being averaged over time.
- In general, lower damping values are preferable because there is less chance of data loss, and less lag time between the actual measurement and the reported value.

The value you enter is automatically rounded to the nearest valid value. Valid values for **Temperature Damping** are 0, 0.6, 1.2, 2.4, 4.8, ... 38.4.

## 7.2.3 Configure Temperature Input using ProLink III

ProLink III	Device Tools → Configuration → Process Measurement → Sample Temperature → Sample Temperature Source
-------------	---

**Procedure**

1. Choose the method to be used to supply temperature data, and perform the required setup.

Option	Description	Setup
Internal RTD temperature data	Temperature data from the on-board temperature sensor (RTD) is used.	<ol style="list-style-type: none"> <li>a. Set <b>Sample Temperature Source</b> to Internal RTD.</li> <li>b. Click <b>Apply</b>.</li> </ol>

Option	Description	Setup						
Polling	The meter polls an external device for temperature data. This data will be available in addition to the internal RTD temperature data.	<p>a. Set <b>Sample Temperature Source</b> to Poll for External Value.</p> <p>b. Set <b>Polling Slot</b> to an available slot.</p> <p>c. Set <b>Polling Control</b> to Poll as Primary or Poll as Secondary.</p> <table border="1"> <thead> <tr> <th>Option</th> <th>Description</th> </tr> </thead> <tbody> <tr> <td>Poll as Primary</td> <td>No other HART masters will be on the network. A field communicator is not a HART master.</td> </tr> <tr> <td>Poll as Secondary</td> <td>Other HART masters will be on the network. A field communicator is not a HART master.</td> </tr> </tbody> </table> <p>d. Set <b>External Device Tag</b> to the HART tag of the temperature device.</p> <p>e. Select <b>Apply</b>.</p>	Option	Description	Poll as Primary	No other HART masters will be on the network. A field communicator is not a HART master.	Poll as Secondary	Other HART masters will be on the network. A field communicator is not a HART master.
Option	Description							
Poll as Primary	No other HART masters will be on the network. A field communicator is not a HART master.							
Poll as Secondary	Other HART masters will be on the network. A field communicator is not a HART master.							
Digital communications	A host writes temperature data to the meter at appropriate intervals. This data will be available in addition to the internal RTD temperature data.	<p>a. Set <b>Sample Temperature Source</b> to Fixed Value or Digital Communications.</p> <p>b. Select <b>Apply</b>.</p> <p>c. Perform the necessary host programming and communications setup to write temperature data to the meter at appropriate intervals.</p>						

2. If you set up an external temperature:

a) Choose **Device Tools** → **Configuration** → **I/O** → **Inputs** → **External Inputs**.

b) In the **Sample Temperature Input** group, check or uncheck the checkboxes as desired.

If a checkbox is checked, the internal temperature is used for that measurement or calculation. If a checkbox is unchecked, the external temperature is used.

### Postrequisites

If you are using external temperature data, verify the external temperature value displayed in the **Inputs** group on the ProLink III main window.

### Need help?

If the value is not correct:

- For polling:
  - Verify the wiring between the meter and the external device.
  - Verify the HART tag of the external device.
- For digital communications:
  - Verify that the host has access to the required data.

- Verify that the host is writing to the correct register in memory, using the correct data type.

## 7.3 Configure the pressure input

Pressure data is required to calculate base density from line density. The meter does not measure pressure, so you must provide an external pressure input. You must use absolute pressure.

Pressure data is required for several different measurements. There are several different methods to obtain pressure data.

### Tip

A fixed value for temperature is not recommended. Using a fixed temperature value may produce inaccurate process data.

### Prerequisites

If you plan to poll an external device:

- The primary mA output must be wired to support HART communications.
- Ensure that the meter has the required polling slots available. The meter provides four polling slots, and they may be already in use. You may need to use a fixed value or digital communications for some external values. To check the current polling configuration, choose **Device Tools** → **Configuration** → **Polled Variables**.

### 7.3.1 Configure the pressure input using ProLink III

#### Procedure

1. Choose **Device Tools** → **Configuration** → **Process Measurement** → **Line Pressure**.
2. Set **Pressure Type** to match the pressure measurement from the external pressure device.

Option	Description
Absolute	The external pressure device reports absolute pressure.
Gauge	The external pressure device reports gauge pressure.

#### Restriction

If **Line Pressure Source** is set to Fixed, you cannot configure **Pressure Type**. You must enter the pressure value in the required form. To set **Pressure Type**, you may need to change the setting of **Line Pressure Source**.

The meter requires absolute pressure. If you select Gauge, the device will convert the input pressure value to the equivalent absolute pressure.

3. Set **Pressure Unit** to the unit used by the external pressure device.
4. Choose the method used to supply pressure data and perform the required setup.

Option	Description	Setup						
Polling	The meter polls an external device for pressure data.	<ol style="list-style-type: none"> <li>Set <b>Pressure Source</b> to Poll for External Value.</li> <li>Set <b>Polling Slot</b> to an available slot.</li> <li>Set <b>Polling Control</b> to Poll as Primary or Poll as Secondary.                             <table border="1" data-bbox="813 464 1414 716"> <thead> <tr> <th>Option</th> <th>Description</th> </tr> </thead> <tbody> <tr> <td>Poll as Primary</td> <td>No other HART masters will be on the network. A field communicator is not a HART master.</td> </tr> <tr> <td>Poll as Secondary</td> <td>Other HART masters will be on the network. A field communicator is not a HART master.</td> </tr> </tbody> </table> </li> <li>Set <b>External Device Tag</b> to the HART tag of the temperature device.</li> </ol>	Option	Description	Poll as Primary	No other HART masters will be on the network. A field communicator is not a HART master.	Poll as Secondary	Other HART masters will be on the network. A field communicator is not a HART master.
Option	Description							
Poll as Primary	No other HART masters will be on the network. A field communicator is not a HART master.							
Poll as Secondary	Other HART masters will be on the network. A field communicator is not a HART master.							
Digital communications	A host writes pressure data to the meter at appropriate intervals.	<ol style="list-style-type: none"> <li>Set <b>Pressure Source</b> to Fixed Value or Digital Communications.</li> <li>Perform the necessary host programming and communications setup to write pressure data to the meter at appropriate intervals.</li> </ol>						

**Postrequisites**

The current pressure value is displayed in the **External Pressure** field. Verify that the value is correct.

**Need help?**

If the value is not correct:

- Ensure that the external device and the meter are using the same measurement unit.
- For polling:
  - Verify the wiring between the meter and the external device.
  - Verify the HART tag of the external device.
- For digital communications:
  - Verify that the host has access to the required data.
  - Verify that the host is writing to the correct register in memory, using the correct data type.
- If necessary, apply an offset.

**Note**

Do not use the offset in conjunction with the fixed pressure value. Enter the adjusted value.

## 7.4 Configure gas compressibility measurement using ProLink III

ProLink III	Device Tools → Configuration → Process Measurement → Compressibility
-------------	--

Gas compressibility measurement is required for the following process variables: line density, calorific value, Wobbe index, and energy flow. Gas compressibility measurement can also be used to calculate compressibility as an independent process variable.

### Prerequisites

- You must know whether you will measure line compressibility and base compressibility or you will use fixed values.
- If you will use fixed values, you must know the line compressibility and base compressibility values for your application.
- If you will measure compressibility, you must be able to supply gas composition data to the meter, for the following constituents:
  - Carbon dioxide (CO<sub>2</sub>)
  - Nitrogen (N<sub>2</sub>)
  - Hydrogen (H<sub>2</sub>) (required only if you plan to measure compressibility according to SGERG 88)
- Gas composition must be measured in % by volume.
- If you plan to poll an external device for % CO<sub>2</sub>, % N<sub>2</sub>, or % H<sub>2</sub>, ensure that the meter has the required polling slots available. The meter provides four polling slots, and they may be already in use. You may need to use a fixed value or digital communications for some external values. To check the current polling configuration, choose **Device Tools** → **Configuration** → **Polled Variables**.

### Procedure

1. Choose **Device Tools** → **Configuration** → **Process Measurement** → **Compressibility**.
2. Set **Compressibility Calculations** as desired, and click **Apply**.

Option	Description
Disabled	The meter will not calculate compressibility. You must enter fixed values for line compressibility and base compressibility.
Enabled	The meter will calculate line compressibility and base compressibility. You must provide gas composition data.

3. If you set **Compressibility Calculations** to Disabled:
  - a) Set **Line Compressibility** to the compressibility of your sample gas at line temperature and line pressure.  
The default value is 0. The range is 0.7 to 1.1.
  - b) Set **Base Compressibility** to the compressibility of your sample gas at base temperature and base pressure.

The default value is 1.0. The range is 0.7 to 1.1.

c) Click **Apply**. No further actions are required.

4. If you set **Compressibility Calculations** to Enabled, complete the configuration as described in the following steps.
5. Select the compressibility measurement method that you want to use or that meets site standards.

#### Important

- Different options are available depending on your primary process variable: specific gravity, molecular weight, or relative density.
- If you choose AGA NX 19 Mod 3 or SGERG 88, you must set up energy content measurement. If you choose any other method, energy content measurement is required only if you want the meter to report calorific value, Wobbe index, or energy flow.
- Each compressibility measurement method has associated process limits. If your process goes outside the valid range, compressibility will be reported as NaN (Not a Number), and all process variables that require a calculated compressibility value will also be reported as NaN.

6. Set **% CO2 Source** to the method you will use to supply % CO2 data, and perform the required setup.

Option	Description	Setup
Polling	The meter polls an external device for % CO2 data.	<ol style="list-style-type: none"> <li>a. Set <b>% CO2 Source</b> to Poll for External Value.</li> <li>b. Set <b>Polling Slot</b> to an available slot.</li> <li>c. Set <b>Polling Control</b> to Poll as Primary or Poll as Secondary.</li> <li>d. Set <b>External Device Tag</b> to the HART tag of the % CO2 measurement device.</li> </ol>
Digital communications	A host writes % CO2 data to the meter at appropriate intervals.	<ol style="list-style-type: none"> <li>a. Set <b>% CO2 Source</b> to Fixed Value or Digital Communications.</li> <li>b. Perform the necessary host programming and communications setup to write % CO2 data to the meter at appropriate intervals.</li> </ol>
Fixed value	The configured fixed value is used.	<ol style="list-style-type: none"> <li>a. Set <b>% CO2 Source</b> to Fixed Value or Digital Communications.</li> <li>b. Set <b>% CO2 (Fixed)</b> to the desired value, in % by volume.</li> </ol>

7. Set **% N2 Source** to the method you will use to supply % N2 data, and perform the required setup.

Option	Description	Setup
Polling	The meter polls an external device for % N2 data.	<ul style="list-style-type: none"> <li>a. Set <b>% N2 Source</b> to Poll for External Value.</li> <li>b. Set <b>Polling Slot</b> to an available slot.</li> <li>c. Set <b>Polling Control</b> to Poll as Primary or Poll as Secondary.</li> <li>d. Set <b>External Device Tag</b> to the HART tag of the % N2 measurement device.</li> </ul>
Digital communications	A host writes % N2 data to the meter at appropriate intervals.	<ul style="list-style-type: none"> <li>a. Set <b>% N2 Source</b> to Fixed Value or Digital Communications.</li> <li>b. Perform the necessary host programming and communications setup to write % N2 data to the meter at appropriate intervals.</li> </ul>
Fixed value	The configured fixed value is used.	<ul style="list-style-type: none"> <li>a. Set <b>% N2 Source</b> to Fixed Value or Digital Communications.</li> <li>b. Set <b>% N2 (Fixed)</b> to the desired value, in % by volume.</li> </ul>

8. If you set **Compressibility Measurement Method** to SGERG 88, set **% H2 Source** to the method you will use to supply % H2 data, and perform the required setup.

Option	Description	Setup
Polling	The meter polls an external device for % H2 data.	<ul style="list-style-type: none"> <li>a. Set <b>% H2 Source</b> to Poll for External Value.</li> <li>b. Set <b>Polling Slot</b> to an available slot.</li> <li>c. Set <b>Polling Control</b> to Poll as Primary or Poll as Secondary.</li> <li>d. Set <b>External Device Tag</b> to the HART tag of the % H2 measurement device.</li> </ul>
Digital communications	A host writes % H2 data to the meter at appropriate intervals.	<ul style="list-style-type: none"> <li>a. Set <b>% H2 Source</b> to Fixed Value or Digital Communications.</li> <li>b. Perform the necessary host programming and communications setup to write % H2 data to the meter at appropriate intervals.</li> </ul>
Fixed value	The configured fixed value is used.	<ul style="list-style-type: none"> <li>a. Set <b>% H2 Source</b> to Fixed Value or Digital Communications.</li> <li>b. Set <b>% H2 (Fixed)</b> to the desired value, in % by volume.</li> </ul>

## 7.4.1 Compressibility Method and process limits

Each method for calculating compressibility has specific limits for line temperature, line pressure, and other process variables. If your process goes outside the valid range, compressibility will be reported as NaN (Not a Number). All process variables that require compressibility will also be reported as NaN.

**Table 7-1: Specific gravity and molecular weight meters: Compressibility Method and valid ranges for process variables**

Compressibility Method	Valid range					
	Temperature	Pressure	Specific gravity	% CO2	% N2	% H2
AGA NX-19	-40 to +115.556 °C	1.01325 to 345.751 BarA	0.55 to 1	0-15%	0-15%	0-15%
AGA NX-19 Mod	-40 to +115.556 °C	0 to 137.9 BarA	0.554 to 0.75	0-15%	0-15%	N/A
AGA NX-19 Mod 3	0 to 30 °C	0 to 80 BarA	0.554 to 0.691	0-2.50%	0-7%	0-4%

**Table 7-2: Relative density meters: Compressibility Method and valid ranges for process variables**

Compressibility Method	Valid range					
	Temperature	Pressure	Relative density	% CO2	% N2	% H2
SGERG-88	-30 to +100 °C	0 to 120 BarA	0.55 to 0.9	0-30% <sup>(1)</sup>	0-50% <sup>(1)</sup>	N/A

(1) The sum of CO2 and N2 must be less than 50%.

## 7.5 Configure base density calculations using ProLink III

ProLink III	Device Tools → Configuration → Process Measurement → Base Density
-------------	---

The base density parameters provide data for the base density calculations. Base density can be reported as a process variable. For specific gravity meters and relative density meters, base density is required for line density measurement.

### Procedure

1. Choose **Device Tools** → **Configuration** → **Process Measurement** → **Base Density**.
2. Set **Density Unit** to the unit to be used for base density, and click **Apply**.

This unit is also used for line density.

3. Set **Base Pressure** to the pressure value to which density measurements will be corrected (the reference pressure).

The default is 1 bar absolute. There is no upper limit. You must be using absolute pressure.

This value is also used in line density measurement. Be sure that the value is appropriate for both process variables.



4. Set **Base Temperature** to the temperature value to which density measurements will be corrected (the reference temperature).

The default is 20 °C. The range is -50 °C to +200 °C.

This value is also used in line density measurement. Be sure that the value is appropriate for both process variables.

5. (Relative density meters only) Set **Density of Air** to the value to be used in your application.

Enter the value in the configured measurement unit. The default is 0.000122305 g/cm<sup>3</sup>. The range is 0.0001 g/cm<sup>3</sup> to 0.00015 g/cm<sup>3</sup>.

## 7.5.1 Options for Density Measurement Unit

The transmitter provides a standard set of measurement units for **Density Measurement Unit**. Different communications tools may use different labels.

Unit description	Label		
	Display	ProLink III	Field communicator
Grams per cubic centimeter	G/CM3	g/cm3	g/Cucm
Grams per liter	G/L	g/l	g/L
Grams per milliliter	G/mL	g/ml	g/mL
Kilograms per liter	KG/L	kg/l	kg/L
Kilograms per cubic meter	KG/M3	kg/m3	kg/Cum
Pounds per U.S. gallon	LB/GAL	lbs/Usgal	lb/gal
Pounds per cubic foot	LB/CUF	lbs/ft3	lb/Cuft
Pounds per cubic inch	LB/CUI	lbs/in3	lb/Cuin
Short ton per cubic yard	ST/CUY	sT/yd3	STon/Cuyd
Degrees API	D API	degAPI	degAPI
Special unit	SPECL	special	Spcl

## 7.5.2 Define a special measurement unit for density

ProLink III	Device Tools → Configuration → Process Measurement → Line Density → Special Units
Field communicator	Configure → Manual Setup → Measurements → Optional Setup → Special Units

A special measurement unit is a user-defined unit of measure that allows you to report process data in a unit that is not available in the transmitter. A special measurement unit is calculated from an existing measurement unit using a conversion factor.

### Procedure

1. Specify **Density Special Unit Base**.

**Density Special Unit Base** is the existing density unit that the special unit will be based on.

2. Calculate **Density Special Unit Conversion Factor** as follows:

- a)  $x \text{ base units} = y \text{ special units}$
- b) **Density Special Unit Conversion Factor** =  $x \div y$

3. Enter **Density Special Unit Conversion Factor**.

The original density value is divided by this conversion factor.

4. Set **User-Defined Label** to the name you want to use for the density unit.

The special measurement unit is stored in the transmitter. You can configure the transmitter to use the special measurement unit at any time.

### Defining a special measurement unit for density

You want to measure density in ounces per cubic inch.

1. Set **Density Special Unit Base** to g/cm<sup>3</sup>.
2. Calculate **Density Special Unit Conversion Factor**:
  - a.  $1 \text{ g/cm}^3 = 0.578 \text{ oz/in}^3$
  - b.  $1 \div 0.578 = 1.73$
3. Set **Density Special Unit Conversion Factor** to 1.73.
4. Set **User-Defined Label** to oz/in<sup>3</sup>.

## 7.6 Configure line density calculations using ProLink III

ProLink III	Device Tools → Configuration → Process Measurement → Line Density
-------------	---

The line density parameters provide data for line density measurement. Line density can be reported as a process variable. Line density is required to measure calorific value and energy flow.

### Procedure

1. Choose **Device Tools** → **Configuration** → **Process Measurement** → **Line Density**.
2. Set **Density Unit** to the unit to be used for line density, and click **Apply**.
 

This unit is also used for base density.
3. Verify the value of **Line Pressure**.
4. Verify the value of **Sample Temperature**.
5. Set **Base Pressure** to the pressure value to which density measurements will be corrected (the reference pressure).
 

The default is 1 bar absolute. There is no upper limit. You must be using absolute pressure.

This value is also used in base density measurement. Be sure that the value is appropriate for both process variables.
6. Set **Base Temperature** to the temperature value to which density measurements will be corrected (the reference temperature).

The default is 20 °C. The range is –50 °C to +200 °C.

This value is also used in base density measurement. Be sure that the value is appropriate for both process variables.

7. (Relative density meters only) Set **Density of Air** to the value to be used in your application.

The default is 0.000122305 g/cm<sup>3</sup>. The range is 0.0001 g/cm<sup>3</sup> to 0.00015 g/cm<sup>3</sup>.

## 7.7 Configure energy content measurement using ProLink III

ProLink III	Device Tools → Configuration → Process Measurement → Calorific Value/BTU/Wobbe Index/Energy Flow
-------------	--

The energy content parameters are used to measure and calculate calorific value, Wobbe index, and energy flow.

### Prerequisites

You must be able to supply gas composition data to the meter, for the following constituents:

- Carbon monoxide (CO)
- Carbon dioxide (CO<sub>2</sub>)
- Nitrogen (N<sub>2</sub>)
- Hydrogen (H<sub>2</sub>)

Gas composition must be measured in % by volume.

If you plan to measure energy flow, you must be able to supply flow data to the meter. You have the following options:

- If you are using an external volume flow device, Volume Flow (External) and Mass Flow (Calculated) are available.
- If you are using an external mass flow device, Mass Flow (External) and Volume Flow (Calculated) are available.

### Tip

In either case, you can measure energy flow in either mass units or volume units. The meter automatically selects the appropriate process variable.

If you plan to poll an external device for any of these, ensure that the meter has the required polling slots available. The meter provides four polling slots, and they may be already in use. You may need to use a fixed value or digital communications for some external values. To check the current polling configuration, choose **Device Tools** → **Configuration** → **Polled Variables**. If you are already polling for one of these, you can use the existing polled data.

### Procedure

1. Choose **Device Tools** → **Configuration** → **Process Measurement** → **Calorific Value/BTU/Wobbe Index/Energy Flow**.
2. Set **Calorific Value Units** to the unit to be used to measure energy content.

3. Set **% CO Source** to the method you will use to supply % CO data, and perform the required setup.

Option	Description	Setup
Polling	The meter polls an external device for % CO data.	<ol style="list-style-type: none"> <li>Set <b>% CO Source</b> to Poll for External Value.</li> <li>Set <b>Polling Slot</b> to an available slot.</li> <li>Set <b>Polling Control</b> to Poll as Primary or Poll as Secondary.</li> <li>Set <b>External Device Tag</b> to the HART tag of the % CO measurement device.</li> </ol>
Digital communications	A host writes % CO data to the meter at appropriate intervals.	<ol style="list-style-type: none"> <li>Set <b>% CO Source</b> to Fixed Value or Digital Communications.</li> <li>Perform the necessary host programming and communications setup to write % CO data to the meter at appropriate intervals.</li> </ol>
Fixed value	The configured fixed value is used.	<ol style="list-style-type: none"> <li>Set <b>% CO Source</b> to Fixed Value or Digital Communications.</li> <li>Set <b>% CO (Fixed)</b> to the desired value, in % by volume.</li> </ol>

4. Set **% CO<sub>2</sub> Source** to the method you will use to supply % CO<sub>2</sub> data, and perform the required setup.

Option	Description	Setup
Polling	The meter polls an external device for % CO <sub>2</sub> data.	<ol style="list-style-type: none"> <li>Set <b>% CO<sub>2</sub> Source</b> to Poll for External Value.</li> <li>Set <b>Polling Slot</b> to an available slot.</li> <li>Set <b>Polling Control</b> to Poll as Primary or Poll as Secondary.</li> <li>Set <b>External Device Tag</b> to the HART tag of the % CO<sub>2</sub> measurement device.</li> </ol>
Digital communications	A host writes % CO <sub>2</sub> data to the meter at appropriate intervals.	<ol style="list-style-type: none"> <li>Set <b>% CO<sub>2</sub> Source</b> to Fixed Value or Digital Communications.</li> <li>Perform the necessary host programming and communications setup to write % CO<sub>2</sub> data to the meter at appropriate intervals.</li> </ol>
Fixed value	The configured fixed value is used.	<ol style="list-style-type: none"> <li>Set <b>% CO<sub>2</sub> Source</b> to Fixed Value or Digital Communications.</li> <li>Set <b>% CO<sub>2</sub> (Fixed)</b> to the desired value, in % by volume.</li> </ol>

5. Set **% N<sub>2</sub> Source** to the method you will use to supply % N<sub>2</sub> data, and perform the required setup.

Option	Description	Setup
Polling	The meter polls an external device for % N2 data.	<ul style="list-style-type: none"> <li>a. Set <b>% N2 Source</b> to Poll for External Value.</li> <li>b. Set <b>Polling Slot</b> to an available slot.</li> <li>c. Set <b>Polling Control</b> to Poll as Primary or Poll as Secondary.</li> <li>d. Set <b>External Device Tag</b> to the HART tag of the % N2 measurement device.</li> </ul>
Digital communications	A host writes % N2 data to the meter at appropriate intervals.	<ul style="list-style-type: none"> <li>a. Set <b>% N2 Source</b> to Fixed Value or Digital Communications.</li> <li>b. Perform the necessary host programming and communications setup to write % N2 data to the meter at appropriate intervals.</li> </ul>
Fixed value	The configured fixed value is used.	<ul style="list-style-type: none"> <li>a. Set <b>% N2 Source</b> to Fixed Value or Digital Communications.</li> <li>b. Set <b>% N2 (Fixed)</b> to the desired value, in % by volume.</li> </ul>

6. Set **% H2 Source** to the method you will use to supply % H2 data, and perform the required setup.

Option	Description	Setup
Polling	The meter polls an external device for % H2 data.	<ul style="list-style-type: none"> <li>a. Set <b>% H2 Source</b> to Poll for External Value.</li> <li>b. Set <b>Polling Slot</b> to an available slot.</li> <li>a. Set <b>Polling Control</b> to Poll as Primary or Poll as Secondary.</li> <li>b. Set <b>External Device Tag</b> to the HART tag of the % H2 measurement device.</li> </ul>
Digital communications	A host writes % H2 data to the meter at appropriate intervals.	<ul style="list-style-type: none"> <li>a. Set <b>% H2 Source</b> to Fixed Value or Digital Communications.</li> <li>b. Perform the necessary host programming and communications setup to write % H2 data to the meter at appropriate intervals.</li> </ul>
Fixed value	The configured fixed value is used.	<ul style="list-style-type: none"> <li>a. Set <b>% H2 Source</b> to Fixed Value or Digital Communications.</li> <li>b. Set <b>% H2 (Fixed)</b> to the desired value, in % by volume.</li> </ul>

7. Optional: To configure Volume Flow (External) and Mass Flow (Calculated):

- a) Set **Energy Flow Units** to the unit to be used to measure energy flow.
- b) Set **Mass Flow (Calculated)** to Enabled.
- c) Set **Standard Volume Flow Rate Units** to the units used by the external volume measurement device
- d) set **Volume Flow Source** to the method you will use to supply volume flow data, and perform the required setup.

Option	Description	Setup
Polling	The meter polls an external device for volume flow data and calculates the equivalent mass flow.	<ol style="list-style-type: none"> <li>1. Set <b>Volume Flow Source</b> to Poll for External Value.</li> <li>2. Set <b>Polling Slot</b> to an available slot.</li> <li>3. Set <b>Polling Control</b> to Poll as Primary or Poll as Secondary.</li> <li>4. Set <b>External Device Tag</b> to the HART tag of the volume flow measurement device.</li> </ol>
Digital communications	A host writes volume flow data to the meter at appropriate intervals, and the meter calculates the equivalent mass flow.	<ol style="list-style-type: none"> <li>1. Set <b>Volume Flow Source</b> to Fixed Value or Digital Communications.</li> <li>2. Perform the necessary host programming and communications setup to write volume flow data to the meter at appropriate intervals.</li> </ol>
Fixed value	The configured fixed value is used for volume flow, and the meter calculates the equivalent mass flow.	<ol style="list-style-type: none"> <li>1. Set <b>Volume Flow Source</b> to Fixed Value or Digital Communications.</li> <li>2. Set <b>Volume Flow (Fixed)</b> to the desired value.</li> </ol>

8. Optional: To configure Mass Flow (External) and Volume Flow (Calculated):
- a) Set **Energy Flow Units** to the unit to be used to measure energy flow.
  - b) Set **Standard Volume Flow (Calculated)** to Enabled.
  - c) Set **Mass Flow Rate Units** to the units used by the external mass measurement device.
  - d) Set **Mass Flow Source** to the method you will use to supply mass flow data, and perform the required setup.

Option	Description	Setup
Polling	The meter polls an external device for mass flow data and calculates the equivalent volume flow.	<ol style="list-style-type: none"> <li>1. Set <b>Mass Flow Source</b> to Poll for External Value.</li> <li>2. Set <b>Polling Slot</b> to an available slot.</li> <li>3. Set <b>Polling Control</b> to Poll as Primary or Poll as Secondary.</li> <li>4. Set <b>External Device Tag</b> to the HART tag of the mass flow measurement device.</li> </ol>
Digital communications	A host writes mass flow data to the meter at appropriate intervals, and the meter calculates the equivalent volume flow.	<ol style="list-style-type: none"> <li>1. Set <b>Mass Flow Source</b> to Fixed Value or Digital Communications.</li> <li>2. Perform the necessary host programming and communications setup to write mass flow data to the meter at appropriate intervals.</li> </ol>
Fixed value	The configured fixed value is used for mass flow, and the meter calculates the equivalent volume flow.	<ol style="list-style-type: none"> <li>1. Set <b>Mass Flow Source</b> to Fixed Value or Digital Communications.</li> <li>2. Set <b>Mass Flow (Fixed)</b> to the desired value.</li> </ol>

## 7.8 Set up concentration measurement using ProLink III

This section guides you through the tasks required to set up, configure, and implement concentration measurement.

### 7.8.1 Enable the concentration measurement application using ProLink III

The concentration measurement application must be enabled before you can perform any setup. If the concentration measurement application was enabled at the factory, you do not need to enable it now.

#### Procedure

1. Choose **Device Tools** → **Configuration** → **Transmitter Options**.
2. Set **Concentration Measurement** to Enabled and click **Apply**.

### 7.8.2 Configure a concentration measurement matrix using ProLink III

A concentration measurement matrix defines the relationship between density and concentration for your process gas. You can configure up to six matrices.

#### Prerequisites

You must know the primary and secondary constituents of your process gas, and the density of each constituent in pure form.

#### Procedure

1. Choose **Device Tools** → **Configuration** → **Process Measurement** → **Concentration Measurement**.
2. To use a gas variable, set **Gas Purity Variable** to Specific Gravity, Molecular Weight, or Relative Density.

Meter	Available option
Specific gravity	Specific Gravity or Molecular Weight
Molecular weight	Specific Gravity or Molecular Weight
Relative density	Relative Density

3. Set **Matrix Being Configured** to the matrix you want to configure and click **Change Matrix**.
4. Set **Concentration Units Label** to the label to use for the measurement unit.

This selection does not affect measurement. It only selects a label.

5. If you set **Concentration Units** to Special, enter a string for the custom label.
6. Enter a name for the matrix.
7. Enter the density of the primary constituent of your process gas, in its pure form.
8. Enter the density of the secondary constituent of your process gas, in its pure form.
9. Click **Apply**.

### 7.8.3 Select the active concentration matrix using ProLink III

You must select the concentration matrix to be used for measurement. Although the transmitter can store up to six concentration matrices, only one matrix can be used for measurement at any one time.

#### Procedure

1. Choose **Device Tools** → **Configuration** → **Process Measurement** → **Concentration Measurement**.
2. Set **Active Matrix** to the matrix you want to use and click **Change Matrix**.



## 8 Configure process measurement using a field communicator

### 8.1 Configure density measurement using a field communicator

The density measurement parameters control how density is measured and reported.

#### Related information

[Configure Density Measurement Unit using a field communicator](#)

[Configure Density Damping using a field communicator](#)

#### 8.1.1 Configure Density Measurement Unit using a field communicator

Field communicator	Configure → Manual Setup → Measurements → Density → Density Unit
--------------------	--

**Density Measurement Unit** controls the measurement units that will be used in gas measurement, calculations, and reporting.

#### Procedure

Set **Density Measurement Unit** to the option you want to use.

The default setting for **Density Measurement Unit** is g/cm<sup>3</sup> (grams per cubic centimeter).

#### Options for Density Measurement Unit

The transmitter provides a standard set of measurement units for **Density Measurement Unit**. Different communications tools may use different labels.

Unit description	Label		
	Display	ProLink III	Field communicator
Grams per cubic centimeter	G/CM3	g/cm3	g/Cucm
Grams per liter	G/L	g/l	g/L
Grams per milliliter	G/mL	g/ml	g/mL
Kilograms per liter	KG/L	kg/l	kg/L
Kilograms per cubic meter	KG/M3	kg/m3	kg/Cum
Pounds per U.S. gallon	LB/GAL	lbs/Usgal	lb/gal
Pounds per cubic foot	LB/CUF	lbs/ft3	lb/Cuft
Pounds per cubic inch	LB/CI	lbs/in3	lb/Cuin
Short ton per cubic yard	ST/CUY	sT/yd3	STon/Cuyd

Unit description	Label		
	Display	ProLink III	Field communicator
Degrees API	D API	degAPI	degAPI
Special unit	SPECL	special	Spcl

## Define a special measurement unit for density

ProLink III	Device Tools → Configuration → Process Measurement → Line Density → Special Units
Field communicator	Configure → Manual Setup → Measurements → Optional Setup → Special Units

A special measurement unit is a user-defined unit of measure that allows you to report process data in a unit that is not available in the transmitter. A special measurement unit is calculated from an existing measurement unit using a conversion factor.

### Procedure

1. Specify **Density Special Unit Base**.

**Density Special Unit Base** is the existing density unit that the special unit will be based on.

2. Calculate **Density Special Unit Conversion Factor** as follows:

a)  $x \text{ base units} = y \text{ special units}$

b) **Density Special Unit Conversion Factor** =  $x \div y$

3. Enter **Density Special Unit Conversion Factor**.

The original density value is divided by this conversion factor.

4. Set **User-Defined Label** to the name you want to use for the density unit.

The special measurement unit is stored in the transmitter. You can configure the transmitter to use the special measurement unit at any time.

### Defining a special measurement unit for density

You want to measure density in ounces per cubic inch.

1. Set **Density Special Unit Base** to g/cm<sup>3</sup>.
2. Calculate **Density Special Unit Conversion Factor**:
  - a.  $1 \text{ g/cm}^3 = 0.578 \text{ oz/in}^3$
  - b.  $1 \div 0.578 = 1.73$
3. Set **Density Special Unit Conversion Factor** to 1.73.
4. Set **User-Defined Label** to oz/in<sup>3</sup>.

## 8.1.2 Configure Density Damping using a field communicator

Field communicator	Configure → Manual Setup → Measurements → Density → Density Damping
--------------------	---

**Damping** controls the amount of damping that will be applied to the primary process variable: specific gravity, molecular weight, or relative density.

Damping is used to smooth out small, rapid fluctuations in process measurement. **Damping Value** specifies the time period (in seconds) over which the transmitter will spread changes in the process variable. At the end of the interval, the internal value will reflect 63% of the change in the actual measured value.

---

**Tip**

Damping affects all process variables that are calculated from the primary process variable: specific gravity, molecular weight, or relative density.

---

**Procedure**

Set **Damping** to the value you want to use.

The default value is 1.6 seconds. The range is 0 to 440 seconds.

## Interaction between Damping and Added Damping

When the mA Output is configured to report the primary process variable (specific gravity, molecular weight, or relative density), both **Damping** and **Added Damping** are applied to the reported value.

**Damping** controls the rate of change in the value of the process variable in transmitter memory. **Added Damping** controls the rate of change reported via the mA Output.

If **mA Output Process Variable** is set to Specific Gravity, Molecular Weight, or Relative Density, and both **Damping** and **Added Damping** are set to non-zero values, the primary process variable damping is applied first, and the added damping calculation is applied to the result of the first calculation. This value is reported over the mA Output.

## 8.2 Configure temperature measurement using a field communicator

The temperature measurement parameters control how temperature is measured and reported.

**Related information**

[Configure Temperature Measurement Unit using a field communicator](#)

[Configure Temperature Damping using a field communicator](#)

### 8.2.1 Configure Temperature Measurement Unit using a field communicator

Field communicator	Configure → Manual Setup → Measurements → Temperature → Temperature Unit
--------------------	--

**Temperature Measurement Unit** specifies the unit that will be used for temperature measurement.

**Procedure**

Set **Temperature Measurement Unit** to the option you want to use.

The default setting is Degrees Celsius.

**Important**

If you plan to use an external temperature device, you must set **Temperature Measurement Unit** to the unit used by the external device.

**Options for Temperature Measurement Unit**

The transmitter provides a standard set of units for **Temperature Measurement Unit**. Different communications tools may use different labels for the units.

Unit description	Label		
	Display	ProLink III	Field communicator
Degrees Celsius	°C	°C	degC
Degrees Fahrenheit	°F	°F	degF
Degrees Rankine	°R	°R	degR
Kelvin	°K	°K	Kelvin

**8.2.2 Configure Temperature Damping using a field communicator**

Field communicator	Configure → Manual Setup → Measurements → Temperature → Temp Damping
--------------------	--

**Temperature Damping** controls the amount of damping that will be applied to the sample temperature value, when the on-board temperature data is used (RTD).

Damping is used to smooth out small, rapid fluctuations in process measurement. **Damping Value** specifies the time period (in seconds) over which the transmitter will spread changes in the process variable. At the end of the interval, the internal value will reflect 63% of the change in the actual measured value.

**Tip**

**Temperature Damping** affects all process variables, compensations, and corrections that use temperature data from the sensor.

**Procedure**

Enter the value you want to use for **Temperature Damping**.

The default value is 4.8 seconds. The range is 0 to 38.4 seconds.

**Tip**

- A high damping value makes the process variable appear smoother because the reported value changes slowly.
- A low damping value makes the process variable appear more erratic because the reported value changes more quickly.
- Whenever the damping value is non-zero, the reported measurement will lag the actual measurement because the reported value is being averaged over time.
- In general, lower damping values are preferable because there is less chance of data loss, and less lag time between the actual measurement and the reported value.

The value you enter is automatically rounded to the nearest valid value. Valid values for **Temperature Damping** are 0, 0.6, 1.2, 2.4, 4.8, ... 38.4.

## 8.3 Configure gas measurement using a field communicator

This section guides you through the tasks required to set up and configure gas measurement.

### Related information

[Configure fundamental gas measurement parameters using a field communicator](#)

[Configure gas compressibility measurement using a field communicator](#)

[Configure energy content measurement using a field communicator](#)

### 8.3.1 Configure fundamental gas measurement parameters using a field communicator

The fundamental gas measurement parameters are required for all gas process variables.

#### Prerequisites

You must be able to supply pressure data to the meter.

You must be using absolute pressure.

If you plan to poll an external device for pressure or temperature, ensure that the meter has the required polling slots available. The meter provides four polling slots, and they may be already in use. You may need to use a fixed value for some external values. To check the current polling configuration, choose **Configure** → **Manual Setup** → **Inputs/Outputs** → **External Device Polling**. If you are already polling for temperature or pressure, you can use the existing polled data.

---

#### Important

Temperature data is used in several measurements and calculations, for example: gas measurement, temperature compensation, and base density. For each of these, you can configure the temperature source. The RTD temperature data is stored separately in device memory. However, if you choose anything other than RTD, be aware that the fixed value and the polled value are stored in the same location in device memory. As a result, polled data will overwrite a fixed value.

Before you decide how to supply temperature data, consider the other ways that sample temperature data will be used and plan accordingly.

---

#### Procedure

1. Choose **Configure** → **Manual Setup** → **Measurements** → **Optional Setup** → **Gas Measurement** → **Calculation Constants**.
2. Set **Base Density** to the density of your process gas at reference temperature and reference pressure.
3. Set **Base Temperature** to the temperature value to which gas measurements will be corrected (the reference temperature).
4. Set **Molecular Weight of Air** to the value to be used in your application.  
The default value is 28.96469 g/mol. This value is appropriate for most applications.
5. Optional: Set **Base Compressibility** to the compressibility of your process gas at reference temperature and reference pressure.

Set **Base Compressibility** only if you do not plan to set up compressibility measurement.

6. Choose the method to be used to supply temperature data, and perform the required setup.

Method	Description	Setup
Internal temperature data	Temperature data from the on-board temperature sensor (RTD) will be used.	<ol style="list-style-type: none"> <li>Choose <b>Configure</b> → <b>Manual Setup</b> → <b>Measurements</b> → <b>Optional Setup</b> → <b>Gas Measurement</b> → <b>Temperature</b>.</li> <li>Set <b>External Temperature for Gas</b> to Disable.</li> </ol>
Polling	The meter polls an external device for temperature data.	<ol style="list-style-type: none"> <li>Choose <b>Configure</b> → <b>Manual Setup</b> → <b>Measurements</b> → <b>Optional Setup</b> → <b>Gas Measurement</b> → <b>Temperature</b>.</li> <li>Set <b>External Temperature for Gas</b> to Enable.</li> <li>Choose <b>Configure</b> → <b>Manual Setup</b> → <b>Inputs/Outputs</b> → <b>External Device Polling</b>.</li> <li>Choose an unused polling slot.</li> <li>Set <b>Poll Control</b> to Poll as Primary or Poll as Secondary.</li> <li>Set <b>External Device Tag</b> to the HART tag of the external temperature device.</li> <li>Set <b>Polled Variable</b> to Temperature.</li> </ol>

#### Tip

A fixed temperature value is not recommended. Gas measurement is very sensitive to temperature, and a fixed temperature value may produce inaccurate process data.

7. Set up the pressure input.

- Choose **Configure** → **Manual Setup** → **Inputs/Outputs** → **External Device Polling**.
- Choose an unused polling slot.
- Set **Poll Control** to Poll as Primary or Poll as Secondary.
- Set **External Device Tag** to the HART tag of the external pressure device.
- Set **Polled Variable** to Pressure.
- Choose **Configure** → **Manual Setup** → **Measurements** → **Pressure**.
- Set **Pressure Unit** to the unit used by the external pressure device.
- Optional: Choose **Configure** → **Manual Setup** → **Measurements** → **Optional Setup** → **Gas Measurement** → **Pressure**.
- Set **Pressure Offset** to the value required to adjust the pressure data for this meter.

#### Tip

A fixed pressure value is not recommended. Gas measurement is very sensitive to pressure, and a fixed pressure value may produce inaccurate process data.

## 8.3.2 Configure gas compressibility measurement using a field communicator

Gas compressibility measurement is required for the following process variables: line density, calorific value, Wobbe index, and energy flow. Gas compressibility measurement can also be used to calculate compressibility as an independent process variable.

### Prerequisites

You must know whether you will measure line compressibility and base compressibility or you will use fixed values.

If you will use fixed values, you must know the line compressibility and base compressibility values for your application.

If you will measure compressibility, you must be able to supply gas composition data to the meter, for the following constituents:

- Carbon dioxide (CO<sub>2</sub>)
- Nitrogen (N<sub>2</sub>)
- Hydrogen (H<sub>2</sub>) (required only if you plan to measure compressibility according to SGERG 88)

Gas composition must be measured in % by volume.

If you plan to poll an external device for % CO<sub>2</sub>, % N<sub>2</sub>, or % H<sub>2</sub>, ensure that the meter has the required polling slots available. The meter provides four polling slots, and they may be already in use. You may need to use a fixed value or digital communications for some external values. To check the current polling configuration, choose **Configure** → **Manual Setup** → **Inputs/Outputs** → **External Device Polling**.

### Procedure

1. Configure the meter to use fixed values or to measure compressibility.
  - a) Choose **Service Tools** → **Maintenance** → **Modbus Data** → **Write Modbus Data**.
  - b) To use fixed values, write 0 to Coil 442.
  - c) To measure compressibility, write 1 to Coil 442.
2. If you are using fixed values:
  - a) Write the line compressibility value to Registers 4183-4184, in 32-bit IEEE floating-point format. The default value is 0. The range is unrestricted.
  - b) Write the base compressibility value to Registers 4141-4142, in 32-bit IEEE floating-point format. The default value is 1.0. The range is 0.7 to 1.1.

No further actions are required.

3. If you are measuring compressibility, complete the configuration as described in the following steps.
4. Choose **Configure** → **Manual Setup** → **Measurements** → **Optional Setup** → **Gas Measurement** → **Setup Compressibility**.

- Choose **Compressibility Method** and select the compressibility measurement method that you want to use or that meets site standards.

---

#### Important

- Each compressibility measurement method has associated process limits. If your process goes outside the valid range, compressibility will be reported as NaN (Not a Number), and all process variables that require a calculated compressibility value will also be reported as NaN.
  - If you choose AGA NX 19 Mod 3 or SGERG 88, you must set up energy content measurement. If you choose any other method, energy content measurement is required only if you want the meter to report calorific value, Wobbe index, or energy flow.
- 
- If you want to use fixed values for **Percent CO<sub>2</sub>**, **Percent N<sub>2</sub>**, and/or **Percent H<sub>2</sub>**, Choose **Configure** → **Manual Setup** → **Measurements** → **Optional Setup** → **Gas Measurement** → **Setup Compressibility** → **Gas Composition**, and enter the fixed values, in % by volume.
  - If you want to poll for **Percent CO<sub>2</sub>**, **Percent N<sub>2</sub>**, and/or **Percent H<sub>2</sub>**:
    - Choose **Configure** → **Manual Setup** → **Inputs/Outputs** → **External Device Polling**.
    - Choose an unused polling slot.
    - Set **Poll Control** to Poll as Primary or Poll as Secondary.
    - Set **External Device Tag** to the HART tag of the external measurement device.
    - Set **Polled Variable** to the appropriate variable.

#### Related information

[Compressibility Method and process limits](#)

### Compressibility Method and process limits

Each method for calculating compressibility has specific limits for line temperature, line pressure, and other process variables. If your process goes outside the valid range, compressibility will be reported as NaN (Not a Number). All process variables that require compressibility will also be reported as NaN.

**Table 8-1: Specific gravity and molecular weight meters: Compressibility Method and valid ranges for process variables**

Compressibility Method	Valid range					
	Temperature	Pressure	Specific gravity	% CO <sub>2</sub>	% N <sub>2</sub>	% H <sub>2</sub>
AGA NX-19	-40 to +115.556 °C	1.01325 to 345.751 BarA	0.55 to 1	0-15%	0-15%	0-15%
AGA NX-19 Mod	-40 to +115.556 °C	0 to 137.9 BarA	0.554 to 0.75	0-15%	0-15%	N/A
AGA NX-19 Mod 3	0 to 30 °C	0 to 80 BarA	0.554 to 0.691	0-2.50%	0-7%	0-4%



**Table 8-2: Relative density meters: Compressibility Method and valid ranges for process variables**

Compressibility Method	Valid range					
	Temperature	Pressure	Relative density	% CO2	% N2	% H2
SGERG-88	-30 to +100 °C	0 to 120 BarA	0.55 to 0.9	0–30% <sup>(1)</sup>	0–50% <sup>(1)</sup>	N/A

(1) The sum of CO2 and N2 must be less than 50%.

### 8.3.3 Configure energy content measurement using a field communicator

The energy content parameters are used to measure and calculate calorific value, Wobbe index, and energy flow.

#### Prerequisites

You must be able to supply gas composition data to the meter, for the following constituents:

- Carbon monoxide (CO)
- Carbon dioxide (CO2)
- Nitrogen (N2)
- Hydrogen (H2)

Gas composition must be measured in % by volume.

If you plan to measure energy flow, you must be able to supply flow data to the meter. You have the following options:

- If you are using an external volume flow device, Volume Flow (External) and Mass Flow (Calculated) are available.
- If you are using an external mass flow device, Mass Flow (External) and Volume Flow (Calculated) are available.

---

#### Tip

In either case, you can measure energy flow in either mass units or volume units. The meter automatically selects the appropriate process variable.

---

If you plan to poll an external device for any of these, ensure that the meter has the required polling slots available. The meter provides four polling slots, and they may be already in use. You may need to use a fixed value or digital communications for some external values. To check the current polling configuration, choose **Configure** → **Manual Setup** → **Inputs/Outputs** → **External Device Polling**. If you are already polling for one of these, you can use the existing polled data.

#### Procedure

1. Set the measurement units.
  - a) Choose **Configure** → **Manual Setup** → **Measurements** → **Energy**.
  - b) Set **Calorific Value Unit** to the unit to be used to measure calorific value.

- c) Optional: Set **Energy Flow Unit** to the unit to be used to measure energy flow.
2. If you want to use fixed values for **Percent CO**, **Percent CO<sub>2</sub>**, **Percent N<sub>2</sub>**, and/or **Percent H<sub>2</sub>**:
    - a) Choose **Configure** → **Manual Setup** → **Measurements** → **Optional Setup** → **Energy Content Measurement** → **Gas Composition**.
    - b) Enter the fixed values, in % by volume.
  3. If you want to poll for **Percent CO**, **Percent CO<sub>2</sub>**, **Percent N<sub>2</sub>**, and/or **Percent H<sub>2</sub>**:
    - a) Choose **Configure** → **Manual Setup** → **Inputs/Outputs** → **External Device Polling** and click **External Device Polling**.
    - b) Choose an unused polling slot.
    - c) Set **Poll Control** to Poll as Primary or Poll as Secondary.
    - d) Set **External Device Tag** to the HART tag of the external measurement device.
    - e) Set **Polled Variable** to the appropriate variable.
  4. Optional: To configure Volume Flow (External) and Mass Flow (Calculated):
    - a) Choose **Configure** → **Manual Setup** → **Inputs/Outputs** → **External Device Polling**.
    - b) Choose an unused polling slot.
    - c) Set **Poll Control** to Poll as Primary or Poll as Secondary.
    - d) Set **External Device Tag** to the HART tag of the external measurement device.
    - e) Set **Polled Variable** to Volume from Mag/Vortex Meter.
    - f) Choose **Configure** → **Manual Setup** → **Measurements** → **Optional Setup** → **External Inputs** → **Configure External Inputs** → **Volume**.
    - g) Set **Volume Flow Source** to Enable.
    - h) Choose **Configure** → **Manual Setup** → **Measurements** → **Volume**.
    - i) Set **Volume Flow Rate Unit** to the unit used by the external device.
    - j) Choose **Configure** → **Manual Setup** → **Measurements** → **Mass**.
    - k) Set **Mass Flow Rate Unit** to the unit to be used for Mass Flow (Calculated).
  5. Optional: To configure Mass Flow (External) and Volume Flow (Calculated):
    - a) Choose **Configure** → **Manual Setup** → **Inputs/Outputs** → **External Device Polling**.
    - b) Choose an unused polling slot.
    - c) Set **Poll Control** to Poll as Primary or Poll as Secondary.
    - d) Set **External Device Tag** to the HART tag of the external measurement device.
    - e) Set **Polled Variable** to Mass Flow from Coriolis Meter.
    - f) Choose **Configure** → **Manual Setup** → **Measurements** → **Optional Setup** → **External Inputs** → **Configure External Inputs** → **Mass**.

- g) Set **Mass Flow Source** to Enable.
- h) Choose **Configure** → **Manual Setup** → **Measurements** → **Mass**.
- i) Set **Mass Flow Rate Unit** to the unit used by the external device.
- j) Choose **Configure** → **Manual Setup** → **Measurements** → **Gas Standard Volume**.
- k) Set **GSV Flow Unit** to the unit to be used for Volume Flow (Calculated).

## 8.4 Set up concentration measurement using a field communicator

This section guides you through the tasks required to set up, configure, and implement concentration measurement.

### 8.4.1 Enable the concentration measurement application using a field communicator

The concentration measurement application must be enabled before you can perform any setup. If the concentration measurement application was enabled at the factory, you do not need to enable it now.

#### Procedure

1. Choose **Overview** → **Device Information** → **Applications** → **Enable/Disable Applications**.
2. Enable the concentration measurement application.

### 8.4.2 Configure a concentration measurement matrix using a field communicator

A concentration measurement matrix defines the relationship between density and concentration for your process gas. You can configure up to six matrices.

#### Prerequisites

You must know the primary and secondary constituents of your process gas, and the density of each constituent in pure form.

#### Procedure

1. Choose **Configure** → **Manual Setup** → **Measurements** → **Conc Measure (CM)** → **Configure Matrix**.
2. Set **Matrix Being Configured** to the matrix you want to configure.
3. Enter a name for the matrix.
4. Set **Concentration Units** to the label to be used for the measurement unit.  
This selection does not affect measurement. It only selects a label.
5. If you set **Concentration Units** to Special, enter a string for the custom label.
6. Choose **Enter Matrix Data**.
7. Enter the density of the primary constituent of your process gas, in its pure form.

8. Enter the density of the secondary constituent of your process gas, in its pure form.

### 8.4.3 Select the active concentration matrix using a field communicator

You must select the concentration matrix to be used for measurement. Although the transmitter can store up to six concentration matrices, only one matrix can be used for measurement at any one time.

#### Procedure

1. Choose **Configure** → **Manual Setup** → **Measurements** → **Optional Setup** → **Concentration Measurement** → **CM Configuration**.
2. Choose **Configure** → **Manual Setup** → **Measurements** → **Optional Setup** → **Conc Measurement** → **CM Configuration**.
3. Set **Active Matrix** to the matrix you want to use.

## 9 Configure device options and preferences

### 9.1 Configure the transmitter display

You can control the process variables shown on the display and a variety of display behaviors.

#### 9.1.1 Configure the language used for the display

ProLink III	Device Tools → Configuration → Transmitter Display → General
Field communicator	Configure → Manual Setup → Display → Language

**Display Language** controls the language used for process data and menus on the display.

#### Procedure

Select the language you want to use.

The languages available depend on your transmitter model and version.

#### 9.1.2 Configure the process variables and diagnostic variables shown on the display

ProLink III	Device Tools → Configuration → Transmitter Display → Display Variables
Field communicator	Configure → Manual Setup → Display → Display Variables

You can control the process variables and diagnostic variables shown on the display, and the order in which they appear. The display can scroll through up to 15 variables in any order you choose. In addition, you can repeat variables or leave slots unassigned.

#### Restriction

You cannot set **Display Variable 1** to None or to a diagnostic variable. **Display Variable 1** must be set to a process variable.

#### Procedure

For each display variable you want to change, assign the process variable you want to use.

#### 9.1.3 Configure the number of decimal places (precision) shown on the display

ProLink III	Device Tools → Configuration → Transmitter Display → Display Variables
Field communicator	Configure → Manual Setup → Display → Decimal Places

You can specify the number of decimal places (precision) that are shown on the display for each process variable or diagnostic variable. You can set the precision independently for each variable.

The display precision does not affect the actual value of the variable or the value used in calculations.

**Procedure**

1. Select a variable.
2. Set **Number of Decimal Places** to the number of decimal places you want shown when the process variable or diagnostic variable appears on the display.

For temperature and density process variables, the default value is 2 decimal places. For all other variables, the default value is 4 decimal places. The range is 0 to 5.

**Tip**

The lower the precision, the greater the change must be for it to be reflected on the display. Do not set the precision too low or too high to be useful.

## 9.1.4 Configure the refresh rate of data shown on the display

ProLink III	Device Tools → Configuration → Transmitter Display → Display Variables
Field communicator	Configure → Manual Setup → Display → Display Behavior → Refresh Rate

You can set **Refresh Rate** to control how frequently data is refreshed on the display.

**Procedure**

Set **Refresh Rate** to the desired value.

The default value is 1000 milliseconds. The range is 100 milliseconds to 10,000 milliseconds (10 seconds).

## 9.1.5 Enable or disable automatic scrolling through the display variables

ProLink III	Device Tools → Configuration → Transmitter Display → General
Field communicator	Configure → Manual Setup → Display → Display Behavior → Auto Scroll

You can configure the display to automatically scroll through the configured display variables or to show a single display variable until the operator activates **Scroll**. When you set automatic scrolling, you can also configure the length of time each display variable is displayed.

**Procedure**

1. Enable or disable **Auto Scroll** as desired.

Option	Description
Enabled	The display automatically scrolls through each display variable as specified by <b>Scroll Rate</b> . The operator can move to the next display variable at any time using <b>Scroll</b> .
Disabled	Default. The display shows <b>Display Variable 1</b> and does not scroll automatically. The operator can move to the next display variable at any time using <b>Scroll</b> .

2. If you enabled **Auto Scroll**, set **Scroll Rate** as desired.  
The default value is 10 seconds.

**Tip**  
Scroll Rate may not be available until you apply Auto Scroll.

## 9.2 Enable or disable the Acknowledge All Alerts display command

ProLink III	Device Tools → Configuration → Transmitter Display → Ack All
Field communicator	Configure → Manual Setup → Display → Display Menus → Acknowledge All

You can configure whether or not the operator can use a single command to acknowledge all alerts from the display.

### Procedure

1. Ensure that the alert menu is accessible from the display.  
To acknowledge alerts from the display, operators must have access to the alert menu.
2. Enable or disable **Acknowledge All Alerts** as desired.

Option	Description
Enabled	Default. Operators can use a single display command to acknowledge all alerts at once.
Disabled	Operators cannot acknowledge all alerts at once. Each alert must be acknowledged separately.

## 9.3 Configure security for the display menus

ProLink III	Device Tools → Configuration → Transmitter Display → Display Security
Field communicator	Configure → Manual Setup → Display → Display Menus

You can control operator access to different sections of the display off-line menu. You can also configure a passcode to control access.

### Procedure

1. To control operator access to the maintenance section of the off-line menu, enable or disable **Off-Line Menu**.

Option	Description
Enabled	Default. Operator can access the maintenance section of the off-line menu. This access is required for configuration and calibration, including Known Density Verification.
Disabled	Operator cannot access the maintenance section of the off-line menu.

2. To control operator access to the alert menu, enable or disable **Alert Menu**.

Option	Description
Enabled	Default. Operator can access the alert menu. This access is required to view and acknowledge alerts, but is not required for Known Density Verification, configuration, or calibration.
Disabled	Operator cannot access the alert menu.

**Note**

The transmitter status LED changes color to indicate that there are active alerts, but does not show specific alerts.

- To require a passcode for access to the off-line menu, enable or disable **Off-Line Password**.

Option	Description
Enabled	Operator is prompted for the off-line passcode at entry to the off-line menu.
Disabled	Default. No passcode is required for entry to the off-line menu.

- Set **Off-Line Password** to the desired value.

The default value is 1234. The range is 0000 to 9999.

**Tip**

Record your passcode for future reference.

## 9.4 Configure alert handling

The alert handling parameters control the transmitter's response to process and device conditions.

### 9.4.1 Configure Fault Timeout

ProLink III	Device Tools → Configuration → Fault Processing
Field communicator	Configure → Alert Setup → Alert Severity → Fault Timeout

**Fault Timeout** controls the delay before fault actions are performed.

**Restriction**

**Fault Timeout** is applied only to the following alerts (listed by Status Alert Code): A003, A004, A008, A016, A033. For all other alerts, fault actions are performed as soon as the alert is detected.

**Procedure**

- Set **Fault Timeout** as desired.

The default value is 0 seconds. The range is 0 to 60 seconds.

If you set **Fault Timeout** to 0, fault actions are performed as soon as the alert condition is detected.

The fault timeout period begins when the transmitter detects an alert condition. During the fault timeout period, the transmitter continues to report its last valid measurements.



If the fault timeout period expires while the alert is still active, the fault actions are performed. If the alert condition clears before the fault timeout expires, no fault actions are performed.

## 9.4.2 Configure Alert Severity

ProLink III	Device Tools → Configuration → Alert Severity
Field communicator	Configure → Alert Setup → Alert Severity → Change Alert Severity

Use **Alert Severity** to control the fault actions that the transmitter performs when it detects an alert condition.

### Restriction

- For some alerts, **Alert Severity** is not configurable.
- For some alerts, **Alert Severity** can be set only to two of the three options.

### Tip

Micro Motion recommends using the default settings for **Alert Severity** unless you have a specific requirement to change them.

### Procedure

1. Select a status alert.
2. For the selected status alert, set **Alert Severity** as desired.

Option	Description
Fault	<p>Actions when fault is detected:</p> <ul style="list-style-type: none"> <li>• The alert is posted to the Alert List.</li> <li>• Outputs go to the configured fault action (after <b>Fault Timeout</b> has expired, if applicable).</li> <li>• Digital communications go to the configured fault action (after <b>Fault Timeout</b> has expired, if applicable).</li> <li>• The status LED (if available) changes to red or yellow (depending on alert severity).</li> </ul> <p>Actions when alert clears:</p> <ul style="list-style-type: none"> <li>• Outputs return to normal behavior.</li> <li>• Digital communications return to normal behavior.</li> <li>• The status LED returns to green.</li> </ul>
Informational	<p>Actions when fault is detected:</p> <ul style="list-style-type: none"> <li>• The alert is posted to the Alert List.</li> <li>• The status LED (if available) changes to red or yellow (depending on alert severity).</li> </ul> <p>Actions when alert clears:</p> <ul style="list-style-type: none"> <li>• The status LED returns to green.</li> </ul>
Ignore	No action

## Status alerts and options for Status Alert Severity

Alert number	Alert title	Default severity	User can reset severity
A001	EEPROM Error	Fault	No
A002	RAM Error	Fault	No
A003	No Sensor Response	Fault	Yes
A004	Temperature Overrange	Fault	No
A006	Characterization Required	Fault	Yes
A008	Density Overrange	Fault	Yes
A009	Transmitter Initializing/Warming Up	Ignore	Yes
A010	Calibration Failure	Fault	No
A014	Transmitter Failure	Fault	No
A016	Sensor Temperature (RTD) Failure	Fault	Yes
A020	Calibration Factors Missing	Fault	Yes
A021	Transmitter/Sensor/Software Mismatch	Fault	No
A029	Internal Electronics Failure	Fault	No
A030	Incorrect Board Type	Fault	No
A033	Insufficient Pickoff Signal	Fault	Yes
A037	Sensor Check Failed	Fault	Yes
A038	Time Period Signal Out of Range	Fault	No
A100	mA Output 1 Saturated	Informational	To Informational or Ignore only
A101	mA Output 1 Fixed	Informational	To Informational or Ignore only
A102	Drive Overrange	Informational	Yes
A104	Calibration in Progress	Informational	To Informational or Ignore only
A106	Burst Mode Enabled	Informational	To Informational or Ignore only
A107	Power Reset Occurred	Informational	Yes
A113	mA Output 2 Saturated	Informational	To Informational or Ignore only
A114	mA Output 2 Fixed	Informational	To Informational or Ignore only
A115	No External Input or Polled Data	Informational	To Informational or Ignore only
A118	Discrete Output 1 Fixed	Informational	To Informational or Ignore only

Alert number	Alert title	Default severity	User can reset severity
A120	Curve Fit Failure (Concentration)	Informational	No
A132	Sensor Simulation Active	Informational	Yes
A133	EEPROM Error (Display)	Informational	Yes
A136	Incorrect Display Type	Informational	Yes

## 9.5 Configure informational parameters

ProLink III	Device Tools → Configuration → Meter Information
Field communicator	Configure → Manual Setup → Info Parameters

The informational parameters can be used to identify or describe your meter. They are not used in process measurement and they are not required.

### Procedure

Enter data as desired.

Parameter	Description
<b>Meter Serial Number</b>	The serial number of the device. Enter the value from the device tag.
<b>Message</b>	A message to be stored in device memory. The message can contain up to 32 characters.
<b>Descriptor</b>	A description of this device. The description can contain up to 16 characters.
<b>Date</b>	A static date (not updated by the meter). Enter the date in the form <code>mm/dd/yyyy</code> .
<b>Flange Type</b>	The sensor flange type for this device. Obtain the value from the documents shipped with the device or from a code in the model number.

### Tip

- A field communicator will not support all informational parameters. If you need to configure all of the informational parameters, use ProLink III.
- A field communicator will allow you to configure **HART Tag** and **HART Long Tag** from this location. These parameters are replicated from **Configure → Manual Setup → HART → Communications**. These parameters are used in HART communications.



# 10 Integrate the meter with the control system

## 10.1 Configure Channel B

ProLink III	Device Tools → Configuration → I/O → Channels
Field communicator	Configure → Manual Setup → Inputs/Outputs → Channels → Channel B

Depending on your device, you can configure Channel B to operate as either an mA output or a discrete output.

### Prerequisites

The configuration of Channel B must match the wiring. See the installation manual for your device.

To avoid causing process errors:

- Configure Channel B before configuring the mA output or discrete output.
- Before changing the channel configuration, ensure that all control loops affected by the channel are under manual control.

### Restriction

You cannot configure Channel B on the following devices: SGM TPS or SGM Fixed. On these devices, Channel B always operates as a TPS output.

### Procedure

Set Channel B as desired.

Option	Description
mA output	Channel B will operate as the secondary mA Output.
Discrete output	Channel B will operate as a discrete output.

## 10.2 Configure the mA Output

The mA Output is used to report the configured process variable. The mA Output parameters control how the process variable is reported.

The SGM mA device has two mA Outputs: Channel A and Channel B. Both outputs are fully configurable.

The SGM DO device has one mA Output: Channel A. The output is fully configurable.

The SGM TPS device has one mA Output: Channel A. The output is fully configurable.

The SGM Fixed device has one mA Output: Channel A. The output is not configurable.

**Important**

Whenever you change an mA output parameter, verify all other mA Output parameters before returning the meter to service. In some situations, the transmitter automatically loads a set of stored values, and these values may not be appropriate for your application.

## 10.2.1 Configure mA Output Process Variable

ProLink III	Device Tools → Configuration → I/O → Outputs → mA Output → mA Output 1 → Source
	Device Tools → Configuration → I/O → Outputs → mA Output → mA Output 2 → Source
Field communicator	Configure → Manual Setup → Inputs/Outputs → mA Output 1 → Primary Variable
	Configure → Manual Setup → Inputs/Outputs → mA Output 2 → Secondary Variable

Use **mA Output Process Variable** to select the variable that is reported over the mA Output.

**Prerequisites**

If you are using the HART variables, be aware that changing the configuration of **mA Output Process Variable** will change the configuration of the HART Primary Variable (PV) and/or the HART Secondary Variable (SV).

**Procedure**

Set **mA Output Process Variable** as desired.

Default settings are shown in the following table.

**Table 10-1: Default settings for mA Output Process Variable**

Device	Channel	mA Output	Default process variable assignment
SGM mA	Channel A	Primary mA Output	Specific gravity, relative density, or molecular weight
	Channel B	Secondary mA Output	Temperature
SGM DO	Channel A	Primary mA Output	Specific gravity, relative density, or molecular weight
SGM TPS	Channel A	Primary mA Output	Temperature
SGM Fixed	Channel A	Primary mA Output	Temperature <sup>(1)</sup>

(1) Not configurable.

**Postrequisites**

If you changed the setting of **mA Output Process Variable**, verify the settings of **Lower Range Value (LRV)** and **Upper Range Value (URV)**.

## Options for mA Output Process Variable

The transmitter provides a basic set of options for **mA Output Process Variable**, plus several application-specific options. Different communications tools may use different labels for the options.

Process variable	Label		
	Display	ProLink III	Field communicator
<b>Standard</b>			
Line Density	DENS	Line Density	Density
Sample Temperature	TEMP	Sample Temperature	Temperature
Line Temperature (External or Fixed)	EXT T	Line Temperature (External or Fixed)	External Temperature
Line Pressure (External or Fixed)	EXT P	Line Pressure (External or Fixed)	External Pressure
Volume Flow Rate (External)	MAG V	Volume Flow Rate (External)	Volume from Mag/Vortex Meter
Mass Flow Rate (Calculated)	MAG M	Mass Flow Rate (Calculated)	Calculated Mass Flow from Mag Meter Input
Mass Flow Rate (External)	COR M	Mass Flow Rate (External)	Mass from Coriolis Meter
Volume Flow Rate (Calculated)	COR V	Volume Flow Rate (Calculated)	Volume Flow at Reference Temperature
Drive Gain	DGAIN	Drive Gain	Drive Gain
Sensor Time Period	TP B	Sensor Time Period	Sensor Time Period
User-Defined Calculation Output	UCALC	User-Defined Calculation Output	User-Defined Calculation Output
<b>Concentration measurement</b>			
Concentration	CONC	Concentration	Concentration (CM)
Net Mass Flow Rate	NET M	Net Mass Flow Rate	Net Mass Flow Rate (CM)
Net Volume Flow Rate	NET V	Net Volume Flow Rate	Net Volume Flow Rate (CM)
<b>Gas measurement</b>			
Base Density	BDENS	Base Density (Gas)	Base Density (Gas)
Specific Gravity	SG	Specific Gravity (Gas)	Specific Gravity (Gas)
Relative Density	RD	Relative Density (Gas)	Relative Density
Molecular Weight	MW	Molecular Weight (Gas)	Molecular Weight
%CO <sub>2</sub>	CO2	%CO <sub>2</sub>	Percent CO <sub>2</sub>
%H <sub>2</sub>	N2	%H <sub>2</sub>	Percent H <sub>2</sub>
%N <sub>2</sub>	H2	%N <sub>2</sub>	Percent N <sub>2</sub>
%CO	CO	%CO	Percent CO
<b>Energy measurement</b>			
Calorific Value	CV	Calorific Value	Calorific Value

Process variable	Label		
	Display	ProLink III	Field communicator
Wobbe Index	WOBBE	Wobbe Index	Wobbe Index
Energy Flow	ENRGY	Energy Flow	Energy Flow

## 10.2.2 Configure Lower Range Value (LRV) and Upper Range Value (URV)

ProLink III	Device Tools → Configuration → I/O → Outputs → mA Output → mA Output 1 → Lower Range Value
	Device Tools → Configuration → I/O → Outputs → mA Output → mA Output 1 → Upper Range Value
	Device Tools → Configuration → I/O → Outputs → mA Output → mA Output 2 → Lower Range Value
	Device Tools → Configuration → I/O → Outputs → mA Output → mA Output 2 → Upper Range Value
Field communicator	Configure → Manual Setup → Inputs/Outputs → mA Output 1 → mA Output Settings → PV LRV
	Configure → Manual Setup → Inputs/Outputs → mA Output 1 → mA Output Settings → PV URV
	Configure → Manual Setup → Inputs/Outputs → mA Output 2 → mA Output Settings → SV LRV
	Configure → Manual Setup → Inputs/Outputs → mA Output 2 → mA Output Settings → SV URV

The **Lower Range Value (LRV)** and **Upper Range Value (URV)** are used to scale the mA Output, that is, to define the relationship between **mA Output Process Variable** and the mA Output level.

### Prerequisites

Ensure that **mA Output Process Variable** is set to the desired process variable. Each process variable has its own set of LRV and URV values. When you change the values of LRV and URV, you are configuring values for the currently assigned mA Output process variable.

Ensure that the measurement unit for the configured process variable has been set as desired.

### Procedure

Set LRV and URV as desired.

- LRV is the value of **mA Output Process Variable** represented by an output of 4 mA. The default value for LRV depends on the setting of **mA Output Process Variable**. Enter LRV in the measurement units that are configured for **mA Output Process Variable**.
- URV is the value of **mA Output Process Variable** represented by an output of 20 mA. The default value for URV depends on the setting of **mA Output Process Variable**. Enter URV in the measurement units that are configured for **mA Output Process Variable**.

### Tip

For best performance:

- Set  $LRV \geq LSL$  (lower sensor limit).
- Set  $URV \leq USL$  (upper sensor limit).
- Set these values so that the difference between URV and LRV is  $\geq$  Min Span (minimum span).

Defining URV and LRV within the recommended values for **Min Span**, **LSL**, and **USL** ensures that the resolution of the mA Output signal is within the range of the bit precision of the D/A converter.



**Note**

You can set **URV** below **LRV**. For example, you can set **URV** to 50 and **LRV** to 100.

The mA Output uses a range of 4–20 mA to represent **mA Output Process Variable**. Between **LRV** and **URV**, the mA Output is linear with the process variable. If the process variable drops below **LRV** or rises above **URV**, the transmitter posts an output saturation alert.

### 10.2.3 Configure Added Damping

ProLink III	Device Tools → Configuration → I/O → Outputs → mA Output → mA Output 1 → Added Damping
	Device Tools → Configuration → I/O → Outputs → mA Output → mA Output 2 → Added Damping
Field communicator	Configure → Manual Setup → Inputs/Outputs → mA Output 1 → mA Output Settings → PV Added Damping
	Configure → Manual Setup → Inputs/Outputs → mA Output 2 → mA Output Settings → SV Added Damping

**Added Damping** controls the amount of damping that will be applied to the mA output.

Damping is used to smooth out small, rapid fluctuations in process measurement. **Damping Value** specifies the time period (in seconds) over which the transmitter will spread changes in the process variable. At the end of the interval, the internal value will reflect 63% of the change in the actual measured value.

**Added Damping** affects the reporting of **mA Output Process Variable** through the mA output only. It does not affect the reporting of that process variable via any other method (e.g., a frequency output or digital communications), or the value of the process variable used in calculations.

**Note**

**Added Damping** is not applied if the mA output is fixed (for example, during loop testing) or if the mA output is reporting a fault. **Added Damping** is applied while sensor simulation is active.

**Procedure**

Set **Added Damping** to the desired value.

The default value is 0.0 seconds. The range is 0.0 to 440 seconds.

When you specify a value for **Added Damping**, the transmitter automatically rounds the value down to the nearest valid value.

### Interaction between mA Output Damping and process variable damping

When **mA Output Process Variable** is set to one of the primary process variables (specific gravity, molecular weight, or relative density), or to temperature, **Added Damping** interacts with **Density Damping** or **Temperature Damping**.

**Damping interaction**

Configuration:

- **mA Output Process Variable** = Specific Gravity (Gas)
- **Density Damping** = 1 second
- **Added Damping** = 2 seconds

Result: A change in specific gravity will be reflected in the mA output over a time period that is greater than 3 seconds. The exact time period is calculated by the transmitter according to internal algorithms which are not configurable.

## 10.2.4 Configure mA Output Fault Action and mA Output Fault Level

ProLink III	Device Tools → Configuration → I/O → Outputs → mA Output → mA Output 1 → Fault Action
	Device Tools → Configuration → I/O → Outputs → mA Output → mA Output 2 → Fault Action
Field communicator	Configure → Manual Setup → Inputs/Outputs → mA Output 1 → mA01 Fault Settings → MA01 Fault Action
	Configure → Manual Setup → Inputs/Outputs → mA Output 2 → MA02 Fault Settings → MA02 Fault Action

**mA Output Fault Action** controls the behavior of the mA output if the transmitter encounters an internal fault condition.

### Note

For some faults only: If **Fault Timeout** is set to a non-zero value, the transmitter will not implement the fault action until the timeout has elapsed.

### Procedure

1. Set **mA Output Fault Action** to the desired value.  
The default setting is Downscale.

### Restriction

If **Digital Communications Fault Action** is set to NAN (not a number), you cannot set **mA Output Fault Action** to None. If you try to do this, the device will not accept the configuration.

2. If you set **mA Output Fault Action** to Upscale or Downscale, set **mA Output Fault Level** as desired.

### Postrequisites

### NOTICE

If you set **mA Output Fault Action** to None, be sure to set **Digital Communications Fault Action** to None. If you do not, the output will not report actual process data, and this may result in measurement errors or unintended consequences for your process.

## Options for mA Output Fault Action and mA Output Fault Level

Option	mA Output behavior	mA Output Fault Level
Upscale	Goes to the configured fault level	Default: 21.5 mA Range: 21.0 to 21.5 mA
Downscale (default)	Goes to the configured fault level	Default: 3.2 mA Range: 3.2 to 3.6 mA

Option	mA Output behavior	mA Output Fault Level
Internal Zero	Goes to the mA Output level associated with a process variable value of 0 (zero), as determined by <b>Lower Range Value</b> and <b>Upper Range Value</b> settings	Not applicable
None	Tracks data for the assigned process variable; no fault action	Not applicable

## 10.3 Configure the Discrete Output

The Discrete Output is used to report specific meter or process conditions. The Discrete Output parameters control which condition is reported and how it is reported. Depending on your purchase option, your transmitter may have one Discrete Output or no Discrete Outputs.

### Important

Whenever you change a Discrete Output parameter, verify all other Discrete Output parameters before returning the meter to service. In some situations, the transmitter automatically loads a set of stored values, and these values may not be appropriate for your application.

### 10.3.1 Configure Discrete Output Source

ProLink III	Device Tools → Configuration → I/O → Outputs → Discrete Output
Field communicator	Configure → Manual Setup → Inputs/Outputs → Discrete Output → DO Source

**Discrete Output Source** controls which device condition or process condition is reported via the Discrete Output.

### Procedure

Set **Discrete Output Source** to the desired option.

The default setting for **Discrete Output Source** is Fault.

### Options for Discrete Output Source

Option	Label		State	Discrete Output voltage
	ProLink III	Field communicator		
Enhanced Event 1–5	Enhanced Event 1	Enhanced Event 1	ON	Site-specific
	Enhanced Event 2	Enhanced Event 2	OFF	0 V
Calibration in Progress	Enhanced Event 3	Enhanced Event 3		
	Enhanced Event 4	Enhanced Event 4		
	Enhanced Event 5	Enhanced Event 5		
Calibration in Progress	Calibration in Progress	Calibration in Progress	ON	Site-specific
			OFF	0 V
Fault (default)	Fault Indicator	Fault	ON	Site-specific
			OFF	0 V

**Important**

This table assumes that **Discrete Output Polarity** is set to Active High. If **Discrete Output Polarity** is set to Active Low, reverse the voltage values.

## 10.3.2 Configure Discrete Output Polarity

ProLink III	Device Tools → Configuration → I/O → Outputs → Discrete Output
Field communicator	Configure → Manual Setup → Inputs/Outputs → Discrete Output → DO Polarity

Discrete outputs have two states: ON (active) and OFF (inactive). Two different voltage levels are used to represent these states. **Discrete Output Polarity** controls which voltage level represents which state.

**Procedure**

Set **Discrete Output Polarity** as desired.

The default setting is Active High.

### Options for Discrete Output Polarity

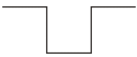
Polarity	Description
Active High 	<ul style="list-style-type: none"> <li>When asserted (condition tied to DO is true), the circuit draws as much current as it can, up to a maximum of 10 mA.</li> <li>When not asserted (condition tied to DO is false), the circuit draws less than 1 mA.</li> </ul>
Active Low 	<ul style="list-style-type: none"> <li>When asserted (condition tied to DO is true), the circuit draws less than 1 mA.</li> <li>When not asserted (condition tied to DO is false), the circuit draws as much current as it can, up to a maximum of 10 mA.</li> </ul>

## 10.3.3 Configure Discrete Output Fault Action

ProLink III	Device Tools → Configuration → Fault Processing
Field communicator	Configure → Manual Setup → Inputs/Outputs → Discrete Output → DO Fault Action

**Discrete Output Fault Action** controls the behavior of the Discrete Output if the transmitter encounters an internal fault condition.

**Note**

For some faults only: If **Fault Timeout** is set to a non-zero value, the transmitter will not implement the fault action until the timeout has elapsed.

 **CAUTION**

Do not use **Discrete Output Fault Action** as a fault indicator. If you do, you may not be able to distinguish a fault condition from a normal operating condition. If you want to use the Discrete Output as a fault indicator, set **Discrete Output Source** to Fault and set **Discrete Output Fault Action** to None.

**Procedure**

Set **Discrete Output Fault Action** as desired.

The default setting is None.

**Options for Discrete Output Fault Action**

Label	Discrete Output behavior	
	Polarity=Active High	Polarity=Active Low
Upscale	<ul style="list-style-type: none"> <li>Fault: Discrete Output is ON (site-specific voltage)</li> <li>No fault: Discrete Output is controlled by its assignment</li> </ul>	<ul style="list-style-type: none"> <li>Fault: Discrete Output is OFF (0 V)</li> <li>No fault: Discrete Output is controlled by its assignment</li> </ul>
Downscale	<ul style="list-style-type: none"> <li>Fault: Discrete Output is OFF (0 V)</li> <li>No fault: Discrete Output is controlled by its assignment</li> </ul>	<ul style="list-style-type: none"> <li>Fault: Discrete Output is ON (site-specific voltage)</li> <li>No fault: Discrete Output is controlled by its assignment</li> </ul>
None (default)	Discrete Output is controlled by its assignment	

**Fault indication with the Discrete Output**

To indicate faults via the Discrete Output, set **Discrete Output Source** to Fault. Then, if a fault occurs, the Discrete Output is always ON and the setting of **Discrete Output Fault Action** is ignored.

**10.4 Configure an enhanced event**

ProLink III	Device Tools → Configuration → Events → Enhanced Events
Field communicator	Configure → Alert Setup → Enhanced Events

An enhanced event is used to provide notification of process changes. An enhanced event occurs (is ON) if the real-time value of a user-specified process variable moves above (HI) or below (LO) a user-defined setpoint, or in range (IN) or out of range (OUT) with respect to two user-defined setpoints. You can define up to five enhanced events.

**Procedure**

1. Select the event that you want to configure.
2. Specify **Event Type**.

Option	Description
HI	$x > A$ The event occurs when the value of the assigned process variable ( $x$ ) is greater than the setpoint ( <b>Setpoint A</b> ), endpoint not included.
LO	$x < A$

Option	Description
	The event occurs when the value of the assigned process variable ( $x$ ) is less than the setpoint ( <b>Setpoint A</b> ), endpoint not included.
IN	$A \leq x \leq B$ The event occurs when the value of the assigned process variable ( $x$ ) is <i>in range</i> , that is, between <b>Setpoint A</b> and <b>Setpoint B</b> , endpoints included.
OUT	$x \leq A$ or $x \geq B$ The event occurs when the value of the assigned process variable ( $x$ ) is <i>out of range</i> , that is, less than <b>Setpoint A</b> or greater than <b>Setpoint B</b> , endpoints included.

3. Assign a process variable to the event.
4. Set values for the required setpoints.
  - For HI and LO events, set **Setpoint A**.
  - For IN and OUT events, set **Setpoint A** and **Setpoint B**.
5. Optional: Configure a Discrete Output to switch states in response to the event status.

### Related information

[Configure Discrete Output Source](#)

## 10.5 Configure HART/Bell 202 communications

HART/Bell 202 communications parameters support HART communications with the transmitter's primary mA terminals over a HART/Bell 202 network.

### 10.5.1 Configure basic HART parameters

ProLink III	Device Tools → Configuration → Meter Information Device Tools → Configuration → Communications → Communications (HART)
Field communicator	Configure → Manual Setup → HART → Communications

Basic HART parameters include the HART address, HART tags, and the operation of the primary mA output.

#### Restriction

- Your device supports HART 7. If you are using HART 5, **HART Long Tag** is not available.
- **HART Tag**, **HART Long Tag**, and **mA Output Action** are not configurable from the display.

#### Procedure

1. Set **HART Address** to a unique value on your network.  
Valid address values are between 0 and 15. The default address (0) is typically used unless you are in a multidrop environment.

**Tip**

Devices using HART protocol to communicate with the transmitter may use either **HART Address** or **HART Tag (Software Tag)** to identify the transmitter. Configure either or both, as required by your other HART devices.

2. Set **HART Long Tag** to a unique value on your network.
3. Ensure that **mA Output Action** is configured appropriately.

Option	Description
Enabled (Live)	The primary mA Output reports process data as configured. This is the appropriate setting for most applications.
Disabled (Fixed)	The primary mA Output is fixed at 4 mA and does not report process data.

**Important**

If you use ProLink III to set **HART Address** to 0, the program automatically enables **mA Output Action**. If you use ProLink III to set **HART Address** to any other value, the program automatically disables **mA Output Action**. This is designed to make it easier to configure the transmitter for legacy behavior. Always verify **mA Output Action** after setting **HART Address**.

## 10.5.2 Configure HART variables (PV, SV, TV, QV)

ProLink III	Device Tools → Configuration → Communications → Communications (HART)
Field communicator	Configure → Manual Setup → Inputs/Outputs → Variable Mapping

The HART variables are a set of four variables predefined for HART use. The HART variables include the Primary Variable (PV), Secondary Variable (SV), Tertiary Variable (TV), and Quaternary Variable (QV). You can assign specific process variables to the HART variables, and then use standard HART methods to read or broadcast the assigned process data.

**Tip**

The Tertiary Variable and Quaternary Variable are also called the Third Variable (TV) and Fourth Variable (FV).

**Restriction**

On some devices, the PV is fixed to a specific process variable and cannot be changed.

### Options for HART variables

Process variable	Primary Variable (PV)	Secondary Variable (SV)	Third Variable (TV)	Fourth Variable (QV)
<b>Standard</b>				
Line Density	✓	✓	✓	✓
Sample Temperature	✓	✓	✓	✓
Sample Temperature (External or Fixed)	✓	✓	✓	✓
Line Pressure (External or Fixed)	✓	✓	✓	✓

Process variable	Primary Variable (PV)	Secondary Variable (SV)	Third Variable (TV)	Fourth Variable (QV)
Volume Flow Rate (External)	✓	✓	✓	✓
Volume Flow Rate (Calculated)	✓	✓	✓	✓
Mass Flow Rate (External)	✓	✓	✓	✓
Mass Flow Rate (Calculated)	✓	✓	✓	✓
Drive Gain	✓	✓	✓	✓
Sensor Time Period	✓	✓	✓	✓
User-Defined Calculation Output	✓	✓	✓	✓
Board Temperature			✓	✓
Input Voltage			✓	✓
<b>Concentration</b>				
Concentration	✓	✓	✓	✓
Net Mass Flow Rate	✓	✓	✓	✓
Net Volume Flow Rate	✓	✓	✓	✓
<b>Gas measurement</b>				
Base Density (Gas)	✓	✓	✓	✓
Specific Gravity (Gas)	✓	✓	✓	✓
Relative Density (Gas)	✓	✓	✓	✓
Molecular Weight (Gas)	✓	✓	✓	✓
Compressibility			✓	✓
%CO <sub>2</sub>	✓	✓	✓	✓
%H <sub>2</sub>	✓	✓	✓	✓
%N <sub>2</sub>	✓	✓	✓	✓
%CO	✓	✓	✓	✓
<b>Energy measurement</b>				
Calorific Value	✓	✓	✓	✓
Wobbe Index	✓	✓	✓	✓
Energy Flow	✓	✓	✓	✓

## Interaction of HART variables and transmitter outputs

The HART variables are automatically reported through specific transmitter outputs. They may also be reported through HART burst mode, if enabled on your transmitter.

### Restriction

On some devices, the PV and the primary mA output are fixed to a specific process variable and cannot be changed.



**Table 10-2: HART variables and transmitter outputs**

HART variable	Reported via	Comments
Primary Variable (PV)	Primary mA Output	If one assignment is changed, the other is changed automatically, and vice versa.
Secondary Variable (SV)	Secondary mA Output, if present on your transmitter	If you have a secondary mA output: If one assignment is changed, the other is changed automatically. If you do not have a secondary mA output: The SV must be configured directly, and the value of the SV is available only via digital communications.
Tertiary Variable (TV)	Not associated with an output	The TV must be configured directly, and the value of the TV is available only via digital communications.
Quaternary Variable (QV)	Not associated with an output	The QV must be configured directly, and the value of the QV is available only via digital communications.

### 10.5.3 Configure burst communications

*Burst mode* is a mode of communication during which the transmitter regularly broadcasts HART digital information to the network via the primary mA Output.

**Restriction**

Burst communications, including trigger mode and event notification, are not available on HART/RS-485. These features are supported only on HART/Bell 202.

### Configure HART burst messages

ProLink III	Device Tools → Configuration → Communications → Communications (HART)
Field communicator	Configure → Manual Setup → HART → Burst Mode

Burst messages contain information on process variables or transmitter status. You can configure up to three burst messages. Each message can contain different information. Burst messages also provide the mechanism for trigger mode and event notification.

**Restriction**

If you are using a HART 5 host, only one burst message is supported.

**Procedure**

1. Navigate to the burst message you want to configure.
2. Enable the burst message.
3. Set **Burst Option** to the desired content.

**Table 10-3: Options for burst message contents**

HART command	Label		Description
	ProLink III	Field communicator	
1	Source (Primary Variable)	Primary Variable	The transmitter sends the primary variable (PV) in the configured measurement units in each burst message (e.g., 14.0 g/sec, 13.5 g/sec, 12.0 g/sec).

**Table 10-3: Options for burst message contents (continued)**

HART command	Label		Description
	ProLink III	Field communicator	
2	Primary Variable (Percent Range/Current)	Pct Range/Current	The transmitter sends the PV's actual mA level and the PV's percent of range in each burst message (e.g., 11.0 mA 25%).
3	Process Variables/Current	Process Vars/Current	The transmitter sends the PV's actual milliamp reading and the PV, SV, TV, and QV values in measurement units in each burst message (e.g., 11.8 mA, 50 g/sec, 23 °C, 50 g/sec, 0.0023 g/cm <sup>3</sup> ).
9	Read Device Variables with Status	Device Variables with Status	The transmitter sends up to eight user-specified process variables in each burst message.
33	Transmitter Variables	Field Device Vars	The transmitter sends four user-specified process variables in each burst message.
48	Read Additional Transmitter Status	Read Additional Device Status	The transmitter sends expanded device status information in each burst message.

- Depending on your choice, select the four or eight user-specified variables for the burst message, or set the HART variables as desired.

**Important**

If you change the HART Primary Variable (PV) or Secondary Variable (SV), the process variables assigned to the primary mA Output and the secondary mA Output (if applicable) are automatically changed to match. The PV cannot be changed on devices with fixed mA Output assignments.

**Configure HART trigger mode**

ProLink III	Device Tools → Configuration → Communications → Communications (HART)
Field communicator	Configure → Manual Setup → HART → Burst Mode → Burst Message x → Configure Update Rate

*Trigger mode* uses the burst message mechanism to indicate that a process variable has changed. When trigger mode is implemented, the bursting interval (HART update rate) changes if Primary Variable or Burst Variable 0 moves above or below the user-specified trigger level. You can set up a different trigger on each burst message.

**Prerequisites**

Before you can configure trigger mode, the corresponding HART burst message must be enabled.

**Restriction**

This feature is available only with a HART 7 host.

**Procedure**

- Select the burst message for which you will set up trigger mode.
- Set **Trigger Mode** to the type of trigger you want to use.

Option	Description
Continuous	The burst message is sent at <b>Default Update Rate</b> . The burst interval is not affected by changes in process variables.
Falling	<ul style="list-style-type: none"> <li>When the specified process variable is above <b>Trigger Level</b>, the burst message is sent at <b>Default Update Rate</b>.</li> <li>When the specified process variable is below <b>Trigger Level</b>, the burst message is sent at <b>Update Rate</b>.</li> </ul>
Rising	<ul style="list-style-type: none"> <li>When the specified process variable is below <b>Trigger Level</b>, the burst message is sent at <b>Default Update Rate</b>.</li> <li>When the specified process variable is above <b>Trigger Level</b>, the burst message is sent at <b>Update Rate</b>.</li> </ul>
Windowed	<p>This option is used to communicate that the process variable is changing rapidly. <b>Trigger Level</b> defines a deadband around the most recently broadcast value.</p> <ul style="list-style-type: none"> <li>If the process variable stays within this deadband, the burst message is sent at <b>Default Update Rate</b>.</li> <li>If the process variable moves outside this deadband in either direction, the burst message is sent at <b>Update Rate</b>.</li> </ul>
On Change	<ul style="list-style-type: none"> <li>If any value in the burst message changes, the burst message is sent at <b>Update Rate</b>.</li> <li>If no values change, the burst message is sent at <b>Default Update Rate</b>.</li> </ul>

3. Ensure that **Primary Variable** or **Burst Variable 0** is set to the variable that will activate the trigger. If it is not, reconfigure the burst message contents.
4. Set **Trigger Level** to the value of the process variable at which the trigger will be activated.
5. Set **Default Update Rate** to the burst interval to be used when the trigger is not active.
6. Set **Update Rate** to the burst interval to be used when the trigger is active.

## Configure HART event notification

ProLink III	Device Tools → Configuration → Communications → Communications (HART) → Event Notification
Field communicator	Configure → Manual Setup → HART → Event Notification

*Event notification* uses the burst message mechanism to indicate that an alert has occurred. When event notification is enabled and one or more of the selected alerts occurs, each active burst message will broadcast HART Command 119 until the condition is acknowledged by a HART master.

### Prerequisites

If you are using a field communicator, you must enable a burst message before you can configure event notification.

### Tip

Event notification affects only HART burst messages. Whether an alert is selected for event notification or not, alert severity, alert status (active or inactive), fault timeout, and alert acknowledgment operate as normal.

**Restriction**

This feature is available only with a HART 7 host.

**Procedure**

1. Enable event notification.
2. Select all desired alerts.

If one or more of the selected alerts occurs, each active burst message will broadcast HART Command 119 until the alert is acknowledged by a HART master.

3. Set **Trigger Interval** as desired.

**Trigger Interval** controls the delay before HART Command 119 is broadcast.

- Default: 0 seconds
- Range: 0.5 to 3600 seconds

**Trigger Interval** begins when the transmitter detects the alert condition. When **Trigger Interval** expires:

- If the alert is still active, HART Command 119 is broadcast.
- If the alert is not active, no message is broadcast.

**Tip**

If you set **Trigger Interval** to 0, HART Command 119 is broadcast as soon as the alert is detected.

4. Set **Retry Rate** as desired.

**Retry Rate** controls the rate at which HART Command 119 is broadcast when event notification is active.

- Default: 0.5 seconds

5. Set **Maximum Update Time** as desired.

**Maximum Update Time** controls the rate at which HART Command 119 is broadcast when event notification is not active.

- Default: 60 seconds

## 10.6 Configure Modbus communications

ProLink III	Device Tools → Configuration → Communications → Communications (Modbus)
Field communicator	Not available

Modbus communications parameters control Modbus communications with the transmitter.

Modbus support is implemented on the RS-485 physical layer via the RS-485 terminals.

**Important**

Your device automatically accepts all connection requests within the following ranges:

- Protocol: Modbus RTU (8-bit) or Modbus ASCII (7-bit) unless **Modbus ASCII Support** is disabled

- Parity: odd or even
- Stop bits: 1 or 2
- Baud: 1200, 2400, 4800, 9600, 19200, 38400

You do not need to configure these communications parameters on the device.

**Procedure**

1. Enable or disable **Modbus ASCII Support** as desired.

The setting of this parameter controls the range of valid Modbus addresses for your device.

Modbus ASCII support	Available Modbus addresses
Disabled	1–127, excluding 111 (111 is reserved to the service port)
Enabled	1–15, 32–47, 64–79, and 96–110

2. Set **Modbus Address** to a unique value on the network.
3. Set **Floating-Point Byte Order** to match the byte order used by your Modbus host.

Code	Byte order
0	1–2 3–4
1	3–4 1–2
2	2–1 4–3
3	4–3 2–1

See the following table for the bit structure of bytes 1, 2, 3, and 4.

**Table 10-4: Bit structure of floating-point bytes**

Byte	Bits	Definition
1	SEEEEEEE	S=Sign E=Exponent
2	EMMMMMMM	E=Exponent M=Mantissa
3–4	MMMMMMMM	M=Mantissa

4. Optional: Set **Additional Communications Response Delay** in *delay units*.

A delay unit is 2/3 of the time required to transmit one character, as calculated for the port currently in use and the character transmission parameters.

**Additional Communications Response Delay** is used to synchronize Modbus communications with hosts that operate at a slower speed than the device. The value specified here will be added to each response the device sends to the host.

- Default: 0
- Range: 0 to 255

**Tip**

Do not set **Additional Communications Response Delay** unless required by your Modbus host.

## 10.7 Configure Digital Communications Fault Action

ProLink III	Device Tools → Configuration → Fault Processing
Field communicator	Configure → Alert Setup → I/O Fault Actions → Digital Communication Fault Action

**Digital Communications Fault Action** specifies the values that will be reported via digital communications if the device encounters an internal fault condition.

**Procedure**

Set **Digital Communications Fault Action** as desired.

The default setting is None.

**Restriction**

- If **mA Output Fault Action** is set to None, **Digital Communications Fault Action** should also be set to None. If you do not, the output will not report actual process data, and this may result in measurement errors or unintended consequences for your process.
- If you set **Digital Communications Fault Action** to NAN, you cannot set **mA Output Fault Action** to None. If you try to do this, the transmitter will not accept the configuration.

### 10.7.1 Options for Digital Communications Fault Action

Label		Description
ProLink III	Field communicator	
Upscale	Upscale	Process variable values indicate that the value is greater than the upper sensor limit.
Downscale	Downscale	Process variable values indicate that the value is lower than the lower sensor limit.
Zero	IntZero-All 0	<ul style="list-style-type: none"> <li>• Density is reported as 0.</li> <li>• Temperature is reported as 0 °C, or the equivalent if other units are used (e.g., 32 °F).</li> <li>• Drive gain is reported as measured.</li> </ul>
Not a Number	Not-a-Number	<ul style="list-style-type: none"> <li>• Process variables are reported as IEEE NAN.</li> <li>• Drive gain is reported as measured.</li> <li>• Modbus scaled integers are reported as Max Int.</li> </ul>
None	None (default)	All process variables are reported as measured.

# 11 Complete the configuration

## 11.1 Test or tune the system using sensor simulation

ProLink III	Device Tools → Diagnostics → Testing → Sensor Simulation
Field communicator	Service Tools → Simulate → Simulate Sensor

Use sensor simulation to test the system's response to a variety of process conditions, including boundary conditions, problem conditions, or alert conditions, or to tune the loop.

### Procedure

1. Enable sensor simulation.
2. Set the process variables to the desired test values.
3. Observe the system response to the simulated values and make any appropriate changes to the transmitter configuration or to the system.
4. Modify the simulated values and repeat.
5. When you have finished testing or tuning, disable sensor simulation.

## 11.2 Back up transmitter configuration

ProLink III provides a configuration upload/download function which allows you to save configuration sets to your PC. This allows you to back up and restore your transmitter configuration. This is also a convenient way to replicate a configuration across multiple devices.

### Restriction

This function is not available with any other communications tools.

### Procedure

1. Choose **Device Tools** → **Configuration Transfer** → **Save or Load Configuration Data**.
2. In the **Configuration** group box, select the configuration data you want to save.
3. Select **Save**, then specify a file name and location on your computer.
4. Select **Start Save**.

The backup file is saved to the specified name and location. It is saved as a text file and can be read using any text editor.

## 11.3 Enable HART security

When HART security is enabled, HART protocol cannot be used to write any data to the device. This prevents changes to configuration via HART. It does not prevent changes to configuration using any other protocol or method.

### Prerequisites

- Strap wrench

- 3 mm hex key

---

**Tip**

Do not enable HART security unless it is specifically required for your meter. Most installations do not enable HART security.

---

**Procedure**

1. Power down the meter.
  2. Using the strap wrench, loosen the grub screws and remove the transmitter end-cap.
- 

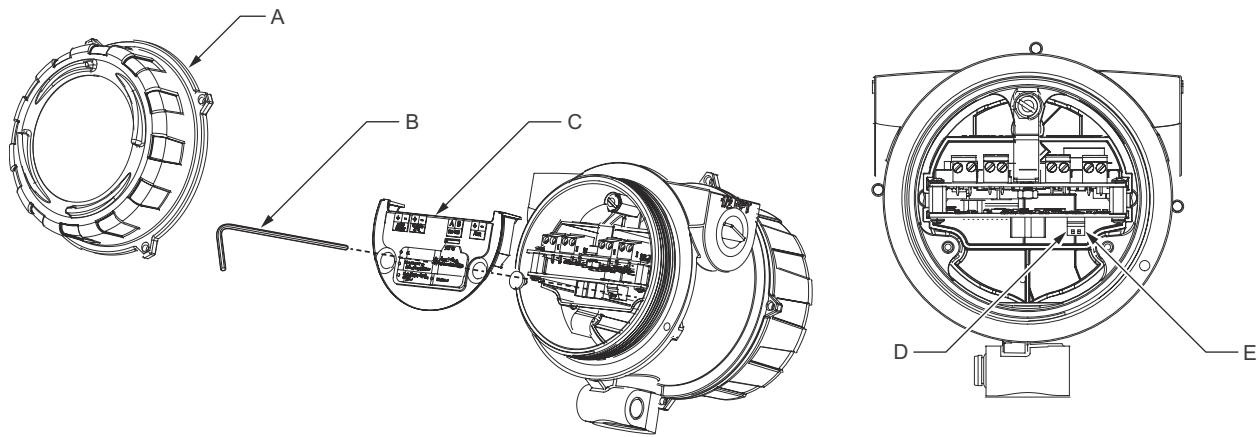
**Figure 11-1: Transmitter with end-cap and safety spacer removed**

- A. Transmitter end-cap
  - B. 3 mm hex key
  - C. Safety spacer
  - D. HART security switch
  - E. Unused
- 

3. Use the hex key to loosen the two retaining screws and remove the safety spacer.
4. Move the HART security switch to the ON position (down).  
The HART security switch is the switch on the left.
5. Replace the safety spacer and end-cap.
6. Power up the meter.



## 12 Transmitter operation

### 12.1 Record the process variables

Micro Motion suggests that you make a record of specific process variable measurements, including the acceptable range of measurements, under normal operating conditions. This data will help you recognize when the process or diagnostic variables are unusually high or low, and may help you diagnose and troubleshoot application issues.

#### Procedure

Record the following process and diagnostic variables, under normal operating conditions.

Variable	Measurement		
	Typical average	Typical high	Typical low
Specific Gravity, Molecular Weight, or Relative Density			
Sample Temperature			
Line Pressure			
Sensor Time Period			
Pickoff Voltage			
Drive Gain			

### 12.2 View process variables and diagnostic variables

Process variables provide information about the state of the process fluid. Diagnostic variables provide data about meter operation. This information can be used to understand and troubleshoot your process.

#### 12.2.1 View process variables and other data using ProLink III

Monitor process variables, diagnostic variables, and other data to maintain process quality.

ProLink III automatically displays process variables, diagnostic variables, and other data on the main screen.

#### Tip

ProLink III allows you to choose the process variables that appear on the main screen. You can also choose whether to view data in Analog Gauge view or digital view, and you can customize the gauge settings. For more information, see the *Micro Motion ProLink III with ProcessViz Software User Manual*.

#### 12.2.2 View process variables using a field communicator

Monitor process variables to maintain process quality.

#### Procedure

- To view current values of basic process variables, choose **Overview**.

- To view a more complete set of process variables, plus the current state of the outputs, choose **Service Tools** → **Variables**.

## 12.3 View and acknowledge status alerts

The transmitter posts status alerts whenever a process variable exceeds its defined limits or the transmitter detects a fault condition. You can view active alerts, and you can acknowledge alerts. Acknowledging alerts is not required.

### 12.3.1 View and acknowledge alerts using the display

You can view a list containing all alerts that are active, or inactive but unacknowledged.

#### Prerequisites

Operator access to the alert menu must be enabled (default setting). If operator access to the alert menu is disabled, you must use another method to view or acknowledge status alerts.

---

#### Note

Only Fault and Informational alerts are listed. The transmitter automatically filters out alerts with **Status Alert Severity** set to Ignore.

---

#### Procedure

See [Figure 12-1](#).

Figure 12-1: Using the display to view and acknowledge the status alerts

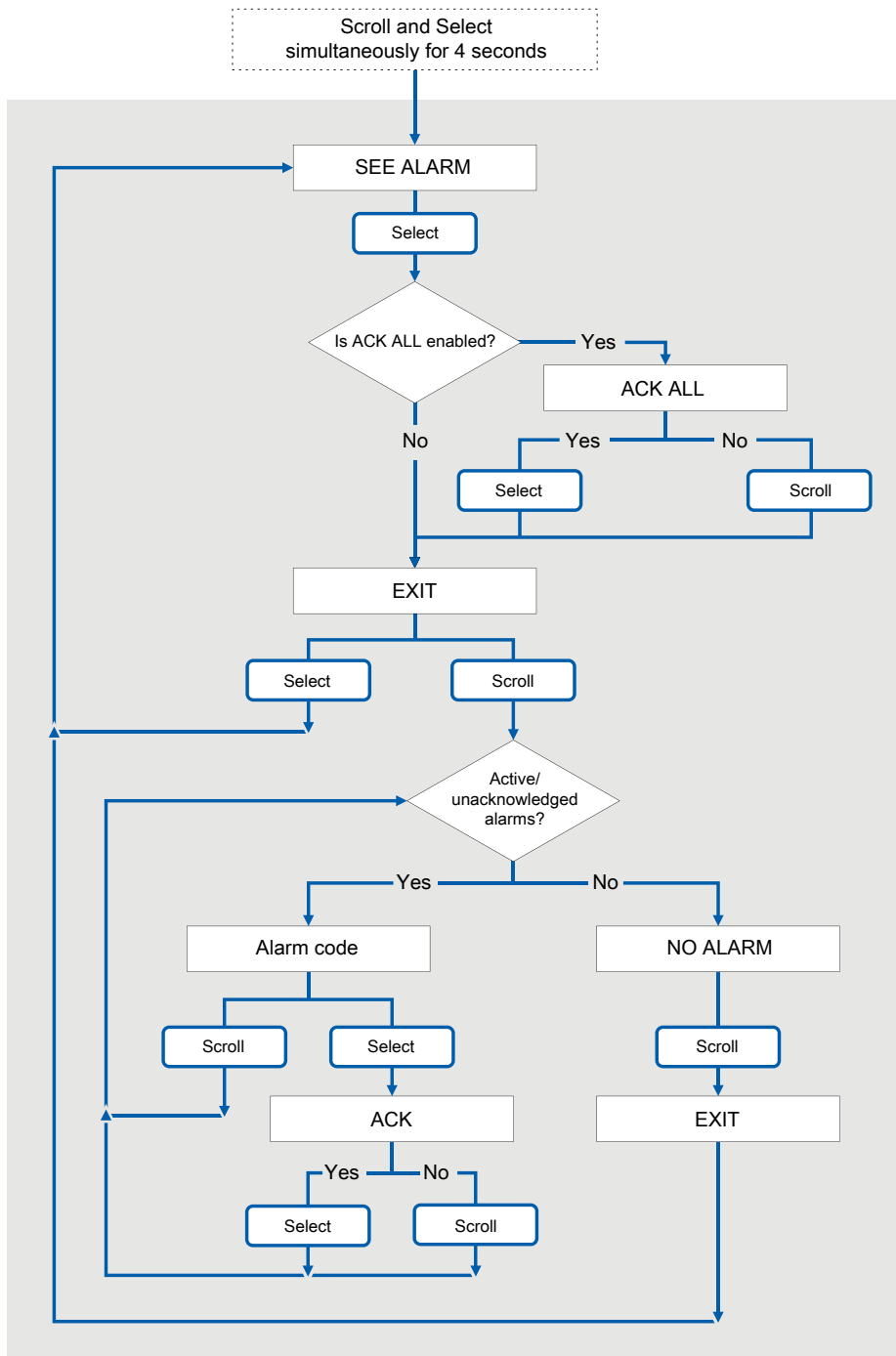

### Postrequisites

- To clear A010, A011, A012, A013 alerts, you must correct the problem, acknowledge the alert, then repeat the calibration.
- To clear A001, A002, A029, A031 alerts, you must correct the problem, acknowledge the alert, then power-cycle the transmitter.
- For all other alerts:
  - If the alert is inactive when it is acknowledged, it will be removed from the list.
  - If the alert is active when it is acknowledged, it will be removed from the list when the alert condition clears.

## 12.3.2 View and acknowledge alerts using ProLink III

You can view a list containing all alerts that are active, or inactive but unacknowledged. From this list, you can acknowledge individual alerts or choose to acknowledge all alerts at once.

### Procedure

1. View alerts on the ProLink III main screen under **Alerts**. If the alerts are not displayed, choose **Device Tools** → **Alerts**.

All active or unacknowledged alerts are listed, and displayed according to the following categories:

Category	Description
<b>Failed: Fix Now</b>	A meter failure has occurred and must be addressed immediately.
<b>Maintenance: Fix Soon</b>	A condition has occurred that can be fixed at a later time.
<b>Advisory: Informational</b>	A condition has occurred, but requires no maintenance from you.

### Notes

- All fault alerts are displayed in the **Failed: Fix Now** category.
- All information alerts are displayed in either the **Maintenance: Fix Soon** category or the **Advisory: Informational** category. The category assignment is hard-coded.
- The transmitter automatically filters out alerts with **Alert Severity** set to Ignore.

2. To acknowledge a single alert, check the **Ack** checkbox for that alert. To acknowledge all alerts at once, click **Ack All**.

### Postrequisites

- To clear A010, A011, A012, A013 alerts, you must correct the problem, acknowledge the alert, then repeat the calibration.
- To clear A001, A002, A029, A031 alerts, you must correct the problem, acknowledge the alert, then power-cycle the transmitter.
- For all other alerts:
  - If the alert is inactive when it is acknowledged, it will be removed from the list.

- If the alert is active when it is acknowledged, it will be removed from the list when the alert condition clears.

### 12.3.3 View alerts using a field communicator

You can view a list containing all alerts that are active, or inactive but unacknowledged.

#### Procedure

- To view active or unacknowledged alerts, choose **Service Tools** → **Alerts**.

All active alerts and unacknowledged alerts are listed.

---

#### Note

Only Fault and Informational alerts are listed. The transmitter automatically filters out alerts with **Status Alert Severity** set to Ignore.

---

- To refresh the list, choose **Service Tools** → **Alerts** → **Refresh Alerts**.



## 13 Measurement support

### 13.1 Adjust temperature measurement with Temperature Offset or Temperature Slope

You can adjust the sample temperature measurement by modifying the value for **Temperature Offset** or **Temperature Slope**. The measured temperature value is always multiplied by the temperature slope. The temperature offset is always added to the result.

Micro Motion does not recommend adjusting the sample temperature because the RTD sensor is located inside the measurement chamber. Typically, the sample temperature is different from the process temperature, and attempting to adjust this variable on the field can cause significant accuracy errors.

#### Prerequisites

You will need an external temperature measurement method that is highly accurate.

Ensure that your process is stable during the sampling procedure. Minimize variation in density, temperature, flow rate, and fluid composition. Minimize aeration.

Meter-specific temperature calibration factors are determined at the factory. These values are available on the meter tag. **Temperature Offset** and **Temperature Slope** are applied after the temperature calibration factors.

The default value for **Temperature Offset** is 0. The default value for **Temperature Slope** is 1.0. Accordingly, the default values have no effect on the reported temperature value.

---

#### Note

Temperature offset and temperature slope are applied only to temperature data from the on-board temperature sensors (internal RTD). External temperature data is not adjusted.

---

#### Tip

Although you can set **Temperature Offset** or **Temperature Slope** manually, the temperature calibration procedure will generate a pair of offset and slope values that are more accurate for the individual meter. However, temperature calibration can be difficult. Consult Micro Motion before performing a temperature calibration.

---

#### Procedure

1. Take a temperature reading from the meter.
2. Immediately after the previous step, take a sample from a location as close to the meter as possible.
3. Using the external measurement method, measure the temperature of the sample.
4. Use the following equation to calculate an appropriate value for **Temperature Offset** or **Temperature Slope**.

$$t_{Sample} = TemperatureSlope \times (\rho_{Sample} + TemperatureOffset)$$

---

#### Tip

In most cases, you will set only one parameter. Follow the guidelines established for your site.

---

5. If you are using the offset to adjust temperature measurement, set **Temperature Offset** to the calculated value.
  - Using ProLink III: **Device Tools** → **Configuration** → **Process Measurement** → **Sample Temperature** → **Temperature Offset**

- Using a field communicator: Not available

The default value is 0. The range is unlimited.

6. If you are using the slope to adjust temperature measurement, set **Temperature Slope** to the calculated value.
  - Using ProLink III: **Device Tools** → **Configuration** → **Process Measurement** → **Sample Temperature** → **Temperature Slope**

- Using a field communicator: Not available

The default value is 1.0. The recommended range is 0.8 to 1.2. If your calculated slope is outside this range, contact customer service.

## 13.2 Adjust concentration measurement with Trim Offset

**Trim Offset** adjusts the meter's concentration measurement to match a reference value.

### Tip

You can adjust concentration measurement by applying the trim offset only, or by applying both the trim offset and the trim slope. For most applications, the trim offset is sufficient.

### Prerequisites

Ensure that the active matrix is the one that you want to trim. You can set the offset separately for each matrix on your transmitter.

### Procedure

1. Take a concentration reading from the meter, and record line density and sample temperature.
2. Subtract the meter value from a reference device.
3. Enter the result as the trim offset.
  - Using ProLink III: Choose **Device Tools** → **Configuration** → **Process Measurement** → **Concentration Measurement**, set **Matrix Being Configured** to your matrix, and enter **Trim Offset**.
  - Using a field communicator: **Configure** → **Manual Setup** → **Measurements** → **Conc Measure (CM)** → **Trim CM Process Variables** → **Concentration Offset**
4. Take another concentration reading from the meter, and compare it to the laboratory value.
  - If the two values are acceptably close, the trim is complete.
  - If the two values are not acceptably close, repeat this procedure.

### Calculating the trim offset

Laboratory value	64.21 %
------------------	---------



Meter value	64.93 %
-------------	---------

Concentration offset: -0.72

## 13.3 Adjust concentration measurement with Trim Slope and Trim Offset

**Trim Slope** and **Trim Offset** adjust the meter's concentration measurement to match a reference value.

### Tip

You can adjust concentration measurement by applying the trim offset only, or by applying both the trim offset and the trim slope. For most applications, the trim offset is sufficient.

### Prerequisites

- Ensure that the active matrix is the one that you want to trim. You can set the offset and slope separately for each matrix on your transmitter.
- For each sample, you must be able to obtain a laboratory concentration value at line density and sample temperature.

### Procedure

1. Collect data for Comparison 1.
  - a) Take a concentration reading from the meter and record line density and sample temperature.
  - b) Subtract the meter value from a reference device.
  - c) Obtain a laboratory value for concentration at line density and sample temperature, in the units used by the meter.
2. Collect data for Comparison 2.
  - a) Change the concentration of your process fluid.
  - b) Take a concentration reading from the meter and record line density and sample temperature.
  - c) Subtract the meter value from a reference device.
  - d) Obtain a laboratory value for concentration at line density and sample temperature, in the units used by the meter.
3. Populate the following equation with values from each comparison.
 
$$\text{Concentration}_{\text{Lab}} = (A \times \text{Concentration}_{\text{Meter}}) + B$$
4. Solve for A (slope).
5. Solve for B (offset), using the calculated slope and one set of values.
6. Enter the results as the trim slope and the trim offset.
  - Using ProLink III: Choose **Device Tools** → **Configuration** → **Process Measurement** → **Concentration Measurement**, set **Matrix Being Configured** to your matrix, and enter **Trim Slope** and **Trim Offset**.

- Using a field communicator: **Configure** → **Manual Setup** → **Measurements** → **Conc Measure (CM)** → **Trim CM Process Variables**
7. Take another concentration reading from the meter, and compare it to the laboratory value.
- If the two values are acceptably close, the trim is complete.
  - If the two values are not acceptably close, repeat this procedure.

### Calculating the trim slope and the trim offset

Comparison 1	Laboratory value	50.00%
	Meter value	49.98%
Comparison 2	Laboratory value	16.00%
	Meter value	15.99%

Populate the equations:

$$50 = (A \times 49.98) + B$$

$$16 = (A \times 15.99) + B$$

Solve for A:

$$50.00 - 16.00 = 34.00$$

$$49.98 - 15.99 = 33.99$$

$$34 = A \times 33.99$$

$$A = 1.00029$$

Solve for B:

$$50.00 = (1.00029 \times 49.98) + B$$

$$50.00 = 49.99449 + B$$

$$B = 0.00551$$

Concentration slope (A): 1.00029

Concentration offset (B): 0.00551

## 13.4 Set up user-defined calculations

ProLink III	Device Tools → Configuration → User-Defined Calculations
Field communicator	Configure → Manual Setup → Measurements → Optional Setup → User-Defined Calculations

User-defined calculations are used to enhance measurement or to adapt the meter to special process conditions.

A user-defined calculation allows you to create a new process variable by inserting constants and existing process variables into an equation. The output of the equation is the new process variable. Depending on your meter, either two or three equations are available.

### Procedure

- Select the user-defined calculation that you want to use.

2. If you selected User-Defined Calculation 1:
  - a) Enter the values to be used for the constants: A, B, X, Y.
  - b) Enter the values to be used for  $a$ ,  $b$ ,  $c$ ,  $d$ ,  $e$ , and  $f$ .

For these terms:

- You can specify a constant value.
- You can specify a process variable. If you choose this, the current value of the process variable is used in the calculation.

---

**Important**

User-defined calculations are performed using the meter's internal measurement units. Therefore:

- If a constant represents a process variable, you must enter its value in the internal measurement units.
- If a constant will be used to modify a process variable, you must use the internal measurement units to derive the constant.

- 
3. If you selected User-Defined Calculation 2:
    - a) Enter the values to be used for the constants: A, B, C.
    - b) Enter the value to be used for  $t$ .

For this term:

- You can specify a constant value.
- You can specify a process variable. If you choose this, the current value of the process variable is used in the calculation.

---

**Important**

User-defined calculations are performed using the meter's internal measurement units. Therefore:

- If a constant represents a process variable, you must enter its value in the internal measurement units.
- If a constant will be used to modify a process variable, you must use the internal measurement units to derive the constant.

- 
4. Enter a label to be used for the output of the user-defined calculation (the new process variable).
  5. Optional: Set up a reporting method for the new process variable.

The new process variable can be configured as a display variable or a HART variable, or assigned to an mA output. It can also be read using digital communications.

---

**Important**

The output of the user-defined calculation is based on internal measurement units for process variables. You may need to convert this value to the configured units before using it in your application or process.

---

## 13.4.1 Equations used in user-defined calculations

Each user-defined calculation has an equation and a set of user-programmable constants and/or user-specified process variables.

### User-defined calculation 1 (square root)

$$y = A + B \times \left( \frac{a \times (b + (X \times c))}{d \times (e + (Y \times \sqrt{f}))} \right)$$

<b>A, B, X, Y</b>	User-programmable constants
<b>a, b, c, d, e, f</b>	User-programmable constants or user-specified process variables
<b>y</b>	Result of calculation

### User-defined calculation 2 (exponential)

$$y = e^{(A + (B \times t) + (C \times t^2))}$$

<b>e</b>	Natural logarithm
<b>A, B, C</b>	User-programmable constants
<b>t</b>	User-programmable constant or user-specified process variable
<b>y</b>	Result of calculation

## 13.4.2 Measurement units used in user-defined calculations

The meter's internal measurement units are used for all process variables referenced by a user-defined calculation. All constants must be entered in the internal measurement units or derived using the internal measurement units.

**Table 13-1: Process variables and internal measurement units**

Process variable	Internal measurement unit
Density	g/cm <sup>3</sup>
Referred Density	g/cm <sup>3</sup>
Relative Density	g/cm <sup>3</sup>
Molecular Weight	g/mol
Calorific Value	MJ/kg
Mass Flow (external or calculated)	kg/sec
Volume Flow (external or calculated)	l/sec
Energy Flow	MJ/sec
Sample Temperature	°C
External Temperature	°C
Board Temperature	°C
Drive Gain	%

**Table 13-1: Process variables and internal measurement units (continued)**

<b>Process variable</b>	<b>Internal measurement unit</b>
Concentration	%
% CO, % CO <sub>2</sub> , %N <sub>2</sub> , %H <sub>2</sub>	%
Line Pressure	Bar a
Sensor Time Period	Microseconds
Specific Gravity (gas)	Unitless
Specific Gravity (concentration measurement)	Unitless
Compressibility	Unitless
CII	Unitless
CCAI	Unitless
Quality Factor	Unitless
Wobbe Index	Unitless



# 14 Troubleshooting

## 14.1 Quick guide to troubleshooting

The meter may report or exhibit issues that are caused by installation, wiring, configuration, and process problems — including external devices, or mechanical issues with the sensor itself.

To identify and resolve problems as effectively as possible, work through the following list of suggestions:

- If this is a first installation:
  - Verify the power wiring and power supply.
  - Verify the output wiring. The outputs must be powered externally.
  - Verify the grounding.
  - Verify cable shielding.
  - Perform loop tests for each output.
  - Check the sensor installation and orientation. Ensure that it is appropriate for your application.
  - Ensure that the installation meets temperature and/or pressure requirements.
- Check for active status alerts and follow the recommendations.
- If the device appears to be functioning correctly, but the process data is not acceptable, review the symptoms and suggestions in the following sections:
  - Density measurement problems
  - Temperature measurement problems
  - Gas measurement problems
  - Concentration measurement problems
- If the device appears to be functioning correctly, but the control loop is not performing as expected:
  - Verify the output wiring.
  - Ensure that all external devices are operational, are receiving data, and are configured appropriately.
  - Use sensor simulation to test boundary conditions and system response.

## 14.2 Verify performance

Use this section to verify SGM performance by flowing the calibration gases through the system to ensure that the meter is providing an accurate measurement.

**Figure 14-1: Typical SGM installation**

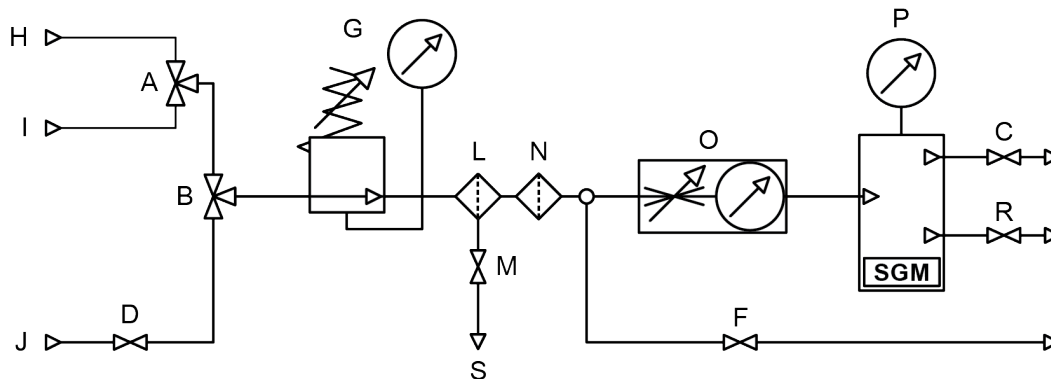

- A. Calibration gas selector three-way valve
- B. Process/Calibration gas selector three-way valve
- C. Outlet two-way valve
- D. Process gas inlet two-way valve
- E. Chamber fill valve
- F. Purge two-way valve
- G. Pressure regulator with gauge
- H. Calibration gas 1 inlet
- I. Calibration gas 2 inlet
- J. Process gas sampling point
- K. Tubing work (not shown in diagram)
- L. Coalescent filter
- M. Coalescent filter drain two-way valve
- N. Particle filter
- O. Flow meter
- P. Transmitter
- Q. Reference chamber pressure indicator
- R. Relief valve
- S. Drain

### 14.2.1 Verify low calibration gas

#### Procedure

1. Close the process gas inlet valve (D).
2. Set the process/calibration selector valve (B) to the calibration position.
3. Connect the lower calibration gas to the calibration gas 1 inlet (H).
4. Set the pressure regulator on the lower calibration gas to the appropriate sample pressure for your installation.



5. Set the calibration gas selector valve to the calibration gas 1 inlet (H) position and make sure the outlet valve (C) remains open.
6. While the gas is flowing through the system, observe the primary variable measurement (specific gravity, molecular weight, or relative density). After approximately 5 minutes, verify that the variable reading is the same as the expected value for the calibration gas that is flowing (calibration gas 1).

### Postrequisites

Once the measurement has been verified, verify calibration gas 2 in [Verify high calibration gas](#).

## 14.2.2 Verify high calibration gas

### Procedure

1. Connect the higher calibration gas to the calibration gas 2 inlet (I).
2. Set the pressure regulator on the higher calibration gas to the appropriate sample pressure for your installation.
3. Set the calibration gas selector valve (A) to the calibration gas 2 inlet (I) position.
4. While the gas is flowing through the system, observe the primary variable measurement (specific gravity, molecular weight, or relative density). After approximately 5 minutes, verify that the variable reading is the same as the expected value for the calibration gas that is flowing (calibration gas 2).

### Postrequisites

Once both calibration gases have been verified, put the system back into service in [Finish verification](#).

## 14.2.3 Finish verification

Once both calibration gases have been verified, use this procedure to put the system back into service.

### Procedure

1. Disconnect the calibration gases.
2. Set the process/calibration selector valve to the process gas position.
3. Open the process gas inlet valve.

### Postrequisites

If one or both calibration gases failed, do one of the following tasks:

- [Perform the Known Density Verification procedure](#)
- [Purge and purge-cycle the SGM device](#)

## 14.3 Perform the Known Density Verification procedure

The Known Density Verification procedure is used to verify that the meter's current operation matches the factory baseline. If the meter passes the test, the meter does not have any physical problems such as denting, bending, twisting, erosion, or corrosion.

### Restriction

Known Density Verification is not available on the Fixed Outputs version (Transmitter Output Options, code E).

### Prerequisites

Check calibration integrity inline first by running a known gas through the system using the factory measurements. Verify that the reported density is correct. If it is not correct, continue with a KDV check and the following prerequisites.

1. Minimize variation in ambient temperature.
2. Eliminate or minimize vibration.
3. Power down the meter.
4. Use a vacuum pump to empty the meter. Pull a vacuum inside the meter to a maximum pressure of 0.2 Torr.
5. Power up the meter.

## 14.3.1 Perform the Known Density Verification procedure using ProLink III

### Procedure

1. Read the Prerequisites in [Perform the Known Density Verification procedure](#) if you have not done so already.
2. Choose **Device Tools** → **Diagnostics** → **Known Density Verification**.
3. Optional: Enter identification data.
4. Select **Start**, then wait while the meter collects and analyzes process data.  
This step should be complete in approximately 20 seconds.
5. Check the results in the **Results** data display.
  - If all process variables passed the tests, no action is required. Click **Close** to exit the wizard.
  - If one or more process variables failed the test:
    - For problems with Line Temperature, verify that the ambient temperature of the meter is stable, and that the meter temperature has stabilized in the test location. Then retry the Known Density Verification procedure.
    - For problems with Verification Time Period Signal or Drive Gain, ensure that the meter is clean and dry. Then retry the Known Density Verification procedure.
    - If the Known Density Verification procedure continues to fail, contact customer service.

## 14.3.2 Perform the Known Density Verification procedure using a field communicator

### Procedure

1. Read the Prerequisites in [Perform the Known Density Verification procedure](#) if you have not done so already.
2. Choose **Service Tools** → **Maintenance** → **Verification** → **Known Density Verification**.
3. Select **Next** to start the procedure.

4. Wait while the meter collects and analyzes process data.  
This step should be complete in approximately 20 seconds.
5. Check the results in the **Results** data display.
  - If all process variables passed the tests, no action is required. Select **Close** to exit the wizard.
  - If one or more process variables failed the test:
    - For problems with Line Temperature, verify that the ambient temperature of the meter is stable, and that the meter temperature has stabilized in the test location. Then retry the Known Density Verification procedure.
    - For problems with Verification Time Period Signal or Drive Gain, ensure that the meter is clean and dry. Then retry the Known Density Verification procedure.
    - If the Known Density Verification procedure continues to fail, contact customer service.

## 14.4 Check power supply wiring

If the power supply wiring is damaged or improperly connected, the transmitter may not receive enough power to operate properly.

### Prerequisites

You will need the installation manual for your transmitter.

### Procedure

1. Use a voltmeter to test the voltage at the transmitter's power supply terminals.
  - If the voltage is within the specified range, you do not have a power supply problem.
  - If the voltage is low, ensure that the power supply is adequate at the source, the power cable is sized correctly, there is no damage to the power cable, and an appropriate fuse is installed.
  - If there is no power, continue with this procedure.
2. Before inspecting the power supply wiring, disconnect the power source.

#### CAUTION

If the transmitter is in a hazardous area, wait five minutes after disconnecting the power.

3. Ensure that the terminals, wires, and wiring compartment are clean and dry.
4. Ensure that the power supply wires are connected to the correct terminals.
5. Ensure that the power supply wires are making good contact, and are not clamped to the wire insulation.
6. Reapply power to the transmitter.

#### CAUTION

If the transmitter is in a hazardous area, do not reapply power to the transmitter with the housing cover removed. Reapplying power to the transmitter while the housing cover is removed could cause an explosion.

7. Test the voltage at the terminals.

If there is no power, contact customer service.

## 14.5 Check grounding

The sensor and the transmitter must be grounded.

### Procedure

Refer to the sensor and transmitter installation manuals for grounding requirements and instructions.

## 14.6 Perform loop tests

A loop test is a way to verify that the transmitter and the remote device are communicating properly. A loop test also helps you know whether you need to trim mA Outputs.

### Related information

[Perform loop tests using the display](#)

[Perform loop tests using ProLink III](#)

[Perform loop tests using a field communicator](#)

### 14.6.1 Perform loop tests using the display

#### Prerequisites

Before performing a loop test, configure the channels for the transmitter inputs and outputs that will be used in your application.

Follow appropriate procedures to ensure that loop testing will not interfere with existing measurement and control loops.

#### Procedure

1. Test the mA outputs.
  - a) Choose **OFFLINE MAINT** → **SIM** → **AO1 SIM** or **OFFLINE MAINT** → **SIM** → **AO2 SIM**, and select a low value, e.g., 4 mA.  
Dots traverse the display while the output is fixed.
  - b) Read the mA current at the receiving device and compare it to the transmitter output.  
The readings do not need to match exactly. If the values are slightly different, you can correct the discrepancy by trimming the output.
  - c) At the transmitter, activate **Select**.
  - d) Scroll to and select a high value, e.g., 20 mA.  
Dots traverse the display while the output is fixed.
  - e) Read the mA current at the receiving device and compare it to the transmitter output.  
The readings do not need to match exactly. If the values are slightly different, you can correct the discrepancy by trimming the output.

- f) At the transmitter, activate **Select**.
2. Test the discrete outputs.
    - a) Choose **OFFLINE MAINT** → **SIM** → **DO SIM**, and select **SET ON**.

Dots traverse the display while the output is fixed.
    - b) Verify the signal at the receiving device.
    - c) At the transmitter, activate **Select**.
    - d) Scroll to and select **SET OFF**.
    - e) Verify the signal at the receiving device.
    - f) At the transmitter, activate **Select**.
  3. Test the TPS output.
    - a) Attach a frequency counter, oscilloscope, digital multimeter (DMM), or digital voltmeter (DVM) to the TPS output loop.
    - b) Compare the reading to the Sensor Time Period process variable at your meter.

### Postrequisites

- If the mA Output readings are within 200 microamps of each other, you can correct this discrepancy by trimming the output.
- If the discrepancy between the mA Output readings is greater than 200 microamps, or if at any step the reading was faulty, verify the wiring between the transmitter and the remote device, and try again.
- If the Discrete Output readings are reversed, check the setting of **Discrete Output Polarity**.
- If the TPS output readings do not match, contact customer service.

## 14.6.2 Perform loop tests using ProLink III

### Prerequisites

Before performing a loop test, configure the channels for the transmitter inputs and outputs that will be used in your application.

Follow appropriate procedures to ensure that loop testing will not interfere with existing measurement and control loops.

### Procedure

1. Test the mA Outputs.
  - a) Choose **Device Tools** → **Diagnostics** → **Testing** → **mA Output 1 Test** or **Device Tools** → **Diagnostics** → **Testing** → **mA Output 2 Test**.
  - b) Enter 4 in **Fix to:**.
  - c) Click **Fix mA**.
  - d) Read the mA current at the receiving device and compare it to the transmitter output.

The readings do not need to match exactly. If the values are slightly different, you can correct the discrepancy by trimming the output.

- e) Click **UnFix mA**.
- f) Enter 20 in **Fix to:**.
- g) Click **Fix mA**.
- h) Read the mA current at the receiving device and compare it to the transmitter output.

The readings do not need to match exactly. If the values are slightly different, you can correct the discrepancy by trimming the output.

- i) Click **UnFix mA**.

## 2. Test the discrete outputs.

- a) Choose **Device Tools** → **Diagnostics** → **Testing** → **Discrete Output Test**.
- b) Set **Fix To:** to ON.
- c) Verify the signal at the receiving device.
- d) Set **Fix To:** to OFF.
- e) Verify the signal at the receiving device.
- f) Click **UnFix**.

## 3. Test the TPS output.

- a) Attach a frequency counter, oscilloscope, digital multimeter (DMM), or digital voltmeter (DVM) to the TPS output loop.
- b) Compare the reading to the Sensor Time Period process variable at your meter.

### Postrequisites

- If the mA Output readings are within 200 microamps of each other, you can correct this discrepancy by trimming the output.
- If the discrepancy between the mA Output readings is greater than 200 microamps, or if at any step the reading was faulty, verify the wiring between the transmitter and the remote device, and try again.
- If the Discrete Output readings are reversed, check the setting of **Discrete Output Polarity**.
- If the TPS output readings do not match, contact customer service.

## 14.6.3 Perform loop tests using a field communicator

### Prerequisites

Before performing a loop test, configure the channels for the transmitter inputs and outputs that will be used in your application.

Follow appropriate procedures to ensure that loop testing will not interfere with existing measurement and control loops.

## Procedure

1. Test the mA outputs.
  - a) Choose **Service Tools** → **Simulate** → **Simulate Outputs** → **mA Output 1 Loop Test** or **Service Tools** → **Maintenance** → **Simulate Outputs** → **mA Output 2 Loop Test**, and select **4 mA**.
  - b) Read the mA current at the receiving device and compare it to the transmitter output.  
The readings do not need to match exactly. If the values are slightly different, you can correct the discrepancy by trimming the output.
  - c) Press **OK**.
  - d) Select **20 mA**.
  - e) Read the mA current at the receiving device and compare it to the transmitter output.  
The readings do not need to match exactly. If the values are slightly different, you can correct the discrepancy by trimming the output.
  - f) Press **OK**.
  - g) Choose **End**.
2. Test the Discrete Outputs.
  - a) Press **Service Tools** → **Simulate** → **Simulate Outputs** → **Discrete Output Loop Test**.
  - b) Choose **Off**.
  - c) Verify the signal at the receiving device.
  - d) Press **OK**.
  - e) Choose **On**.
  - f) Verify the signal at the receiving device.
  - g) Press **OK**.
  - h) Choose **End**.
3. Test the TPS output.
  - a) Attach a frequency counter, oscilloscope, digital multimeter (DMM), or digital voltmeter (DVM) to the TPS output loop.
  - b) Compare the reading to the Sensor Time Period process variable at your meter.

## Postrequisites

- If the mA Output readings are within 200 microamps of each other, you can correct this discrepancy by trimming the output.
- If the discrepancy between the mA Output readings is greater than 200 microamps, or if at any step the reading was faulty, verify the wiring between the transmitter and the remote device, and try again.
- If the Discrete Output readings are reversed, check the setting of **Discrete Output Polarity**.
- If the TPS output readings do not match, contact customer service.

## 14.7 Status LED states

The status LED on the transmitter indicates whether or not alerts are active. If alerts are active, view the alert list to identify the alerts, then take appropriate action to correct the alert condition.

Your meter has one or two status LEDs:

- A status LED on the display (only if your meter has a display)
- A status LED on the board, beneath the meter housing cover

### CAUTION

If your meter is in a hazardous area, do not remove the meter housing cover. Use a different method to determine meter status.

The status LEDs use colors and flashing to indicate device status.

**Table 14-1: Transmitter status reported by status LED**

LED state	Description	Recommendation
Green	No alerts are active.	Continue with configuration or process measurement.
Yellow	One or more low-severity alerts are active.	A low-severity alert condition does not affect measurement accuracy or output behavior. You can continue with configuration or process measurement. If you choose, you can identify and resolve the alert condition.
Flashing yellow	Calibration in progress, or Known Density Verification in progress.	The low-severity alert condition does not affect measurement accuracy or output behavior. You can continue with configuration or process measurement. If you chose, you can identify and resolve the alert condition.
Red	One or more high-severity alerts are active.	A high-severity alert condition affects measurement accuracy and output behavior. Resolve the alert condition before continuing.

### Related information

[View and acknowledge status alerts](#)

## 14.8 Status alerts, causes, and recommendations

**Table 14-2: Status alerts, causes, and recommendations**

Alert number	Alert title	Possible causes	Recommended actions
A001	EEPROM Error	The transmitter has detected a problem communicating with the sensor.	<ul style="list-style-type: none"> <li>• Cycle power to the meter.</li> <li>• Contact Micro Motion.</li> </ul>



Table 14-2: Status alerts, causes, and recommendations (continued)

Alert number	Alert title	Possible causes	Recommended actions
A002	RAM Error	The transmitter has detected a problem communicating with the sensor.	<ul style="list-style-type: none"> <li>• Cycle power to the meter.</li> <li>• Contact Micro Motion.</li> </ul>
A003	No Sensor Response	The transmitter is not receiving one or more basic electrical signals from the sensor.	<ul style="list-style-type: none"> <li>• Check the drive gain and the pickoff voltage. See <a href="#">Check the drive gain</a> and <a href="#">Check the pickoff voltage</a>.</li> </ul>
A004	Temperature Overrange	The RTD resistance is out of range for the sensor.	<ul style="list-style-type: none"> <li>• Check your process conditions against the values reported by the device.</li> <li>• Verify temperature characterization or calibration parameters.</li> <li>• Contact Micro Motion.</li> </ul>
A006	Characterization Required	Calibration factors have not been entered, or the sensor type is incorrect, or the calibration factors are incorrect for the sensor type.	<ul style="list-style-type: none"> <li>• Verify all of the characterization or calibration parameters. See the sensor tag or the calibration sheet for your meter.</li> <li>• Contact Micro Motion.</li> </ul>
A008	Density Overrange	<p>Applies only to the active calibration.</p> <ul style="list-style-type: none"> <li>• If calibrated for specific gravity or relative density, the overrange is greater than 3.0</li> <li>• If calibrated for molecular weight, the overrange is greater than 86.7 g/mol</li> </ul>	<ul style="list-style-type: none"> <li>• If other alerts are present, resolve those alert conditions first. If the current alert persists, continue with the recommended actions.</li> <li>• Check for foreign material in the process gas or fluid, coating, or other process problems.</li> <li>• Verify all of the characterization or calibration parameters. See the sensor tag or the calibration sheet for your meter.</li> <li>• Check the drive gain and the pickoff voltage. See <a href="#">Check the drive gain</a> and <a href="#">Check the pickoff voltage</a>.</li> <li>• Perform Known Density Verification.</li> <li>• Contact Micro Motion.</li> </ul>
A009	Transmitter Initializing/Warming Up	Transmitter is in power-up mode.	<ul style="list-style-type: none"> <li>• Allow the meter to complete its power-up sequence. The alert should clear automatically.</li> <li>• If other alerts are present, resolve those alert conditions first. If the current alert persists, continue with the recommended actions.</li> <li>• Verify that the transmitter is receiving sufficient power. <ul style="list-style-type: none"> <li>— If it is not, correct the problem and cycle power to the meter.</li> <li>— If it is, this suggests that the transmitter has an internal power issue. Replace the transmitter.</li> </ul> </li> </ul>

**Table 14-2: Status alerts, causes, and recommendations (continued)**

Alert number	Alert title	Possible causes	Recommended actions
A010	Calibration Failure	Many possible causes. This alert will not clear until you correct the problem, acknowledge the alert, and repeat the calibration.	<ul style="list-style-type: none"> <li>Ensure that your calibration procedure meets the documented requirements, cycle power to the meter, then retry the procedure.</li> </ul>
A014	Transmitter Failure	Many possible causes.	<ul style="list-style-type: none"> <li>Ensure that all wiring compartment covers are installed correctly.</li> <li>Ensure that all transmitter wiring meets specifications and that all cable shields are properly terminated.</li> <li>Check the grounding of all components. See <a href="#">Check grounding</a>.</li> <li>Evaluate the environment for sources of high electromagnetic interference (EMI) and relocate the transmitter or wiring as necessary.</li> <li>Contact Micro Motion.</li> </ul>
A016	Sensor Temperature (RTD) Failure	The value computed for the resistance of the line RTD is outside limits.	<ul style="list-style-type: none"> <li>Check your process against the values reported by the device.</li> <li>Contact Micro Motion.</li> </ul>
A020	Calibration Factors Missing	Some calibration factors have not been entered or are incorrect.	<ul style="list-style-type: none"> <li>Verify all of the characterization or calibration parameters. See the sensor tag or the calibration sheet for your meter.</li> <li>Perform site calibration procedures.</li> </ul>
A021	Transmitter/Sensor/Software Mismatch	The configured board type does not match the physical board.	<ul style="list-style-type: none"> <li>Verify all of the characterization or calibration parameters. See the sensor tag or the calibration sheet for your meter.</li> <li>Ensure that the correct board is installed.</li> </ul>
A029	Internal Electronics Failure	This can indicate a loss of communication between the transmitter and the display module.	<ul style="list-style-type: none"> <li>Cycle power to the meter.</li> <li>Replace the display module.</li> <li>Contact Micro Motion.</li> </ul>
A030	Incorrect Board Type	The loaded software is not compatible with the programmed board type.	<ul style="list-style-type: none"> <li>Contact Micro Motion.</li> </ul>
A033	Insufficient Pickoff Signal	The signal from the sensor pickoff(s) is insufficient. This suggests that the sensor tubes or vibrating elements are not vibrating. This alert often occurs in conjunction with Alert 102.	<ul style="list-style-type: none"> <li>Check for foreign material in the process gas or fluid, coating, or other process problems.</li> <li>Check for fluid separation by monitoring the density value and comparing the results against expected density values.</li> <li>Ensure that the sensor orientation is appropriate for your application. Settling from a two-phase or three-phase fluid can cause this alert.</li> </ul>

Table 14-2: Status alerts, causes, and recommendations (continued)

Alert number	Alert title	Possible causes	Recommended actions
A037	Sensor Check Failed	Known Density Verification failed.	<ul style="list-style-type: none"> <li>Check the subtest results and perform the recommended actions.</li> <li>Retry the test.</li> <li>Contact Micro Motion.</li> </ul>
A038	Time Period Signal Out of Range	The time period signal is outside the limits for the sensor type.	<ul style="list-style-type: none"> <li>Check your process conditions against the values reported by the device.</li> </ul>
A100	mA Output 1 Saturated	The calculated mA output value is outside the configured range.	<ul style="list-style-type: none"> <li>Check the settings of <b>Upper Range Value</b> and <b>Lower Range Value</b>. See <a href="#">Check Lower Range Value and Upper Range Value</a>.</li> <li>Check process conditions. Actual conditions may be outside the normal conditions for which the output is configured.</li> <li>Check for foreign material in the process gas or fluid, coating, or other process problems.</li> <li>Verify that the measurement units are configured correctly for your application.</li> </ul>
A101	mA Output 1 Fixed	The HART address is set to a non-zero value, or the mA output is configured to send a constant value.	<ul style="list-style-type: none"> <li>Check whether the output is in loop test mode. If it is, unfix the output.</li> <li>Exit mA output trim, if applicable.</li> <li>Check the HART address. If the HART address is non-zero, you may need to change the setting of <b>mA Output Action (Loop Current Mode)</b>.</li> <li>Check whether the output has been set to a constant value via digital communication.</li> </ul>
A102	Drive Overrange	The drive power (current/voltage) is at its maximum.	<ul style="list-style-type: none"> <li>Check the drive gain and the pickoff voltage. See <a href="#">Check the drive gain</a> and <a href="#">Check the pickoff voltage</a>.</li> <li>Check for foreign material in the process gas or fluid, coating, or other process problems.</li> <li>Check for fluid separation by monitoring the density value and comparing the results against expected density values.</li> <li>Ensure that the sensor orientation is appropriate for your application. Settling from a two-phase or three-phase fluid can cause this alert.</li> </ul>
A104	Calibration in Progress	A calibration procedure is in process.	<ul style="list-style-type: none"> <li>Allow the procedure to complete.</li> </ul>
A106	Burst Mode Enabled	HART burst mode is enabled.	<ul style="list-style-type: none"> <li>No action required.</li> <li>If desired, you can set <b>Alert Severity Level</b> to Ignore.</li> </ul>

**Table 14-2: Status alerts, causes, and recommendations (continued)**

Alert number	Alert title	Possible causes	Recommended actions
A107	Power Reset Occurred	The transmitter has been restarted.	<ul style="list-style-type: none"> <li>No action required.</li> <li>If desired, you can set <b>Alert Severity Level</b> to Ignore.</li> </ul>
A113	mA Output 2 Saturated	The calculated mA output value is outside the configured range.	<ul style="list-style-type: none"> <li>Check the settings of <b>Upper Range Value</b> and <b>Lower Range Value</b>. See <a href="#">Check Lower Range Value and Upper Range Value</a>.</li> <li>Check process conditions. Actual conditions may be outside the normal conditions for which the output is configured.</li> <li>Check for foreign material in the process gas or fluid, coating, or other process problems.</li> <li>Verify that the measurement units are configured correctly for your application.</li> </ul>
A114	mA Output 2 Fixed	The mA output is configured to send a constant value.	<ul style="list-style-type: none"> <li>Check whether the output is in loop test mode. If it is, unfix the output.</li> <li>Exit mA output trim, if applicable.</li> <li>Check whether the output has been set to a constant value via digital communication.</li> </ul>
A115	No External Input or Polled Data	The connection to an external measurement device has failed. No external data is available.	<ul style="list-style-type: none"> <li>Verify that the external device is operating correctly.</li> <li>Verify the wiring between the transmitter and the external device.</li> <li>Verify the HART polling configuration.</li> </ul>
A118	Discrete Output 1 Fixed	The discrete output has been configured to send a constant value.	<ul style="list-style-type: none"> <li>Check whether the output is in loop test mode. If it is, unfix the output.</li> </ul>
A120	Curve Fit Failure (Concentration)	The transmitter was unable to calculate a valid concentration matrix from the current data.	<ul style="list-style-type: none"> <li>Verify the configuration of the concentration measurement application.</li> </ul>
A132	Sensor Simulation Active	Sensor simulation is enabled.	<ul style="list-style-type: none"> <li>Disable sensor simulation.</li> </ul>
A133	EEPROM Error (Display)	There is a memory error in the display module.	<ul style="list-style-type: none"> <li>Cycle power to the meter.</li> <li>Replace the display module.</li> <li>Contact Micro Motion.</li> </ul>
A136	Incorrect Display Type	An incorrect display module has been installed on the device. This may cause a safety violation in hazardous areas.	<ul style="list-style-type: none"> <li>Replace the installed display module with an appropriate display module.</li> </ul>

## 14.9 Primary process variable measurement problems

### 14.9.1 Erratic density reading

#### Alert

Foo.

#### Cause

- Normal process noise
- Line pressure too low
- Condensation or deposition on the vibrating element or the internal walls of the cylinder
- Contaminants or suspended solids in the process gas
- Mechanical vibration in the pipeline
- Leakage from the reference chamber
- Malfunction of the pressure control valve

#### Recommended actions

1. Check your process conditions.
2. Increase the damping value.
3. Reduce the flow rate.
4. Minimize external vibration.
5. Check the coalescing filter. See [Check the coalescing filter](#).
6. Check for leakage. See [Check for leakage](#).
7. Perform Known Density Verification.

### 14.9.2 Inaccurate density reading

#### Cause

- Inaccurate temperature measurement
- Incorrect calibration factors
- Leakage from the reference chamber or into the reference chamber
- Condensation or deposition on the vibrating element or the internal walls of the cylinder
- Contaminants or suspended solids in the process gas

#### Recommended actions

1. Verify the temperature reading from the RTD (on-board temperature sensor).
2. Verify the temperature reading from the external temperature device, if applicable.
3. Check the coalescing filter. See [Check the coalescing filter](#).
4. Increase the flow rate.
5. Install a thermal insulation jacket.

6. Verify the calibration factors.
7. Ensure that the cylinder is positioned correctly.
8. Check for leakage. See [Check for leakage](#).

### 14.9.3 Density reading too high

#### Cause

- Condensation or deposition on the vibrating element or the internal walls of the cylinder
- Leakage from the sample path into the reference chamber
- Corrosion, dents, scratches, or other damage to the cylinder

#### Recommended actions

1. Check the coalescing filter. See [Check the coalescing filter](#).
2. Check for leakage. See [Check for leakage](#).
3. Replace the meter.

### 14.9.4 Density reading too low

#### Cause

- Leakage from the reference chamber to the atmosphere
- Leaks in the pipework or fittings

#### Recommended actions

Check for leakage. See [Check for leakage](#).

## 14.10 Temperature measurement problems

### 14.10.1 Inaccurate temperature data from external device

#### Cause

- Wiring problem
- Problem with input configuration
- Problem with external device

#### Recommended actions

1. Verify the wiring between the transmitter and the external device.
2. Verify that the external device is operating correctly.
3. Verify the configuration of the temperature input.
4. Ensure that both devices are using the same measurement unit.

## 14.11 Gas measurement problems

### 14.11.1 Compressibility or other gas process variable reads NaN (Not a Number)

#### Cause

- Process variable outside valid range for compressibility method
- Input to gas measurement not operational
- Inaccurate density reading due to leakage

#### Recommended actions

1. Ensure that your process is within the valid range for the configured compressibility method.
2. Ensure that all inputs are configured correctly.
3. Ensure that all inputs are operating correctly.
4. Check for leakage.

### 14.11.2 Inaccurate gas readings

#### Cause

- Inaccurate density, temperature, pressure, or other inputs
- Inappropriate calibration factors

#### Recommended actions

1. Ensure that the process data used for gas measurement is accurate. This includes density, temperature, pressure, gas composition.
2. Ensure that the correct calibration is being used for measurement.
3. Recalibrate the device.

## 14.12 Concentration measurement problems

### 14.12.1 Inaccurate concentration measurement reading

#### Cause

- Inaccurate density measurement
- Incorrect matrix data
- Inappropriate trim values

#### Recommended actions

1. Verify the molecular weight, specific gravity, or relative density value. If it is not accurate, resolve your measurement problems.
2. Ensure that the appropriate matrix is active.

3. Ensure that the matrix is configured correctly.
4. Adjust the concentration value by applying an offset. See [Adjust concentration measurement with Trim Offset](#).

## 14.13 Milliamp output problems

**Table 14-3: Milliamp output problems and recommended actions**

Problem	Possible causes	Recommended actions
No mA output	<ul style="list-style-type: none"> <li>• Output not powered</li> <li>• Wiring problem</li> <li>• Circuit failure</li> </ul>	<ul style="list-style-type: none"> <li>• Verify that the output loop is powered externally.</li> <li>• Check the power supply and power supply wiring. See <a href="#">Check power supply wiring</a>.</li> <li>• Verify the output wiring.</li> <li>• Check the <b>Fault Action</b> settings. See <a href="#">Check mA Output Fault Action</a>.</li> <li>• Contact customer service.</li> </ul>
Loop test failed	<ul style="list-style-type: none"> <li>• Output not powered</li> <li>• Power supply problem</li> <li>• Wiring problem</li> <li>• Circuit failure</li> </ul>	<ul style="list-style-type: none"> <li>• Verify that the output loop is powered externally.</li> <li>• Check the power supply and power supply wiring. See <a href="#">Check power supply wiring</a>.</li> <li>• Verify the output wiring.</li> <li>• Check the <b>Fault Action</b> settings. See <a href="#">Check mA Output Fault Action</a>.</li> <li>• Contact customer service.</li> </ul>
mA output below 4 mA	<ul style="list-style-type: none"> <li>• Open in wiring</li> <li>• Bad output circuit</li> <li>• Process condition below LRV</li> <li>• LRV and URV are not set correctly</li> <li>• Fault condition if <b>Fault Action</b> is set to Internal Zero or Downscale</li> <li>• Bad mA receiving device</li> </ul>	<ul style="list-style-type: none"> <li>• Check your process conditions against the values reported by the device.</li> <li>• Verify the receiving device, and the wiring between the transmitter and the receiving device.</li> <li>• Check the settings of <b>Upper Range Value</b> and <b>Lower Range Value</b>. See <a href="#">Check Lower Range Value and Upper Range Value</a>.</li> <li>• Check the <b>Fault Action</b> settings. See <a href="#">Check mA Output Fault Action</a>.</li> </ul>



**Table 14-3: Milliamp output problems and recommended actions (continued)**

Problem	Possible causes	Recommended actions
Constant mA output	<ul style="list-style-type: none"> <li>Incorrect process variable assigned to the output</li> <li>Fault condition exists</li> <li>Non-zero HART address (mA Output 1)</li> <li>Output is configured for loop test mode</li> </ul>	<ul style="list-style-type: none"> <li>Verify the output variable assignments.</li> <li>View and resolve any existing alert conditions.</li> <li>Check the HART address. If the HART address is non-zero, you may need to change the setting of <b>mA Output Action (Loop Current Mode)</b>.</li> <li>Check to see if a loop test is in process (the output is fixed).</li> <li>Check HART burst mode configuration.</li> </ul>
mA output below 3.6 mA or above 21.0 ma	<ul style="list-style-type: none"> <li>Incorrect process variable or units assigned to output</li> <li>Fault condition if <b>Fault Action</b> is set to Upscale or Downscale</li> <li>LRV and URV are not set correctly</li> </ul>	<ul style="list-style-type: none"> <li>Verify the output variable assignments.</li> <li>Verify the measurement units configured for the output.</li> <li>Check the <b>Fault Action</b> settings. See <a href="#">Check mA Output Fault Action</a>.</li> <li>Check the settings of <b>Upper Range Value</b> and <b>Lower Range Value</b>. See <a href="#">Check Lower Range Value and Upper Range Value</a>.</li> <li>Check the mA output trim. See <a href="#">Trim mA outputs</a>.</li> </ul>
Consistently incorrect mA measurement	<ul style="list-style-type: none"> <li>Loop problem</li> <li>Output not trimmed correctly</li> <li>Incorrect measurement unit configured for process variable</li> <li>Incorrect process variable configured</li> <li>LRV and URV are not set correctly</li> </ul>	<ul style="list-style-type: none"> <li>Check the mA output trim. See <a href="#">Trim mA outputs</a>.</li> <li>Verify that the measurement units are configured correctly for your application.</li> <li>Verify the process variable assigned to the mA Output.</li> <li>Check the settings of <b>Upper Range Value</b> and <b>Lower Range Value</b>. See <a href="#">Check Lower Range Value and Upper Range Value</a>.</li> </ul>
mA output correct at lower current, but incorrect at higher current	<ul style="list-style-type: none"> <li>mA loop resistance may be set too high</li> </ul>	<ul style="list-style-type: none"> <li>Verify that the mA Output load resistance is below the maximum supported load (see the installation manual for your transmitter).</li> </ul>

## 14.14 Discrete Output problems

Problem	Possible causes	Recommended actions
No discrete output	<ul style="list-style-type: none"> <li>• Output not powered</li> <li>• Wiring problem</li> <li>• Circuit failure</li> </ul>	<ul style="list-style-type: none"> <li>• Verify that the output loop is powered externally.</li> <li>• Check the power supply and power supply wiring. See <a href="#">Check power supply wiring</a>.</li> <li>• Verify the output wiring.</li> <li>• Contact customer service.</li> </ul>
Loop test failed	<ul style="list-style-type: none"> <li>• Output not powered</li> <li>• Power supply problem</li> <li>• Wiring problem</li> <li>• Circuit failure</li> </ul>	<ul style="list-style-type: none"> <li>• Verify that the output loop is powered externally.</li> <li>• Check the power supply and power supply wiring. See <a href="#">Check power supply wiring</a>.</li> <li>• Verify the output wiring.</li> <li>• Contact customer service.</li> </ul>
Discrete output readings reversed	<ul style="list-style-type: none"> <li>• Wiring problem</li> <li>• Configuration does not match wiring</li> </ul>	<ul style="list-style-type: none"> <li>• Verify the output wiring.</li> <li>• Ensure that <b>Discrete Output Polarity</b> is set correctly.</li> </ul>

## 14.15 Time Period Signal (TPS) output problems

Table 14-4: TPS output problems and recommended actions

Problem	Possible causes	Recommended actions
No TPS output	<ul style="list-style-type: none"> <li>• The TPS output is not supported on this device</li> <li>• TPS wiring is connected to the wrong terminals</li> <li>• Output not powered</li> <li>• External short or low input impedance</li> </ul>	<ul style="list-style-type: none"> <li>• Verify that the output loop is powered externally.</li> <li>• Check the power supply and power supply wiring. See <a href="#">Check power supply wiring</a>.</li> <li>• Verify the output wiring.</li> <li>• Contact customer service.</li> </ul>
Loop test failed	<ul style="list-style-type: none"> <li>• Power supply problem</li> <li>• Wiring problem</li> <li>• Circuit failure</li> </ul>	<ul style="list-style-type: none"> <li>• Verify that the output loop is powered externally.</li> <li>• Check the power supply and power supply wiring. See <a href="#">Check power supply wiring</a>.</li> <li>• Verify the output wiring.</li> <li>• Contact customer service.</li> </ul>

## 14.16 Using sensor simulation for troubleshooting

When sensor simulation is enabled, the transmitter reports user-specified values for basic process variables. This allows you to reproduce various process conditions or to test the system.

You can use sensor simulation to help distinguish between legitimate process noise and externally caused variation. For example, consider a receiving device that reports an unexpectedly erratic specific gravity value. If sensor simulation is enabled and the observed density value does not match the simulated value, the source of the problem is probably somewhere between the transmitter and the receiving device.

---

### Important

When sensor simulation is active, the simulated value is used in all transmitter outputs and calculations. Disable all automatic functions related to the transmitter outputs and place the loop in manual operation. Do not enable simulation mode unless your application can tolerate these effects, and be sure to disable simulation mode when you have finished testing.

---

### Related information

[Test or tune the system using sensor simulation](#)

## 14.17 Trim mA outputs

Trimming an mA output calibrates the transmitter's mA output to the receiving device. If the current trim values are inaccurate, the transmitter will under-compensate or over-compensate the output.

### Related information

[Trim mA Outputs using ProLink III](#)

[Trim mA Outputs using a field communicator](#)

### 14.17.1 Trim mA Outputs using ProLink III

Trimming the mA output establishes a common measurement range between the transmitter and the device that receives the mA Output.

#### Prerequisites

Ensure that the mA Output is wired to the receiving device that will be used in production.

---

#### Important

You must trim the output at both ends (4 mA and 20 mA) to ensure that it is compensated accurately across the entire output range.

---

#### Procedure

1. Choose **Device Tools** → **Calibration** → **MA Output Trim** → **mA Output 1 Trim** or **Device Tools** → **Calibration** → **MA Output Trim** → **mA Output 2 Trim**.
2. Follow the instructions in the guided method.

---

#### Important

If you are using a HART/Bell 202 connection, the HART signal over the primary mA output affects the mA reading. Disconnect the wiring between ProLink III and the transmitter terminals when reading the primary mA Output at the receiving device. Reconnect to continue the trim.

---

3. Check the trim results. If any trim result is less than  $-200$  microamps or greater than  $+200$  microamps, contact customer service.

## 14.17.2 Trim mA Outputs using a field communicator

Trimming the mA Output establishes a common measurement range between the transmitter and the device that receives the mA Output.

### Prerequisites

Ensure that the mA Output is wired to the receiving device that will be used in production.

### Important

You must trim the output at both ends (4 mA and 20 mA) to ensure that it is compensated accurately across the entire output range.

### Procedure

1. Choose **Service Tools** → **Maintenance** → **Routine Maintenance** → **Trim mA Output 1** or **Service Tools** → **Maintenance** → **Routine Maintenance** → **Trim mA Output 2**.
2. Follow the instructions in the guided method.

### Important

The HART signal over the primary mA Output affects the mA reading. Disconnect the wiring between a field communicator and the transmitter terminals when reading the primary mA Output at the receiving device. Reconnect to continue the trim.

3. Check the trim results. If any trim result is less than  $-200$  microamps or greater than  $+200$  microamps, contact customer service.

## 14.18 Check HART communications

If you cannot establish or maintain HART communications, or if the primary mA Output is producing a fixed value, you may have a wiring problem or a HART configuration problem.

### Prerequisites

You may need one or more of the following:

- The installation manual for your meter
- A field communicator
- A voltmeter
- Optional: The *HART Application Guide*, available at [www.hartcomm.org](http://www.hartcomm.org)

### Procedure

1. Verify the HART address.

### Tip

The default HART address is 0. This is the recommended value unless the device is in a multidrop network.

2. If the primary mA Output is producing a fixed value of 4 mA, ensure that **mA Output Action (Loop Current Mode)** is enabled.  
For all HART addresses except 0, **mA Output Action** must be enabled to allow the primary mA output to report process data.
3. Refer to the wiring diagrams in the installation manual and verify that the primary mA Output is correctly wired for HART support.
4. Ensure that the output is powered.
5. Check for electrical problems at the transmitter terminals.
  - a) Disconnect the primary mA Output wires from the transmitter's MAO1 terminals.
  - b) Wire and power the MAO1 terminals as shown in the following figure.

**Figure 14-2: Wiring and power to test terminals**

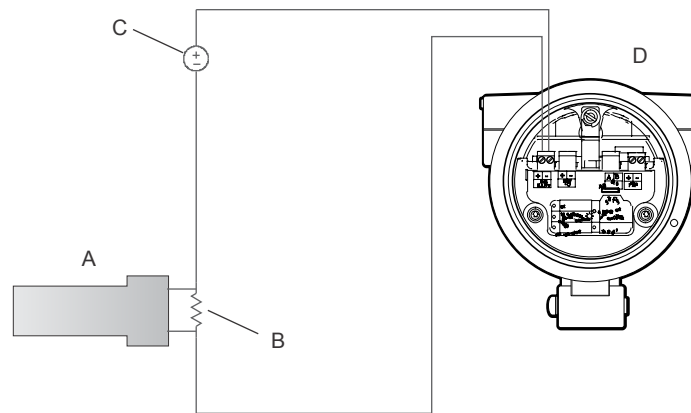

- A. Voltmeter
- B. 250–600  $\Omega$  resistance
- C. External power supply
- D. Transmitter with end-cap removed

- c) Using a voltmeter, check the voltage drop across the resistor.  
For a 250  $\Omega$  resistor, 4–20 mA = 1–5 VDC. If the voltage drop is less than 1 VDC, add resistance to achieve a voltage drop within the required range.
- d) Connect a field communicator directly across the resistor and attempt to communicate (poll).  
If this test fails, the transmitter may need service. Contact Micro Motion.

### Related information

[Configure basic HART parameters](#)

[Using the field communicator with the transmitter](#)

## 14.19 Check Lower Range Value and Upper Range Value

If the process variable assigned to the mA output falls below the configured **Lower Range Value** (LRV) or rises above the configured **Upper Range Value** (URV), the meter will post a saturation alert (A100 or A113), then perform the configured fault action.

### Procedure

1. Record your current process conditions.
2. Check the configuration of the LRV and URV.

### Related information

[Configure Lower Range Value \(LRV\) and Upper Range Value \(URV\)](#)

## 14.20 Check mA Output Fault Action

**mA Output Fault Action** controls the behavior of the mA Output if the transmitter encounters an internal fault condition. If the mA Output is reporting a constant value below 4 mA or above 20 mA, the transmitter may be in a fault condition.

### Procedure

1. Check the status alerts for active fault conditions.
2. If there are active fault conditions, the transmitter is performing correctly. If you want to change its behavior, consider the following options:
  - Change the setting of **mA Output Fault Action**.
  - For the relevant status alerts, change the setting of **Alert Severity** to Ignore.

---

### Restriction

For some status alerts, **Alert Severity** is not configurable.

---

3. If there are no active fault conditions, continue troubleshooting.

## 14.21 Check for radio frequency interference (RFI)

The meter's TPS output or discrete output can be affected by radio frequency interference (RFI). Possible sources of RFI include a source of radio emissions, or a large transformer, pump, or motor that can generate a strong electromagnetic field. Several methods to reduce RFI are available. Use one or more of the following suggestions, as appropriate to your installation.

### Procedure

- Use shielded cable between the output and the receiving device.
  - Terminate the shielding at the receiving device. If this is impossible, terminate the shielding at the cable gland or conduit fitting.
  - Do not terminate the shielding inside the wiring compartment.
  - 360-degree termination of shielding is unnecessary.
- Eliminate the RFI source.

- Move the meter.

## 14.22 Check for leakage

Leakage can cause process problems and inaccurate readings.

---

### Tip

Micro Motion recommends checking for leakage on a regular schedule.

---

### Procedure

1. Check for a leak from the reference chamber to the atmosphere.

This can cause low primary variable readings.

- a) Observe the reference chamber pressure reading. If this leak is present, the reference chamber pressure will be low.
- b) Apply a soap solution around the reference chamber valve and the fitting into the reference chamber.
- c) Watch for bubbles.

If you find a leak, you may be able to plug it. If you cannot resolve the problem, contact customer service.

2. Check for a leaky diaphragm.

The diaphragm can allow leaks from the sample path into the reference chamber. This produces high density readings.

- a) Observe the reference chamber pressure reading. If this leak is present, the reference chamber pressure will increase, and will eventually match line pressure.

Contact customer service.

3. Check for leaks in the pipework or fittings.

Leaks in the pipework or fittings will reduce input pressure. When the input pressure is too low to create flow, the density reading will be low.

- a) Apply a soap solution to all locations where you suspect leaking, including both internal and external pipework.
- b) Watch for bubbles.

If you find a leak, you may be able to plug it. If you cannot resolve the problem, contact customer service.

## 14.23 Check the coalescing filter

For accurate measurement, the coalescing filter must be clean and functional.

### Procedure

- Check the coalescing filter frequently for liquid or particulate contamination, and replace as needed. Frequency of checking depends on the condition of the sample gas.

- Replace the coalescing filter on a regular basis.  
This guards against air or moisture entering the system.

 **CAUTION**

Do not operate the SGM with air in the system. Air in the system, combined with corrosion, can create a source of ignition.

## 14.24 Check the drive gain

Use the following table to check drive gain values. If you see a value that is too high or too low, there could be a problem with the process or with the device. Consider other diagnostics along with drive gain values to determine whether or not you have a problem.

**Table 14-5: Abnormal drive gain, possible causes, and recommended actions**

Drive gain value	Possible causes	Recommended actions
0%	<ul style="list-style-type: none"> <li>• The transmitter is not connected to the sensor.</li> <li>• The connection between the transmitter and the sensor is damaged.</li> </ul>	<ul style="list-style-type: none"> <li>• For integral installations, inspect the connection between the transmitter and the sensor and check for visible problems.</li> <li>• Contact customer service.</li> </ul>
5 to 8%	Normal operation	No action required.
Up to 100%	See <a href="#">Excessive or erratic drive gain</a>	

### 14.24.1 Excessive or erratic drive gain

Excessive or erratic drive gain may indicate any of a variety of process conditions or sensor problems.

To know whether your drive gain is excessive or erratic, you must collect drive gain data during the problem condition and compare it to drive gain data from a period of normal operation.

#### Excessive (saturated) drive gain

**Table 14-6: Possible causes and recommended actions for excessive (saturated) drive gain**

Possible cause	Recommended actions
Deposition on the vibrating element or inner walls of the device	Check for deposition and clean the device if necessary.
Moisture, settling of two-phase or three-phase fluids	<ul style="list-style-type: none"> <li>• Increase the inlet or back pressure at the meter.</li> <li>• If a pump is located upstream from the meter, increase the distance between the pump and meter.</li> <li>• Check for moisture inside the measurement chamber or the reference chamber.</li> </ul>
Drive board or module failure	Contact customer service.
Vibrating element not free to vibrate	Ensure that the vibrating element is free to vibrate.
Open drive coil	Contact customer service.
Incorrect sensor characterization	Verify the characterization or calibration parameters.



## Erratic drive gain

**Table 14-7: Possible causes and recommended actions for erratic drive gain**

Possible cause	Recommended actions
Foreign material caught on vibrating element or in sensor	Ensure that the vibrating element is free to vibrate.

## 14.24.2 Collect drive gain data

Drive gain data can be used to diagnose a variety of process and equipment conditions. Collect drive gain data from a period of normal operation, and use this data as a baseline for troubleshooting.

### Procedure

1. Navigate to the drive gain data.
2. Observe and record drive gain data over an appropriate period of time, under a variety of process conditions.

## 14.25 Check the pickoff voltage

If the pickoff voltage readings are unusually low, you may have any of a variety of process or equipment problems.

Typical pickoff voltage readings go from 0.005 to 0.01 volts.

To know whether your pickoff voltage is unusually low, you must collect pickoff voltage data during the problem condition and compare it to pickoff voltage data from a period of normal operation.

**Table 14-8: Possible causes and recommended actions for low pickoff voltage**

Possible cause	Recommended actions
Moisture, settling of two-phase or three-phase fluids	<ul style="list-style-type: none"> <li>• Increase the inlet or back pressure at the meter.</li> <li>• If a pump is located upstream from the meter, increase the distance between the pump and meter.</li> <li>• Check for moisture inside the measurement chamber or the reference chamber.</li> </ul>
The vibrating element is not vibrating	<ul style="list-style-type: none"> <li>• Check for plugging or deposition.</li> <li>• Ensure that the vibrating element is free to vibrate (no mechanical binding).</li> </ul>
Moisture in the sensor electronics	Eliminate the moisture in the sensor electronics.
The sensor is damaged, or sensor magnets may have become demagnetized	Replace the sensor.

### 14.25.1 Collect pickoff voltage data

Pickoff voltage data can be used to diagnose a variety of process and equipment conditions. Collect pickoff voltage data from a period of normal operation, and use this data as a baseline for troubleshooting.

**Procedure**

1. Navigate to the pickoff voltage data.
2. Observe and record data for both the left pickoff and the right pickoff, over an appropriate period of time, under a variety of process conditions.

## 14.26 Check for internal electrical problems

Shorts between sensor terminals or between the sensor terminals and the sensor case can cause the sensor to stop working.

**Table 14-9: Possible causes and recommended actions for electrical shorts**

Possible cause	Recommended action
Faulty cable	Replace the cable.
Shorts to the housing created by trapped or damaged wires	Contact customer service.
Loose wires or connectors	Contact customer service.
Liquid or moisture inside the housing	Contact customer service.

## 14.27 Locate a device using the HART 7 Squawk feature

The Squawk feature causes the device to show a specific pattern on its display. You can use this to locate or identify a device.

**Restriction**

The Squawk feature is available only with HART 7 connections. It is not available with ProLink III.

**Procedure**

1. Choose **Service Tools** → **Maintenance**.
2. Click **Locate Device**, then click **Next**.

An 0-0-0-0 pattern is shown on the display.

To return to the normal display, activate either **Scroll** or **Select**, or wait 60 seconds.

# A Factory test certificate

## A.1 Sample factory test certificate

Your meter was shipped with a factory test certificate. The certificate describes the testing and configurations that were performed or applied at the factory.

Figure A-1: Sample factory test certificate

	<b>FACTORY TEST CERTIFICATE</b>
<b>SGM GAS SPECIFIC GRAVITY METER</b> SGM4AEABC2B2EBZZ	SERIAL NO : 999999 CAL DATE : 16-Apr-2020 PRESSURE TEST : 20 Bar
	AMPLIFIER NO : 26070565 CYLINDER NO : 9776 CUSTOMER TAGNO : 999999
<b>SPECIFIC GRAVITY CALIBRATION COEFFICIENTS @ 20°C :</b>	<b>SG = K0 + K1*TP + K2*TP²</b>
K0 = CUSTOMER CALIBRATION REQUIRED	CALIBRATION RANGE = CUSTOMER DEFINED
K1 = SEE INSTALLATION MANUAL FOR	NOTE: K2 = 0 FOR TWO POINT CALIBRATIONS
K2 = CALIBRATION PROCEDURE DETAILS	
<b>CYLINDER TEMPERATURE COEFFICIENTS @ 20°C :</b>	
CTC (µs/°C) = 0.000212	
DTC (kg/m³/°C) = 0.000100	
	<b>KNOWN DENSITY VERIFICATION DATA:</b>
	VERIFICATION TIME PERIOD (VACUUM) @ 20°C = 502.3704 µs
where SG = Gas Specific Gravity (uncompensated) TP = Time period (µs) CTC = Cylinder coefficient at 20°C DTC = Cylinder coefficient (Density units) at 20°C	
	<b>FINAL TEST &amp; INSPECTION</b> <b>Passed</b>
Reference V3.0.8.0	

All equipment used for this calibration is calibrated at routine intervals against standards that are traceable to National Standards of Measurement.



## B Using the transmitter display

### B.1 Components of the transmitter interface

The transmitter interface includes the status LED, the display (LCD panel), and two optical switches.

### B.2 Use the optical switches

Use the optical switches on the transmitter interface to control the transmitter display. The transmitter has two optical switches: **Scroll** and **Select**.

#### Procedure

To activate an optical switch, block the light by holding your thumb or finger in front of the opening.

#### Tip

You can activate the optical switch through the lens. Do not remove the transmitter housing cover.

The optical switch indicator lights up when the transmitter senses that an optical switch has been activated.

**Table B-1: Optical switch indicator and optical switch states**

Optical switch indicator	State of optical switches
Solid red	One optical switch is activated.
Flashing red	Both optical switches are activated.

### B.3 Access and use the display menu system

The display menu system is used to perform various configuration, administrative, and maintenance tasks.

#### Prerequisites

To access the display menu system, operator access to either the **Off-Line** menu or the **Alert** menu must be enabled. To access the complete menu system, operator access must be enabled for both the **Off-Line** menu and the **Alert** menu.

#### Tip

The display menu system does not provide complete configuration, administrative, or maintenance functions. For complete transmitter management, you must use another communications tool.

#### Procedure

1. At the transmitter display, activate the **Scroll** and **Select** optical switches simultaneously until the display changes.  
You will enter the **Off-Line** menu at any of several locations, depending on several factors.
  - If an alert is active and access to the **Alert** menu is enabled, you will see **SEE ALARM**.
  - If no alert is active, you will see **OFF-LINE MAINT**.

2. If **CODE?** appears on the display when you make a choice, enter the value that is configured for **Off-Line Password**.
  - a) With the cursor flashing on the first digit, activate **Scroll** until the correct digit is displayed, then activate **Select**.
  - b) Repeat this process for the second, third, and fourth digits.

---

**Tip**

If you do not know the correct value for **Off-Line Password**, wait 30 seconds. The password screen will time out automatically and you will be returned to the previous screen.

---

3. Use the **Scroll** and **Select** optical switches to navigate to your destination in the display menu system.
  - Use **Scroll** to move through a list of options.
  - Use **Select** to choose the current option.
4. If **Scroll** flashes on the display, activate the **Scroll** optical switch, then the **Select** optical switch, and then the **Scroll** optical switch again.

The display will prompt you through this sequence. The **Scroll-Select-Scroll** sequence is designed to guard against accidental activation of the off-line menu. It is not designed as a security measure.
5. To exit a display menu and return to a higher-level menu:
  - Activate **Scroll** until the **EXIT** option is displayed, then activate **Select**.
  - If the **EXIT** option is not available, activate **Scroll** and **Select** simultaneously and hold until the screen returns to the previous display.
6. To exit the display menu system, you can use either of the following methods:
  - Exit each menu separately, working your way back to the top of the menu system.
  - Wait until the display times out and returns to displaying process variable data.

### B.3.1 Enter a floating-point value using the display

Certain configuration values (for example, **Lower Range Value** and **Upper Range Value**) are entered as floating-point values. The display supports both decimal notation and exponential notation for floating-point values.

The display allows you to enter a maximum of 8 characters, including the sign. The decimal point is not counted as a character. Exponential notation is used to enter values that require more than 8 characters.

#### B.3.1 Enter a floating-point value using decimal notation

Decimal notation allows you to enter values between  $-9999999$  and  $99999999$ . You can use the decimal point to enter values with a precision of 0 through 4 (4 characters to the right of the decimal point).

Decimal values entered via the display must meet the following requirements:

- They can contain a maximum of 8 digits, or 7 digits plus a minus sign (-) to indicate a negative number.
- They can contain a decimal point. The decimal point does not count as a digit. The decimal point must be positioned so that the precision of the value does not exceed 4.

When you first enter the configuration screen, the current configuration value is displayed in decimal notation, and the active character is flashing. If the value is positive, no sign is displayed. If the value is negative, a minus sign is displayed.

### Procedure

- To change the value:
  - a) Activate **Select** until the digit you want to change is active (flashing).  
**Select** moves the cursor one position to the left. From the leftmost position, **Select** moves the cursor to the rightmost digit.
  - b) Activate **Scroll** to change the value of the active digit.
  - c) Repeat until all digits are set as desired.
- To change the sign of the value:
  - If the current value is negative, activate **Select** until the minus sign is flashing, then activate **Scroll** until the space is blank.
  - If the current value is positive and there is a blank space at the left of the value, activate **Select** until the cursor is flashing under the blank space, then activate **Scroll** until the minus sign appears.
  - If the current value is positive and there is no blank space at the left of the value, activate **Select** until the cursor is flashing under the leftmost digit, then activate **Scroll** until the minus sign appears.
- To move the decimal point:
  - a) Activate **Select** until the decimal point is flashing.
  - b) Activate **Scroll**.  
The decimal point is removed from its current position.
  - c) Activate **Select** and watch the position of the decimal point.  
As the cursor moves to the left, the decimal point will flash between each pair of digits, up to a maximum precision of four (four digits to the right of the decimal point).

---

**Tip**  
If the position is not valid, the decimal point is not displayed. Continue to activate **Select** until the decimal point appears at the right of the displayed value.

---

  - d) When the decimal point is in the desired position, activate **Scroll**.  
The decimal point is inserted at its current position.
- To save the displayed value to transmitter memory, activate **Scroll** and **Select** simultaneously and hold until the display changes.
  - If the displayed value is the same as the value in transmitter memory, you will be returned to the previous screen.
  - If the displayed value is not the same as the value in transmitter memory, **SAVE/YES?** flashes on the display. Activate **Select**.
- To exit the menu without saving the displayed value to transmitter memory, activate **Scroll** and **Select** simultaneously and hold until the display changes.
  - If the displayed value is the same as the value in transmitter memory, you will be returned to the previous screen.

- If the displayed value is not the same as the value in transmitter memory, **SAVE/YES?** flashes on the display. Activate **Scroll**.

### B.3.1 Enter a floating-point value using exponential notation

Exponential notation is used to enter values that are larger than 99999999 or smaller than -99999999.

Exponential values entered via the display must be in the following form:  $SX.XXXEYY$ . In this string:

- S = Sign. A minus sign (-) indicates a negative number. A blank indicates a positive number.
- X.XXX = The 4-digit mantissa.
- E = The exponent indicator.
- YY = The 2-digit exponent.

#### Procedure

1. Switch from decimal notation to exponential notation.
  - a) Activate **Select** as required until the rightmost digit is flashing.
  - b) Activate **Scroll** until **E** is displayed.
  - c) Activate **Select**.

---

#### Tip

If you have modified the value in decimal notation without saving the changes to transmitter memory, the changes will be lost when you switch to exponential notation. Save the decimal value before switching to exponential notation.

---

2. Enter the exponent.

The first character may be a minus sign or any digit between 0 and 3. The second character may be any digit between 0 and 9.

  - a) Activate **Select** to move the cursor to the rightmost character on the display.
  - b) Activate **Scroll** until the desired character is displayed.
  - c) Activate **Select** to move the cursor one position to the left.
  - d) Activate **Scroll** until the desired character is displayed.
3. Enter the mantissa.

The mantissa must be a 4-digit value with a precision of 3 (that is, all values between 0.000 and 9.999).

  - a) Activate **Select** to move the cursor to the rightmost digit in the mantissa.
  - b) Activate **Scroll** until the desired character is displayed.
  - c) Activate **Select** to move the cursor one digit to the left.
  - d) Activate **Scroll** until the desired character is displayed.
  - e) Activate **Select** to move the cursor one digit to the left.
  - f) Activate **Scroll** until the desired character is displayed.
  - g) Activate **Select** to move the cursor one digit to the left.



- h) Activate **Scroll** until the desired character is displayed.
4. Enter the sign.
- Activate **Select** to move the cursor one digit to the left.
  - Activate **Scroll** until the desired character is displayed.  
For positive numbers, select a blank space.
5. To save the displayed value to transmitter memory, activate **Scroll** and **Select** simultaneously and hold until the display changes.
- If the displayed value is the same as the value in transmitter memory, you will be returned to the previous screen.
  - If the displayed value is not the same as the value in transmitter memory, **SAVE/YES?** flashes on the display. Activate **Select**.
6. Switch back from exponential notation to decimal notation.
- Activate **Select** until the **E** is flashing.
  - Activate **Select** until **d** is displayed.
  - Activate **Select**.

## B.4 Display codes for process variables

Table B-2: Display codes for process variables

Code	Definition
<b>Standard</b>	
DENS	Line Density
TEMP	Sample Temperature
EXT T	Line Temperature (External)
EXT P	Line Pressure (External)
Z	Compressibility
MAG V	Volume Flow Rate (External)
MAG M	Mass Flow Rate (Calculated)
COR M	Mass Flow Rate (External)
COR V	Volume Flow Rate (Calculated)
DRIVE%	Drive Gain
TP B	Sensor Time Period
UCALC	User-Defined Calculation Output
<b>Concentration measurement</b>	
CONC	Concentration
NET M	Net Mass

**Table B-2: Display codes for process variables (continued)**

Code	Definition
NET V	Net Volume
<b>Gas measurement</b>	
BASE/DENS or BDENS	Base Density
SG	Specific Gravity
RD	Relative Density
MW	Molecular Weight
CO2	%CO <sub>2</sub>
N2	%H <sub>2</sub>
H2	%N <sub>2</sub>
CO	%CO
<b>Energy measurement</b>	
CV	Calorific Value
WOBBE	Wobbe Index
ENRGY/FLOW	Energy Flow

## B.5 Codes and abbreviations used in display menus

**Table B-3: Display codes for measurement units**

Code	Measurement unit
%	Percent
%PLATO	°Plato
%SOL-V	% solution by volume
%SOL-W	% solution by weight
%STM Q	% steam quality
°C	°Celsius
°F	°Fahrenheit
°K	°Kelvin
°R	°Rankine
ATM	Atmospheres
B BBL	Beer barrels
BALL	°Balling
BAR	Bars
BAUMH	°Baumé heavy
BAUML	°Baumé light

**Table B-3: Display codes for measurement units (continued)**

<b>Code</b>	<b>Measurement unit</b>
BBBL/D	Beer barrels per day
BBBL/H	Beer barrels per hour
BBBL/M	Beer barrels per minute
BBBL/S	Beer barrels per second
BBL	Barrels
BBL/D	Barrels per day
BBL/H	Barrels per hour
BBL/MN	Barrels per minute
BBL/S	Barrels per second
BTU/D	British Thermal Units per day
BTU/H	British Thermal Units per hour
BTU/lb	British Thermal Units per pound
BTU/MN	British Thermal Units per minute
BTU/scf	British Thermal Units per standard cubic foot
CM	Centimeters
CMHG0	Centimeters of mercury at 4 °C
CMW60	Centimeters of water at 60 °F
cP	Centipoise
cSt	Centistoke
CUF/LB	Cubic feet per pound
CUF/MN	Cubic feet per minute
CUFT	Cubic feet
CUFT/D	Cubic feet per day
CUFT/H	Cubic feet per hour
CUFT/S	Cubic feet per second
CUIN	Cubic inches
CUYD	Cubic yards
D API	°API
DAY	Days
DBRIX	°Brix
DTWAD	°Twaddle
FT	Feet
FT/S	Feet per second

**Table B-3: Display codes for measurement units (continued)**

Code	Measurement unit
FTH20	Feet H2O @ 68 °F
FTW4C	Feet of water at 4 °C
FTW60	Feet of water at 60 °F
G	Grams
G/CM3	Grams per cubic centimeter
G/H	Grams per hour
G/L	Grams per liter
G/MIN	Grams per minute
G/mL	Grams per milliliter
G/MOL	Grams per mole
G/S	Grams per second
G/SCM	Grams per square centimeter
HL	Hectoliters
HOUR	Hours
HPA	Hectopascals
HZ	Hertz
IN	Inches
INH20	Inches of water at 68 °F
INHG	Inches of mercury at 0 °C
INW4C	Inches of water at 4 °C
INW60	Inches of water at 60 °F
KG	Kilograms
KG/D	Kilograms per day
KG/H	Kilograms per hour
KG/L	Kilograms per liter
KG/M2	Kilograms per square meter
KG/M3	Kilograms per cubic meter
KG/MIN	Kilograms per minute
KG/S	Kilograms per second
KG/SCM	Kilograms per square centimeter
KPA	Kilopascals
L	Liters
L/H	Liters per hour

**Table B-3: Display codes for measurement units (continued)**

<b>Code</b>	<b>Measurement unit</b>
L/MIN	Liters per minute
L/S	Liters per second
LB	Pounds
LB/CUF	Pounds per cubic foot
LB/CUI	Pounds per cubic inch
LB/D	Pounds per day
LB/GAL	Pounds per gallon
LB/H	Pounds per hour
LB/MIN	Pounds per minute
LB/S	Pounds per second
LT/D	Long tons per day
LT/H	Long tons per hour
M/H	Meters per hour
M/S	Meters per second
M3	Cubic meters
M3/D	Cubic meters per day
M3/H	Cubic meters per hour
M3/MIN	Cubic meters per minute
M3/S	Cubic meters per second
mA	Milliamperes
mBAR	Millibars
METER	Meters
MHG0C	Meters of mercury at 0 °C
MILG/D	Million gallons per day
MILL/D	Million liters per day
MIN	Minutes
MJ/DAY	Megajoules per day
MJ/H	Megajoules per hour
MJ/kg	Megajoules per kilogram
MJ/m3	Megajoules per cubic meter
MJ/MIN	Megajoules per minute
mm	Millimeters
mmH2O	Millimeters of water at 68 °F

**Table B-3: Display codes for measurement units (continued)**

Code	Measurement unit
mmHG	Millimeters of mercury at 0 °C
mmW4C	Millimeters of water at 4 °C
MPA	Megapascals
mV	Millivolts
MW4C	Meters of water at 4 °C
NL	Normal liters
NL/D	Normal liters per day
NL/H	Normal liters per hour
NL/MIN	Normal liters per minute
NL/S	Normal liters per second
NM3	Normal cubic meters
NM3/D	Normal cubic meters per day
NM3/H	Normal cubic meters per hour
NM3/M	Normal cubic meters per minute
NM3/S	Normal cubic meters per second
OHM	Ohms
OUNCE	Ounce
PA	Pascals
PF	Picofarads
PPM	Parts per million
PRF/M	Proof per mass
PRF/V	Proof per volume
PSF	Pounds per square foot
PSI	Pounds per square inch gauge
PSI A	Pounds per square inch absolute
SCF	Standard cubic feet
SCFD	Standard cubic feet per day
SCFH	Standard cubic feet per hour
SCFM	Standard cubic feet per minute
SCFS	Standard cubic feet per second
SEC	Seconds
SGU	Specific gravity units
SL	Standard liter

**Table B-3: Display codes for measurement units (continued)**

<b>Code</b>	<b>Measurement unit</b>
SL/D	Standard liters per day
SL/H	Standard liters per hour
SL/MIN	Standard liters per minute
SL/S	Standard liters per second
SM3	Standard cubic meter
SM3/D	Standard cubic meters per day
SM3/H	Standard cubic meters per hour
SM3/M	Standard cubic meters per minute
SM3/S	Standard cubic meters per second
SPECL	Special
ST/CUY	Short tons per cubic yard
ST/D	Short tons per day
ST/H	Short tons per hour
ST/MIN	Short tons per minute
T	Metric tons
T/D	Metric tons per day
T/H	Metric tons per hour
T/MIN	Metric tons per minute
TONUK	Long tons (2240 pounds)
TONUS	Short tons (2000 pounds)
TORR	Torr at 0 °C
UKGAL	Imperial gallons
UKGPD	Imperial gallons per day
UKGPH	imperial gallons per hour
UKGPM	Imperial gallons per minute
UKGPS	Imperial gallons per second
UMHO	Microsiemens
uSEC	Microseconds
USGAL	Gallons
USGPD	Gallons per day
USGPH	Gallons per hour
USGPM	Gallons per minute
USGPS	Gallons per second

**Table B-3: Display codes for measurement units (continued)**

Code	Measurement unit
V	Volts

**Table B-4: Display codes for menus, controls, and data**

Code	Definition
12 mA	12 mA value
20 mA	20 mA value
20 mA	20 mA
4 mA	4 mA value
4 mA	4 mA
ABORT	Abort
ACCPT	Accept
ACK	Acknowledge
ACK ALL?	Acknowledge all
ACTIV	Active
ADDR	Address
ALARM	Alert
ALL	All
ALT	Altitude
ANTHR	Another
AO 1	mA Output 1
AO 1 SRC	mA Output 1 Source
AO 2	mA Output 2
AO 2 SRC	mA Output 2 Source
API	API (American Petroleum Institute)
APPLY	Apply
ASCII	ASCII
AUTO	Auto
AUTOSCRL	Auto Scroll
AVG	Average
BASE	Base
BDENS	Base Density
BRD T	Board temperature
CAL	Calibrate or Calibration
CAL	Calibration result



**Table B-4: Display codes for menus, controls, and data (continued)**

<b>Code</b>	<b>Definition</b>
CALC	Calculate
CCAI	Calculated Carbon Aromaticity Index
CH B	Channel B
CHANGE	Change
CHMBR	Chamber
CII	Calculated Ignition Index
CO	Carbon monoxide
CO2	Carbon dioxide
CODE?	Passcode
CONC	Concentration
CONCENTR	Concentration
CONFG	Configure or Configuration
CONFIG	Configure or Configuration
COR M	Mass flow rate from Coriolis input
COR V	Volume flow rate calculated from Coriolis input
CUR Z	Current zero value
CURVE	Matrix
CUSTD	Custody transfer (Weights & Measures)
CUSTODY XFER	Custody transfer (Weights & Measures)
CV	Calorific value
DENS	Density
DEV	Maximum deviation
DGAIN	Drive gain
DISBL	Disabled
DISPLAY	Display
DO	Discrete Output
DO SRC	Discrete Output Source
DRIVE	Drive gain
DRIVE%	Drive gain
DSPLY	Display
DYNV	Dynamic viscosity
ENABL	Enabled
ENGL	English

**Table B-4: Display codes for menus, controls, and data (continued)**

<b>Code</b>	<b>Definition</b>
ENRGY	Energy
ENTER	Enter
ETO	Engineer To Order
EVNT1	Enhanced event 1
EVNT2	Enhanced event 2
EVNT3	Enhanced event 3
EVNT4	Enhanced event 4
EVNT5	Enhanced event 5
EXIT	Exit
EXT P	External or fixed pressure
EXT T	External or fixed temperature
FAC Z	Factory zero value
FACT	Factor
FACTORY	Factory
FAIL	Fail
FAULT	Fault
FCTOR	Factor
FILL	Fill
FIX	Fix
FREN	French
GAS	Gas
GER	German
GOOD	Good
H2	Hydrogen
HART	HART
HIDE	Hide
HIGH	High
IO	Input/Output
K VAL	K value
K0	K0 calibration factor
K1	K1 calibration factor
K2	K2 calibration factor
KDV	Known Density Verification

**Table B-4: Display codes for menus, controls, and data (continued)**

<b>Code</b>	<b>Definition</b>
KINV	Kinematic viscosity
LANG	Language
LANGUAGE	Language
LOADING	Loading
LOW	Low
LPO	Left pickoff
MAG M	Mass flow rate calculated from external volume input
MAG V	Volume flow rate from external input
MAINT	Maintenance
MAO 1	mA Output 1
MAO 2	mA Output 2
MASS	Mass
MBUS	Modbus
MDIUM	Medium
MEASR	Measurement
MMI	Micro Motion
mS	Millisecond
MTR F	Meter factor
MW	Molecular weight
N2	Nitrogen
NET M	Net mass flow rate
NET V	Net volume flow rate
NO	No
nSEC	Nanoseconds
NUMBR	Number
OFF	Off
OFF-LINE	Offline
OFFLN	Offline
OFFSET	Offset
OFFST	Offset
ON	On
O-O-O-O	HART Squawk display
OOR	Out of range

**Table B-4: Display codes for menus, controls, and data (continued)**

<b>Code</b>	<b>Definition</b>
PASS	Password or passcode
PASSW	Password or passcode
POLAR	Polarity
POLARITY	Polarity
POOR	Poor
PoVlt	Pickoff voltage
PTS	Time period signal
Q FCTOR	Quality Factor
RANG	Range
RATE	Scroll Rate or Display Rate
RD	Relative density
RDENS	Referred density
REF	Reference or Referred
RESTORE	Restore
RESULT	Result
RPO	Right pickoff
RTEMP	Reference temperature
RUN	Run
RVISC	Referred viscosity
SAVE	Save
SCALE	Scale
SCL F	Dynamic viscosity scale factor
SCREEN	Screen
SCRLL	Scroll
SCROLL	Scroll
SECURE	Secure mode enabled
SEE	See
SELECT	Select
SET	Set, Set simulated value, Set configuration value
SETPOINT	Setpoint
SG	Specific gravity
SGU	Specific gravity
SHOW	Show

**Table B-4: Display codes for menus, controls, and data (continued)**

<b>Code</b>	<b>Definition</b>
SIM	Simulate, Simulated
SLOPE	Slope
SPAN	Spanish
SRC	Source
SRVIS	Secondary referred viscosity
STAB	Stability
START	Start
STORE	Store
SW	Software
SWREV	Software revision
TCASE	Case temperature
TDIFF	Tube-Case Temperature Difference
TEMP	Temperature
TP	Time Period
TP A	Sensor Time Period (Upper)
TP B	Sensor Time Period
TPS	Time Period Signal
TYPE	Type
UCALC	User-defined calculation
ULTRA	Ultra-low
UNITS	Units
VEL	Velocity
VELSW	Flow switch or velocity switch
VERSION_STRING	Revision or Version
VISC	Viscosity
VOL	Volume
VOLTS	Volts
WOBBE	Wobbe index
XMTR	Transmitter
YES	Yes
YES?	Confirm
Z	Compressibility
ZERO	Zero



# C Using ProLink III with the transmitter

## C.1 Basic information about ProLink III

ProLink III is a configuration and service tool available from Micro Motion. It runs on a Windows platform and provides complete access to transmitter functions and data.

### Version requirements

The following version of ProLink III is required: v3.2 or later.

### ProLink III requirements

To install ProLink III, you must have:

- The ProLink III installation media
- The ProLink III installation kit for your connection type:
  - Converter: RS-232 to RS-485, or RS-232 to Bell 202
  - Cables and connectors: Serial port or USB port

To obtain ProLink III and the appropriate installation kit, contact customer service.

### ProLink III documentation

Most of the instructions in this manual assume that you are already familiar with ProLink III or that you have a general familiarity with Windows programs. If you need more information than this manual provides, see the *Micro Motion ProLink III with ProcessViz Software User Manual*.

In most ProLink III installations, the manual is installed with the ProLink III program. Additionally, the ProLink III manual is available on the documentation CD or at [www.emerson.com](http://www.emerson.com).

### ProLink III features and functions

ProLink III offers complete transmitter configuration and operation functions. ProLink III also offers a number of additional features and functions, including:

- The ability to save the transmitter configuration set to a file on the PC, and reload it or propagate it to other transmitters
- The ability to log specific types of data to a file on the PC
- The ability to view performance trends for various types of data on the PC
- The ability to connect to and view information for more than one device
- A guided connection wizard

These features are documented in the ProLink III manual.

### ProLink III messages

As you use ProLink III with a Micro Motion transmitter, you will see a number of messages and notes. This manual does not document all of these messages and notes.

---

### Important

The user is responsible for responding to messages and notes and complying with all safety messages.

---

## C.2 Connect with ProLink III

A connection from ProLink III to your transmitter allows you to read process data, configure the transmitter, and perform maintenance and troubleshooting tasks.

### C.2.1 Connection types supported by ProLink III

Different connection types are available for connecting from ProLink III to the transmitter. Choose the connection type appropriate to your network and the tasks you intend to perform.

The transmitter supports the following ProLink III connection types:

- Service port connections
- HART/Bell 202 connections
- Modbus/RS-485 8-bit connections (Modbus RTU)
- Modbus/RS-485 7-bit connections (Modbus ASCII)

When selecting a connection type, consider the following:

- Service port connections are specialized Modbus/RS-485 connections that use standard connection parameters and a standard address that are already defined in ProLink III. Service port connections are typically used by field service personnel for specific maintenance and diagnostic functions. Use a service port connection only when another connection type does not provide the functionality you need.
- Some connection types require opening the wiring compartment or the power supply compartment. These connection types should be used only for temporary connections, and may require extra safety precautions.
- Modbus connections, including service port connections, are typically faster than HART connections.
- When you are using a HART connection, ProLink III will not allow you to open more than one window at a time. This is done to manage network traffic and optimize speed.
- You cannot make concurrent Modbus connections if the connections use the same terminals. You can make concurrent Modbus connections if the connections use different terminals.

### C.2.2 Connect with ProLink III over Modbus/RS-485

You can connect directly to the RS-485 terminals on the transmitter or to any point on the network.

#### CAUTION

If the transmitter is in a hazardous area, do not remove the transmitter end-cap while the transmitter is powered up. Removing the end cap while the transmitter is powered up could cause an explosion. To connect to the transmitter in a hazardous environment, use a connection method that does not require removing the transmitter end-cap.

#### Prerequisites

- ProLink III v3.2 or later installed and licensed on your PC
- An available serial port or USB port
- The installation kit appropriate to your connection type (RS-485 or Bell 202, serial port or USB)
- Adapters as required (for example, 9-pin to 25-pin)



## Procedure

1. Attach the signal converter to the serial port or USB port on your PC.
2. To connect directly to the transmitter terminals:
  - a) Remove the transmitter end-cap to access the wiring compartment.
  - b) Connect the leads from the signal converter to the RS-485 terminals.

### Tip

Usually, but not always, you should connect the black lead to the A terminal and the red lead to the B terminal.

**Figure C-1: Connection to RS-485 terminals**

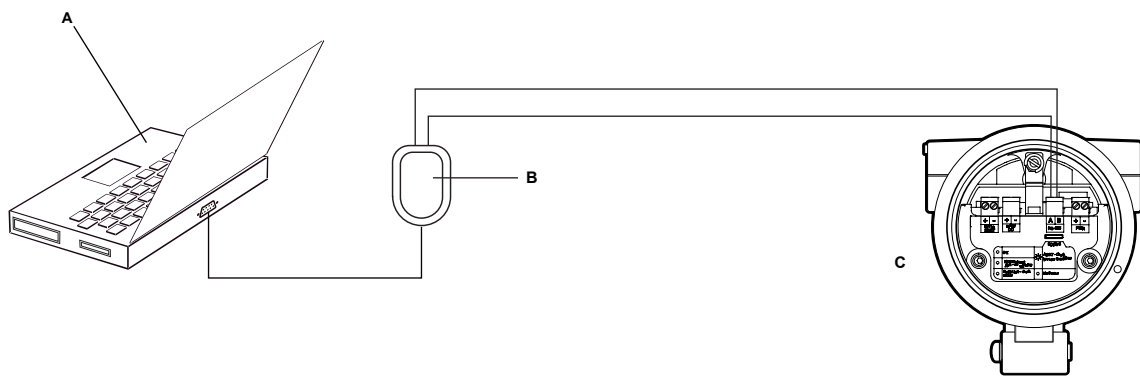

- A. PC
- B. RS-232 to RS-485 converter
- C. Transmitter with end-cap removed

## Note

This figure shows a serial port connection. USB connections are also supported.

3. To connect over the RS-485 network:
  - a) Attach the leads from the signal converter to any point on the network.
  - b) Add resistance as necessary.
  - c) Ensure that the PLC or DCS is not trying to communicate to this meter at this time.

### Restriction

The meter does not support concurrent connections from ProLink III and a PLC or DCS. If another host is already communicating with the meter, ProLink III will not be able to connect, but its connection attempts will corrupt messages from the other host. To make a ProLink III connection, disconnect the cable from the host.

**Figure C-2: Connection over network**

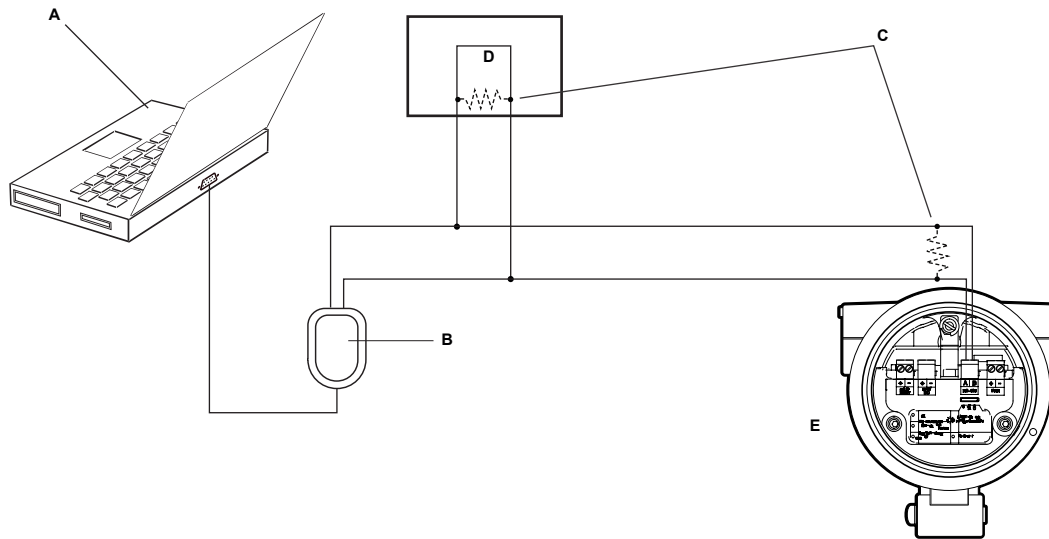

- A. PC
- B. RS-232 to RS-485 converter
- C. 120-Ω, 1/2-watt resistors at both ends of the segment, if necessary
- D. DCS or PLC
- E. Transmitter with end-cap removed

**Note**

This figure shows a serial port connection. USB connections are also supported.

4. Start ProLink III.
5. Choose **Connect to Physical Device**.
6. Set the parameters that are required for your connection type.

**Table C-1: RS-485 connection parameters**

Connection type	Parameter	Value	Optional or required?	Auto-detection
Service port	Protocol	Service Port	Required	No
	PC Port	The PC port that you are using for this connection.	Required	No
Modbus/RS-485	Protocol	Modbus RTU or Modbus ASCII	Required	Yes. The device accepts connection requests that use either protocol, and responds using the same protocol.
	PC Port	The PC port that you are using for this connection.	Required	No
	Address	The Modbus address configured for this transmitter. The default is 1.	Required	No

**Table C-1: RS-485 connection parameters (continued)**

Connection type	Parameter	Value	Optional or required?	Auto-detection
	Baud Rate	1200 to 38400	Optional	Yes. The device accepts connection requests that use any valid setting, and responds using the same setting.
	Parity	None, Odd, Even	Optional	Yes. The device accepts connection requests that use any valid setting, and responds using the same setting.
	Stop Bits	1 or 2	Optional	Yes. The device accepts connection requests that use any valid setting, and responds using the same setting.

7. Click **Connect**.

**Need help?**

If an error message appears:

- Switch the leads and try again.
- Verify the Modbus address of the transmitter.
- Ensure that you have specified the correct port on your PC.
- Check the wiring between the PC and the transmitter.
- For long-distance communication, or if noise from an external source interferes with the signal, install 120-Ω ½-W terminating resistors in parallel with the output at both ends of the communication segment.
- Ensure that there is no concurrent Modbus communication to the transmitter.

## C.2.3 Connect with ProLink III over HART/Bell 202

### Prerequisites

- ProLink III v3.2 or later installed and licensed on your PC
- An available serial port or USB port
- The installation kit appropriate to your connection type (RS-485 or Bell 202, serial port or USB)
- Adapters as required (for example, 9-pin to 25-pin)

You can connect directly to the primary mA terminals on the transmitter, to any point in a local HART loop, or to any point in a HART multidrop network.

**! CAUTION**

If the transmitter is in a hazardous area, do not remove the transmitter end-cap while the transmitter is powered up. Removing the end cap while the transmitter is powered up could cause an explosion. To connect to the transmitter in a hazardous environment, use a connection method that does not require removing the transmitter end-cap.

**! CAUTION**

If you connect directly to the mA terminals, the transmitter's mA Output may be affected. If you are using the mA Output for process control, set devices for manual control before connecting directly to the mA terminals.

**Procedure**

1. Attach the signal converter to the serial port or USB port on your PC.
2. To connect directly to the transmitter terminals:
  - a) Remove the transmitter end-cap to access the wiring compartment.
  - b) Connect the leads from the signal converter to terminals 1 and 2.

---

**Note**

HART connections are not polarity-sensitive. It does not matter which lead you attach to which terminal.

---

- 
- 
- c) Add resistance as necessary to achieve at least one volt across the connection points.

---

**Important**

HART/Bell 202 connections require a voltage drop of 1 VDC. To achieve this, add resistance of 250–600  $\Omega$  to the connection.

---

**Figure C-3: Connection to mA Output terminals**

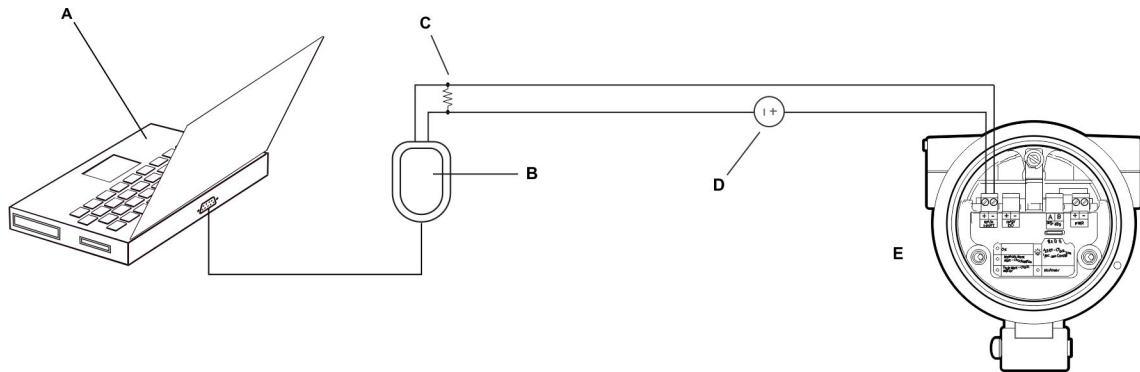

- A. PC
- B. RS-232 to Bell 202 converter
- C. 250–600  $\Omega$  resistance
- D. External power supply
- E. Transmitter with end-cap removed

**Note**

This figure shows a serial port connection. USB connections are also supported.

The signal converter must be connected across a resistance of 250–600  $\Omega$ . The mA Output requires an external power supply with a minimum of 250  $\Omega$  and 17.5 V. See the following figure to help determine the appropriate combination of voltage and resistance. Note that many PLCs have a built-in 250- $\Omega$  resistor. If the PLC is powering the circuit, be sure to take this into consideration.

Figure C-4: Supply voltage and resistance requirements

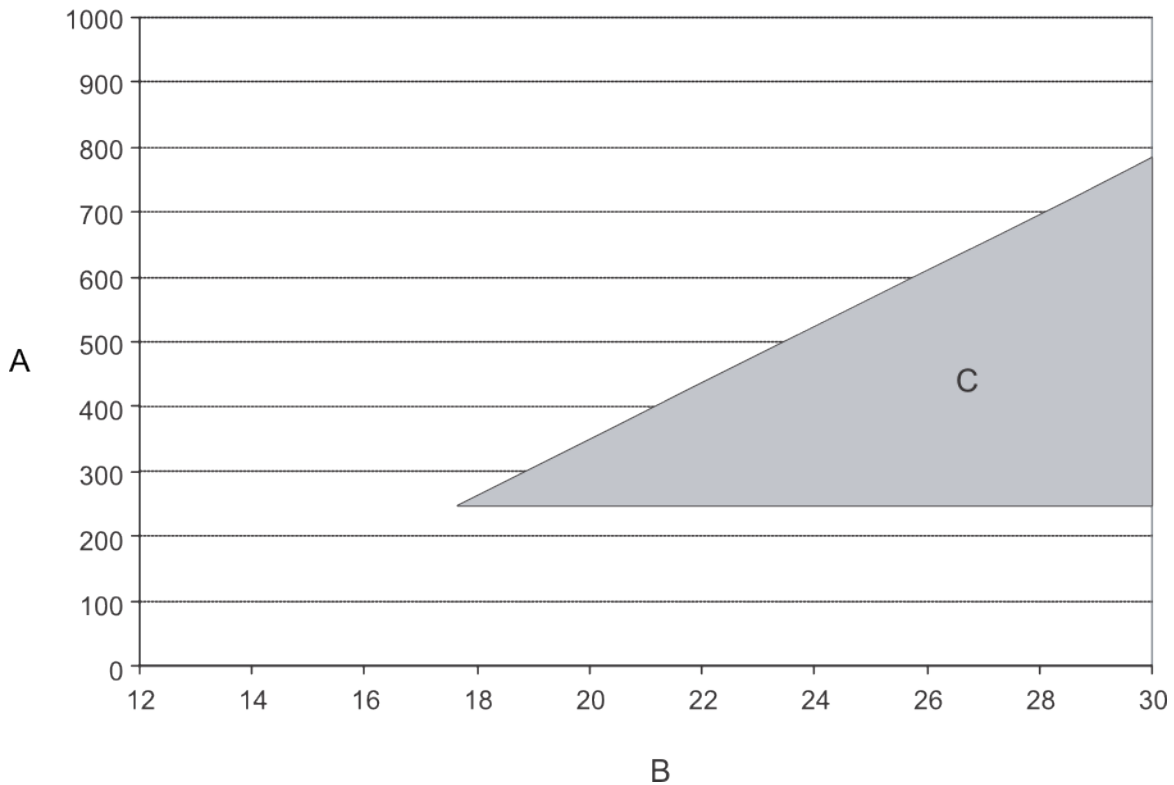

- A. External resistance (ohms)
- B. Supply voltage VDC (volts)
- C. Operating range

**Note**

$$R_{\max} = \frac{(V_{\text{supply}} - 12)}{0.023}$$

3. To connect to a point in the local HART loop:
  - a) Attach the leads from the signal converter to any point in the loop, ensuring that the leads are across the resistor.
  - b) Add resistance as necessary to achieve at least one volt across the connection points.

**Important**

HART/Bell 202 connections require a voltage drop of 1 VDC. To achieve this, add resistance of 250–600 Ω to the connection.

Figure C-5: Connection over local loop

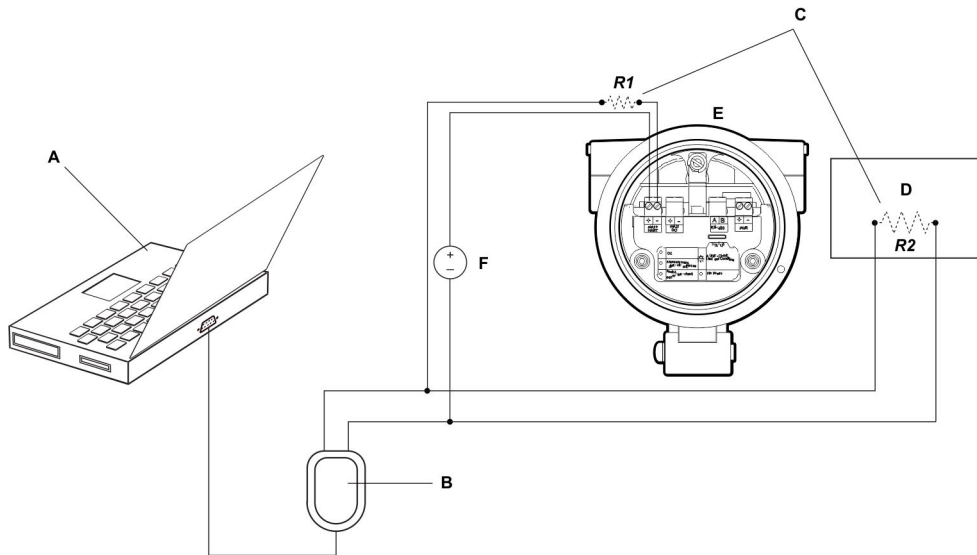

- A. PC
- B. RS-232 to Bell 202 converter
- C. Any combination of resistors  $R1$  and  $R2$  as necessary to meet HART communication resistance requirements
- D. DCS or PLC
- E. Transmitter with end-cap removed
- F. External power supply

**Note**

This figure shows a serial port connection. USB connections are also supported.

The signal converter must be connected across a resistance of 250–600  $\Omega$ . The mA output requires an external power supply with a minimum of 250  $\Omega$  and 17.5 V. See the following figure to help determine the appropriate combination of voltage and resistance. Note that many PLCs have a built-in 250- $\Omega$  resistor. If the PLC is powering the circuit, be sure to take this into consideration.

Figure C-6: Supply voltage and resistance requirements

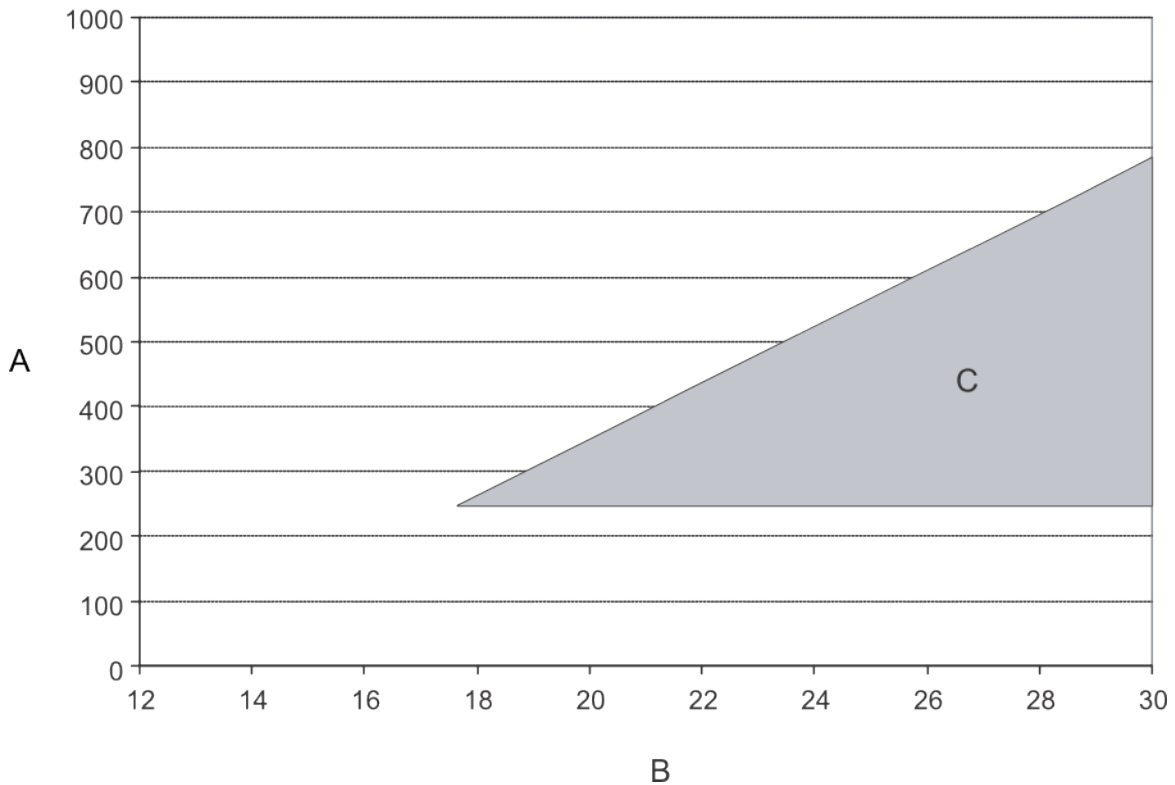

- A. External resistance (ohms)
- B. Supply voltage VDC (volts)
- C. Operating range

**Note**

$$R_{\max} = \frac{(V_{\text{supply}} - 12)}{0.023}$$

- 4. To connect over a HART multidrop network:
  - a) Attach the leads from the signal converter to any point in the loop.
  - b) Add resistance as necessary to achieve at least one volt across the connection points.

**Important**

HART/Bell 202 connections require a voltage drop of 1 VDC. To achieve this, add resistance of 250–600  $\Omega$  to the connection.



**Figure C-7: Connection over multidrop network**

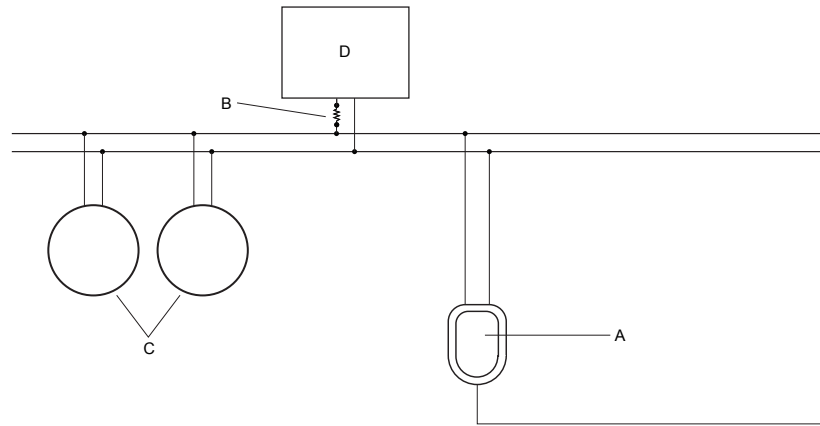

- A. RS-232 to Bell 202 converter
- B. 250–600  $\Omega$  resistance
- C. Devices on the network
- D. Master device

5. Start ProLink III.
6. Choose **Connect to Physical Device**.
7. Set **Protocol** to HART Bell 202.

**Tip**

HART/Bell 202 connections use standard connection parameters. You do not need to configure them here.

8. If you are using a USB signal converter, enable **Toggle RTS**.
9. Set **Address/Tag** to the HART polling address configured in the transmitter.

**Tip**

- If this is the first time you are connecting to the transmitter, use the default address: 0.
- If you are not in a HART multidrop environment, the HART polling address is typically left at the default value.
- If you are unsure of the transmitter’s address, click **Poll**. The program will search the network and return a list of the transmitters that it detects.

10. Set the **PC Port** value to the PC COM port that you are using for this connection.
11. Set **Master** as appropriate.

Option	Description
Secondary	Use this setting if a primary HART host such as a DCS is on the network.
Primary	Use this setting if no other primary host is on the network. A field communicator is a secondary host.

---

12. Click **Connect**.

---

**Need help?**

If an error message appears:

- Verify the HART address of the transmitter, or poll HART addresses 1–15.
  - Ensure that there is at least 1 VDC across the connection terminals. Add resistance as necessary to achieve at least 1 volt.
  - Ensure that you have specified the correct port on your PC.
  - Check the wiring between the PC and the transmitter.
  - Ensure that the mA Output is powered.
  - Increase or decrease resistance.
  - Disable burst mode.
  - Ensure that the resistor is installed correctly. If the mA Output is internally powered (active), the resistor must be installed in parallel. If the mA Output is externally powered (passive), the resistor must be installed in series.
  - Ensure that there is no conflict with another HART master. If any other host (DCS or PLC) is connected to the mA Output, temporarily disconnect the DCS or PLC wiring.
-

# D Using the field communicator with the transmitter

## D.1 Basic information about a field communicator

A field communicator is a hand held configuration and management tool that can be used with a variety of devices, including Micro Motion transmitters. It provides complete access to transmitter functions and data.

### Field communicator documentation

Most of the instructions in this manual assume that you are already familiar with a field communicator and can perform the following tasks:

- Turn on a field communicator
- Navigate the field communicator menus
- Establish communication with HART-compatible devices
- Send configuration data to the device
- Use the alpha keys to enter information

### Device descriptions (DDs)

In order for a field communicator to work with your device, the appropriate device description (DD) must be installed. This meter requires the following HART device description: Density Gas Viscosity Meter Dev v2 DD v1 or later.

To view the device descriptions that are installed on your field communicator:

1. At the HART application menu, press **Utility** → **Available Device Descriptions**.
2. Scroll the list of manufacturers and select **Micro Motion**, then scroll the list of installed device descriptions.

If **Micro Motion** is not listed, or you do not see the required device description, use the Field Communicator Easy Upgrade Utility to install the device description or contact Micro Motion.

### Field communicator menus and messages

Many of the menus in this manual start with the **On-Line** menu. Ensure that you are able to navigate to the **On-Line** menu.

As you use a field communicator with a Micro Motion transmitter, you will see a number of messages and notes. This manual does not document all of these messages and notes.

---

### Important

The user is responsible for responding to messages and notes and complying with all safety messages.

---

## D.2 Connect with a field communicator

A connection from a field communicator to your transmitter allows you to read process data, configure the transmitter, and perform maintenance and troubleshooting tasks.

### Prerequisites

The following HART device description (DD) must be installed on your field communicator: Density Gas Viscosity Meter Dev v2 DD v1 or later.

You can connect a field communicator to the primary mA terminals on the transmitter, to any point in a local HART loop, or to any point in a HART multidrop network.



### CAUTION

If the transmitter is in a hazardous area, do not connect your field communicator to the mA terminals on the transmitter. This connection requires opening the wiring compartment, and opening the wiring compartment in a hazardous area can cause an explosion.

---

### Important

If the HART security switch is set to **ON**, HART protocol cannot be used to perform any action that requires writing to the transmitter. For example, you cannot change the configuration, reset totalizers, or perform calibration using a field communicator. When the HART security switch is set to **OFF**, no functions are disabled.

---

### Procedure

1. To connect to the transmitter terminals:
  - a) Remove the transmitter end-cap.
  - b) Attach the leads from your field communicator to terminals 1 and 2 on the transmitter and add resistance as required.

Your field communicator must be connected across a resistance of 250–600  $\Omega$ .

---

### Tip

HART connections are not polarity-sensitive. It does not matter which lead you attach to which terminal.

---

**Figure D-1: Field communicator connection to transmitter terminals**

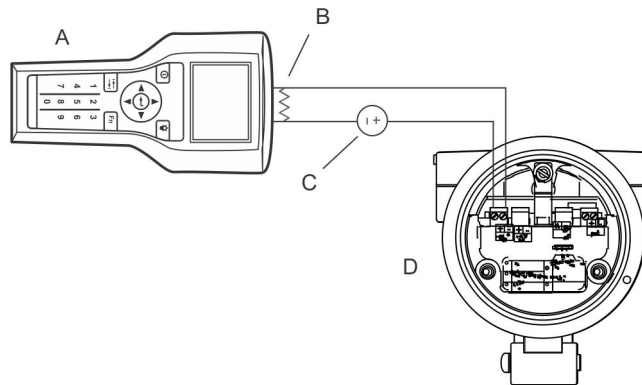

- A. Field communicator
- B. 250–600  $\Omega$  resistance
- C. External power supply
- D. Transmitter with end-cap removed

2. To connect to a point in the local HART loop, attach the leads from your field communicator to any point in the loop and add resistance as necessary.  
Your field communicator must be connected across a resistance of 250–600  $\Omega$ .

**Figure D-2: Field communicator connection to local HART loop**

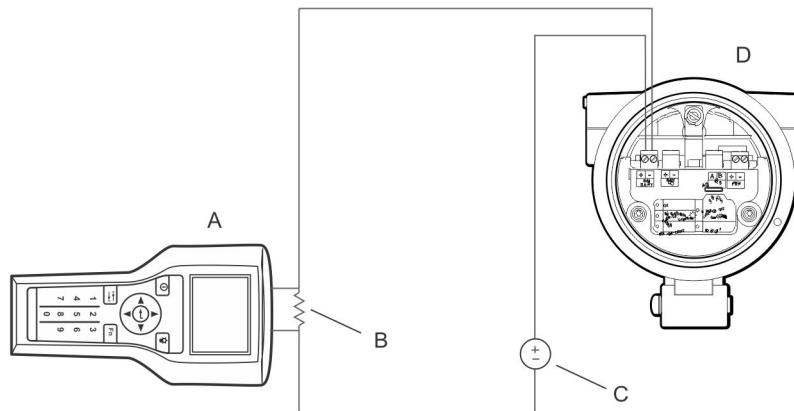

- A. Field communicator
- B. 250–600  $\Omega$  resistance
- C. External power supply
- D. Transmitter with end-cap removed

3. To connect to a point in the HART multidrop network, attach the leads from your field communicator to any point on the network.

Figure D-3: Field communicator connection to multidrop network

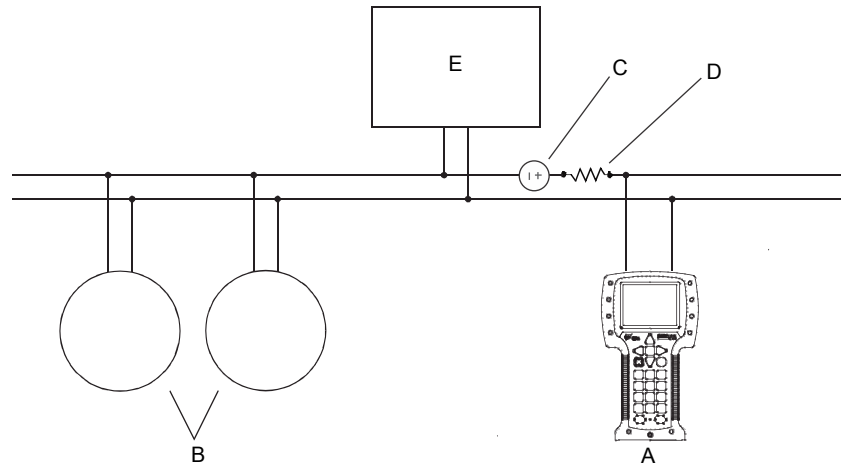

- A. Field communicator
- B. Devices on the network
- C. External power supply (may be provided by the PLC)
- D. 250–600  $\Omega$  resistance (may be provided by the PLC)
- E. Master device

4. Turn on your field communicator and wait until the main menu is displayed.
5. If you are connecting across a multidrop network:
  - Set the field communicator to poll. The device returns all valid addresses.
  - Enter the HART address of the transmitter. The default HART address is 0. However, in a multidrop network, the HART address has probably been set to a different, unique value.

### Postrequisites

To navigate to the **Online** menu, choose **HART Application** → **Online**. Most configuration, maintenance, and troubleshooting tasks are performed from the **Online** menu.

### Tip

You may see messages related to the DD or active alerts. Press the appropriate buttons to ignore the message and continue.

### Need help?

A field communicator requires a minimum of 1 VDC across the connection leads to communicate. If necessary, increase the resistance at the connection point until 1 VDC is achieved.

## E Three-point calibration

Use ProLink III to run a three-point calibration.

For general applications like specific gravity, molecular weight, relative density, or energy content, the two-point calibration is the standard procedure to achieve the specified performance.

For specialty applications like purity determination or H<sub>2</sub> blending, the three-point calibration is recommended to maintain the required resolution and linearity.

---

### Note

A three-point calibration produces three calibration factors: K0, K1, and K2.

---

### Prerequisites

SGM calibration is required to generate calibration coefficients for your process gas. These coefficients are required for accurate measurement.

- Complete the purge procedure. The reference chamber must be filled with the reference gas to the appropriate pressure.
- Know whether you want the device to operate as a specific gravity meter, a molecular weight meter, or a relative density meter.
- Identify all required calibration gases and know their specific gravity, molecular weight, or relative density.
- Prepare to flow all calibration gases through the device at the appropriate sample pressure. In a typical application, the sample pressure should be approximately 15% to 25% greater than the reference chamber pressure.
- Use the following diagram as a reference.

Figure E-1: Typical SGM installation

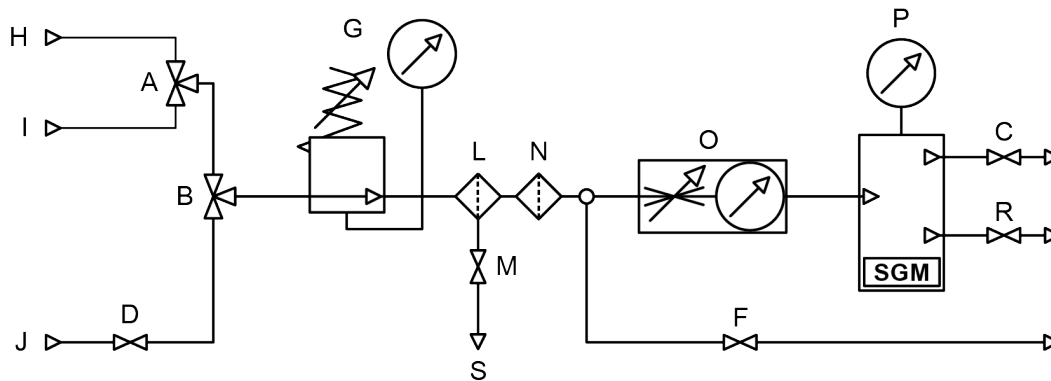

- A. Calibration gas selector three-way valve
- B. Process/Calibration gas selector three-way valve
- C. Outlet two-way valve
- D. Process gas inlet two-way valve
- E. Chamber fill valve
- F. Purge two-way valve
- G. Pressure regulator with gauge
- H. Calibration gas 1 inlet
- I. Calibration gas 2 inlet
- J. Process gas sampling point
- K. Tubing work (not shown in diagram)
- L. Coalescent filter
- M. Coalescent filter drain two-way valve
- N. Particle filter
- O. Flow meter
- P. Transmitter
- Q. Reference chamber pressure indicator
- R. Relief valve
- S. Drain

**Procedure**

1. Choose **Device Tools** → **Calibration** → **Gas Calibration**.
2. Set the measurement type for this device.

Option	Description
Specific Gravity (SG)	Gas density will be measured as specific gravity, and specific gravity will be used for calibration.
Molecular Weight (MW)	Gas density will be measured as molecular weight, and molecular weight will be used for calibration.
Relative Density (RD)	Gas density will be measured as relative density, and relative density will be used for calibration.



3. Select **Next**.
4. Set the calibration type (calibration format) as 3-Point Calibration (3 PT).  
Three-point calibration is appropriate only if recommended by customer support.
5. Select **Next**.
6. Select the calibration number you want to perform.  
The device can store up to four independent calibrations or calibration ranges. All calibrations must have the same calibration type (2-point or 3-point). Each calibration can use different calibration gases.
7. Enter data for each calibration gas.
  - a) Select the calibration gas from the list. If it is not listed, select **Other**.
  - b) Enter the specific gravity, molecular weight, or relative density of the calibration gas.
  - c) Select **Next**.

---

**Tip**

Enter the calibration gases in order of density, from lowest to highest. This order allows heavier gases to replace lighter gases.

---

8. Set the low density calibration point.
  - a) Connect the lower **Calibration Gas** to the calibration gas inlet 1.
  - b) Set the pressure regulator on the lower calibration gas tank to the appropriate sample pressure for your installation.

---

**Important**

Make sure the process gas inlet two-way valve (D) is closed.

---

- c) Set the process/calibration gas valve to the calibration position.
  - d) Set the calibration gas selector valve to the calibration gas inlet 1 position, and open the outlet valve.
  - e) As the gas flows, select the **Start** button and observe the **Live Sensor Time Period** and **Stability** values.
  - f) Wait between 3 to 15 minutes for the system to stabilize.
  - g) When **Stability** is **Good**, select **Accept**.  
If measurement does not stabilize after 30 minutes, select **Abort** and troubleshoot the problem.
  - h) Disconnect the calibration gas.
9. Set the mid-range calibration point.
  - a) Connect the mid-range **Calibration Gas** to the pipework. Use calibration gas inlet 1.
  - b) Set the pressure regulator on the mid-range calibration gas tank to the appropriate sample pressure for your installation.

---

**Important**

Make sure the process gas inlet two-way valve (D) is closed and the calibration gas selector valve remains set to the calibration gas 1 position with the outlet valve open.

---

- c) As the gas flows, observe the **Sensor Time Period** and **Stability** values.
  - d) Wait between 3 to 15 minutes for the system to stabilize.
  - e) When **Stability** is **Good**, select **Accept**.  
If measurement does not stabilize after 30 minutes, select **Abort** and troubleshoot the problem.
  - f) Disconnect the calibration gas.
10. Set the high density calibration point.
- a) Connect the higher **Calibration Gas** to the calibration gas inlet 2.
  - b) Set the pressure regulator on the higher calibration gas tank to the appropriate sample pressure for your installation.
  - c) Set the process/calibration gas valve to the calibration position.
  - d) Set the calibration gas selector valve to the calibration gas inlet 2 position, and keep the outlet valve open.
  - e) As the gas flows, select the **Start** button and observe the **Sensor Time Period** and **Stability** values.
  - f) Wait between 3 to 15 minutes for the system to stabilize.
  - g) When **Stability** is **Good**, select **Accept**.  
If measurement does not stabilize after 30 minutes, select **Abort** and troubleshoot the problem.
  - h) Disconnect the calibration gas.
11. Select **Next**.
12. Review the results for this calibration.
13. Select **Finish** to save the results and exit, or select **Add Calibration** to add a calibration.

---

**Tip**

You can also set **Active Calibration** from the **Calibration Data** window. This allows you to change the calibration without going through the calibration wizard.

---

For three-point calibrations, three calibration coefficients (K0, K1, and K2) are calculated and used in measurement.

14. Finish the calibration by doing the following steps:
- a) Shut off the calibration gas regulators.
  - b) Set the process/calibration selector valve to the process gas position.
  - c) Open the process gas inlet valve to let process gas flow through the system to be measured.

The SGM is ready to be used.

**Related information**

[Calibrate the SGM device](#)

## F Calculate measurement errors using reference chamber pressure

For evaluation purposes, you can use this procedure to determine the expected accuracy using the reference chamber pressure. However, for most common applications, the accuracy will perform within 0.1% of reading.

Your selection of control reference chamber pressure determines the range of possible measurement errors. You can calculate the measurement error associated with different control reference chamber pressures and use this procedure to determine the control reference chamber pressure.

Use this procedure to calculate the measurement error associated with several different reference chamber pressures.

### Procedure

1. Print out the appropriate calculation aid in [Calculation aid and examples](#).
2. Record your process gas and the expected specific gravity range.
3. Record the Density Temperature Coefficient (DTC) for the meter.  
The DTC is provided on the meter's calibration sheet and on a label inside the transmitter front cover.
4. Check the example references chamber pressures on the calculation aid and change them as needed.
5. Using the following equations, calculate the density range for each reference chamber pressure.

---

#### Figure F-1: Density range (minimum and maximum)

$$SG_{min} = P \times \rho_{Air} \times SG_{min}$$

$$SG_{max} = P \times \rho_{Air} \times SG_{max}$$

<b>P</b>	Reference chamber pressure (bara)
<b><math>\rho_{Air}</math></b>	Density of clean dry air (1.2 kg/m <sup>3</sup> approximately)
<b><math>SG_{min}</math></b>	Specific gravity minimum value
<b><math>SG_{max}</math></b>	Specific gravity maximum value

---

6. Using the following equations, calculate the measurement error for each density range.

---

#### Figure F-2: Temperature coefficient error

$$Error_{DTC} = \frac{DTC}{\rho_{max}} \times 100\% / ^\circ C$$

<b>DTC</b>	Temperature coefficient for this meter
<b><math>\rho_{max}</math></b>	Maximum density value (kg/m <sup>3</sup> )

---

**Figure F-3: Gas compressibility error**

$$Error_Z = \pm 0.67 \times T(CC_{GasRef} - TCC_{GasSample})$$

**TCC<sub>GasRef</sub>** For the reference gas, the coefficient that describes the relationship between temperature and compressibility at reference chamber pressure. Refer to the international gas standard tables, such as ISO12213 if required.

**TCC<sub>GasSample</sub>** For the sample gas, the coefficient that describes the relationship between temperature and compressibility at reference chamber pressure. Refer to the international standard gas tables, such as ISO12213 if required.

**Figure F-4: Velocity of sound error**

$$Error_{VOS} = - 0.0034 \times SG_{Max}\% / ^\circ C$$

**SG<sub>max</sub>** Maximum specific gravity value

## F.1 Calculation aid and examples

### Blank calculation form

Type of gas:		Specific gravity range: _____ to _____			
<b>SGM temp coefficient (kg/m<sup>3</sup>/°C):</b>					
Reference chamber pressure at 20 °C:		18 psia (1.24 bara)	30 psia (2 bara)	60 psia (4 bara)	100 psia (7 bara)
Density range at 20 °C: in kg/m <sup>3</sup> :		_____ to _____	_____ to _____	_____ to _____	_____ to _____
Measurement error <sup>(1)</sup>	Temp coefficient error:				
	Gas compressibility of sample gas:				
	Velocity of sound in sample gas:				
	Reference chamber or relief valve:				
Total error (%):					

(1) % of full-scale specific gravity / C

**Example: Calculating the control reference chamber pressure for natural gas**

Type of gas: Natural gas		Specific gravity range: 0.55 to 0.8			
SGM temp coefficient (kg/m <sup>3</sup> /°C): -0.0003					
Reference chamber pressure at 20 °C:		18 psia (1.24 bara)	30 psia (2 bara)	60 psia (4 bara)	100 psia (7 bara)
Density range at 20 °C: in kg/m <sup>3</sup> :		0.79 to 1.15	1.32 to 1.92	2.64 to 3.84	4.62 to 6.72
Measurement error <sup>(1)</sup>	Temp coefficient error:	-0.026	-0.016	-0.008	-0.004
	Gas compressibility of sample gas:	±0.0003	±0.0003	±0.001	±0.002
	Velocity of sound in sample gas:	-0.003	-0.003	-0.003	-0.003
	Reference chamber or relief valve:	+0.007	+0.007	+0.007	+0.007
Total error (%):		-0.022	-0.012	-0.005 to +0.003	-0.002 to 0.000

(1) % of full-scale specific gravity / C

**Example: Calculating the control reference chamber pressure for an N<sub>2</sub>/CO<sub>2</sub> mix**

Type of gas: N <sub>2</sub> /CO <sub>2</sub> mix		Specific gravity range: 1.0 to 1.5			
SGM temp coefficient (kg/m <sup>3</sup> /°C): -0.0003					
Reference chamber pressure at 20 °C:		18 psia (1.24 bara)	30 psia (2 bara)	60 psia (4 bara)	100 psia (7 bara)
Density range at 20 °C: in kg/m <sup>3</sup> :		1.44 to 2.16	2.4 to 3.6	4.8 to 7.2	8.4 to 12.6
Measurement error <sup>(1)</sup>	Temp coefficient error:	-0.014	-0.008	-0.004	-0.002
	Gas compressibility of sample gas:	±0.002	±0.004	±0.008	±0.015
	Velocity of sound in sample gas:	-0.005	-0.005	-0.005	-0.005
	Reference chamber or relief valve:	+0.007	+0.007	+0.007	+0.007
Total error (%):		-0.014	-0.006	-0.010 to +0.006	-0.015 to +0.015

(1) % of full-scale specific gravity / C



MMI-20020954  
Rev. AE  
2021

For more information: [www.emerson.com](http://www.emerson.com)

©2021 Micro Motion, Inc. All rights reserved.

The Emerson logo is a trademark and service mark of Emerson Electric Co. Micro Motion, ELITE, ProLink, MVD and MVD Direct Connect marks are marks of one of the Emerson Automation Solutions family of companies. All other marks are property of their respective owners.

**MICRO MOTION™**

