

# Shafer ECAT

Emission Controlled Actuation Technology

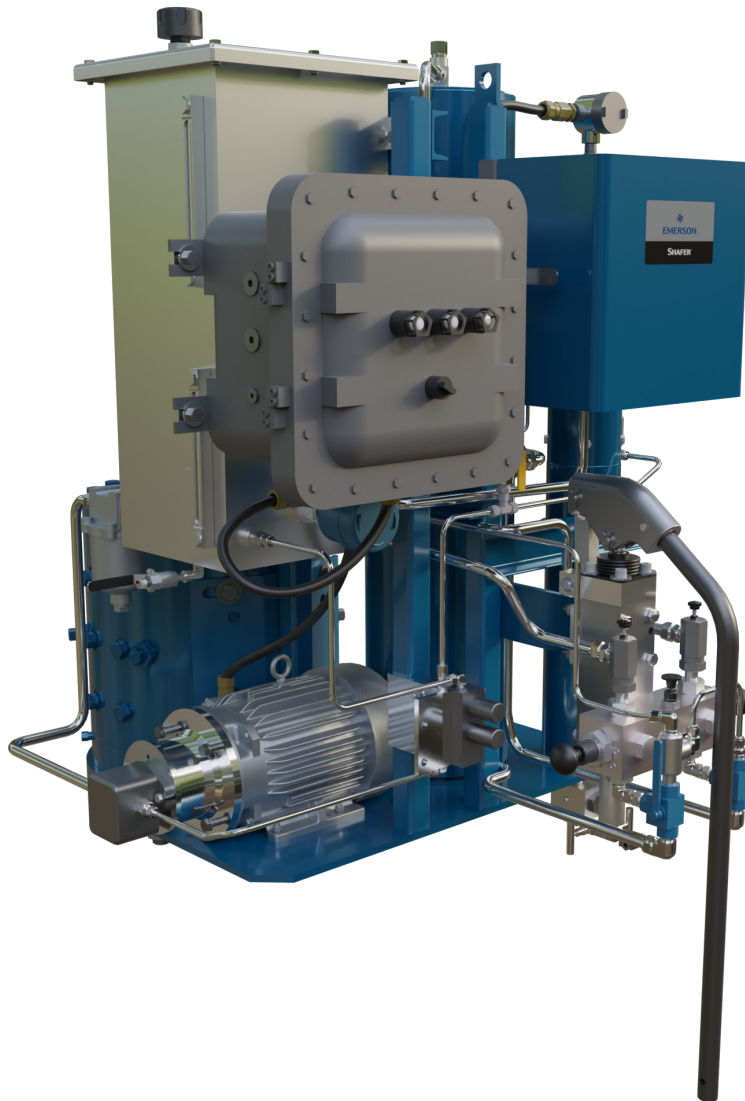

*This page is intentionally left blank.*

# Table of Contents

## Section 1: Introduction

1.1	Scope .....	1
1.2	General Information .....	1
1.3	Safety Information.....	3
1.4	Abbreviation Definitions.....	4

## Section 2: Installation

2.1	Preparation .....	5
2.2	Valve Preparation.....	6
2.3	Actuator Preparation .....	6
2.4	Lifting the ECAT System.....	7
2.5	Installing the ECAT System on the Valve.....	9
2.6	Setting the Stroke Limit Stops .....	9
2.7	Hydraulic Fluid.....	10
2.8	Accumulator.....	10

## Section 3: Electrical Connections

3.1	Main Electrical Connections .....	15
3.2	Sealing Cable/Conduit Entries .....	15

## Section 4: Set-up/Start-up Procedure

4.1	Preparation .....	16
4.2	Initial Check of the Unit.....	17
4.3	Initial Connections.....	17
4.4	Initial Pre-Charge.....	17
4.5	Initial Reservoir Fill.....	17
4.6	Hydrostatic Pressure/Function Test.....	17
4.7	Final Start-up Procedure .....	19
4.8	Level Switch Testing .....	19
4.9	Optional Instrumentation.....	19
4.10	Local Hand Pump (To Open or Close the Actuator).....	19
4.11	Shafer Speed Control Setup.....	21
4.12	ECAT Pump Discharge Manifold Assembly .....	22

## Section 5: Troubleshooting

Troubleshooting.....	23
----------------------	----

## Section 6: Maintenance

6.1	Storage Procedures .....	24
6.2	Service Interval.....	24
6.3	Lubrication Requirements .....	24
6.4	Maintenance Instructions.....	25
6.5	Recommended Annual Inspection .....	30

*This page is intentionally left blank.*

# Section 1: Introduction

## 1.1 Scope

This manual is offered as a guide to be used along with locally approved and safe practices to install, operate, service and maintain the ECAT system. Carefully follow the instructions in this manual and make sure you install the system correctly and according to your requirements.

## 1.2 General Information

### 1.2.1 Overview

The Emissions Controlled Actuation Technology (ECAT) is a self-contained, quarter-turn valve operating system that combines proven technologies from Emerson's valve automation portfolio. The system has been designed for critical shutdown applications where reliability is crucial.

The ECAT utilizes a hydraulic accumulator, pressurized with pipeline gas, as a stored energy source in order to actuate the actuator/valve to an open or closed position. The self-contained system includes an electric motor, gear pump, suction strainer and reservoir. Pressure switches for alarming and return line hydraulic filtration are available as an option.

### 1.2.2 Operation

After initial start-up and commissioning procedures have been accomplished, the electric driven hydraulic pump will keep the power header and all accumulators pressurized to the appropriate pressure with no intervention from operations personnel.

### 1.2.3 Maintaining Pressure

Any loss of pressure in the power header line or accumulators, whether caused by external leakage or actuator movement, will cause the thermal-volume controller rod to move down. This movement operates the motor control switch to the "Motor On" position, automatically starting the electric driven hydraulic pump. The pump will run until the hydraulic fluid in the power header line and all accumulators has been replenished. When the header and accumulator have been filled, the thermal-volume controller rod will rise and operate the motor control switch to the "Motor Off" position. There is no need for the pump to be started or stopped by operations personnel.

### 1.2.4 Mechanically Operated Components

The only mechanically operated component on the ECAT system is the motor control switch located on the thermal volume controller. This switch detects the position of the thermal-volume controller and relays the information back to the control. The control then starts or stops a motor as needed. The switch does not require adjustment or maintenance.

### 1.2.5 Relieving Pressure on the Fluid

High-pressure hydraulic fluid can be safely routed back to the reservoir from the accumulator or actuator units by opening the main accumulator Bypass valve located on the reservoir. Opening this valve will allow the pressurized fluid in the system to be common to the reservoir. This valve should be opened slowly to prevent the high-pressure fluid from foaming due to the velocity through the hand valve. A hydraulic thermal relief valve is piped in parallel to this hand valve for the purpose of relieving excess hydraulic pressure in case the control malfunctions or ambient temperature conditions exceed design limits.

### 1.2.6 Fluid Level in Reservoir

The reservoir tank is provided with a stainless steel sight glass level viewer.

### 1.2.7 Functional Description

The following is a functional description of the ECAT system for valve actuators and a brief explanation of the main components that make this ECAT system unique. Throughout this explanation numbers which appear in parenthesis ( ) correspond to item numbers on Schematic Diagram 12308-S.

The ECAT system provides energy for operation of valve actuators during normal operation as well as emergency shutdown. This energy is hydraulic power stored in the Accumulator (76). When required, the Accumulator (76) pushes the hydraulic fluid into the power oil header line. The power oil header line supplies the actuator power for operation.

The hydraulic fluid leaving the valve actuator will pass through the return oil header line back into the Oil Reservoir (60) creating a closed loop system.

The Accumulator (76) gets its power from high-pressure pipeline gas pushing on the accumulator's piston.

The hydraulic fluid, stored in the Accumulator (76), originates from the Oil Reservoir (60). Fluid is drawn from the Oil Reservoir (60) and through the suction line by a Hydraulic Pump (67). The hydraulic pump (67) forces the fluid through the discharge line and into the Accumulator (76).

The ECAT system has one electric motor driven Hydraulic Pump (67). The pump is controlled by a motor control switch operated by the Thermal-Volume Controller (77). While in operation, if the Thermal-Volume Controller (77) moves a small amount actuating the Motor Start/Stop Switch (78) to the "On" position, the electric motor driven Hydraulic Pump (67) will start to run. The pump will operate until the Thermal-Volume Controller moves and actuates the Motor Start/Stop Switch (78) to the "Off" position.

### 1.2.8 Product Attributes

- Easy installation – ECAT is a totally self-contained system and designed for compactness and adaptable to new or existing valves
- Designed for Bettis™ or Shafer™ hydraulic double-acting actuator and controls, including the hand pump; may be purchased as an upgrade for most existing installations
- Shafer hydraulic control technology
- Multiple input power options with either AC or DC
- Local open/close control
- Fast speed of operation to fail-safe position if required
- Accumulator suitable for hydraulic and natural gas service
- Operating pressures up to 2220 psi with standard components

## 1.3 Safety Information

Safety notices in this manual detail precautions the user must take to reduce the risk of personal injury and damage to the equipment. The user must read these instructions in their entirety. Failure to observe these safety notices could result in serious bodily injury, damage to the equipment, void of the warranty. Take special notice of all tags, warning labels and instructions presented on the actuator. These may provide more specific and significant information regarding the actuator than this general manual.

It is the responsibility of the user to ensure proper safety practices are utilized. Always take necessary precautions and use proper protective equipment when dealing with compressed gasses, compressed hydraulic fluid, pinch points and electricity.

Safety notices are presented in this manual in three forms (Warning, Caution and Note) as follows:

### **WARNING**

Alerts user of potential danger; failure to follow the warning notice could result in serious personal injury or death.

---

### **CAUTION**

Identifies precautions the user must take to avoid personal injury or equipment damage.

---

### **NOTE:**

Highlights information critical to the user's understanding of the ECAT system installation or operation.

---

## 1.4 Abbreviation Definitions

Abbreviations used in this manual and their definitions are listed in the table below:

**Table 1. Abbreviation Definitions**

Abbreviation	Definition
IOM	Installation Operation Manual
ESD	Emergency Shutdown
FS	Fail-Safe
DA	Double-Acting
MAWP	Maximum Allowable Working Pressure
MOP	Maximum Operating Pressure
MCC	Motor Control Center
LS	Limit Switch
PS	Pressure Switch
NC	Normally Closed
NO	Normally Open
CCW	Counterclockwise
CW	Clockwise
OL	Overload
PPE	Personal Protective Equipment
GAD	General Arrangement Drawing
SOV	Solenoid Valve



# Section 2: Installation

## 2.1 Preparation

### 2.1.1 Delayed Usage

If for any reason the system is not to be installed immediately, Emerson recommends the following procedures. Failure to comply with recommended procedures could lead to actuator malfunction and possibly void the warranty. For storage procedures exceeding one year, consult Emerson for further recommendations.

As shipped from the factory, the ECAT system is an inherently weatherproof unit, providing that all compartment covers and cable entry plugs remain intact. The system should be immediately stored in a clean, dry warehouse, free from vibration and rapid temperature changes, until it can be installed and energized.

If the system must be stored outside, store it off the ground at an elevation sufficient to prevent it from being immersed in water or buried in snow. Check for any unpainted or exposed metal surfaces and make sure they are protected with a coating of grease to prevent any corrosion. Cover the system to prevent damage from site debris.

### 2.1.2 Tools and Materials Required

To complete these procedures, you will need the following documentation for the ECAT system and items indicated in the table below:

- General Arrangement Drawing
- Bill of Material
- ECAT System Schematic
- System Wiring Diagram

**Table 2. Tools and Material Requirements**

Tools and Material Requirements
Primary power source for the ECAT (check the ECAT System Electrical Diagram for requirements)
Supplemental quantity of hydraulic fluid, if needed (See Section 2.7, Hydraulic Fluid and ECAT specification, for required fluid type)
Hand tools: complete complement of open end (SAE and metric) wrenches; screwdrivers: Phillips head and flat blade; and a set of hex wrenches
Chains and lifting straps that are inspected and certified for the weight of the ECAT system (check shipping weights)
Sealant for all cable and conduit entries (approvable by the National Electric Code or your country standard and applicable local codes)

## 2.2 Valve Preparation

- 2.2.1 Remove Valve Gearing, if equipped.
- 2.2.2 If valve is equipped with stops, remove valve stem extension housing. Examine the valve stops to ensure no foreign material is present that would restrict normal travel of the valve. Some valves are equipped with inspection ports in the valve housing for ease in examining the stops.
- 2.2.3 Check alignment of stem key slot to the position of the valve. Normally with the valve in the open position, the key slot is in line with the run of the pipeline. With the valve in the closed position, the key slot should be 90° to the run of the valve.
- 2.2.4 The ECAT system may be mounted to the valve at any time regardless of whether the valve is under pressure.

## 2.3 System Preparation

- 2.3.1 Once the ECAT system is uncrated and cleaned for installation, check to ensure there will be no interference with piping or other structure when the system is properly mounted to the valve.
- 2.3.2 Check that all mounting materials such as fasteners, adapters, brackets, etc., are on hand and ready for use.
- 2.3.3 Check the actuator and valve to see that they are in the same relative position, that is either open or closed. If the actuator must be moved, use the hand pump provided.
- 2.3.4 It is critical that the accumulator is charged with natural gas pipeline pressure prior to operating the equipment. Refer to Section 2.8 for charging instructions.

---

**NOTE:**

Failure to charge the accumulator may cause the accumulator to not function properly.

---

## 2.4 Lifting the ECAT System

---

**NOTE:****All ECAT Considerations**

When handling any ECAT system, be aware of tubing, accessories, hand pump, accumulators and control enclosures. Straps and chains can become entangled and cause damage to these components.

---

**NOTE:**

Do not use hydraulic tubing and electrical cable for lifting.

---

**⚠ CAUTION**

Be sure to use appropriately rated crane/hoist and straps/chains to raise and lower the actuator.

---

### 2.4.1 Shafer Rotary Vane Actuator Lifting

Use the integrated lifting eyes only to lift and move the ECAT system.

---

**Figure 1. ECAT System Mounted on the Shafer Rotary Vane Actuator**

Lift at these lift points only

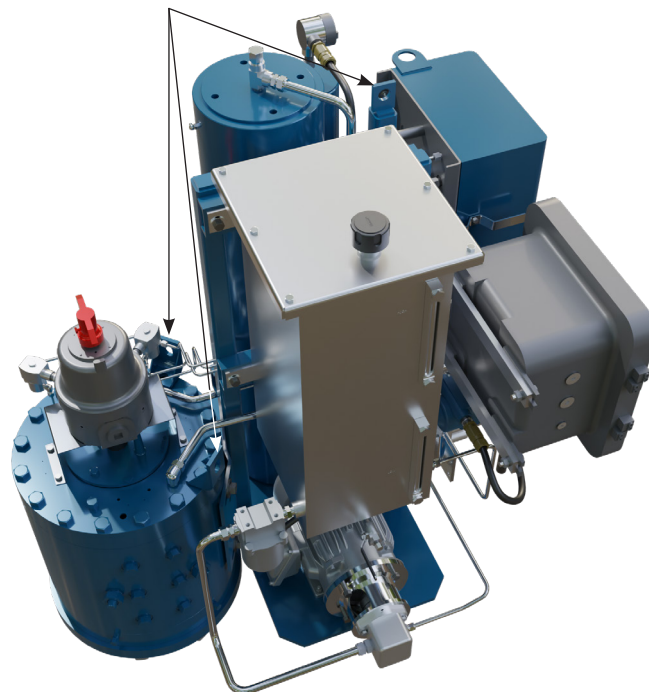

---

**Figure 2. ECAT System Mounted on the Shafer Rotary Vane Actuator**

---

**⚠ CAUTION**

Never lift the actuator with a valve attached. Always handle actuator/valve assemblies by attaching lifting equipment to the valve only.

---

## 2.5 Installing the ECAT System on the Valve

The system will be bolt-mounted directly to a bracket or adapter that will be bolted securely to the mounting flange top works of the valve.

- 2.5.1** Check to see that the dimensions of the bracket or adapter are suitable for use with the valve mounting flange and stem.
- 2.5.2** Check valve direction of rotation and the actuator direction of rotation to see they match (for example: CW = close, CCW = open).
- 2.5.3** Check to see the actuator and valve are in the same relative position (see 2.3.3).
- 2.5.4** Check all mounting surfaces, they must be clean and free of debris to permit proper fit up.
- 2.5.5** Prior to mounting, grease the coupling bore and the bore of the actuator.

---

**NOTE:**

Do not apply grease to the mounting flange surfaces on the valve or the adapter.

---

- 2.5.6** Install the stem key and grease it (keys may be held in place with tape).
- 2.5.7** Install the coupling onto the stem and stem key.
- 2.5.8** Install the coupling key and grease it.
- 2.5.9** Carefully align the coupling and key to the bore and keyway in the actuator and slide the actuator onto the coupling until the adapter (bracket) bottoms out on the valve bonnet.
- 2.5.10** Use the required fasteners to firmly attach the adapter to the valve bonnet. Tighten the fasteners to their manufacturer's recommended maximum torque (dry or lubricated).

## 2.6 Setting the Stroke Limit Stops

Refer to the installed actuator installation and operation manual for specific instructions on setting the actuator stops.

## 2.7 Hydraulic Fluid

The ECAT is shipped with the reservoir filled to operation level. Before commissioning and periodically afterwards, check to ensure the fluid level is correct. The reservoir is equipped with a sight gauge. Should hydraulic fluid need to be added or replaced, use only factory approved hydraulic fluid.

This specification covers hydraulic fluids which are approved by engineering for use in the ECAT system at a temperature range from -50 to 140 °F / -46 to 60 °C.

### 2.7.1 Approved Fluids

- Standard Fluid [use with -20 to 140 °F / -29 to 60 °C applications]
  - ConocoPhillips Megaflow® AW HVI Hydraulic Oil 22
  - Shell Tellus S2 V 22
  - Mobil DTE 10 Excel® 22
- Low Temperature Fluid [use with -50 to 140 °F / -46 to 60 °C applications]
  - Mobil Univis® HVI 13

Although other brands of fluid matching the same specifications may be used, to maintain the warranty and ensure trouble free operation, always check with the factory before substituting any other fluid.

## 2.8 Accumulator

### 2.8.1 Introduction

The ECAT system is equipped with a hydraulic accumulator. As the accumulator utilizes the pressurized pipeline gas, the ECAT will be in an unpressurized state when shipped from the factory.

When using this procedure, refer to the ECAT System General Arrangement drawing and Hydraulic Schematic for the unit being worked on. Schematics shown in this document are for illustration purposes only.

### WARNING

This unit contains high-pressure hydraulic fluid and high-pressure pipeline gas. Exercise caution when performing any type of maintenance. Wear proper safety attire and required personal protective equipment, including safety glasses.

**2.8.2 Pneumatic Isolation Valve and Blow-Down Valve**

The ECAT is equipped with a Pneumatic Isolation Valve (83) and Blow-Down Valve (87). This is a one-piece assembly block and bleed valve as shown below.

**Figure 3. Pneumatic Isolation Valve and Blow-Down Valve**

Pneumatic Isolation Valve – Blue handle  
Pneumatic Blow-Down Valve – Red handle

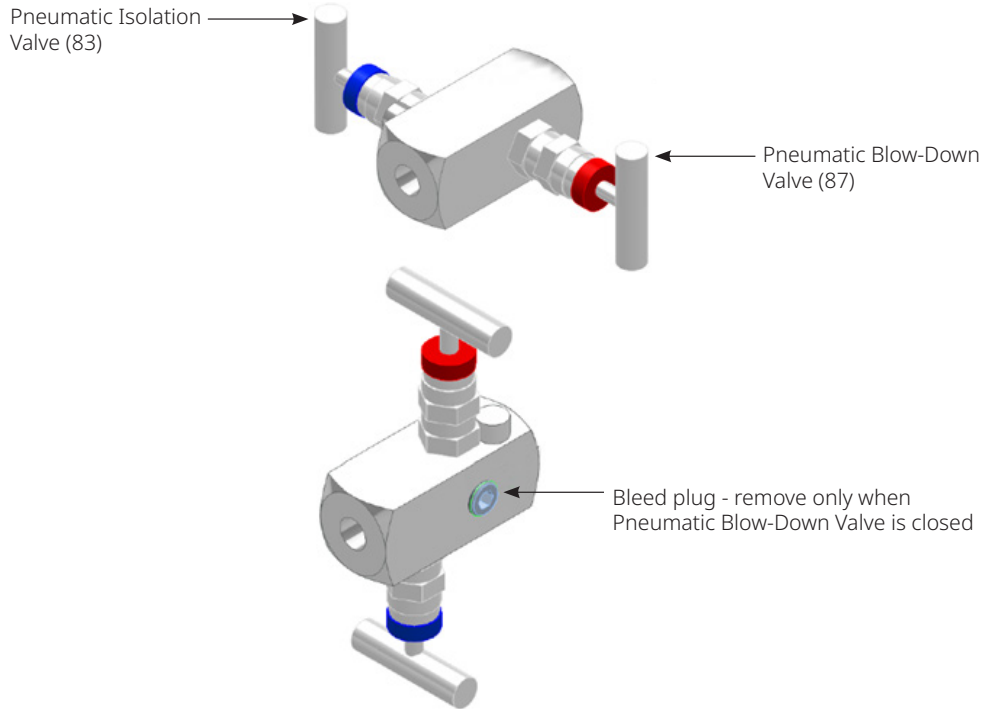

**2.8.3 Pipeline Gas connections – Refer to schematic 12308-S**

- a. Ensure Pneumatic Isolation Valve (83) is closed.
- b. Connect the pipeline gas to the Pneumatic Isolation Valve (83).
- c. Ensure the Pneumatic Blow-Down Valve (87) is closed. Remove the bleed plug from blow down valve port.
- d. Slowly open the Pneumatic Isolation Valve (83).
- e. Slowly open Pneumatic Blow-Down Valve (87) to purge the pneumatic side of the control of air. Close Pneumatic Blow-Down Valve (87). Install the bleed plug to the blow down valve port.
- f. Ensure the Pneumatic Isolation Valve (83) remains open when the ECAT is operational.

**NOTE:**

The pneumatic side of the ECAT is pressurized and the Pneumatic Isolation Valve (83) should remain open until maintenance of the ECAT is required.

**Figure 4. Typical ECAT Accumulator System (1)**

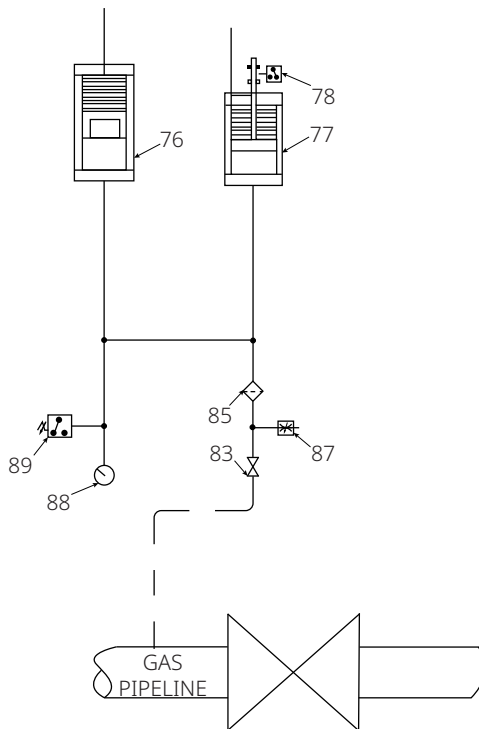

**Table 3. Typical ECAT Accumulator System (1)**

Part Number	Part Name
76	Accumulator (Piston Type)
77	Thermal Volume Controller
83	Pneumatic Isolation Valve
87	Pneumatic Blow-Down Valve



**2.8.4 Upstream and downstream Pipeline Gas connections – Refer to schematic 12501-S**

- a. Ensure Pneumatic Isolation Valve (83) is closed.
- b. Connect the upstream and downstream pipeline gas to Shuttle Valve (82).
- c. Ensure the Pneumatic Blow Down Valve (87) is closed. Remove the bleed plug from blow down valve port.
- d. Slowly open the Pneumatic Isolation Valve (83).
- e. Slowly open Pneumatic Blow-Down Valve (87) to purge the pneumatic side of the control of air. Close Pneumatic Blow-Down Valve (87). Install the bleed plug to the blow down valve port.
- f. Ensure the Pneumatic Isolation Valve (83) remains open when the ECAT is operational.

**NOTE:**

The pneumatic side of the ECAT is pressurized and the Pneumatic Isolation Valve (83) should remain open until maintenance of the ECAT is required.

**Figure 5. Typical ECAT Accumulator System (2)**

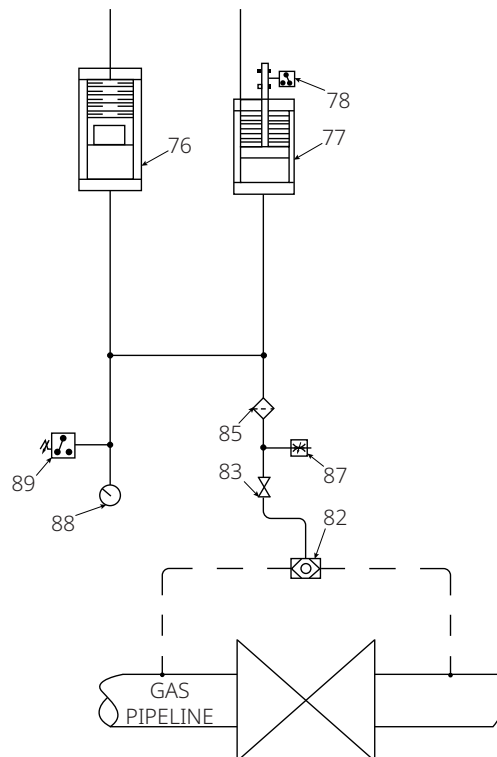

**Table 4. Typical ECAT Accumulator System (2)**

Part Number	Part Name
76	Accumulator (Piston Type)
77	Thermal Volume Controller
82	Shuttle Valve
83	Pneumatic Isolation Valve (Lockable)
87	Pneumatic Blow-Down Valve

**2.8.5 Pneumatic Fitting Leak Check**

With pipeline pressure applied to the pneumatic side of the ECAT circuit, check to ensure there are no leaks at the fittings. Use a leak detection product such as Snoop® Liquid Leak Detector from Swagelok or comparable.

If any leaks are detected, close Pneumatic Isolation Valve (83) and open Pneumatic Blow-Down Valve (87) to vent all pressure from the circuit.

Repair any leaks present and repeat steps from Section 2.8.3 or 2.8.4

### **WARNING**

This unit contains high-pressure hydraulic fluid and pipeline gas. Exercise caution when performing any type of maintenance. Wear proper safety attire and required personal protective equipment, including safety glasses. Ensure the accumulator has been drained of all hydraulic and pipeline gas pressure before attempting any repair.

## Section 3: Electrical Connections

### 3.1 Main Electrical Connections

Refer to the project specific wiring diagram for the electrical connections to the Motor Control Center (MCC).

### 3.2 Sealing Cable/Conduit Entries

Seal the cable and conduit entries in accordance with the National Electric Code or your country standard and applicable local codes. All conduit entries should be sealed against the site environment. All unused conduit entries must be sealed with threaded metal plugs.

#### **WARNING**

Always verify electrical power is disconnected before opening the motor starter enclosure. Ensure all customer site location electrical lock out/tag out procedures are followed as required.

# Section 4: Set-up/Start-up Procedure

In addition to this set-up/start-up procedure, the following documentation will be necessary to fulfill all set-up and start-up requirements.

1. General Arrangement drawing
2. Bill of Material
3. Schematic drawing
4. Wiring Diagram drawing

When using these instructions, refer to the schematic diagram, wiring diagram, general arrangement drawings for the ECAT and the certified bills of material.

Numbers in [ ] correspond to components labeled on the wiring diagram. Numbers in ( ) correspond to components labeled on the schematic diagram. Information in (( )) is descriptive.

When the ECAT is delivered to the job site, it has been both pressure and function tested. The oil reservoir was filled to operation level when it shipped from factory.

## 4.1 Preparation

### 4.1.1 Safety First

#### WARNING

##### Hydraulic Pressure

Ensure that test personnel and witnesses are properly informed of the hazards involved with high pressures and the proper safety barriers are employed. Never check for leakage using your fingers or hands. Fluid under high pressure can inject into the skin and cause severe damage or death. Always use an implement such as a piece of paper or shop rag.

#### WARNING

##### Safety Equipment

All personnel in the testing area must always wear safety glasses.

### 4.1.2 Material and Equipment for Start-up and Set-up

To complete this procedure, you will also need the following materials and equipment:

**Table 5. Required Material and Equipment**

Required Material and Equipment
Miscellaneous fittings, adapters and hand tools: complete complement of open end ((SAE and metric)) wrenches; screwdrivers: Phillips head and flat blade; and a set of hex wrenches
Primary Power Source for the ECAT ((check the ECAT System Electrical Diagram for requirements))
Supplemental quantity of hydraulic fluid, if needed ((See Section 2.7, Hydraulic Fluid, and ECAT specification for required fluid type))

## 4.2 Initial Check of the Unit

- 4.2.1 Check to ensure all hydraulic tube fittings are tight. Vibration during shipment may have loosened connections.
- 4.2.2 Visually inspect the unit to make sure tubing, hand valves, gauges and other equipment have not been damaged.
- 4.2.3 Using the actuator control schematic drawing, verify that the Flow Control Valves are fully opened ((turn stem completely counterclockwise)).
- 4.2.4 Ensure System Bypass Hand valve (71) is closed.
- 4.2.5 Ensure Power Oil Isolation Valve (73) is closed.

## 4.3 Initial Connections

Electrical connections should have been made to the MCC. If power is not connected, follow the instructions under Section 3, Electrical Connections, before continuing.

### CAUTION

Before the actuator is stroked, ensure the reservoir has been filled with fluid to the proper level (see Section 2.7, Hydraulic Fluid).

## 4.4 Initial Pre-Charge

Refer to Section 2.8, Accumulator for the pre-charge setup of the ECAT.

## 4.5 Initial Reservoir Fill

Ensure the ECAT Oil Reservoir (60) is filled to the proper oil level. Remove the reservoir breather (61) if fluid needs to be added to the reservoir.

## 4.6 Hydrostatic Pressure/Function Test

The Accumulator has already been hydrostatic tested per ASME requirements and does not require re-testing. This test is to discover if any leaks have developed in the hydraulic fittings during shipment.

### CAUTION

The ECAT Motor Control Center (MCC) is equipped with a [Hand (Jog)/Off/Auto] selector switch. Turning the selector switch to the Hand (Jog) position will operate the motor regardless of the Motor Start/Stop Switch. The Hand (Jog) position is intended to confirm the Motor rotation direction and for troubleshooting purposes only. Do not leave the selector switch in the Hand (Jog) position long term.

- 4.6.1 Ensure Pneumatic Isolation Valve (83) is open.
- 4.6.2 Ensure the Power Oil Isolation Valve (73) is open.
- 4.6.3 Open the System Bypass Valve (71).
- 4.6.4 Verify all electrical connections are made per Section 3 of this procedure. Ensure the [Hand (Jog)/Off/Auto] selector switch is set at Off. Turn main power on to the ECAT unit. The Power On light on the MCC should be illuminated.
- 4.6.5 Check rotation of the motors by jogging the [Hand (Jog)/Off/Auto] selector switch to [Hand (Jog)]. The motor must rotate clockwise when viewed from the back of the motor.
- 4.6.6 Turn the [Hand (Jog)/Off/Auto] selector switch, on the MCC, to the [Auto] position. The motor will start-up and run.

### CAUTION

Observe entire system for leakage and be prepared to stop the motor immediately should any develop. Make any needed corrective actions.

- 4.6.7 Allow the Electric driven Hydraulic Pump (67) to run several minutes circulating fluid from the reservoir through the System Bypass Valve (71) and back to the Reservoir (60) to eliminate most of the air in the hydraulic lines. Loosen, but do not remove, the pipe plugs located on the hydraulic side of the Accumulator (76) and Thermal Volume Controller (77), to purge the system of air. Tighten the plugs when air is no longer present.
- 4.6.8 With the motor running, slowly close the System Bypass Valve (71). Check Hydraulic Pressure Gauge (79), if supplied, or the pressure gauge located in the hydraulic control, to observe pressure build up in the hydraulic lines and fluid will start to fill the Accumulator.
- 4.6.9 Observe the Level Viewer (62) to ensure enough fluid is present to fill the Accumulator (76). In the event the fluid level drops to the trip point of the Level Switch (63), the Electric Motor (69) will stop. Add fluid to the Reservoir (60) if needed.
- 4.6.10 Allow the Pump to run filling the Accumulator until the Thermal-Volume Controller moves and trips the Motor Start/Stop Switch (78) stopping the Electric Motor.
- 4.6.11 Slowly open the System Bypass Valve (71) and relieve the pressure in the Accumulator (76), Thermal Volume Controller (77) and hydraulic lines until the electric Motor starts to run. Close the System Bypass Valve. Allow the motor to run until the pump fills the Accumulator and the Thermal-Volume Controller shuts the motors off.
- 4.6.12 Perform step 4.6.11, 3 to 4 times so that air can be worked out of the system. Allow the Electric Driven Pump (67) to run until it is stopped by the Motor Start/Stop Switch (78).
- 4.6.13 Maintain this pressure for 5 minutes while visually inspecting the hydraulic system for leaks. Corrective action must be taken for any leaks found.

### CAUTION

Relieve system pressure before tightening any leaking fittings.

- 4.6.14 Turn the [Hand (Jog)/Off/Auto] selector switch to [Off].
- 4.6.15 Open the System Bypass Hand Valve (71) and relieve the pressure in the hydraulic lines.
- 4.6.16 Close the System Bypass Hand Valve (71).

The hydrostatic test is now completed.

## 4.7 Final Start-up Procedure

The system should already have the pipeline gas pressure applied to the pneumatic side of the system per Section 2.8. Verify the connections and pressure reading on Pneumatic Pressure Gauge (88), if supplied.

The header lines up to Power Oil Isolation Valve (73) should be filled and purged of all air per Section 4.6.

Under normal operating conditions, the [Hand (Jog)/Off/Auto] selector switch will be set to (Auto).

Refer to the Actuator and Control IOM for specific steps in operating the actuator and control in conjunction with the ECAT hydraulic system.

## 4.8 Level Switch Testing

The ECAT system is supplied with a vibrating fork Level Switch (63). The level switch is equipped with a magnetic test point marked on the side of the housing to allow a functional test in the ECAT system. By touching a magnet to the target, the output from the level switch will change state while the magnet is present.

The level switch test can be performed while the Hydraulic Pump (67) is running, verifying the pump will stop and the Low Oil Level light on the MCC illuminates.

The level switch test can be performed while the Hydraulic Pump (67) is not running, verifying the Low Oil Level light on the MCC illuminates only.

## 4.9 Optional Instrumentation

The ECAT system can be supplied with a Hydraulic Pressure Switch (Low System Pressure) (80) and/or Pneumatic Pressure Switch (Low Pressure) (89).

## 4.10 Local Hand Pump (To Open or Close the Actuator)

To manually stroke the actuator, either open or closed, turn the handles of the 3-way two position isolation valves (if equipped) to a horizontal position. Select the appropriate knob on the selector valve located on the hand pump. This knob is selected by pressing inward toward the pump center.

---

**NOTE:**

The pump has a label designating which knob is open and close.

---

Using the supplied pump handle, raise the hand pump clevis, which will draw hydraulic fluid into the pump. Pull the handle downward to discharge hydraulic fluid into the actuator. Repeat this process until the actuator reaches its end of stroke.

When the pumping cycle is completed, manually pull the selector knob back out to the neutral position. Depress the manual relief valve located on the top of the selector valve on the pump and pull the pump ram back into the pump body. Turn the handles of the 3-way two position isolation valves (if equipped) back to a vertical position.

The pump is now relieved of pressure and back in neutral. The automatic features of the control circuit can now be used.

In the event the hand selector knob is not returned to neutral, after hand pumping, pressure in the cylinder line marked OPEN or the cylinder line marked CLOSE will pilot the selector valve to neutral.

**Figure 6. 3-Way Two Position Isolation Valves (Horizontal Position)**

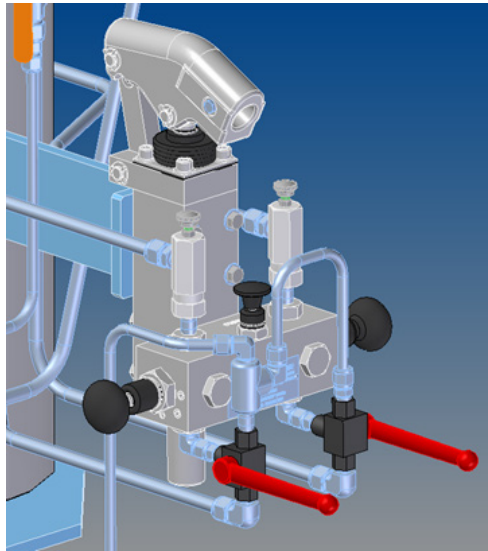

- 3-Way Two Position Isolation Valves shown in the horizontal position – The actuator is ready to be hand pumped to the opened or closed position.

**Figure 7. 3-Way Two Position Isolation Valves (Vertical Position)**

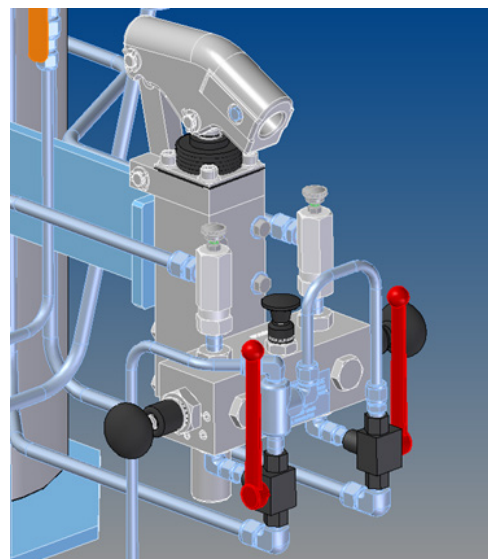

- 3-Way Two Position Isolation Valves shown in the vertical position – Return the handles to this position to place ECAT back into normal use.



## 4.11 Shafer Speed Control Setup

The ECAT is equipped with opening and closing speed controls located on the manual hand pump. To increase the speed of operation of the actuator, turn the speed control knob counterclockwise while looking down on the speed control knob. To decrease the speed of operation of the actuator, turn the speed control knob clockwise while looking down on the speed control knob.

When the desired stroking speed is obtained, tighten the provided locknut to ensure the actuator stroking speed does not vary over time.

**Figure 8. Speed Control Rotation Diagram**

Rotate counterclockwise to increase atuator stroking speed.

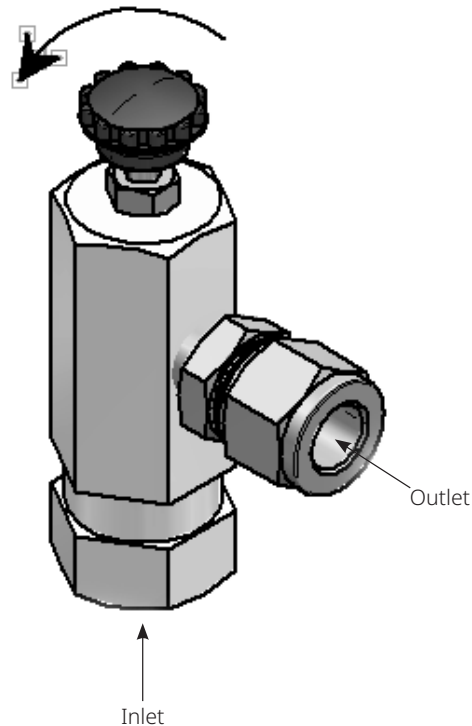

## 4.12 ECAT Pump Discharge Manifold Assembly

The ECAT is equipped with a pump discharge manifold assembly which includes the Pump Discharge Check Valve (70), the System Bypass Hand Valve (71) and the System Hydraulic Relief Valve (72).

The System Hydraulic Relief Valve (72) is factory set and is equipped with a tamper resistant cover to prevent the relief valve from being adjusted.

The Pump Discharge Check Valve (70) is a cartridge style check valve assembly and can be removed and replaced if any leakage occurs.

The System Bypass Hand Valve (71) is a cartridge style valve that can be opened and closed with a 5/32 in. hex key. Approximately five turns counterclockwise will open the valve fully. The protection cap must be removed to open/close the System Bypass Hand Valve (71) and should be reinstalled when operation of the valve is not required.

**Figure 9. System Bypass and Relief Valve Diagram**

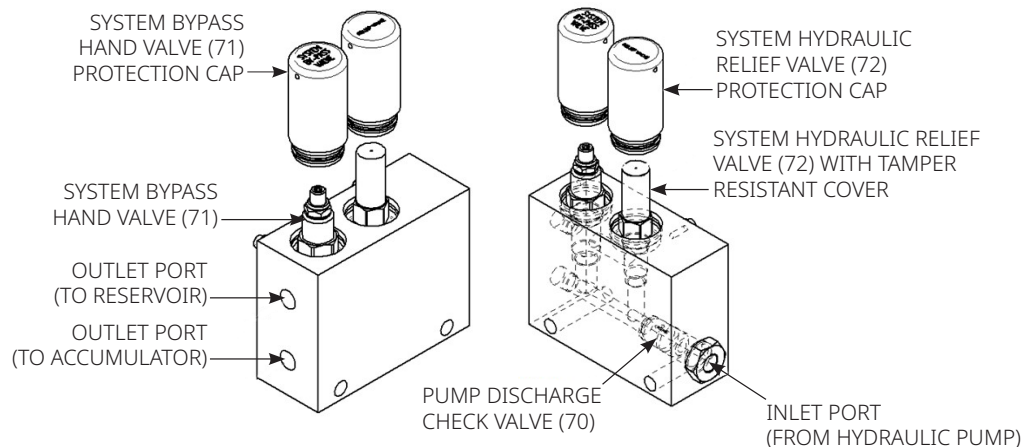

# Section 5: Troubleshooting

## **WARNING**

To prevent personal injury, all hydraulic pressure must be relieved from the accumulator before opening any tube lines or attempting replacement operations below. Ensure all customer site location electrical lock out/tag out procedures are followed as required.

Of all the system components, the actuator itself is least likely to malfunction and requires the most time and effort to service.

**Table 6. Troubleshooting**

Symptoms	Possible Reason
ECAT does not turn ON	<ol style="list-style-type: none"> <li>1. Ensure voltage is adequate to the unit.</li> <li>2. Check to see that the electrical power is connected to the correct terminals.</li> <li>3. Circuit breaker is tripped off.</li> </ol>
ECAT is ON, but motor does not run	<ol style="list-style-type: none"> <li>1. Ensure the Hand (Jog)/Off/Auto switch is in the proper position.</li> <li>2. Ensure the customer field power wiring is an adequate size.</li> <li>3. Power supply is insufficient.</li> <li>4. Check to see if thermal overload is tripped.</li> <li>5. Ensure the Motor Start/Stop Switch (78) is set properly.</li> </ol>
ECAT motor runs, but fails to develop sufficient pressure to open the valve	<ol style="list-style-type: none"> <li>1. Low fluid level in reservoir.</li> <li>2. Wrong motor shaft rotation.</li> <li>3. Manual bypass valve (71) is open.</li> <li>4. The System Hydraulic Relief Valve (72) is cracking open. Check to ensure setting set to factory setting.</li> </ol>

Should any issue be experienced besides the symptoms noted above, please consult factory.

Important check points for automatic operation of the ECAT:

1. Ensure oil level is at the proper level.
2. Ensure bypass valve (71) is closed.

## Section 6: Maintenance

### 6.1 Storage Procedures

The ECAT should be immediately stored in a clean, dry warehouse, free from vibration and rapid temperatures changes, until it can be installed and energized. If the system must be stored outside, it should be stored off the ground at an elevation sufficient to prevent it from being immersed in water or buried in snow and covered to prevent damage from site debris.

If the system is not attached to a valve, the preferred orientation is with the motor and electrical compartment horizontal. Care should be taken to plug all open ports on the system and all controls to keep out foreign contaminants.

### 6.2 Service Interval

Routine maintenance is generally unnecessary. Normally recommended service interval for Shafer/Bettis actuators is five years or maximum actuator seal life cycle, whichever occurs first.

---

**NOTE:**

Storage time is considered as part of the Service Interval time.

---

It is recommended that Service Kits be ordered approximately three (3) months prior to scheduled maintenance to assure availability.

Observe the function of the Accumulator (76) and Thermal Volume Controller (77) on an annual service interval to ensure they are functioning properly and holding hydraulic pressure.

### 6.3 Lubrication Requirements

---

**NOTE:**

Lubricant, other than listed below should not be used without prior written approval of Emerson's Product Engineering.

---

Hydraulic fluids, other than those listed below should not be used without prior written approval of Emerson's Product Engineering.

Standard temperature service (-20 to 140 °F / -29 to 60 °C), use ConocoPhillips Megaflo AW HVI 22 Fluid, reference Section 2.7.1.

Low temperature service (-50 to 140 °F / -46 to 60 °C), use Mobil Univis HVI 13 fluid.

## 6.4 Maintenance Instructions

Listed below are some of the issues that may arise under normal conditions, and their possible causes and solutions.

- Tools:
  - The tools required for any service or installation are S.A.E.
- Issue:
  - Pump turning on and off frequently without actuator cycling and no loss of hydraulic fluid from the oil reservoir.
  - Since the ECAT system and the actuator form a closed loop system, the most probable cause is an internal leak.
  - Close the Power Oil Isolation Valve (73). This will tell if the leak is in the hydraulic power unit or in the actuator control. If the pumps continue to run after a 5-minute period, the leak is in the hydraulic power unit.

### WARNING

Observe all gauges to ensure no pressure is trapped in any line to be disconnected.

#### 6.4.1 Leak Within the ECAT System

##### NOTE:

The Power Oil Isolation Valve (73) must be closed.

1. Open the System Bypass Hand Valve (71) and drain all pressure from the system.
2. Disconnect the tubing of the System Hydraulic Relief Valve (72) and System Bypass Hand Valve (71) outlet and install a tubing cap at the end of the tube.
3. Connect a hose or tube at the System Hydraulic Relief Valve (72) and System Bypass Hand Valve (71) outlet and route to a drain pan or bucket.
4. Start the Hydraulic Pump (67) and observe if any fluid is coming out of the System Hydraulic Relief Valve (72) and System Bypass Hand Valve (71) outlet. If oil begins to drip from the outlet port at a high rate of speed, the relief valve should be replaced.
5. Should the System Hydraulic Relief Valve (72) and System Bypass Hand Valve (71) outlet show no sign of leakage, stop the Hydraulic Pump (67). Reconnect tubing to the System Hydraulic Relief Valve (72) and System Bypass Hand Valve (71) outlet.
6. Open the System Bypass Hand Valve (71) and relieve pressure from the lines.
7. Test the Pump Discharge Check Valve (70) on the discharge side of the hydraulic pump for leakage. Ensure the System Bypass Hand Valve (71) is closed.
8. Start the Motor (69)/Hydraulic Pump (67) and allow the ECAT system to reach maximum operating pressure. The Motor Start/Stop Switch (78) and Thermal Volume Controller (77) will stop the Motor (69)/Hydraulic Pump (67).
9. Allow the ECAT system to sit for ten minutes. This will enable pressure to decay between the Hydraulic Pump (67) outlet and the Pump Discharge Check Valve (70) inlet.
10. Place a drain pan, to catch the fluid lost, under the pump discharge and remove the tubing between the pump discharge and the Pump Discharge Check Valve (70).

11. If back-flow through the Pump Discharge Check Valve (70) is experienced, the check valve is leaking and should be repaired or replaced. Open the System Bypass Hand Valve (71) and relieve pressure from the lines.
12. If the Pump Discharge Check Valve (70) proves not to be leaking, Open the System Bypass Hand Valve (71) and relieve pressure from the lines. Reassemble the removed tubing.
13. Close the System Bypass Valve (71).

With the System Bypass Valve, the System Relief Valves and the Check Valves eliminated as sources of the leakage, the next area of focus is the Accumulator and Thermal Volume Controller.

#### **6.4.2 Accumulator and Thermal Volume Controller**

The Accumulator (76) and Thermal Volume Controller (77) are a piston type with the pipeline natural gas used as the charging gas. Under normal working conditions these should require no maintenance. However, should their performance indicate that a problem could exist, the piston seal is the only replaceable component.

To examine the Accumulator (76) and Thermal Volume Controller (77) to see if the fluid is bypassing the piston seal, the following procedures should be followed:

1. Prevent the Hydraulic Pump (67) from running by turning the motor control switch to Off.
2. Close the Power Oil Isolation Valve (73).
3. Open the System Bypass Valve (71) and drain all pressure from the system. Close the System Bypass Valve (71).
4. Close the Pneumatic Isolation Valve (83).
5. Slowly open the Pneumatic Blow-Down Valve (87) to relieve the ECAT system of natural gas charging pressure.
6. Place a pan under the Pneumatic Blow-Down Valve (87) to catch any fluid in the event of the Accumulator (76) and/or Thermal Volume Controller (77) piston seal leaking.
7. Start the Hydraulic Pump (67) and observe if any fluid is coming out of the Pneumatic Blow-Down Valve (87).
8. If fluid is discharging from the Pneumatic Blow-Down Valve (87), stop the Hydraulic Pump (67) and open the System Bypass Hand Valve (71) to drain all pressure from the system.
9. Disconnect the hydraulic tubing from the Thermal Volume Controller (77) and install a tubing cap on the end of the tube.
10. Start the Hydraulic Pump (67) and observe if any fluid is coming out of the Pneumatic Blow-Down Valve (87).
11. If fluid is discharging from the Pneumatic Blow-Down Valve (87) then the piston seal of the Accumulator (76) is damaged and should be replaced.
12. Stop the Hydraulic Pump (67) from running by turning the motor control switch to off.
13. Open the System Bypass Hand Valve (71).
14. Reconnect the hydraulic tubing onto the Thermal Volume Controller (77).
15. Disconnect the hydraulic tubing from the Accumulator (76) and install a tubing cap on the end of the tube.
16. Close the System Bypass Hand Valve (71).
17. Start the Hydraulic Pump (67) and observe if any fluid is coming out of the Pneumatic Blow-Down Valve (87).

18. If fluid is discharging from the Pneumatic Blow-Down Valve (87) then the piston seal of the Thermal Volume Controller (77) is damaged and should be replaced.
19. Stop the Hydraulic Pump (67) from running by turning the motor control switch to off.
20. Open the System Bypass Hand Valve (71).
21. Close the Pneumatic Blow-Down Valve (87).
22. Remove and repair the piston seal of the Accumulator (76) and/or the Thermal Volume Controller (77). Refer to ECAT Accumulator Seal Replacement Instructions, VA-DC-000-2255 or ECAT Thermal Volume Controller Seal Replacement Instructions, VA-DC-000-2256.

#### 6.4.3 Hydraulic Suction Strainer Element Cleaning

The Suction Strainer with Bypass (65) includes a pressure relief valve that protects against excess pressure that can build up when a cartridge is clogged. It is important to clean the filter element when required. If a filter element needs cleaning, follow the instructions below.

#### WARNING

The hydraulic pump must not run during this procedure. Ensure the pump is prevented from running until the procedure is complete. Ensure all customer site location electrical lock out/tag out procedures are followed as required.

#### NOTE:

The Suction Strainer with Bypass (65) should be on a yearly maintenance schedule and the element should be removed and cleaned. Inspect the element prior to cleaning. If the element is damaged replace with a new element.

1. Place a drain pan under the filter to catch any fluid loss.
2. Loosen the element bowl and remove it from the filter head.
3. Remove the filter element and place the new, clean element in the bowl, centering it on the element locator.

#### NOTE:

Clean the element by swishing in non-caustic solvent, then blow dry from inner diameter to outer diameter with compressed air.

#### NOTE:

Inspect the O-ring seal and replace if necessary.

4. Return the element bowl to the filter head. Tighten to the required torque per the filter manufacturer's instructions.
5. The filter is now ready to be placed back into service.

#### 6.4.4 Relief Valves

The ECAT system is protected by a System Hydraulic Relief Valve (72). This relief valve protects the system from excess hydraulic pressure caused by the pump or thermal expansion of the oil. This relief valve is factory set to prevent damage to any of the system components and should not be adjusted. This valve requires no maintenance and the recommended replacement interval is 2 years.

### 6.4.5 Thermal Volume Controller Target and Switch Adjustment

The following instructions detail the setting and adjustment of the Motor Start/Stop Switch (78) and target.

#### **WARNING**

The target is not required to make physical contact with the switch for the switch to change state. Damage to the target and/or switch may occur if contact is made.

- **Fixed Position Limit Switch – Adjustment of Target Only**

This section details the steps required to set the target of the Thermal Volume Controller (77) only.

1. Ensure the [Hand (Jog)/Off/Auto] switch is set to [Off].
2. Slowly open the System Bypass Hand Valve (71) to ensure all pressure is removed from the system.
3. Adjust the target on the Thermal Volume Controller (77) rod with approximately 2 mm / 1/16 inch space between the target and the limit switch. Tighten the hex nut against the target mounting plate by hand. It may be necessary to adjust the threaded rod on the end of the Thermal Volume Controller (77) rod. Tighten the hex nut on the threaded rod against the Thermal Volume Controller (77) rod by hand.
4. Place the [Hand (Jog)/Off/Auto] switch to [Auto]. The Motor (69)/Hydraulic Pump (67) should start. If the Motor (69)/Hydraulic Pump (67) does not start, adjust the target accordingly.
5. With the Motor Start/Stop Switch (78) and target properly set, and the Motor (69)/Hydraulic Pump (67) running, close the System Bypass Hand Valve (71).
6. Allow the system to fully charge with hydraulic fluid. When the Accumulator (76) is full the Thermal Volume Controller (77) will fill with fluid and the target will move off of the switch. Verify the motor/pump stops.
7. Using an open end wrench, tighten the hex nuts to secure the target mounting plate to the threaded rod and threaded rod to the Thermal Volume Controller (77) rod.

If the motor/pump does not stop place the [Hand (Jog)/Off/Auto] switch to [Off] and repeat steps 2 through 7. Repeatedly cycle the system by opening the System Bypass Hand Valve (71). This will cause fluid within the Thermal Volume Controller (77) to return to the hydraulic reservoir and start the motor/pump. The entire amount of fluid within the Thermal Volume Controller (77) and Accumulator (76) does not need to be emptied, just enough to start the motor/pump and verify the switch setting is correct.



- **Adjustable Position Limit Switch and Target Assembly**

This section details the steps required to set the limit switch and the target of the Thermal Volume Controller (77).

1. Ensure the [Hand (Jog)/Off/Auto] switch is set to [Off].
2. Slowly open the System Bypass Hand Valve (71) to ensure all pressure is removed from the system.
3. Adjust the Motor Start/Stop Switch (78) and the target on the Thermal Volume Controller (77) rod with approximately 2 mm / 1/16 inch space between the target and the limit switch. Tighten the hex nut against the target by hand. It may be necessary to adjust the threaded rod on the end of the Thermal Volume Controller (77) rod. Tighten the hex nut on the threaded rod against the Thermal Volume Controller (77) rod by hand. Tighten the jam nuts of the Motor Start/Stop Switch (78) against the surfaces of the Thermal Volume Controller (77) protective cover by hand.
4. Place the [Hand (Jog)/Off/Auto] switch to [Auto]. The Motor (69)/Hydraulic Pump (67) should start. If the Motor (69)/Hydraulic Pump (67) does not start, adjust the Motor Start/Stop Switch (78) and target accordingly.
5. With the Motor Start/Stop Switch (78) and target properly set, and the Motor (69)/Hydraulic Pump (67) running, close the System Bypass Hand Valve (71).
6. Allow the system to fully charge with hydraulic fluid. When the Accumulator (76) is full the Thermal Volume Controller (77) will fill with fluid and the target will move off of the switch. Verify the motor/pump stops.
7. Using an open end wrench, tighten the hex nuts to secure the target to the threaded rod and threaded rod to the Thermal Volume Controller (77) rod. Tighten the jam nuts of the Motor Start/Stop Switch (78) against the surfaces of the Thermal Volume Controller (77) protective cover.

If the Motor (69)/Hydraulic Pump (67) does not stop, place the [Hand (Jog)/Off/Auto] switch to [Off] and repeat steps 2 through 7. Repeatedly cycle the system by opening the System Bypass Hand Valve (71). This will cause fluid within the Thermal Volume Controller (77) to return to the hydraulic reservoir and start the motor/pump. The entire amount of fluid within the Thermal Volume Controller (77) and Accumulator (76) does not need to be emptied, just enough to start the motor/pump and verify the switch setting is correct.

## 6.5 Recommended Annual Inspection

It is recommended the following components and features of the ECAT to be evaluated at least once a year.

- Check hydraulic fluid levels
- Check the pressure gauges
- Check bolts and fittings for tightness
- Check for external oil leaks
- Check the pneumatic fittings with a leak detection product, such as Snoop Liquid Leak Detector from Swagelok or comparable.
- Check hand pump operation functions properly
- If/When possible, perform a function test (See Section 4.6 for instructions on how to perform a function test)
- Check accumulator and thermal volume controller function
- Check the breather on the hydraulic reservoir
- Check the return filter, if included

Qualified service personnel are available upon request. Please feel free to contact:

### **EMERSON'S ACTUATION TECHNOLOGIES**

Address: 2500 PARK AVENUE WEST ONTARIO, OH 44906  
Telephone: (419) 529-4311  
Fax: (419) 529-3688

*This page is intentionally left blank.*

[www.emerson.com/shafer](http://www.emerson.com/shafer)

VCIOM-16422-EN (PC-20182) © 2024 Emerson. All rights reserved.

The Emerson logo is a trademark and service mark of Emerson Electric Co. Shafer™ is a mark of one of the Emerson family of companies. All other marks are property of their respective owners.

The contents of this publication are presented for informational purposes only, and while every effort has been made to ensure their accuracy, they are not to be construed as warranties or guarantees, express or implied, regarding the products or services described herein or their use or applicability. All sales are governed by our terms and conditions, which are available upon request. We reserve the right to modify or improve the designs or specifications of such products at any time without notice.

**SHAFER™**

