

Rosemount™ OCX8800A

Oxygen and Combustibles Transmitter



Essential instructions

Read this page before proceeding!

Emerson designs, manufactures, and tests its products to meet many national and international standards. Because these instruments are sophisticated technical products, you must properly install, use, and maintain them to ensure they continue to operate within their normal specifications. Failure to follow the proper instructions may cause any one of the following situations to occur: loss of life, personal injury, property damage, damage to this instrument, and warranty invalidation.

- Read all instructions prior to installing, operating, and servicing the product.
- If you do not understand any of the instructions, contact your Emerson representative for clarification.
- Follow all warnings, cautions, and instructions marked on and supplied with the product.
- Inform and educate your personnel in the proper installation, operation, and maintenance of the product.
- Install equipment as specified in the installation instructions of the appropriate Quick Start Guide and per applicable local and national codes. Connect all products to the proper electrical and pressure sources.
- To ensure proper performance, use qualified personnel to install, operate, update, program, and maintain the product.
- When replacement parts are required, ensure that qualified people use replacement parts specified by Emerson. Unauthorized parts and procedures can affect the product's performance, place the safe operation of your process at risk, and VOID YOUR WARRANTY. Look-alike substitutions may result in fire, electrical hazards, or improper operation.
- Ensure that all equipment doors are closed and protective covers are in place, except when maintenance is being performed by qualified people, to prevent electrical shock and personal injury.

NOTICE

The information contained in this document is subject to change without notice.

NOTICE

If a Field Communicator is used with this unit, the software within the Field Communicator may require modification. If a software modification is required, please contact your local Emerson Service Group or National Response Center at 1-800-654-7768.

⚠ WARNING

Physical access

Unauthorized personnel may potentially cause significant damage to and/or misconfiguration of end users' equipment. This could be intentional or unintentional and needs to be protected against.

Physical security is an important part of any security program and fundamental in protecting your system. Restrict physical access by unauthorized personnel to protect end users' assets. This is true for all systems used within the facility.

Preface

The purpose of this manual is to provide a comprehensive understanding of the Rosemount OCX8800 components, functions, installation, and maintenance.

Emerson recommends that you thoroughly familiarize yourself with [Description and specifications](#) and [Install](#) before installing your transmitter.

[Description and specifications](#) presents the basic principles of the transmitter along with its performance characteristics and components. The remaining sections contain detailed procedures and information necessary to install and service the transmitter.

Before contacting Emerson concerning any questions, first consult this manual. It describes most situations encountered in your equipment's operation and details necessary action.

Definitions

The following definitions apply to warnings, cautions, and notes found throughout this publication.

WARNING

Highlights an operation or maintenance procedure, condition, statement, etc. that if not strictly observed, could result in injury, death, or long-term health hazards of personnel.





CAUTION

Highlights an operation or maintenance procedure, practice, condition, statement, etc. that if not strictly observed, could result in damage to or destruction of equipment or loss of effectiveness.

Note

Highlights an essential operating procedure, condition, or statement.

Symbols

	Earth (ground) terminal
	Protective conductor terminal
	Risk of electrical shock
	Warning: Refer to Reference Manual.

Notice

The contents of this publication are presented for informational purposes only, and while every effort has been made to ensure their accuracy, they are not to be construed as warranties or guarantees, expressed or implied, regarding the products or services described herein or their use or applicability. All sales are governed by Rosemount's terms and conditions, which are available upon request. We reserve the right to modify or improve the designs or specifications of such products at any time.

Rosemount does not assume responsibility for the selection, use, or maintenance of any product. Responsibility for proper selection, use, and maintenance of any Rosemount product remains solely with the purchaser and end-user.

To the best of Rosemount's knowledge, the information herein is complete and accurate. Rosemount makes no warranties, expressed or implied, including implied warranties of merchantability and fitness for a particular purpose, with respect to this manual and, in no event, shall Rosemount be liable for any incidental, punitive, special, or consequential damages including, but not limited to, loss of production, loss of profits, loss of revenue or use, and costs incurred, including without limitation for capital, fuel and power, and claims of third parties.

Product names used herein are for manufacturer or supplier identification only and may be trademarks/registered trademarks of these companies.

Rosemount and the Rosemount logo are registered trademarks of Rosemount. The Emerson logo is a trademark and service mark of Emerson Electric Co.

Contents

Chapter 1	Description and specifications.....	7
	1.1 Component checklist.....	7
	1.2 System overview.....	9
	1.3 Specifications.....	19
	1.4 Ordering information.....	22
Chapter 2	Install.....	23
	2.1 Product safety.....	23
	2.2 Mechanical installation.....	23
	2.3 Electrical installation.....	29
	2.4 Pneumatic installation.....	39
	2.5 Initial start-up.....	46
Chapter 3	Configuration and start-up.....	47
	3.1 Verify installation.....	47
	3.2 Initial power up.....	50
	3.3 Setting test gas values.....	50
	3.4 Reset.....	51
	3.5 Calibration solenoids.....	52
	3.6 Blowback feature.....	52
	3.7 Calibration verify feature.....	54
	3.8 Calibration tolerance feature.....	55
	3.9 COe purge/zero feature.....	56
Chapter 4	Using the local operator interface (LOI).....	59
	4.1 Display orientation.....	59
	4.2 Local operator interface (LOI) controls.....	60
	4.3 Local operator interface (LOI) menu tree.....	63
	4.4 D/A trim procedures.....	68
Chapter 5	Using HART® communications.....	71
	5.1 Overview.....	71
	5.2 Field Communicator signal connections.....	71
	5.3 Field Communicator PC connections.....	74
	5.4 HART® menu tree.....	75
	5.5 D/A trim procedures.....	79
Chapter 6	Calibration.....	81
	6.1 Overview.....	81
	6.2 Fully automatic calibration.....	81
	6.3 Operator-initiated autocalibration.....	83
	6.4 Manual calibration.....	83
Chapter 7	Field Communicator.....	91
	7.1 Overview.....	91
	7.2 Field Communicator connections.....	91

	7.3 Fieldbus menu tree.....	94
Chapter 8	FOUNDATION™ Fieldbus.....	99
	8.1 FOUNDATION™ Fieldbus technology.....	99
	8.2 Network communication.....	102
	8.3 Rosemount OCX8800 function blocks.....	103
	8.4 Resource block.....	104
	8.5 Configure PlantWeb alert (PWA) simulation with the Field Communicator.....	112
	8.6 Transducer block.....	113
	8.7 Transducer block enumerations.....	120
	8.8 Analog input (AI) function block.....	127
	8.9 Proportional/integral/derivative (PID) function block.....	144
	8.10 Arithmetic (ARTHM) function block.....	167
	8.11 Advanced topics.....	175
	8.12 Input selector (ISEL) function block.....	176
	8.13 Operation with Emerson DeltaV™	183
Chapter 9	Troubleshoot.....	185
	9.1 Overview.....	185
	9.2 Diagnostic alarms.....	186
	9.3 Fault isolation.....	187
	9.4 Alarm relay events.....	204
Chapter 10	Maintenance and service.....	207
	10.1 Overview.....	207
	10.2 Removal and installation.....	207
	10.3 Repair sensor housing.....	219
	10.4 Repair electronics housing.....	247
	10.5 Replace tube fittings.....	256
Chapter 11	Replacement parts.....	259
	11.1 Sensor housing.....	259
	11.2 Electronics housing.....	263
	11.3 O ₂ cell and heater strut assembly.....	267
Appendix A	Safety data.....	269
	A.1 Safety instructions.....	269
	A.2 Safety data sheet for ceramic fiber products.....	271
	A.3 General precautions for handling and storing high pressure gas cylinders.....	276
Appendix B	Product certifications.....	277
Appendix C	SPA with HART® alarm.....	279
	C.1 Overview.....	279
	C.2 Description.....	279
	C.3 Install.....	281
	C.4 Setup.....	282
Appendix D	Returning material.....	289

1 Description and specifications

1.1 Component checklist

A typical Rosemount OCX8800 oxygen/combustibles transmitter package should contain the items shown in [Figure 1-1](#).

Use [Rosemount OCX8800 Oxygen and Combustibles Transmitter for general purpose locations](#) to verify your order number.

Check the model number of your Rosemount OCX8800 against the transmitter features and options, making sure options specified by this number are on or included with the unit. Use this complete model number for any correspondence with Emerson.

[Optional accessories](#) provides a list of accessories for use with the Rosemount OCX8800.

Figure 1-1: Typical System Package

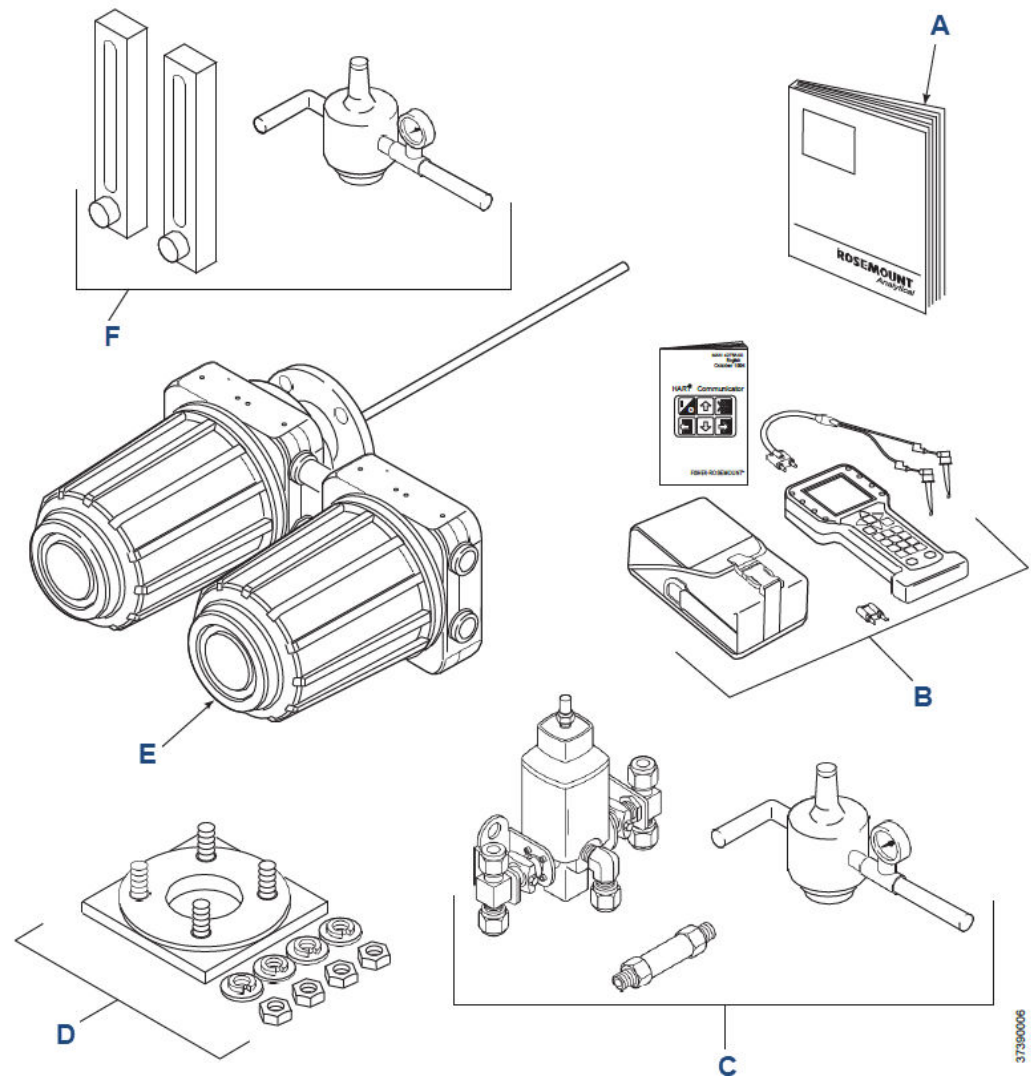

- A. Quick Start Guide
- B. Field Communicator package (optional)
- C. Blowback hardware (optional)
- D. Adapter plate with mounting hardware and gasket
- E. Rosemount OCX8800
- F. Reference air and calibration set

1.2 System overview

1.2.1 Scope

This Reference Manual supplies details needed to install, start up, operate, and maintain the Rosemount OCX8800.

Signal conditioning electronics outputs separate 4-20 mA signals representing oxygen (O₂) and combustibles (COe) values. You can access this information, plus additional details, with the HART® Field Communicator or Emerson AMS software. The local operator interface (LOI) also provides a communications interface with the electronics.

1.2.2 System description

Emerson has designed the Rosemount OCX8800 to measure oxygen and combustible concentrations in flue gas temperatures up to 2600 °F (1427 °C). Electrical connections, power, and communications are made through two ¾ national pipe thread (NPT) ports in the flameproof electronics enclosure using fittings and cables provided by the customer. Cable installation must meet NEC, IEC, and/or other applicable national or local codes for Class I, Zone 1, Group IIB +H2 T3/T6 permanently mounted equipment. The transmitter is close coupled to the process and requires minimum sample conditioning requirements.

The equipment measures oxygen percentage by reading the voltage developed across a heated electrochemical cell, which consists of a small yttria-stabilized, zirconia disc. Both sides of the disc are coated with porous metal electrodes. When operating at the proper temperature, the following Nernst equation gives the millivolt output of the cell.

$$EMF = KT \log_{10} (P_1/P_2) + C$$

where:

1. P₂ is the partial pressure of the oxygen in the measured gas on one side of the cell.
2. P₁ is the partial pressure of the oxygen in the reference air on the opposite side of the cell.
3. T is the absolute temperature.
4. C is the cell constant.
5. K is an arithmetic constant.

Note

For best results, use clean, dry instrument air (20.95 percent oxygen) as the reference air.

When the cell is at operating temperature and there are unequal oxygen concentrations across the cell, oxygen ions travel from the high oxygen partial pressure side to the low oxygen partial pressure side of the cell. The resulting logarithmic output voltage is approximately 50 mV per decade. The output is proportional to the inverse logarithm of the oxygen concentration. Therefore, the output signal increases as the oxygen concentration of the sample decreases. This characteristic enables the transmitter to provide exceptional sensitivity at low oxygen concentrations.

The Rosemount OCX8800 oxygen sensor measures net oxygen concentration in the presence of all the products of combustion, including water vapor. Therefore, it may be considered an analysis on a **wet** basis. In comparison with older methods, such as the portable apparatus, which provides an analysis on a **dry** gas basis, the **wet** analysis will, in general, indicate a lower percentage of oxygen. The difference will be proportional to the water content of the sampled gas stream.

The combustibles sensor is a catalytic sensor consisting of two resistance temperature devices (RTDs). One RTD is the reference element covered with an inert coating. The other RTD element is active, coated with a catalyst. As the sample gases flow by the sensor, the combustible gases oxidize on the surface of the active element. The oxidation that occurs produces heat and a temperature rise in the active element. The temperature difference produces a resistance relationship between the two elements that is directly proportional to the concentration of combustibles in the sample gases.

The catalyst is specifically designed to detect carbon monoxide (CO), but the sensor responds to other combustible gases. The sensor is calibrated using CO; thus the output should be expressed in terms of CO. However, as the sensor detects other combustible gases, the output cannot just be labeled CO. The response of the sensor to other combustible gases gives an output that is equivalent to the sensor detecting CO.

The term COe is used in this Manual to describe the sensor output. This term indicates that the sensor is calibrated in terms of CO and that the sensor output is equivalent to CO but not specific to CO.

Dilution air is provided to the COe sensor to ensure that there is adequate oxygen to fully oxidize any combustible gases regardless of the concentration of oxygen in the process.

1.2.3 System configurations

Transmitters are available in four lengths, giving you the flexibility to use a penetration appropriate to the size of the stack or duct. The length options are 18 in. (457 mm), 3 ft. (0.91 m), 6 ft. (1.83 m), or 9 ft. (2.7 m). Probes are available in three material options: 316L stainless steel, Inconel 600, and ceramic to accommodate higher temperatures.

The electronics are contained in a separate housing from the sensors. When the transmitter is configured with the integral electronics option, the electronics and sensor housings are mounted as a unit at the stack mounting flange. When the transmitter is configured with the remote electronics option, the electronics housing is separated from the sensor housing. The electronics housing may be mounted up to 150 ft. (45.7 m) from the sensor housing.

The electronics control both sensor temperatures and provide output signals in one of two ways:

1. Individual 4-20 mA isolated outputs that are proportional to the measured oxygen and combustibles concentrations. The oxygen output also contains HART® communication.
2. Single FOUNDATION™ Fieldbus output.

The electronics control both sensor temperatures and provide individual 4-20 mA isolated outputs that are proportional to the measured oxygen and combustibles concentrations. The power supply can accept voltages of 100 to 240 Vac and 50 to 60 Hz. The electronics accepts millivolt signals generated by the sensors and produces the outputs to be used by remotely connected devices. The outputs are isolated 4-20 mA linearized currents. Refer to [Configuration and start-up](#) for specific instructions upon initial power up.

1.2.4 System features

1. The O₂ cell output voltage and sensitivity increase as the oxygen concentration decreases.
2. HART® communication is standard. To use this capability, you must have either:
 - a. Field Communicator
 - b. Asset Management Solutions (AMS) software for the PC

3. Oxygen cell and heater/thermocouple assembly are field replaceable.
4. Electronics are automatically configured for line voltages from 100 to 240 Vac.
5. An operator can calibrate and diagnostically troubleshoot the transmitter in one of two ways:
 - a. Local operator interface (LOI): The LOI is mounted to the end of the electronics module and allows local communications with the electronics. Refer to [Using the local operator interface \(LOI\)](#) for more information.
 - b. Optional HART interface. Each of the transmitter's 4-20 mA output lines transmits an analog signal proportional to oxygen or combustible levels detected. The HART output is superimposed on the oxygen 4-20 mA output line only. This information can be accessed through the following:
 - Field Communicator: The handheld Field Communicator requires Device Description (DD) software specific to the Rosemount OCX8800. The DD software is supplied with many Field Communicators, but can also be programmed into existing Field Communicators at most Emerson service offices. Refer to [Using HART® communications](#) for additional information.
 - Personal computer (PC): The use of a personal computer requires AMS software available from Emerson.
 - Selected distributed control systems: The use of distributed control systems requires input/output (I/O) hardware and AMS software which permit HART communications.
6. When the transmitter is configured without the LOI, you must calibrate and diagnostically troubleshoot the transmitter using the HART or FOUNDATION Fieldbus interface.
7. Optional blowback system: The blowback system periodically blows instrument air back through the sample line filter and out the sample tube. This clears out particulate and keeps the sample line filter from clogging.

1.2.5 System operation

The sensor housing and probe mount to a duct or process wall so that the probe protrudes into the flue gas stream. An air powered eductor continuously pulls samples of the process flue gas through the probe to a chamber in front of the sensor housing where the sample passes the O₂ sensor and continues on the COe sensor. Dilution air is provided to the COe sensor and reference air to the O₂ sensor. After the gas sample flows past the O₂ sensor and through the COe sensor, it is drawn through the eductor where it mixes with the eductor air and exits through exhaust back into the system.

The electronics housing contains the CPU and communication boards, which convert the sensor inputs into 4-20 mA analog output signals. The CPU can also initiate and perform calibrations. Solenoids can turn on and off three test gases and instrument air. A flow meter between the electronics and sensor housings regulates test gas flow to the sensors. Instrument air is separated into eductor air, reference air, and dilution air. The instrument air solenoid does not allow air flow until the heaters are up to temperature. This minimizes the amount of sampled process flue gas being pulled into the cold sensors causing condensation.

Figure 1-2: System Operation Diagram

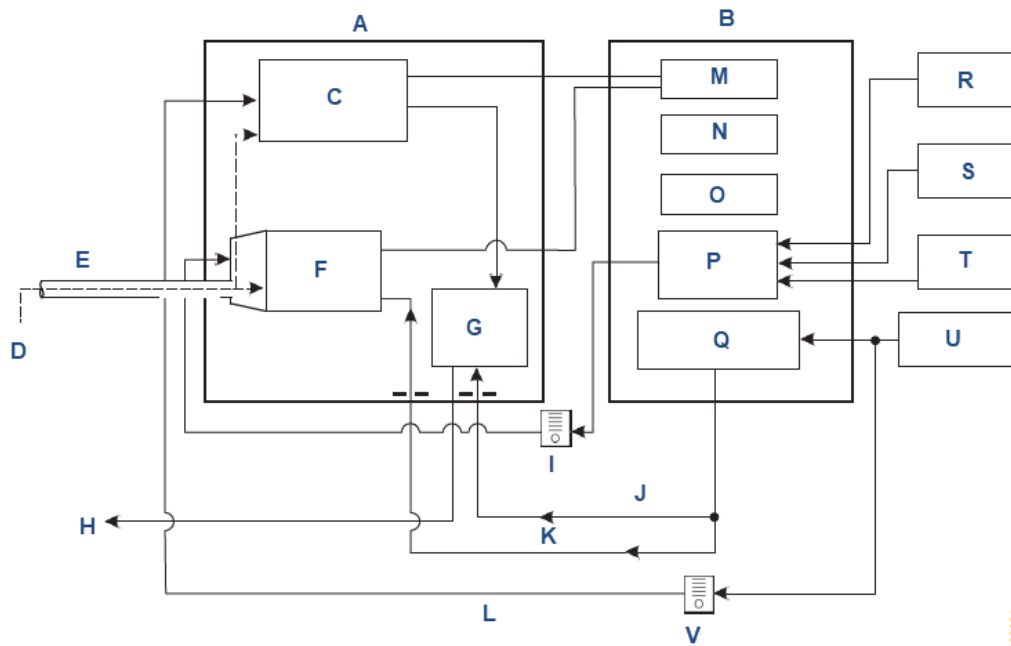

- A. Sensor housing
- B. Electronics housing
- C. COe combustibles sensor
- D. Sample gas
- E. Probe
- F. O₂ sensor
- G. Eductor
- H. Exhaust
- I. Flow meter 7 scfh
- J. Eductor air
- K. Reference air
- L. Dilution air
- M. CPU
- N. HART® board
- O. Power supply
- P. Optional test gas solenoids
- Q. Instrument air solenoid
- R. Low O₂ test gas
- S. High O₂ test gas
- T. CO test gas
- U. Instrument air
- V. Flow meter 50 cc/min. (0.1 scfh)

37196001

1.2.6 Handling the transmitter

⚠ CAUTION

Equipment damage

The Rosemount OCX8800 is designed for industrial applications. The probe may contain components made from ceramics, which are susceptible to shock when mishandled.

Treat each component of the system with care to avoid physical damage.

Only handle printed circuit boards and integrated circuits when adequate anti-static precautions have been taken to prevent possible equipment damage.

1.2.7 System considerations

Prior to installing your transmitter, make sure you have all the components necessary to make the system installation. Ensure that all components are properly integrated to make the system functional.

After verifying that you have all the components, select mounting locations and determine how each component will be placed in terms of available line voltage, ambient temperatures, environmental considerations, convenience and serviceability. [Figure 1-4](#) shows a typical system wiring for a system with integral electronics. [Figure 1-5](#) shows a typical system wiring for a system with remote electronics. [Figure 1-6](#) shows the dimensions for the optional sample tube support.

[Figure 1-7](#) shows the dimensions for the optional in-situ filters. [Figure 1-8](#) shows the optional panel mounted blowback.

A source of instrument air is required at the transmitter for reference air, dilution air, and eductor air. As the transmitter is equipped with an in-place calibration feature, make provisions for connecting test gas tanks to the transmitter when calibrating it.

Note

The electronics module is designed to meet Type 4X and IP66, and the electronic components are rated to temperatures up to 185 °F (85 °C). Retain packaging in which the transmitter arrived from the factory in case any components are to be shipped to another site. This packaging has been designed to protect the product.

Figure 1-3: Rosemount OCX8800 HART® Connections and AMS Application

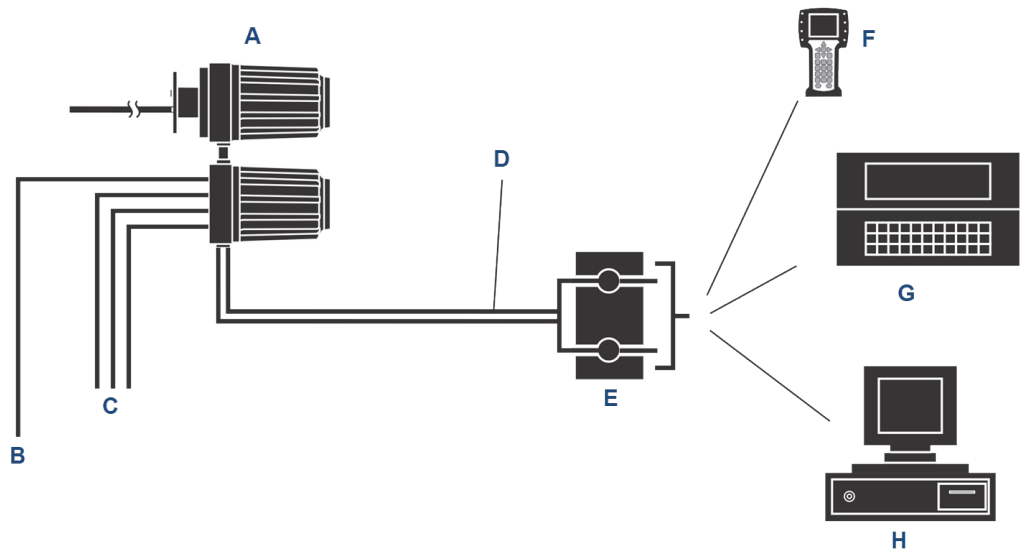

- A. Rosemount OCX8800 with integral electronics
- B. Instrument air
- C. Three calibration lines by customer (300 ft. [91 m] maximum)
- D. Signal output (twisted pairs)
- E. Termination in control room
- F. Field Communicator
- G. Customer's laptop with AMS
- H. AMS

Figure 1-4: Typical System Installation - Integral Electronics

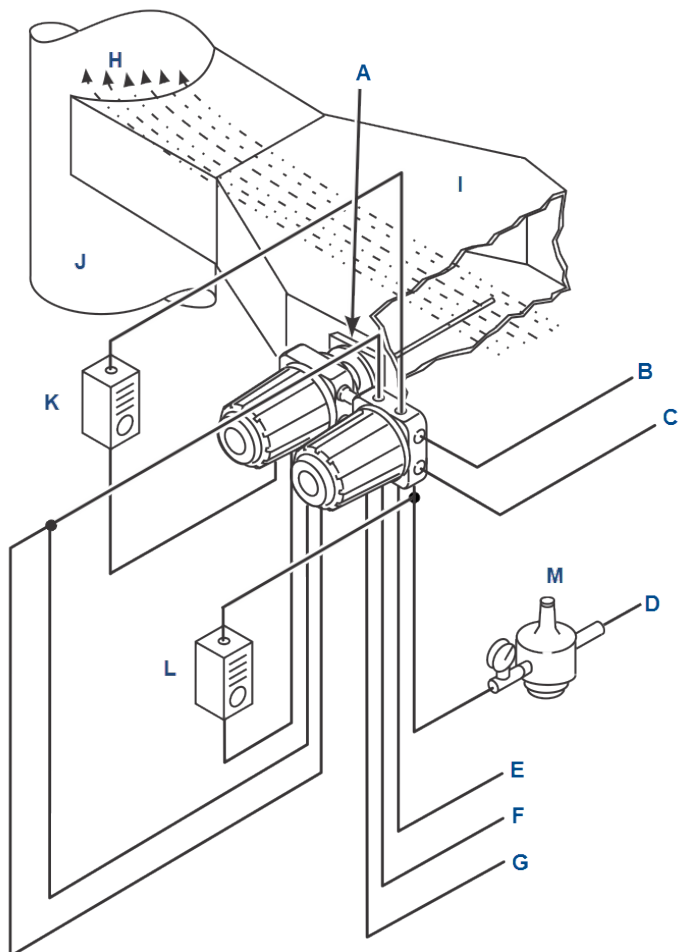

- A. Adapter plate
- B. Signal outputs (twisted pairs)
- C. Line voltage
- D. Instrument air supply (reference gas)
- E. High O₂ test gas
- F. Low O₂ test gas
- G. CO test gas
- H. Gases
- I. Duct
- J. Stack
- K. Test gas flow meter
- L. Dilution air flow meter
- M. Pressure regulator

Figure 1-5: Typical System Installation - Remote Electronics

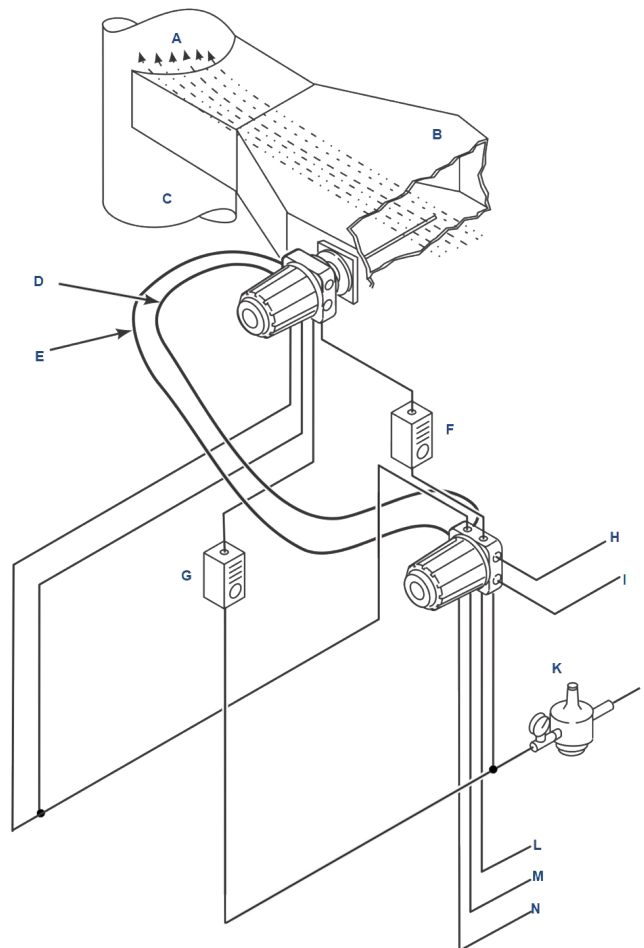

- A. Gases
- B. Duct
- C. Stack
- D. Heater power cable (up to 150 ft. [46 m])
- E. Signal cable (up to 150 ft. [46 m])
- F. Test gas flow meter
- G. Dilution air flow meter
- H. 4-20 mA outputs (two twisted pairs)
- I. Line voltage
- J. Instrument air supply (reference gas)
- K. Pressure regulator
- L. High O₂ test gas
- M. Low O₂ test gas
- N. CO test gas

Figure 1-6: Optional Sample Tube Support

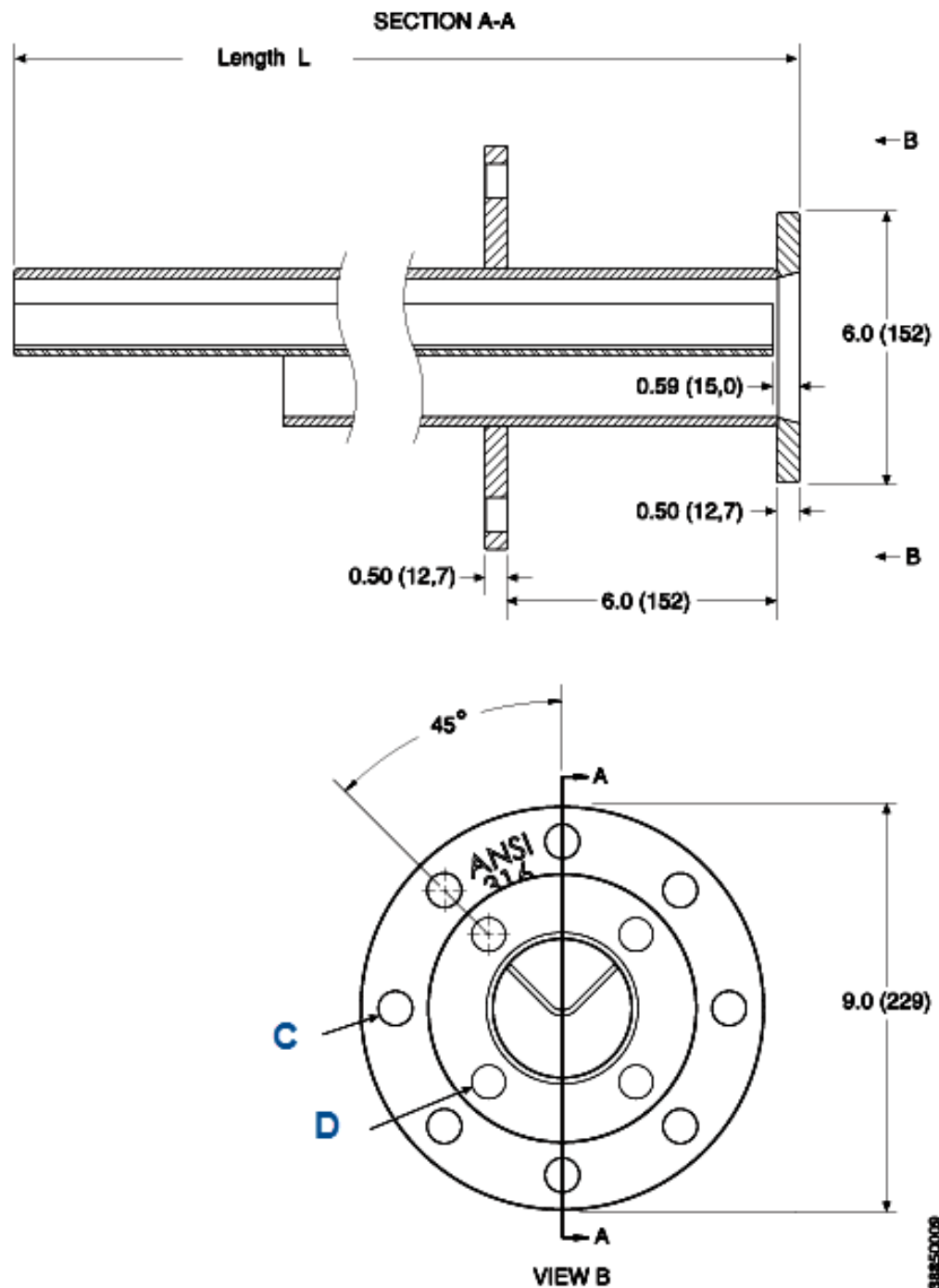

- C. 0.75-in. (19 mm) diameter on 7.5-in. (190 mm) diameter B.C., eight places
- D. 0.75-in. (19 mm) diameter on 4.75-in. (121 mm) diameter B.C., four places

Probe length in in. (mm)	Length L in in. (mm)
18 in. (457.2 mm)	24.5 (621)
3 ft. (0.9 m)	42.5 (1078)
6 ft. (1.8 m)	78.5 (1993)
9 ft. (2.7 m)	114.5 (2907)

Figure 1-7: Optional In-Situ Filters

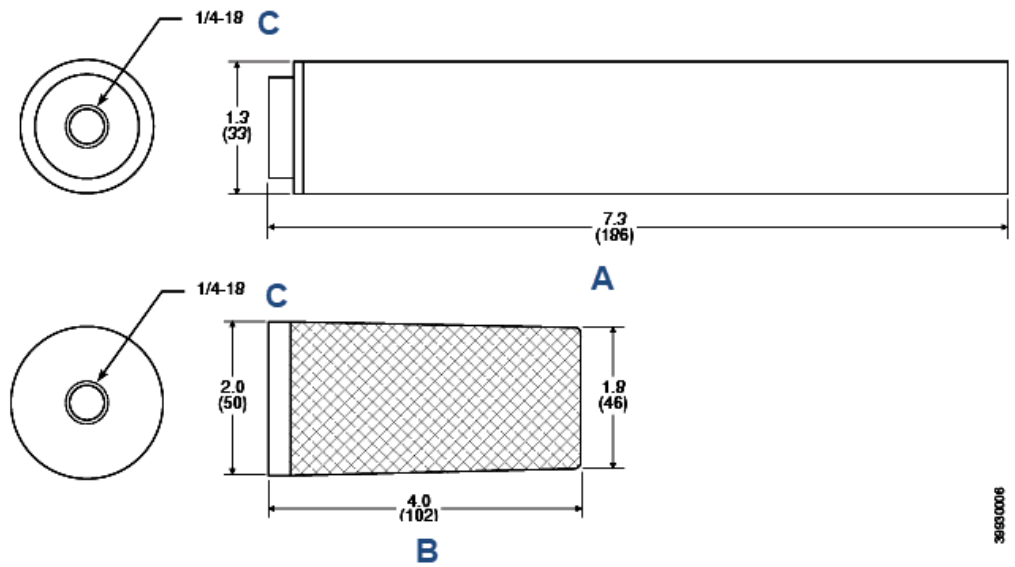

- A. In-situ stainless steel or Hastelloy filter
- B. In-situ high surface area stainless steel filter

Figure 1-8: Optional Panel Mounted Blowback and Calibration/Reference Air Set (19-in. [482.6 mm] Rack or Wall Mount)

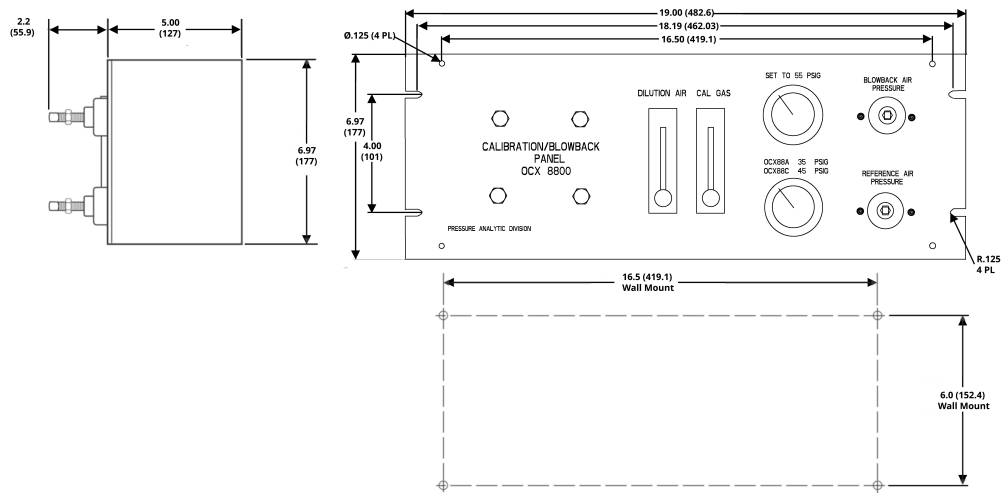

1.3 Specifications

Note

All static performance characteristics are with operating variables constant. Specifications subject to change without notice.

1.3.1 Net O₂ range

0-1 percent to 0-40 percent O₂, fully field selectable

1.3.2 Combustibles

0-1000 ppm to 0-5 percent, fully field selectable

1.3.3 Accuracy

Oxygen

±0.75 percent of reading or 0.5 percent O₂ (whichever is greater)

Combustibles

±50 ppm

1.3.4 System response to test gas

Oxygen

10 seconds T90

Combustibles

25 seconds T90

1.3.5 Temperature limits

Process

32 to 2600 °F (0 to 1427 °C)

Sensors housing

-40 to 212 °F (-40 to 100 °C) ambient

Electronics housing

-40 to 149 °F (-40 to 65 °C), ambient

-40 to 185 °F (-40 to 85 °C), internal operating temperature of electronics inside housing, as read by HART® or FOUNDATION™ Fieldbus.

Local operator interface

-40 to 158 °F (-40 to 70 °C), ambient

At temperatures above 158 °F (70 °C) inside instrument housing, the infrared keypad will cease to function, but the Rosemount OCX8800 will continue to operate properly.

1.3.6 Nominal and approximate shipping weights

18-in. (457 mm) probe package

54 lb. (20 kg)

3-ft (0.91 m) probe package

55 lb. (20.5 kg)

6-ft (1.83 m) probe package

57 lb. (21 kg)

9-ft (2.74 m) probe package

59 lb. (22 kg)

1.3.7 Housings mounting

Integral electronics

Flange

Remote electronics

Sensors housing: flange

Electronics housing: wall/pipe

1.3.8 Materials

Probes

316L stainless steel: 1300 °F (704 °C)

Inconel 600: 1832 °F (1000 °C)

Ceramic: 2600 °F (1427 °C)

Enclosures

Low copper aluminum

1.3.9 Calibration

Semi-automatic or automatic

1.3.10 Calibration gas mixtures recommended (reference test gas bottles kit #1A9919G04)

0.4 percent O₂, balance N₂

8 percent O₂, balance N₂

1000 ppm CO, balance air

1.3.11 Calibration gas flow

7 scfh (3.3 L/m), regulated to 20 to 30 psig (1.38 to 2.07 barg)

1.3.12 Reference air

2 scfh (1 L/m), clean, dry, instrument-quality air (20.95 percent O₂), regulated to 35 psig (2.41 barg)

1.3.13 Eductor air

5 scfh (2.5 L/m), clean, dry, instrument-quality air (20.95 percent O₂), regulated to 35 psig (2.4 barg)

1.3.14 Dilution air

0.1 scfh (0.05 L/m), clean, dry, instrument-quality air (20.95 percent O₂), regulated to 35 psig (2.41 barg)

1.3.15 Blowback air (optional)

Clean, dry, instrument-quality air (20.95 percent O₂), regulated to ≥ 60 psig (413 kPa) or greater and ambient temperature of ≥ 0 °F (-18 °C)

1.3.16 Sensors housing

Type 4X, IP66 with fitting and pipe on reference exhaust port to clean, dry atmosphere, two ¾-14 national pipe thread (NPT) conduit ports (when reference air vents are routed to a dry area).

1.3.17 Electronics housing

Type 4X, IP66 with fitting and pipe on reference exhaust port to clean, dry atmosphere, two ¾-14 NPT conduit ports (when reference air vents are routed to a dry area).

1.3.18 Electrical noise

EN 61326-01, Class A

1.3.19 Line voltage

Universal 100 to 240 Vac ±10 percent, 50 to 60 Hz, no switches or jumpers required, ¾-14 national pipe thread (NPT) conduit port

1.3.20 Pollution degree

2

1.3.21 Over voltage category

II

1.3.22 Relative humidity

5 to 95 percent (non-condensing)

1.3.23 Isolated output

Oxygen

4-20 mAdc, 950 ohm maximum with HART® or FOUNDATION™ Fieldbus capability only

Combustibles

4-20 mAdc, 950 ohm maximum

1.3.24 Alarm

Alarm output relay - dry contact, form C, 30 mA, 30 Vdc capability

1.3.25 Power consumption

750 W maximum

1.4 Ordering information

For ordering information, refer to the [Rosemount OCX8800 Oxygen and Combustibles Transmitter Product Data Sheet](#).

2 Install

⚠ WARNING

Failure to follow the safety instructions could result in serious injury or death.
Before installing this equipment, read [Essential instructions](#).

⚠ WARNING

Hazardous areas

The Rosemount OCX880A can be installed in general purpose areas only.
Do not install the Rosemount OCX880A in hazardous areas.

2.1 Product safety

⚠ WARNING

Safety instructions

Failure to follow the safety instructions could result in serious injury or death.

⚠ WARNING

Electrical shock

Failure to install covers and ground leads could result in serious injury or death.

Install all protective equipment covers and ground leads after installation.
If external loop power is used, the power supply must be a safety extra low voltage (SELV) type.

Note

Plug all unused ports on the probe housing and Rosemount Xi enclosure with a suitable filling.

2.2 Mechanical installation

2.2.1 Select a location

The location of the transmitter in the stack or flue is important for maximum accuracy in the oxygen analyzing process. You must position the probe so the gas it measures is representative of the process.

For best results, position the transmitter near the center of the duct (40 to 60 percent insertion). Longer ducts may require several transmitters since the oxygen and combustibles can vary due to stratification. A point too near the wall of the duct or the inside radius of a bend may not provide a representative sample because of the very low flow conditions. Select the sensing point so the process gas temperature falls within the range of probe material used.

⚠ CAUTION

Damage to the electronics may result.

Do not allow the temperature of the electronics housing to exceed 185 °F (85 °C).

⚠ CAUTION

Failure to connect the pneumatic lines can allow the flow of contaminants into the transmitter's ports.

Whenever a positive stack pressure exists at the installation site, be sure to connect all pneumatic lines prior to installing the transmitter in the stack or ductwork.

Procedure

1. Check the flue or stack for holes and air leakage.
The presence of this condition will substantially affect the accuracy of the oxygen and combustibles readings. Make the necessary repairs or install the transmitter upstream of any leakage.
2. Ensure the area is clear of internal and external obstructions that will interfere with installation and maintenance access to the transmitter.
Allow adequate clearance for the removal of the transmitter.

2.2.2 Install the transmitter

Figure 2-1: Rosemount OCX8800 Installation

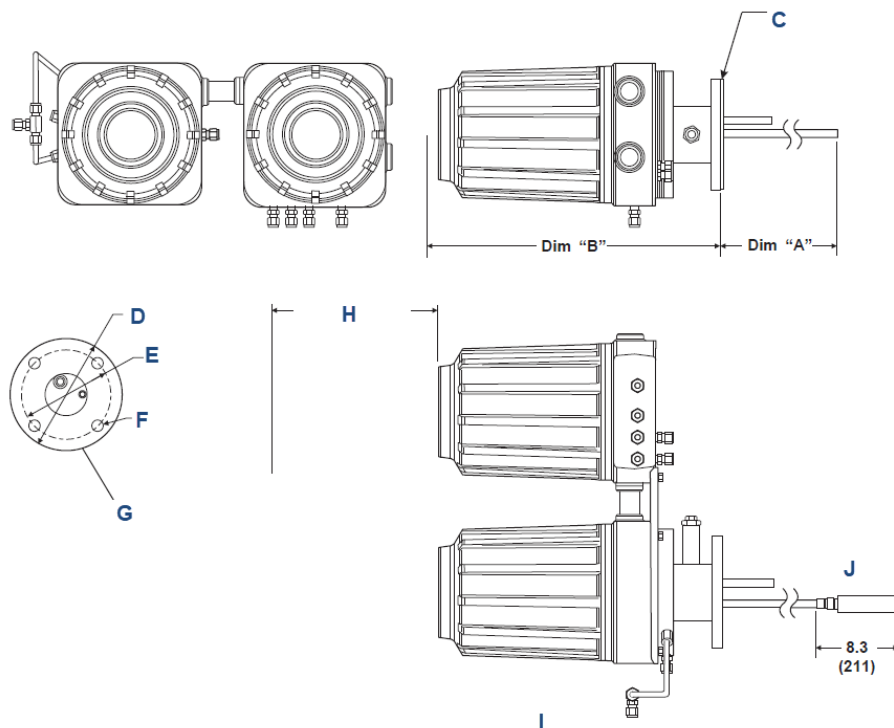

All dimensions are in inches with millimeters in parentheses.

Insulate if exposed to adverse weather or extreme temperature changes. Install a protective housing and/or insulation around the transmitter.

- A. Insertion depth (see [Table 2-3](#)).
- B. Removal envelope (see [Table 2-3](#)).
- C. See [Table 2-1](#).
- D. Flange diameter
- E. B.C. diameter
- F. Hole diameter
- G. See [Table 2-2](#).
- H. Allow 9 in. (229 mm) for cover removal.
- I. Bottom view
- J. Optional in situ filter

Table 2-1: 0.06-in. Thick Gasket

ANSI	353B18H02
DIN	353B45H01

Table 2-2: Mounting Flange

Diameter	ANSI (5R10244H01)	DIN (5R10244H02)
Flange diameter	6.00 in. (152 mm)	7.28 in. (185 mm)

Table 2-2: Mounting Flange (continued)

Diameter	ANSI (5R10244H01)	DIN (5R10244H02)
Hole diameter	0.75 in. (19 mm)	0.71 in. (18 mm)
4 holes equally spaced on B.C. diameter	4.75 in. (121 mm)	5.71 in. (145 mm)

Table 2-3: Installation/Removal

Probe	Dimension A	Dimension B
18 in. (457.2 mm)	18 in. (457 mm)	34 in. (864 mm)
3 ft. (0.9 m)	36 in. (914 mm)	52 in. (1321 mm)
6 ft. (1.8 m)	72 in. (1829 mm)	88 in. (2235 mm)
9 ft. (2.7 m)	108 in. (2743 mm)	124 in. (3150 mm)

Procedure

1. Ensure all components are available to install the transmitter.
You may install the transmitter intact as it is received.
2. Weld or bolt adapter plate onto the duct.

Figure 2-2: Adapter Plate Installation

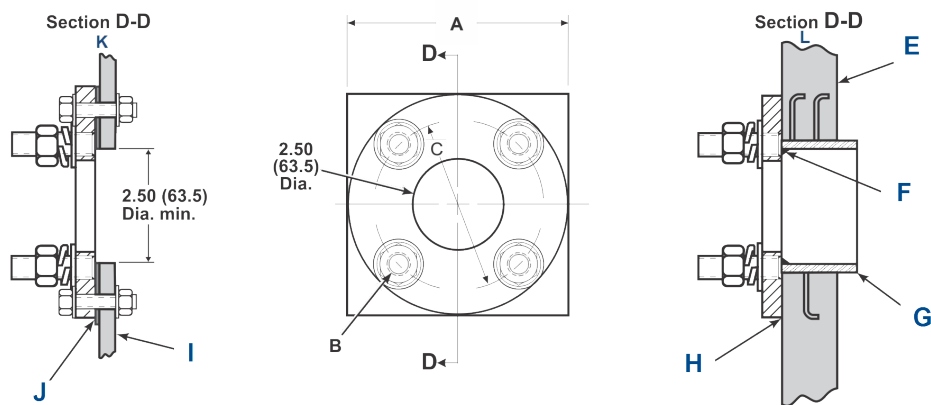

Dimensions are in inches with millimeters in parentheses. Only adapter plate is furnished by Emerson.

- A. Plate size (see [Table 2-4](#))
- B. Stud size (see [Table 2-4](#))
- C. Bolt circle diameter (see [Table 2-4](#))
- D. Cross section
- E. Masonry stack wall
- F. Field weld pipe to adapter plate
- G. Pipe 3 in. schedule 40. Sleeve length optional.
- H. Bolt adapter plate to outside wall surface. Joint must be air-tight.
- I. Metal stack or duct wall
- J. Weld or bolt adapter plate to metal wall. Joint must be air-tight.
- K. Metal wall stack or duct construction
- L. Masonry wall stack construction

Table 2-4: Adapter Plate Kit-Mounting Dimensions

Type part number ⁽¹⁾	Plate size "A"	Stud size "B"	Bolt circle diameter "C"
ANSI (PN 4512C34G01)	6.00 in. (152 mm)	5/8-11 UNC-2A	4.75 in. (121 mm)
DIN (PN 4512C36G01)	7.5 in. (191 mm)	M-16 x 2.0-6g	5.71 in. (145 mm)

(1) Part numbers for adapter plates include attaching hardware.

3. Use the pipe or wall mounting hardware to mount a remote electronics housing. Choose a location that does not exceed the length of the electronics cable ordered.
4. Ensure the conduits drop vertically from the transmitter and the conduit is routed below the level of the conduit ports on the housing to form a drip loop. Drip loops minimize the possibility that moisture will damage the electronics.

Figure 2-3: Installation with Drip Loops

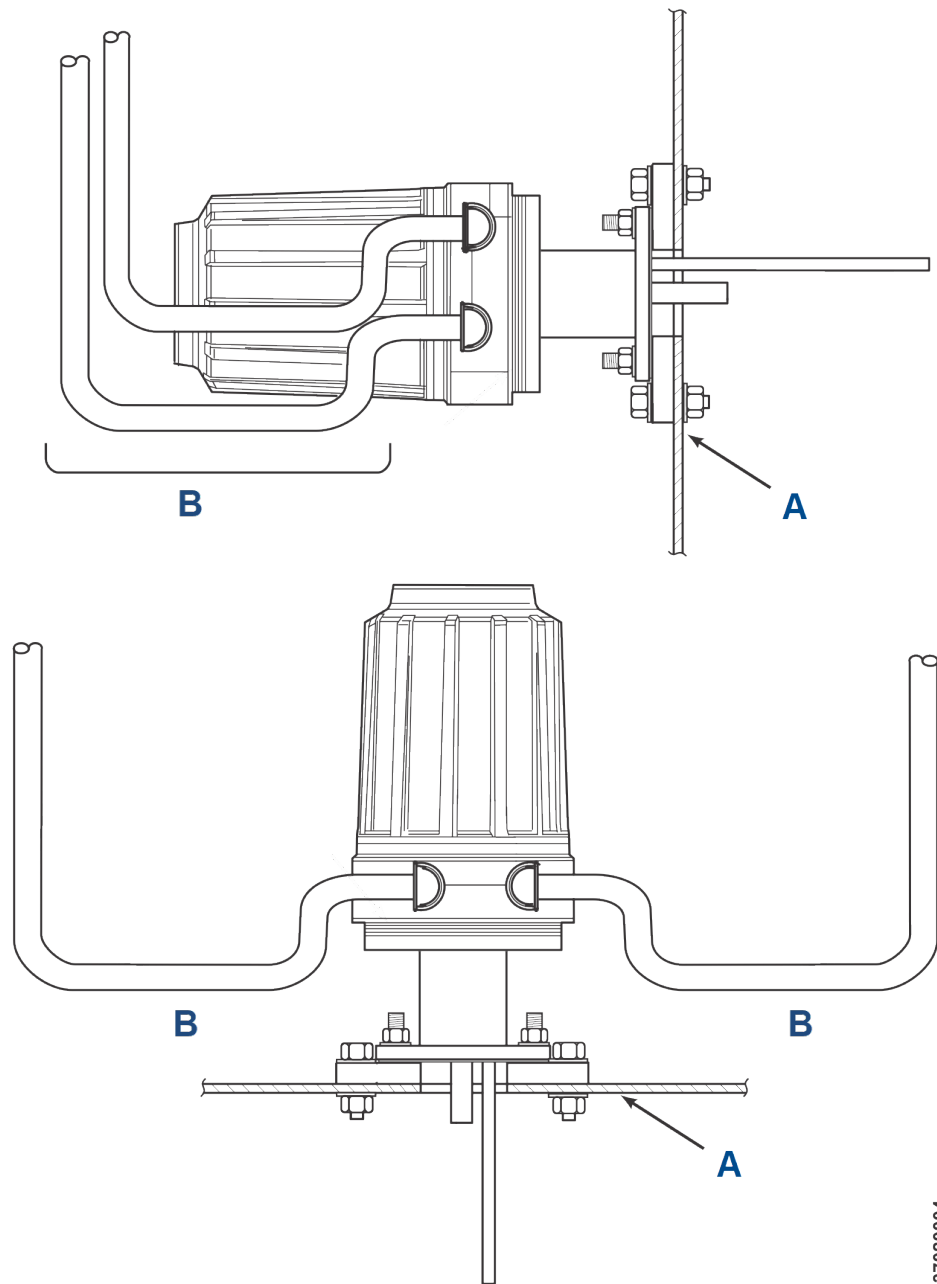

- A. Duct wall
- B. Conduit drip loops

37020004

5. Where a positive stack pressure exists at the installation site, connect all pneumatic lines prior to installing the transmitter in the stack or ductwork.

⚠ CAUTION

If process temperatures will exceed 392 °F (200 °C), use anti-seize compound on stud threads to ease future removal of the transmitter.

6. Insert sample and exhaust tubes through the opening in the mounting flange and bolt the unit to the flange.

⚠ CAUTION

Uninsulated stacks or ducts may cause ambient temperatures in the electronics housing to exceed 185 °F (85 °C) and damage the electronics.

If insulation is removed to access the duct for mounting the transmitter, make sure to replace insulation afterward.

2.2.3 Enclosures

The Rosemount OCX8800 enclosures are designed to meet ingress conditions of IP66. Each enclosure cover is threaded to its base and sealed with an O-ring that isolates the threads from external contaminants.

Each cover is secured by a clip attached to the base that engages the cover between the ribs of the cover sidewall. The clip is held in place by an Allen head cap screw and lockwasher mounted in a recess. To remove or install the cover, you will need an Allen wrench to loosen and tighten the screw.

2.3 Electrical installation

All wiring must conform to local and national codes. [Figure 2-10](#) shows factory wired solenoid power connections.

⚠ WARNING

Failure to lock out power could result in serious injury or death.

Disconnect and lock out power before connecting the transmitter to the power supply.

⚠ WARNING

Failure to install covers and ground leads could result in serious injury or death.

Install all protective equipment covers and safety ground leads after installation.

⚠ WARNING

To meet the Safety Requirements of IEC 61010 (EC requirement), and ensure safe operation of this equipment, connection to the main electrical power supply must be made through a circuit breaker (minimum 10 A) in close proximity and marked for this equipment which will disconnect all current-carrying conductors during a fault situation. This circuit breaker should also include a mechanically operated isolating switch. If not, then another external means of disconnecting the supply from the equipment should be located close by. Circuit breakers or switches must comply with a recognized standard such as IEC 947.

⚠ WARNING

The Rosemount OCX88A can be installed in general purpose areas only. Do not install it in hazardous areas.

Note

To maintain proper earth grounding, ensure a positive connection exists between the sensor housing, the electronics housing, and earth. The connecting ground wire must be 14 AWG minimum. Refer to [Figure 2-10](#).

Note

Line voltage, signal, and relay wiring must be rated for at least 221 °F (105 °C).

2.3.1 Electrical connections

Make electrical connections, power, and communications to the electronics enclosure through two ¾-in. NPT ports in the enclosure, using fittings and cables provided by the customer.

Cable installation must meet NEC, IEC, and/or other applicable national or local codes for Class I, Zone 1, IIB +H2 T3/T6 permanently mounted equipment.

2.3.2 Connect line voltage

The transmitter operates on 100 to 240 Vac line voltage at 50 to 60 Hz. The power supply requires no setup.

Connect the line (L wire) to the **L** terminal and the neutral (N wire) to the **N** terminal on the AC power input terminal block in the electronics housing. Connect the ground (G wire) to the ground stud in the electronics housing as shown in [Figure 2-10](#).

2.3.3 Connect 4-20 mA signals

Connect the 4-20 mA current loop to the 4-20 mA signal output terminals in the electronics housing as shown in [Figure 2-10](#).

Use individual shielded twisted wire pairs. Terminate the shield at the electronics housing.

2.3.4 Oxygen (O₂) 4-20 mA signal

One 4-20 mA signal represents the O₂ value.

Superimposed on the O₂ signal is the HART® information accessible through a handheld communicator or AMS Device Manager software.

The O₂ signal is at the **AOUT 1** terminals.

2.3.5 Combustibles equivalent (COe) 4-20 mA signal

Another 4-20 mA signal at the **AOUT 2** terminals represents the COe value.

HART® information is not available on the COe signal.

2.3.6 FOUNDATION™ Fieldbus signal

The FOUNDATION Fieldbus signal provides all output information and is accessible through a Handheld Communicator.

2.3.7 Alarm output relay

Connect any customer-supplied relay input to the alarm output relay terminal. Use shielded wire and terminate the shield at the electronics housing. The alarm output relay terminal is a set of dry, number 2, form C contacts with 30 mA, 30 Vdc capacity.

Figure 2-4: Alarm Output Relay Terminal Block

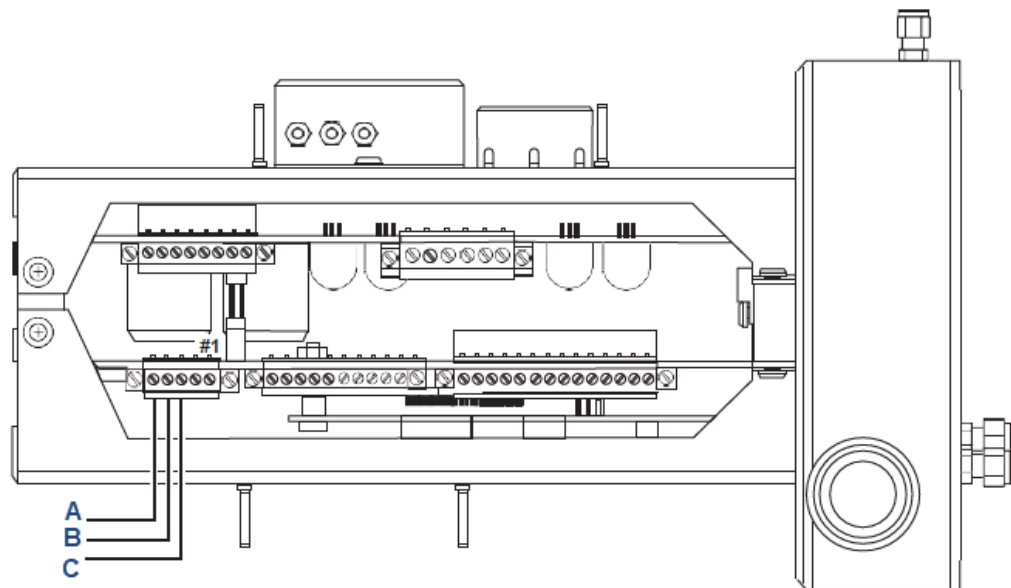

- A. Normally closed
- B. Common
- C. Normally open

Figure 2-5: 4-20 mA Signal Output Terminal Block

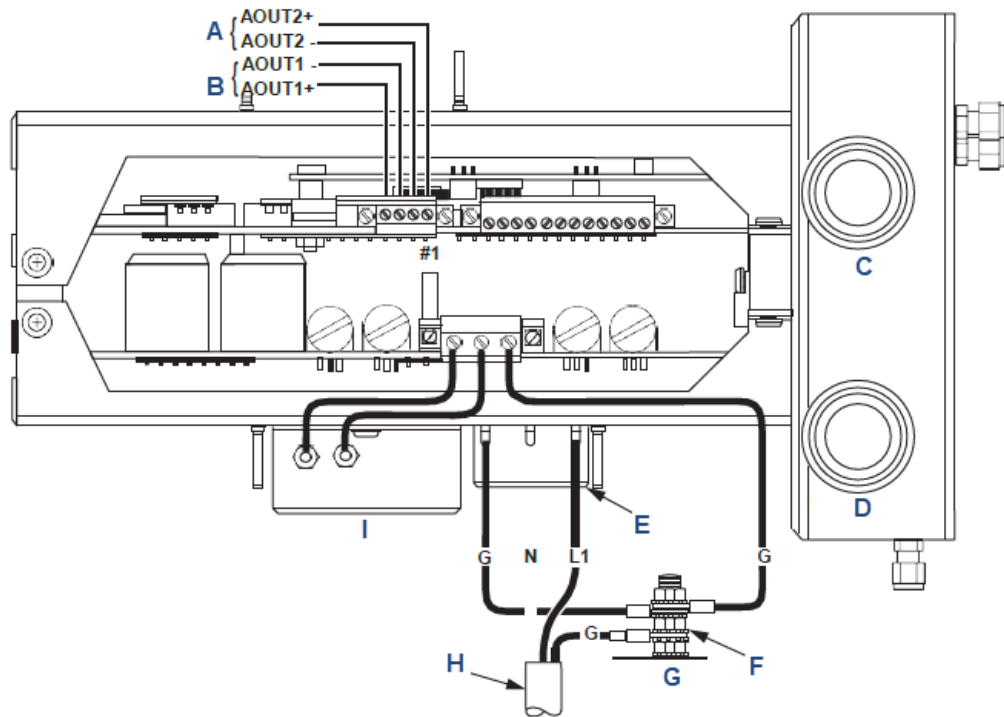

- A. CO_e signal
- B. O₂ signal
- C. Signal port $\frac{3}{4}$ national pipe thread (NPT)
- D. Power port $\frac{3}{4}$ NPT
- E. Terminal block
- F. External tooth lockwasher
- G. Ground stud
- H. Customer wiring
- I. EMI filter

Figure 2-6: Terminal Block Top View

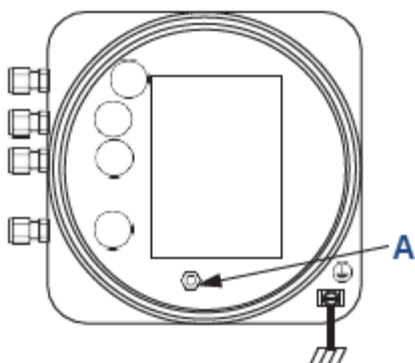

Earth ground typical for electronics and sensor housing.

A. Ground stud

2.3.8 Remote electronics connections to sensor housing

Make the following connections between the remote electronics and sensor housings with the electronics cable ordered with the package (Figure 2-7). Braided cable is available in lengths up to 150 ft (46 m).

Figure 2-7: Electrical Connections between Remote Electronics and Sensor Housing

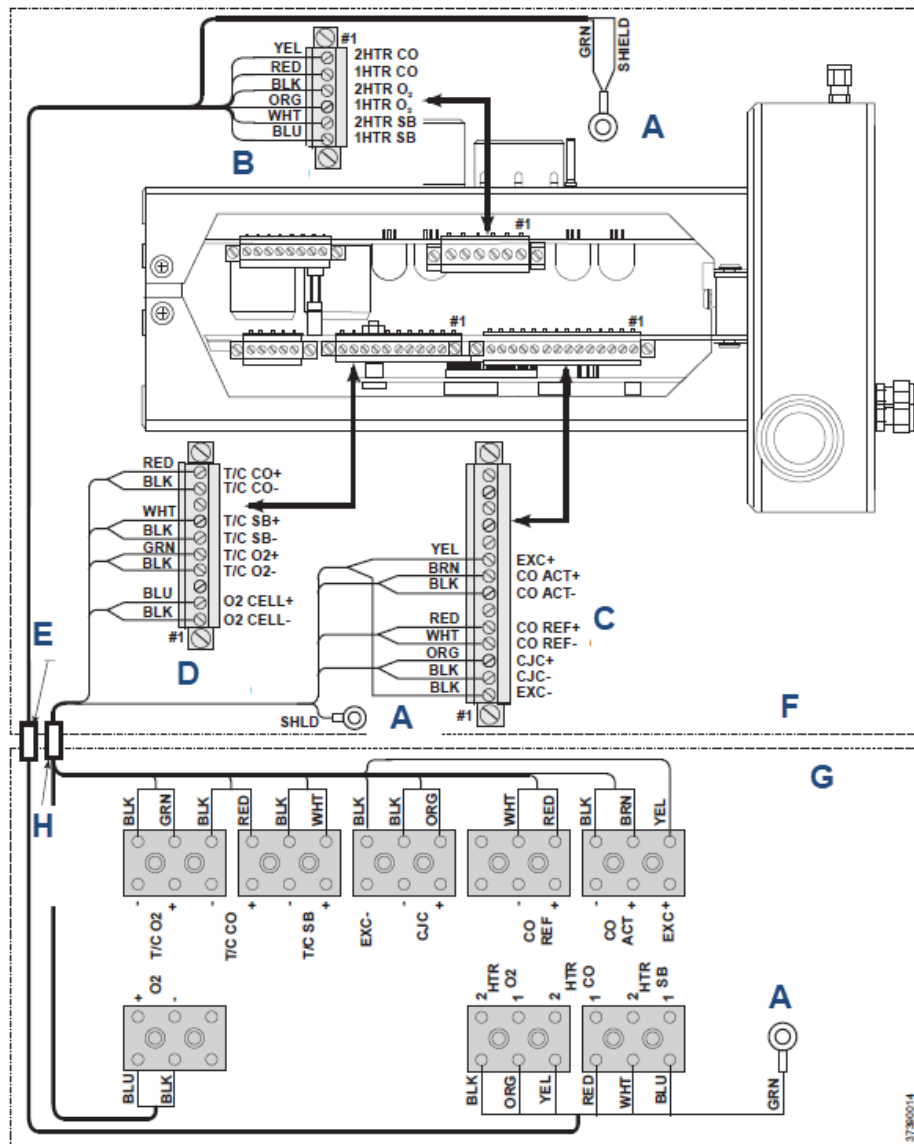

- A. To ground screw
- B. Heater power connector (J3)
- C. COe sensor and cold junction connector (J4)
- D. O₂ sensor and thermocouple connector (J5)
- E. Heater power cable
- F. Electronics housing
- G. Sensor housing
- H. Signal cable

Table 2-5: J3 Connections

Wire color	Connects to
Yellow	2 heater CO

Table 2-5: J3 Connections (continued)

Wire color	Connects to
Red	1 heater CO
Black	2 heater O ₂
Orange	1 heater O ₂
White	2 heater sample block
Blue	1 heater sample block
Green	Shield

Table 2-6: J4 Connections

Wire color	Connects to
Yellow	Execute +
Brown	CO act +
Black	CO act -
Red	CO reference +
White	CO reference =
Orange	Cold junction connector (CJC) +
Black	CJC -
Black	Execute -

Table 2-7: J5 Connections

Wire color	Connects to
Red	Thermocouple (T/C) CO +
Black	T/C CO -
White	T/C sample block (SB) +
Black	T/C SB -
Green	T/C O ₂ +
Black	T/C O ₂ -
Blue	O ₂ cell +
Black	O ₂ cell -

Note

Interconnect wiring shown is for Rosemount supplied cables. For customer furnished interconnect wiring or cables, refer to [Figure 2-8](#) and [Figure 2-9](#).

Figure 2-8: Signal Wiring or Cable

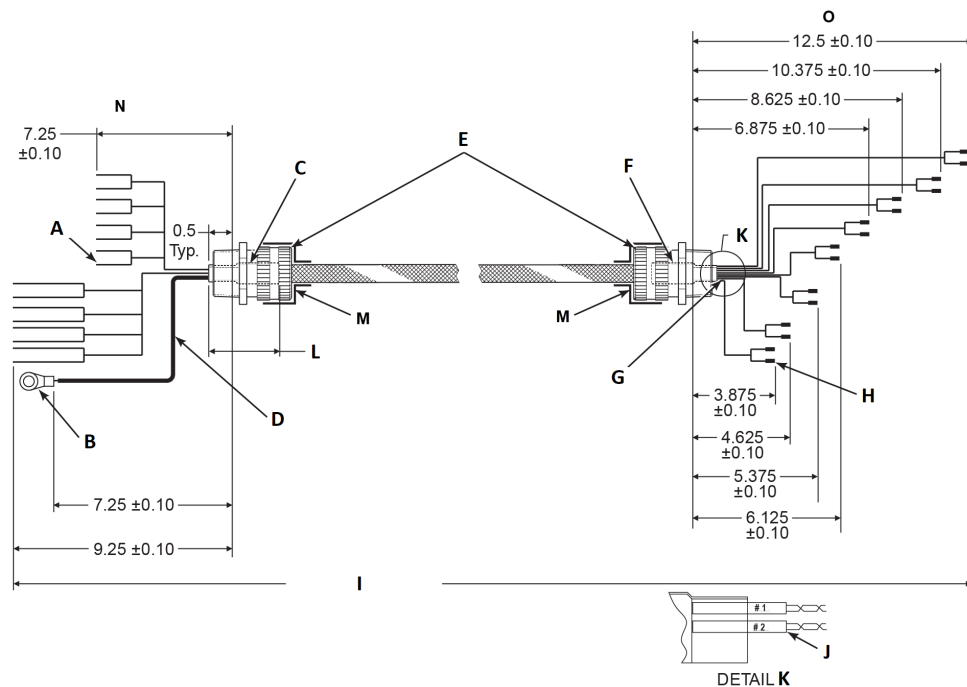

- A. Strip wire ends 3/16-in. (4.8 mm) typical
- B. Stud size #10
- C. Heat shrink tubing 2-in. (50.8 mm) long 1/2-in. (12.7 mm) size
- D. 7.0-in. (177.8 mm) long PTFE tubing, 0.042-in. ID (Cut off drain wire at probe end of shield.)
- E. 3/4 national pipe thread (NPT) hub size, liquid-tight strain relief connector
- F. Heat shrink tubing 2-in. (50.8 mm) long 1/2-in. (12.7 mm) size
- G. 8 twisted pairs 24 AWG, stranded, insulated, tinned copper conductors, 400 °F (200 °C), 300 volts, with overall braid of 34 AWG tinned copper, uninsulated drain wire
- H. Ferrule, uninsulated
- I. Overall cable length by customer 150-ft. (45.7 m) maximum
- J. Heat shrink tubing 1-in. (25.4 mm) long, 3/16-in. (4.8 mm) size
- K. Typical on both ends of wiring
- L. 2.0 ± 0.25 typical
- M. For RFI/CE compliance, the connector must provide 360 degrees of electrical contact to the cable shield.

Figure 2-9: Heater Wiring or Cable

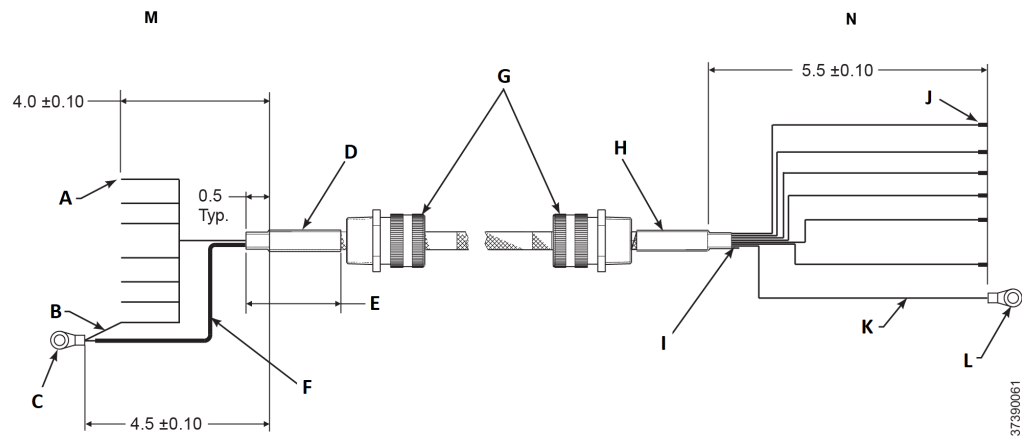

- A. Strip wire ends 3/16-in. (4.8 mm) typical
- B. Green, 16 AWG
- C. Stud size #10
- D. Heat shrink tubing 2-in. (50.8 mm) long ½-in. (12.7 mm) size
- E. 2.0 ± .25 typical
- F. 4.25-in. (108 mm) long PTFE tubing, 0.042-in. (1.1 mm) ID. (Cut off drain wire at probe end of shield).
- G. ¾ NPT hub size, liquid-tight strain relief connectors
- H. Heat shrink tubing 2-in. (50.8 mm) long ½-in. (12.7 mm) size
- I. 8 Conductors, 16 AWG, stranded, 400 °F (200 °C), 600 volts. Braided shield - tinned copper, 90% coverage with 18 AWG 24 tinned copper, uninsulated, drain wire.
- J. Ferrule, uninsulated
- K. Green, 16 AWG
- L. Stud size #6
- M. Electronics end
- N. Probe end

Note

For RFI/CE compliance, the connector must provide 360 degrees of electrical contact to the cable shield.

2.3.9 Signal connections

Connect the electronics housing terminals to the corresponding terminals in the sensor housing. The twisted wire pairs are numbered on the inner plastic wrapper.

Keep twisted pairs together and match the numbers and wire colors.

2.3.10 Heater power connections

Use the blue, white, orange, black, red, and yellow stranded wires in the heater power cable to connect power to the three heaters in the sensor housing.

Match the wire colors to the corresponding heater power terminal blocks in the sensor and electronics housings.

Figure 2-10: Line voltage, earth, and 4-20 mA connections

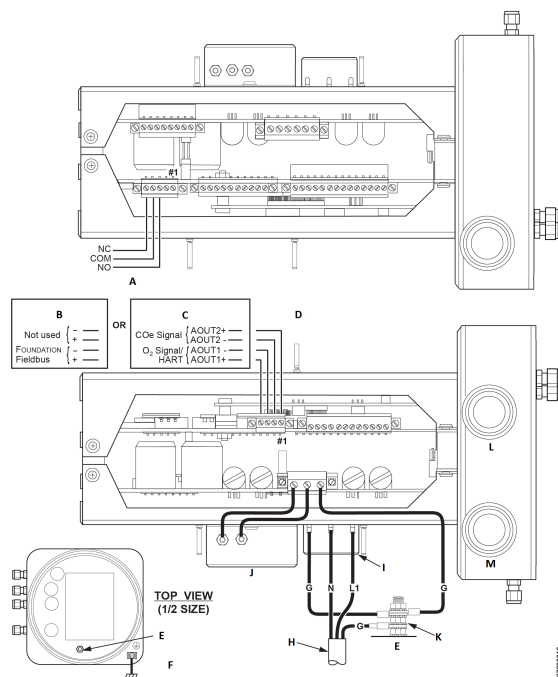

- A. Alarm output relay terminal block
- B. FOUNDATION™ Fieldbus
- C. HART®
- D. Signal output terminal block
- E. Ground stud
- F. Earth ground typical for electronics and sensor housing
- G. Ground
- H. Customer wiring
- I. Terminal block
- J. EMI filter
- K. External tooth lock washer
- L. Signal port 3/4 NPT
- M. Power port 3/4 NPT

2.4 Pneumatic installation

Pneumatic system connections depend on whether reference air set, calibration solenoids, and/or blowback equipment options are equipped on your transmitter. Refer to the following sections and select the option that applies to your transmitter configuration.

2.4.1 Reference air set option (only)

When no options or only the reference air set option is equipped, use the following procedure to install the pneumatic system components.

Procedure

1. Refer to [Figure 2-11](#). Connect the reference air set (regulator/filter and pressure gauge) to the instrument air inlet on the electronics housing and to the inlet side of the dilution air flow meter.
2. Connect the dilution air flow meter output to the dilution air inlet fitting on the sensor housing.
3. Install an air line between the instrument air outlet fitting on the electronics housing and the tee fitting on the sensor housing.

⚠ CAUTION

Failure to use proper gases will result in erroneous readings.

Do not use 100 percent nitrogen as an O₂ low gas.

Emerson recommends using O₂ low gas between 0.4 percent and 2.0 percent O₂.

Do not use gases with hydrocarbon concentrations of more than 40 parts per million.

4. Use one CO gas and two O₂ gases to calibrate the transmitter.
 - CO: 1000 ppm or up to 4 percent, balance air
 - O₂ low gas: 0.4 percent, balance N₂
 - O₂ high gas: 8 percent, balance N₂
5. Connect the output of the test gas sources to the inlet port of the **CAL GAS** flow meter. Install an air line between the flow meter outlet port and the **CAL GAS** inlet fitting on the sensor housing.

Figure 2-11: Pneumatic installation, Rosemount OCX8800 with reference air set without autocalibration

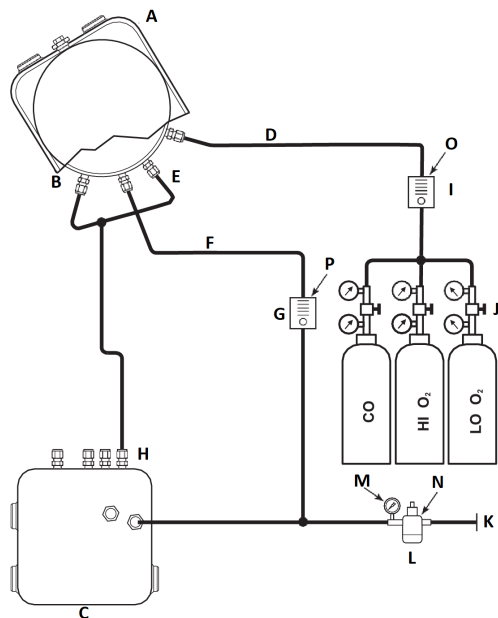

- A. Sensor housing
- B. Eductor air in
- C. Electronics housing
- D. Calibration gas in
- E. Reference air in
- F. Dilution air in
- G. Dilution air flow meter 0.1 scfh
- H. Instrument air out
- I. Calibration gas flow meter (7 scfh, 20 to 30 psig [1.4 to 2.1 barg] recommended)
- J. Two-stage regulators
- K. Instrument air supply
- L. Pressure regulator/filter
General purpose: 35 psig (2.4 barg)
- M. 2-in. pressure gauge, 0 to 60 psig (0 to 4.1 barg)
- N. Combination filter-regulator, 0 to 60 psig (0 to 4.1 barg)
- O. Flow meter, 1-10 scfh
- P. Flow meter, 0.05-0.5 scfh

2.4.2 Reference air set and solenoids option without COe zero function

When the reference air set and test gas solenoids are included with your transmitter, use the following procedure to install the pneumatic system components.

Procedure

1. Install the reference air set according to the instructions in [Reference air set option \(only\)](#), Step 1 through Step 3.

2. Refer to [Figure 2-12](#). Connect the O₂ low gas source to the **CAL GAS LO** O₂ inlet fitting on the electronics housing. Install a shutoff valve and pressure regulator with gauge in the O₂ low supply line, as shown.
3. Connect the O₂ high gas source to the **CAL GAS HI** O₂ inlet fitting. Install a shutoff valve and pressure regulator with gauge in the O₂ high supply line.
4. Connect the CO high gas to the **CAL GAS HI COe** inlet fitting. Install a shutoff valve and pressure regulator with gauge in the **CO** high supply line.
5. Connect the **CAL GAS** outlet fitting of the electronics housing to the inlet port of the **CAL GAS** flow meter. Install an air line between the flow meter outlet port and the **CAL GAS** inlet fitting on the sensor housing.

Figure 2-12: Pneumatic installation, Rosemount OCX8800 with reference air set, solenoids, and autocalibration, without COe zero function

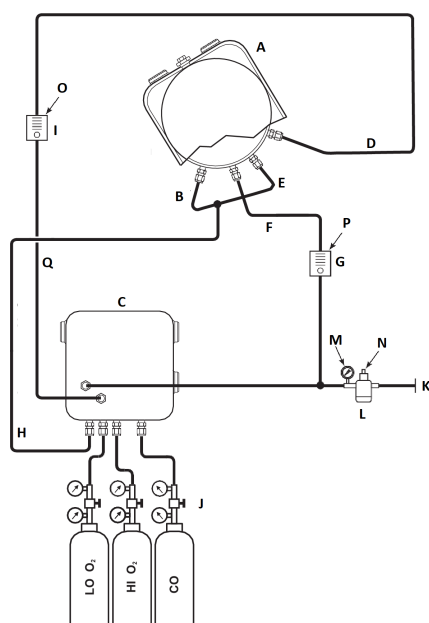

- A. Sensor housing
- B. Eductor air in
- C. Electronics housing
- D. Calibration gas in
- E. Reference air in
- F. Dilution air in
- G. Dilution air flow meter 0.1 scfh
- H. Instrument air out
- I. Calibration gas flow meter (7 scfh, 20 to 30 psig [1.4 to 2.1 barg] recommended)
- J. Two-stage regulators
- K. Instrument air supply
- L. Pressure regulator/filter 35 psig (2.4 barg) for general purpose, 45 psig (3.1 barg) for hazardous areas
- M. 2-in. pressure gauge 0-60 psig (0 to 4.1 barg)
- N. Combination filter-reg. 0-60 psig (0 to 4.1 barg)
- O. Flow meter 1-10 scfh
- P. Flow meter 0.05-0.5 scfh
- Q. Calibration gas out

2.4.3 Reference air set and solenoids option with COe zero function

[Figure 2-13](#) shows the piping arrangement for the transmitter with autocalibration when the COe zero function is used. The arrangement is similar to [Figure 2-12](#), except instrument air is used as the high O₂ test gas.

Figure 2-13: Pneumatic installation, Rosemount OCX8800 with reference air set, solenoids, and autocalibration, with COe zero function

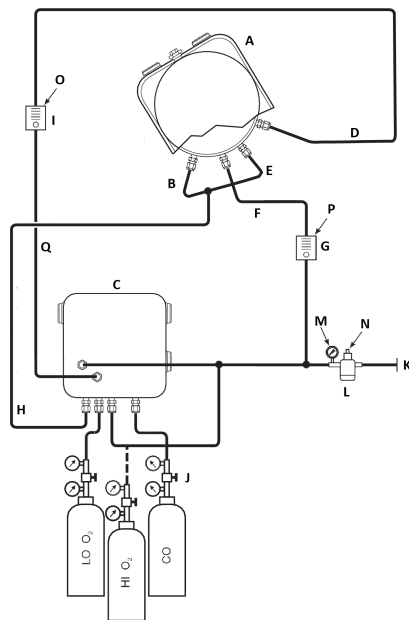

- A. Sensor housing
- B. Eductor air in
- C. Electronics housing
- D. Calibration gas in
- E. Reference air in
- F. Dilution air in
- G. Dilution air flow meter 0.1 scfh
- H. Instrument air out
- I. Calibration gas flow meter (7 scfh, 20-30 psig [1.4 to 2.1 barg] recommended)
- J. Two-stage regulators
- K. Instrument air supply
- L. Pressure regulator/filter 35 psig (2.4 barg) for general purpose, 45 psig (3.1 barg) for hazardous areas
- M. 2-in. pressure gauge, 0-60 psig (0 to 4.1 barg)
- N. Combination filter-regulator, 0-60 psig (0 to 4.1 barg)
- O. Flow meter, 1-10 scfh
- P. Flow meter, 0.05-0.5 scfh
- Q. Calibration gas out

Note

If instrument is to be used as the high O₂ calibration gas, the low O₂ and CO_e calibration gases must also be set to the same pressure.

2.4.4 Reference air set, solenoids, and blowback option with COe zero function

Figure 2-14 shows the piping arrangement for the transmitter with the blowback and autocalibration options when COe zero function is used. The arrangement is similar to Figure 2-12 except instrument air is used as the high O₂ test gas.

Figure 2-14: Pneumatic installation, Rosemount OCX8800 with reference air set, solenoids, and autocalibration, with COe zero function

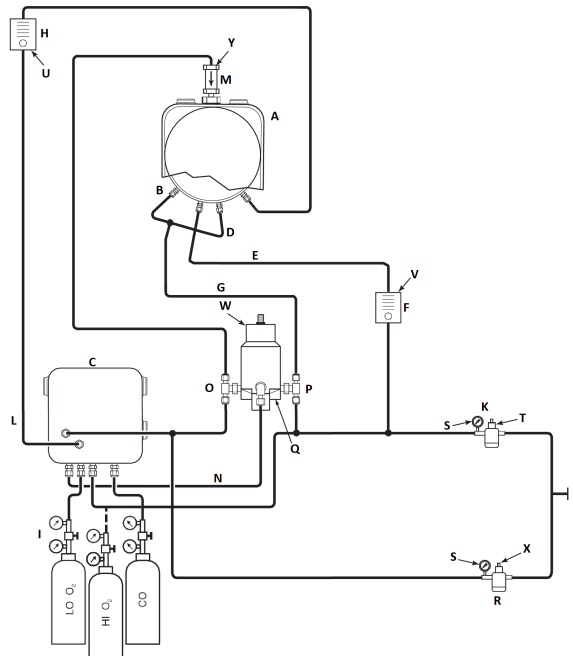

- A. Sensor housing
- B. Eductor air in
- C. Electronics housing
- D. Reference air in
- E. Dilution air in
- F. Dilution air flow meter, 0.1 scfh
- G. Instrument air
- H. Calibration gas flow meter (7 scfh, 20 to 30 psig [1.3 to 2.1 barg] recommended)
- I. Two-stage regulators
- J. Instrument air supply
- K. Pressure regulator/filter
 - General purpose: 35 psig (2.4 barg)
 - Hazardous area: 45 psig (3.1 barg)
- L. Calibration gas out
- M. Check valve
- N. Actuating air
- O. Normally open solenoid valve⁽¹⁾
- P. Normally closed solenoid valve⁽¹⁾
- Q. Blowback valve, air operated
- R. 2-in. pressure gauge, 0 to 60 psig (0 to 4.1 barg)
- S. Combination filter/regulator, 0 to 60 psig (0 to 4.1 barg)
- T. Flow meter, 1-10 scfh
- U. Flow meter, 0.05-0.5 scfh
- V. Pneumatic actuator

⁽¹⁾ During blowback operation, states of both solenoid valves change.

- W. Combination filter/regulator, 0.60 psig (0.04 barg)
- X. Check valve, 5 psig (0.3 barg)

Note

Wall mount the air-operated blowback valve on a suitable mounting plate.

Note

Actuating air pressure at blowback valve inlet port must be at least 51 psig (3.5 barg) to fully actuate the valve.

Note

If instrument is to be used as the high O₂ calibration gas, the low O₂ and COe calibration gases must also be set to the same pressure.

2.5 Initial start-up

Observe the following Caution.

Refer to [Configuration and startup](#) for start-up information.

⚠ CAUTION

Damage can result from having a cold transmitter exposed to the process gases.

If ducts will be washed down during outages, make sure to power down the transmitter and remove it from the wash area.

Upon completing installation, make sure that the transmitter is turned on and operating prior to firing up the combustion process.

During outages, and whenever possible, leave the transmitter running to prevent condensation and premature aging from thermal cycling.

3 Configuration and start-up

⚠ WARNING

Electric shock

Failure to install covers and ground leads could result in serious injury or death.
Install all protective equipment covers and ground leads after installation.

3.1 Verify installation

Ensure that the transmitter is installed correctly. Verify mechanical installation and all electrical and pneumatic connections.

Refer to [Install](#).

⚠ CAUTION

Equipment damage

Damage can result from having a cold transmitter exposed to the process gases.

Make sure that the transmitter is turned on and operating prior to firing up the combustion process.

During outages and whenever possible, leave all transmitters running to prevent condensation and premature aging from thermal cycling.

3.1.1 Verify configuration - HART® electronics

There are three switches on the microprocessor board which are user configurable for the Rosemount OCX8800 with HART electronics ([Figure 3-1](#)).

SW1 determines if the O₂ 4-20 mA signal is internally or externally powered. SW2 determines if the COe 4-20 mA signal is internally or externally powered. SW3 sets the rail limits for the O₂ and COe 4-20 mA signals and configures the sample line heater control circuit. All switches are accessible through holes in the electronics box.

⚠ CAUTION

Equipment damage

If defaults are changed under power, damage to the electronics may occur.

Remove power from the transmitter before changing defaults.

Verify that the following switch settings are correct for your installation.

Figure 3-1: Rosemount OCX8800 Defaults - HART Electronics

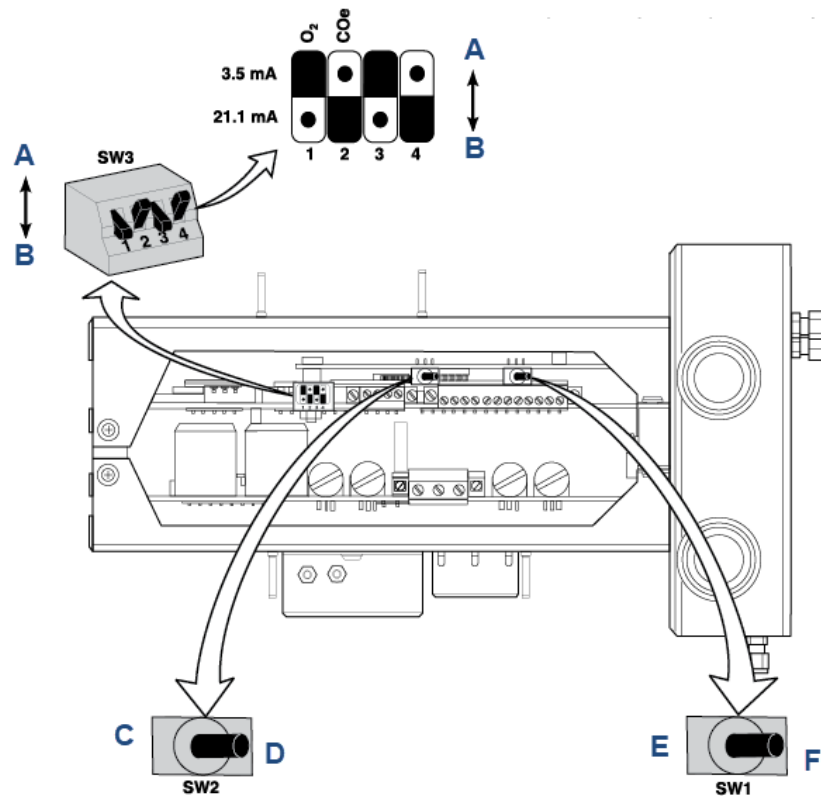

- A. Open
- B. Closed
- C. Internal: CO_e 4-20 mA is internally powered.
- D. External: CO_e 4-20 mA requires an external power supply (default).
- E. Internal: O₂ 4-20 mA is internally powered.
- F. External: O₂ 4-20 mA requires an external power supply (default).

Switch default positions shown.

O₂ 21.1 mA/3.5 mA: O₂ 4-20 mA signal

- Rail limits:
 - Open Low: 3.5 mA
 - Closed High: 3.5 mA

CO_e 21.1 mA/3.5 mA: CO_e 4-20 mA signal

- Rail limits:
 - Open Low: 3.5 mA
 - Closed High: 3.5 mA

SW1: The two settings are internally or externally powering the O₂ 4-20 mA signal. The factory setting is for the O₂ 4-20 mA signal to be internally powered.

SW2: The two settings are internally or externally powering the CO_e 4-20 mA signal. The factory setting is for the CO_e 4-20 mA signal to be internally powered.

SW3: The factory sets this switch as follows:

- Position 1 determines the O₂ 4-20 mA signal rail limit. The settings are high, 21.1 mA, or low, 3.5 mA. The factory setting is low, 3.5 mA.
- Position 2 determines the CO_e 4-20 mA signal rail limit. The settings are high, 21.1 mA, or low, 3.5 mA. The factory setting is high, 21.1 mA.
- Set positions 3 and 4 as shown for proper software control of the device heaters.

3.1.2 Verify configuration - FOUNDATION™ Fieldbus electronics

There is one switch on the microprocessor board which must be set for the Rosemount OCX8800 with FOUNDATION Fieldbus electronics (Figure 3-2). SW3 configures the sample line heater control circuit. The switch is accessible through holes in the electronics box.

⚠ CAUTION

Equipment damage

If defaults are changed under power, damage to the electronics may occur.

Remove power from the transmitter before changing defaults.

Figure 3-2: Rosemount OCX8800 Defaults - FOUNDATION Fieldbus Electronics

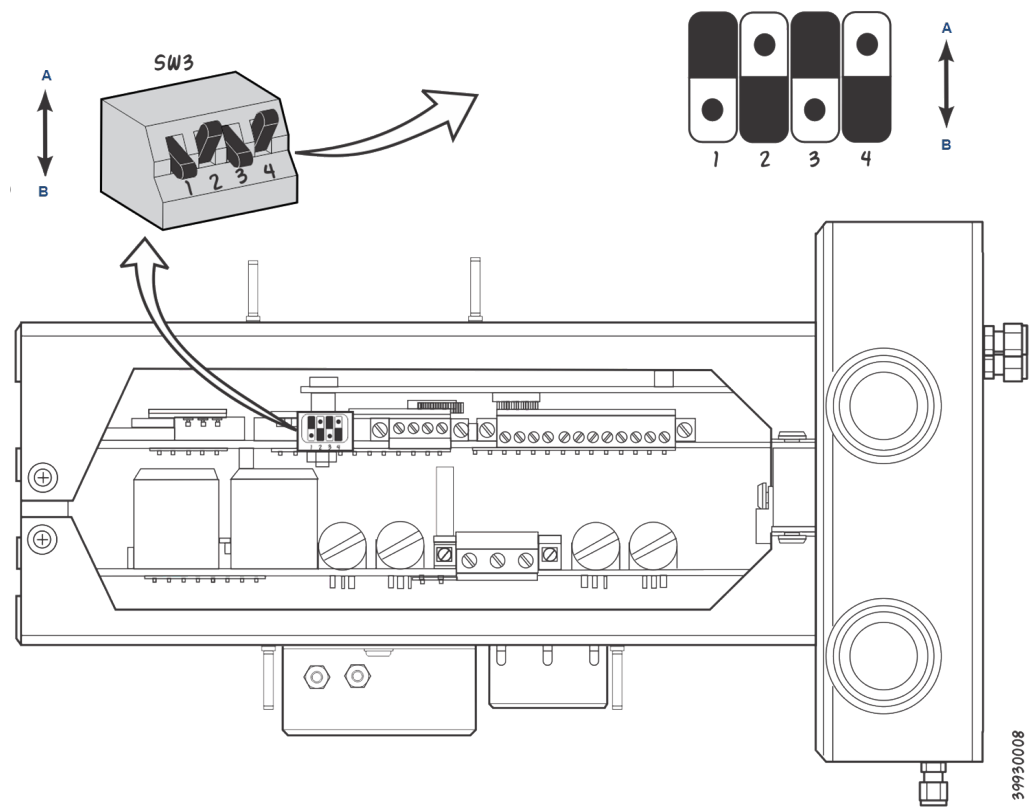

- A. Open
- B. Closed

Switch default positions shown.

Verify that the following switch settings are correct for your transmitter installation:

SW3: The factory sets this switch as follows:

- Position 1 not used.
- Position 2 not used.

Positions 3 and 4 must be set up as shown for proper software control of the device heaters.

3.2 Initial power up

Allow adequate time (approximately 60 minutes) for the heaters to begin operation and for the transmitter to reach normal operating temperature on power up.

Normal operating temperature for the O₂ cell is 1357 °F (736 °C). Normal operating temperature for the combustibles cell is 572 °F (300 °C). The normal sample line temperature is 338 °F (170 °C). During this time, the eductor air solenoid will remain closed, so no sample is pulled through the transmitter. When the transmitter reaches operating temperature, the solenoid will energize, eductor air will begin to flow, and the transmitter will begin normal operation.

3.3 Setting test gas values

Use HART®/AMS or the optional local operator interface (LOI) to set test gas values for calibration.

Refer to [Using the local operator interface \(LOI\)](#) or [Using HART® communications](#) for more information.

3.3.1 Set test gas values with HART®

Procedure

1. Use the Field Communicator software to access the HART® menu.
2. From the **DETAILED SETUP** menu, select **O₂ CALIB PARAMS**.
3. From **O₂ CAL PARAMS**, select **O₂ HIGH GAS**. Enter the percent O₂ used for the high O₂ test gas.
4. From **O₂ CAL PARAMS**, select **O₂ LOW GAS**. Enter the percent O₂ used for the low O₂ test gas.
5. From the **DETAILED SETUP** menu, select **COe CALIB PARAMS**.
6. From **COe CAL PARAMS**, select **COe Test Gas**. Enter the CO concentration (ppm) used for COe test gas.

3.3.2 Set test gas values with FOUNDATION™ Fieldbus Communicator

Procedure

1. Use the Field Communicator software to access the FOUNDATION Fieldbus menu.
2. From the **TRANSDUCER** menu, select O₂ CAL.
3. From the O₂ CAL menu, select O₂ CAL SETUP.

4. From the O₂ CAL SETUP menu, select O₂ HIGH GAS. Enter the percent O₂ used for the high test gas.
5. From O₂ CAL SETUP, select O₂ LOW GAS. Enter the percent O₂ used for the low test gas
6. From the **TRANSDUCER** menu, select COe CAL SETUP.
7. From **COe CAL SETUP**, select COe Test Gas. Enter the CO concentration (ppm) used for the COe test gas.

3.3.3 Set test gas values with the local operator interface (LOI)

Procedure

1. Use the "Z" pattern to enter the LOI menu tree.
2. From the **SYSTEM** menu, select **Calib Setup**.
3. From **Calib Setup**, select **O₂ High Gas %**. Enter the percent O₂ used for the high O₂ test gas.
4. Press **Down**, and the next selection will be **O₂ Low Gas %**. Enter the percent O₂ used for the low O₂ test gas.
5. Press **Down** several times to display **COe Test Gas**. Enter the CO concentration (ppm) used for COe test gas.

3.4 Reset

Whenever you correct an equipment alarm or fault condition, the transmitter reverts to normal operation or continues to indicate an alarm status condition.

If the equipment does not revert to normal operation when a fault condition is cleared, or if instructed to do so in [Troubleshoot](#), use the following procedure to reset the transmitter.

3.4.1 Reset with the local operator interface (LOI)

Procedure

1. Use the Z pattern to enter the LOI menu tree.
See [Using the local operator interface \(LOI\)](#).
2. Select the **SYSTEM** submenu.
3. From the **SYSTEM** submenu, select the **Status** submenu.
4. From the **Status** submenu, select **Reset Device**.

The transmitter resets, and the LOI reverts to the normal operation display.

3.4.2 Reset with Field Communicator

Remove the transmitter from the process loop and recycle power.

3.5 Calibration solenoids

Emerson can provide the transmitter with optional calibration solenoids for autocalibration. The transmitter's software controls the solenoids, which automatically switch in the proper calibration gas during the calibration cycle.

3.5.1 Configure the calibration solenoids with the Field Communicator - HART®

Procedure

1. Use the Field Communicator to access the **HART** menu.
2. From the **DETAILED SETUP** menu, select CAL SETUP.
3. From the **CAL SETUP** menu, select O₂ CAL PARAMS/COe CAL PARAMS.
4. From the O₂ CAL PARAMS/COe CAL PARAMS, select Solenoids. Select Yes to enable the solenoids.

3.5.2 Configure the calibration solenoids with the Field Communicator - FOUNDATION™ Fieldbus

Procedure

1. Use the Field Communicator to access the Fieldbus menu.
2. From the **TRANSDUCER** block menu, select O₂ CAL/COE CAL.
3. From the O₂ CAL/COE CAL menu, select O₂ CAL SETUP/COE CAL SETUP.
4. From the O₂ CAL SETUP/COE CAL SETUP menu, select Solenoids. Select Present to enable the solenoids.

3.5.3 Configure the calibration solenoids with the LOI

Procedure

1. Use the Z pattern to enter the LOI menu tree.
2. From the **SYSTEM** menu, select Calib Setup.
3. From the **Calib Setup** menu, select Use Solenoids. Select Yes to enable the solenoids.

3.6 Blowback feature

The blowback feature blows instrument air back through the center of the internal filter and out the sample tube of the probe. This removes built up dirt and particulate from the internal filter, sample line, and any optional in-situ filter on the end of the sample tube.

The blowback feature is normally used in systems that have heavy particulate in the process stream. The blowback feature requires the optional blowback hardware to be properly installed external to the transmitter. A Rosemount OCX8800 shipped from the factory must be configured before blowback can be implemented. This same process must be performed any time a replacement card stack is installed.

3.6.1 Configure blowback with the Field Communicator - HART®

Procedure

1. Use the Field Communicator or AMS software to access the **HART** menu.
2. From the **DETAILED SETUP** menu, select INPUT/OUTPUT.
3. From the **INPUT/OUTPUT** menu, select BLOWBACK.
4. From the **BLOWBACK** menu, select BIBk Enabled. Select Yes to enable blowback. Also set the following parameters:
 - BIBk Intrvl: Length of time between blowback events (60 minutes recommended).
 - BIBk Period: Length of time blowback is activated (five seconds recommended).
 - BIBk Purge Time: Length of time after blowback is complete before oxygen / combustibles readings are considered valid (set as required by the application).
5. Manually initiate blowback from **DIAG/SERVICE**.

3.6.2 Configure blowback with the Field Communicator - FOUNDATION™ Fieldbus

Procedure

1. Use the Field Communicator or AMS software to access the **Fieldbus** menu.
2. From the **TRANSDUCER** block menu, select Alarm Relay/Blowback.
3. From the **Alarm Relay/Blowback** menu, select Blowback.
4. From the **Blowback** menu, select Blowback Enabled. Also set the following parameters:
 - Blowback Interval: Length of time between blowback events (60 minutes recommended).
 - Blowback Period: Length of time blowback is activated (Five seconds recommended).
 - Blowback Purge Time: Length of time after blowback is complete before oxygen/ combustibles readings are considered valid (set as required by the application).
 - Initiate Blowback: Initiates a blowback event manually.

3.6.3 Configure blowback with the LOI

Procedure

1. Use the Z pattern to enter the LOI menu tree.
2. From the **SYSTEM** menu, select Blow Back.
3. From the **Blow Back** menu, select Blow Bk Enable. Select Yes to enable blowback. Also set the following parameters:
 - Blow Bk Intrvl: Length of time between blowback events. Range is 0 to 32,000 minutes. Default is 60 minutes. Emerson recommends 60 minutes.
 - Blow Bk Period: Length of time blowback in activated. Range is one to five seconds. Default is two seconds. Emerson recommends five seconds.

- Blow Bk Purge: Length of time after blowback is complete before oxygen/ combustibles readings are considered valid. Range is 0 to 500 seconds. Default is 88 seconds. Set as required by the application.
- Force Blow Bk: Initiates a blow back event manually.

3.7 Calibration verify feature

The calibration verify feature flows one or more calibration gases to verify the analyzer is reading correctly. The calibration verify feature flows each calibration gas on demand to verify calibration, but does not change the slope or constant of the current calibration. This function uses the same gas flow and purge times from the basic calibration setup.

The calibration verify feature is only valid if the transmitter is supplied with calibration solenoids and the solenoids have been activated.

⚠ WARNING

During the calibration verify function, the analog output signals track the oxygen and combustibles readings.

To avoid a potentially dangerous operating condition, remove the transmitter from the automatic combustion control loop before performing the calibration verify procedure.

3.7.1 Verify calibration with the Field Communicator - HART®

Procedure

1. Use the Field Communicator or AMS software to access the **HART** menu.
2. From the **DEVICE SETUP** menu, select DIAG/SERVICE.
3. From the **DIAG/SERVICE** menu, select CALIBRATION.
4. From the **CALIBRATION** menu, select CAL VERIFY. Select Verify Calibration. From this menu, select the functions as follows:
 - Flow High O₂ Gas: Flows the high O₂ test gas for the time specified in the calibration setup.
 - Flow Low O₂ Gas: Flows the low O₂ test gas for the time specified in the calibration setup.
 - Flow High COe Gas: Flows the COe test gas for the time specified in the calibration setup.
 - Purge Gas: Initiates a delay for the specified purge time before oxygen/ combustibles readings are considered valid.

Note

A purge automatically follows a gas flow.

3.7.2 Verify calibration with the Field Communicator - FOUNDATION™ Fieldbus

Procedure

1. Use the Field Communicator or AMS software to access the **Fieldbus** menu.

2. From the **TRANSDUCER** block menu, select METHODS.
3. Set the Mode to OOS (out of service) before starting the calibration verify process.
4. From the **METHODS** menu, select OCX Cal Verify. From this menu, select the functions as follows:
 - Flow High O₂ Gas: Flows the high O₂ test gas for the time specified in the calibration setup.
 - Flow Low O₂ Gas: Flows the low O₂ test gas for the time specified in the calibration setup.
 - Flow High COe Gas: Flows the COe test gas for the time specified in the calibration setup.
 - Purge gas: Initiates a delay for the specified purge time before oxygen/combustibles readings are considered valid.

Note

A purge automatically follows a gas flow.

3.7.3 Verify calibration with the LOI

Procedure

1. Use the Z pattern to enter the LOI menu tree.
2. From the **CALIBRATION** menu, select Cal Verify.
3. From the **Cal Verify** menu, select the functions as follows:
 - Flow High Gas: Flows the high O₂ test gas for the time specified in the calibration setup.
 - Flow Low Gas: Flows the low O₂ test gas for the time specified in the calibration setup.
 - Flow COe Gas: Flows the COe gas for the time specified in the calibration setup.
 - Purge: Initiates a delay for the specified purge time before oxygen/combustibles readings are considered valid.

Note

A purge automatically follows a gas flow.

3.8 Calibration tolerance feature

The calibration tolerance feature provides a mechanism to fail a calibration if the calibration measurement does not fall within a specific tolerance of the test gas value. The tolerance is preset within the transmitter software and is not user-adjustable.

The tolerance is different between the oxygen and combustibles test gases. For oxygen, the calibration fails if the measured value differs by more than $\pm 10\%$ of the configured value. For combustibles, the calibration fails if the measured value differs by more than $\pm 30\%$ of the configured value.

A transmitter shipped from the factory must be configured before the calibration tolerance feature can be implemented. The same process must be performed any time a replacement card stack is installed.

3.8.1 Configure calibration tolerance with the Field Communicator - HART®

Complete the following steps to configure the calibration tolerance with the Field Communicator using the HART communication protocol.

Procedure

1. Use the Field Communicator or AMS software to access the **HART** menu.
2. From the **DETAILED SETUP** menu, select **CAL SETUP**.
3. From the **CAL SETUP** menu, select **O₂ CAL PARAMS**.
4. To enable the calibration tolerance feature for the oxygen calibration, from the **O₂ CAL PARAMS** menu, select **O₂ Tol Check**. Select **On** to enable the calibration tolerance feature.
5. Go back to the **CAL SETUP** menu and select **COe CAL PARAMS**.
6. To enable the calibration tolerance for the combustibles calibration, from the **COe CAL PARAMS** menu, select **COe Tol Check**. Select **On** to enable the calibration tolerance feature.

3.8.2 Configure calibration tolerance with the Field Communicator - FOUNDATION™ Fieldbus

Procedure

1. Use the Field Communicator or AMS software to access the **Fieldbus** menu.
2. From the **TRANSDUCER** block menu, select **O₂ CAL/COe CAL**.
3. From the **O₂ CAL/COe CAL** menu, select **O₂ CAL SETUP/COe CAL SETUP**.
4. From the **O₂ CAL SETUP/COe CAL SETUP** menu, select **O₂ Tolerance Check/COe Tolerance Check**. Select **Yes** to enable the calibration tolerance feature.

3.8.3 Configure calibration tolerance with the LOI

Procedure

1. Use the Z pattern to enter the LOI menu tree.
2. From the **SYSTEM** menu, select **Calib Setup**.
3. From the **Calib Setup** menu, select the following:
 - **O₂ Tol Check**: Select **Yes** to enable the calibration tolerance feature for the oxygen calibration.
 - **Comb Tol Check**: Select **Yes** to enable the calibration tolerance feature for the combustibles calibration.

3.9 COe purge/zero feature

This feature provides a way to periodically flood the COe sensor with air to perform two functions:

1. Provide additional oxygen to help burn off any combustible residue from the COe sensor.
2. Allow for optional adjustment of the COe calibration constant.

If the transmitter is configured to update the COe calibration constant, only the constant is updated. The COe calibration slope is not affected. To update both the constant and slope, you must do a full calibration.

The feature uses the calibration solenoid that is also used for high O₂ test gas and COe zero gas. For the feature to work properly, instrument air is used as the high O₂ test gas. This also requires the high O₂ test gas value to be set at 20.95 percent. You can install a two-way valve to switch the high O₂ test gas between the normal calibration gas and instrument air. This allows the transmitter to use a specified calibration gas for calibration, then instrument air for the COe zero feature. Switching between the two gases must be manually coordinated between scheduled calibrations and COe zero events.

When the COe zero feature is used, special pneumatic connections are required.

The COe zero feature is only valid if the transmitter is supplied with calibration solenoids and the solenoids have been activated.

A Rosemount OCX8800 shipped from the factory must be configured before the COe zero feature can be implemented. This same process must be performed any time a replacement card stack is installed.

⚠ WARNING

During the COe Zero Function, the analog output signals may track the oxygen and combustibles readings if configured to do so.

To avoid a potentially dangerous operating condition, remove the transmitter from the automatic combustion control loop before performing the COe Zero Function procedure.

Note

At the completion of the COe Zero Function, the COe analog output signal will change if the Zero Update parameter is set to Yes.

3.9.1 Configure COe zero with the Field Communicator - HART®

Procedure

1. Use the Field Communicator or AMS software to access the **HART** menu.
2. From the **DETAILED SETUP** menu, select **INPUT/OUTPUT**.
3. From the **INPUT/OUTPUT** menu, select **COE ZERO**.
4. From the **COE ZERO** menu, select the functions as follows:
 - Zero Enabled: Select **Yes** or **No** to enable or disable this feature.
 - Zero Intrvl: Length of time between COe zero events. Range is 60 to 480 minutes. Default is 60 minutes.
 - Zero Flow: Length of time COe zero gas flows. Range is 120 to 600 seconds. Default is 120 seconds.
 - Zero Purge: Length of time after COe zero is complete before oxygen/ combustibles readings are considered valid. Range is 60 to 180 seconds. Default is 60 seconds. Total duration of this function is flow time plus purge time.
 - Zero Tracks: Determines if the analog output signals track or hold during the function. Valid choices are **None**, **Both**, **COe**, and O₂.
 - Zero Update: Determines if the COe calibration constant is updated at the end of the function. Valid choices are **Yes** and **No**. A **Yes** choice will cause the COe calibration constant to update.

Note

At the completion of the COe Zero Function, the COe analog output signal will change if the Zero Update parameter is set to **Yes**.

3.9.2 Configure COe zero with the Field Communicator - FOUNDATION™ Fieldbus

Procedure

1. Use the Field Communicator or AMS software to access the **Fieldbus** menu.
2. From the **TRANSDUCER** block menu, select **COe ZERO**.
3. From the **COe ZERO** menu, select the functions as follows:
 - COe Zero Enable: Select **Yes** or **No** to enable or disable this feature.
 - COe Zero Interval: Length of time between COe zero events. Range is 60 to 480 minutes. Default is 60 minutes.
 - COe Zero Duration: Length of time the COe zero gas flows. Range is 120 to 600 seconds. Default is 120 seconds.
 - COe Zero Purge Time: Length of time after COe zero is complete before oxygen/ combustibles readings are considered valid. Range is 60 to 180 seconds. Default is 60 seconds. Total duration of this function is flow time plus purge time.
 - COe Zero Output Track: Determines if the analog output signals track or hold during the function. Valid choices are **None**, **Both**, **COe**, and **O₂**.
 - COe Zero Update: Determines if the COe calibration constant is updated at the end of the function. Valid choices are **Yes** and **No**. A **Yes** choice causes the COe calibration constant to update.

3.9.3 Configure COe zero with the LOI

Procedure

1. Use the Z pattern to enter the LOI menu tree.
2. From the **SYSTEM** menu, select **Input/Output**.
3. From the **Input/Output** menu, select **COe Zero**. Select the functions as follows:
 - COe Zero Enable: Select Yes or No to enable or disable this feature.
 - COe Zero Intrvl: Length of time between COe zero events. Range is 60 to 480 minutes. Default is 60 minutes.
 - COe Zero Flow: Length of time COe zero gas flows. Range is 120 to 600 seconds. Default is 120 seconds.
 - COe Zero Purge: Length of time after COe zero is complete before oxygen/ combustibles readings are considered valid. Range is 60 to 180 seconds. Default is 60 seconds. Total duration of this function is flow time plus purge time.
 - COe Zero Tracks: Determines if the analog output signals track or hold during the function. Valid choices are **None**, **Both**, **COe**, and **O₂**.
 - COe Zero Update: Determines if the COe calibration constant is updated at the end of the function. Valid choices are **Yes** and **No**. A **Yes** choice will cause the COe calibration constant to update.

4 Using the local operator interface (LOI)

This section describes the installation and operation of the LOI module in the Rosemount OCX8800.

4.1 Display orientation

The local operator interface (LOI) module mounts to a connector on the LOI board.

The board is installed on the end of the electronics stack in the electronics housing, [Figure 4-1](#). There are four mating connectors on the back of the LOI module that allow the LOI to be oriented as desired.

Figure 4-1: LOI components mounting

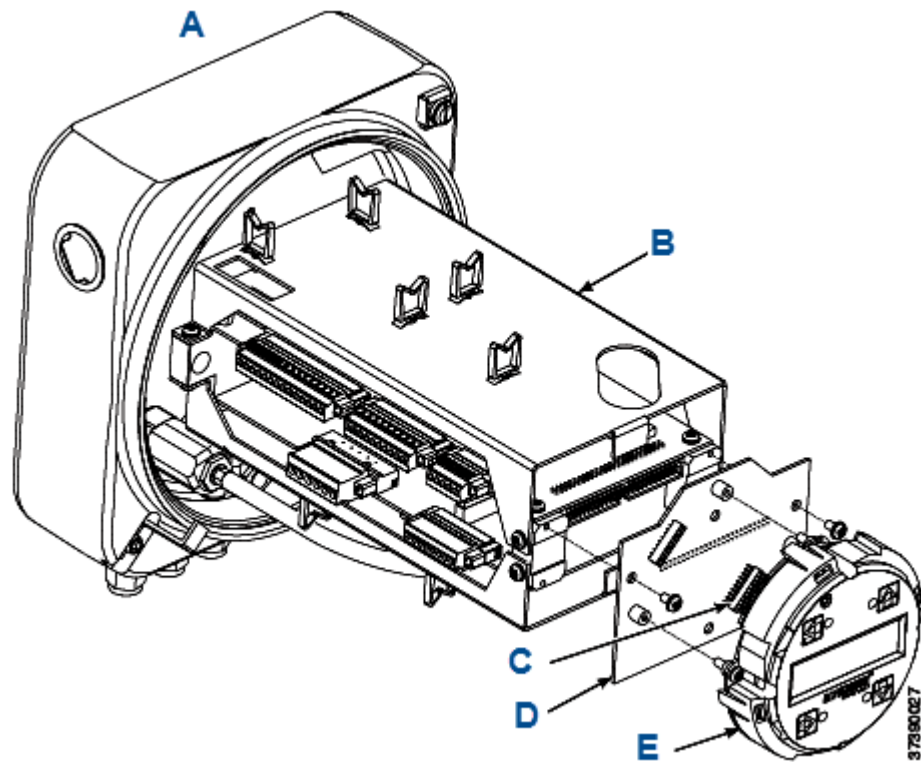

- A. Electronics housing (cover removed)
- B. Electronics stack
- C. LOI connector
- D. LOI board
- E. LOI module

4.2 Local operator interface (LOI) controls

4.2.1 Overview

The local operator interface (LOI), shown in [Figure 4-2](#), uses a bright blue gas-fluorescent display. Intensity is adjustable.

There is an infrared light-emitting diode (LED) source and a detector for each key. The detectors can detect a finger placed above the button through the glass window. There is no need to open the instrument in bad weather or in hazardous areas in order to access the electronics.

The transmitter also uses HART® or FOUNDATION™ Fieldbus communications, permitting access to all instrument functionality anywhere the digital O₂ signal terminates via a Field Communicator. The transmitter also uses HART® communications, permitting access to all instrument functionality anywhere the 4-20 mA signal terminates via a HART Field Communicator.

Figure 4-2: LOI Assembly

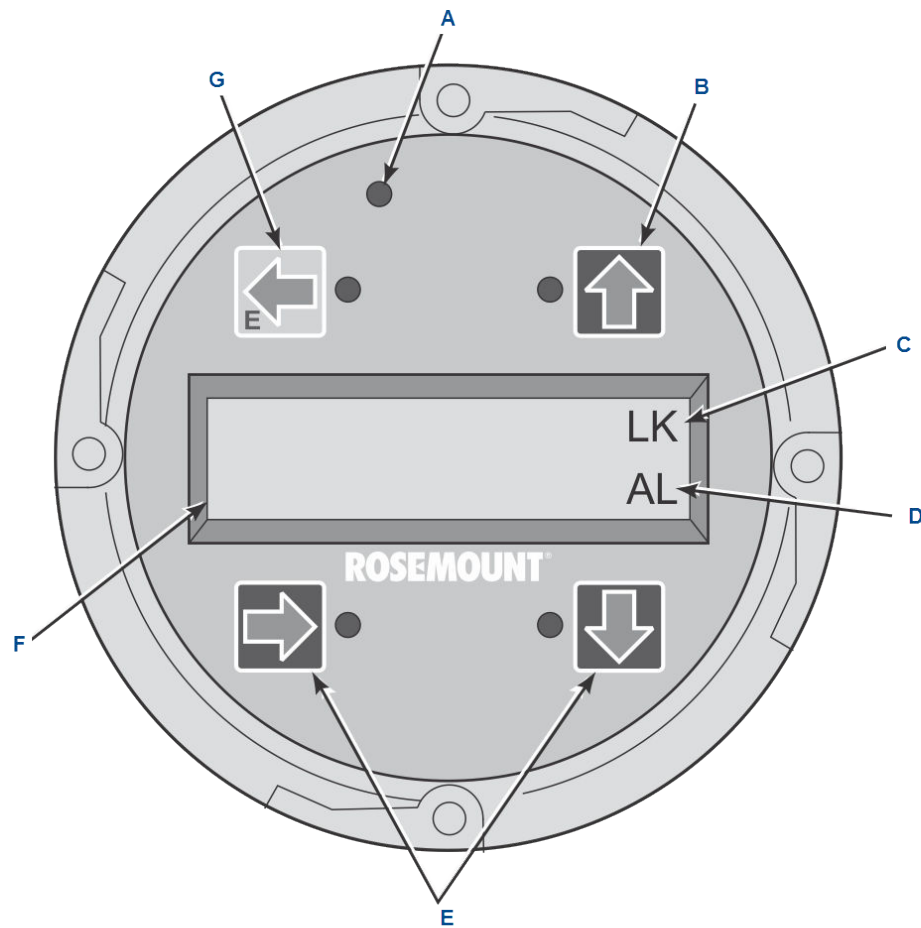

37390042

- A. Touch confirmation LED
- B. Selection arrow
- C. Lockout notation
- D. Status code
- E. Selection arrows
- F. Display window
- G. Selection arrow (**Enter** key)

4.2.2 Local operator interface (LOI) key functions

The gray (top left) key will move one level higher in the menu structure. When entering parameter values (numbers), this key moves the cursor to the left. The left-pointing key also doubles as an **Enter** key, used after the digits of a parameter value are entered and the cursor is moved to its left-most position. When you touch the **Enter** key, the new parameter value, if accepted, will appear in the top line of the display.

Use the blue (bottom left) key as a selector when choosing from among several menu items. This right-pointing key also will move the cursor to the right when entering the digits of a new parameter value.

Use the up and down pointing keys to increment up and down when selecting from a vertical list of menu items. You can also use these keys for incrementing values up and down for new data input.

4.2.3 Lockout

The local operator interface (LOI) has a lockout feature that prevents nuisance actuation by someone brushing against the glass window, raindrops, dirt, insects, etc. This lockout mode is automatically established when no buttons are pushed for 30 seconds (default). This countdown to lockout is configurable.

In order to unlock the display, input a Z pattern (Figure 4-3). First, touch the top left (gray) **Enter** key. Next, touch the top right key, followed by the bottom left key and the bottom right key. The **LK** notation in the upper right corner of the display will disappear. Touch **Enter** once more to enter into the menu structure. Whenever you touch a key, additional time to lockout is provided, so that the lockout feature does not become a nuisance. This additional revert time is one hour (default) and is also user configurable.

⚠ CAUTION

Excessive dust can prevent the LOI from entering lockout. This condition can cause uncommanded operations to occur.

Always clean dust and soil away from the LOI screen each time the LOI is used.

Figure 4-3: Z Pattern Entry

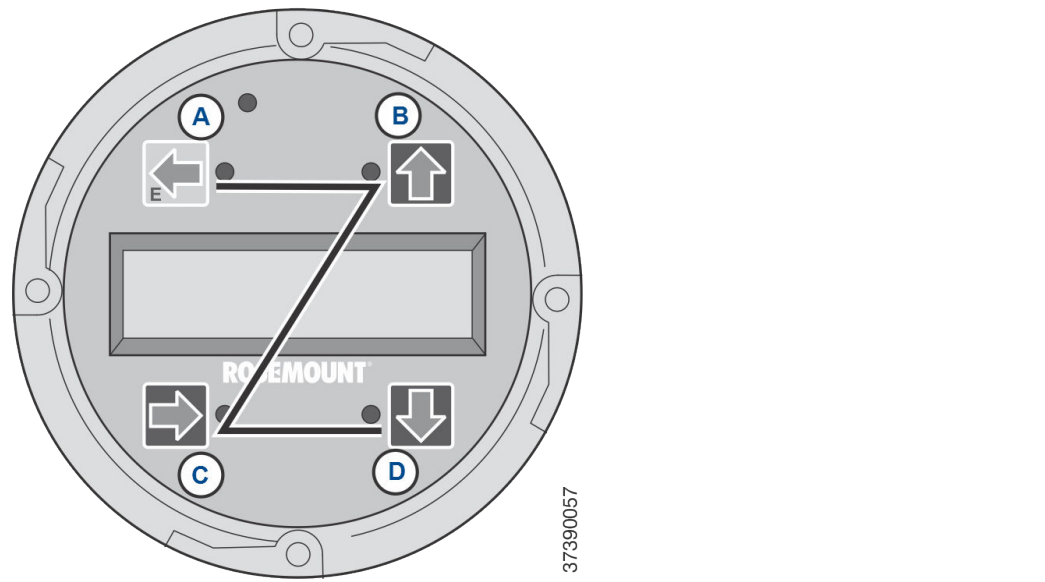

4.2.4 Local operator interface (LOI) status codes

The LOI display shows a status code in the lower right hand corner of the display. There are nine status codes to indicate the existing status of the device during operation.

The status code descriptions are shown in [Table 4-1](#).

Table 4-1: LOI Status Codes

Code	Description
AL	Alarm: The transmitter is in a recoverable alarm state.
BL	Blowback: A blowback cycle is active.
CA	Calibration: A calibration cycle is active.
CV	Calibration Verify: A calibration verify task is in progress.
NM	Normal: The transmitter is in a normal operating mode.
PO	Power On: A system level initialization sequence is active. This continues for several seconds.
SF	System Fault: The transmitter is in a non-recoverable alarm condition. To resume operation, reset or cycle the power off and on.
ST	Stabilize: The transmitter's heater control is stabilizing (after warm-up). Sensors are warming up to operating temperature.
WU	Warm-Up: The transmitter's heaters are ramping up to operating temperature.

4.3 Local operator interface (LOI) menu tree

[Figure 4-4](#) displays the LOI menu tree that is specific to the Rosemount OCX8800.

Figure 4-4: LOI Menu Tree

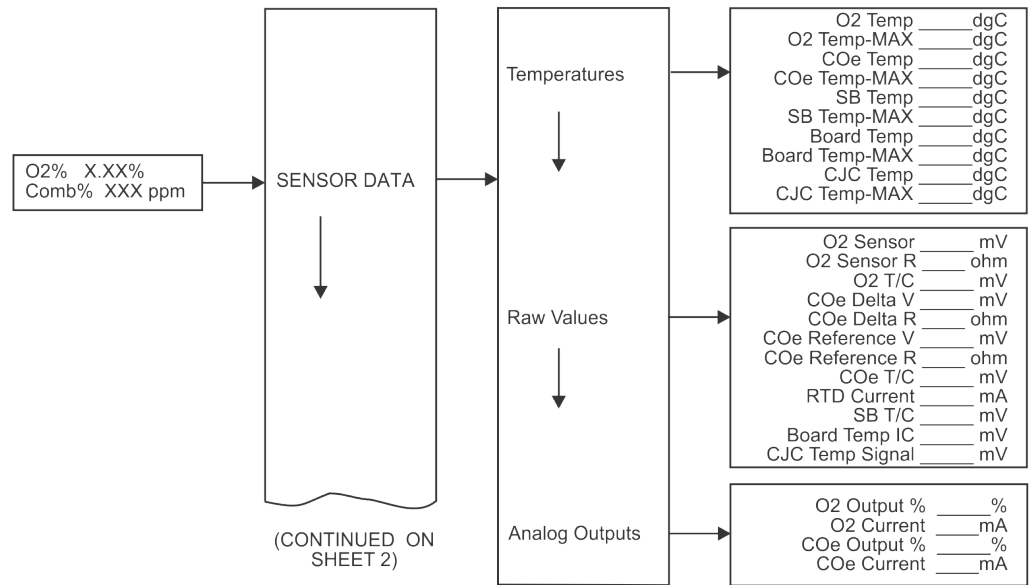

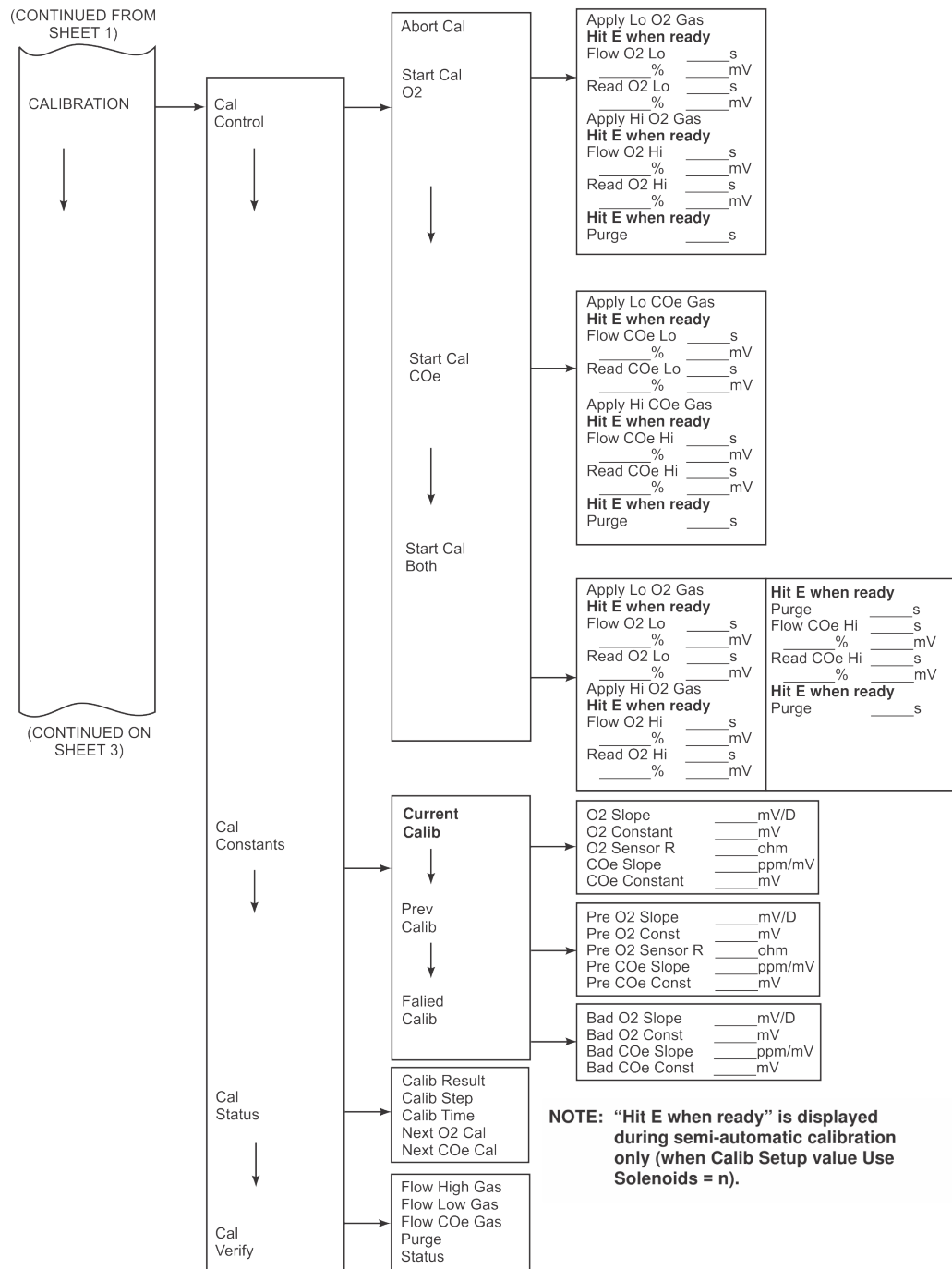

(CONTINUED FROM SHEET 2)

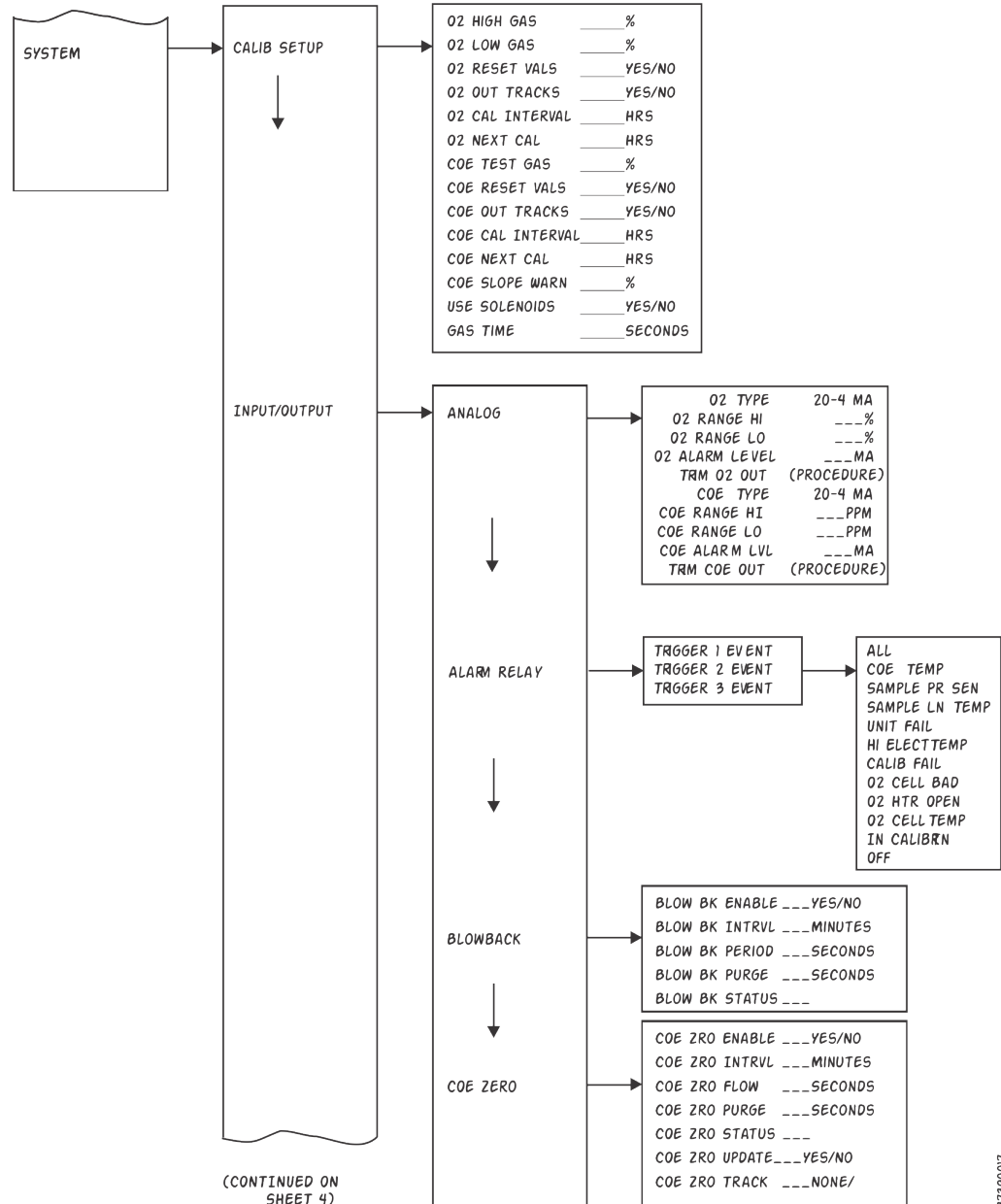

(CONTINUED ON SHEET 4)

37390017

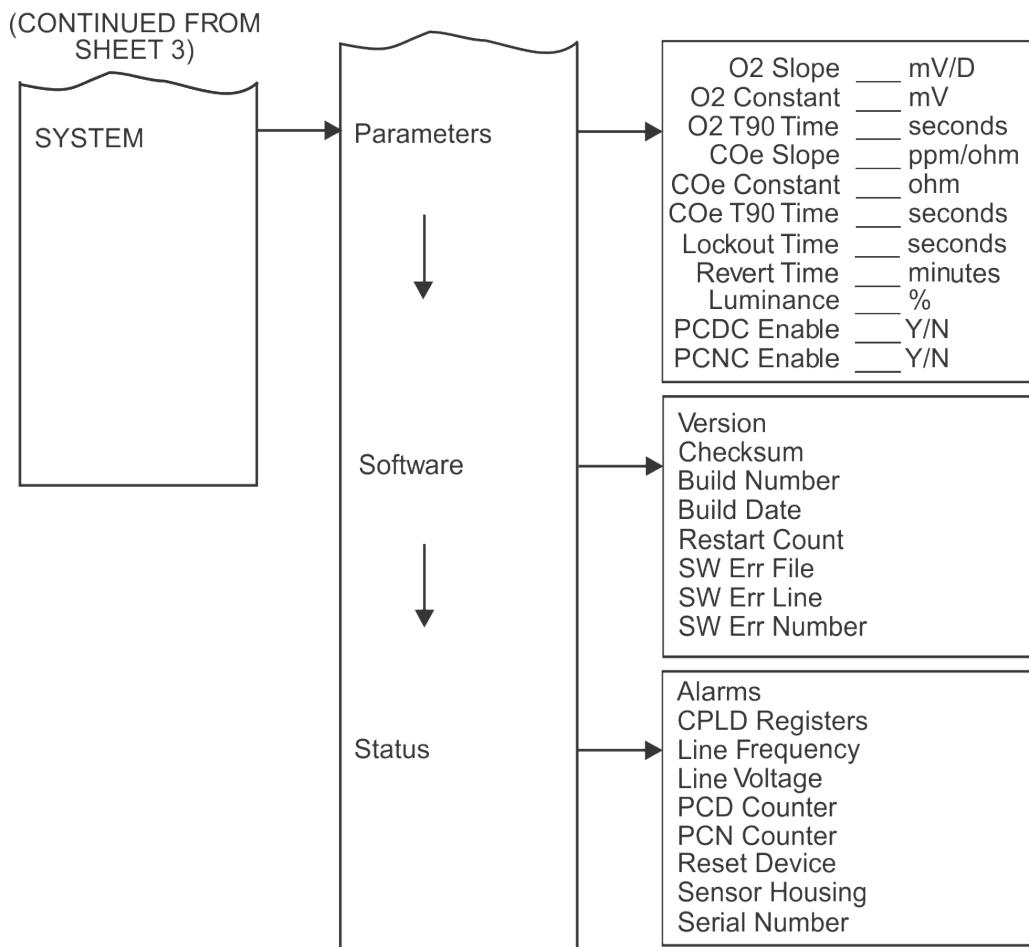

4.3.1 First column submenus

From the operating display (**O₂ % and COe ppm**), the left-pointing **Enter** key is the only option to move into the first column submenus of the local operator interface (LOI) menu tree.

The first column contains three submenus: **SENSOR DATA**, **CALIBRATION**, and **SYSTEM**. When you select **Right**, **SENSOR DATA** is displayed on the operating display. Use **Up** or **Down** to move to the other first column submenus.

4.3.2 Second column submenus

From the first column submenu, press **Right** to move the display into the second column submenu.

Press **Up** and **Down** to move the display to the second column submenus of the first column submenu selected. Press **Left** to move the display back to the first column submenu.

4.3.3 Third and fourth column submenus

From the second column submenu, press **Right** to move the display into the third column submenu.

The third column submenu may be another menu or a list of parameters. Press **Up** and **Down** to move the display to the different parameters or menus. The third or fourth column submenu may be a parameter list. When a parameter list is displayed, the cursor blinks. Press **Up** and **Down** to select the value for the parameter displayed.

4.4 D/A trim procedures

4.4.1 O₂ D/A trim using the local operator interface (LOI)

Refer to the LOI menu tree in [Figure 4-4](#).

⚠ WARNING

To avoid a potentially dangerous operating condition, remove the transmitter from the automatic combustion control loop before you start the D/A trim procedure.

Procedure

1. From the operating display, press **Left** to select the first column submenu. Press **Down** to select **SYSTEM**.
2. From the **SYSTEM** menu, press **Down** to select **Input/Output**. Press **Right** to select the **Analog** parameters list.
3. Scroll down to the item, **Trim O₂ Out**. Press **Right** to start the O₂ trim procedure.

Note

If you wish to exit D/A trim with no changes, step through the procedure using **Yes** responses and enter no meter readings.

4. Remove the electronics housing cover.
5. Connect a digital multimeter to read the milliamp output from the O₂ D/A converter circuit. Connect the positive lead to the **AOUT1+** terminal and connect the negative lead to the **AOUT1-** terminal. Then press **Enter** on the LOI.
Refer to [Figure 2-4](#), [Figure 2-5](#), and [Figure 2-6](#).
The LOI displays **4 mA...Meter**. The trim program inputs the design equivalent signal for a 4.00 mA output.
6. Read the O₂ milliamp output at the digital multimeter. Use **Right** to select each digit and use **Up** and **Down** to change the value. When the correct value is displayed, use **Enter** to input the value.
The LOI displays a **20 mA...Meter**. The trim program inputs the design-equivalent signal for a 20.00 mA output.
7. Read the O₂ milliamp output at the digital multimeter. Press **Right** to select each digit and press **Up** and **Down** to change the value. When the correct value is displayed, press **Enter** to input the value.
The LOI displays a **Meter at 4 mA** prompt.
8. Press **Right** to select **yes** or **no**. Press **Up** and **Down** to change the selection. Then press **Enter** to input the response. If no, the process repeats from [Step 7](#).
The LOI displays a **Meter at 20 mA** prompt.

9. Press **Right** to select **yes** or **no**. Press **Up** and **Down** to change the selection. Then press **Enter** to input the response. If **no**, the process repeats from [Step 8](#).

When the responses in [Step 8](#) and [Step 9](#) are **yes**, the trim procedure is complete.

Postrequisites

Exit the LOI menu and return the control loop to automatic control.

4.4.2 COe D/A trim using the local operator interface (LOI)

Refer to the LOI menu tree in [Figure 4-4](#).

⚠ WARNING

To avoid a potentially dangerous operating condition, remove the transmitter from the automatic combustion control loop before you start the D/A trim procedure.

Procedure

1. From the operating display, press **Left** to select the first column submenu. Press **Down** to select **SYSTEM**.
2. From the **SYSTEM** menu, press **Down** to select **Input/Output**. Press **Right** to select the **Analog** parameters list.
3. Scroll down to the item, **Trim COe Out**. Press **Right** to start the COe trim procedure.

Note

If you wish to exit D/A trim with no changes, step through the procedure using **yes** responses and enter no meter readings.

4. Remove the electronics housing cover.
5. Connect a digital multimeter to read the milliamp output from the COe D/A converter circuit. Connect the positive lead to the **AOUT2+** terminal and connect the negative lead to the **AOUT2-** terminal. Then press **Enter** on the LOI.
Refer to [Figure 2-4](#), [Figure 2-5](#), and [Figure 2-6](#).
The LOI displays **4 mA...Meter**. The trim program inputs the design equivalent signal for a 4.00 mA output.
6. Read the COe milliamp output at the digital multimeter. Press **Right** to select each digit and press **Up** and **Down** to change the value. When the correct value is displayed, press **Enter** to input the value.
The LOI displays **20 mA...Meter**. The trim program inputs the design-equivalent signal for a 20.00 mA output.
7. Read the COe milliamp output at the digital multimeter. Press **Right** to select each digit and press **Up** and **Down** to change the value. When the correct value is displayed, press **Enter** to input the value.
The LOI displays a **Meter at 4 mA** prompt (question).
8. Press **Right** to select **yes** or **no**. Press **Up** or **Down** to change the selection. Then use **Enter** to input the response.
If **no**, the process repeats from [Step 7](#). The LOI displays a **Meter at 20 mA** prompt (question).
9. Press **Right** to select **yes** or **no**. Press **Up** or **Down** to change the selection. Then use **Enter** to input the response.
If **no**, the process repeats from [Step 8](#).

When the responses in [Step 8](#) and [Step 9](#) are **yes**, the trim procedure is complete.

Postrequisites

Exit the LOI menu and return the control loop to automatic control.

5 Using HART® communications

5.1 Overview

The Field Communicator is a handheld communications interface device. It provides a common communications link to all microprocessor-based instruments that are HART® compatible.

To interface with the Rosemount OCX8800, the Field Communicator requires a termination point along the O₂ 4-20 mA current loop and a minimum load resistance of 250 ohms between the communicator and the power supply. The Field Communicator accomplishes its task using a frequency shift keying (FSK) technique. With the use of FSK, high-frequency digital communication signals are superimposed on the 4-20 mA oxygen output signal. The communicator does not disturb the 4-20 mA signal, since no net energy is added to the loop. HART information is not available on the COe output signal.

If you install special software, you may interface the Field Communicator with a personal computer (PC). You must have an interface adapter to connect the Field Communicator to a PC. Refer to the proper Field Communicator documentation in regard to the PC interface option.

5.2 Field Communicator signal connections

The Field Communicator can connect to the Rosemount OCX8800 oxygen analog output signal line at any wiring termination in the O₂ 4-20 mA current loop.

There are two methods of connecting the Field Communicator to the signal line. For applications in which the signal line has a load resistance of 250 ohms or more, refer to [Method 1: For load resistance ≥ 250 ohms](#). For applications in which the signal line load is less than 250 ohms, refer to [Method 2: For load resistance < 250 ohms](#).

5.2.1 Method 1: For load resistance ≥ 250 ohms

Figure 5-1: Signal Line connections, ≥ 250 Ohms Load Resistance

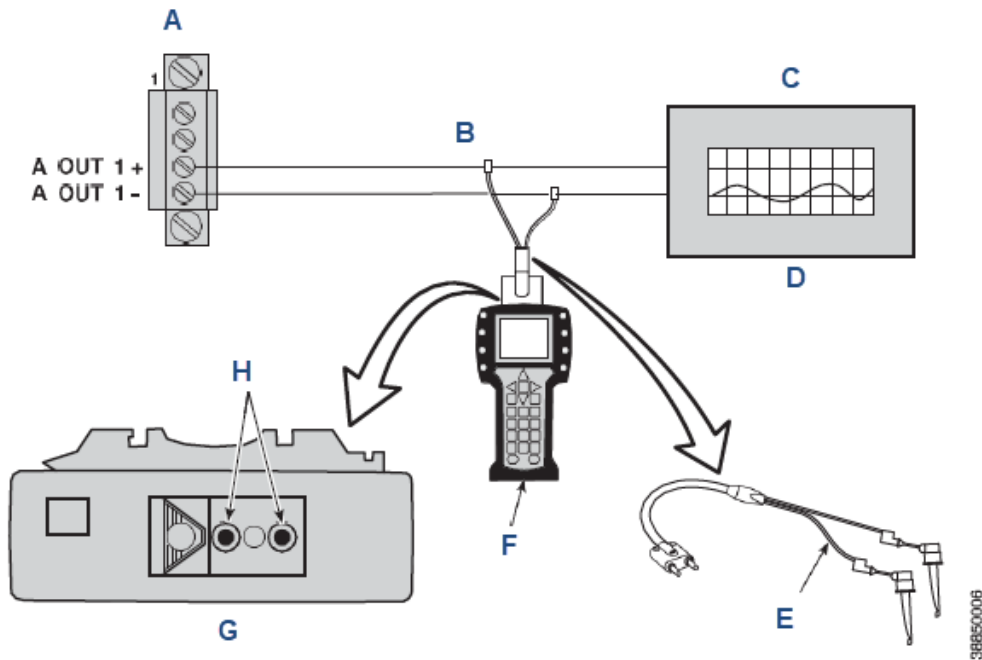

- A. 4-20 mA terminal block in electronics housing
- B. O₂ 4-20 mA signal line
- C. Load resistance $\geq 250 \Omega$
- D. Analog output device
- E. Lead set
- F. Field Communicator
- G. Field Communicator rear panel
- H. Loop connectors

⚠ WARNING

Explosions can result in death or serious injury.

Do not make connections to the Field Communicator's serial port, 4-20 mA signal lines, or NiCad recharger jack in an explosive atmosphere.

Procedure

1. Using the supplied lead set, connect the Field Communicator in parallel to the transmitter.
2. Use any wiring termination points in the analog output 4-20 mA signal line.

5.2.2 Method 2: For load resistance < 250 ohms

⚠ WARNING

Explosive atmosphere

Explosions can result in death or serious injury.

Do not make connections to the Field Communicator's serial port, 4-20 mA signal lines, or NiCad recharger jack in an explosive atmosphere.

Figure 5-2: Signal Line Connections, < 250 Ohms Load Resistance

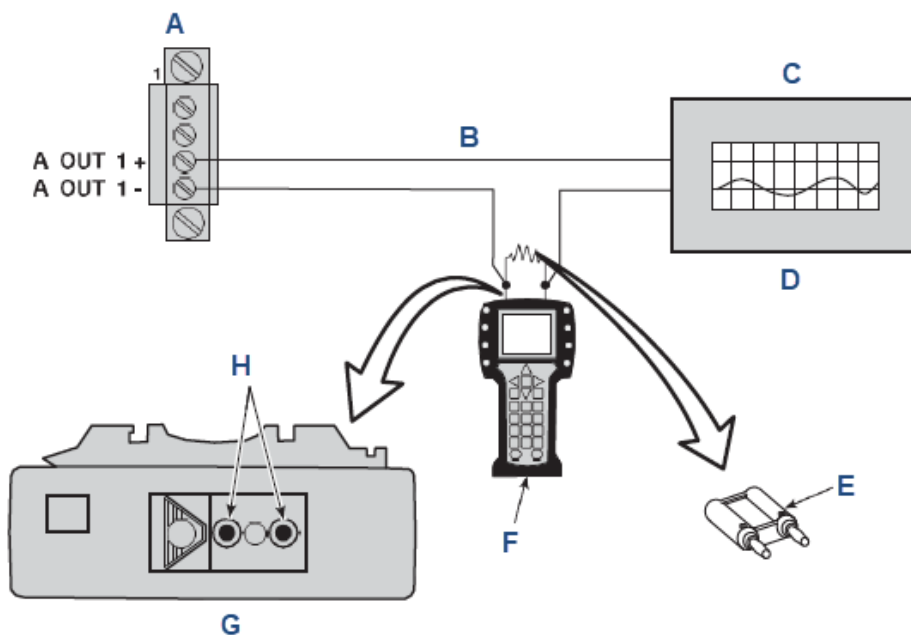

388500007

- A. 4-20 mA terminal block in electronics housing
- B. O₂ 4-20 mA signal line
- C. Load resistance < 250 Ω
- D. Analog output device
- E. 250 ohms load resistor⁽²⁾
- F. Field Communicator
- G. Field Communicator rear panel
- H. Loop connectors

Procedure

1. At a convenient point, break the analog output 4-20 mA signal line and install the optional 250 ohm load resistor.
2. Plug the load resistor into the loop connectors (located on the rear panel of the Field Communicator).

(2) Break the signal loop to insert the optional 250 ohm load resistor.

5.3 Field Communicator PC connections

There is an option to interface the Field Communicator with a personal computer.

Load the *Easy Upgrade Programming Utility* software into the PC. Then link the Field Communicator to the PC through the IRDA interface. Refer to the proper Field Communicator documentation in regard to the PC interface operation.

5.3.1 Off-line and on-line operations

You can operate the Field Communicator either off-line or on-line.

Off-line operations are those in which the Field Communicator is not connected to the Rosemount OCX8800. Off-line operations can include interfacing the Field Communicator with a PC. (Refer to applicable documentation regarding HART®/PC applications).

In the on-line mode, the Field Communicator is connected to the oxygen 4-20 mA analog output signal line. The Field Communicator is connected in parallel to the transmitter or in parallel to the 250 ohm load resistor.

The opening menu displayed on the LCD is different for on-line and off-line operations. When powering up a disconnected (off-line) Field Communicator, the LCD displays the **Main Menu**. When powering up a connected (on-line) Field Communicator, the LCD displays the **On-line Menu**. Refer to the *Field Communicator* manual for detailed menu information.

5.4 HART® menu tree

Figure 5-3 provides a menu tree for the Field Communicator, which is specific to Rosemount OCX8800 applications.

Figure 5-3: HART Menu Tree

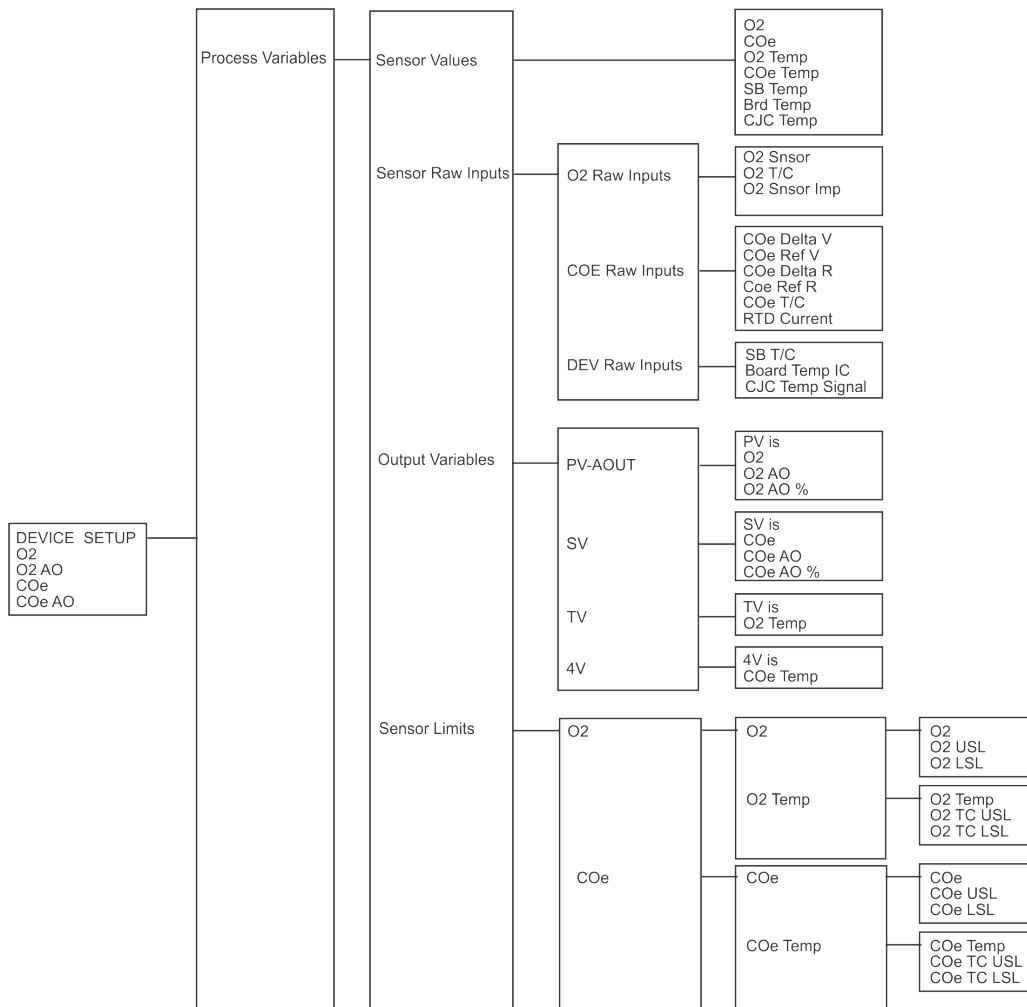

(CONTINUED ON
SHEET 2)

39930012

(CONTINUED FROM
SHEET 1)

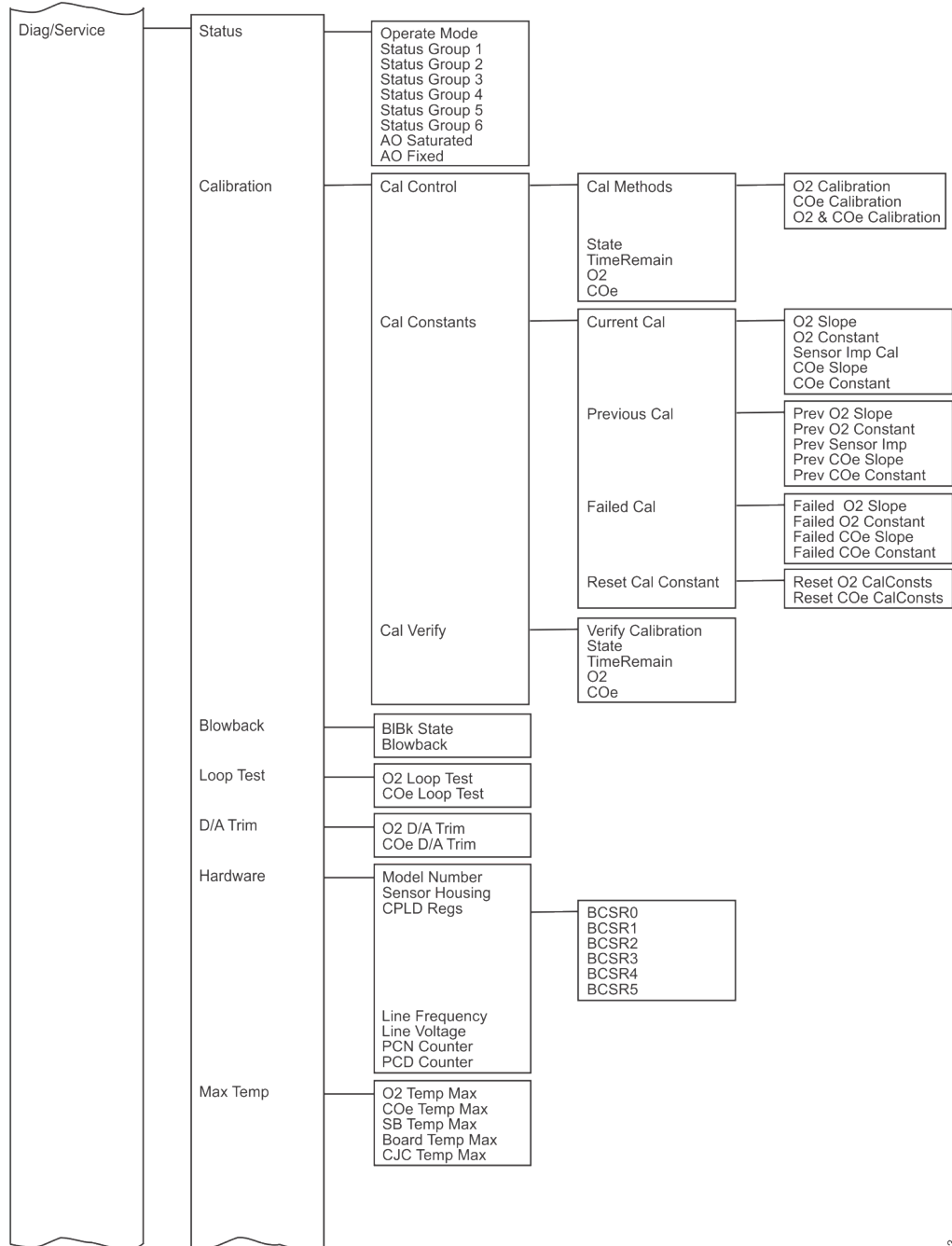

(CONTINUED ON
SHEET 3)

(CONTINUED ON
SHEET 3)

39930013

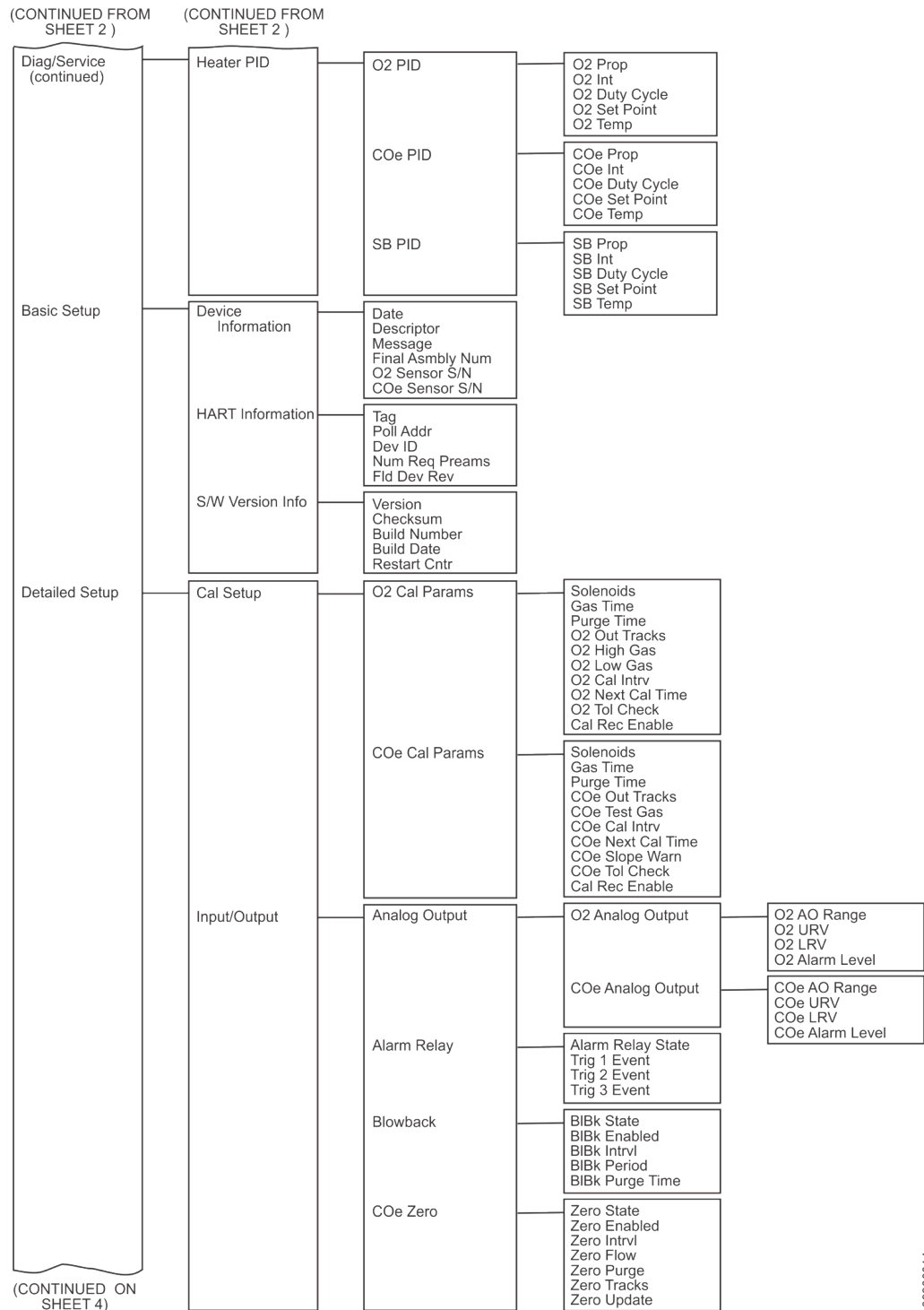

(CONTINUED FROM
SHEET 3)

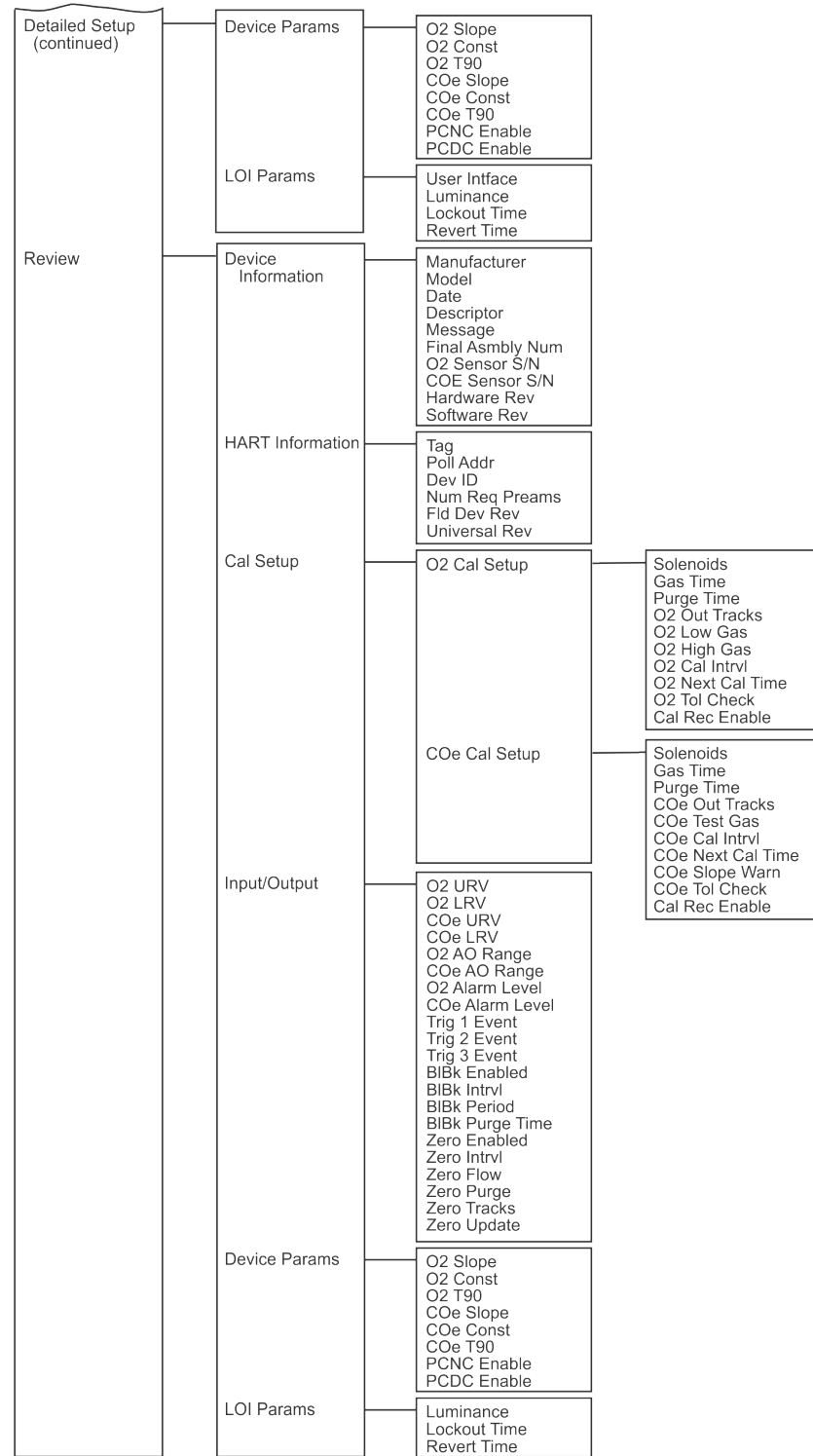

39930015

5.5 D/A trim procedures

5.5.1 O₂ D/A trim using HART®

Refer to the HART menu tree, [Figure 5-3](#).

Note

To select a menu item, either use **Up** and **Down** to scroll to the menu item and press **Right** or use the number keypad to select the menu item number.

To return to a preceding menu, press **Left**.

Procedure

1. From the **DIAG/SERVICE** menu, select **D/A TRIM**.
The Field Communicator displays **O₂ D/A Trim**.
2. Press **Right** to start the procedure.
If you wish to exit the D/A Trim with no changes, select **ABORT**.
The Field Communicator displays: **WARNING: Loop should be removed from automatic control**.
3. Remove the transmitter from any automatic control loops to avoid a potentially dangerous operating condition and press **OK**.
The Field Communicator displays **Connect reference meter to O₂ output**.
4. Remove the electronics housing cover.
5. Connect a digital multimeter to read the milliamp output from the O₂ D/A converter circuit. Connect the positive lead to the **AOUT1+** terminal and connect the negative lead to the **AOUT1-** terminal. Then press **OK** on the Field Communicator.
Refer to [Figure 2-4](#), [Figure 2-5](#), and [Figure 2-6](#).
The Field Communicator displays **Setting Fld dev output to 4 mA**.
6. Press **OK**. Read the O₂ miliamp output at the digital multimeter. Enter the reading at the Field Communicator and press **ENTER**.
Select **ABORT** to exit without changes.
The Field Communicator displays **Setting Fld dev output to 20 mA**.
7. Press **OK**. Read the O₂ miliamp output at the digital multimeter. Enter the reading at the Field Communicator and press **ENTER**.
Select **ABORT** to exit without changes.
The Field Communicator displays **Setting Fld dev output to 4 mA**.
8. Press **OK**.
The Field Communicator displays **Fld dev output 4.00 mA equal to reference meter?**
9. Using **Up** or **Down**, select **1 Yes** or **2 No** and press **ENTER**.
If **No**, the process repeats from [Step 5](#).
The Field Communicator displays **Setting Fld dev output to 20 mA**.
10. Press **OK**.
The Field Communicator displays **Fld dev output 20.00 mA equal to reference meter?**
11. Using **Up** or **Down**, select **1 Yes** or **2 No** and press **ENTER**.
If **No**, the process repeats from [Step 6](#).
The Field Communicator displays **NOTE: Loop may be returned to automatic control**.

5.5.2 COe D/A trim using HART®

If necessary, refer to [Figure 5-3](#) for the HART menu tree.

Note

To select a menu item, either use **Up** and **Down** to scroll to the menu item and press **Right** or use the number keypad to select the menu item number. To return to a preceding menu, press **Left**.

Procedure

1. From the **DIAG/SERVICE** menu, select **D/A TRIM**.
The Field Communicator displays **O₂ D/A Trim**.
2. Press **Up** or **Down** to select **COe D/A TRIM**.
3. Press **Right** to start the procedure.
If you wish to exit D/A Trim with no changes, select **ABORT**.
The Field Communicator displays **WARNING: Loop should be removed from automatic control**.
4. Remove the transmitter from any automatic control loops to avoid a potentially dangerous operating condition and press **OK**.
The Field Communicator displays **Connect reference meter to Combustibles output**.
5. Remove the electronics housing cover.
6. Connect a digital multimeter to read the milliamp output from the COe D/A converter circuit. Connect the positive lead to the **AOUT2+** terminal and connect the negative lead to the **AOUT2-** terminal. Then press **OK** on the Field Communicator.
Refer to [Figure 2-4](#), [Figure 2-5](#), and [Figure 2-6](#).
The Field Communicator displays **Setting Fld dev output to 4 mA**.
7. Press **OK**. Read the COe milliamp output at the digital multimeter. Enter the reading in the Field Communicator and press **ENTER**.
Select **ABORT** to exit without changes.
The Field Communicator displays **Setting Fld dev output to 20 mA**.
8. Press **OK**. Read the COe milliamp output at the digital multimeter. Enter the reading at the Field Communicator and press **ENTER**.
Select **ABORT** to exit without changes.
The Field Communicator displays **Setting Fld dev output to 4 mA**.
9. Press **OK**.
The Field Communicator displays **Fld dev output 4.00 mA equal to reference meter?**
10. Using **Up** or **Down**, select **1 Yes** or **2 No**. Press **ENTER**.
If **No**, the process repeats from [Step 6](#).
The Field Communicator displays **Setting Fld dev output to 20 mA**.
11. Press **OK**.
The Field Communicator displays **Fld output 20.00 mA equal to reference meter?**
12. Using **Up** or **Down**, select **1 Yes** or **2 No**. Press **ENTER**.
If **No**, the process repeats from [Step 9](#).
The Field Communicator displays **NOTE: Loop may be returned to automatic control**.

6 Calibration

6.1 Overview

During calibration, the operator applies two calibration gases with known O₂ concentrations and one calibration gas with a known CO_e concentration to the transmitter. Slope and constant values are calculated to determine if the transmitter is correctly measuring net concentration of O₂ and combustibles in the industrial process.

Before calibrating the transmitter, verify that the calibration gas parameters are correct by setting the test gas values to use when calibrating it. Refer to [Configuration and start-up](#).

There are three calibration methods available to the transmitter: automatic, operator-initiated, and manual. You can access calibration commands and menus with the Field Communicator or the optional local operator interface (LOI).

6.2 Fully automatic calibration

If the transmitter is equipped with calibration solenoids, you can program it to automatically calibrate without any operator action.

Refer to [Set up autocalibration using the local operator interface \(LOI\)](#) or [Set up autocalibration using HART®](#) to set up the transmitter for fully automatic calibration.

6.2.1 Set up autocalibration using the local operator interface (LOI)

If necessary, refer to [Figure 4-4](#) for reference. The transmitter must be equipped with calibration solenoids to use automatic calibration.

Procedure

1. From the operating display, press **Right** to select **SYSTEM** from the first column submenu.
2. From the **SYSTEM** first column submenu, press **Right** to select the **Calib Setup** second column submenu.
3. From the **Calib Setup** second column submenu, press **Right** to select the third column parameter list.
4. Scroll down to the last item, **Use Solenoids**. If the transmitter is equipped with calibration solenoids and you want timed automatic calibration, select **Yes**.
5. Press **Up** to select **O₂ Out Tracks**. Select **Yes** or **No** to determine if the transmitter will update the O₂ lock value.
6. Press **Down** key to select **CO_e Out Tracks**. Select **Yes** or **No** to determine if the transmitter will update the CO_e lock value.
7. Press **Down** to select **O₂ Cal Interval**. Enter the amount of time in days and hours that is desired between automatic calibrations.
8. Press **Down** key to select **O₂ Next Cal**. Enter the amount of time in hours until the next automatic calibration. Press **Left** three times to move back to the LOI operating display.

6.2.2 Set up autocalibration using HART®

Use the following procedure to specify a time interval (in hours) at which the transmitter will automatically calibrate.

Note

Automatic calibration is only available on transmitters equipped with calibration solenoids.

Procedure

1. From the **DEVICE SETUP** screen, select **DETAILED SETUP**.
2. From the **DETAILED SETUP** screen, select **O₂ CALIB PARAMS** or **COE CALIB PARAMS**.
3. If the transmitter is equipped with calibration solenoids and you want timed automatic calibrations, select **Solenoids**; then select **Yes**. Select **No** to disable the calibration solenoids.
4. Select **O₂ CalIntrvl** (O₂ calibration interval) and enter the desired time in hours between automatic O₂ calibrations. Select **COE CalIntrvl** and enter the desired time between automatic COe calibrations. To disable automatic calibration for O₂ and COe, enter **0** for both **CalIntrvl** parameters.

If you want, you can change the **O₂ NxtCalTm** and the **COeNxtCalTm** (next calibration time) parameters to synchronize a calibration at a specific day or time.

CAUTION

When setting automatic calibration times, set **CalIntrvl** and **NxtCalTm** so that O₂ and COe are NOT calibrated simultaneously.

Note

To select a menu item, either press **Up** and **Down** to scroll to the menu item and press **Right** or use the number keypad to select the menu item number.

To return to a preceding menu, press **Left**.

5. From the **O₂ CALIB PARAMS** screen, select **CalIntrvl** (O₂ calibration interval).
6. At the prompt, input a time interval (in hours) at which an automatic O₂ calibration will occur and press **ENTER**.
7. From the **DETAILED SETUP** screen, select **COE CALIB PARAMS**.
8. From the **COE CALIB PARAMS** menu, select **CalIntrvl**.
9. At the prompt, input a time interval (in hours) at which an automatic COe calibration will occur and press **ENTER**.

To disable automatic calibration for O₂ and COe, enter **0** for both **CalIntrvl** parameters.

6.3 Operator-initiated autocalibration

An operator can initiate an automatic calibration at any time, as long as the transmitter is equipped with calibration solenoids.

6.3.1 Autocalibrate using the optional local operator interface (LOI)

To initiate a calibration using the LOI, perform the following steps on the LOI menu tree.

Procedure

1. From the **Calibration** menu, press **Right** to select the **Cal Control** menu.
2. Select **Start Cal-O₂**, **Start Cal COe**, or **Start Cal Both** to start the calibration. Select **Cal Verify** to access the **Calibration** window.
3. At the prompt, press **Right** to initiate automatic calibration.

6.3.2 Autocalibrate using HART®

To initiate an automatic calibration using HART/AMS, perform the following steps on the HART menu tree. Refer to [Figure 5-3](#) for the HART menu tree.

Procedure

1. From the **DEVICE SETUP** menu, select **DIAG/SERVICE**.
2. From the **DIAG/SERVICE** menu, select **CALIBRATION**.
3. From the **CALIBRATION** menu, select **PERFORM CAL**.
4. From the **PERFORM CAL** menu, select **CAL METHODS**.
5. From the **CAL METHODS** menu, select the type of calibration desired: **O₂ Calibration**, **COe Calibration**, or **O₂ and COe Calibration**.

6.4 Manual calibration

If a transmitter is not equipped with calibration solenoids, an operator must calibrate by following prompts from the transmitter.

Refer to [Calibrate manually using the optional local operator interface \(LOI\)](#), [Calibrate O₂ manually using the Field Communicator: HART®](#), or [Calibrate COe manually using the Field Communicator: HART®](#).

6.4.1 Calibrate manually using the optional local operator interface (LOI)

Once the operator initiates the manual calibration procedure at the LOI, a series of prompts will appear giving instructions to the operator.

Procedure

1. Press **Right** to select the **CALIBRATION** first column submenu.
2. From the **CALIBRATION** submenu, press **Right** to select the **Cal Control** second column submenu.
3. From the **Cal Control** submenu, press **Right** to select the third column **Start Cal O₂** option.

4. Remain at **Start Cal O₂** or press **Down** to select **Start Cal COe** or **Start Cal Both**.
The following sequence applies when you select **Start Cal Both**.
5. Press **Right** to start the calibration. Turn on the low O₂ test gas, when prompted by the **Flow Low Gas** message.
6. Press **Right** after applying the low O₂ test gas.
The calibration data changes as the calibration proceeds.
7. Press **Right** when the low O₂ reading is stable. Turn off the low O₂ test gas and turn on the high O₂ test gas as prompted by the **Flow High Gas** message.
8. Press **Right** after applying the high O₂ test gas.
The calibration data changes as the calibration proceeds.
9. Press **Right** when the high O₂ reading is stable. Turn off the high O₂ test gas. Press **Right** to start the high O₂ gas purge.
When the purge period expires, the LOI display reverts to the normal operation display. If the calibration failed, the display will indicate an alarm condition.
10. Press **Right** to start combustibles calibration. Turn on the CO test gas when prompted.
11. Press **Right** after applying the CO test gas.
The calibration data changes as the calibration proceeds.
12. Press **Right** when the CO reading is stable.
13. Turn off the CO test gas and press **Right** to start the CO gas purge.
When the purge period expires, the LOI display reverts to the normal operation display. If the calibration failed, the display will indicate an alarm condition.

6.4.2 Calibrate O₂ manually using the Field Communicator: HART®

If necessary, refer to [Figure 5-3](#) for the HART menu tree.

Note

To select a menu item, either use **Up** and **Down** to scroll to the menu item and press **Right** or use the number keypad to select the menu item number.

To return to a preceding menu, press **Left**.

Procedure

1. From the **DIAG/SERVICE** menu, select **CALIBRATION**.
2. From the **CALIBRATION** menu, select **PERFORM CAL**.
3. From the **PERFORM CAL** menu, select **CAL METHODS**.
4. From the **CAL METHODS** menu, select the type of calibration desired: **O₂ Calibration**.
In the first **Calibration** screen, a **Loop should be removed from automatic control** warning appears.
5. Remove the transmitter from any automatic control loops to avoid a potentially dangerous operating condition and press **OK**.
6. Set the **Calibration** screen to the following values. Press **OK** to continue.
 - OCX: TAG NAME
 - STATUS: Idle
 - TIME REMAIN: 0s
 - O2: 0.4 %, 85.95mV
 - OK/NEXT to Select

- ABORT/CANCEL to Exit
7. From the **SELECT ACTION** screen, select **START/NEXT CALSTEP** to continue calibration, select **ABORT CAL** to abort calibration, or select **EXIT CAL** to exit calibration. Select one item from the list and press **ENTER**.
 - OCX: TAG NAME
 - SELECT ACTION
 - 1. START/NEXT CALSTEP
 - 2. ABORT CAL
 - 3. EXIT CAL
 8. When the **Calibration Status** is at the **AppO₂Low** step, switch on O₂ low gas. Verify the O₂ concentration measured matches the **O₂ LOW GAS** parameter in the **Setup** window. Press **OK** when ready.
 9. Select **START/NEXT CALSTEP** to start applying the O₂ low gas.
The time to apply the test gas is specified by the **Gas Time**.
The **Calibration Status** should be automatically changed to **FlowO₂Low** and then **ReadO₂Low** for a period of time. During this period, if you try to go to the next calibration step by pressing **OK** and selecting **START/NEXT CALSTEP**, you will be prompted with **Operator step command is not accepted at this time**. The **NEXT CALSTEP** command is not accepted at this time. When ready, **Calibration Status** will stop at the **AppO₂Hi**.
 10. Switch off the O₂ low gas and switch on the O₂ high gas. Verify the O₂ concentration measured matches the **O₂ HIGH GAS** parameter in the **Setup** window. Press **OK** when ready.
 11. Select **START/NEXT CALSTEP** to start applying the O₂ high gas.
The time to apply the test gas is specified by the **Gas Time**.
The **Calibration Status** should be automatically changed to **FlowO₂Hi** and then **ReadO₂Hi** for a period of time. During this period, if you try to go the next calibration step by pressing **OK** and selecting **START/NEXT CALSTEP**, you will be prompted with **Operator step command is not accepted at this time**. The **NEXT CALSTEP** command is not accepted at this time. When ready, Calibration Status will stop at **STOP GAS**.
 12. Switch off the O₂ high gas. Press **OK** when ready. Select **START/NEXT CALSTEP** to start purging gas.
The time to purge gas is specified by the **Purge Time**.
When the purge step is complete, the **Calibration Status** will be at **IDLE** if the calibration is successful or **CAL RECOMMENDED** if the calibration has failed. A **Calibration Failed** alarm will be set if the calibration has failed.
 13. When calibration is complete, select **Exit Cal** to exit the calibration method.

6.4.3 Calibrate CO_e manually using the Field Communicator: HART®

If necessary, refer to [Figure 5-3](#) for the HART menu tree.

Note

To select a menu item, either use **Up** and **Down** to scroll to the menu item and press **Right** or use the number keypad to select the menu item number.

To return to a preceding menu, press **Left**.

Procedure

1. From the **DIAG/SERVICE** menu, select **CALIBRATION**.
2. From the **CALIBRATION** menu, select **PERFORM CAL**.
3. From the **PERFORM CAL** menu, select **CAL METHODS**.
4. From the **CAL METHODS** menu, select the type of calibration desired: **COe Calibration**.
In the first **Calibration** screen, a **Loop should be removed from automatic control** warning appears.
5. Remove the transmitter from any automatic control loops to avoid a potentially dangerous operating condition and press **OK**.
6. Set the main **Calibration** screen to the following settings/values. Press **OK** to continue.
 - OCX: TAG NAME
 - STATUS: Idle
 - TIME REMAIN: 0s
 - COe: 0.20 ppm, 0.00 mV
 - OK/NEXT to Select
 - ABORT/CANCEL to Exit
7. From the **SELECT ACTION** screen, select **START/NEXT CALSTEP** to continue calibration, select **ABORT CAL** to abort calibration, or select **EXIT CAL** to exit calibration. Select one item from the list and press **ENTER**.

- OCX: TAG NAME
- SELECT ACTION
 - 1. START/NEXT CALSTEP
 - 2. ABORT CAL
 - 3. EXIT CAL

The transmitter samples reference air as the COe Low Gas. The **Calibration Status** should automatically change to **ReadCOeLow** for a period of time. During this period, if you try to go to the next calibration step by pressing **OK** and selecting **START/NEXT CALSTEP**, you will be prompted with **Operator step command is not accepted at this time**. The **START/NEXT CALSTEP** is not accepted at this time. When ready, **Calibration Status** will stop at **AppCOeHi**.

8. Switch on the COe high gas. Verify the COe concentration measured matches the **COe HIGH GAS** parameter in the **Setup** window. Press **OK** when ready.
9. Select **START/NEXT CALSTEP** to start applying the COe high gas.
The time to apply the test gas is specified by the **Gas Time**.
The calibration status should automatically change to **FlowCOeHi** and then **ReadCOeHi** for a period of time. During this period, if you try to go to the next calibration step by pressing **OK** and selecting **START/NEXT CALSTEP**, you will be prompted with **Operator step command is not accepted at this time**. The **START/NEXT CALSTEP** command is not accepted at this time. When ready, Calibration Status will stop at **STOP GAS**.
10. Switch off the COe high gas. Press **OK** when ready. Select **START/NEXT CALSTEP** to start purging gas.
The time to purge gas is specified by the **Purge time**.

When the purge step is complete, the **Calibration Status** will be at **IDLE** if the calibration is successful or **CAL RECOMMENDED** if the calibration has failed.. A **Calibration Failed** alarm will be set if the calibration has failed.

11. When calibration is complete, select **Exit Cal** to exit the calibration method.

6.4.4 Calibrate O₂ and CO_e manually using the Field Communicator: HART®

To perform a manual O₂ and CO_e calibration using the Field Communicator or AMS, use the following procedure.

Note

To select a menu item, use either **Up** or **Down** to scroll to the menu item and press **Right** or use the number keypad to select the menu item number.

To return to a preceding menu, press the **Left**.

Procedure

1. Select **CALIBRATION** from the **DIAG/SERVICE** menu.
2. Select **PERFORM CAL** from the **CALIBRATION** menu.
3. Select **CAL METHODS** from the **PERFORM CAL** menu.
4. From the **CAL METHODS** menu, select the type of calibration desired: **O2 and COe Calibration**.
In the first **Calibration** screen, a **Loop should be removed from automatic control** warning appears.
5. Remove the transmitter from any automatic control loops to avoid a potentially dangerous operating condition and press **OK**.
6. Set the main **Calibration** screen to the following values. Press **OK** to continue.
 - OCX: TAG NAME
 - STATUS: Idle
 - TIME REMAIN: 0s
 - O2: 0.4%, 85.95 mV
 - COe: 0.20 ppm, 0.00 mV
 - OK/NEXT to Select
 - ABORT/CANCEL to Exit
7. From the **SELECT ACTION** screen, select **START/NEXT CALSTEP** to continue calibration, select **ABORT CAL** to abort calibration, or select **EXIT CAL** to exit calibration. Select one from the list and press **ENTER**.
 - OCX: TAG NAME
 - SELECT ACTION
 - 1. START CAL/NEXT CALSTEP
 - 2. ABORT CAL
 - 3. EXIT CAL
8. When the **Calibration Status** is at the **AppO2Low** step, switch on O₂ low gas. Verify the O₂ concentration measured matches the **O2 LOW GAS** parameter in **Setup**. Press **OK** when ready.

9. Select **START/NEXT CALSTEP** to start applying the O₂ low gas.
The time to apply the test gas is specified by the **Gas Time**.
The **Calibration Status** should automatically change to **FIowO2Low** and then **ReadO2Low** for a period of time. During this period, if you try to go to the next calibration step by pressing **OK** and selecting **START/NEXT CALSTEP**, you will be prompted with **Operator step command is not accepted at this time**. The **START/NEXT CALSTEP** command is not accepted at this time. When ready, **Calibration Status** will stop at **AppO2Hi**.
10. Switch off the O₂ low gas and switch on the O₂ high gas. Verify the O₂ concentration measured matches the **O2 HIGH GAS** parameter in **Setup**. Press **OK** when ready.
11. Select **START/NEXT CALSTEP** to apply the O₂ high gas.
The time to apply the test gas is specified by the **Gas Time**.
The **Calibration Status** should automatically change to **FIowO2Hi**, **ReadO2Hi**, and then **ReadCOeLo** for a period of time. During this period, if you try to go to the next calibration step by pressing **OK** and selecting **START/NEXT CALSTEP**, you will be prompted with **Operator step command is not accepted at this time**. The **START/NEXT CALSTEP** command is not accepted at this time. When ready, **Calibration Status** will stop at **AppCOeHi**.
12. Switch off the O₂high gas and switch on the COe Gas. Verify the COe concentration measured matches the **COe TEST GAS** parameter in the Setup. Press **OK** when ready.
13. Select **START/NEXT CALSTEP** to start applying the COe gas. The time to apply the test gas is specified by the **Gas Time**.
The **Calibration Status** should automatically change to **FIowCOeHi** and then **ReadCOeHi** for a period of time. During this period, if you try to go to the next calibration step by pressing **OK** and selecting **START/NEXT CALSTEP**, you will be prompted with **Operator step command is not accepted at this time**. The **START/NEXT CALSTEP** command is not accepted at this time. When ready, **Calibration Status** will stop at **STOP GAS**.
14. Switch off the COe gas. Press **OK** when ready. Select **START/NEXT CALSTEP** to start purging gas.
The time to apply the test gas is specified by the **Purge Time**.

6.4.5 Calibrate O₂/COe manually using the Field Communicator - FOUNDATION™ Fieldbus

Note

To select a menu item, either use the **Up** and **Down** arrow keys to scroll to the menu item and press the **Right** key or use the number keypad to select the menu item number. To return to a preceding menu, press the **Left** key.

Procedure

1. To calibrate from Fieldbus, first set the Transducer Block to Out of Service Mode (OOS).
2. To set the OOS mode, select **Transducer**; then select **Process**, followed by **Out of Service** on the **Target Mode** screen.
3. From the **Transducer** screen, select **Methods**.
4. From the **Methods** screen, select **OCX Calibration**.
5. From the **OCX Calibration** screen, select Calibrate O₂ Sensor for O₂ calibration, select **Calibrate Combustibles Sensor** for COe calibration, or select **Calibrate Both Sensors** if you want to calibrate both sensors.

On the **Calibration** screen, a Loop should be removed from automatic control warning appears.

6. Remove the device from any automatic control loops to avoid a potentially dangerous operating condition and press **OK**.
7. Set the **Select Action** screen to the following values/settings. From the **Select Action** screen, select **Update Display** to refresh the calibration status, select **Next Calibration Step** to continue calibration, select **Abort Calibration** to abort calibration, or select **Exit** to exit calibration. Select one item from the list and press **OK**.
The **Select Action** screen is static and data will not be automatically refreshed.
 - Calibration Step: Idle
 - Step Time Remaining: 0 seconds
 - O₂ Value: 0.40 %
 - Combustibles Value: 1000 ppm
 - Update Display
 - Next Calibration Step
 - Abort Calibration/Exit
8. Set the **Calibration** screen to the following values/settings; press **OK** to continue. The **Calibration** screen should automatically refresh, however it may take a while for the data to refresh.
 - Calibration Step: Apply O₂ Low Gas
 - Step Time Remaining: 0 seconds
 - O₂ Value: 0.40 %
 - Combustibles Value: 1000 ppm
 - Press Next for Selection
9. When the calibration status is at the Apply O₂ Low Gas/Apply Comb Low Gas step, switch on O₂ Low Gas/COe Low Gas. Verify the O₂ concentration measured matches the O₂ Low Gas parameter in the setup. The unit samples reference air as the COe Low Gas. Press **OK** when ready.
10. Select **Next Calibration Step** and press **OK** to start applying the test gas.
The time to apply the test gas is specified by the Gas Time.
The calibration step will change to Flow O₂ Low Gas/Flow Comb Low Gas and then Read O₂ Low Gas/Read Comb Low Gas for a period of time. When ready, Calibration Step will stop at the Apply O₂ High Gas/Apply Comb High Gas.
11. Switch off the O₂ low gas/sample reference air and switch on the O₂ high gas/combustibles test gas. Verify the O₂/COe concentration measured matches the O₂ High Gas/COe Test Gas parameter in the setup. Press **OK** when ready.
12. Select **Next Calibration Step** to start applying the test gas.
The time to apply the test gas is specified by the Gas Time.
The calibration step will change to Flow O₂ High Gas/Flow Comb High Gas and then Read O₂ High Gas/Read Comb High Gas for a period of time.
13. Skip over to [Step 16](#) if executing Calibrate O₂ Sensor or Calibrate Combustibles Sensor.
The calibration step will change to Read Comb Low Gas for a period of time. When ready, Calibration Step will stop at Apply Comb High Gas.

14. Switch off the O₂ high gas and switch on the COe test gas. Verify the COe concentration measured matches the **COe Test Gas** parameter in the setup.
15. Select **Next Calibration Step** to start applying the test gas.
The time to apply the test gas is specified by the Gas Time.
The calibration step will change to Flow Comb High Gas and then Read Comb High Gas for a period of time. When ready, Calibration Step will stop at Stop Gas.
16. Switch off the O₂ high gas/COe test gas. Press **OK** when ready. Select **Next Calibration Step** to start purging gas.
The time to purge gas is specified by the Purge Time.
When the Purge step is complete, the Calibration Step will be at Idle. The Calibration Failed alarm will be set if the calibration has failed.
17. When calibration is complete, select **Exit** to exit the calibration method.

7 Field Communicator

7.1 Overview

The Field Communicator is a communication interface device. It supports HART® and FOUNDATION™ Fieldbus devices, letting you configure and troubleshoot in the field.

The Field Communicator includes an LCD with touch-screen display and keypad. Use the touch-screen or keypad to enter data into the Field Communicator.

Three terminals for the lead are on the top of the Field Communicator. The lead set and terminals let you connect the Field Communicator to a device. An access door ensures only one pair of terminals can be used at any time. Several markings indicate which pair of terminals is for which protocol. **F** indicates the FOUNDATION Fieldbus protocol, while **H** indicates the HART protocol.

The infrared port (IrDA) lets the Field Communicator interface with the PC. IrDA is a PC interface supported for transfer of device descriptions (DD), software updates, configurations, and application licenses. IrDA communications can either be built into the PC or provided through a USB to IrDA adapter. The PC application can either be *AMS Suite* or *Easy Upgrade Programming Utility*. The Field Communicator must be in the Listen for PC mode when communicating through IrDA.

Refer to the Field Communicator User Manual for details.

7.2 Field Communicator connections

7.2.1 Connecting to a HART® loop

Connect the Field Communicator with the supplied lead set in parallel with the device or load resistor, [Figure 7-1](#). The HART connections are not polarity sensitive. A minimum 250 ohms resistance must be present in the HART loop for the Field Communicator to function properly.

⚠ WARNING

EXPLOSION

Explosions can result in death or serious injury.

Do not make connections to the Field Communicator's serial port, digital signal line, or NiCad recharger jack in an explosive atmosphere.

Figure 7-1: Field Communicator Connections - HART

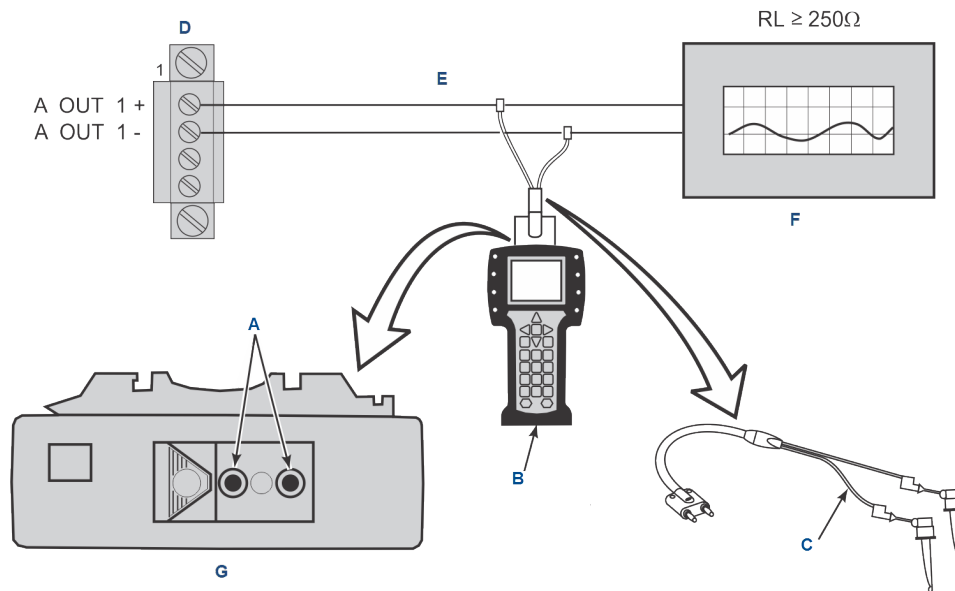

- A. Loop connectors
- B. Field Communicator
- C. Lead set
- D. 4-20 mA terminal block in electronics housing
- E. O₂ 4-20 mA signal line
- F. Analog output device
- G. Field Communicator rear panel

7.2.2 Connecting to a FOUNDATION™ Fieldbus segment

Connect the Field Communicator with the supplied lead set in parallel with the device to a Fieldbus segment, [Figure 7-2](#). The Field Communicator Fieldbus connections are polarity sensitive; an error message displays if the device is connected incorrectly.

⚠ WARNING

EXPLOSION

Explosions can result in death or serious injury.

Do not make connections to the Field Communicator's serial port, digital signal line, or NiCad recharger jack in an explosive atmosphere.

Figure 7-2: 375 Communicator connections - Fieldbus

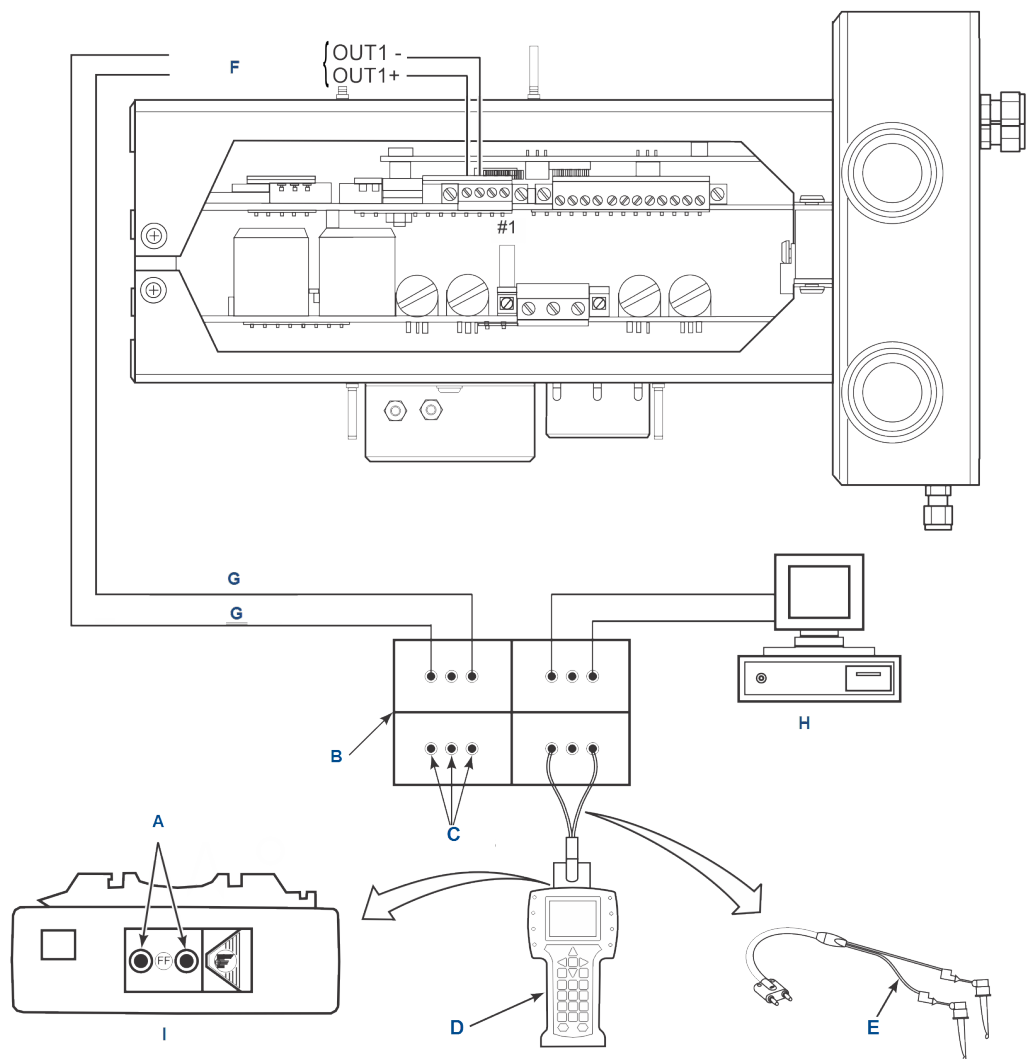

- A. Terminal connectors
- B. Terminal block
- C. Terminals
- D. Field Communicator
- E. Lead set
- F. Fieldbus signal
- G. Fieldbus digital signal
- H. Fieldbus computer terminal (PC)
- I. Field Communicator rear panel

Note
Devices shown are not to scale.

7.3 Fieldbus menu tree

[Figure 7-3](#) displays menu for the Field Communicator using the Fieldbus protocol. This menu is specific to the Hazardous Area Rosemount OCX8800 applications.

Refer to the Fieldbus parameter descriptions for the applicable range, units, and description for the Fieldbus menu parameters.

Figure 7-3: Fieldbus Menu Tree

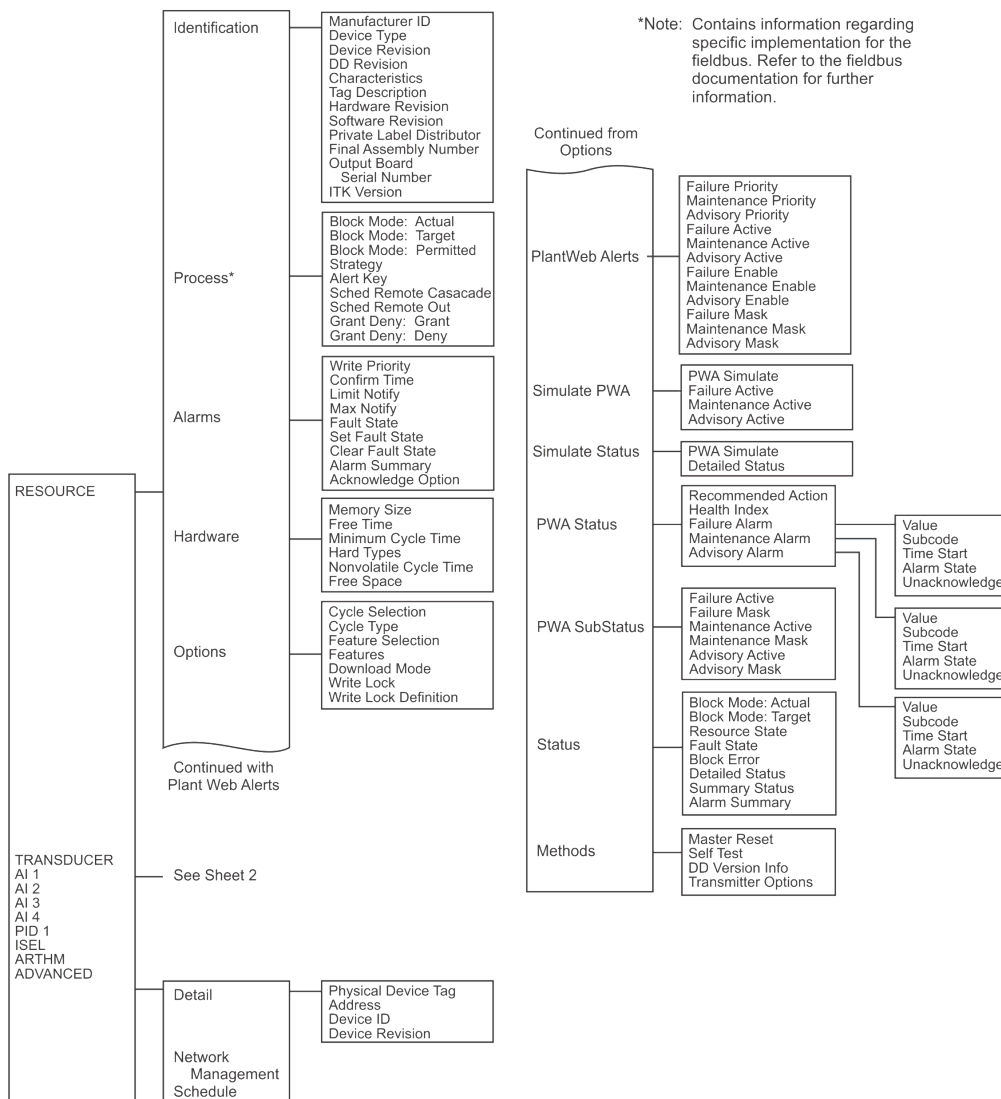

39530009

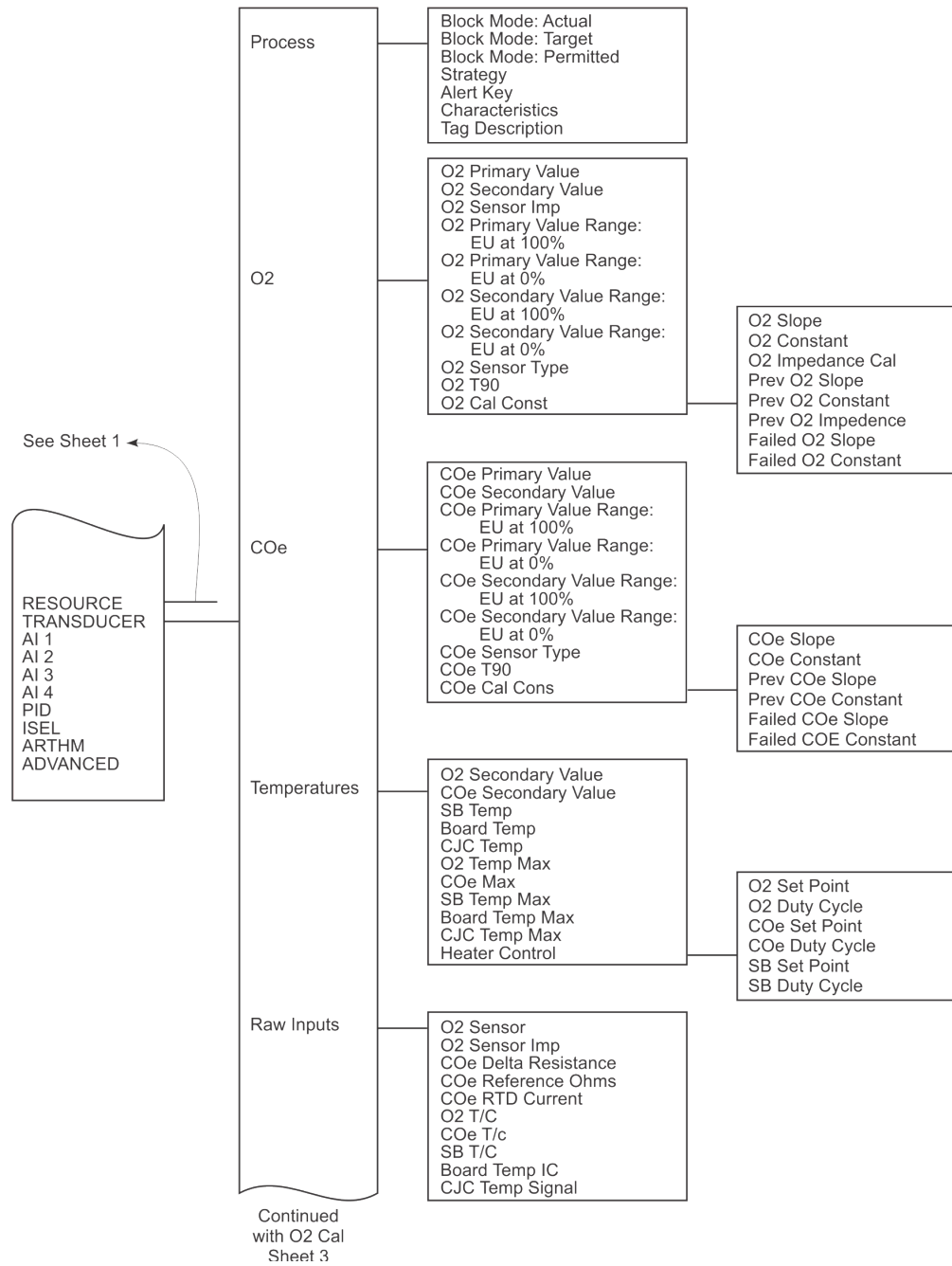

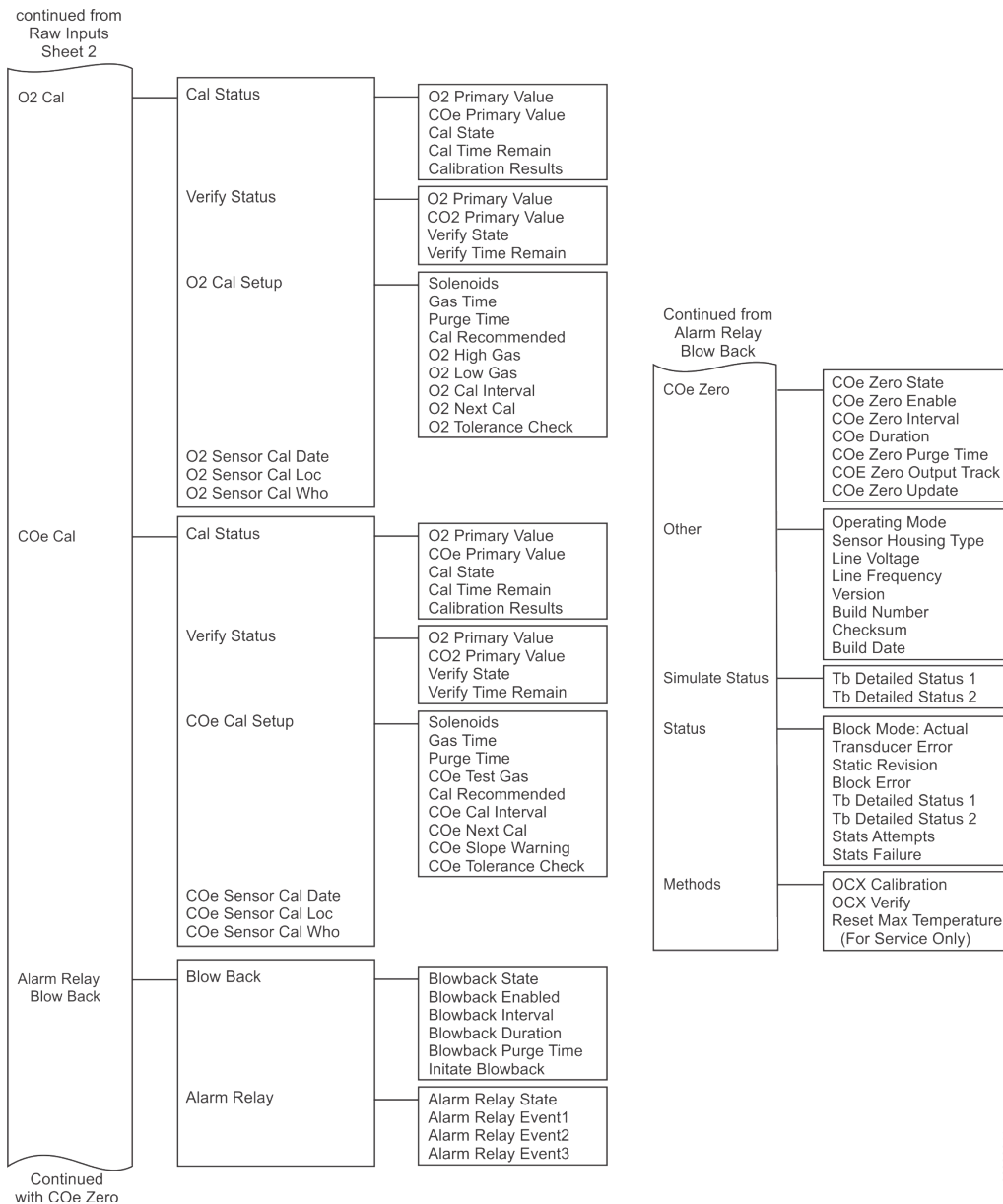

8 FOUNDATION™ Fieldbus

8.1 FOUNDATION™ Fieldbus technology

8.1.1 Overview

FOUNDATION™ Fieldbus is an all digital, serial, two-way communication system that interconnects field equipment, such as sensors, actuators, and controllers. Fieldbus is a local area network (LAN) for instruments used in both process and manufacturing automation with built-in capacity to distribute the control application across the network. It can distribute control among intelligent field devices on the plant floor and digitally communicate that information at high speed that makes FOUNDATION Fieldbus an enabling technology.

Emerson offers a full range of products from field devices to the DeltaV scalable control system to allow an easy transition to Fieldbus technology.

The Fieldbus retains the features of the 4-20 mA analog system, including standardized physical interface to the wire, bus powered devices on a single wire, and intrinsic safety options, and enables additional capabilities such as:

- Increased capabilities due to full digital communications.
- Reduced wiring and wire terminations due to multiple devices on one set of wires.
- Increased selection of suppliers due to interoperability.
- Reduced loading on control room equipment with the distribution of some control and input/output functions to field devices.
- Speed options for process control and manufacturing applications.

Note

The following descriptions and definitions are not intended as a training guide for FOUNDATION Fieldbus technology, but are presented as an overview for those not familiar with Fieldbus and to define device specific attributes for the Fieldbus system engineer. Anyone attempting to implement Fieldbus communications and control with this transmitter must be well-versed in Fieldbus technology and protocol and must be competent in programming using available tools, such as DeltaV.

8.1.2 Introduction

A Fieldbus system is a distributed system composed of field devices and control and monitoring equipment integrated into the physical environment of a plant or factory.

Fieldbus devices work together to provide I/O and control for automated process and operations. The Fieldbus Foundation provides a framework for describing these systems as a collection of physical devices interconnected by a Fieldbus network. One of the ways that the physical devices are used is to perform their portion of the total system operation by implementing one or more function blocks.

8.1.3 Function blocks

Function blocks within the Fieldbus device perform the various functions required for process control. Because each system is different, the mix and configuration of functions

are different. Therefore, the Fieldbus Foundation has designed a range of function blocks, each addressing a different need.

Function blocks perform process control functions, such as analog input (AI) and analog output (AO) functions as well as proportional-integral-derivative (PID) functions. The standard function blocks provide a common structure for defining function block inputs, outputs, control parameters, events, alarms, and modes and combine them into a process that can be implemented within a single device or over the Fieldbus network. This simplifies the identification of characteristics that are common to function blocks.

The Fieldbus Foundation has established the function blocks by defining a small set of parameters used in a function blocks called universal parameters. The Foundation has also defined a standard set of function block classes, such as input, output, control, and calculation blocks. Each of these classes also has a small set of parameters established for it. They have also published definitions for transducer blocks commonly used with standard function blocks. Examples include temperature, pressure, level, and flow transducer blocks.

The Foundation specifications and definitions allow vendors to add their own parameters by importing and subclassing specified classes. This approach permits extending function block definitions as new requirements are discovered and as technology advances.

Figure 8-1 illustrates the internal structure of a function block. When execution begins, input parameter values from other blocks are snapped-in by the block. The input snap process ensures that these values do not change during the block execution. New values received for these parameters do not affect the snapped values and will not be used by the function block during the current execution.

Figure 8-1: Function Block Internal Structure

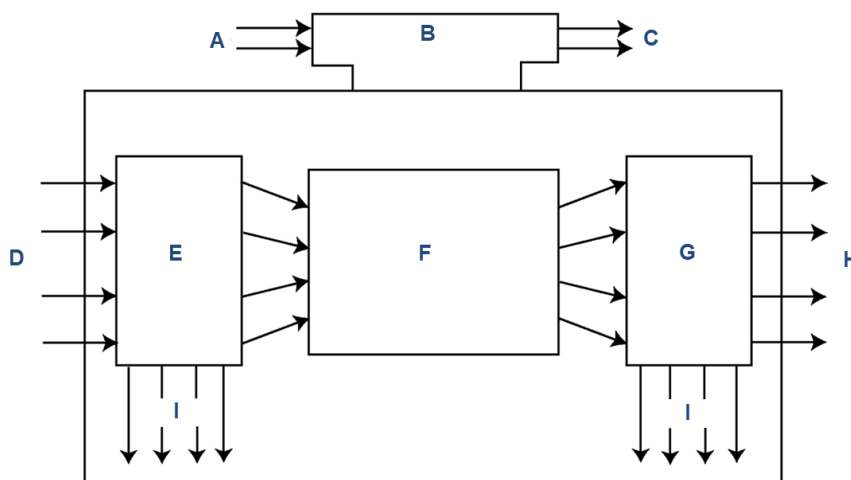

- A. Input events
- B. Execution control
- C. Output events
- D. Input parameter linkages
- E. Input snap
- F. Processing algorithm
- G. Output snap
- H. Output parameter linkages
- I. Status

39930016

Once the inputs are snapped, the algorithm operates on them, generating outputs as it progresses. Algorithm executions are controlled through the setting of contained parameters. Contained parameters are external to function blocks and do not appear as normal input and output parameters. However, they may be accessed and modified remotely, as specified by the function block.

Input events may affect the operation of the algorithm. An execution control function regulates the receipt of input events and the generation of output events during execution of the algorithm. Upon completion of the algorithm, the data internal to the block is saved for use in the next execution, and the output data is snapped, releasing it for use by other function blocks.

A block is a tagged logical processing unit. The tag is the name of the block. System management services locate a block by its tag. Thus, the service personnel need only know the tag of the block to access or change the appropriate block parameters.

Function blocks are also capable of performing short-term data collection and storage for reviewing their behavior.

8.1.4 Device descriptions

Device descriptions are specified tool definitions that are associated with the function blocks. Device descriptions provide for the definition and description of the function blocks and their parameters.

To promote consistency of definition and understanding, descriptive information, such as data type and length, is maintained in the device description. Device descriptions are written using an open language called the Device Description Language (DDL). Parameter transfers between function blocks can be easily verified, because all parameters are described using the same language. Once written, the device description can be stored on an external medium, such as a CD-ROM or diskette. You can then read the device description from the external medium. The use of an open language in the device description permits interoperability of function blocks within devices from various vendors. Additionally, human interface devices, such as operator consoles and computers, do not have to be programmed specifically for each type of device on the bus. Instead, their displays and interactions with devices are driven from the device descriptions.

Device descriptions may also include a set of processing routines called methods. Methods provide a procedure for accessing and manipulating parameters within a device.

8.1.5 Instrument-specific function blocks

In addition to function blocks, Fieldbus contains two other block types to support the function blocks. These are the resource block and the transducer block.

The resource block contains the hardware specific characteristics associated with a device. Transducer blocks couple the function blocks to local input/output functions.

Resource blocks

Resource blocks contain the hardware specific characteristics associated with a device; they have no input or output parameters.

The algorithm within a resource block monitors and controls the general operation of the physical device hardware. The execution of this algorithm is dependent on the characteristics of the physical device, as defined by the manufacturer. As a result of this activity, the algorithm may cause the generation of events. There is only one resource block defined for a device. For example, when the mode of a resource block is *out of service*, it impacts all of the other blocks.

Transducer blocks

Transducer blocks connect function blocks to local input/output functions.

They read sensor hardware and write to effector (actuator) hardware. This permits the transducer block to execute as frequently as necessary to obtain good data from sensors and ensure proper writes to the actuator without burdening the function blocks that use the data. The transducer block also isolates the function block from the vendor specific characteristics of the physical I/O.

Alerts

When an alert occurs, execution control sends an event notification and waits a specified period of time for an acknowledgement to be received.

This occurs even if the condition that caused the alert no longer exists. If acknowledgement is not received within the pre-specified time-out period, the event notification is retransmitted. This assures that alert messages are not lost.

Two types of alerts are defined for the block: events and alarms. Events are used to report a status change when a block leaves a particular state, such as when a parameter crosses a threshold. Alarms not only report a status change when a block leaves a particular state, but also report when it returns back to that state.

8.2 Network communication

Figure 8-2 illustrates a simple Fieldbus network consisting of a single segment (link).

Figure 8-2: Single Link Fieldbus Network

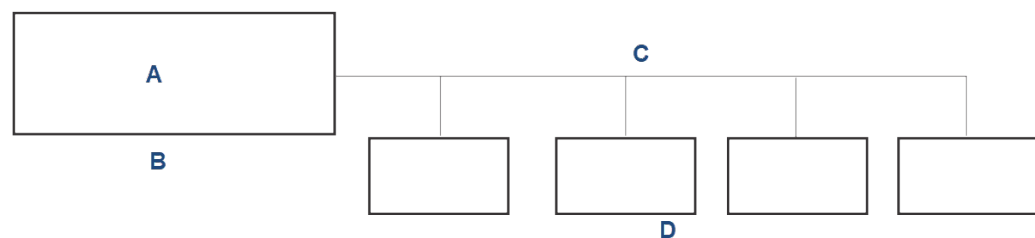

- A. LAS (link active scheduler)
- B. Link master
- C. Fieldbus link
- D. Basic devices and/or LinkMaster devices

8.2.1 Link active scheduler (LAS)

All links have one and only one link active scheduler (LAS). The LAS operates as the arbiter for the link.

The LAS does the following:

- Recognizes and adds new devices to the link.
- Removes non-responsive devices from the link.
- Distributes data link (DL) and link scheduling (LS) time on the link. Data link time is a network-wide time periodically distributed by the LAS to synchronize all device blocks on the bus. Link scheduling time is a link-specific time represented as an offset from data link time. It is used to indicate when the LAS on each link begins and repeats its schedule. It is used by system management to synchronize function block execution with the data transfers scheduled by the LAS.
- Polls devices for process loop data at scheduled transmission times.
- Distributes a priority-driven token to devices between scheduled transmissions.

Any device on the link may become the LAS, as long as it is capable. The devices that are capable of becoming the LAS are called link master devices. All other devices are referred to as basic devices. When a segment first starts up or upon failure of the existing LAS, the link master devices on the segment bid to become the LAS. The link master that wins the bid begins operating as the LAS immediately upon completion of the bidding process. Link masters that do not become the LAS act as basic devices. However, the link masters can act as LAS backups by monitoring the link for failure of the LAS and then bidding to become the LAS when an LAS failure is detected.

Only one device can communicate at a time. Permission to communicate on the bus is controlled by a centralized token passed between devices by the LAS. Only the device with the token can communicate. The LAS maintains a list of all devices that need access to the bus. This list is called the *Live List*.

Two types of tokens are used by the LAS. The LAS sends a time-critical token, compel data (CD) according to a schedule. The LAS also sends a non-time critical token, pass token (PT) to each device in ascending numerical order according to address.

8.2.2 Device addressing

Fieldbus uses addresses between 0 and 255.

Addresses 0 through 15 are reserved for group addressing and for use by the data link layer. For all Emerson Fieldbus devices, addresses 20 through 35 are available to the device. If there are two or more devices with the same address, the first device to start uses its programmed address. Each of the other devices is given one of four temporary addresses between 248 and 251. If a temporary address is not available, the device is unavailable until a temporary address becomes available.

8.3 Rosemount OCX8800 function blocks

8.3.1 Implemented function blocks

Table 8-1 shows the Rosemount OCX8800 implemented function blocks.

Table 8-1: Rosemount OCX8800 Implemented Function Blocks

Function block	Description
Resource block	N/A
Transducer block	N/A
Analog input block 1 (AI1)	See TB Channel Assignment, Table 8-18
Analog input block 2 (AI2)	See TB Channel Assignment, Table 8-18
Analog input block 3 (AI3)	See TB Channel Assignment, Table 8-18
Analog input block 4 (AI4)	See TB Channel Assignment, Table 8-18
PID block (PID)	Proportional/integral/derivative of any AI block
Arithmetic block (ARTHM)	Arithmetic function block
Input selector block (ISEL)	Input selector function block

8.4 Resource block

8.4.1 PlantWeb Alerts

The PlantWeb Alerts (PWA) software supports three groups of alarms for three severity levels: 1. Failed, 2. Maintenance, and 3. Advisory.

Each PWA can be configured for one or more of the three alarm groups. The PWA alarms and their severity level default settings are listed in [Table 8-2](#).

Table 8-2: Hazardous Area Rosemount OCX8800 PlantWeb Alerts

PlantWeb alert	Severity level default
Reserved	None
Sensor Malfunction	Failed
Sensor Degraded	Failed
Thermocouple Malfunction	Failed
Sensor Heater Malfunction	Failed
Sensor Heater Over Temperature	Failed
Sensor Heater Temperature Variance	Maintenance
Calibration Error	Maintenance
Calibration Recommended	Advisory
NV Memory Failure	Failed
NV Writes Deferred	Advisory
High Electronics Temperature	Maintenance
ADC Failure	Failed
Line Input Out of Range	Advisory
Inter Board Comm Failure	Failed
Simulate Active	Advisory

Each alarm condition must be Enabled, Disabled, or have alarm reporting Suppressed. The PWA alarms must be Enabled to allow the corresponding alarm conditions to be detected. The PWA alarms can be Suppressed to mask out failures from annunciation.

Sensor Malfunction

The **Sensor Alerts** tab displays one of the following alerts:

- O₂ Cell Open
- Comb Cell Error

This alert is active when the sensor is indicating a very high or unexpected output.

Potential causes

1. The oxygen cell interface is designed to indicate a very high output if the cell becomes disconnected from the electronics. It is possible that a wire connection, either in the probe or at the electronics, is loose or broken. The cell may also be damaged from mechanical stress. In extreme cases, a very low oxygen concentration may cause this alarm. Diagnose at the transmitter. Refer to [Diagnostic alarms](#) for details.
2. This problem could be caused by a mechanical failure in the sensor housing or at the electronics. An open circuit in the combustible sensor could also cause this alarm. Refer to [Diagnostic alarms](#) for details.

Recommended action

Check sensor wires for loose or broken connections or replace the cell.

Sensor Degraded

The **Sensor Alerts** tab displays Transducer block: O₂ Cell Impedance High.

This alert is active when the oxygen sensor indicates that the cell is beyond its useful life.

Potential cause

Oxygen cells degrade over time due to aging and corrosion. An increasing cell resistance is a good indicator of reduced cell performance. As the cell impedance increases, the cell output falls off, and response time increases. Calibrating the transmitter compensates for the increased cell resistance up to several hundred ohms, beyond which the cell is no longer functional. Diagnose at the transmitter. Refer to [Diagnostic alarms](#) for details.

Recommended action

Replace the oxygen cell.

Thermocouple Malfunction

The **T/C Heater Alerts** tab may display one of the following alarms:

1. O₂ T/C Open
2. O₂ T/C Shorted
3. O₂ T/C Reversed
4. Comb T/C Open
5. Comb T/C Shorted
6. Comb T/C Reversed
7. S/B T/C Open

8. S/B T/C Shorted
9. S/B T/C Reversed

This alert indicates a miswired or faulty thermocouple.

Potential cause

When the heater thermocouple alarms are initiated, they diagnose one of three states:

1. Open
2. Shorted
3. Reversed

The problem could be caused by a mechanical failure in the probe tip or at the electronics. Cycle power to the transmitter to resume operation. Diagnose at the transmitter. Refer to [Diagnostic alarms](#) for details.

Recommended action

Check the thermocouple wires for loose or broken connections, a short circuit condition, or a reverse wire condition.

Sensor Heater Malfunction

The **T/C Heater Alerts** tab displays one of the following alarms:

1. O₂ Heater Failure
2. Comb Heater Failure
3. SB Heater Failure
4. O₂ Heater Ramp Rate Exceeded
5. Comb Heater Ramp Rate Exceeded
6. SB Heater Ramp Rate Exceeded
7. Heater Relay Failed

This alert indicates that no measurable heat energy is being detected at the oxygen sensor or that the heater temperature is rising too fast.

Potential cause

Mechanical or thermal stress may eventually cause the heater to fail. The resistance of a properly functioning cell heater measures less than 100 ohms. A failed heater generally measures an open circuit. Diagnose at the transmitter. Refer to [Diagnostic alarms](#) for details.

The Heater Ramp Rate Exceeded problem is usually caused by the inability of the transmitter to limit power to the heater. This could be caused by a shorted triac component in the power supply in the electronics stack. Diagnose at the transmitter. Refer to [Diagnostic alarms](#) for details.

Recommended actions

1. Check heater circuit for loose or broken connections.
2. Check thermocouple wiring.
3. Test or replace the heater.

Sensor Heater Over Temperature

The **T/C Heater Alerts** tab displays one of the following alarms:

1. O₂ Cell Temp. Very High
2. Comb. Temp Very High
3. SB Temp. Very High

This alert indicates a very high heater temperature; temperature is rising too fast.

Potential cause

A heater over-temperature/out of control problem is generally caused by the inability of the transmitter to limit power to the heater. This could be caused by a shorted triac on the power supply in the electronics stack.

Recommended actions

1. Check heater wiring.
2. Check thermocouple wiring.
3. Replace the electronics stack.

Sensor Heater Temperature Variance

The following alarms may display on the **T/C Heater Alerts** tab:

1. O₂ Cell Temp. Low
2. O₂ Cell Temp. High
3. Comb. Temp. Low
4. Comb. Temp. High
5. SB Temp. Low
6. SB. Temp. High

This alert indicates a sensor heater temperature that is too high or too low.

Potential causes

Cell temperature may become erratic for the following reasons:

1. Temperature is settling during start-up.
2. There are large variations in process temperature or flow.
3. There are fluctuations or noise in the power supplied to the transmitter.

Recommended actions

1. Allow the transmitter several minutes to reach proper temperature.
2. Check power supply.

Calibration Error

The **Calibration Alerts** tab may display the following alarms:

1. O₂ Calibration Failed
2. Comb Calibration Failed
3. Calibration Warning

This alert indicates that the slope and constant values determined from the calibration did not fall within an acceptable range.

Potential cause

If you have calibrated the transmitter correctly, this alarm may indicate that you need to replace the sensor. Refer to [Diagnostic alarms](#) for details.

Recommended action

Check the calibration gas supplies and connections. Make sure the oxygen concentrations of the calibration gases match the concentration values in the transmitter.

Calibration Recommended

The **Calibration Alerts** tab may display `Calibration Recommended`. This alert indicates that the sensor resistance has changed by a predetermined amount since the last calibration.

Potential cause

Oxygen cells degrade over time due to aging and corrosion. An increasing cell resistance is a good indicator of reduced cell performance. As the cell impedance increases, the cell output falls off, and response time increases. Calibrating the transmitter compensates for the increased cell resistance. If using the transmitter with a Rosemount IMPS or SPS calibration sequencer, increased cell impedance can automatically trigger a calibration.

Recommended actions

1. Check transmitter for accuracy.
2. Calibrate transmitter.

NV Memory Failure

The FF/Device Alerts tab and the transducer EEPROM Corrupt resource block may display the following alerts:

1. Manufacturing
2. Block Integrity Error
3. NV Integrity Error
4. ROM Integrity Error

The non-volatile parameter storage on the CPU board has become unreliable.

Potential cause

This alarm generally occurs during start-up. Rarely, the transmitter could be powered down while a parameter is being stored to the non-volatile memory. The parameter is then tagged as bad on the next power on, and the memory contents are written with default parameters. Calibration data may be lost; recalibrate the transmitter. If the transmitter does not recover automatically, the memory may be faulty. Refer to [Diagnostic alarms](#) for details.

Recommended action

At start-up, wait two minutes with power applied and then cycle power again or reset the transmitter.

NV Writes Deferred

The **FF/Device Alerts** tab or the resource block may display the following alarm: NV Writes Deferred.

Potential cause

A high number of writes has been detected to non-volatile memory. To prevent premature memory failure, the write operation has been deferred. The data is saved on a six-hour cycle. This condition usually exists because a program has been written that writes to function block parameters not normally expected to be written on a cyclic basis.

High Electronics Temperature

The **Device Alerts** tab or the transducer block may display: High Electronic Temperature. This alert indicates that the electronics temperature has exceeded 176 °F (80 °C). The transmitter will cease to operate reliably above 185 °F (85 °C).

Potential cause

The transmitter may require special mounting considerations if installed in a very hot location.

Recommended action

Evaluate mounting location and environment.

ADC Failure

The **Device Alerts** AMS tab or the transducer block may display one of the following alerts:

1. ADC Timeout Error
2. ADC Reference Error

This alert indicates faulty operation of the device electronics.

Potential cause

The transmitter continually monitors the analog to digital converter (ADC) for correct operation. Refer to [Diagnostic alarms](#) for details.

Recommended actions

1. Cycle power.
2. Replace electronics stack.

Line Input Out of Range

The **Device Alerts** AMS tab or the transducer block may display one of the following alarms:

1. Line Frequency Error
2. Line Voltage Low
3. Line Voltage High

This alert indicates that the line power to the transmitter is outside the proper operating limits.

Potential cause

The transmitter power supply continuously monitors the line input. Measured variations in the line input power are used to compensate the sensor heater control to check for faulty line conditions. Refer to [Diagnostic alarms](#) for details.

Recommended action

Check line input power for proper voltage and frequency.

Inter Board Communication Failure

The **FF/Device Alerts** AMS tab or the transducer block may display the alarm: *Inter Board Communication Failure*. This alert indicates a communication failure between the FOUNDATION™ Fieldbus (FF) board and the transmitter.

Potential cause

There is no communication possible between the Fieldbus output board and the transmitter's computer board.

Recommended actions

1. Verify the transmitter is powered.
2. Check the installation of the Fieldbus output board on its carrier board.
3. If the above are OK, replace the carrier board and/or Fieldbus output board.

Simulate Active

This alert may display on the **FF/Device Alerts** AMS tab. This alert occurs when the PWA simulate mode is active. You can now write the PWA active parameters. You can also write the resource block detailed status parameters and the internal alerts in the transducer block where the PWA active alarms originate.

8.4.2 PWA SIMULATE

Setting **PWA_SIMULATE** to **ON** allows simulating the PWA parameters: **FAILED_ACTIVE**, **MAINT_ACTIVE**, and **ADVISE_ACTIVE**.

Allowing simulating means that these parameters get write permission, and the host's written value is the only one which is used for the parameter's read back value. The data which comes from the transmitter is not used in this case.

8.4.3 Fieldbus/PWA simulate

Use the DD method to enable or disable Fieldbus simulation and PlantWeb alerts (PWA) simulation.

Use the Transmitter Options method to enable/disable the Fieldbus or PWA simulation.

Selecting Fieldbus simulation enables both the Fieldbus function block simulation and PWA simulation. Selecting PWA simulation enables PWA simulation only.

⚠ CAUTION

When used improperly, the Simulate feature can alter, disable, or activate transmitter alarms.

Do not use the PWA Simulate feature for normal operations.

Only authorized personnel should use this feature for testing purposes only.

8.4.4 Configure PlantWeb alert (PWA) simulation from AMS

Procedure

1. Run the **Transmitter Options** method.
2. From the **Transmitter Options** menu, select either **Simulate Switch** or **PWA Simulate**.
3. Select **Enable** to enable the simulation feature or **Disable** to disable the simulation feature.
4. Once the method is complete, select the **Simulate PWA** tab in the resource block, [Figure 8-3](#).

If the simulation is enabled, the **PlantWeb Alarm Simulate** parameter is configurable; otherwise it is read-only.

Figure 8-3: Simulate PWA screen

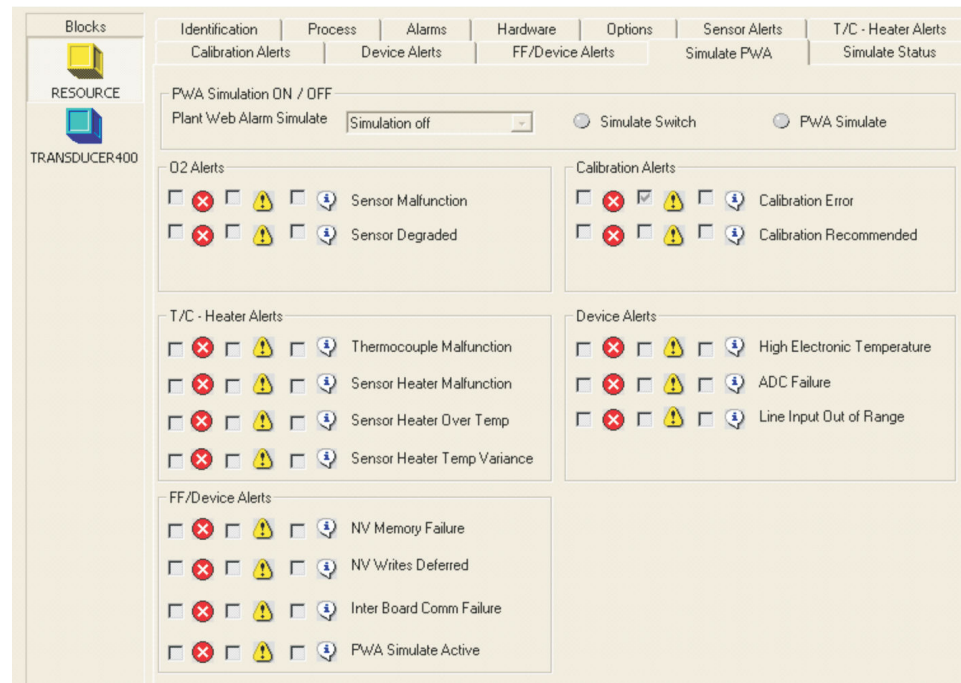

5. Now select Simulation on or Simulation off from the **Simulate PWA** screen. When Fieldbus simulation is on, the **Simulation Switch** LED is illuminated. When PWA simulation is off, the **PWA Simulate** LED is illuminated. If PWA simulation is on, all PWA active parameters and resource and transducer block status parameters are configurable. Otherwise they are read-only.
6. To simulate PlantWeb alerts, use the Simulate PWA screens in the resource block. To simulate block alarms, use **Simulate TB Temperature Sensor - Temperature Status**, **Simulate TB Temperature Status**, or **Simulate TB Calibration Device - FF Status** in the transducer block.
7. Select **Device Diagnostics** to view the active PWA alarms.

8. When **Device Diagnostics** is selected, press **Status** to see the resource or transducer block detailed status displays.

8.5 Configure PlantWeb alert (PWA) simulation with the Field Communicator

Use the following procedure to configure PWA simulation using the Field Communicator.

Procedure

1. Run the Transmitter Options method in the resource block (**Resource** → **Methods**)
2. In the **Transmitter Options** menu, select either **Simulate Switch** or **PWA Simulate**.
3. Select **Enable** to enable PWA simulation or **Disable** to disable the simulation feature.
4. Once the method is complete, select **Resource** → **Simulate PWA** in the resource block.
If the simulation is enabled, the **PWA Simulate** parameter is configurable. Otherwise it is read-only.
5. Now select **Simulation On** or **Simulation Off** from the **PWA Simulate** parameter.
When PWA simulation is on, all of the PWA active parameters and the resource and transducer block status parameters are configurable. Otherwise they are read-only.
6. To simulate PlantWeb Alerts, select the alerts listed under **Failed Active**, **Maintenance Active**, and **Advisory Active** (**Resource** → **Simulate PWA**).
7. To simulate block alarms, select the alarms listed under **Detailed Status** in the resource block (**Resource** → **Simulate PWA**) or under **Detailed Status** in the transducer block (**Transducer** → **Simulate Status**).
8. Select **Resource** → **PWA SubStatus** to see the active PWA alarms and masks. Select **Fail Active**, **Maintenance Active**, or **Advisory Active** for active PWA alarms.
9. Select **Resource** → **Status** → **Detailed Status** or **Transducer** → **Status** → **Detailed Status** to see the resource or transducer block detailed status.

8.5.1 Support resource block errors

Resource block

- Out of Service: Set whenever the resource block actual mode is out of service.
- Power Up: Set whenever the FF card powers up.
- Block Configuration Error: Configure Error is used to indicate that you had selected an item in **FEATURES_SEL** or **CYCLE_SEL** that was not in **FEATURES** or **CYCLE_TYPE** respectively.
- Simulation active: Set whenever the Fieldbus simulate switch is set to **On** at the Fieldbus card or software simulate option enabled.

Transducer block

- Out of Service: Set whenever the transducer block actual mode is out of service.
- Input Failure: Set whenever there is a communication error between the Fieldbus card and the transmitter.
- Simulation Active: Set whenever the **Fieldbus Simulate** switch is set to **On** at the Fieldbus card or the Software simulate option is enabled.

- Other error: Set whenever **XD_ERROR** is non-zero.

8.6 Transducer block

The transducer block was designed to provide the information necessary to interface the transmitter to the Fieldbus.

8.6.1 Transducer block parameters

Table 8-3 gives a description of all parameters or gives the location of the Fieldbus specifications where the description can be found.

Table 8-3: Transducer Block Parameter Descriptions

Parameter mnemonic	Valid range	Units	Description
ALARM_RELAY_EVENT1	See Table 8-7.	Enumerated	The first of three conditions that cause the alarm output to turn on.
ALARM_RELAY_EVENT2	See Table 8-7.	Enumerated	The second of three conditions that cause the alarm output to turn on.
ALARM_RELAY_EVENT3	See Table 8-7.	Enumerated	The third of three conditions that cause the alarm output to turn on.
ALARM_RELAY_STATE	0: Off 1: On	Enumerated	The state of the alarm output.
ALERT_KEY	N/A	N/A	See FF-891, Field Communicator PC connections.
ANALYZER_SW_BUILD_DATE	N/A	N/A	The date the analyzer software was built.
ANALYZER_SW_BUILD_NUMBER	N/A	N/A	The build number of the analyzer software.
ANALYZER_SW_CHECKSUM	N/A	N/A	The checksum of the analyzer software.
ANALYZER_SW_VERSION	N/A	N/A	The version of the analyzer software.
BLOCK_ALM	N/A	N/A	See FF-891, Field Communicator PC connections.
BLOCK_ERR	N/A	N/A	See FF-891, Field Communicator PC connections.
BLOWBACK_DURATION	1-5	Seconds	The amount of time the blowback solenoid will be on.
BLOWBACK_ENABLED	0: No 1: Yes	Enumerated	Enables or disables the automatic blowback cycle.
BLOWBACK_INTERVAL	0-32767	Minutes	The time between blowback cycles.

Table 8-3: Transducer Block Parameter Descriptions (continued)

Parameter mnemonic	Valid range	Units	Description
BLOWBACK_PURGE_TIME	0-500	Seconds	The amount of time before returning the output to process after performing a blowback.
BLOWBACK_STATE	0, 1, 2	Enumerated	The current state of the blowback cycle. (0 = Idle, 1 = Blow, 2 = Purge)
CAL_GAS_TIME	60 - 1200	Seconds	The amount of time calibration gas should flow before a reading is taken.
CAL_PURGE_TIME	60 - 1200	Seconds	The amount of time before returning the output to process after calibrating.
CAL_REC_ENABLE	0: No 1: Yes		Enable/disable calibration recommended alarm.
CAL_RESULTS	See Table 8-10 .	Bit Enum	Calibration result.
CAL_STATE	See Table 8-4 .	Enumerated	The current state of the calibration cycle.
CAL_STATE_STEP	N/A	N/A	Initiates a calibration or goes to the next calibration step.
CAL_STATE_TIME	N/A	Seconds	The time left in the current calibration step.
COLLECTION_DIRECTORY	N/A	N/A	See <i>Transducer Block Specification, Part 1</i> . FF-902, page 11.
COMB_SENSOR_CAL_LOC	N/A	N/A	See FF-903, Section 3.3.
COMB_SENSOR_CAL_METHOD	N/A	N/A	See FF-903, Sections 3.3 and 4.5.
COMB_SENSOR_CAL_WHO			See FF-903, Section 3.3.
COMB_AUTOCAL_INTERVAL	0-9999	Hours	The time between automatic calibrations of the combustibles sensor.
COMB_CAL_POINT	0-55000	ppm	The value of the combustibles test gas.
COMB_CONSTANT	-99.0 to 99.0	ppm	The combustibles calibration constant.
COMB_DELTA_RESISTANCE	N/A	Ohms	The raw value of the combustibles level input. This is the difference between the active and reference RTDs.
COMB_FAILED_CONSTANT	N/A	ppm	This is the constant value calculated from the last failed combustibles calculation.

Table 8-3: Transducer Block Parameter Descriptions (continued)

Parameter mnemonic	Valid range	Units	Description
COMB_FAILED_SLOPE	N/A	ppm/Ohms	This is the slope value calculated from the last failed combustibles calibration.
COMB_HTR_DUTYCYCLE	N/A	N/A	Combustibles heater duty cycle.
COMB_PERCENT_OF_RANGE	N/A	%	The percent of range of the current combustibles reading.
COMB_PREVIOUS_CONSTANT	N/A	ppm	The combustibles calibration constant from the previous good calibration.
COMB_PREVIOUS_SLOPE	N/A	ppm/Ohms	The combustibles calibration slope from the previous good calibration.
COMB_PRIMARY_VALUE	N/A	N/A	The value and status of the combustibles concentration reading.
COMB_PRIMARY_VALUE_RANGE	N/A	N/A	The high and low range limit values, the engineering units code, and the number of digits to the right of the decimal point for the combustibles reading.
COMB_PRIMARY_VALUE_TYPE	N/A	N/A	See FF-903, Section 3.3
COMB_REFERENCE_OHMS	N/A	Ohms	The raw value of the combustibles reference input.
COMB_SECONDARY_VALUE	N/A	N/A	The combustibles cell temperature. This is determined from the value of the combustibles reference resistance temperature device (RTD).
COMB_SECONDARY_VALUE_RANGE	N/A	N/A	The high and low range limit values, the engineering units code, and the number of digits to the right of the decimal point for the combustibles cell temperature reading.
COMB_SENSOR_CAL_DATE	N/A	N/A	See FF-903, Section 3.3
COMB_SENSOR_EXCITATION	N/A	mA	Combustible reference current.
COMB_SENSOR_TYPE	N/A	N/A	See FF-903, Sections 3.3 and 4.3.
COMB_SETPOINT	N/A	° C	Combustibles heater temperature set point.

Table 8-3: Transducer Block Parameter Descriptions (continued)

Parameter mnemonic	Valid range	Units	Description
COMB_SLOPE	200-450	ppm/Ohms	The combustibles calibration slope.
COMB_SLOPE_WARNING	25.0 - 99.0	% of FS	The combustibles slope warning threshold.
COMB_T90	0 - 300	Seconds	The amount of time that the combustibles process variable will take to reach 90% of the actual process variable.
COMB_TEMP_MAX	N/A	° C	The highest combustibles temperature since power on.
COMB_THERMOCOUPLE_INPUT	N/A	mV	Combustible block thermocouple (T/C) voltage (valid only with Type 3 sensor).
COMB_TIME_TO_NEXT	0 - 9999	Hours	The time until the next automatic calibration of the combustibles sensor.
COMB_TOL_CHECK	0: No 1: Yes	N/A	Combustible calibration gas tolerance check.
COZERO_DURATION	120 - 600	Seconds	The duration of the combustibles sensor zero cycle.
COZERO_ENABLED	0: Off 1: On	Enumerated	Indicates whether combustibles sensor zero is enabled.
COZERO_INTERVAL	60 - 480	Minutes	The time between combustibles sensor zero cycles.
COZERO_OUTTRAK	0, 1, 2, 3	Enumerated	Indicates whether the combustibles analog output should track the input during combustibles sensor zero or lock at the last process reading. (0 = None, 1 = O ₂ , 2 = CO ₂ , 3 = Both)
COZERO_PURGE_TIME	60 - 180	Seconds	The duration of the combustibles sensor zero purge.
COZERO_STATE	0, 1, 2	N/A	The current step of the combustibles sensor zero cycle (0 = Idle, 1 = Flowing, 2 = Purging)
COZERO_UPDATE	0: No 1: Yes	Enumerated	Indicates whether the combustibles calibration constants should be updated after combustibles sensor zero.

Table 8-3: Transducer Block Parameter Descriptions (continued)

Parameter mnemonic	Valid range	Units	Description
DETAILED_STATUS_1	0 - 16777215	Bit Enum	A bit-enumerated value used to communicate the status of the transmitter. (This is similar to the command 48 status bits in HART®).
DETAILED_STATUS_2	0 - 16777215	Bit Enum	A bit-enumerated value used to communicate the status of the transmitter. (This is similar to the command 48 status bits in HART).
ELECTRONICS_TEMP	N/A	° C	The current temperature reading of the electronics temperature sensor.
ELECTRONICS_TEMP_INPUT	N/A	mV	The current voltage reading of the electronics temperature sensor.
INITIATE_BLOWBACK	1 = Do a manual blowback	N/A	This initiates a blowback cycle.
LINE_FREQUENCY	N/A	Hz	The calculated line frequency.
LINE_VOLTAGE	N/A	Volts	The calculated line voltage.
MAX_ELECTRONICS_TEMP	N/A	° C	This is the maximum electronics temperature seen by the analyzer.
MAX_TEMP_RESET	1: Reset max temperatures	N/A	This resets the maximum temperatures.
MODE_BLK	N/A	N/A	See <i>FF-891</i> , Section 5.3.
O2_AUTOCAL_INTERVAL	0-9999	Hours	The time between automatic calibrations of the O ₂ sensor.
O2_CAL_POINT_HI	0-40	%	The value of the O ₂ high test gas. This gas is also used as the low gas for calibrating the combustibles temperature.
O2_CAL_POINT_LO	0-40	%	The value of the low O ₂ test gas.
O2_CELL_IMPEDANCE	N/A	Ohms	The instantaneous impedance value for the O ₂ cell.
O2_CONSTANT	-20.0 to 20.0	mV	The O ₂ calibration constant.
O2_FAILED_SLOPE	N/A	mV/Decade	This is the slope value calculated from the last failed O ₂ calculation.
O2_HTR_DUTYCYCLE	N/A	N/A	O ₂ heater duty cycle.

Table 8-3: Transducer Block Parameter Descriptions (continued)

Parameter mnemonic	Valid range	Units	Description
O2_IMPEDANCE_CAL	N/A	Ohms	The impedance value that was calculated as a result of the current successful O ₂ calibration.
O2_PERCENT_OF_RANGE	N/A	%	The percent of range of the current O ₂ reading.
O2_PREVIOUS_CONSTANT	N/A	mV	The O ₂ calibration constant from the previous good calibration.
O2_PREVIOUS_IMPEDANCE	N/A	Ohms	The impedance value from the previous good calibration.
O2_PREVIOUS_SLOPE	N/A	mV/Decade	The O ₂ calibration slope from the previous good calibration.
O2_PRIMARY_VALUE	N/A	N/A	The value and status of the O ₂ concentration reading.
O2_PRIMARY_VALUE_RANGE	N/A	N/A	The high and low range limit values, the engineering units code, and the number of digits to the right of the decimal point for the O ₂ reading.
O2_PRIMARY_VLUE_TYPE	N/A	N/A	See FF-903, Section 3.3.
O2_SECONDARY_VALUE	N/A	N/A	The temperature of the O ₂ cell.
O2_SENSOR_CAL_DATE	N/A	N/A	See FF-903, Section 3.3.
O2_SENSOR_CAL_LOC	N/A	N/A	See FF-903, Section 3.3.
O2_SENSOR_CAL_METHOD	N/A	N/A	See FF-903, Section 3.3 and Section 4.3.
O2_SENSOR_CAL_WHO	N/A	N/A	See FF-903, Section 3.3.
O2_SENSOR_INPUT	N/A	mV	The raw value of the O ₂ sensor input.
O2_SENSOR_TYPE	N/A	N/A	See FF-903, Section 3.3 and Section 4.3.
O2_SETPOINT	N/A	° C	O ₂ heater temperature set point.
O2_SLOPE	34.5-47.5	mV/Decade	The O ₂ calibration slope.
O2_T90	0-300	Seconds	The amount of time that the O ₂ process variable will take to reach 90% of the actual process variable.
O2_TEMP_MAX	N/A	° C	The highest O ₂ temperature read since power on.
O2_THERMOCOUPLE_INPUT	N?A	mV	The raw value of the O ₂ temperature input.

Table 8-3: Transducer Block Parameter Descriptions (continued)

Parameter mnemonic	Valid range	Units	Description
O2_TIME_TO_NEXT_CAL	0-9999	Hours	The time until the next automatic calibration of the O ₂ sensor.
O2_TOL_CHECK	0: No 1: Yes	N/A	O ₂ calibration gas tolerance check.
OPERATING_MODE	N/A	Enumerated	Device operating mode. See Table 8-8 .
PCD_COUNTER	N/A	N/A	Power cycle drop counter.
PCDC_ENABLE	0: No 1: Yes	N/A	Enable/disable power cycle drop detect.
PCN_COUNTER	N/A	N/A	N/A
SB_HTR_DUTYCYCLE	N/A	N/A	Sample block heater duty cycle.
SB_SETPOINT	N/A	° C	Sample block heater temperature set point.
SB_TEMP	N/A	° C	The temperature of the sample line.
SB_TEMP_MAX	N/A	° C	The highest sample block temperature read since power on.
SB_THERMOCOUPLE_INPUT	N/A	mV	The raw value of the sample line temperature input.
SENSOR_HOUSING_TEMP	N/A	° C	Sensor housing temperature (valid only with Type 3 sensor).
SENSOR_HOUSING_TEMP_INPUT	N/A	mV	Sensor housing CJC voltage (valid only with Type 3 sensor).
SENSOR_HOUSING_TEMP_MAX	N/A	° C	The highest sensor housing temperature read since power on.
SENSOR_HOUSING_TYPE	0, 1, 2, 3	Enumerated	This is the sensor housing type setting through the DIP switch. (0 = Type 1, 1 = Type 2, 2 = Type 3, 3 = Invalid)
SOLENOIDS_PRESENT	0: No 1: Yes	Enumerated	This determines whether a calibration cycle will automatically step through, turning solenoids on and off to switch test gas, or wait for an operator to manually switch gases and acknowledge.
ST_REV	N/A	N/A	See <i>FF-891</i> , Section 5.3.
STATS_ATTEMPTS	N/A	N/A	Total number of messages sent to the transducer a/d board.

Table 8-3: Transducer Block Parameter Descriptions (continued)

Parameter mnemonic	Valid range	Units	Description
STATS_FAILURES	N/A	N/A	Total number of failed a/d board message attempts.
STATS_TIMEOUTS	N/A	N/A	Total number of timed out a/d board message attempts.
STRATEGY	N/A	N/A	See <i>FF-891</i> , Section 5.3.
TAG_DESC	N/A	N/A	See <i>FF-891</i> , Section 5.3.
TRANSDUCER_DIRECTORY	N/A	N/A	See <i>FF-903</i> , Section 3.3.
TRANSDUCER_TYPE	N/A	N/A	See <i>FF-903</i> , Section 3.3.
UPDATE_EVT	N/A	N/A	See <i>FF-891</i> , Section 5.3.
VERIFY_STATE	0 through 5	Enumerated	The current state of the calibration check. (0 = Idle, 1 = Flow high O ₂ , 2 = Flow lo O ₂ , 3 = Flow high COe, 4 = Purge gas, 5 = Done)
VERIFY_STATE_STEP	0, 1, 2, 3, 6	Enumerated	Initiates a calibration verify of O ₂ or combustibles gas. (0 = Start flow high O ₂ , 1 = Start flow lo O ₂ , 2 = Start flow high COe, 3 = Purge gas, 6 = No effect)
VERIFY_STATE_TIME	N/A	Seconds	Time remaining for the current calibration check state.
XD_ERROR	N/A	N/A	See <i>FF-903</i> , Section 3.3.

8.7 Transducer block enumerations

8.7.1 Calibration states

During a running calibration procedure, the states below reflect the current step that the calibration is running in.

Refer to [Table 8-4](#).

Table 8-4: Calibration State: Values

Index	CAL_STATE description	Operator acknowledgement required to continue?
0	Idle	Yes, calibration can also be initiated from internally generated events.
1	Apply O ₂ low gas	Yes, if parameter Solenoids Present is 0.
2	Flow O ₂ low gas	No
3	Read O ₂ low gas	No
4	Apply O ₂ high gas	Yes, if parameter Solenoids Present is 0.

Table 8-4: Calibration State: Values (continued)

Index	CAL_STATE description	Operator acknowledgement required to continue?
5	Flow O ₂ high gas	No
6	Read O ₂ high gas	No
7	Apply combustibles low gas	Yes, if parameter Solenoids Present is 0.
8	Flow combustibles low gas	No
9	Read combustibles low gas	No
10	Apply combustibles high gas	Yes, if parameter Solenoids Present is 0..
11	Flow combustibles high gas	No
12	Read combustibles high gas	No
13	Stop gas	Yes, if parameter Solenoids Present is 0.
14	Purge	No
15	Abort	Yes, if parameter Solenoids Present is 0.

8.7.2 Calibration step command

During calibration, the **CAL_STATE_STEP** command/parameter controls the calibration procedure. The procedure progresses forward on the value of **CALIB_STATE**.

Table 8-5: Calibration Control Enumerations

CAL_STATE_STEP description
No event
Start O ₂ calibration
Start combustibles calibration
Start O ₂ and combustibles calibration
Step calibration
Abort calibration

Starting a calibration procedure of a sensor is only allowed if there is no procedure already running on the same sensor. If you do not want to wait to finish the already running procedure, you first have to cancel it before starting the new procedure.

Table 8-6: Blowback State Enumerations

BLOWBACK_STATE description
Idle
Blow
Purge

Table 8-7: Alarm Event Enumerations

ALARM_RELAY_EVENT description
Off
In calibration
O ₂ cell temp error
O ₂ heater open
O ₂ cell bad
Cal failed
Cal warn
High electronics temp
Unit failure
SL temp error
Comb cell temp error
Power input error
In COe zero
All

Table 8-8: Operating Mode Enumerations

Operating mode description
POWER UP
WARMUP
STABILIZE
NORMAL
CALIBRATING
CALVERIFY
BLOWBACK
COZERO
ALARM
SYS FAULT
CAL RECOMMENDED

Table 8-9: Sensor Housing Enumerations

SENSOR_HOUSING_TYPE description
TYPE 1
TYPE 2
TYPE 3

Table 8-10: Cal Results Bit Enumerations

CAL_RESULTS description
O ₂ slope error
O ₂ constant error
O ₂ tolerance check failed
CO slope error
CO constant error
CO tolerance check failed
CO slope warning

During a running calibration verify procedure, the states below reflect the current step that the calibration verify is running in.

Table 8-11: Calibration Verify State Values

VERIFY_STATE description
Idle
Flow high O ₂ gas
Flow low O ₂ gas
Flow high COe gas
Purge gas
Done

During a calibration, the **VERIFY_STATE_STEP** command/parameters control the calibration verify procedure.

Table 8-12: Calibration Verify Step Values

VERIFY_STATE_STEP description
Start flow high O ₂ gas
Start flow low O ₂ gas
Start flow high COe gas
Purge gas
No effect

Table 8-13: COe Zero State Enumerations

COZERO_STATE description
Idle
Flowing
Purging

Table 8-14: COe out Tracks Enumerations

COZERO_OUTTRAK description
None

Table 8-14: COe out Tracks Enumerations (continued)

COZERO_OUTTRAK description
O ₂
CO ₂
Both

Table 8-15: Detailed Status

Alarm number	Description	Value of XD_ERROR (see FF-903)
0	No alarm active	N/A
1	O ₂ cell open	Mechanical failure
2	O ₂ cell impedance high	Mechanical failure
3	O ₂ thermocouple open	Mechanical failure
4	O ₂ thermocouple shorted	Mechanical failure
5	O ₂ thermocouple reversed	Mechanical failure
6	O ₂ cell temperature low	Mechanical failure
7	O ₂ cell temperature high	Mechanical failure
8	O ₂ cell temperature very high	Mechanical failure
9	O ₂ heater failure	Mechanical failure
10	O ₂ heater ramp rate	Electronics failure
11	Combustibles cell error	Mechanical failure
12	Combustibles thermocouple open	Mechanical failure
13	Combustibles thermocouple shorted	Mechanical failure
14	Combustibles thermocouple reversed	Mechanical failure
15	Combustibles temperature low	Mechanical failure
16	Combustibles temperature high	Mechanical failure
17	Combustibles temperature very high	Mechanical failure
18	Combustibles heater failure	Mechanical failure
19	Combustibles heater ramp rate	Electronics failure
20	Sample block thermocouple open	Mechanical failure
21	Sample block thermocouple shorted	Mechanical failure
22	Sample block thermocouple reversed	Mechanical failure
23	Sample block temperature low	Mechanical failure
24	Sample block temperature high	Mechanical failure
25	Sample block temperature very high	Mechanical failure
26	Sample block heater failure	Mechanical failure
27	Sample block heater ramp rate	Electronics failure
28	O ₂ calibration failed	Calibration error
29	Combustibles calibration failed	Calibration error

Table 8-15: Detailed Status (continued)

Alarm number	Description	Value of XD_ERROR (see FF-903)
30	Combustibles calibration warning	Calibration error
31	O ₂ calibration recommended	Calibration error
32	EEPROM corrupt	Data integrity error
33	High electronics temperature	Electronics failure
34	ADC timeout error	Electronics failure
35	ADC reference error	Electronics failure
36	Heater relay failed	Electronics failure
37	Line frequency error	Electronics failure
38	Line voltage low	Electronics failure
39	Line voltage high	Electronics failure
40	Inter-board communication failure	Electronics failure
N/A	Reserved for FB	N/A

8.7.3 Transducer block channel assignments for analog input (AI) blocks

Table 8-16 lists the Rosemount OCX8800 transducer block in/out channels for the AI block.

Table 8-16: I/O Channel Assignments

Transducer block channel value	Process variable	XD_SCALE_UNITS
1	O ₂ concentration	%
2	Combustibles concentration	ppm
3	O ₂ cell temperature	° C
4	Combustibles cell temperature	° C

Table 8-17 lists the recommended settings for the Rosemount OCX8800 transducer block I/O channels for the AI blocks.

Table 8-17: Recommended Settings for the I/O Channel Assignments for the A/I Blocks

Transducer block I/O channel value	LTYPE	XD-Scale 0%	XD-Scale 100%	Units	OUT_SCALE 0%	OUT_SCALE 100%	Units
1	Direct	0	100	%	0	100	%
2	Direct	0	1000	ppm	0	1000	ppm
3	Direct	0	1000	° C	0	1000	° C
4	Direct	0	1000	° C	0	1000	° C

8.7.4 Transducer block channel status

The status of channels 1 through 4 are affected by the state of the unit alarm. In all cases, the channel reads what it believes are the correct sensor values. Self-clearing alarms are reset when the alarm condition goes away. All others require the device to be restarted.

Table 8-18 indicates channel status under indicated device conditions (Occurrence). Unless, otherwise indicated in the table, the status values are:

- Occurrence: Normal
- Quality value: GOOD
- Quality substatus value: NON_SPECIFIC
- Limit value: NOT_LIMITED

Table 8-18: I/O Channel Status

Channel	Occurrence	Quality value	Quality substatus value	Limit value
1, 2	Powerup, Warmup, Stabilize	BAD	NON_SPECIFIC	NOT_LIMITED
1, 2	Normal	GOOD	NON_SPECIFIC	NOT_LIMITED
1, 2	Calibrating, Cal verify, Blowback, COe zero	UNCERTAIN	SENSOR_CONVERSION_INACCU RATE	NOT_LIMITED
1, 2	Alarm (Temperature low & high, Cell bad/error)	UNCERTAIN	SENSOR_CONVERSION_INACCU RATE	NOT_LIMITED
1, 2	System fault	BAD	DEVICE_FAILURE	NOT_LIMITED
3, 4	Powerup, Warmup, Stabilize	GOOD	NON_SPECIFIC	NOT_LIMITED
3, 4	Normal	GOOD	NON_SPECIFIC	NOT_LIMITED
3, 4	Calibrating, Cal verify, Blowback	GOOD	NON_SPECIFIC	NOT_LIMITED
3, 4	Alarm, System fault (Temperature related alarms: thermocouple (T/C) open, T/C shorted, T/C reversed, ADC error)	BAD	DEVICE_FAILURE	CONSTANT
3, 4	Temp low & high	GOOD	ACTIVE_BLOCK_ALARM	NOT_LIMITED

8.7.5 Transducer block simulate

Setting **PWA_SIMULATE** to **ON** also allows simulating transducer block status and checking the correct mapping onto the PlantWeb alert's **FAILED_ACTIVE**, **MAINT_ACTIVE**, and **ADVISE_ACTIVE** parameters.

8.7.6 Support transducer block errors

- Out of service: Set whenever the transducer block actual mode is OOS.

- Input failure: Set whenever there is a communication error between the Fieldbus A2D card and the transmitter.
- Simulation active: Set whenever the Fieldbus simulate switch is set to **ON** at the Fieldbus A2D card or the software simulate option is enabled.
- Other error: Set whenever **XD_ERROR** is non-zero.

8.8 Analog input (AI) function block

8.8.1 Introduction

The transmitter has four transducer block input/output channels (Table 8-22) for the analog input (AI) function blocks. The status of channel values are defined in Table 8-24.

The analog input AI function block (Figure 8-4) processes field device measurements and makes them available to other function blocks. The output value from the AI block is in engineering units and contains a status indicating the quality of the measurement. The measuring device may have several measurements or derived values available in different channels. Use the channel number to define the variable that the AI block processes.

Figure 8-4: AI Function Block

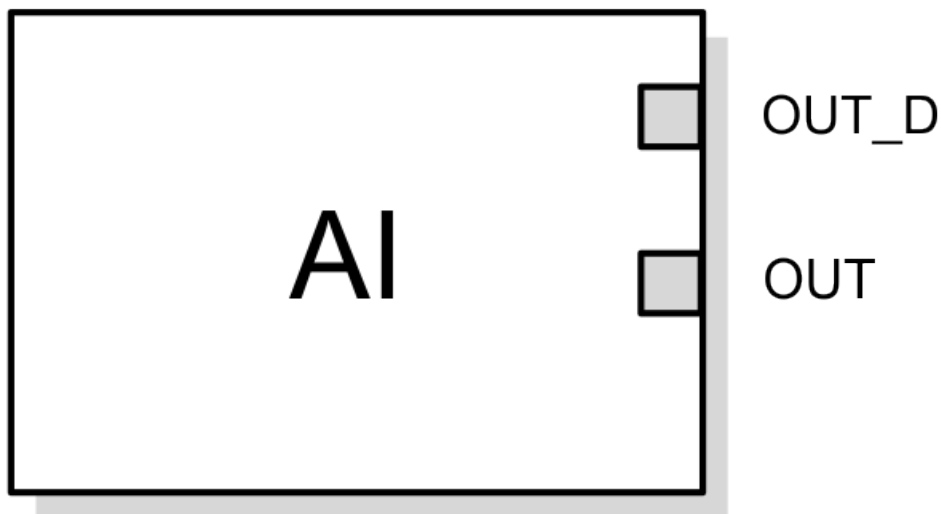

OUT = The block output value and status

OUT_D = Discrete output that signals a selected alarm condition

The analog input (AI) function block processes field device measurements and makes them available to other function blocks. The output value from the AI block is in engineering units and contains a status indicating the quality of the measurement. The measuring device may have several measurements or derived values available in different channels. Use the channel number to define the variable AI block processes.

The AI block supports alarming, signal scaling, signal filtering, signal status calculation, mode control, and simulation. In Automatic mode, the block's output parameter (OUT) reflects the process variable (PV) value and status. In Manual mode, you can set OUT manually. The Manual mode is reflected on the output status. A discrete output (OUT_D) is

provided to indicate whether a selected alarm condition is active. Alarm detection is based on the OUT value and user specified alarm limits. [Table 8-19](#) lists the AI block parameters and their units of measure, descriptions, and index numbers.

Table 8-19: Definitions of AI Function Block System Parameters

Parameter	Index number	Units	Description
ACK_OPTION	23	None	Used to set auto acknowledgement of alarms.
ALARM_HYS	24	Percent	The amount the alarm value must return within the alarm limit before the associated active alarm condition clears.
ALARM_SEL	38	None	Used to select the process condition alarms that will cause the OUT_D parameter to be set.
ALARM_SUM	22	None	The summary alarm is used for all process alarms in the block. The cause of the alert is entered in the Subcode field. The first alert to become active will set the Active status in the Status parameter. As soon as the Unreported status is cleared by the alert reporting task, another block alert may be reported without clearing Active status if the subcode has changed.
ALERT_KEY	04	None	The identification number of the plant unit. This information may be used in the host for sorting alarms, etc.
BLOCK_ALM	21	None	The block alarm is used for all configuration, hardware, connection failure, or system problems in the block. The cause of the alert is entered in the Subcode field. The first alert to become active will set the Active status in the Status parameter. As soon as the Unreported status is cleared by the alert reporting task, another block alert may be reported without clearing Active status if the subcode has changed.
BLOCK_ERR	06	None	This parameter reflects the error status associated with the hardware or software components associated with a block. It is a bit string, so that multiple errors may be shown.

Table 8-19: Definitions of AI Function Block System Parameters (continued)

Parameter	Index number	Units	Description
CHANNEL	15	None	The CHANNEL value is used to select the measurement value. Refer to the appropriate device manual for information about the specific channels available in each device. You must configure the CHANNEL parameter before you can configure the XD_SCALE parameter.
FIELD_VAL	19	Percent	The value and status from the transducer block or from the simulated input when simulation is enabled.
GRANT_DENY	12	None	Options for controlling access of host computers and local control panels to operating, tuning, and alarm parameters of the block. Not used by transmitter.
HI_ALM	34	None	The HI alarm data, which includes a value of the alarm, a timestamp of occurrence, and the state of the alarm.
HI_HI_ALM	33	None	The HI HI alarm data, which includes a value of the alarm, a timestamp of occurrence, and the state of the alarm.
HI_HI_LIM	26	EU of PV_SCALE	The setting for the alarm limit used to detect the HI HI alarm condition.
HI_HI_PRI	25	None	The priority of the HI HI alarm.
HI_LIM	28	EU of PV_SCALE	The setting for the alarm limit used to detect the HI alarm condition.
HI_PRI	27	None	The priority of the HI alarm.
IO_OPTS	13	None	Allows the selection of input/output options used to alter the PV. Low cutoff enabled is the only selectable option.
L_TYPE	16	None	Linearization type. Determines whether the field value is used directly (Direct), is converted linearly (Indirect), or is converted with the square root (Indirect Square Root).
LO_ALM	35	None	The LO alarm data, which includes a value of the alarm, a timestamp of occurrence, and the state of the alarm.

Table 8-19: Definitions of AI Function Block System Parameters (continued)

Parameter	Index number	Units	Description
LO_LIM	30	EU of PV_SCALE	The setting for the alarm limit used to detect the LO alarm condition.
LO_LO_ALM	36	None	The LO LO alarm data, which includes a value of the alarm, a timestamp of occurrence, and the state of the alarm.
LO_LO_LIM	32	EU of PV_SCALE	The setting for the alarm limit used to detect the LO LO alarm condition.
LO_LO_PRI	31	None	The priority of the LO LO alarm.
LO_PRI	29	None	The priority of the LO alarm.
LOW_CUT	17	%	If percentage value of transducer input fails below this, PV = 0.
MODE_BLK	05	None	The actual target, permitted, and normal modes of the block. Target: The mode to go to. Actual: The mode the block is currently in. Permitted: Allowed modes that target may take on. Normal: Most common mode for target.
OUT	08	EU of OUT_SCALE	The block output value and status.
OUT_D	37	None	Discrete output to indicate a selected alarm condition.
OUT_SCALE	11	None	The high and low scale values, engineering units code, and a number of digits to the right of the decimal point associated with OUT.
PV	07	EU of XD_SCALE	The process variable used in block execution.
PV_FTIME	18	Seconds	The time constant of the first-order PV filter. It is the time required for a 63% value change in the IN value.
SIMULATE	09	None	A group of data that contains the current transducer value and status, the simulated transducer value and status, and the enable/disable bit.

Table 8-19: Definitions of AI Function Block System Parameters (continued)

Parameter	Index number	Units	Description
STRATEGY	03	None	You can use the STRATEGY field to identify grouping of blocks. This data is not checked or processed by the block.
ST_REV	01	None	The revision level of the static data associated with the function block. The revision value will be incremented each time a static parameter value in the block is changed.
TAG_DESC	02	None	The user description of the intended application of the block.
UPDATE_EVT	20	None	This alert is generated by any change in the static data.
VAR_INDEX	39	% of OUT Range	The average absolute error between the PV and its previous mean value over that evaluation time defined by VAR_SCAN.
VAR_SCAN	40	Seconds	The time over which the VAR_INDEX is evaluated.
XD_SCALE	10	None	The high and low scale values, engineering units code, and number of digits to the right of the decimal point associated with the channel input value. The XD_SCALE units code must match the units code of the measurement channel in the transducer block. If the units do not match, the block will not transition to MAN or AUTO.

8.8.2 Simulation

To support testing, you can either change the mode of the block to Manual and adjust the output value, or you can enable simulation through the configuration tool and manually enter a value for the measurement value and its status.

With simulation enabled, the actual measurement value has no impact on the OUT value or the status.

Figure 8-5: Analog Input Function Block Schematic

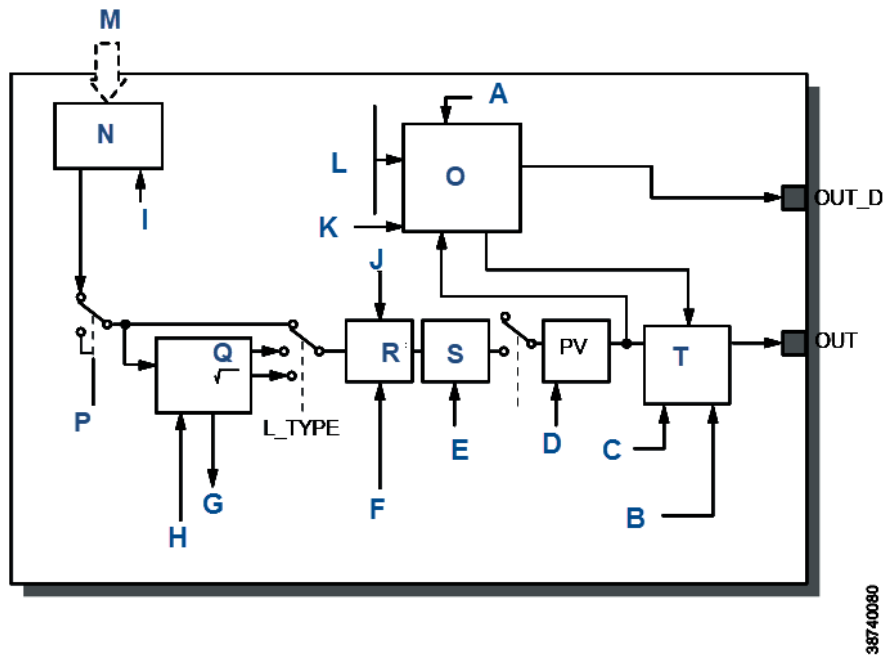

- A. Alarm_type
- B. Status_opts
- C. Mode
- D. Mode
- E. PV_Ftime
- F. IO_opts
- G. Field_val
- H. Out_scale
XD_scale
- I. Channel
- J. Low_cut
- K. Alarm_hys
- L. Hi_Hi_Lim
Hi_Lim
Lo_Lo_Lim
Lo_Lim
- M. Access analog measurement
- N. Alarm detection
- O. Simulate
- P. Convert
- Q. Cutoff
- R. Filter
- S. Status calculation

Note

OUT = Block output value and status.

OUT_D = Discrete output that signals a selected alarm condition.

Figure 8-6: Analog Input Function Block Timing Diagram

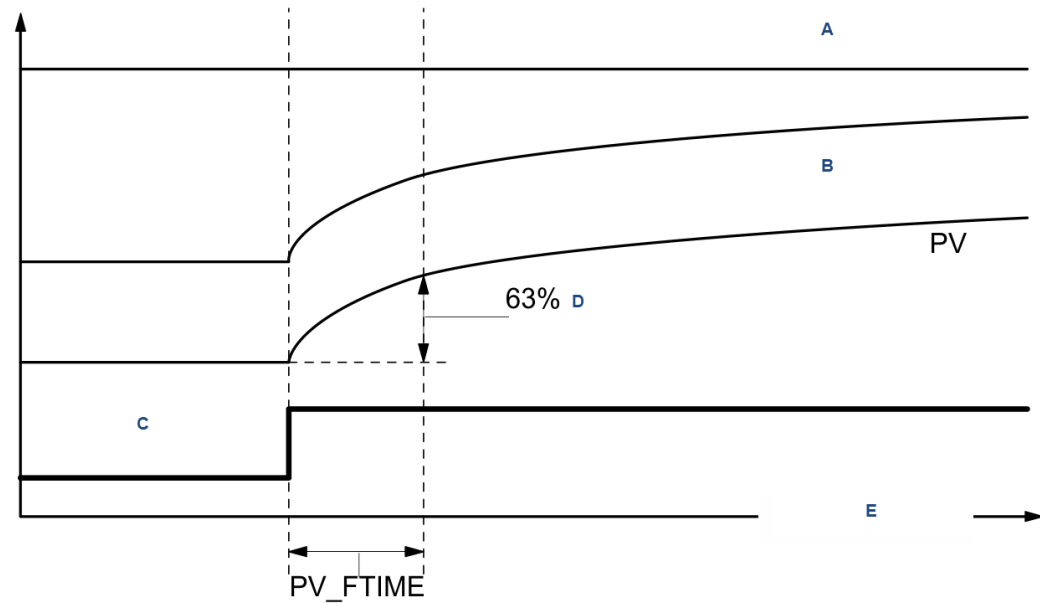

- A. OUT (mode in manual)
- B. OUT (mode in automatic)
- C. FIELD_VALUE
- D. of change
- E. Time (seconds)

8.8.3 Filtering

The filtering feature changes transmitter's response time to smooth variations in input readings caused by rapid changes in input.

You can adjust the filter time constant (in seconds) using the PV_FTIME parameter. Set the filter time constant to zero to disable the filter feature.

8.8.4 Signal conversion

You can set the signal conversion type with the Linearization Type (L_TYPE) parameter. You can view the converted signal (in percent of XD_SCALE) through the FIELD_VAL parameter.

$$\text{FIELD_VAL} = \frac{100 \times (\text{Channel Value} - \text{EU}^* @ 0\%)}{(\text{EU}^* @ 100\% - \text{EU}^* @ 0\%)}$$

* XD_SCALE values

You can choose from direct, indirect, or indirect square root signal conversion with the L_TYPE parameter.

8.8.5 Direct signal conversion

Direct signal conversion allows the signal to pass through the accessed channel input value (or the simulated value when simulation is enabled).

PV = Channel Value

8.8.6 Indirect signal conversion

Indirect signal conversion converts the signal linearly to the accessed channel input value (or the simulated value when simulation is enabled) from its specified range (XD_SCALE) to the range and units of the PV and OUT parameters (OUT_SCALE).

$$PV = \left(\frac{FIELD_VAL}{100} \right) \times (EU^{**}@100\% - EU^{**}@0\%) + EU^{**}@0\%$$

** OUT_SCALE values

8.8.7 Indirect square root

Indirect square root signal conversion takes the square root of the value computed with the indirect signal conversion and scales it to the range and units of the PV and OUT parameters.

$$PV = \sqrt{\left(\frac{FIELD_VAL}{100} \right)} \times (EU^{**}@100\% - EU^{**}@0\%) + EU^{**}@0\%$$

** OUT_SCALE values

When the converted input value is below the limit specified by the LOW_CUT parameter, and the Low Cutoff in/out option (IO_OPTS) is enabled (True), a value of zero is used for the converted value (PV). This option is useful to eliminate false readings when the differential pressure measurement is close to zero, and it may also be useful with zero-based measurement devices such as flow meters.

Note

Low Cutoff is the only I/O option supported by the AI block. You can set the I/O option in Manual or Out of Service mode only.

8.8.8 Block errors

Table 8-20 lists conditions reported in the BLOCK_ERR parameter.

Table 8-20: BLOCK_ERR conditions

Condition number	Condition name and description
0	Other
1	Block configuration error: the selected channel carries a measurement that is incompatible with the engineering units selected in XD_SCALE, the L_TYPE parameter is not configured, or CHANNEL = zero.
2	Link configuration error.
3	Simulate active: Simulation is enabled, and the block is using a simulated value in its execution.

Table 8-20: BLOCK_ERR conditions (continued)

Condition number	Condition name and description
4	Local override.
5	Device fault state set.
6	Device needs maintenance soon.
7	Input failure/process variable has bad status: The hardware is bad, or a bad status is being simulated.
8	Output failure: The output is bad based primarily upon a bad input.
9	Memory failure.
10	Lost static data.
11	Lost NV data.
12	Readback check failed.
13	Device needs maintenance soon.
14	Power up.
15	Out of service: The actual mode is out of service.

8.8.9 Modes

The AI function block supports three modes of operation as defined by the **MODE_BLK** parameter.

- Manual (Man): The block output (OUT) may be set manually.
- Automatic (Auto): OUT reflects the analog input measurement or the simulated value when simulation is enabled.
- Out of service (O/S): The block is not processed. **FIELD_VAL** and **PV** are not updated, and the OUT status is set to Bad: Out of Service. The **BLOCK_ERR** parameter shows Out of Service. In this mode, you can make changes to all configurable parameters. The target mode of a block may be restricted to one or more of the supported modes.

8.8.10 Alarm detection

A block alarm is generated whenever the BLOCK_ERR has an error bit set.

The types of block errors for the AI block are defined in [Block errors](#).

Process alarm detection is based on the **OUT** value. You can configure the alarm limits of the following standard alarms:

- High (HI_LIM)
- High high (HI_HI_LIM)
- Low (LO_LIM)
- Low low (LO_LO_LIM)

In order to avoid alarm chattering when the variable is oscillating around the alarm limit, an alarm hysteresis in percent of the PV span can be set using the **ALARM_HYS** parameter. The priority of each alarm is set in the following parameters:

- HI_PRI

- HI_HI_PRI
- LO_PRI
- LO_LO_PRI

Alarms are grouped into five levels of priority:

Priority number	Priority description
0	The priority of an alarm condition changes to 0 after the condition that caused the alarm is corrected.
1	An alarm condition with a priority of 1 is recognized by the system, but is not reported to the operator.
2	An alarm condition with a priority of 2 is reported to the operator, but does not require operator attention (such as diagnostics and system alerts).
3-7	Alarm conditions of priority 3 through 7 are advisory alarms of increasing priority.
8-15	Alarm conditions of priority 8 to 15 are critical alarms of increasing priority.

8.8.11 Status handling

Normally, the status of the PV reflects the status of the measurement value, the operating condition of the I/O card, and any active alarm condition. In **Auto** mode, **OUT** reflects the value and status quality of the PV. In **Man** mode, the **OUT** status constant limit is set to indicate that the value is constant, and the **OUT** status is **Good**.

The Uncertain - EU range violation status is always set, and the PV status is set high or low limited if the sensor limits for conversion are exceeded.

In the **STATUS_OPTS** parameter, you can select from the following options to control the status handling:

- **BAD if Limited**: Sets the **OUT** status quality to **Bad** when the value is higher or lower than the sensor limits.
- **Uncertain if Limited**: Sets the **OUT** status quality to **Uncertain** when the value is higher or lower than the sensor limits.
- **Uncertain if in Manual mode**: The status of the output is set to **Uncertain** when the mode is set to **Manual**.

Note

The transmitter must be in **Manual** or **Out of Service** mode to set the status option.

Note

The AI block only supports the **BAD if Limited** option. Unsupported options are not grayed out; they appear on the screen in the same manner as supported options.

8.8.12 Advanced features

The AI function block provided with the Rosemount Fieldbus devices provides added capability through the addition of the following parameters.

- **ALARM_TYPE**: Allows one or more of the process alarm conditions detected by the AI function block to be used in setting its **OUT_D** parameter.
- **OUT_D**: Discrete output of the AI function block based on the detection of process alarm condition(s). This parameter may be linked to other function blocks that require a discrete input based on the detected alarm conditions.

- VAR_SCAN: Time period in seconds over which the variability index (**VAR_INDEX**) is computed.
- VAR_INDEX: Process variability index measured as the integral of average absolute error between PV and its mean value over the previous evaluation period. this index is calculated as a percent of OUT span and is updated at the end of the time period defined by **VAR_SCAN**.

8.8.13 Application information

The configuration of the AI function block and its associated output channels depends on the specific application. A typical configuration for the AI block involves the following parameters:

Channel

If the device supports more than one measurement, verify that the selected channel contains the appropriate measurement or derived value.

L_TYPE

Select **Direct** when the measurement is already in the engineering units that you want for the block output.

Select **Indirect** when you want to convert the measured variable into another, for example, pressure into level or flow into energy.

Select **Indirect Square Root** when the block I/O parameter value represents a flow measurement made using differential pressure and when square root extraction is not performed by the transducer.

Scaling

XD_SCALE provides the range and units of the measurement, and **OUT_SCALE** provides the range and engineering units of the output.

8.8.14 Application examples

Temperature transmitter - situation

A temperature transmitter with a range of -328 to 842 °F (-200 to 450 °C).

Temperature transmitter - solution

Table 8-21 lists the appropriate configuration settings, and Figure 8-7 illustrates the correct function block configuration.

Table 8-21: Analog Input Function Block Configuration for a Typical Temperature Transmitter

Parameter	Configured values
L_TYPE	Direct
XD_SCALE	Not used
OUT_SCALE	Not used

Figure 8-7: Analog Input Function Block Configuration for a Typical Temperature Transmitter

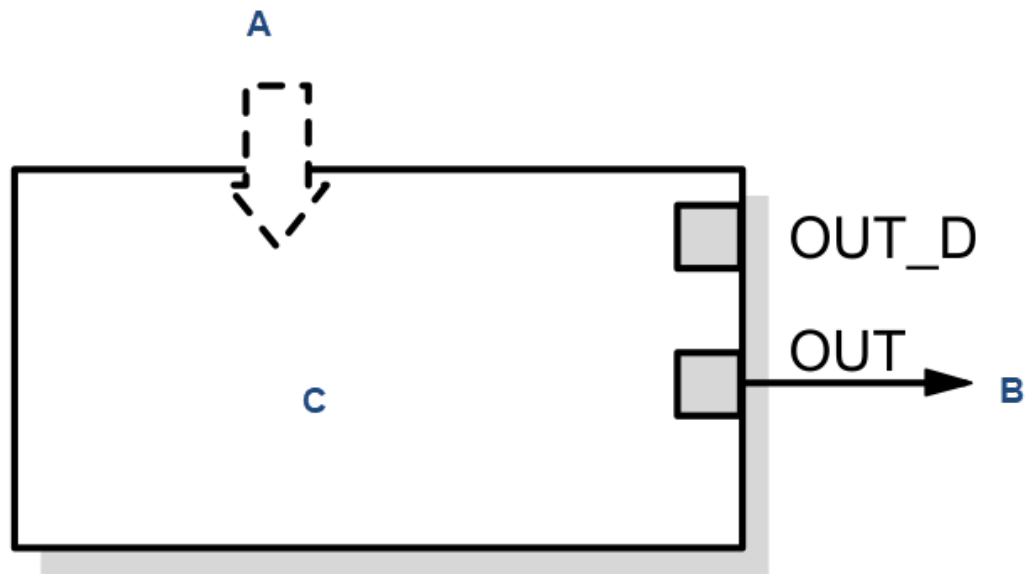

- A. Temperature measurement
- B. AI function block
- C. To another function block

8.8.15 Pressure transmitter used to measure level in an open tank

Situation #1

The level of an open tank is to be measured using a pressure tap at the bottom of the tank. The level measurement will be used to control the level of liquid in the tank. The maximum level at the tank is 16 ft. (4.9 m). The liquid in the tank has a density that makes the level correspond to a pressure of 7.0 psi (0.5 BarG) at the pressure tap ([Figure 8-8](#)).

Figure 8-8: Situation #1 Diagram

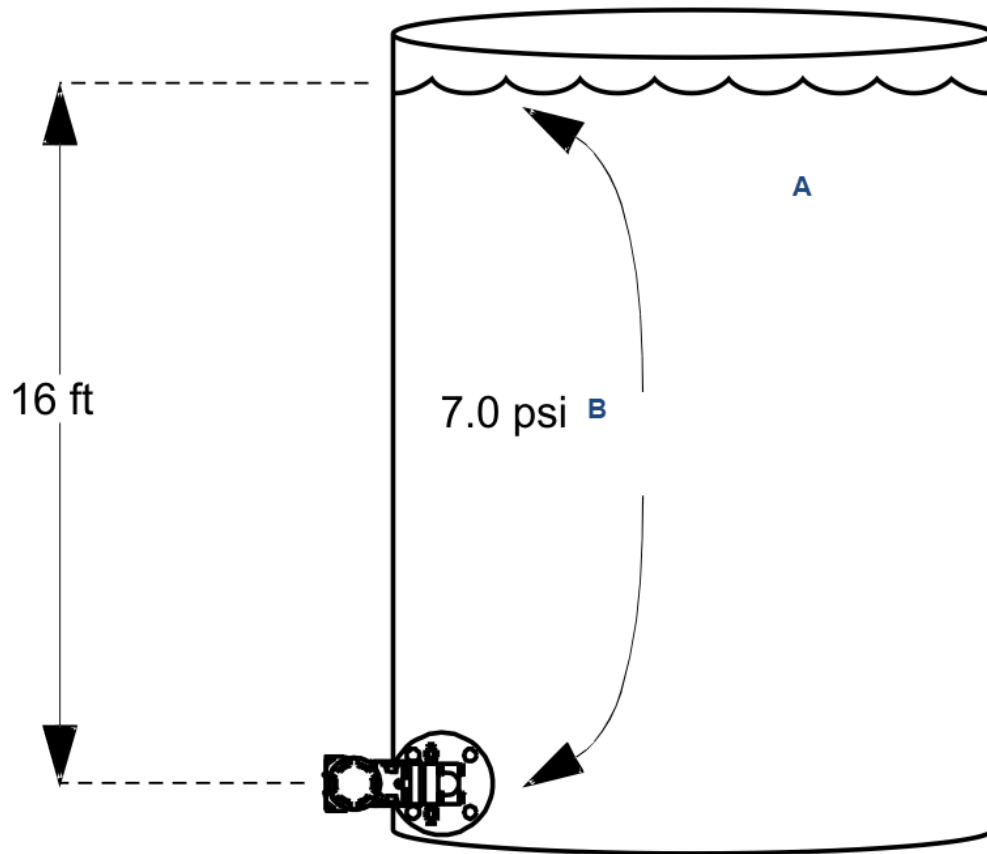

- A. Full tank
- B. Measured at the transmitter

Solution to situation #1

Table 8-22 lists the appropriate configuration settings, and Figure 8-9 illustrates the correct function block configuration.

Table 8-22: Analog Input Function Diagram for a Pressure Transmitter Used in Level Measurement (Situation #1)

Parameter	Configured values
L_TYPE	Indirect
XD_SCALE	0 to 7 psi (0 to 0.5 BarG)
OUT_SCALE	0 to 16 ft (0 to 4.9 m)

Figure 8-9: Function Block Diagram for a Pressure Transmitter Used in Level Measurement

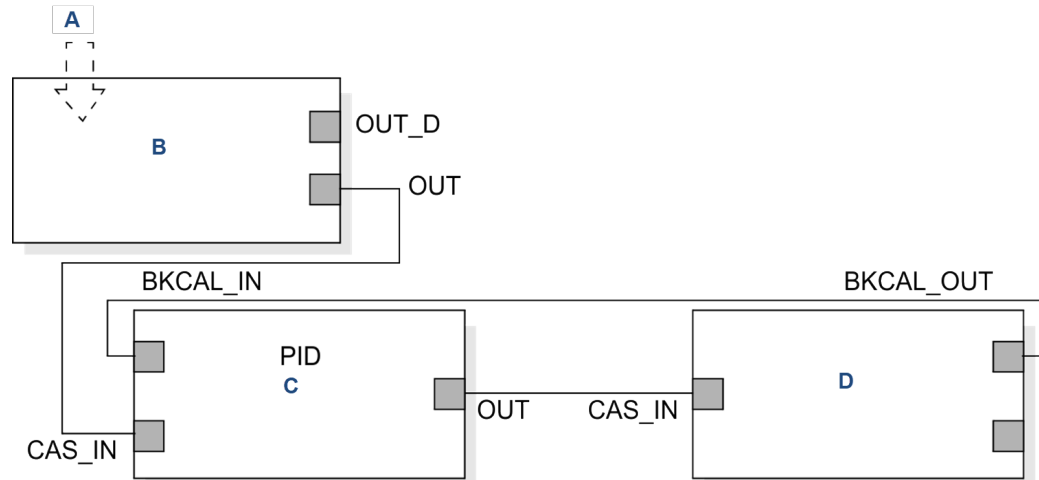

- A. Analog measurement
- B. Analog input function block
- C. Function block
- D. Analog output function block

Situation #2

The transmitter in situation #1 is installed below the tank in a position where the liquid column in the impulse line, when the tank is empty, is equivalent to 2.0 psi (0.1 BarG) (Figure 8-10).

Figure 8-10: Situation #2 Diagram

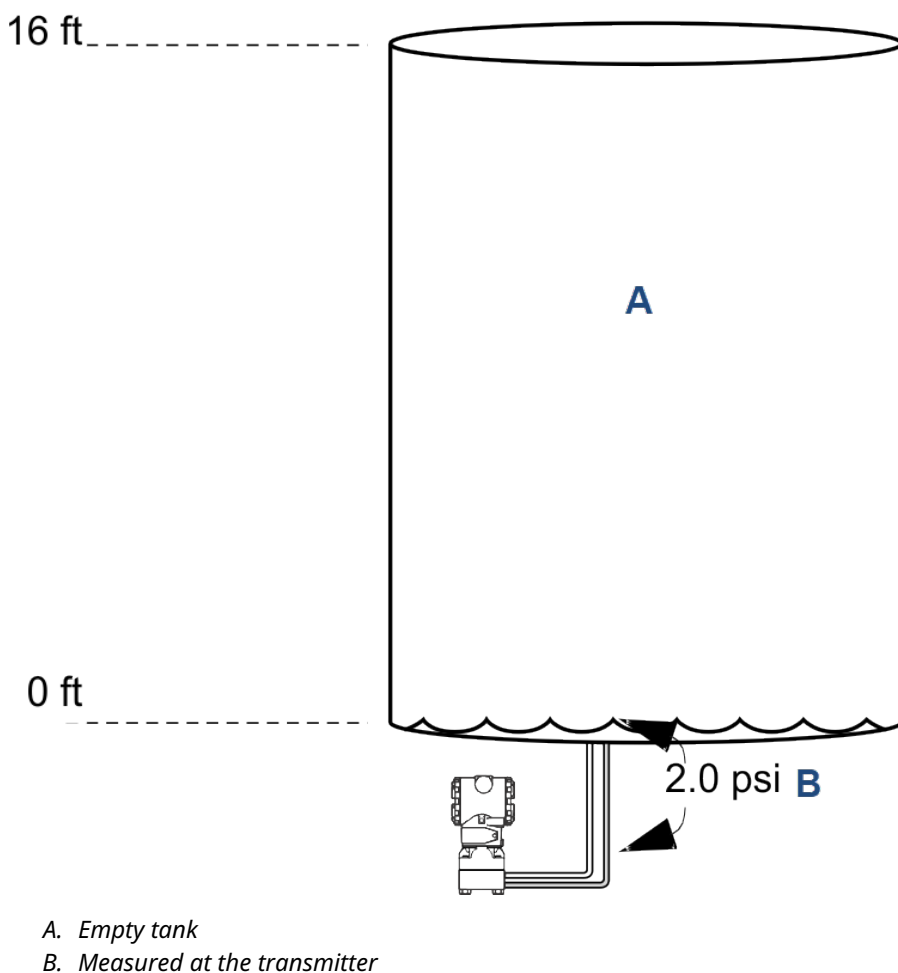

Table 8-23 lists the appropriate configuration settings.

Table 8-23: Analog Input Function Diagram for a Pressure Transmitter Used in Level Measurement (Situation #2)

Parameter	Configured values
L_TYPE	Indirect
XD_SCALE	2 to 9 psi (0.1 to 0.6 BarG)
OUT_SCALE	0 to 16 ft (0 to 4.9 m)

8.8.16 Differential pressure transmitter to measure flow

Situation

The liquid flow in a line is to be measured using the differential pressure across an orifice plate in the line, and the flow measurement will be used in a flow control loop. Based on the orifice specification sheet, the differential pressure transmitter was calibrated for 0

to 20 in. (0 to 508 mm) H₂O for a flow of 0 to 800 gal/min. (0 to 3028.3 L/min.), and the transducer was not configured to take the square root of the differential pressure.

Solution

Table 8-24 lists the appropriate configuration settings, and Figure 8-11 illustrates the correct function block configuration.

Table 8-24: Analog Input Function Block Configuration for a Differential Pressure Measurement

Parameter	Configured values
L_TYPE	Indirect square root
XD_SCALE	0 to 20 in. (0 to 508 mm)
OUT_SCALE	0 to 800 gal/min. (0 to 3028.3 L/min.)

Figure 8-11: Function Block Diagram for a Differential Pressure Transmitter Used in a Flow Measurement

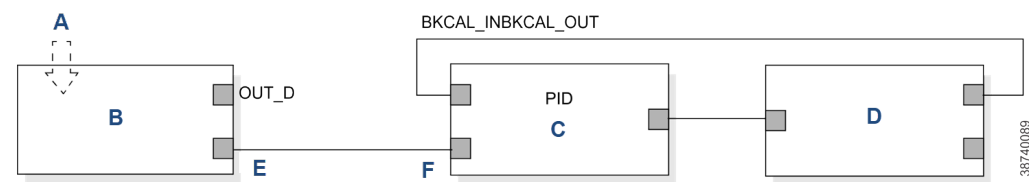

8.8.17 Troubleshoot

Mode will not leave out of service (OOS)

Potential cause

Target mode not set.

Recommended action

Set the target mode to something other than OOS.

Potential cause

Configuration error.

Recommended actions

BLOCK_ERR shows the configuration error bit set. Set the following parameters:

- Set **CHANNEL** to a valid value; do not leave it at the initial value of 0.
- Set **XD_SCALE.UNITS_INDX** to match the units in the transducer block channel value.
- Set **L_TYPE** to **Direct**, **Indirect**, or **Indirect Square Root**; do not leave it at the initial value of 0.

Potential cause

Resource block.

Recommended action

The actual mode of the resource block is OOS. See resource block diagnostics for corrective action.

Potential cause

Schedule. Block is not scheduled and therefore cannot execute to go to **Target** mode.

Recommended action

Schedule the block mode to execute.

Process and/or block alarms will not work

Potential cause

FEATURES_SEL does not have alerts enabled.

Recommended action

Enable the **Alerts** bit.

Potential cause

LIM_NOTIFY is not high enough.

Recommended action

Set **LIM_NOTIFY** to equal **MAX_NOTIFY**.

Potential cause

STATUS_OPTS has **Propagate Fault Forward** bit set.

Recommended action

Clear the **Propagate Fault Forward** bit.

Value of output does not make sense

Potential cause

Linearization type.

Recommended action

Set **L_TYPE** to **Direct**, **Indirect**, or **Indirect Square Root**; do not leave it at the initial value of 0.

Potential cause

Scaling parameters are set incorrectly.

Recommended action

Set **XD_SCALE.EU0** and **EU100** to match that of the transducer block channel value.

Cannot set **HI_LIMIT**, **HI_HI_LIMIT**, **LO_LIMIT**, or **LO_LO LIMIT** values

Potential cause

Limit values are outside the **OUT_SCALE.EU0** and **OUT_SCALE.EU100** values.

Recommended action

Change **OUT_SCALE** or set values within range.

8.9 Proportional/integral/derivative (PID) function block

The PID function block combines all of the necessary logic to perform proportional/integral/derivative (PID) control. The block supports mode control, signal scaling and limiting, feedforward control, override tracking, alarm limit detection, and signal status propagation.

Figure 8-12: Proportional/Integral/Derivative (PID) Function Block

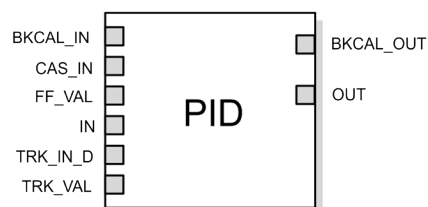

- BKCAL_IN = The analog input value and status from another block's BKCAL_OUT output that is used for backward output tracking for bumpless transfer and to pass limit status.
- CAS_IN = The remote setpoint value from another function block.
- FF_VAL = The feedforward control input value and status.
- IN = The connection for the process variable from another function block.
- TRK_IN_D = Initiates the external tracking function.
- TRK_VAL = The value after scaling applied to OUT in Local Override mode.
- BKCAL_OUT = The value and status required by the BKCAL_IN input of another function block to prevent reset windup and to provide bumpless transfer to closed loop control.
- OUT = The block output and status.

The block supports two forms of the PID equation: Standard and Series. You can choose the appropriate equation using the FORM parameter. The standard ISA PID equation is the default selection.

Figure 8-13: PID Equation: Standard and Series

$$\text{Standard Out} = \text{GAIN} \times e \times \left(1 + \frac{1}{t_r s + 1} + \frac{t_d s}{t_d s + 1} \right) + F$$

$$\text{Series Out} = \text{GAIN} \times e \times \left[\left(1 + \frac{1}{t_r s} \right) + \left(\frac{t_d s + 1}{a \times t_d s + 1} \right) \right] + F$$

Where:

- GAIN** Proportional gain value
- t_r** Integral action time constant (RESET parameter) in seconds
- s** A place operator
- d** Derivative action time rate constant (RATE parameter)
- a** Fixed smoothing factor of 0.1 applied to RATE
- F** Feedforward control contribution from the feedforward input (FF_FVAI parameter)
- e** Error between setpoint and process variable

To further customize the block use for your application, you can configure filtering, feedforward inputs, tracking inputs, setpoint and output limiting, PID equation structures, and block output action. Table 8-25 lists the PID block parameters and their descriptions, units of measure, and index numbers, and Figure 8-14 illustrates the internal components of the PID function block.

Table 8-25: PID Function Block System Parameters

Parameter	Index number	Units	Descriptions
ACK_OPTION	46	None	Used to set auto acknowledgement of alarms.
ALARM_HYS	47	Percent	The amount the alarm value must return to within the alarm limit before the associated active alarm condition clears.
ALARM_SUM	45	None	The summary alarm is used for all process alarms in the block. The cause of the alert is entered in the subcode field. The first alert to become active will set the Active status in the Status parameter. As soon as the Unreported status is cleared by the alert reporting task, another block alert may be reported without clearing the Active status if the subcode has changed.

Table 8-25: PID Function Block System Parameters (continued)

Parameter	Index number	Units	Descriptions
ALERT_KEY	04	None	The identification number of the plant unit. This information may be used in the host for sorting alarms, etc.
ALG_TYPE	74	None	Selects filtering algorithm as backward or bilinear.
BAL_TIME	25	Seconds	The specified time for the internal working value of bias to return to the operator set bias. Also used to specify the time constant at which the integral term will move back to obtain balance when the output is limited and the mode is AUTO, CAS, or RCAS.
BIAS	66	EU of OUT_SCALE	The bias value used to calculate output for a PD type controller.
BKCAL_HYS	30	Percent	The amount the output value must change away from its output limit before the limit status is turned off.
BKCAL_IN	27	EU of OUT_SCALE	The analog input value and status from another block's BKCAL_OUT output that is used for backward output tracking for bumpless transfer and to pass limit status.
BKCAL_OUT	31	EU of PV_SCALE	The value and status required by the BKCAL_IN input of another block to prevent reset windup and to provide bumpless transfer of closed loop control.
BLOCK_ALM	44	None	The block alarm is used for all configuration, hardware, connection failure, or system problems in the block. The cause of the alert is entered in the Subcode field. The first alert to become active will set the Active status in the Status parameter. As soon as the Unreported status is cleared by the alert reporting task, another block alert may be reported without clearing the active status if the subcode has changed.

Table 8-25: PID Function Block System Parameters (continued)

Parameter	Index number	Units	Descriptions
BLOCK_ERR	06	None	This parameter reflects the error status associated with the hardware or software components associated with a block. It is a bit string so that multiple errors may be shown.
BYPASS	17	None	Used to override the calculation of the block. When enabled, the SP is sent directly to the output.
CAS_IN	18	EU of PV_SCALE	The remote setpoint value from another block.
CONTROL_OPTS	13	None	Allows you to specify control strategy options. The supported control options for the PID block are Track enable, Track in Manual, SP-PV Track In Man, SP-PV Track In LO or IMAN, Use PV for BCKAL OUT, and Direct Acting.
DIV_HI_ALARM	64	None	The DV HI alm data, which includes the value of the alarm, a timestamp of occurrence, and the state of the alarm.
DV_HI_LIM	57	EU of PV_SCALE	The setting for the alarm limit used to detect the deviation high alarm condition.
DV_HI_PRI	56	None	The priority of the deviation high alarm.
DV_LO_ALM	65	None	The DV LO alarm data, which includes a value of the alarm, a timestamp of occurrence, and the state of the alarm.
DV_LO_LIM	59	EU of PV_SCALE	The setting for the alarm limit used to detect the deviation low alarm condition.
DV_LO_PRI	56	None	The priority of the deviation low alarm.
ERROR	67	EU of PV_SCALE	The error (SP-PV) used to determine the control action.
FF_ENABLE	70	None	Enables the use of feedforward calculations.
FF_GAIN	42	None	The feedforward gain value. FF_VAL is multiplied by FF_GAIN before it can be added to the calculated control output.

Table 8-25: PID Function Block System Parameters (continued)

Parameter	Index number	Units	Descriptions
FF_SCALE	41	None	The high and low scale values, engineering units code, and number of digits to the right of the decimal point associated with the feedforward value (FF_VAL).
GAIN	23	None	The proportional gain value. This value cannot equal 0.
GRANT_DENY	12	None	Options for controlling access of host computers and local control panels to operating, tuning, and alarm parameters of the block. This is not used by the transmitter.
HI_ALM	61	None	The HI alarm data, which includes a value of the alarm, a timestamp of occurrence, and the state of the alarm.
HI_HI_ALM	60	None	The HI_HI alarm data, which includes a value of the alarm, a timestamp of occurrence, and the state of the alarm.
HI_HI_LIM	49	EU of PV_SCALE	The setting for the alarm limit used to detect the HI HI alarm conditions.
HI_HI_PRI	48	None	The priority of the HI HI alarm.
HI_LIM	51	EU of PV_SCALE	The setting for the alarm limit used to detect the HI alarm condition.
HI_PRI	50	None	The priority of the HI alarm.
IN	15	EU of PV_SCALE	The connection for the PV input from another block.
LO_ALM	62	None	The LO alarm data, which includes a value of the alarm, a timestamp of occurrence, and the state of the alarm.
LO_LIM	53	EU of PV_SCALE	The setting for the alarm limit used to detect the LO alarm conditions.
LO_LO_ALM	63	None	The LO LO alarm data, which includes a value of the alarm, a timestamp of occurrence, and the state of the alarm.
LO_LO_LIM	55	EU of PV_SCALE	The setting for the alarm limit used to detect the LO LO alarm condition.
LO_LO_PRI	54	None	The priority of the LO LO alarm.

Table 8-25: PID Function Block System Parameters (continued)

Parameter	Index number	Units	Descriptions
LO_PRI	52	None	The priority of the LO alarm.
MATH_FORM	73	None	Selects equation form (series or standard).
MODE_BLK	05	None	The actual, target, permitted, and normal modes of the block. Target: The mode to go to Actual: The mode the block is currently in Permitted: Allowed modes that target may take on Normal: Most common mode for target
OUT	09	EU of OUT_SCALE	The block input value and status.
OUT_HI_LIM	28	EU of OUT_SCALE	The maximum output value allowed.
OUT_LO_LIM	29	EU of OUT_SCALE	The minimum output value allowed.
OUT_SCALE	11	None	The high and low scale values, engineering units code, and number of digits to the right of the decimal point associated with OUT.
PV	07	EU of PV_SCALE	The process variable used in block execution.
RATE	26	Seconds	The derivative action time constant.
RCAS_IN	32	EU of PV_SCALE	Target setpoint and status that is provided by a supervisory host. Use when mode is <i>RCAS</i> .
RCAS_OUT	35	EU of PV_SCALE	Block setpoint and status after ramping, filtering, and limiting that is provided to a supervisory host for back calculation to allow action to be taken under limiting conditions or mode change. Used when mode is <i>RCAS</i> .
RESET	24	Seconds per repeat	The integral action time constant.
ROUT_IN	33	EU of OUT_SCALE	Target output and status that is provided by a supervisory host. Used when mode is <i>ROUT</i> .

Table 8-25: PID Function Block System Parameters (continued)

Parameter	Index number	Units	Descriptions
ROUT_OUT	36	EU of OUT_SCALE	Block output that is provided to a supervisory host for a back calculation to allow action to be taken under limiting conditions or mode change. Used when mode is RCAS.
SHED_OPT	34	None	Defines action to be taken on remote control device time-out.
SP	08	EU of PV_SCALE	The target block setpoint value. It is the result of setpoint limiting and setpoint rate of change limiting.
SP_FTIME	69	Seconds	The time constant of the first-order SP filter. It is the time required for a 63 percent change in the IN value.
SP_HI_LIM	21	EU of PV_SCALE	The highest SP value allowed.
SP_LO_LIM	22	EU of PV_SCALE	The lowest SP value allowed.
SP_RATE_DN	19	EU of PV_SCALE per second	Ramp rate for downward SP changes. When the ramp rate is set to zero, the SP is used immediately.
SP_RATE_UP	20	EU of PV_SCALE per second	Ramp rate for upward SP changes. When the ramp rate is set to zero, the SP is used immediately.
SP_WORK	68	EU of PV_SCALE	The working setpoint of the block after limiting and filtering is applied.
STATUS_OPTS	14	None	Allows you to select options for status handling and processing. The supported status option for the PID block is Target to Manual if Bad IN.
STRATEGY	03	None	The <i>Strategy</i> field can be used to identify groupings of blocks. This data is not checked or processed by the block.
ST_REV	01	None	The revision level of the static data associated with the function block. The revision value will be incremented each time a static parameter value in the block is changed.

Table 8-25: PID Function Block System Parameters (continued)

Parameter	Index number	Units	Descriptions
STRUCTURE CONFIG	75	None	Defines PID equation structure to apply controller action.
TAG_DESC	02	None	The user description of the intended application of the block.
TRK_IN_D	38	None	Discrete input that initiates external tracking.
TRK_SCALE	37	None	The high and low scale values, engineering units code, and number of digits to the right of the decimal point associated with external tracking value (TRK_VAL).
TRK_VAL	39	EU of TRK SCALE	The value (after scaling from TRK_SCALE to OUT_SCALE) applied to OUT in LO mode.
UBETA	72	Percent	Used to set disturbance rejection vs. tracking response action for a 2.0 degree of freedom PID.
UGAMMA	71	Percent	Used to set disturbance rejection vs. tracking response action for a 2.0 degree of freedom PID.
UPDATE_EVT	43	None	This alert is generated by any changes to the static data.

Figure 8-14: PID function block schematic

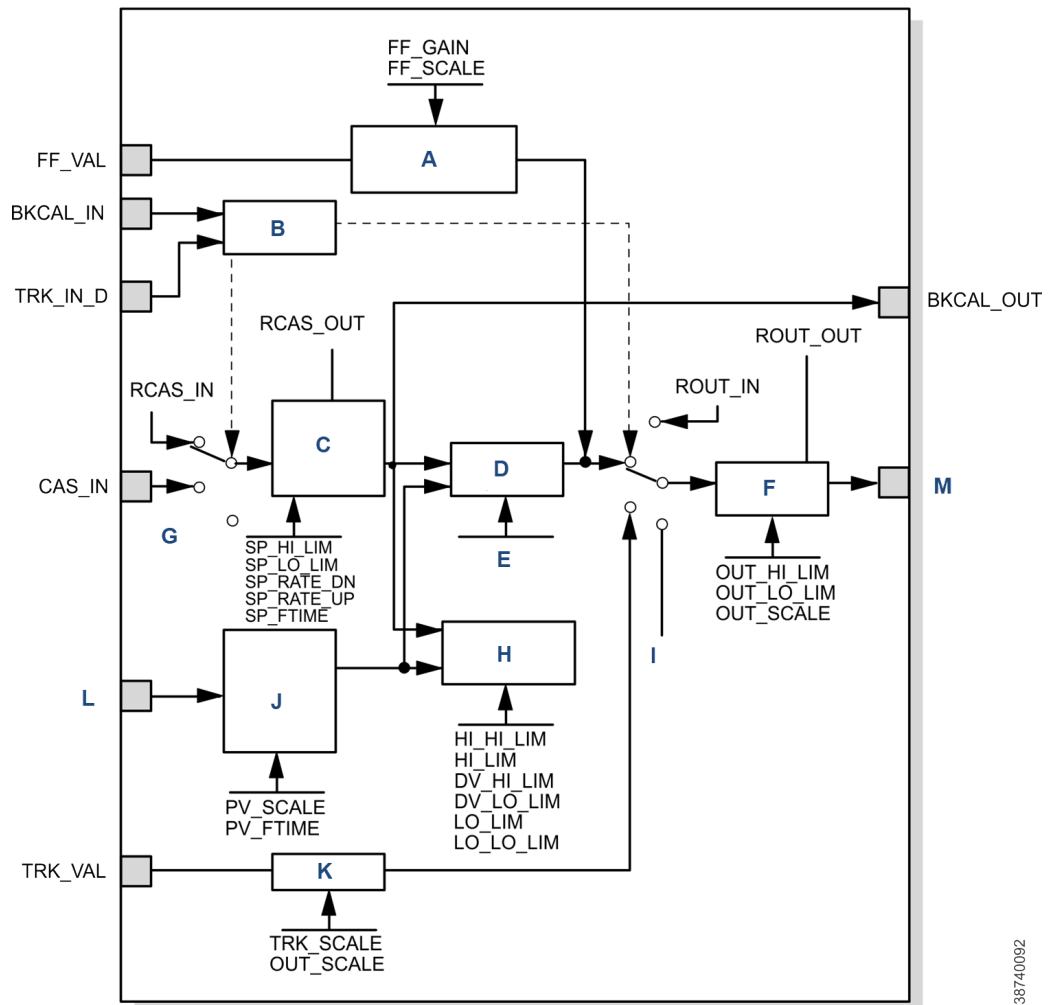

- A. Feedforward calculation
- B. Mode
- C. Setpoint limiting and filtering
- D. PID equation
- E. Output limiting
- F. Gain rate reset
- G. Scaling and filtering
- H. Alarm detection
- I. Operator output
- J. Convert
- K. In
- L. Out

8.9.1 Setpoint selection and limiting

The setpoint of the PID block is determined by the mode. You can configure the SP_HI_LIM and SP_LO_LIM parameters to limit the setpoint. In **Cascade** or **RemoteCascade** mode, the

setpoint is adjusted by another function block or by a host computer, and the output is computed based on the setpoint.

In **Automatic** mode, the operator manually enters the setpoint, and the output is computed based on the setpoint. In **Auto** mode, you can also adjust the setpoint limit and setpoint rate of change using the **SP_RATE_UP** and **SP_RATE_ON** parameters.

In **Manual** mode, the operator manually enters the output, which is independent of the setpoint. In **RemoteOutput** mode, a host computer enters the output, which is independent of the setpoint.

Figure 8-15 illustrates the method for setpoint selection.

Figure 8-15: PID Function Block Setpoint Selection

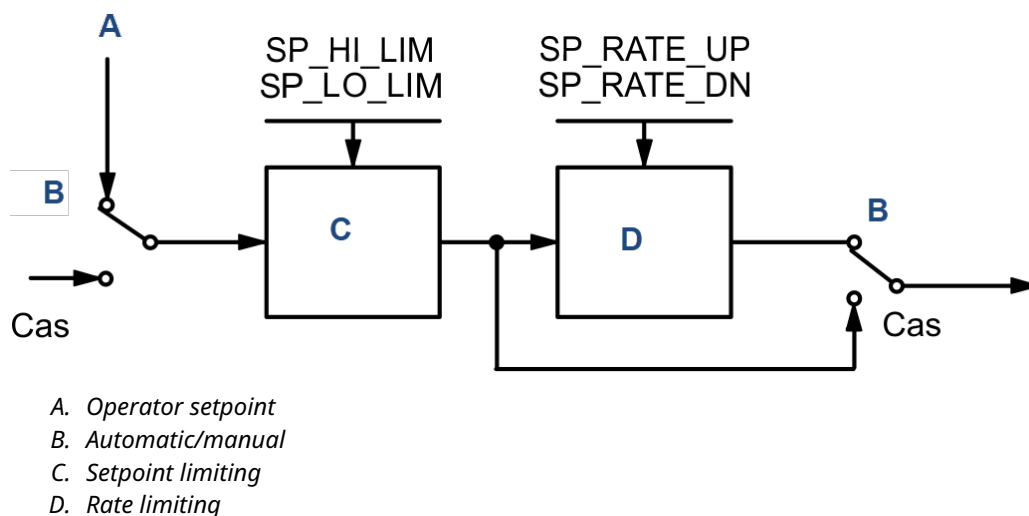

Filtering

The filtering feature changes the response time of the device to smooth variations in output readings caused by rapid changes in input.

You can configure the filtering feature with the **FILTER_TYPE** parameter, and you can adjust the filter time constant (in seconds) using the **PV_FTIME** or **SP_FTIME** parameters. Set the filter time constant to zero to disable the filter feature.

Feedforward calculation

The feedforward value (**FF_VAL**) is scaled (**FF_SCALE**) to a common range for compatibility with the output scale (**OUT_SCALE**).

A gain value (**FF_GAIN**) is applied to achieve the total feedforward contribution.

Tracking

You can enable the use of output tracking through the control options. You can set control options in **Manual** or **Out of Service** mode only.

The **Track Enable** control option must be set to **True** for the track function to operate. When the **Track in Manual** control option is set to **True**, tracking can be activated and maintained only when the block is in **Manual** mode. When **Track in Manual** is **False**, you can override the tracking function when the block is in **Manual** mode. Activating the track function causes the block's actual mode to revert to **Local Override**.

The **TRK_VAL** parameter specifies the value to be converted and tracked into the output when the track function is operating. The **TRK_SCALE** parameter specifies the range of **TRK_VAL**.

When the **TRK_IN_D** parameter is **True**, and the **Track Enable** control option is **True**, the **TRK_VAL** input is converted to the appropriate value and output in units of **OUT_SCALE**.

Output selection and limiting

Output selection is determined by the mode and the setpoint.

In **Automatic**, **Cascade**, or **RemoteCascade** mode, the PID control equation computes the output. In **Manual** or **RemoteOutput** mode, the you may enter the output manually. You can limit the output by configuring the **OUT_HI_LIM** and **OUT_LO_LIM** parameters.

Bumpless transfer and setpoint tracking

You can configure the method for tracking the setpoint by configuring the following control options (CONTROL_OPTS):

- SP-PV Track in Man: Permits the SP to track the PV when the target mode of the block is **Man**.
- SP-PV Track in LO or IMAN: Permits the SP to track the PV when the actual mode of the block is **Local Override (LO)** or **Initialization Manual (IMAN)**.

When one of these options is set, the SP value is set to the PV value while in a specified mode.

You can select the value that a master controller uses for tracking by configuring the **Use PV for BKCAL_OUT** control option. The **BKCAL_OUT** value tracks the PV value. **BKCAL_IN** on a master controller connected to **BKCAL_OUT** on the PID block in an open cascade strategy forces its OUT to match **BKCAL_IN**, thus tracking the PV from the slave PID block into its cascade input connection (CAS_IN). If the Use PV for **BKCAL_OUT** option is not selected, the working setpoint (**SP_WRK**) is used for **BKCAL_OUT**.

You can set control options in **Manual** or **Out of Service** mode only. When the mode is set to **Auto**, the SP will remain at the last value (it will no longer follow the PV).

8.9.2 PID equation structures

Configure the **STRUCTURE** parameter to select the PID equation structure. You can select one of the following choices:

- PI Action on Error, D Action on PV
- PID Action on Error
- I Action on Error, PD Action on PV

Set **RESET** to zero to configure the PID block to perform integral only control regardless of the **STRUCTURE** parameter selection. When **RESET** equals zero, the equation reduces to an integrator equation with a gain value applied to the error.

Figure 8-16: PID Equation Structure

$$\frac{\text{GAIN} \times e(s)}{s}$$

Where:

GAIN	Proportional gain value
e	Error
s	A place operator

8.9.3 Reverse and direct action

To configure the block output action, enable the Direct Acting control option. This option defines the relationship between a change in PV and a corresponding change in output. With Direct Acting enabled (True), an increase in PV results in an increase in the output.

You can set control options in Manual or Out of Service mode only.

Note

Track Enable, Track in Manual, SP-PV Track in Man, SP-PV Track in LO or IMAN, Use PV for BKCAL_OUT, and Direct Acting are the only control options supported by the PID function block. Unsupported options are not grayed out; they appear on the screen in the same manner as supported options.

8.9.4 Reset limiting

The PID function block provides a modified version of feedback reset limiting that prevents windup when output or input limits are encountered and provides the proper behavior in selector applications.

8.9.5 Block errors

Table 8-26 lists conditions reported in the BLOCK_ERR parameter.

Table 8-26: BLOCK_ERR Conditions

Condition number	Condition name and description
0	Other
1	Block Configuration Error: The BY_PASS parameter is not configured and is set to 0 , the SP_HI_LIM is less than the SP_LO_LIM , or the OUT_HI_LIM is less than the OUT_LO_LIM .
2	Link Configuration Error
3	Simulate Active
4	Local Override: The actual mode is LO .
5	Device Fault State Set
6	Device Needs Maintenance Soon
7	Input Failure/Process Variable has Bad Status: The parameter linking to IN is indicating a Bad status.
8	Output Failure

Table 8-26: BLOCK_ERR Conditions (continued)

Condition number	Condition name and description
9	Memory Failure
10	Lost Static Data
11	Lost NV Data
12	Readback Check Failed
13	Device Needs Maintenance Now
14	Power Up
15	Out of Service: The actual mode is out of service.

8.9.6 Modes

The PID function block supports the following modes:

- Manual (Man): The block output (**OUT**) may be set manually.
- Automatic (Auto): The **SP** may be set manually, and the block algorithm calculates **OUT**.
- Cascade (Cas): The **SP** is calculated in another block and is provided to the PID block through the **CAS_IN** connection.
- RemoteCascade (RCas): The **SP** is provided by a host computer that writes to the **RCAS_IN** parameter.
- RemoteOutput (Rout): The **OUT** is provided by a host computer that writes to the **ROUT_IN** parameter.
- Local Override (LO): The track function is active. **OUT** is set by **TRK_VAL**. The **BLOCK_ERR** parameter shows **Out of service**.
- Initialization Manual (IMan): The output path is not complete (for example, the cascade-to-slave path might not be open). In **IMan** mode, **OUT** tracks **BKCAL_IN**.
- Out of Service (O/S): The block is not processed. The **OUT** status is set to **Bad: Out of Service**. The **BLOCK_ERR** parameter shows **Out of service**.

You can configure the **Man**, **Auto**, **Cas**, and **O/S** modes as permitted modes for operator entry.

8.9.7 Alarm detection

A block alarm is generated whenever the **BLOCK_ERR** has an error bit set.

The types of block errors for the AI block are defined in [Block errors](#).

Process alarm detection is based on the **OUT** value. You can configure the alarm limits of the following standard alarms:

- High (HI_LIM)
- High high (HI_HI_LIM)
- Low (LO_LIM)
- Low low (LO_LO_LIM)

In order to avoid alarm chattering when the variable is oscillating around the alarm limit, an alarm hysteresis in percent of the PV span can be set using the **ALARM_HYS** parameter. The priority of each alarm is set in the following parameters:

- HI_PRI
- HI_HI_PRI
- LO_PRI
- LO_LO_PRI

Alarms are grouped into five levels of priority:

Priority number	Priority description
0	The priority of an alarm condition changes to 0 after the condition that caused the alarm is corrected.
1	An alarm condition with a priority of 1 is recognized by the system, but is not reported to the operator.
2	An alarm condition with a priority of 2 is reported to the operator, but does not require operator attention (such as diagnostics and system alerts).
3-7	Alarm conditions of priority 3 through 7 are advisory alarms of increasing priority.
8-15	Alarm conditions of priority 8 to 15 are critical alarms of increasing priority.

8.9.8 Status handling

Normally, the status of the PV reflects the status of the measurement value, the operating condition of the I/O card, and any active alarm condition. In **Auto** mode, **OUT** reflects the value and status quality of the PV. In **Man** mode, the **OUT** status constant limit is set to indicate that the value is constant, and the **OUT** status is **Good**.

The Uncertain - EU range violation status is always set, and the PV status is set high or low limited if the sensor limits for conversion are exceeded.

In the **STATUS_OPTS** parameter, you can select from the following options to control the status handling:

- **BAD if Limited**: Sets the **OUT** status quality to **Bad** when the value is higher or lower than the sensor limits.
- **Uncertain if Limited**: Sets the **OUT** status quality to **Uncertain** when the value is higher or lower than the sensor limits.
- **Uncertain if in Manual mode**: The status of the output is set to **Uncertain** when the mode is set to **Manual**.

Note

The transmitter must be in **Manual** or **Out of Service** mode to set the status option.

Note

The AI block only supports the **BAD if Limited** option. Unsupported options are not grayed out; they appear on the screen in the same manner as supported options.

8.9.9 Application information

The PID function block is a powerful, flexible control algorithm that is designed to work in a variety of control strategies.

The PID block is configured differently for different applications. The following examples describe the use of the PID block for closed-loop control (basic PID loop), feedforward control, cascade control with master and slave, and complex cascade control with override.

Closed loop control

To implement basic closed loop control, compute the error difference between the process variable (PV) and setpoint (SP) values and calculate a control output signal using a PID (proportional integral derivative) function block.

The proportional control function responds immediately and directly to a change in the PV or SP. The proportional term **GAIN** applies a change in the loop output based on the current magnitude of the error multiplied by a gain value.

The integral control function reduces the process error by moving the output in the appropriate direction. The integral term **RESET** applies a correction based on the magnitude and duration of the error. Set the **RESET** parameter to zero for integral only control. To reduce reset action, configure the **RESET** parameter to be a large value.

The derivative term **RATE** applies a correction based on the anticipated change in error. Derivative control is typically used in temperature control where large measurement lags exist.

The **MODE** parameter is a switch that indicates the target and actual mode of operation. Mode selection has a large impact on the operation of the PID block:

- **Manual** mode allows the operator to set the value of the loop output signal directly.
- **Automatic** mode allows the operator to select a setpoint for automatic correction of error using the **GAIN**, **RESET**, and **RATE** tuning values.
- **Cascade** and **Remote Cascade** modes use a setpoint from another block in a cascaded configuration.
- **Remote Out** mode is similar to **Manual** mode except that the block output is supplied by an external program rather than by the operator.
- **Initialization Manual** is a non-target mode used with cascade configurations while transitioning from manual operation to automatic operation.
- **Local Override** is a non-target mode that instructs the blocks to revert to **Local Override** when the tracking or fail-safe control options are activated.
- **Out of Service** mode disables the block for maintenance.

Abrupt changes in the quality of the input signal can result in unexpected loop behavior. To prevent the output from changing abruptly and upsetting the process, select the **SP-PV Track in Man I/O** option. This option automatically sets the loop to **Manual** if a **Bad** input status is detected. While in **Manual** mode, you can manage control manually until a **Good** input status is reestablished.

8.9.10 Application examples

Basic proportional/integral/derivative (PID) block for steam heater control

Situation

A PID block is used with an analog input (AI) block and an analog output (AO) block to control the flow steam used to heat a process fluid in a heat exchanger. Figure 8-17 illustrates the process instrumentation diagram.

Figure 8-17: PID Function Block Steam Heater Control

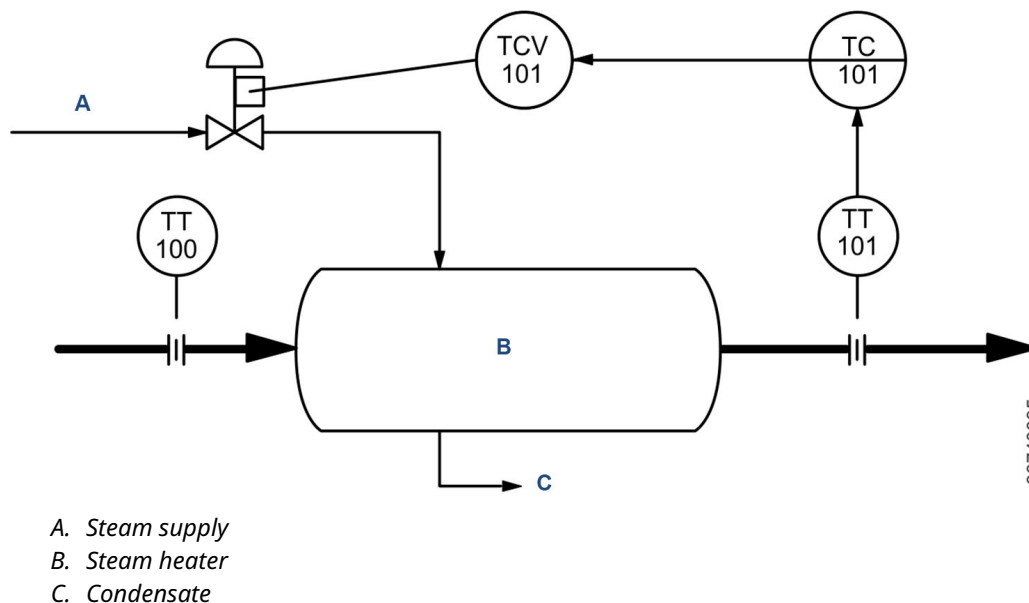

Solution

The PID loop uses TT101 as an input and provides a signal to the analog output TCV101. The **BKCAL_OUT** of the AO block and the **BKCAL_IN** of the PID block communicate the status and quality of information being passed between the blocks. The status indication shows that communications is functioning, and the I/O is working properly. Figure 8-18 illustrates the correct function block configuration.

Figure 8-18: PID Function Block for Steam Heater Control Example

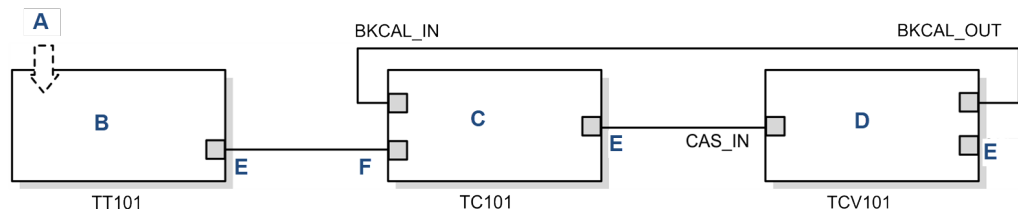

- A. Outlet temperature input
- B. AI function block
- C. PID function block
- D. AO function block
- E. Out
- F. In

Feedforward control

Situation

In the the example in [Basic proportional/integral/derivative \(PID\) block for steam heater control](#), control problems can arise because of a time delay caused by thermal inertia between the two flow streams (TT100 and TT101). Variations in the inlet temperature (TT100) take an excessive amount of time to be sensed in the outlet (TT101). This delay causes the produce to be out of the desired temperature range.

Solution

Feedforward control is added to improve the response time of the basic proportional/integral/derivative (PID) control. The temperature of the inlet process fluid (TT100) is input to an analog input (AI) function block and is connected to the **FF_VAL** connector on the PID block. Feedforward control is then enabled (**FF_ENABLE**), the feedforward value is scaled (**FF_SCALE**), and a gain (**FF_GAIN**) is determined. [Figure 8-19](#) illustrates the process instrumentation diagram, and [Figure 8-20](#) illustrates the correct function block configuration.

Figure 8-19: PID Function Block Feedforward Example

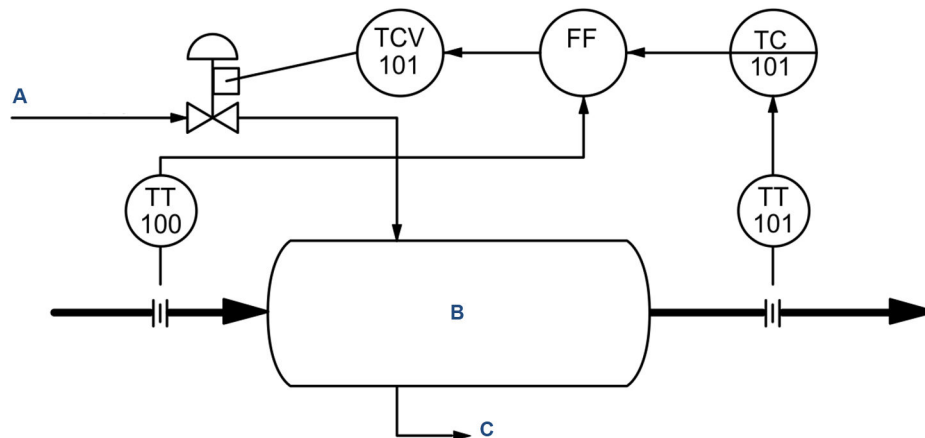

- A. Steam supply
- B. Steam heater
- C. Condensate

Figure 8-20: PID Function Block Diagram for Feedforward Control

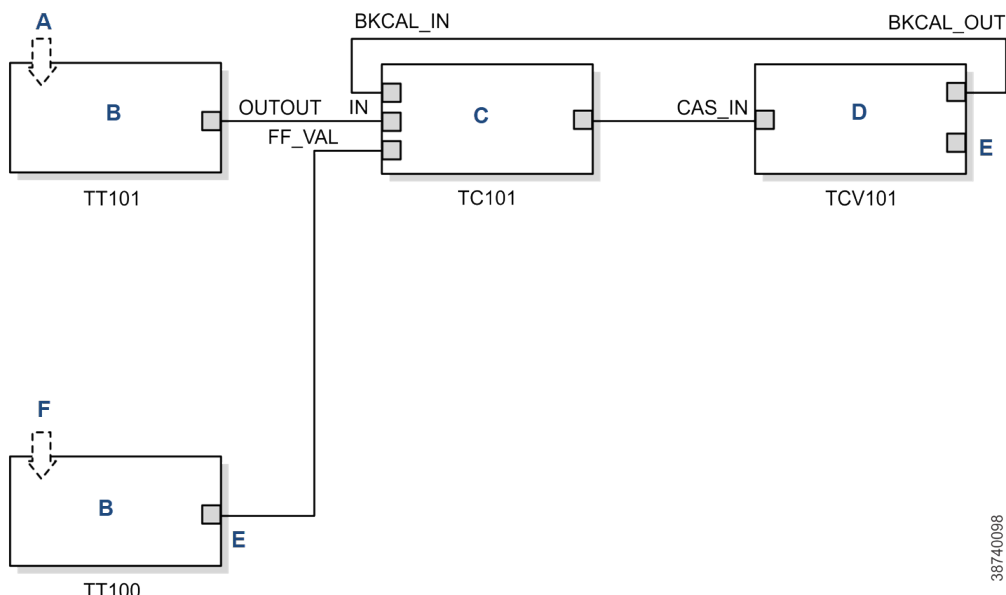

- A. Outlet temperature input
- B. AI function block
- C. PID function block
- D. AO function block
- E. Out
- F. Inlet temperature input

38740098

Cascade control with master and slave loops

Situation

A slave loop is added to a basic proportional/integral derivative (PID) control configuration to measure and control steam flow to the steam heater. Variations in the steam pressure cause the temperature in the heat exchanger to change. The temperature variation will later be sensed by TT101. The temperature controller modifies the valve position to compensate for the steam pressure change. The process is slow and causes variations in the product temperature. Figure 8-21 illustrates the process instrumentation diagram.

Figure 8-21: PID Function Block Cascade Control Example

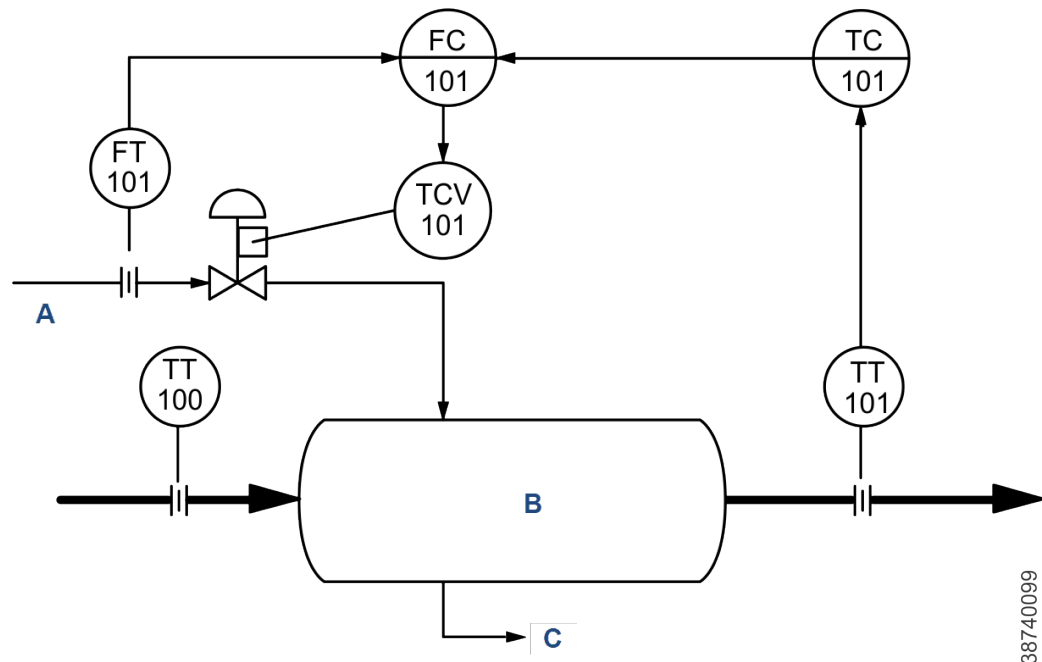

38740099

- A. Steam supply
- B. Steam heater
- C. Condensate

Solution

If the flow is controlled, steam pressure variations will be compensated before they significantly affect the heat exchanger temperature. The output from the master temperature loop is used as the setpoint for the slave steam flow loop. The **BKCAL_IN** and **BKCAL_OUT** connections on the PID blocks are used to prevent controller windup on the master loop when the slave loop is in Manual or Automatic mode or it has reached an output constraint. Figure 8-22 illustrates the correct function block configuration.

Figure 8-22: PID Function Block Diagram for Cascade Control Example

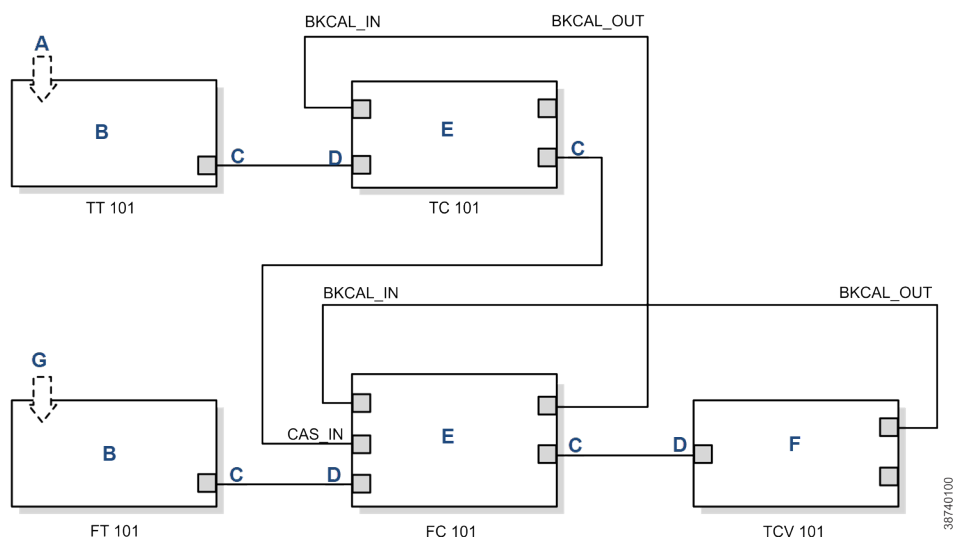

- A. Outlet temperature input
- B. AI function block
- C. Out
- D. In
- E. PID function block
- F. AO module block
- G. Steam flow input

Cascade control with override

You can use the proportional/integral/derivative (PID) function block with other function blocks for complex control strategies.

Figure 8-23 illustrates the function block diagram for cascade control with override.

When configured for cascade control with override, if one of the PID function blocks connected to the selector input is deselected, that PID block filters the integral value to the selected value (the value at its **BKCAL_IN**). The selected PID block behaves normally, and the deselected controller never winds up. At steady state, the deselected PID block offsets its OUT value from the selected value by the proportional term. When the selected block becomes output-limited, it prevents the integral term from winding further into the limited region.

When the cascade between the slave PID block and the control selector block is open, the open cascade status is passed to the control selector block and through to the PID block supplying input to it. The control selector block and the upstream (master) PID blocks have an actual mode of **IMan**.

If the instrument connected to the AI block fails, you can place the AI block in **Manual** mode and set the output to some nominal value for use in the Integrator function block. In this case, IN at the slave PID block is constant and prevents the integral term from increasing or decreasing.

Figure 8-23: Function Block Diagram for Cascade Control with Override

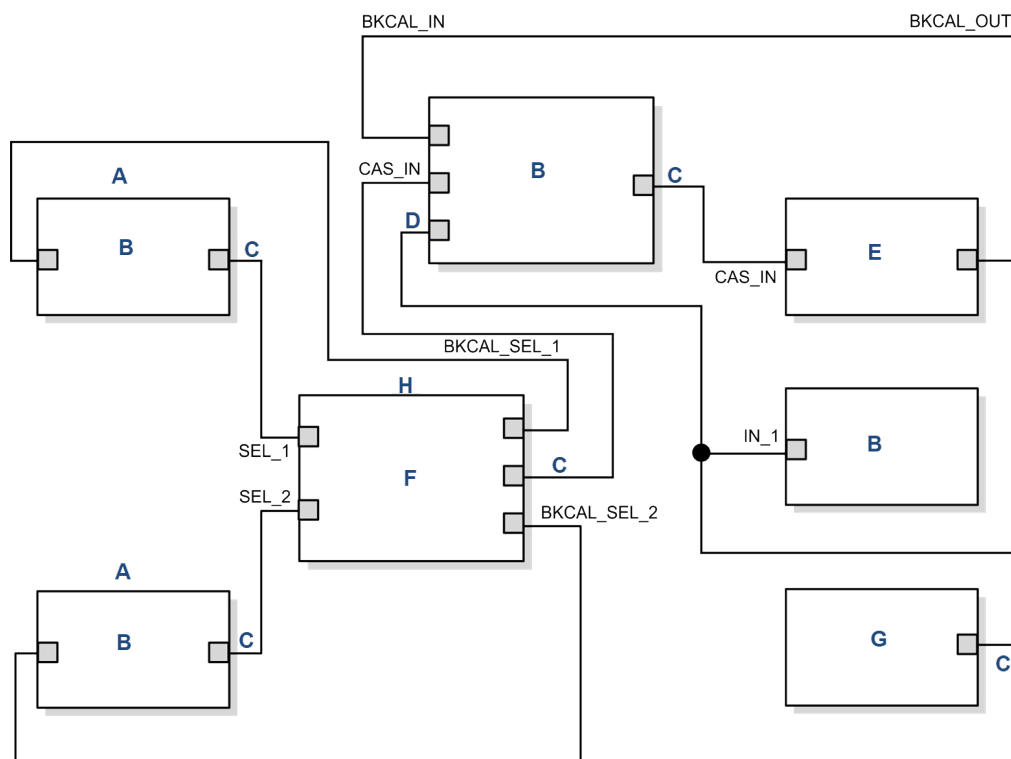

- A. Master controller
- B. PID function block
- C. Out
- D. In
- E. AO function block
- F. Control selector function block
- G. AI function block
- H. Slave controller

8.9.11 Troubleshooting

Refer to [Table 8-27](#) to troubleshoot any problems that you may encounter.

Table 8-27: Troubleshooting

Symptom	Possible causes	Corrective action
Mode will not leave OOS.	1. Target mode not set.	1. Set target mode to something other than OOS.

Table 8-27: Troubleshooting (continued)

Symptom	Possible causes	Corrective action
	2. Configuration error	2. BLOCK_ERR will show the configuration error bit set. The following are parameters that must be set before the block is allowed out of OOS: a. <i>BYPASS</i> must be off or on and cannot be left at the initial value of 0. b. OUT_HI_LIM must be less than or equal to OUT_LO_LIM . c. SP_HI_LIM must be less than or equal to SP_LO_LIM .
	3. Resource block	3. The actual mode of the resource block is OOS. See <i>Resource block diagnostics</i> for corrective action.
	4. Schedule	4. Block is not scheduled and therefore cannot execute to go to Target mode. Schedule the block to execute.
Mode will not leave IMAN .	Back calculation	BKCAL_IN a. The link is not configured (the status would show <i>Not connected</i>). Configure the BKCAL_IN link to the downstream block. b. The downstream block is sending back a Quality of Bad or a Status of Not Invited . See the appropriate downstream block diagnostics for corrective action.
Mode will not change to AUTO .	1. Target mode not set	1. Set target mode to something other than OOS.
	2. Input	2. IN a. The link is not configured (the status would show <i>Not connected</i>). Configure the IN link to the block. b. The upstream block is sending back a Quality of Bad or a Status of Not Invited . See the appropriate upstream block diagnostics for corrective action.
Mode will not change to CAS .	1. Target mode not set.	1. Set target mode to something other than OOS.
	2. Cascade input	2. CAS_IN a. The link is not configured (the status would show Not connected). Configure the CAS_IN link to the block. b. The upstream block is sending back a Quality of Bad or a Status of Not Invited . See the appropriate upstream block diagnostics for corrective action.
Mode sheds from RCAS to AUTO .	1. Remote cascade value	1. Host system is not writing RCAS_IN with a quality and status of <i>good cascade</i> within shed time (see 2 below).

Table 8-27: Troubleshooting (continued)

Symptom	Possible causes	Corrective action
	2. Shed timer	2. The mode shed timer, SHED_RCAS , in the resource block is shed too low. Increase the value.
Mode sheds form ROUT to MAN	1. Remote output value	1. Host system is not writing ROUT_IN with a quality and status of <code>good cascade</code> within shed time (see 2 below).
	2. Shed timer	2. The mode shed timer, SHED_RCAS , in the resource block is shed too low. Increase the value.
Process and/or block alarms will not work.	1. Features	1. FEATURES_SEL does not have Alerts enabled. Enable the Alerts bit.
	2. Notification	2. LIM_NOTIFY is not high enough. Set equal to MAX_NOTIFY .
	3. Status options	3. STATUS_OPS has Propagate Fault Forward bit set. This should be cleared to cause an alarm to occur.

Mode will not leave out of service (OOS)

See [Mode will not leave out of service \(OOS\)](#).

Mode will not leave IMAN

Potential cause

The link is not configured; the status shows **Not connected**.

Recommended action

Configure the **BKCAL_IN** link to the downstream block.

Potential cause

The downstream block is sending back a **Quality** of **Bad** or a **Status** of **Not Invited**.

Recommended action

See the appropriate downstream block diagnostics for corrective action.

Mode will not change to AUTO

Potential cause

Target mode not set.

Recommended action

Set target mode to something other than OOS.

Potential cause

The link is not configured; the status shows **Not connected**.

Recommended action

Configure the **IN** link to the block.

Potential cause

The upstream block is sending back a **Quality** of **Bad** or a **Status** of **Not Invited**.

Recommended action

See the appropriate upstream block diagnostics for corrective action.

Mode will not change to CAS

Potential cause

Target mode not set.

Recommended action

Set target mode to something other than OOS.

Potential cause

The link for Cascade input (**CAS_IN**) is not configured.

Recommended action

Configure the **CAS_IN** link to the block.

Potential cause

The upstream block is sending back a **Quality** of **Bad** or a **Status** of **Not Invited**.

Recommended action

See the appropriate upstream block diagnostics for corrective action.

Mode sheds from RCAS to AUTO

Potential cause

Host system is not writing **RCAS_IN** with a **Quality** and **Status** of good cascade within shed time. The mode shed timer, **SHED_RCAS**, in the resource block is shed too low.

Recommended action

Increase the value.

Mode sheds from ROUT to MAN

Potential cause

Host system is not writing **ROUT_IN** with a **Quality** and **Status** of good cascade within shed time. The mode shed timer, **SHED_RCAS**, in the resource block is shed too low.

Recommended action

Increase the value.

8.10 Arithmetic (ARTHM) function block

The arithmetic function block provides the ability to configure a range extension function for a primary input and applies the nine different arithmetic types as compensation to or

augmentation of the range extended input. All operations are selected by parameter and input connection.

Figure 8-24: Arithmetic (ARTHM) Function Block

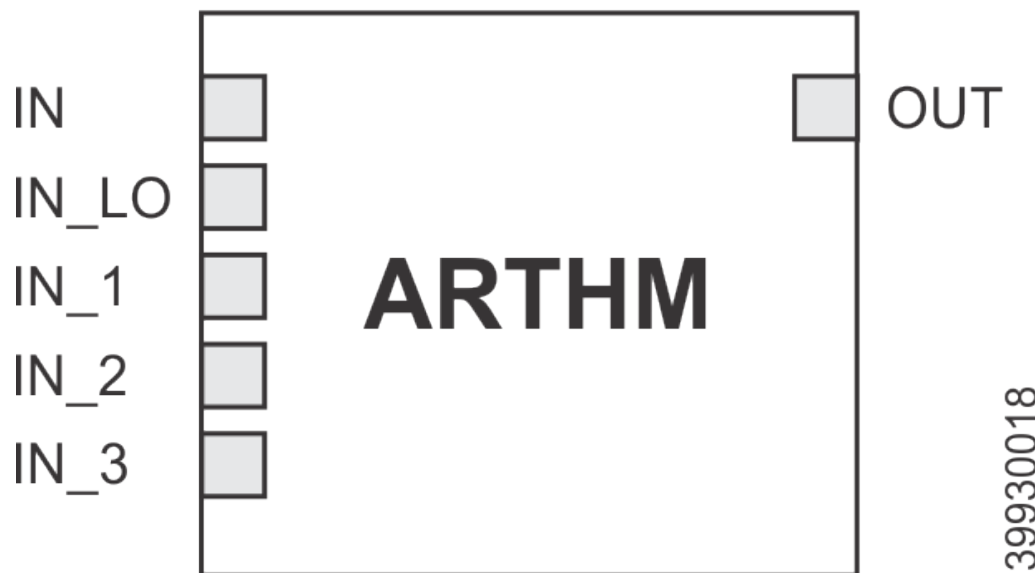

The nine arithmetic functions are: flow compensation linear, flow compensation square root, flow compensation approximate, BTU flow, traditional multiply and divide, average, summer, fourth order polynomial, and simple HTG compensate level.

This arithmetic function block supports mode control (Auto, Manual, or Out of Service). There is no standard alarm detection in this block.

Table 8-28: Arithmetic (ARTHM) Block

Index number	Parameter	Units	Description
4	ALERT_KEY	None	The identification number of the plant unit. This information may be used in the host for sorting alarms, etc.
29	ARITH_TYPE	None	The set of 9 arithmetic functions applied as compensation to or augmentation of the range extended input.
30	BAL_TIME	Seconds	Specifies the time for a block value to match an input, output, or calculated value or the time for dissipation of the internal balancing bias.
31	BIAS	None	The bias value.
21	BIAS_IN_1	None	The bias value for IN_1.
23	BIAS_IN_2	None	The bias value for IN_2.
25	BIAS_IN_3	None	The bias value for IN_3.

Table 8-28: Arithmetic (ARTHM) Block (continued)

Index number	Parameter	Units	Description
36	BLOCK_ALM	None	This block alarm is used for all configuration, hardware, connection failure, or system problems in the block. The cause of the alert is entered in the subcode field. The first alert to become active will set the Active status in the Status parameter. As soon as the Unreported status is cleared by the alert reporting task, another block alert may be reported without clearing the Active status, if the subcode has changed.
6	BLOCK_ERR	None	The summary of active error conditions associated with the block. The possible block errors are Block configuration error, Simulate active, Local override, Input failure/process variable has Bad status, Output failure, Readback failed, Out of service, and Other. Each function block reports none or a subset of these error conditions.
27	COMP_HI_LIM	EU of PV	Determines the high limit of the compensation input.
28	COMP_LO_LIM	EU of PV	Determines the low limit of the compensation input.
32	GAIN	None	The proportional gain (multiplier) value.
22	GAIN_IN_1	None	The proportional gain (multiplier) value for IN_1.
24	GAIN_IN_2	None	The proportional gain (multiplier) value for IN_2.
26	GAIN_IN_3	None	The proportional gain (multiplier) value for IN_3.
12	GRANT_DENY	None	Options for controlling access of host computers and local control panels to operating, tuning, and alarm parameters of the block. Not used by the transmitter.
14	IN	Determined by source or EU of PV_SCALE	The analog input value and status. The number of inputs is an extensible parameter in some function blocks.
16	IN_1	Determined by supplying block or source.	The first analog input value and status.
17	IN_2	Determined by supplying block or source.	The second analog input value and status.
18	IN_3	Determined by supplying block or source.	The third analog input value and status.
15	IN_LO	None	The value used for the input whenever IN is below range.

Table 8-28: Arithmetic (ARTHM) Block (continued)

Index number	Parameter	Units	Description
13	INPUT_OPTS	None	Sets the options for using IN, IN_LO, IN_1, IN_2, and IN_3 when any are either Bad or Uncertain.
5	MODE_BLK	None	The mode record of the block. MODE contains the actual, target, permitted, and normal modes. In some function blocks, this parameter is used to request and show the source of the setpoint, the source of the output, and/or the block operating state.
8	OUT	EU of OUT_SCALE or Percent or EU of IN	The analog output value and status. The number of outputs is an extensible parameter in some blocks.
33	OUT_HI_LIM	EU of OUT_SCALE supplied by IN	The maximum output value allowed.
34	OUT_LO_LIM	EU of OUT_RANGE or Supplied by IN	The minimum output value allowed.
11	OUT_RANGE	None	Range of the output.
9	PRE_OUT	EU of OUT	The pre-trip limit from SP or zero.
7	PV	EU of OUT of EU of PV_SCALE	The process variable used in block execution and alarm limit detection.
10	PV_SCALE	None	The high and low scale values, engineering units code, and number of digits to the right of the decimal point associated with OUT.
19	RANGE_HI	None	The high limit for IN.
20	RANGE_LO	None	The low limit for IN. If IN is less than RANGE_LO, then IN_LO is used.
3	STRATEGY	None	The Strategy field can be used to identify grouping of blocks. This data is not checked or processed by the block.
1	ST_REV	None	The revision level of the static data associated with the function block. The revision value will be incremented each time a static parameter value in the block is changed.
2	TAG_DESC	None	The user description of the intended application of the block.
35	UPDATE_EVT	None	This alert is generated by any changes to the static data.

Figure 8-25: Arithmetic function block diagram

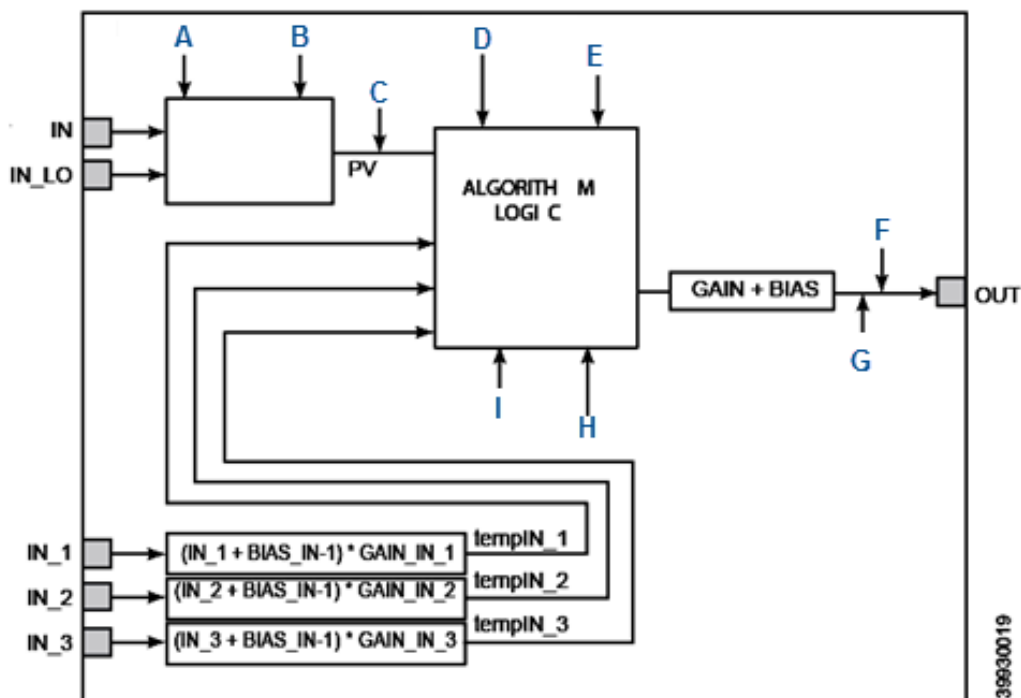

- A. RANGE LO
- B. RANGE HI
- C. PV UNIT
- D. ARITH_TYPE
- E. BAL_TIME
- F. OUT_HI_LIM
- G. OUT_LO_LIM
- H. OUT_LO_LIM
- I. OUT_LO_LIM

8.10.1 Block errors

Table 8-29 lists conditions reported in the BLOCK_ERR parameter.

Table 8-29: BLOCK_ERR Conditions

Condition number	Condition name and description
0	Other
1	Block Configuration Error: The BY_PASS parameter is not configured and is set to 0 , the SP_HI_LIM is less than the SP_LO_LIM , or the OUT_HI_LIM is less than the OUT_LO_LIM .
2	Link Configuration Error
3	Simulate Active
4	Local Override: The actual mode is LO .

Table 8-29: BLOCK_ERR Conditions (continued)

Condition number	Condition name and description
5	Device Fault State Set
6	Device Needs Maintenance Soon
7	Input Failure/Process Variable has Bad Status: The parameter linking to IN is indicating a Bad status.
8	Output Failure
9	Memory Failure
10	Lost Static Data
11	Lost NV Data
12	Readback Check Failed
13	Device Needs Maintenance Now
14	Power Up
15	Out of Service: The actual mode is out of service.

8.10.2 Modes

The ARTHM block supports the following modes:

- Manual (Man): The block output (OUT) may be set manually.
- Automatic (Auto): OUT reflects the analog input measurement or the simulated value when simulation is enabled.
- Out of Service (O/S): The block is not processed. **FIELD_VAL** and PV are not updated, and the **OUT** status is set to **Bad: Out of Service**. The **BLOCK_ERR** parameter shows **Out of Service**. In this mode, you can make changes to all configurable parameters.

The target mode of a block may be restricted to one or more of the supported modes.

8.10.3 Alarm detection

A block alarm is generated whenever the BLOCK_ERR has an error bit set.

Block errors defines the types of block errors for the arithmetic block. Alarms are grouped into five levels of priority:

Priority number	Priority description
0	The priority of an alarm condition changes to 0 after the condition that caused the alarm is corrected.
1	An alarm condition with a priority of 1 is recognized by the system, but is not reported to the operator.
2	An alarm condition with a priority of 2 is reported to the operator, but does not require operator attention (such as diagnostics and system alerts).
3-7	Alarm conditions of priority 3 through 7 are advisory alarms of increasing priority.
8-15	Alarm conditions of priority 8 to 15 are critical alarms of increasing priority.

8.10.4 Block execution

The arithmetic function block provides range extension and compensation through nine arithmetic types.

There are two inputs (**IN** and **IN_LO**) used in calculating PV. PV is then combined with up to three inputs (**IN_1**, **IN_2**, and **IN_3**) through the user selected compensation function (**ARITH_TYPE**) to calculate the value of func., and then a bias is added to get the value **PRE_OUT**. In **AUTO**, **PRE_OUT** is used for **OUT**.

Range extension and calculation of PV

When both **IN** and **IN_LO** are usable, the following formula is applied to calculate range extension for PV:

$$PV = G * IN + (1-G) * IN_LO$$

(G has a range from 0 to 1, for IN from **RANGE_LO** to **RANGE_HI**.)

8.10.5 Compensation input calculations

For each of the inputs **IN_1**, **IN_3**, and **IN_4**, there is a gain and a bias. The compensation terms (t) are calculated as follows:

- When **IN_(k)** is usable: $t(k) = \mathbf{GAIN_IN(k)} * (\mathbf{BIAS_IN(k)} + \mathbf{IN_(k)})$
- When **IN_(k)** is not usable, then t(k) gets the value of the last t(k) computed with a usable input.

Status handling

- **IN_x** Use Bad
- **IN_x** Use Uncertain
- **IN_LO** Use Uncertain
- **IN** Use Uncertain

For complete descriptions of supported input options, refer to the **Options Bitstring** parameter.

8.10.6 Application information

The arithmetic function block can be used to calculate tank level changes based on greatly changing temperature conditions in devices that depend on the physical properties of the fluid.

For example, a differential pressure cell's analog input can be scaled initially to provide a 4-20 mA signal for 0 -100% of level indication. As the temperature of the system rises, the density of the fluid decreases. For a system that requires accurate level indication at widely ranging temperature, changing density proves inconvenient.

The arithmetic function block allows for the automatic compensation of this change by incorporating gain and bias adjustments to the temperature signal. It then applies both the compensated temperature signal and the level signal to a characteristic system equation. The result is a level that is a true indication of fluid in the vessel.

Different fluids over the same temperature range have different effects on level due to their thermal expansion coefficients. Vessel geometry also plays a major role. As the height of the vessel increases, the effect of thermal expansion becomes more apparent. [Figure 8-26](#) shows the relative temperature effects on a level signal.

Figure 8-26: Relative Temperature Effects on Level

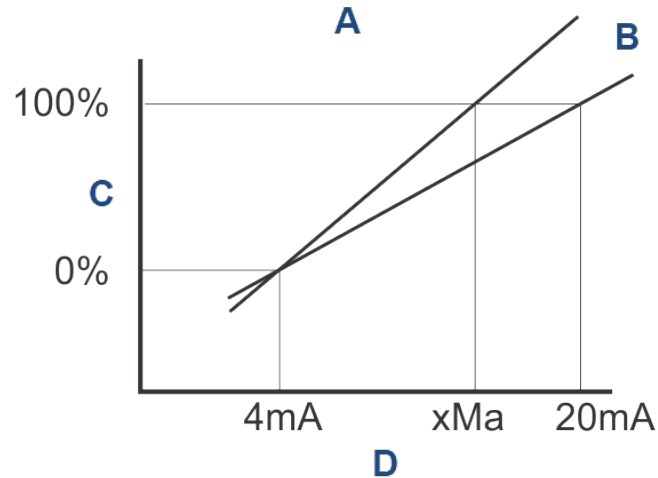

39930020

- A. Elevated temperature level
- B. Indicated level calibrated at ambient temperature
- C. Level percent
- D. Milliamp signal

This calculation is done by applying the level signal to the **IN** connector, the liquid temperature to the **IN_1** connector, and the ambient air temperature to the **IN_2** connector. Select the arithmetic type (**ARITH_TYPE**) of flow compensation - linear.

This allows a ratio to be set up that increases the level indication at a block output for an increase in the tank temperature relative to ambient temperature.

Figure 8-27: Arithmetic Function Block Diagram Example

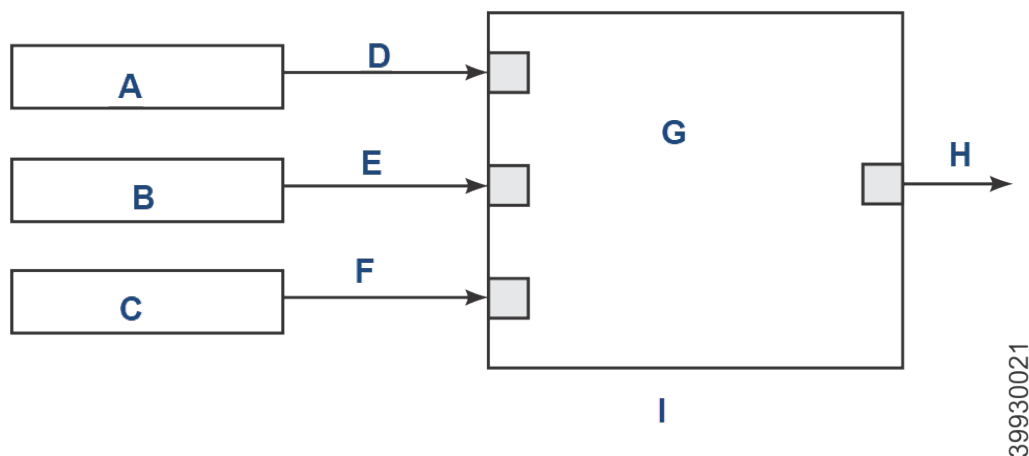

- A. Tank level
- B. Liquid temperature
- C. Air temperature
- D. In
- E. In_1
- F. In_2
- G. Arithmetic block
- H. Out
- I. Arithmetic type = flow comp-linear

This application can be applied to very large storage tanks whose contents are subject to thermal expansion and contraction during seasonal changes in temperature.

8.11 Advanced topics

8.11.1 Arithmetic types

The parameter **ARITH_TYPE** determines how PV and the compensation terms (t) are combined. You may select from nine commonly used math functions depicted below. **COMP_HI** and **COMP_LO** are compensation limits.

Flow Compensation Linear	Flow Compensation Square Root
$\text{func} = \text{PV} \cdot f$ <p>COMP_HI</p> $f = \frac{t(1)}{t(2)}$ <p>COMP_LO</p>	$\text{func} = \text{PV} \cdot f$ <p>COMP_HI</p> $f = \sqrt{\frac{t(1) \cdot t(3)}{t(2)}}$ <p>COMP_LO</p>

39930022

If there is a divide by zero and the numerator is positive, f is set to **COMP_HI**; if the numerator is negative, then f is set to **COMP_LO**.

The square root of a negative value will equal the negative of the square root of the absolute value. Imaginary roots are not supported.

Flow Compensation Approximate	BTU Flow	Traditional Multiply and Divide
func = PV · f	func = PV · f	func = PV · f
COMP_HI	COMP_HI	COMP_HI
$f = t(1) \cdot t(2) \cdot t(3)^2$	$f = t(1) - t(2)$	$f = \frac{t(1)}{t(2)} + t(3)$
COMP_LO	COMP_LO	COMP_LO

If there is a divide by zero and the numerator is positive, f will be limited to **COMP_HI**; if the numerator is negative, f will be limited to **COMP_LO**. Compensation inputs which are not usable are not included in the calculation. PV is always included.

8.11.2 Troubleshoot

8.12 Input selector (ISEL) function block

The input selector (ISEL) function block can be used to select the first good, hot backup, maximum, minimum, or average of as many as four input values and place it at the output.

The block supports signal status propagation. There is no process alarm detection in the input selector function block.

Figure 8-28: Input Selector (ISEL) Function Block

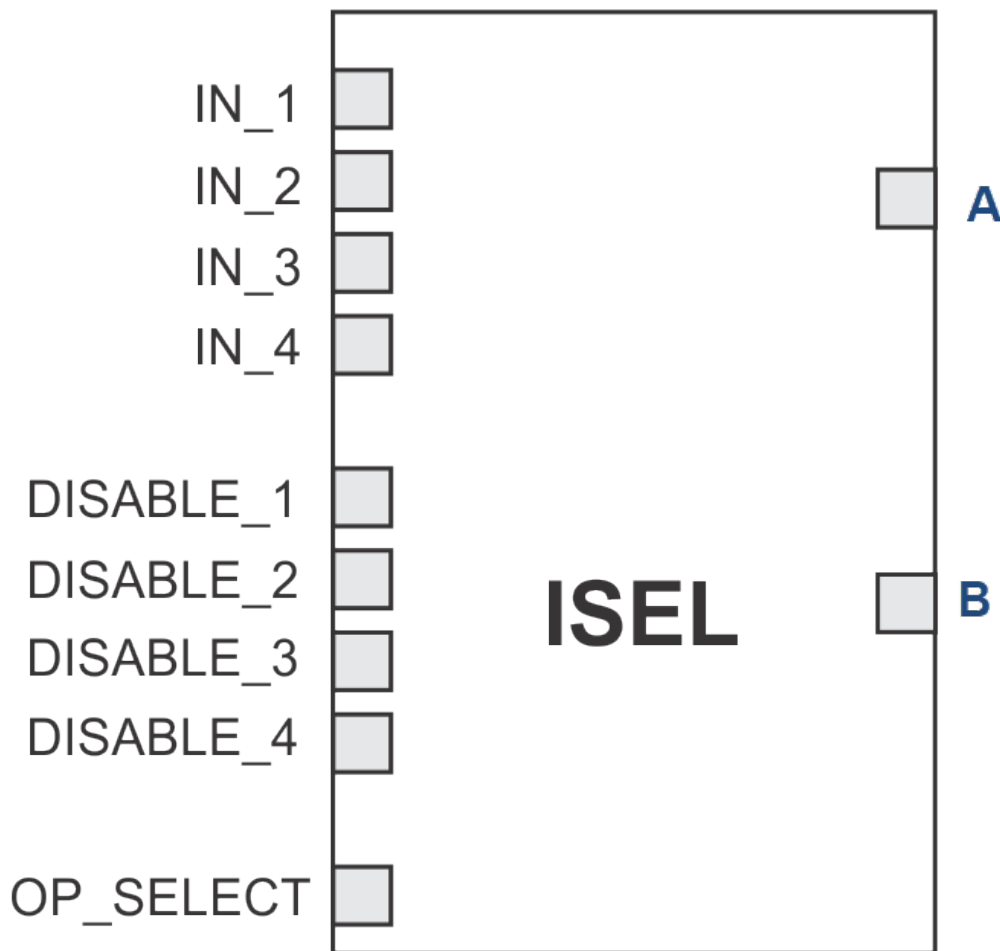

A. Out
B. Selector

- IN (1-4) = Input used in the selected algorithm.
- DISABLE (1-4) = Discrete input used to enable the associated input channel.
- OP_SELECT = Input used to override algorithm.
- TRK_VAL = The value after scaling applied to OUT in local channel override.
- SELECTED = The selected channel number.
- OUT = The block output and status.

Figure 8-28 illustrates the internal components of the ISEL block. Table 8-30 lists the ISEL block parameters and their descriptions, units of measure, and index numbers.

Table 8-30: Input Selector Function Block System Parameters

Parameter name	Index number	Units	Description
ALERT_KEY	4	None	The identification number of the plant unit. This information may be used in the host for sorting alarms, etc.
BLOCK_ALM	24	None	The block alarm is used for all configuration, hardware, connection failure, or system problems in the block. The cause of the alert is entered in the Subcode field. The first alert to become active will set the Active status in the Status parameter. As soon as the Unreported status is cleared by the alert reporting task, another block alert may be reported without clearing the Active status if the subcode has changed.
BLOCK_ERR	6	None	This parameter reflects the error status associated with the hardware or software components associated with a block. It is a bit string, so that multiple errors may be shown.
DISABLE_1	15	None	A connection from another block that disables the associated input from the selection.
DISABLE_2	16	None	A connection from another block that disables the associated input from the selection.
DISABLE_3	17	None	A connection from another block that disables the associated input from the selection.
DISABLE_4	18	None	A connection from another block that disables the associated input from the selection.
GRANT_DENY	9	None	Options for controlling access of host computers and local control panels to operating, tuning, and alarm parameters of the block. Not used by transmitter.
IN_1	11	Determined by source	The connection input from another block. One of the inputs to be selected from.
IN_2	12	Determined by source	The connection input from another block. One of the inputs to be selected from.
IN_3	13	Determined by source	The connection input from another block. One of the inputs to be selected from.
IN_4	14	Determined by source	The connection input from another block. One of the inputs to be selected from.
MIN_GOOD	20	None	The minimum number of good inputs. The actual, target, permitted, and normal modes of the block. Target: The mode to go to. Actual: the mode the block is currently in. Permitted: Allowed mode that target may take on. Normal: Most common mode for target.
OP_SELECT	22	None	Overrides the algorithm to select 1 of the 4 inputs regardless of the selection type.
OUT	7	EU of IN	The block output value and status.
OUT_UNITS	8	None	The engineering units of the output. Typically, all inputs have the same units, and the value is also the same.

Table 8-30: Input Selector Function Block System Parameters (continued)

Parameter name	Index number	Units	Description
SELECTED	21	None	The selected input number (1-4).
SELECT_TYPE	19	None	Specifies selection method (see Block Execution).
STATUS_OPTS	10	None	Allows selection of options for status handling and processing. The supported status option for the PID block is Target to Manual if Bad IN.
STRATEGY	3	None	The Strategy field can be used to identify grouping of blocks. This data is not checked or processed by the block.
ST_REV	1	None	The revision level of the static data associated with the function block. The revision value will be incremented each time a static parameter value in the block is changed.
TAG_DESC	2	None	The user description of the intended application of the block.
UPDATE_EVT	23	None	This alert is generated by any change to the static data.

Figure 8-29: Input Selector Function Block Schematic

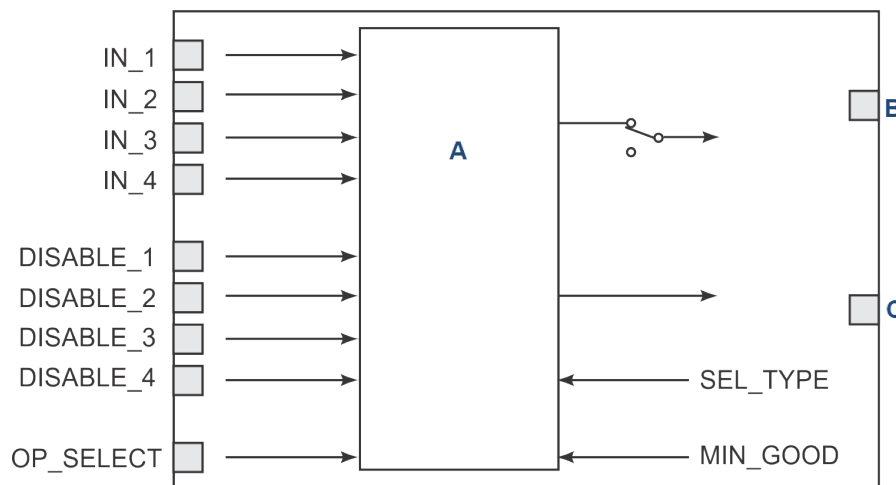

39930025

- A. Selection algorithm
- B. Out
- C. Selector

8.12.1 Block errors

Table 8-31 lists the conditions reported in the **BLOCK_ERR** parameter.

Table 8-31: Block Error Conditions

Condition number	Condition name and description
0	Other: The output has a quality of Uncertain .

Table 8-31: Block Error Conditions (continued)

Condition number	Condition name and description
1	Block Configuration Error
2	Link Configuration Error
3	Simulate Active
4	Local Override: The actual mode is LO .
5	Device Fault State Set
6	Device Needs Maintenance Soon
7	Input Failure/Process Variable has Bad Status: One of the inputs is bad or not connected.
8	Output Failure: The output has the quality of Bad .
9	Memory Failure: A memory failure has occurred in FLASH, RAM or EEROM memory.
10	Lost Static Data
11	Lost NV Data
12	Readback Check Failed
13	Device Needs Maintenance Now
14	Power Up: The device was just powered up.
15	Out of Service: The actual mode is out of service.

8.12.2 Modes

The ISEL function block supports three modes of operation as defined by the **MODE_BLK** parameter:

- Manual (Man): The block output (OUT) may be set manually.
- Automatic (Auto): OUT reflects the analog input measurement or the simulated value when simulation is enabled.
- Out of service (O/S): The block is not processed. The **BLOCK_ERR** parameter shows **Out of Service**. In this mode, you can make changes to all configurable parameters. The target mode of a block may be restricted to one or more of the supported modes.

8.12.3 Alarm detection

A block alarm will be generated whenever the BLOCK_ERR has an error bit set. The types of block error for the ISEL block are defined above.

Alarms are grouped into five levels of priority, [Table 8-32](#).

Table 8-32: Alarm Priorities

Priority number	Priority description
0	The priority of an alarm condition changes to 0 after the condition that caused the alarm is corrected.
1	An alarm condition with a priority of 1 is recognized by the system, but is not reported to the operator.

Table 8-32: Alarm Priorities (continued)

Priority number	Priority description
2	An alarm condition with a priority of 2 is reported to the operator, but does not require operator attention (such as diagnostics and system alerts).
3-7	Alarm conditions of priority 3 through 7 are advisory alarms of increasing priority.
8-15	Alarm conditions of priority 8 to 15 are critical alarms of increasing priority.

8.12.4 Block execution

The ISEL function block reads the values and statuses of as many as four inputs. To specify which of the six available methods (algorithms) is used to select the output, configure the selector type parameter (**SEL_TYPE**) as follows:

- **max** selects the maximum value of the inputs.
- **min** selects the minimum value of the inputs.
- **avg** calculates the average value of the inputs.
- **mid** calculates the middle of three inputs or the average of the middle two inputs if four inputs are defined.
- **1st Good** selects the first available good input.
- **Hot Backup** latches on the selected input and continues to use it until it is bad.

If **DISABLE_N** is active, the associated input is not used in the selected algorithm.

If **OP_SELECT** is set to a value between 1 and 4, the selection type logic is overridden, and the output value and status are set to the value and status of the input selected by **OP_SELECT**.

SELECTED will have the number of the selected input unless the **SEL_TYPE** is average, in which case it will have the number of inputs used to calculate its value.

8.12.5 Status handling

In **Auto** mode, **OUT** reflects the value and status quality of the selected input. If the number of inputs with **Good** status is less than **MIN_GOOD**, the output status will be **BAD**.

In **Man** mode, the **OUT** status high and low limits are set to indicate that the value is constant, and the **OUT** status is always **Good**.

In the **STATUS_OPTS** parameter, the following options can be selected to control the status handling:

- Use Uncertain as Good: Sets the **OUT** status quality to **Good** when the selected input status is **Uncertain**.
- Uncertain if in Manual mode: The status of the Output is set to **Uncertain** when the mode is set to **Manual**.

⚠ CAUTION

Set the system in **Manual** or **Out of Service** mode to set the **Status** option.

8.12.6 Application information

The input selector (ISEL) function block can be used to select the maximum temperature input from four inputs and send it to a proportional/integral/derivative (PID) function block to control a process water chiller (Figure 8-30) or it can use the block to calculate the average temperature of the four inputs (Figure 8-31).

Figure 8-30: Input Selector Function Block Application Example (SEL_TYPE = max)

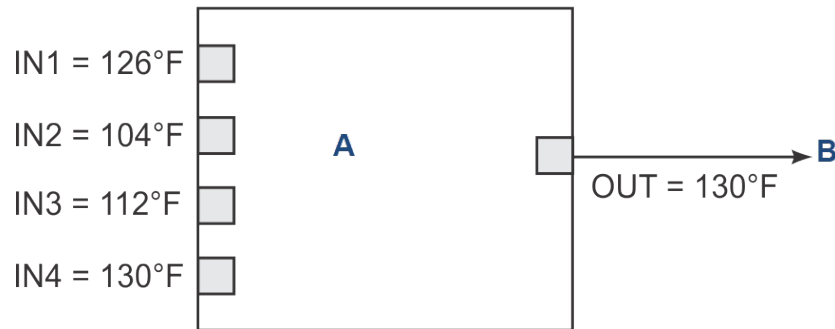

39930018

- A. Input selector (ISEL) function block
- B. To another function block

Figure 8-31: Input Selector Function Block Application Example (SEL_TYPE = avg)

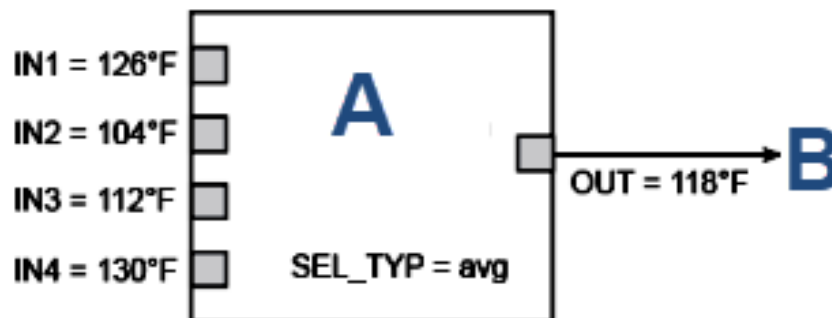

39930027

- A. Input selector (ISEL) function block
- B. To another function block

Figure 8-32: Input Selector Function Block Example (SEL_TYPE = Hot Backup)

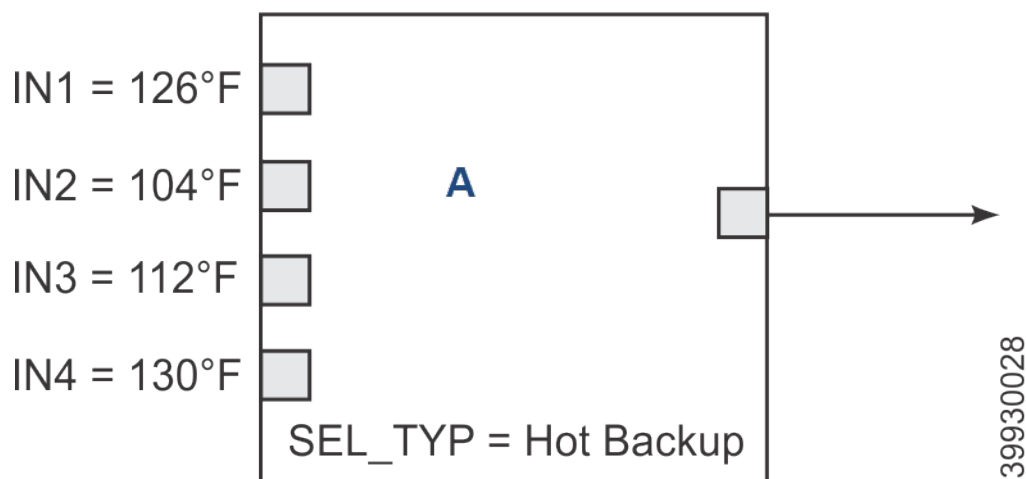

A. Input selector (ISEL) function block

Table 8-33: Input Selector Function Blocks

Time	IN1 value	Status	IN2 value	Status	Out value	Status	Selected value	Status
T ₀	Good	20	Good	21	Good	20	Good	1
T ₁	Bad	20	Good	21	Good	21	Good	2
T ₂	Good	20	Good	21	Good	21	Good	21

8.12.7 Troubleshoot

8.13 Operation with Emerson DeltaV™

8.13.1 Install a new device onto a DeltaV™ system

AMS and DeltaV software allows you to manage your instrumentation and to perform on-line configurations of your instruments.

The ability to communicate with instruments and configure instruments on-line facilitates instrument commissioning and loop validation.

With AMS, you can also access status and diagnostic data from smart devices and monitor their performance.

AMS leverages the I/O capabilities of the control system to gather asset management data without interfering with the control system's operations.

Before starting this procedure, install DeltaV and the transmitter and power them on.

1. Insert the transmitter onto DeltaV.
2. From the **Start** menu, select **DeltaV** → **Engineering** → **DeltaV Explorer**.
3. Select/expand Library (right below DeltaV system).

4. Right-click **Fieldbus Devices**. This brings up a list of options.
5. From the list, select **Add Device Definition**. This opens a **Browse for folder** dialog box. Browse to the directory that contains the seven files needed to register a new device with DeltaV. These files consist of 3 *.dll files, *.sym, *.ffo, *.fhx, and *.reg files. The files are probably on a floppy disk or a CD-ROM that accompanies your device. On CD-ROMs delivered together with Emerson transmitters the files are located in the directory **/Fieldbus**. Dependent on the existing system, use the files of the appropriate subdirectory.
6. Answer **Yes** to the first prompt. DeltaV starts the installation.

Figure 8-33 shows the **Exploring DeltaV** screen for reference.

Figure 8-33: DeltaV Explorer

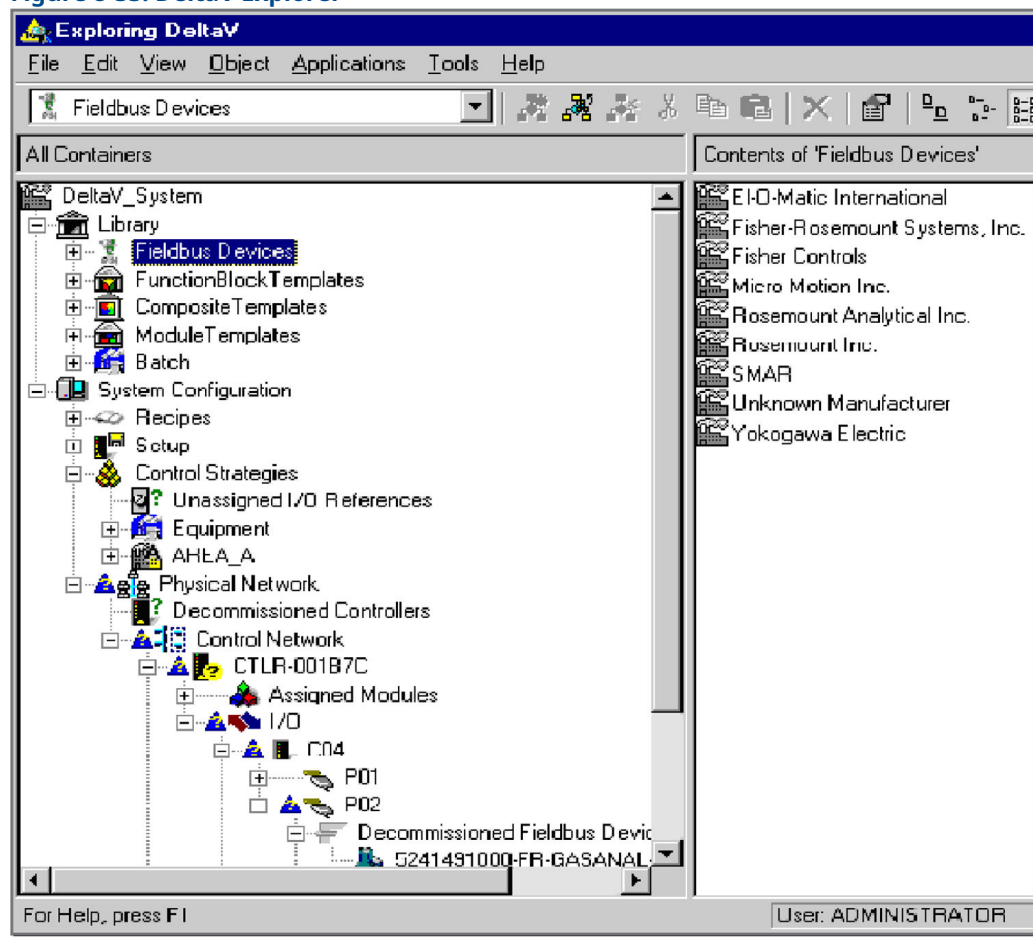

9 Troubleshoot

⚠ WARNING

Electric shock

Failure to install covers and ground leads could result in serious injury or death.
Install all protective equipment covers and safety ground leads after troubleshooting.

9.1 Overview

This troubleshooting section describes how to identify and isolate faults that may develop in the transmitter. When troubleshooting the transmitter, reference the following information.

9.1.1 Grounding

It is essential that adequate grounding precautions are taken when installing the system. Thoroughly check both the probe and electronics to ensure the grounding quality has not degraded during fault finding. The system provides facilities for 100 percent effective grounding and total elimination of ground loops.

9.1.2 Electrical noise

Emerson designed the analyzer to operate in an environment normally found in a boiler room or control room.

Noise suppression circuits are employed on all field terminations and main inputs. When fault finding, evaluate the electrical noise being generated in the immediate circuitry of a faulty system. Ensure all cable shields are connected to earth.

9.1.3 Electrostatic discharge

⚠ CAUTION

Electrostatic discharge can damage ICs in the electronics.

Before removing or handling the processor board or the ICs, ensure you are at ground potential.

9.1.4 Total power loss

In the event that the transmitter will not power up at all, check the incoming power supply to make sure power is being delivered to the transmitter.

If the incoming power supply is good, then check fuses F1 and F6 in the electronics housing. Refer to [Figure 9-1](#) for fuse locations.

Figure 9-1: Fuse Locations

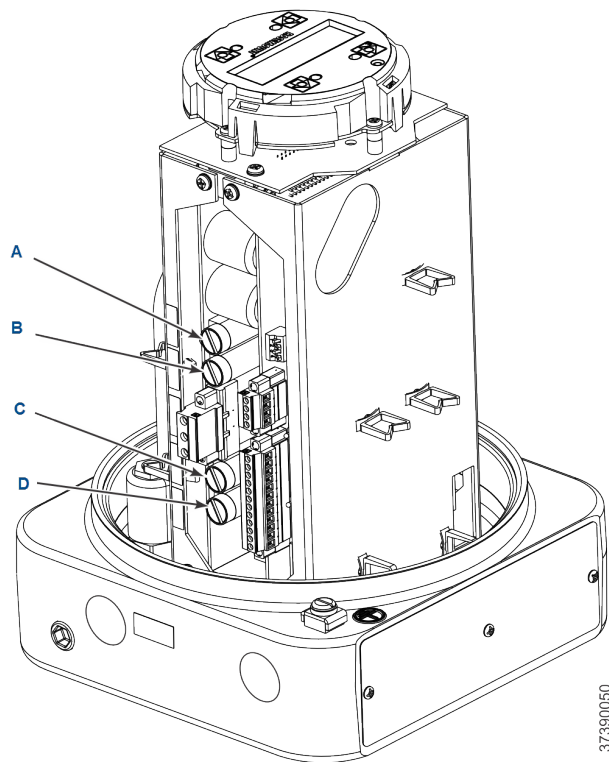

- A. F6
Neutral (N)
10 Amp, 250 Vac
- B. F1
Line (L1)
10 Amp, 250 Vac
- C. F3
O₂ and COe heater
4 Amp, 250 Vac
- D. F4
Sample block heater
8 Amp, 250 Vac

9.2 Diagnostic alarms

⚠ CAUTION

Electronics failure

Failure to install a blocking diode may create noise spikes and cause faults in the electronics.

Always install a blocking diode on the customer's relay coil.

The transmitter is equipped with a set of alarm relay contacts on the microprocessor board in the electronics housing. You can connect this set of dry contacts to any customer supplied relay device, 30 Vdc, 30 mA maximum. A blocking diode is required on the customer's relay coil.

Any fault condition in the transmitter will trip the alarm relay. The optional SPA with HART® programmable alarm indicates **LOW O2**, **HIGH COe**, **Calibration Status**, and **Unit Failure**. For more information, refer to [SPA with HART® alarm](#).

9.3 Fault isolation

Faults in the transmitter are indicated by messages displayed on the Field Communicator or local operator interface (LOI).

If a fault is indicated on the Field Communicator or LOI, locate the fault indication in the following sections. For each fault listed, there are related potential causes and recommended actions. The potential causes are listed in order of most probable to least probable. Starting with the most probable cause, inspect and test the transmitter to isolate the actual cause; then use the recommended corrective action listed to correct the problem.

Figure 9-2: Electrical Connections between Electronics and Sensor Housing

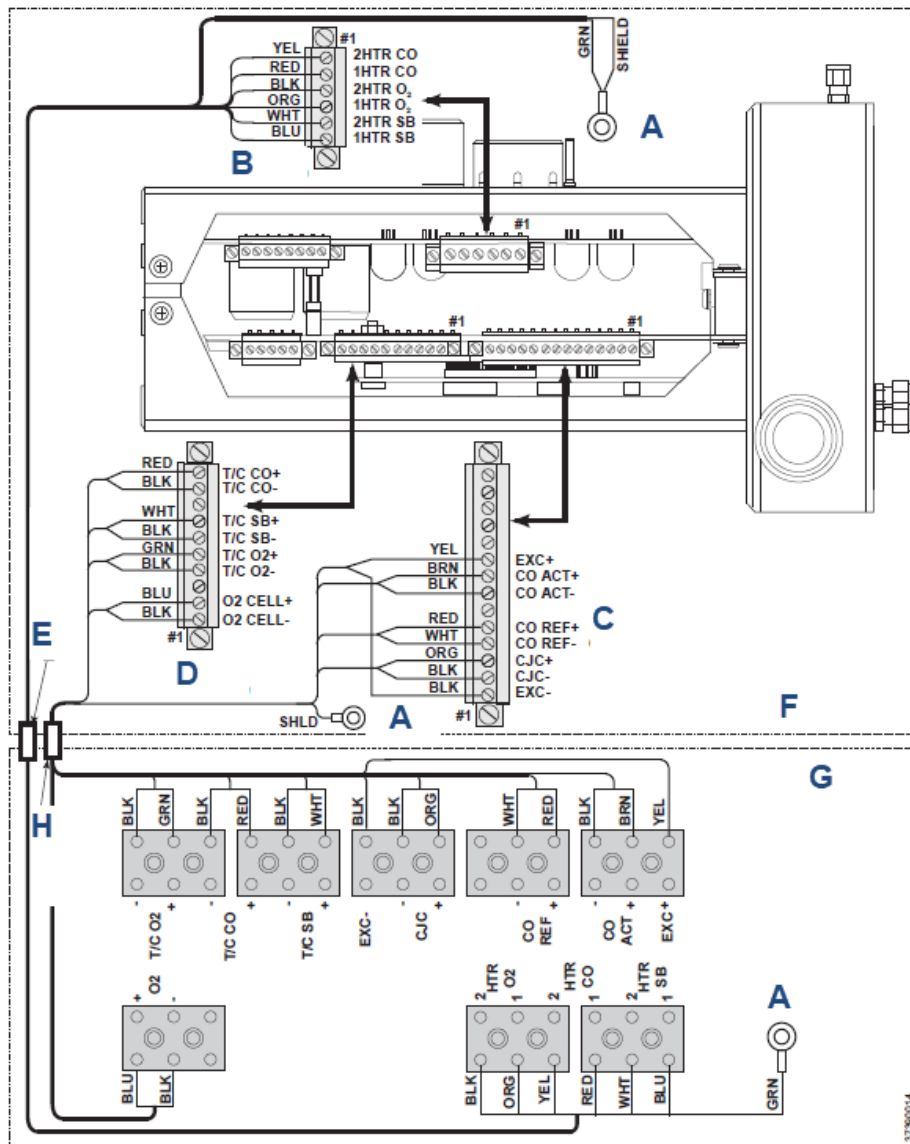

- A. To ground screw
- B. Heater power connector (J3)
- C. COe sensor and cold junction connector (J4)
- D. O₂ sensor and thermocouple connector (J5)
- E. Heater power cable
- F. Electronics housing
- G. Sensor housing
- H. Signal cable

Table 9-1: J3 Connections

Wire color	Connects to
Yellow	2 heater CO

Table 9-1: J3 Connections (continued)

Wire color	Connects to
Red	1 heater CO
Black	2 heater O ₂
Orange	1 heater O ₂
White	2 heater sample block
Blue	1 heater sample block
Green	Shield

Table 9-2: J4 Connections

Wire color	Connects to
Yellow	Execute+
Brown	CO act+
Black	CO act-
Red	CO reference+
White	CO reference-
Orange	Cold junction connector (CJC)+
Black	CJC-
Black	Execute-

Table 9-3: J5 Connections

Wire color	Connects to
Red	Thermocouple (T/C) CO+
Black	T/C CO-
White	T/C sample block (SB)+
Black	T/C SB-
Green	T/C O ₂ +
Black	T/C O ₂ -
Blue	O ₂ cell+
Black	O ₂ cell-

Figure 9-3: Oxygen and Cell Output

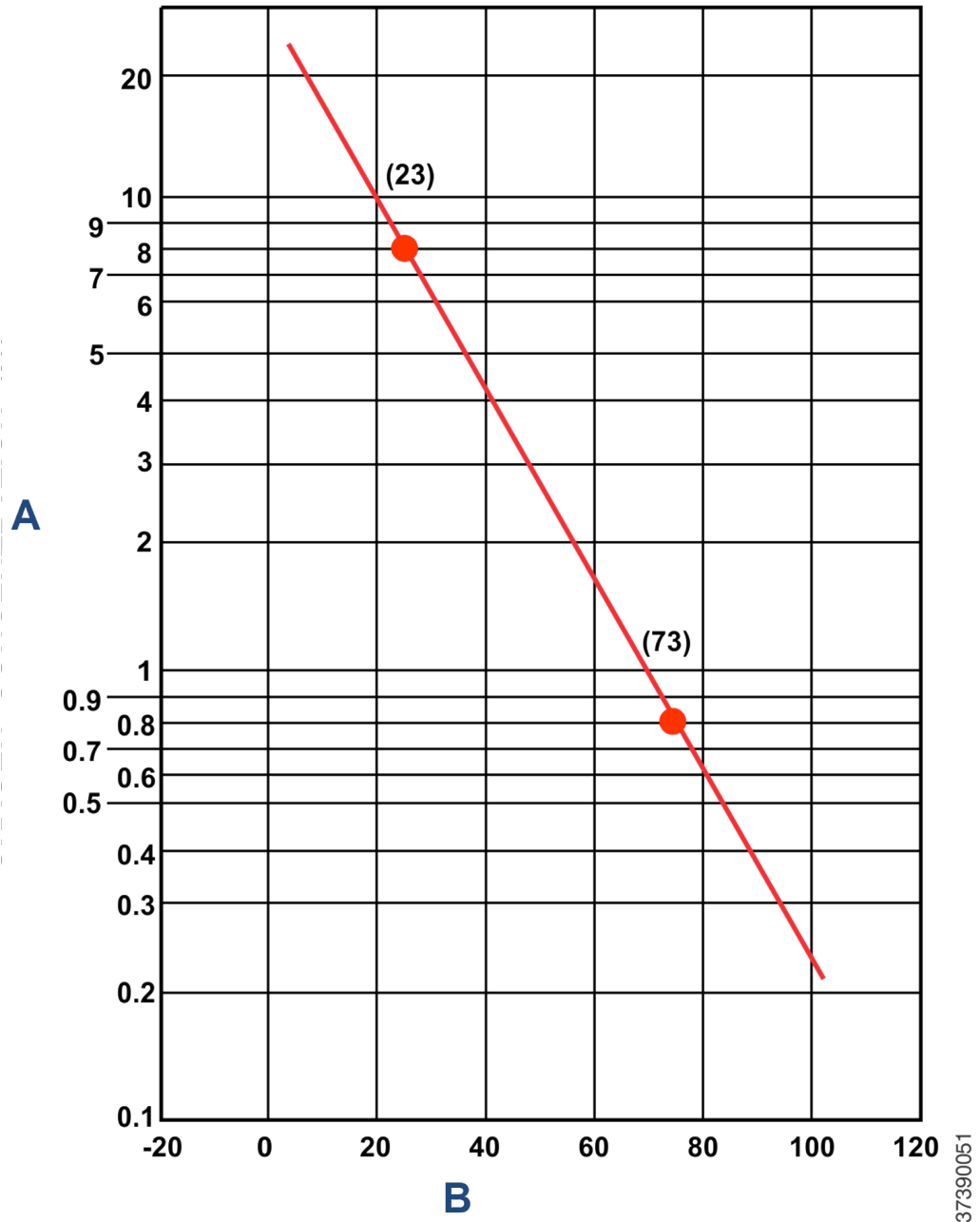

A. Oxygen concentration (percentage)
B. Transmitter output (millivolt)

9.3.1

O₂ Sensor R High or O₂ Sensor Open

Oxygen sensor resistance high, > 5000 ohms or oxygen sensor disconnected.

Potential cause

Loose or open O₂ cell circuit connection.

Recommended actions

1. Check O₂ cell circuit wires for breaks or loose connections.
2. Repair lead wire breaks or loose connections.

Potential cause

O₂ cell degraded or failed.

Recommended action

Check O₂ cell impedance by reading the O₂ Cell Imped value via the local operator interface (LOI) (see [Figure 4-4](#)) or the O₂ Snsr R value via HART® (see [Figure 5-3](#)).

- If cell impedance is zero, replace O₂ cell with cell replacement kit.
- If cell impedance is less than 5000 ohms, check for cell housing ground fault. Repair ground fault.
- If cell impedance is greater than 5000 ohms and no ground fault is indicated, replace O₂ cell with cell replacement kit.

9.3.2 Ref Current Err

Resistance temperature device (RTD) excitation current error. Reference current should be 5.02 mA.

Potential cause

Loose or open lead or circuit wire connection for COe sensor or cold junction connector (CJC) sensor current loop.

Recommended actions

1. Check all COe and CJC sensor current loop wiring per [Figure 9-2](#) and [Figure 10-9](#).
2. Correct wiring faults.

Potential cause

COe sensor grounded.

Recommended actions

1. Check resistance of COe sensor leads to ground per [Figure 10-9](#).
2. Replace COe sensor if resistance is less than 10M ohms.

Potential cause

COe sensor failed.

Recommended actions

1. Check resistance of both COe sensor elements per [Figure 10-9](#).
2. Replace COe sensor if resistance of sensor element is not between 100 and 250 ohms.

Potential cause

CJC sensor grounded.

Recommended actions

1. Check resistance of CJC sensor to ground per [Figure 10-9](#).
2. Replace CJC sensor if resistance is less than 10M ohms.

Potential cause

CJC sensor failed.

Recommended actions

1. Check resistance CJC sensor per [Figure 10-9](#).
2. Replace CJC sensor if resistance of sensor element is not between 100 and 150 ohms.

9.3.3 O₂ Temp Hi

Oxygen sensor heater temperature high, > 1381 °F (750 °C).

Potential cause

High noise in Rosemount OCX8800 power supply.

Recommended actions

1. Check power supply for line noise or voltage fluctuations.
2. Install power line filter kit (PN 6A00171G01) or high quality line filter for input power.

9.3.4 CO_e Temp Hi

Combustion sensor heater temperature high, > 590 °F (310 °C).

Potential cause

High noise in Rosemount OCX8800 power supply.

Recommended actions

1. Check power supply for line noise or voltage fluctuations.
2. Install power line filter kit (PN 6A00171G01) or high quality line filter for input power.

9.3.5 SB Temp Hi

Sample block heater temperature high, > 374 °F (190 °C).

Potential cause

High noise in Rosemount OCX8800 power supply.

Recommended actions

1. Check power supply for line noise or voltage fluctuations.
2. Install power line filter kit (PN 6A00171G01) or high quality line filter for input power.

9.3.6 O₂ Temp Very Hi or O₂ Htr Rmp Rate

Oxygen sensor heater over maximum temperature, > 1508 °F (820 °C) or oxygen sensor heater over maximum temperature ramp rate.

Potential cause

Incorrect O₂ heater wiring.

Recommended actions

1. Check O₂ heater wiring per [Figure 9-2](#) and [Figure 10-8](#).
2. Check the wiring at the heater inside the electronics housing.
3. Correct wiring fault.
4. Perform procedure in [Reset](#) to continue operation.

Potential cause

Incorrect O₂ thermocouple wiring.

Recommended actions

1. Check O₂ thermocouple wiring per [Figure 9-2](#) and [Figure 10-8](#).
2. Check the wiring at the terminal and inside the electronics housing.
3. Correct wiring fault.
4. Perform procedure in [Reset](#) to continue operation.

Potential cause

Electronics package failure.

Recommended action

Replace electronics package.

9.3.7 COe Temp Very Hi or COe Htr Ramp Rate

Combustion sensor heater over maximum temperature, > 752 °F (400 °C). or combustibles sensor heater over maximum temperature ramp rate.

Potential cause

Incorrect COe heater wiring.

Recommended actions

1. Check COe heater wiring per [Figure 9-2](#) and [Figure 10-9](#).
2. Check the wiring at the heater and inside the electronics housing.
3. Correct wiring fault.
4. Perform procedure in [Reset](#) to continue operation.

Potential cause

Incorrect COe thermocouple wiring.

Recommended actions

1. Check COe thermocouple wiring per [Figure 9-2](#) and [Figure 10-9](#).
2. Check the wiring at the thermocouple and inside the electronics housing.
3. Correct wiring fault.

4. Perform procedure in [Reset](#) to continue operation.

Potential cause

Electronics package failure.

Recommended action

Replace electronics package.

9.3.8 SB Temp Very Hi or SB Htr Rmp Rate

Sample block heater over maximum temperature, > 500 °F (260 °C) or sample block heater over maximum temperature ramp rate.

Potential cause

Incorrect sample block heater wiring.

Recommended actions

1. Check sample block heater wiring per [Figure 9-2](#) and [Figure 10-8](#).
2. Check the wiring at the heater and inside the electronics housing.
3. Correct wiring fault.
4. Perform procedure in [Reset](#) to continue operation.

Potential cause

Incorrect sample block thermocouple wiring.

Recommended actions

1. Check sample block thermocouple wiring per [Figure 9-2](#) and [Figure 10-8](#).
2. Check the wiring at the thermocouple and inside the electronics housing.
3. Correct wiring fault.
4. Perform procedure in [Reset](#) to continue operation.

Potential cause

Electronics package failure.

Recommended action

Replace electronics package.

9.3.9 O₂ TC Open

Oxygen sensor heater thermocouple open.

Potential cause

O₂ thermocouple or thermocouple circuit open.

Recommended actions

1. Check O₂ thermocouple and circuit wires for breaks or loose connections per [Figure 9-2](#) and [Figure 10-8](#).
2. Repair breaks or loose connections or replace failed thermocouple.
3. Perform procedure in [Reset](#) to continue operation.

9.3.10 COe TC Open

Combustibles sensor heater thermocouple open.

Potential cause

Combustibles sensor thermocouple open.

Recommended actions

1. Check thermocouple resistance (lead to ground) of reference and active thermocouples per [Figure 9-2](#) and [Figure 10-10](#).
2. If either thermocouple is open or shorted to ground, replace combustibles sensor.

9.3.11 SB TC Open

Sample block heater thermocouple open.

Potential cause

Sample block heater thermocouple or thermocouple circuit open.

Recommended actions

1. Check sample block thermocouple and circuit wires for breaks or loose connections per [Figure 9-2](#) and [Figure 10-8](#).
2. Repair breaks or loose connections or replace failed thermocouple.
3. Perform [Reset](#) to continue operation.

9.3.12 O₂ TC Shorted

Oxygen sensor heater thermocouple shorted.

Potential cause

O₂ thermocouple or thermocouple circuit shorted.

Recommended actions

1. Check O₂ thermocouple and circuit wires for short circuit condition per [Figure 9-2](#) and [Figure 10-8](#).
2. Repair shorted wire or replace failed thermocouple.
3. Perform [Reset](#) to continue operation.

Potential cause

Slow heat up during cold start.

Recommended actions

1. Perform [Reset](#) to continue operation.
2. If alarm persists, refer to [O₂ Htr Failure](#).

9.3.13 COe TC Shorted

Combustibles sensor heater thermocouple shorted.

Potential cause

Combustibles sensor thermocouple shorted.

Recommended actions

1. Check thermocouple resistance (lead to ground) of reference and active thermocouples per [Figure 9-2](#) and [Figure 10-9](#).
2. If either thermocouple is open or shorted to ground, replace combustibles sensor.

Potential cause

Slow heat up during cold start.

Recommended actions

1. Perform [Reset](#) to continue operation.
2. If alarm persists, refer to [COe Htr Failure](#).

9.3.14 SB TC Shorted

Sample block heater thermocouple shorted.

Potential cause

Sample block thermocouple or thermocouple circuit shorted.

Recommended actions

1. Check sample block thermocouple and circuit wires for short circuit conditions per [Figure 9-2](#) and [Figure 10-8](#).
2. Perform [Reset](#).

Potential cause

Slow heat up during cold start.

Recommended actions

1. Perform [Reset](#) to continue operation.
2. If alarm persists, refer to [SB Htr Failure](#).

9.3.15 O₂ TC Reversed

Oxygen sensor heater thermocouple reversed.

Potential cause

O₂ thermocouple wires reversed.

Recommended actions

1. Check O₂ thermocouple wiring per [Figure 9-2](#) and [Figure 10-8](#).
2. Check the wiring at the sensor and inside the electronics housing.
3. Correct reversed-wires fault.
4. Perform [Reset](#) to continue operation.

9.3.16 COe TC Reversed

Combustibles sensor block heater thermocouple reversed.

Potential cause

Combustibles thermocouple wires reversed.

Recommended actions

1. Check thermocouple wiring per [Figure 9-2](#) and [Figure 10-9](#).
2. Check the wiring at the sensor and inside the electronics housing.
3. Correct reversed-wires fault.
4. Perform [Reset](#) to continue operation.

9.3.17 SB TC Reversed

Sample block heater thermocouple reversed.

Potential cause

Sample block thermocouple wires reversed.

Recommended actions

1. Check sample block thermocouple wiring per [Figure 9-2](#) and [Figure 10-8](#).
2. Check the wiring at the sensor and inside the electronics housing.
3. Correct reversed-wires fault.
4. Perform [Reset](#) to continue operation.

9.3.18 ADC Failure or ADC Ref Error

Voltage to digital conversion could not complete or voltage to digital version not accurate.

Potential cause

Incorrect wiring between electronics and sensor housings.

Recommended actions

1. Check all wiring between the electronics and sensor housings per [Figure 9-2](#).
2. Correct wiring faults.

Potential cause

Electronics package failure.

Recommended action

Replace electronics package.

9.3.19 O₂ Htr Failure

Oxygen sensor heater could not reach final temperature.

Potential cause

O₂ heater circuit wiring open.

Recommended actions

1. Check O₂ cell heater circuit for broken wire or loose connection per [Figure 9-2](#) and [Figure 10-8](#).
2. Repair broken wire or loose connection.

Potential cause

O₂ heater open.

Recommended actions

1. Check resistance of O₂ heater per [Figure 10-8](#).
Normal O₂ heater resistance is 62.5 Ohms.
2. Replace O₂ heater if heater is open or has a large resistance.

Potential cause

Heater electronics failure.

Recommended actions

Check heater fuse F3 in electronics housing per [Figure 9-1](#).

- If open, locate and correct cause of overload.
- If F3 is not open or if cause of overload cannot be found, replace electronics package.

9.3.20

COe Htr Failure

Combustibles sensor heater could not reach final temperature.

Potential cause

COe heater circuit wiring open.

Recommended actions

1. Check COe heater circuit for broken wire or loose connection per [Figure 9-2](#) and [Figure 10-9](#).
2. Repair broken wire or loose connection.

Potential cause

COe heater open.

Recommended actions

1. Check resistance of COe heater per [Figure 10-9](#).
Normal COe heater resistance is 97.7 Ohms.
2. Replace COe heater if heater is open or has a large resistance.

Potential cause

Heater electronics failure.

Recommended actions

Check heater fuse F3 in electronics housing per [Figure 9-1](#).

- If open, locate and correct cause of overload.
- If F3 is not open or if cause of overload cannot be found, replace electronics package.

9.3.21 SB Htr Failure

Sample block heater could not reach final temperature.

Potential cause

Sample block heater circuit wiring open.

Recommended actions

1. Check sample block heater circuit for broken wire or loose connections per [Figure 9-2](#) and [Figure 10-8](#).
2. Repair broken wire or loose connection.

Potential cause

Sample block heater open.

Recommended actions

1. Check resistance of sample block heater per [Figure 10-8](#).
Normal sample block heater resistance is 36.4 Ohms each (18.2 Ohms with both heaters in parallel).
2. Replace sample block heater if heater is open or has a large resistance.

Potential cause

Heater electronics failure.

Recommended actions

Check heater fuse F4 in electronics housing per [Figure 9-1](#).

- If open, locate and correct cause of overload.
- If F4 is not open or if cause of overload cannot be found, replace electronics package.

Potential cause

Sensor housing exposed to high wind and/or extreme cold temperatures.

Recommended action

If above causes are not causing the SB heater failure, install flange insulator (PN 6P00162H01).

9.3.22 Cal Warning or Cal Failed

Calibration warning or calibration failed.

Potential cause

Calibration gas supply low or gas connection leaking.

Recommended actions

1. Check calibration gas supplies and connections.
2. Adjust gas pressure and flow.
3. Replenish low calibration gas supplies and tighten or repair loose or leaking connections.
4. When calibration gas supplies are adequate, recalibrate.

Potential cause

O₂ cell degraded or failed.

O₂ slope error (Slope < 34.5 mV/Dec or > 57.2 mV/Dec).

Recommended actions

Check O₂ cell impedance by reading the O₂ Cell Imped value via the local operator interface (LOI) (see [Figure 4-4](#)) or the O₂ Snsr R value via the HART® menu tree (see [Figure 5-3](#)).

- If cell impedance is zero, replace the O₂ cell.
- If cell impedance is less than 5000 Ohms, check for cell housing ground fault. Repair ground fault.
- If cell impedance is greater than 5000 Ohms and no ground fault is indicated, replace O₂ cell.

Potential cause

O₂ constant error (constant not between -20 mV and +20 mV).

Recommended actions

1. Flow calibration gas to the O₂ cell.
2. Read the cell millivolt output.
3. Plot the cell millivolt output and the calibration gas O₂ concentration on the chart shown in [Figure 9-3](#).
4. If the plotted values do not fall on the slope line shown in [Figure 9-3](#), replace the O₂ cell.

Potential cause

COe sensor degraded.

COe slope error (slope not between 200 ppm/Ohm and 4,500 ppm/Ohm).

COe constant error (constant not between -100 Ohms and +100 Ohms).

Recommended action

Replace COe sensor or increase warning level (**SYSTEM**, **CALIB SETUP**, or **COe Slope Warn** via HART®).

Potential cause

Low sample gas flow in sensor housing due to flow path plugging.

Recommended action

Check the following portions of the flow path for plugging:

- Blowback filter
- In-situ filter
- Eductor outlet path

9.3.23 Board Temp Hi

Electronics temperature maximum exceeded, > 185 °F (85 °C).

Potential cause

Electronics housing exposed to high ambient temperature.

Recommended actions

1. Insulate housing from source of high temperature and/or install cooling fan to remove heat from housing.
2. Perform [Reset](#) to continue operation.

9.3.24 EEPRM Chksm Fail

Alert

Non-volatile parameter storage corrupted.

Potential cause

Transmitter powered down during calibration parameter storage.

Recommended actions

1. Perform [Reset](#).
2. Recalibrate the transmitter and check/trim analog outputs.

Potential cause

Flash PROM failure.

Recommended action

Replace electronics package.

9.3.25 O₂ Temp Low

Oxygen sensor heater temperature low, < 1310 °F (710 °C).

Potential cause

Sensor housing exposed to high wind and/or extreme cold temperatures.

Recommended action

Install sensor housing flange insulator (PN 6P00162H01).

Potential cause

High noise or voltage fluctuations in power supply.

Recommended action

1. Check power supply for line noise or voltage fluctuations.
2. Install filter power line kit (PN 6A00171G01) or high quality line filter for input power.

9.3.26 CO_e Temp Low

Combustion sensor heater temperature low, < 554 °F (290 °C).

Potential cause

Sensor housing exposed to high wind and/or extreme cold temperatures.

Recommended action

Install sensor housing flange insulator (PN 6P00162H01).

Potential cause

High noise or voltage fluctuations in power supply.

Recommended actions

1. Check power supply for line noise or voltage fluctuations.
2. Install filter power line kit (PN 6A00171G01) or high quality line filter for input power.

9.3.27 SB Temp Low

Sample block heater temperature low, < 302 °F (150 °C).

Potential cause

Sensor housing exposed to high wind and/or extreme cold temperatures.

Recommended action

Install sensor housing flange insulator (PN 6P00162H01).

Potential cause

High noise or voltage fluctuations in power supply.

Recommended actions

1. Check power supply for line noise or voltage fluctuations.
2. Install filter power line kit (PN 6A00171G01) or high quality line filter for input power.

9.3.28 Line Freq Error

AC power line frequency out of usable range, < 45 Hz or > 66 Hz.

Potential cause

High noise or voltage fluctuations in power supply.

Recommended actions

1. Check power supply for line noise or voltage fluctuations.
2. Install filter power line kit (PN 6A00171G01) or high quality line filter for input power.

Potential cause

AC power line frequency is outside the usable range of the Rosemount OCX8800 universal power supply.

Recommended action

Correct power supply frequency.
AC power line frequency must be between 50 and 60 Hz.

Potential cause

Electronics package failure.

Recommended action

1. Check power supply frequency with a calibrated oscilloscope or frequency meter and compare with line frequency.
2. Replace electronics package if they do not agree within 1 Hz.

9.3.29 Line Voltage Low

AC power line voltage below minimum, < 85 Vac.

Potential cause

High noise or voltage fluctuations in power supply.

Recommended actions

1. Check power supply for line noise or voltage fluctuations.
2. Install filter power line kit (PN 6A00171G01) or high quality line filter for input power.

Potential cause

Electronics package failure.

Recommended actions

1. Check power supply voltage and compare with line voltage.
2. Replace electronics package if they do not agree within five percent.

9.3.30 Line Voltage High

AC power line voltage above maximum, > 278 Vac.

Potential cause

High noise or voltage fluctuations in power supply.

Recommended actions

1. Check power supply for line noise or voltage fluctuations.
2. Install filter power line kit (PN 6A00171G01) or high quality line filter for input power.

Potential cause

Electronics package failure.

Recommended actions

1. Check power supply voltage and compare with line voltage.
2. Replace electronics package if they do not agree within five percent.

9.3.31 Htr Relay Failed

Heater relay failure.

Potential cause

High noise or voltage fluctuations in power supply.

Recommended actions

1. Check power supply for line noise or voltage fluctuations.
2. Install filter power line kit (PN 6A00171G01) or high quality line filter for input power.

Potential cause

Electronics package failure.

Recommended action

Replace electronics package.

9.3.32 Out Brd Failure

Output board failure

Potential cause

Electronics package failure.

Recommended action

Replace electronics package.

9.4 Alarm relay events

The transmitter contains an alarm relay that can be configured to activate on one of twelve different groups of events.

These event groups and the conditions that trigger them are listed in [Table 9-4](#).

Table 9-4: Alarm Relay Event Groups

Alarm relay event	Alarms/conditions
In calibration	Calibration in progress
O ₂ temperature error	Oxygen sensor heater temperature low (O₂ Temp Low) Oxygen sensor heater temperature high (O₂ Temp Hi , O₂ Temp Very Hi) Resistance temperature device (RTD) excitation current error (Ref Curr Err)
Heater failure	Oxygen sensor heater could not reach final temperature (O₂ Htr Failure) Combustibles sensor heater could not reach final temperature (COe Htr Failure) Sample block heater could not reach final temperature (SB Htr Failure)
O ₂ sensor error	Oxygen sensor resistance high (O₂ Sensor R High) Oxygen sensor disconnected (O₂ Sensor Open)
Calibration failure	Calibration failed (Cal Failed)
Calibration warning	Calibration warning (Cal Warning)
Board temperature high	Electronics temperature maximum exceeded (Board Temp Hi)

Table 9-4: Alarm Relay Event Groups (continued)

Alarm relay event	Alarms/conditions
Unit failure	Any non-recoverable or heater relay off alarm (O₂ Temp Hi, O₂ Temp Very Hi, COe Temp Hi, COe Temp Very Hi, SB Temp Hi, SB Temp Very Hi, O₂ Htr Ramp Rate, COe Htr Ramp Rate, SB Heater Ramp Rate, O₂ TC Shorted, O₂ TC Reversed, COe TC Shorted, COe TC Reversed, SB TC Shorted, SB TC Reversed, ADC Failure, ADC Ref Error, Board Temp Hi, EEPRM Chksm Fail, Line Freq Error, Line Voltage Low, Line Voltage Hi, Htr Relay Failed, Out Brd Fail)
Sample block temperature error	Sample block heater temperature low (SB Temp Low) Sample block heater temperature high (SB Temp Hi, SB Temp Very Hi) RTD excitation current error (Ref Curr Err)
COe sensor temperature error	Combustibles sensor heater temperature low (COe Temp Low) Combustibles sensor heater temperature high (COe Temp Hi, COe Temp Very Hi) RTD excitation current error (Ref curr Err)
Power input error	AC power line frequency out of usable range (Line Freq Error) AC power line voltage below minimum (Line Voltage Low) AC power line voltage above maximum (Line Voltage Hi)
All alarms	Any alarm

10 Maintenance and service

10.1 Overview

This section contains the procedures to maintain and service the transmitter.

⚠ WARNING

Electric shock

Failure to install covers and ground leads could result in serious injury or death.

Install all protective equipment covers and safety ground leads after equipment repair or service.

⚠ WARNING

Burns

Failure to comply may cause severe burns.

Remove the transmitter from the stack for all service activities. Allow the transmitter to cool and take it to a clean work area.

⚠ WARNING

Electric shock

There may be voltage up to 264 Vac.

Disconnect and lock out power before working on any electrical components.

⚠ WARNING

Housing classifications

Failure to observe classification guidelines may result in serious injury or death.

Observe housing classification guidelines prior to removing cover.

10.2 Removal and installation

10.2.1 Rosemount OCX8800 with integral electronics

Remove transmitter

Procedure

1. Turn off power to the system.
2. Shut off the test gases at the cylinders and shut off the instrument air.
3. Disconnect the test gas and instrument air lines from the electronics housing as shown in [Figure 10-1](#).

Figure 10-1: Rosemount OCX8800 with Integral Electronics

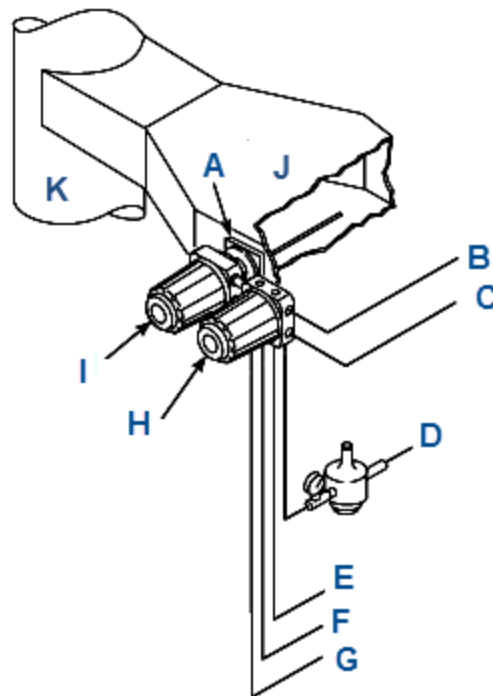

- A. Adapter plate
- B. Signal outputs (twisted pairs)
- C. AC power input
- D. Instrument air (reference gas)
- E. High O₂ test gas
- F. Low O₂ test gas
- G. CO test gas
- H. Electronics housing
- I. Sensor housing
- J. Duct
- K. Stack

⚠ WARNING

Explosion hazard!

Failure to allow adequate time for all internal electrical charges to dissipate can result in serious injury or death.

Before removing the cover from the sensor or electronics housing, allow at least 45 minutes to pass after disconnecting power.

4. Remove the cover from the electronics housing to expose the electronics housing and terminal blocks, [Figure 10-2](#).

Figure 10-2: Electronics Housing Terminal Blocks

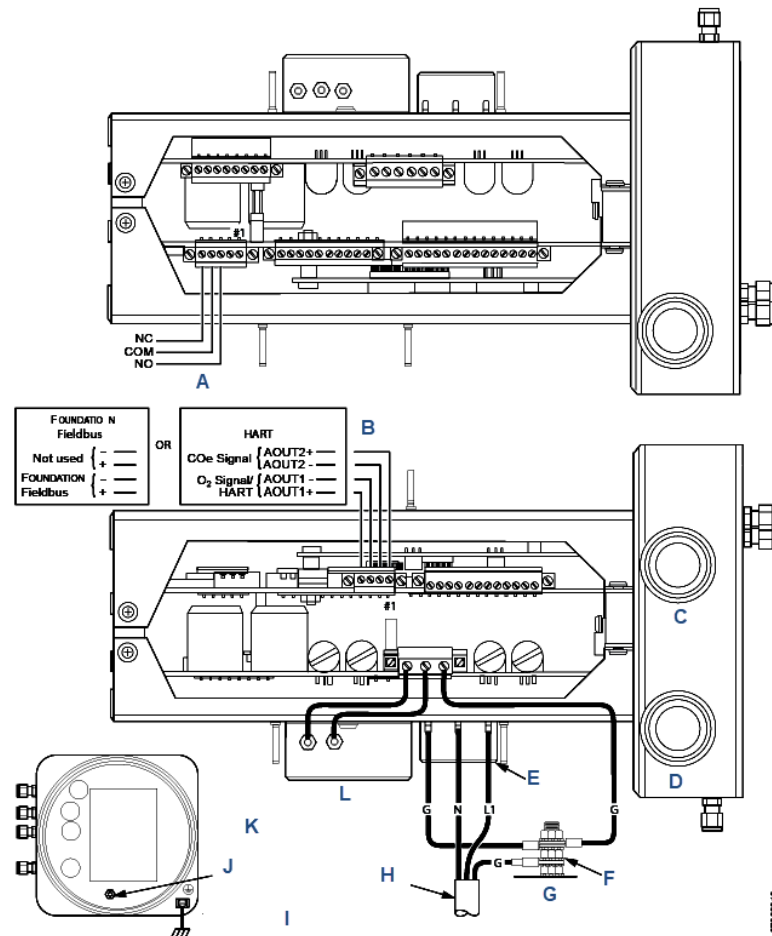

- A. Alarm output relay terminal block
- B. Signal output terminal block
- C. Signal port $\frac{3}{4}$ national pipe thread (NPT)
- D. Power port $\frac{3}{4}$ NPT
- E. Terminal block
- F. External tooth lockwasher
- G. Ground stud
- H. Customer wiring
- I. Earth ground typical for electronics and sensor housing
- J. Ground stud
- K. Top view ($\frac{1}{2}$ size)

5. Disconnect and remove the power leads from the AC power input terminal block and remove the ground lead from the ground stud.
6. Disconnect and remove the O₂ and CO_e signal leads from the 4-20 mA signal output terminal block.
7. If used, disconnect and remove the external relay leads from the alarm output relay terminal block.

8. Disconnect and remove customer power and signal wire conduits and wiring from the electronics housing.
9. Remove insulation to access the sensor housing mounting bolts. Unbolt the transmitter from the stack and take it to a clean work area.
10. Allow the transmitter to cool to a comfortable working temperature.

Install transmitter

Observe the following cautions when installing the transmitter in a hot process stack. If you shut down and cool the transmitter, you can install it in the stack prior to connecting the pneumatics and wiring.

⚠ CAUTION

Equipment damage

Exposing a cold transmitter to hot process gases can cause permanent damage to the equipment.

Before installing the transmitter into a hot stack or ductwork, make sure it is turned on and at a normal operating temperature.

⚠ CAUTION

Equipment damage

Failure to connect the pneumatic lines can allow the flow of contaminants into the transmitter ports.

Whenever a positive stack pressure exists at the installation site, be sure to connect all pneumatic lines prior to installing the transmitter in the stack or ductwork.

Procedure

1. Connect the test gas lines and instrument air lines to the electronics housing.
2. Remove the electronics housing cover.
3. Install customer power and signal conduits and wiring at the electronics housing.
4. If used, connect external relay leads to the alarm output relay terminal block, [Figure 10-2](#).
5. Connect the O₂ and COe signal leads to the 4-20 mA signal output terminal block.
6. Connect the line (L1 wire) to the L1 terminal and the neutral (N wire) to the N terminal on the AC power input terminal block.
7. Connect the ground lead to the ground stud. Secure the connection with two nuts. Attach a separate ground lead (G wire) from the ground stud to the G terminal on the power input terminal block.
8. Install the cover on the electronics housing.
9. Restore power to the system. Allow the transmitter to reach normal operating temperature before installing it in a hot process stack.
10. Bolt the transmitter to the stack and install insulation.
Refer to [Figure 10-2](#) and make sure all test gas lines and electrical connections are complete.
11. Turn on the test gases at the cylinders and open the instrument air supply valve.

10.2.2 Rosemount OCX8800 with remote electronics

Remove sensor housing

Procedure

1. Turn off power to the system.
2. Shut off the test gases at the cylinders and close the instrument air valve.
3. Disconnect the calibration gas, reference air, eductor air, and dilution air lines from the sensor housing, [Figure 10-3](#).

Figure 10-3: Transmitter with Remote Electronics

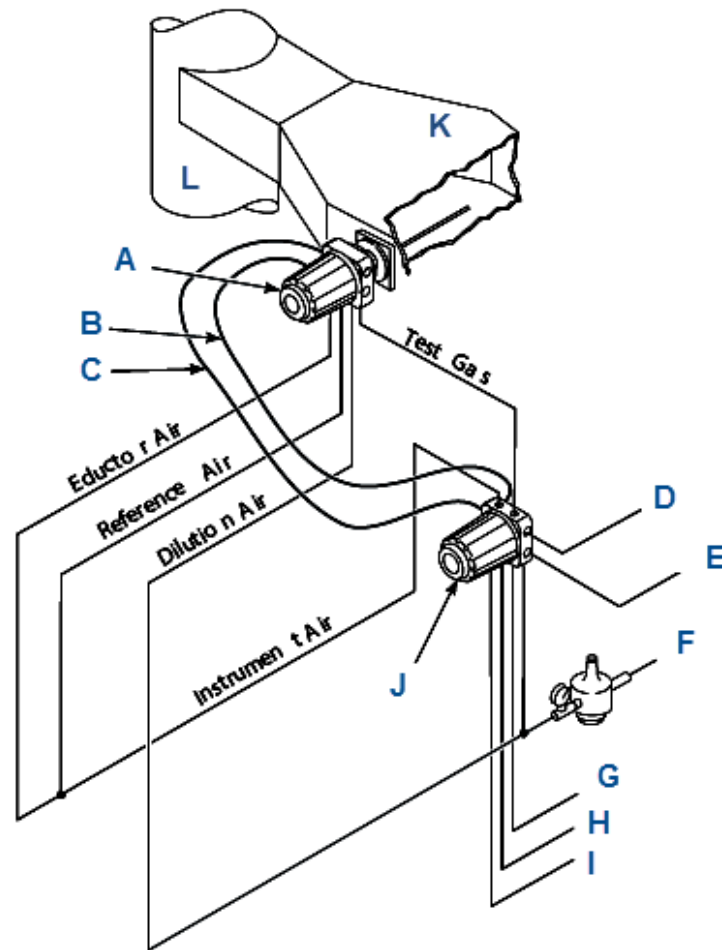

37390044

- A. Sensor housing
- B. Heater power cable
- C. Signal cable
- D. Signal outputs
- E. AC power input
- F. Instrument air (reference gas)
- G. High O₂ test gas
- H. Low O₂ test gas
- I. CO test gas
- J. Electronics housing
- K. Duct
- L. Stack

4. Remove the cover from the sensor housing to expose the sensor housing terminal blocks, [Figure 10-4](#).

Figure 10-4: Sensor Housing Terminals

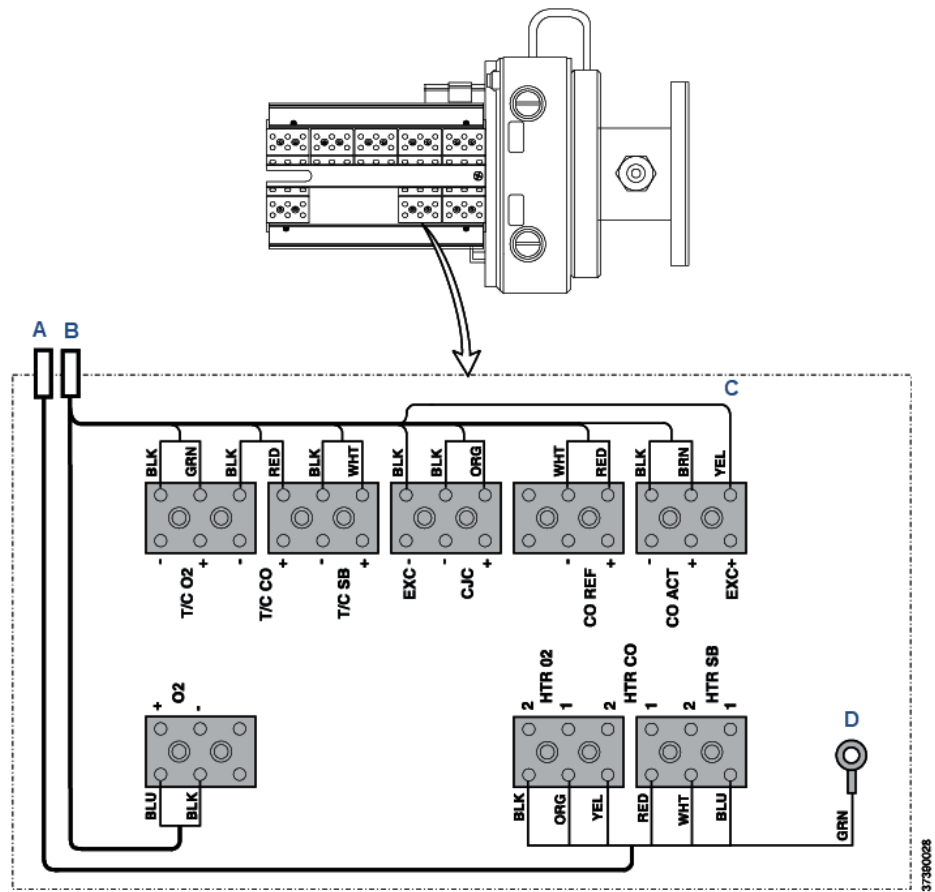

- A. Heater power cable
- B. Signal cable
- C. Sensor housing
- D. To ground screw

Note

Wire colors shown are for cables provided by Emerson.

Table 10-1: Sensor Housing Terminal Connections

Wire color	Connects to
Black	Thermocouple (T/C) O ₂ -
Green	T/C O ₂ +
Black	T/C CO-
Red	T/C CO+
Black	T/C sample block (SB)-
White	T/C SB+
Black	CJC-

Table 10-1: Sensor Housing Terminal Connections (continued)

Wire color	Connects to
Orange	CJC+
White	CO reference-
Red	CO reference+
Black	CO act-
Brown	CO act+
Yellow	Exc+
Blue	O ₂ +
Black	O ₂ -
Black	Heater O ₂ 2
Orange	Heater O ₂ 1
Yellow	Heater CO 2
Red	Heater CO 1
White	Heater SB 2
Blue	Heater SB 1
Green	Ground screw

5. Disconnect the signal cable from the O₂ and T/C terminal blocks and from the CO and CJC terminal blocks.
6. Disconnect the heater power cable from the heater terminal blocks.
7. If moving the sensor housing to another work site, disconnect and remove the power and signal cables from the sensor housing.
8. Remove insulation to access the mounting bolts. Unbolt the sensor housing from the stack and take it to a clean work area.
9. Allow the sensor housing to cool to a comfortable working temperature.

Install sensor housing

Procedure

1. Connect the test gas, reference air, eductor air, and dilution air lines to the sensor housing.
2. Remove the sensor housing cover.
3. If removed, install the power and signal cables and the customer power and signal conduits and wiring at the sensor housing.
4. Connect the signal cable to O₂ and thermocouple (T/C) terminal blocks and to the CO and CJC terminal blocks, [Figure 10-4](#). Connect the heater power cable to the HTR terminal blocks.
5. Refer to [Figure 10-3](#) and make sure all test gas lines and electrical connectors are complete.
6. Install the sensor housing cover.
7. Restore power to the system. Allow the transmitter to reach normal operating temperature.
8. Insert and bolt the sensor housing in the stack and install insulation.

9. Turn on the test gases at the cylinders and open the instrument air supply valve.

Remove remote electronics housing

Procedure

1. Turn off power to the system.
2. Shut off the test gases at the cylinders and close the instrument air supply valve, [Figure 10-3](#).
3. Disconnect the test gas and instrument air lines from the remote electronics housing.
4. Remove the cover from the electronics housing to expose the electronics housing terminal blocks, [Figure 10-5](#).

Figure 10-5: Electronics housing terminal blocks

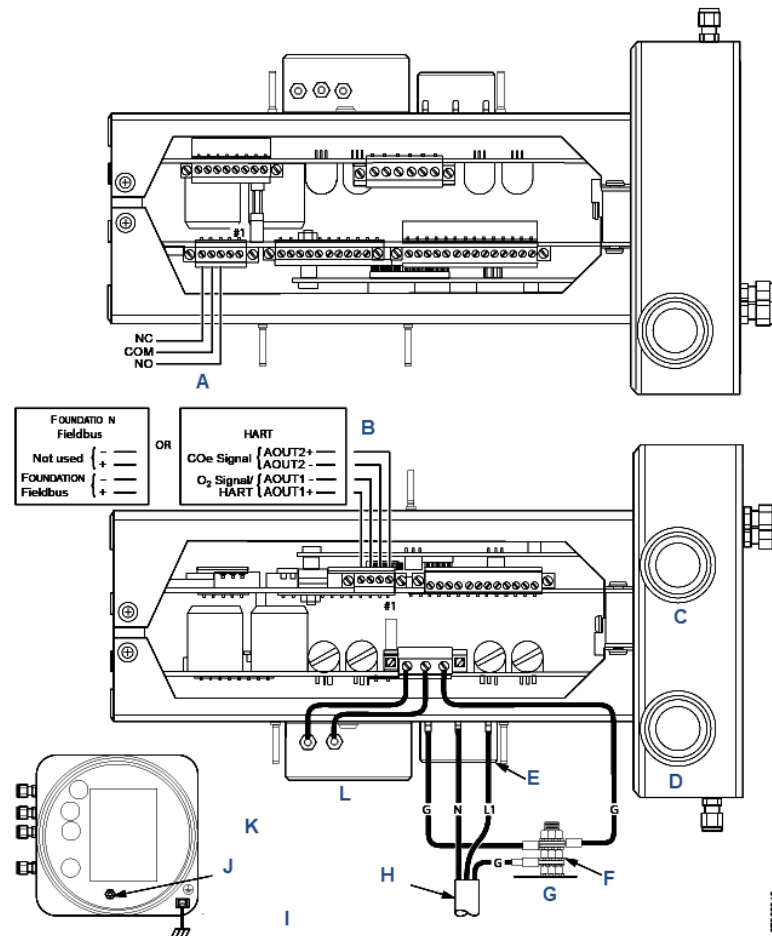

- A. Alarm output relay
- B. 4-20 mA signal output terminal block
- C. Signal port $\frac{3}{4}$ national pipe thread (NPT)
- D. Power port $\frac{3}{4}$ NPT
- E. Terminal block
- F. External tooth lockwasher
- G. Ground stud
- H. Customer wiring
- I. Earth ground typical for electronics and sensor housing
- J. Ground stud
- K. Top view ($\frac{1}{2}$ size)
- L. EMI filter

5. Disconnect and remove the power leads from the AC power input terminal block. Remove the ground lead from the ground stud.
6. Disconnect and remove the O₂ and CO_e signal leads from the alarm output relay terminal block.

7. If used, disconnect and remove the external relay leads from the alarm output relay terminal block.
8. Disconnect the signal cable leads from the O₂ cell and thermocouple connector (J4) and from the COe and CJC connector (J5), **Figure 10-6**.

Figure 10-6: Remote Electronics Housing Cable Connections

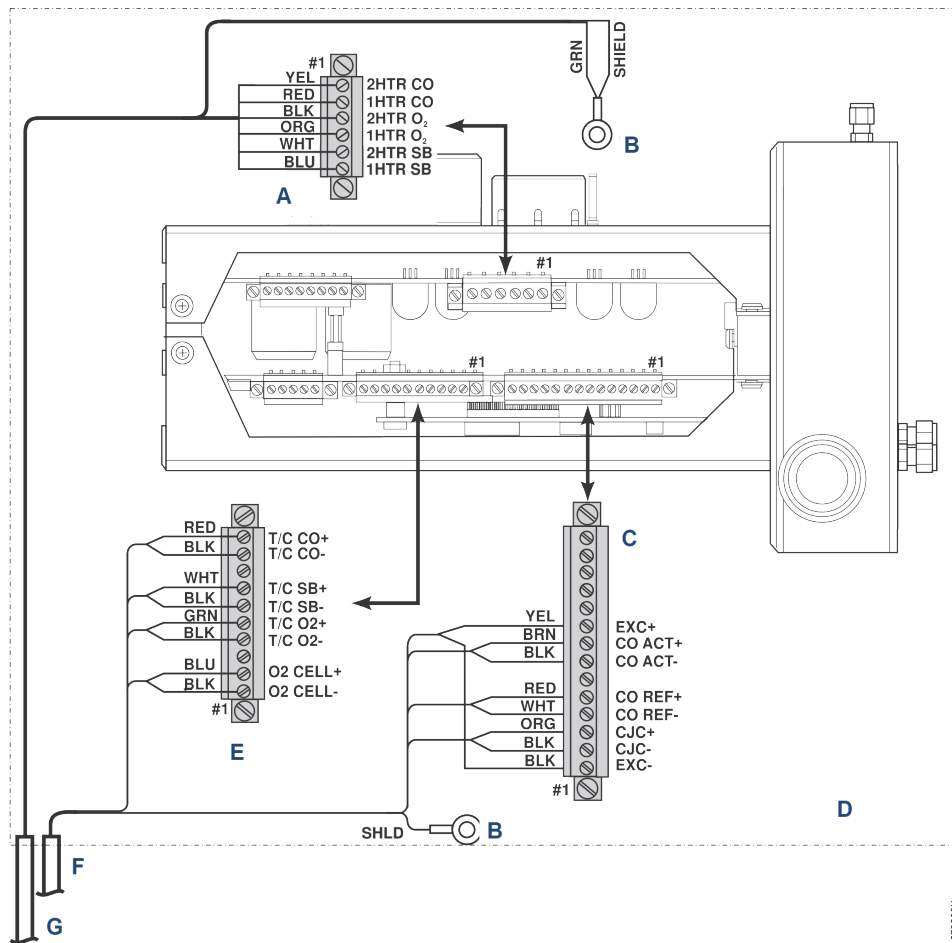

- A. Heater power connector (J3)
- B. To ground screw
- C. COe sensor and CJC connector (J4)
- D. Electronics housing
- E. O₂ cell and thermocouple connector (J5)
- F. Signal cable
- G. Heater power cable

Note

Wire colors shown are for cables supplied by Emerson.

Table 10-2: J3 Connections

Wire color	Connects to
Yellow	2 heater CO

Table 10-2: J3 Connections (continued)

Wire color	Connects to
Red	1 heater CO
Black	2 heater O ₂
Orange	1 heater O ₂
White	2 heater sample block (SB)
Blue	1 heater SB

Table 10-3: J4 Connections

Wire color	Connects to
Yellow	Exc+
Brown	CO act+
Black	CO act-
Red	CO reference+
White	CO reference-
Orange	CJC+
Black	CJC-
Black	Exc-

Table 10-4: J5 Connections

Wire color	Connects to
Red	Thermocouple (T/C) CO+
Black	T/C CO-
White	T/C SB+
Black	T/C SB-
Green	T/C O ₂ +
Black	T/C O ₂ -
Blue	O ₂ cell+
Black	O ₂ cell-

9. Disconnect the heater cable leads from the heater power connector (J3).
10. If moving the electronics housing to another work site, disconnect and remove the power and signal cables and customer wiring conduits from the housing.
11. Remove the remote electronics housing from its mounting and move it to a suitable work area.

Install remote electronics housing

Procedure

1. Mount remote electronics housing on wall or pipe within distance of signal and heater cables in use.
2. Remove the electronics housing cover.
3. If removed, install the power and signal cables and the customer power and signal conduits and wiring at the electronics housing.
4. Connect the signal cable leads to the O₂ cell and thermocouple connector (J4) and to the COe and CJC connector (J5), [Figure 10-6](#).
5. Connect the heater cable leads to the heater power connector (J3).
6. Connect the ground lead to the ground stud. Secure the connection with two nuts. Attach a separate ground lead (G wire) from the ground stud to the G terminal on the power input terminal block.
7. If used, connect external relay leads to the alarm output relay terminal.
8. Connect the test gas and instrument air lines to the remote electronics housing. Connect the calibration gas line and instrument air line to the remote electronics housing.
9. Refer to [Figure 10-3](#) and [Figure 10-6](#). Make sure all test gas lines and electrical connections are complete.
10. Install the cover on the electronics housing.
11. Turn on the test gases at the cylinders and open the instrument air valve.
12. Restore power to the system.

10.3 Repair sensor housing

Use the following procedures to remove damaged components from the transmitter's sensor housing and to install new replacement parts.

Disassemble the transmitter only as needed to replace damaged components. Use the applicable assembly procedures to install replacement parts and reassemble the transmitter.

10.3.1 Disassemble sensor housing

Remove cover and terminals insulator

Figure 10-7: Removal of O₂ Cell and Heater Strut Assembly

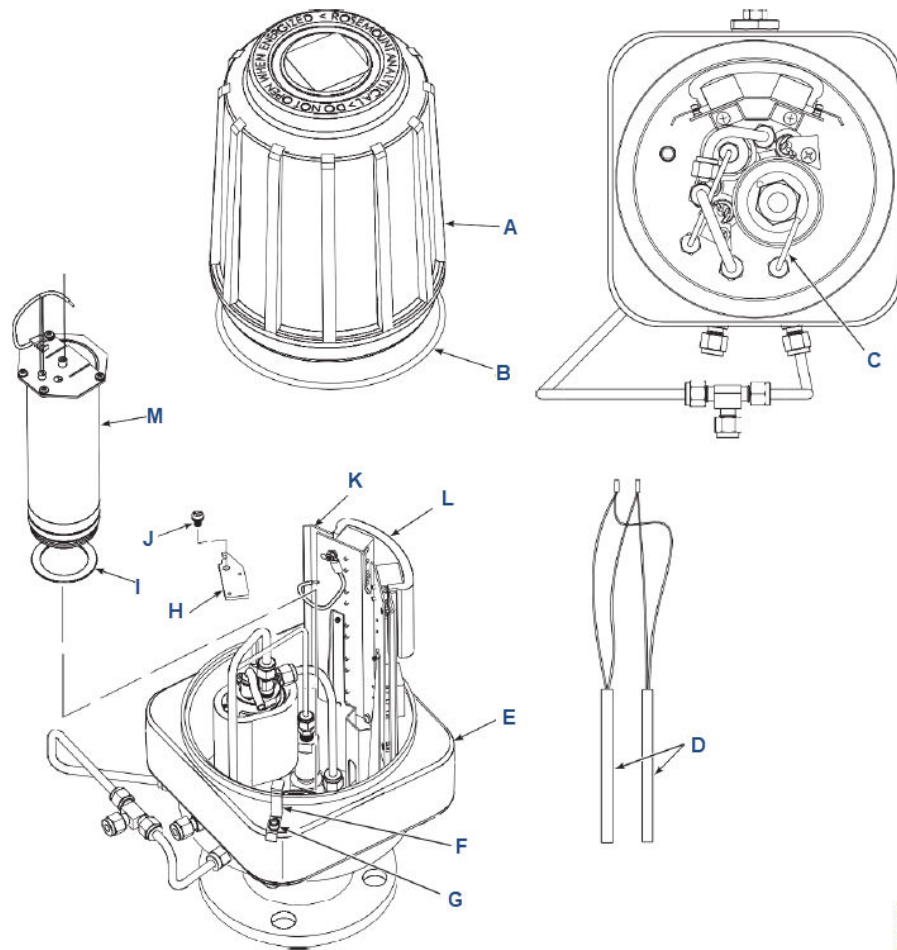

- A. Cover
- B. O-ring
- C. Reference air tube
- D. Heater rod
- E. Sensor housing
- F. Locking clip
- G. Screw
- H. Heater clamp
- I. Gasket
- J. Screw
- K. Marking plate
- L. Terminal insulator
- M. Heater strut assembly

Procedure

1. Loosen screw and slide locking clip away from cover. Retighten screw.
2. With two hands or a strap wrench, turn the cover counterclockwise to loosen. Unthread and remove the cover.

3. Inspect the cover O-ring for wear or damage. Replace the cover O-ring if damaged.
4. Unsnap terminal marking plates and remove terminal insulator.

Remove O₂ cell and heater strut assembly

Refer to [Figure 10-8](#).

Procedure

1. Remove reference air tube from sensor housing.
2. See [Figure 10-8](#). Disconnect and tag O₂ heater wires, O₂ cell and return wires, and thermocouple wires at the sensor housing terminals.

Figure 10-8: O₂ Cell, Thermocouple, and Heater Connections

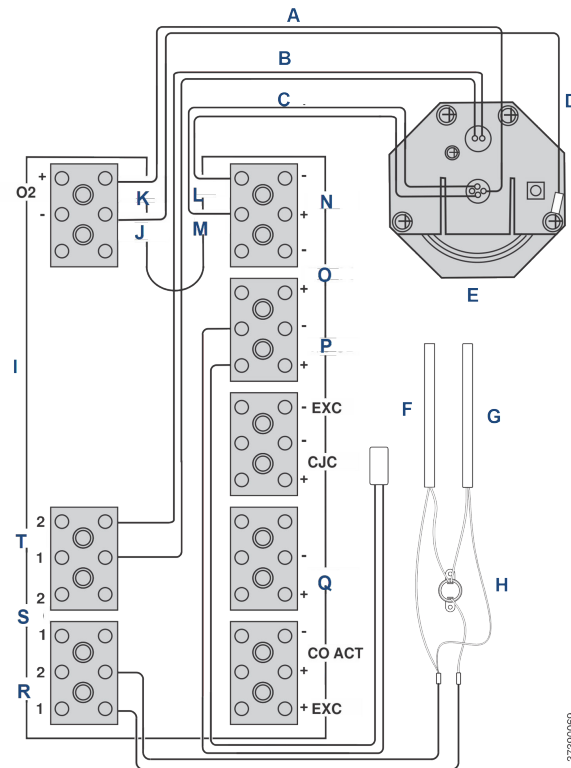

- A. O₂ cell wires
- B. O₂ heater wires
- C. Thermocouple wires
- D. Return wire
- E. O₂ cell and heater strut assembly
- F. Sample block thermocouple
- G. Sample block heater rods
- H. Thermal switch
- I. Sensor housing terminals
- J. Green
- K. Orange
- L. Red
- M. Yellow
- N. Thermocouple O₂
- O. Thermocouple CO
- P. Thermocouple sample block
- Q. CO reference
- R. Heater sample block
- S. Heater CO
- T. Heater O₂

3. Remove the O₂ cell and heater strut assembly from sensor housing. Remove and discard gasket.

Remove sample block heater rods

Procedure

1. Disconnect sample block heater rod wires from terminal block.
Refer to [Figure 10-8](#).
2. Loosen screws and rotate heater clamps to release heater rods.
One heater clamp secures each heater rod.
3. Slide sample block heater rods out of housing.

Remove COe sensor assembly

Procedure

1. Disconnect the COe heater, thermocouple, and sensor wires from the terminal blocks.
Refer to [Figure 10-9](#).

Figure 10-9: COe Sensor, Thermocouple, and Heater Connections

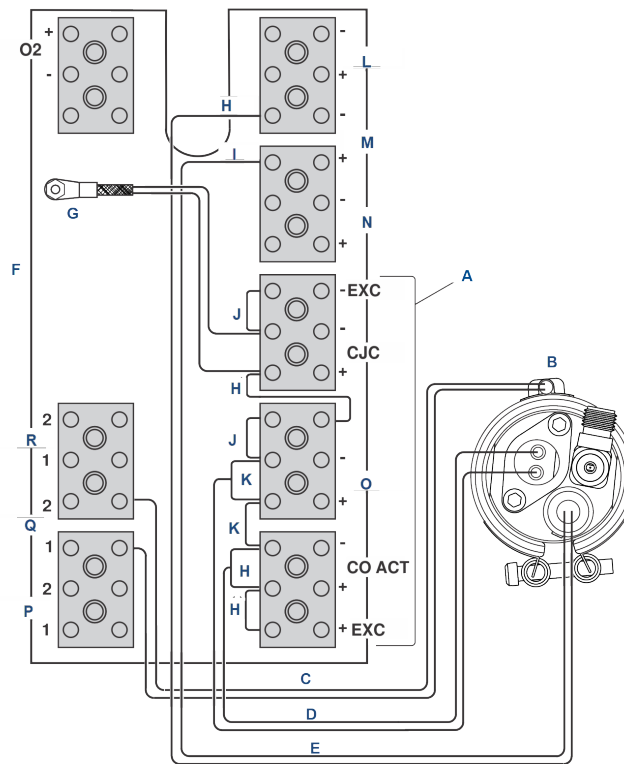

A. Note

All wires at these terminals are in the CJC current loop.

- B. COe sensor assembly
- C. COe heater wires
- D. COe sensor wires
- E. COe thermocouple wires
- F. Sensor housing terminals
- G. CJC sensor
- H. Red
- I. Yellow
- J. Blue
- K. White
- L. Thermocouple O₂
- M. Thermocouple CO
- N. Thermocouple sample block
- O. CO reference
- P. Heater sample block
- Q. Heater CO
- R. Heater O₂

2. Remove insulator (A, [Figure 10-10](#)).

Figure 10-10: Removal of COe Sensor Assembly

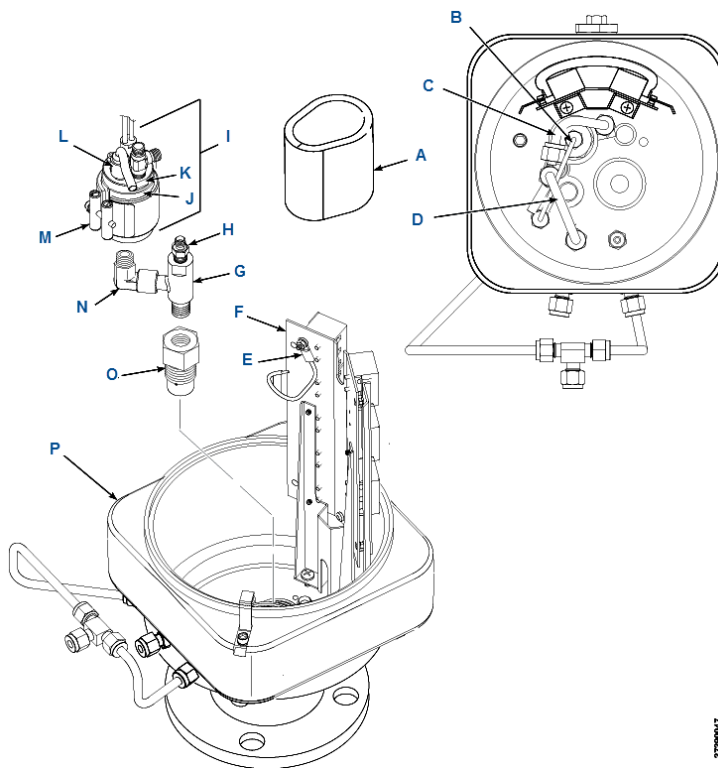

- A. Insulator
- B. Eductor air tube
- C. COe extractive tube
- D. Dilution air tube
- E. CJC sensor
- F. Terminal block mounting
- G. Eductor
- H. Tube fitting
- I. COe sensor assembly
- J. Sensor holder
- K. Heater insulator
- L. COe thermocouple
- M. COe band heater
- N. Eductor elbow
- O. Eductor holder
- P. Sensor housing

Note

For easier access, you may remove two screws from the base of the terminal block mounting (F) and move the terminal block mounting assembly out of the way.

3. Remove tubes (B, C, and D) from the COe sensor assembly (I), eductor fittings (N and H), and sensor housing (P).
4. Unfasten bayonet connector of COe thermocouple (L) and remove thermocouple.

5. Loosen clamp screw of COe band heater (M) until the heater rotates freely on the sensor holder.
6. See [Figure 10-11](#). Using a straight edge on the sensor holder flat, as shown, matchmark the upper flange of sensor housing to show the correct alignment of the sensor holder (J).

Figure 10-11: Alignment of COe Sensor Assembly

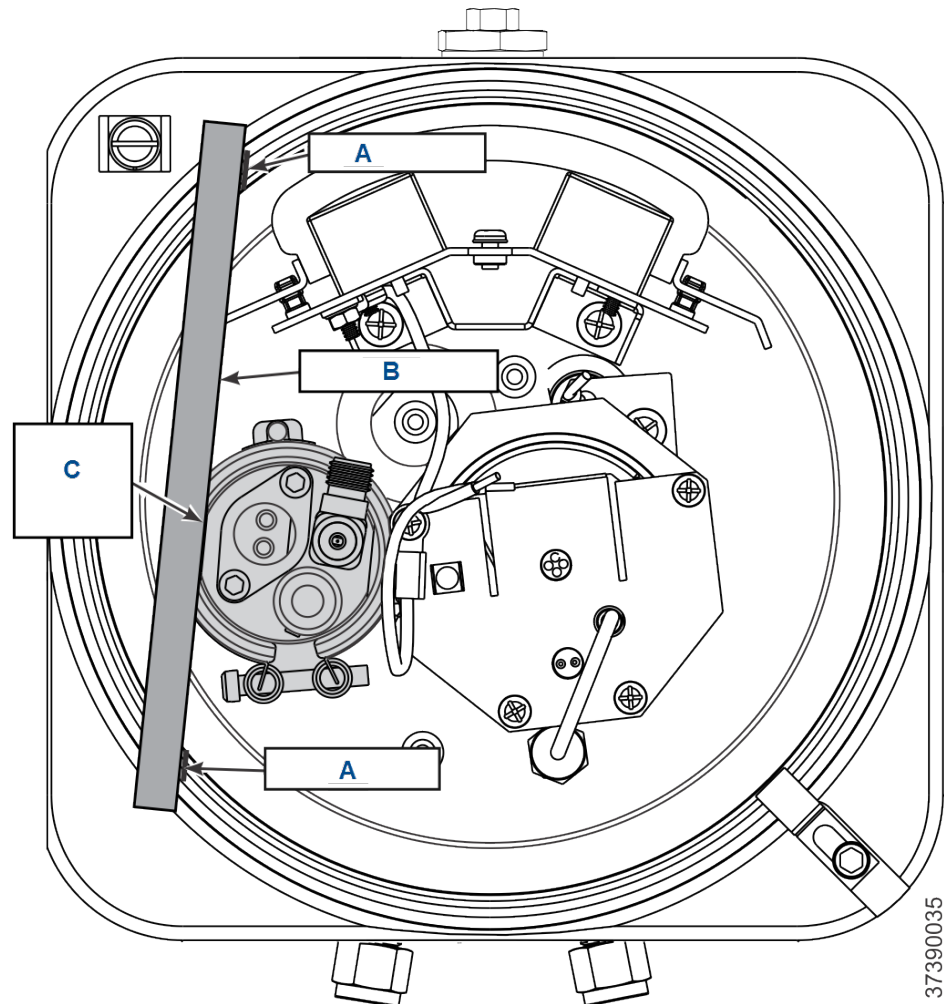

- A. Matchmark
- B. Straightedge
- C. Sensor holder flat

7. With one wrench holding the eductor elbow (N, [Figure 10-10](#)) and one wrench on flats of sensor holder (J), unthread and remove the COe sensor assembly (I). Do not allow the eductor elbow to turn.
8. Slide the band heater (M) and heater insulator (K) from the sensor holder (J).

Remove eductor

Prerequisites

Remove the O₂ cell and heater strut assembly (Figure 10-8) and the COe assembly (Figure 10-10) before you start this procedure.

Procedure

1. Use a straightedge to matchmark alignment of the eductor flat and elbow, as shown in Figure 10-12.

Figure 10-12: Eductor Alignment Matchmarks

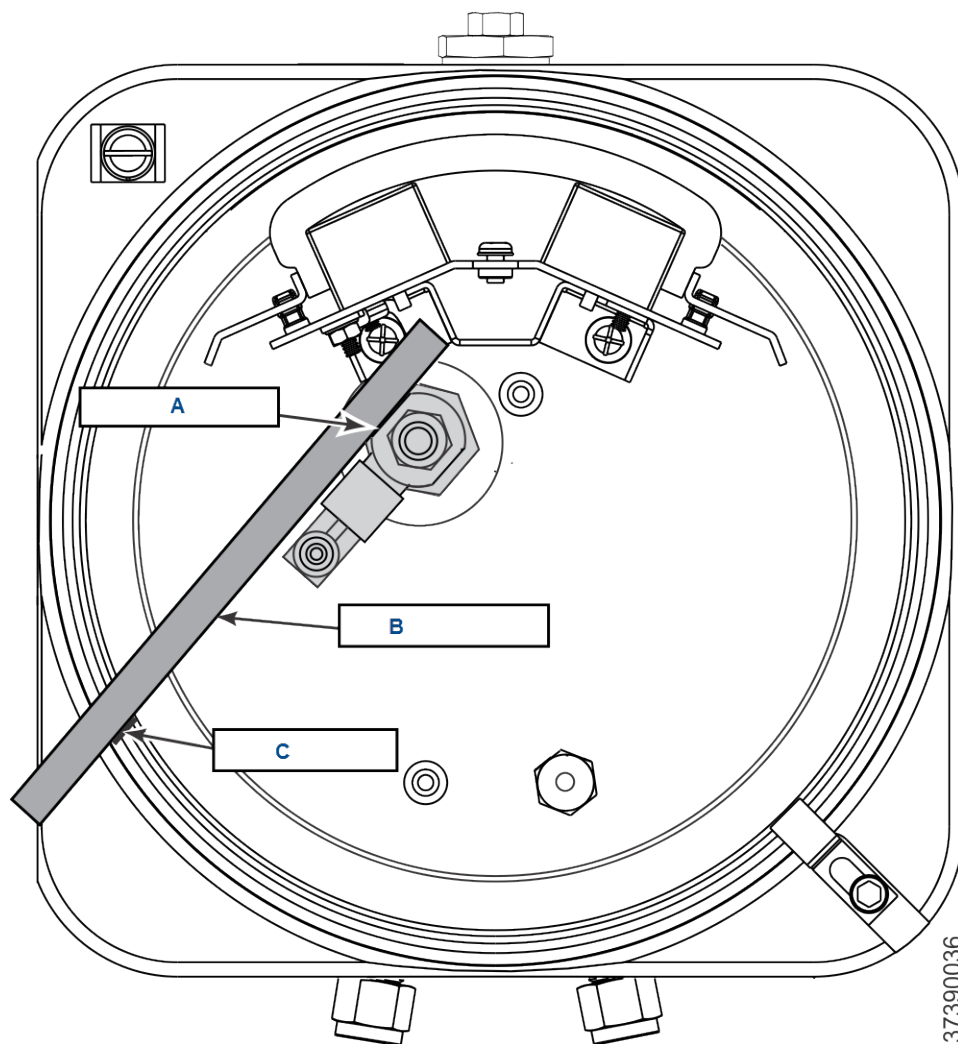

37390036

- A. Eductor flat
- B. Straight edge
- C. Matchmark

2. Unscrew the terminal block mounting (Figure 10-10). Move the terminal block mounting away from the eductor.
3. Unscrew the eductor holder with eductor and fittings from the sensor housing.

4. Clamp the flats of the eductor in the jaws of the bench vise.

⚠ WARNING

Burns

The mating parts are bonded with a thread sealing compound. The compound softens at 450 °F (232 °C). The heated parts can cause severe burns.

Use heat resistant gloves when removing mating parts from the eductor.

5. Use a propane torch to heat the eductor to 450 °F (232 °C) minimum. Apply the heat near the screw threads.
6. While heating the eductor, use a wrench to apply removal torque to the elbow, eductor holder, or tube fitting until the thread sealant softens. Remove the mating parts.
7. Use MEK or methylene chloride solvent to clean thread sealant residue from the pipe threads of the mating parts.
Refer to the applicable material safety data sheet (MSDS) for solvent handling precautions.

Remove sample and exhaust tubes

⚠ WARNING

Burns

The tubes are bonded with a thread sealing compound. The compound softens at 450 °F (232 °C). The heated parts can cause severe burns.

Use heat resistant gloves when removing the probe or exhaust tube.

Figure 10-13: Removal of Sample and Exhaust Tubes

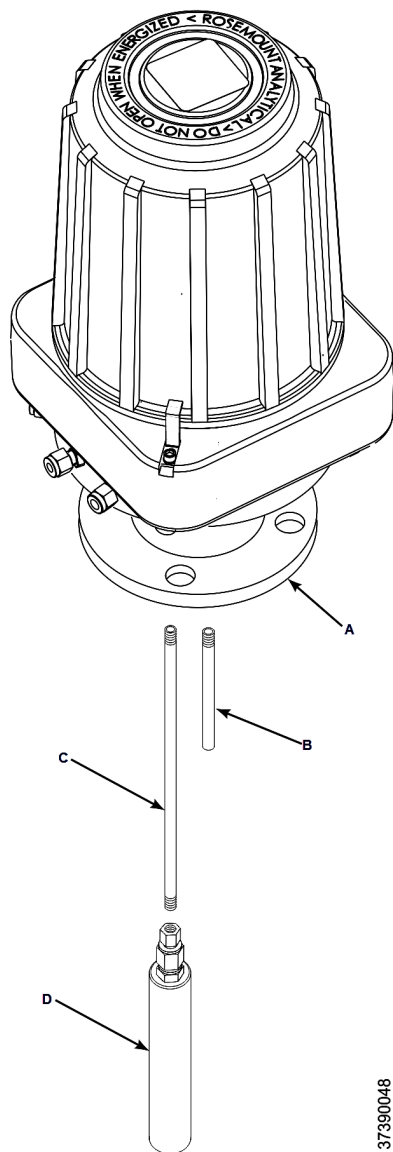

- A. Sensor housing
- B. Exhaust tube
- C. Sample tube
- D. In-situ filter

Procedure

1. Secure the sensor housing (A, Figure 10-13) in soft (plastic, wood, or brass) vice jaws.
2. Use a propane torch to heat the sample tube (C) or exhaust tube (B) to 450 °F (232 °C) minimum. Apply the heat near the threaded end of the tube.
3. While heating the tube, use a pipe wrench to apply removal torque to the part being removed. Apply torque until the pipe thread sealant softens. Remove and discard the used sample tube (C), exhaust tube (B), or in-situ filter (D).

4. Use MEK or methylene chloride solvent to clean thread sealant residue from the internal pipe threads in the housing.
Refer to the applicable material safety data sheet (MSDS) for solvent handling precautions.

Diassemble O₂ cell and heater strut assembly

⚠ CAUTION

Equipment damage

Removing the O₂ cell may damage the cell and platinum pad.

Do not remove the O₂ cell unless you are certain it needs to be replaced.

Figure 10-14: O₂ Cell, Heater, and Thermocouple Assembly, Exploded View

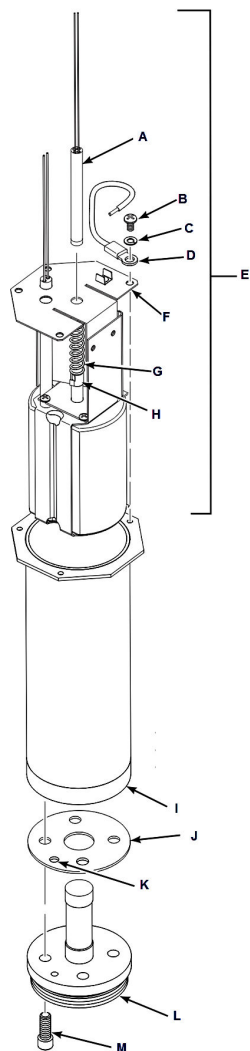

- A. Contact/thermocouple assembly
- B. Screw
- C. Lockwasher
- D. Return wire
- E. Heater strut assembly
- F. Strut bracket
- G. Spring
- H. Spring clip
- I. Heater tube
- J. Gasket
- K. Test gas passage holes
- L. O₂ cell
- M. Screw

Do not attempt to replace the O₂ cell until all other possibilities for poor performance have been considered. If cell replacement is needed, order the O₂ cell replacement kit (refer to [Replacement parts](#)).

The O₂ cell replacement cell contains an O₂ cell and flange assembly, gaskets, socket head cap, screws, and anti-seize compound. The items are carefully packaged to preserve precise surface finishes.

Do not remove items from the package until you are ready to use them.

Procedure

1. Remove the four Allen cap screws (M, [Figure 10-14](#)) from the O₂ cell (L). Remove the O₂ cell.

The cell flange has a notch that may be used to gently pry the flange away from the heater tube (I).

Note

The pad on the end of the contact/thermocouple assembly (A) will sometimes fuse to the O₂ cell (L).

2. If the O₂ cell is fused to the contact pad, push the O₂ cell back into the heater tube (against spring pressure) and quickly twist the O₂ cell.

The cell and contact pad should separate. If the contact pad stays fused to the cell, you will need to install a new contact/thermocouple assembly (A).

3. Remove and discard the gasket (J). Clean the mating surface of the heater tube (I). Remove burrs and raised surfaces with a block of wood and a crocus cloth.

⚠ CAUTION

Equipment damage

The ceramic rod in this assembly is fragile.

Use care when handling the contact and thermocouple assembly.

4. Remove screws (B), lockwashers (C), return wire (D), and heater strut assembly (E).
5. If replacing contact and thermocouple assembly (A), use a pencil to mark the location of the spring clip (H) before removing. Squeeze tabs on the spring clip to remove. Retain the spring clip and spring (G); replace if damaged.
6. While carefully handling the new contact and thermocouple assembly (A), lay the old assembly next to the new one. Transfer match marks to the new assembly.
7. Carefully guide the new contact and thermocouple assembly (A) through the strut bracket (F), spring (G), and spring clip (H) until the spring clip reaches the pencil mark.

Disassemble COe sensor assembly

Procedure

1. Carefully remove screws (I, [Figure 10-15](#)), lockwashers (H), and COe sensor (A) from the sensor holder (E). Remove and discard the gasket (F).

Figure 10-15: COe Sensor, Exploded View

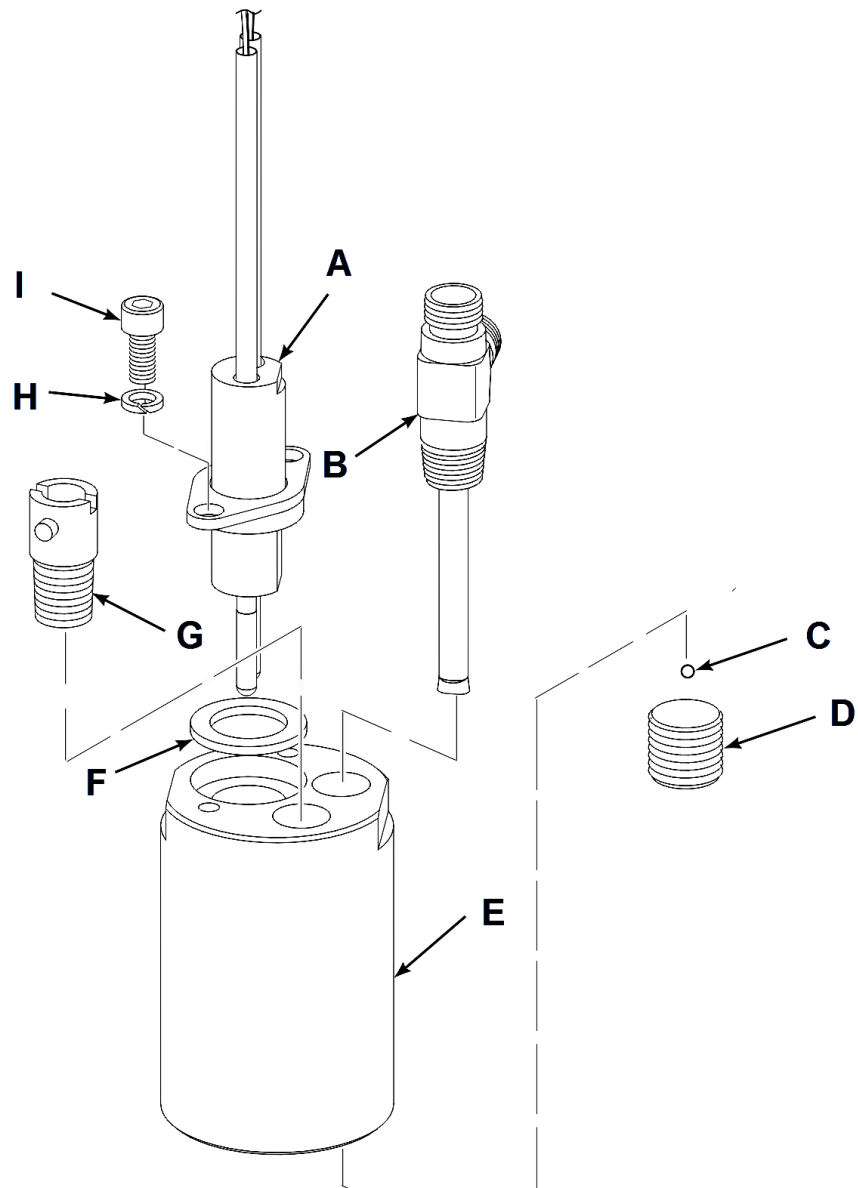

- A. COe sensor
- B. Pre-heater
- C. Stainless steel balls
- D. Plug
- E. Sensor holder
- F. Gasket
- G. Thermocouple adapter
- H. Lockwasher
- I. Screw

2. If it is damaged, use the following procedure to remove the thermocouple adaptor (G) from the sensor holder (E).
 - a) Use a propane torch to heat the thermocouple adapter to 450 °F (232 °C) minimum.
 - b) While heating, use a flat-head screwdriver to apply removal torque. Apply torque until the pipe thread sealant softens. Remove and discard the thermocouple adaptor.
 - c) Use MEK or methylene chloride solvent to clean the thread sealant residue from the internal pipe threads in the sensor holder.
Refer to the applicable material safety data sheet (MSDS) for solvent handling precautions.

⚠ CAUTION

Equipment damage

Turning the pre-heater in the sensor holder with the stainless steel balls in place will cause permanent damage to the pre-heater.

Always remove the stainless steel balls (approximately 200) from the sensor holder before removing or installing the pre-heater.

3. If removing the pre-heater (B), clamp the flats of the sensor holder (E) in vise jaws with plug (D) pointing up. Remove the plug. Unclamp the sensor holder and pour the stainless steel balls (C) into a container.

Note

Only remove the pre-heater when it or the sensor holder is damaged. If removal is not required, leave the pre-heater installed in the sensor holder.

4. Unthread and remove the pre-heater.
5. Use a cleaning solvent to thoroughly clean the stainless steel balls (C) and pre-heater chamber in the sensor holder (E).
Refer to the applicable MSDS for solvent handling precautions.

10.3.2 Assemble sensor housing

Assemble COe sensor assembly

⚠ CAUTION

Equipment damage

Turning the pre-heater in the sensor holder with the stainless steel balls in place will cause permanent damage to the pre-heater.

Always remove the stainless steel balls (approximately 200) from the sensor holder before removing or installing the pre-heater.

Procedure

1. If you removed the pre-heater (B, [Figure 10-15](#)), apply pipe thread sealant (Loctite #567) to the external pipe threads of the pre-heater (B) and plug (D).
Do not apply sealant to the first turn of the pipe threads.

2. Clamp flats of sensor holder (E) in vise jaws with the pre-heater port pointing up.
3. Install and tighten the pre-heater (B). Align the pre-heater to the flat of the sensor holder (E) as shown in [Figure 10-17](#).

Figure 10-16: Thermocouple

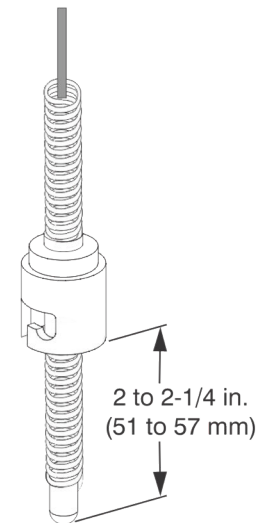
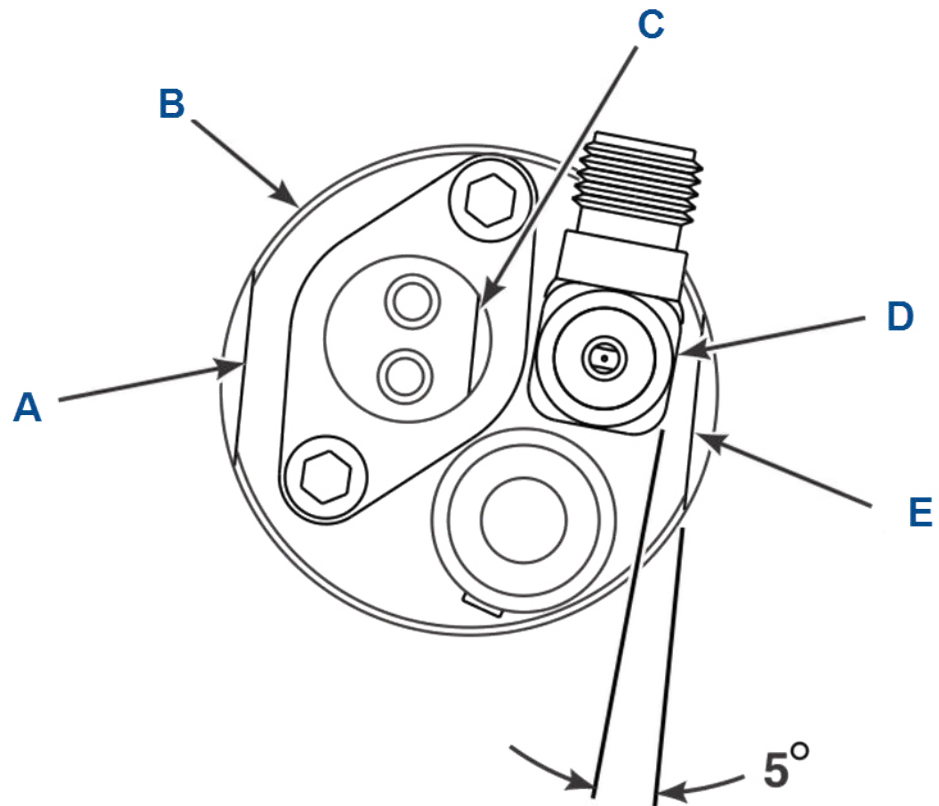

Figure 10-17: COe Sensor Assembly, Top View



- A. Sensor holder flat
- B. Sensor holder
- C. COe sensor flat
- D. Pre-heater flat
- E. Sensor holder flat

4. Invert the sensor holder (E, Figure 10-15) in a vise and pour stainless steel balls (C) into plug port. Press down on stainless steel balls and tap sensor holder with plastic hammer to compact balls in pre-heater chamber.
5. Install and tighten the plug.

CAUTION

Equipment damage

The resistance temperature device (RTD) elements are fragile, and correct alignment in sensor holder is required for proper Rosemount OCX8800 operation.

Use care when installing the combustibles (COe) sensor.

6. Lubricate and install the COe sensor gasket (F). Apply anti-seize compound to threads of screws.
7. Install COe sensor holder (A), lockwashers (I), and screws (J). Rotate flat of COe sensor (A) to center of sensor holder (E).

8. Align CO_e sensor flat parallel to sensor holder flat, as shown in [Figure 10-17](#). Tighten screws (J, [Figure 10-15](#)).
9. If replacing the thermocouple adapter (H), apply anti-seize to the pipe threads. Install and tighten the thermocouple adaptor.

Assemble O₂ sensor and heater strut assembly

Procedure

1. See [Figure 10-14](#). Assemble O₂ cell, gasket, and heater tube. Make sure the test gas passage holes line up with each other in all components.
2. Apply a small amount of anti-seize compound to the screw threads and use screws to secure the assembly. Torque to 35 in.-lb. (4 N-m).
3. Carefully slide the O₂ heater strut assembly into the heater tube.
4. Press down on the back plate of the strut bracket to ensure the spring tension is present to hold the contact pad against the O₂ cell.
5. Secure the strut bracket and return wire with four screws and lockwashers. Make sure the return wire is tightly fastened.
This is the ground side connection for the O₂ cell.

Install sample and exhaust tubes

Procedure

1. See [Figure 10-13](#). Apply pipe thread sealant (Loctite #567) to the replacement sample tube (C) or exhaust tube (B) pipe threads.
Do not apply sealant to the first turn of the pipe threads.
2. Thread the sample tube (C) or exhaust tube (B) into the housing. Use a pipe wrench to tighten the tube.
3. If used, install and tighten the in-situ filter (D).

Install eductor

Prerequisites

If installed, the O₂ cell and heater strut assembly ([Figure 10-8](#)) must be removed from sensor housing before you install the eductor.

Procedure

1. Apply pipe thread sealant (Loctite #567) to the external pipe threads of the eductor (G, [Figure 10-18](#)).
Do not apply sealant to the first turn of the pipe threads.

Figure 10-18: Installation of Eductor and COe Sensor

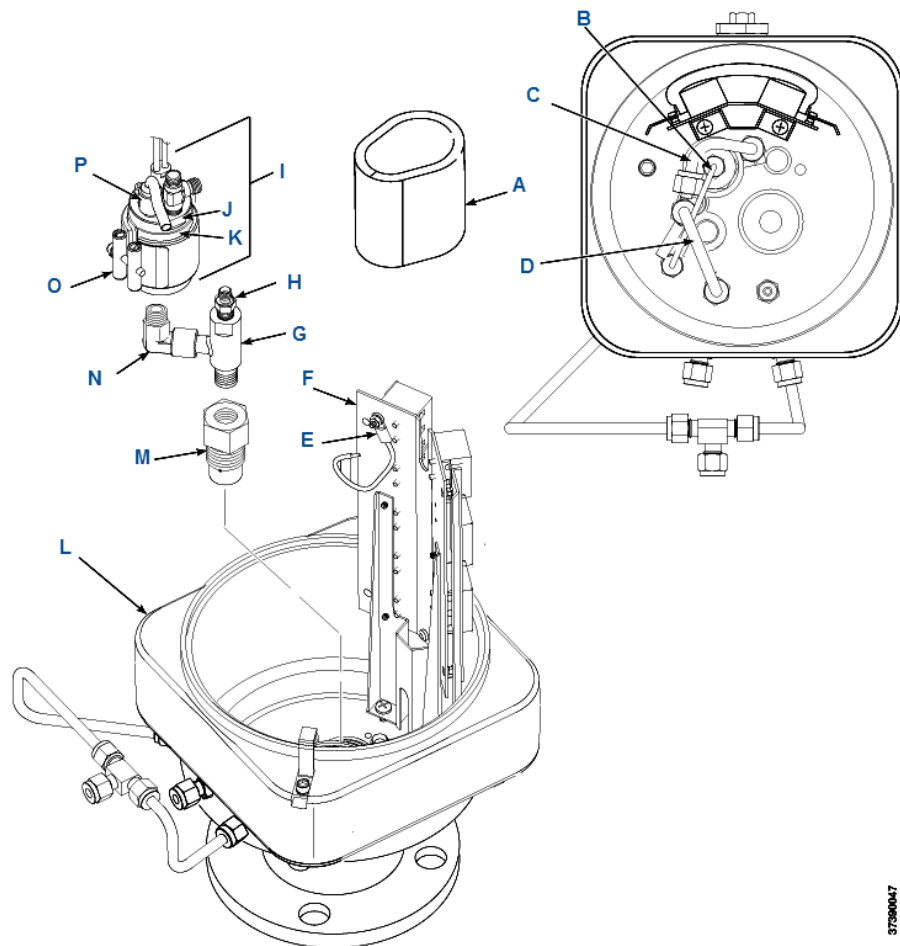

37390047

- A. Insulator
- B. Eductor air tube
- C. COe extractive tube
- D. Dilution air tube
- E. CJC sensor
- F. Terminal block mounting
- G. Eductor
- H. Tube fitting
- I. COe sensor assembly
- J. Sensor holder
- K. Heater insulator
- L. COe thermocouple
- M. COe band heater
- N. Eductor elbow
- O. Eductor holder
- P. Sensor housing

2. Install and tighten the eductor (G) in the eductor holder (O).

3. Install and tighten the elbow (N) on the eductor (G).
The male part of the elbow must point up and be in line with the long axis of eductor.
4. Apply anti-seize component to the external pipe threads of eductor holder (O).
5. Install and tighten eductor holder (O) in sensor housing (P). Align eductor with matchmark, as shown in [Figure 10-19](#).

Figure 10-19: Eductor Alignment Matchmarks

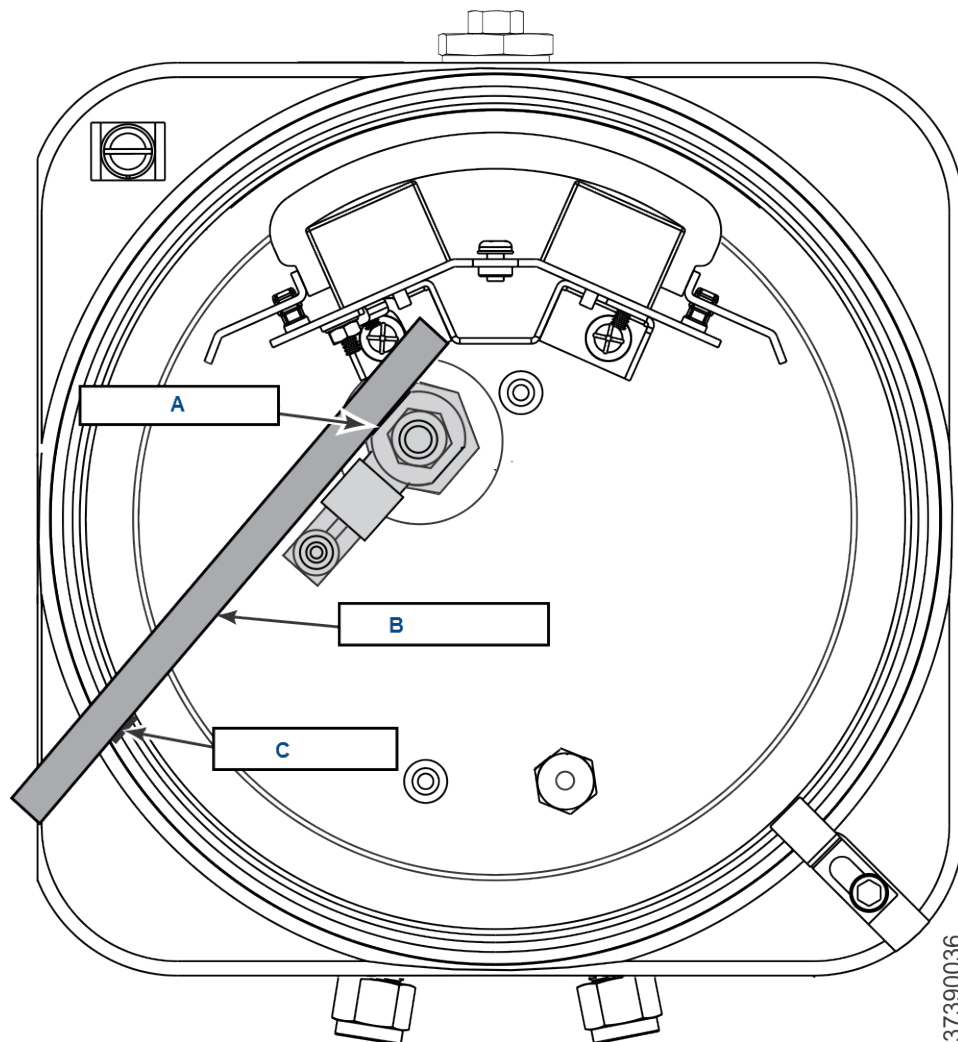

- A. Eductor flat
- B. Straight edge
- C. Matchmark

37390036

Install COe sensor assembly

Figure 10-20: Band Heater Height

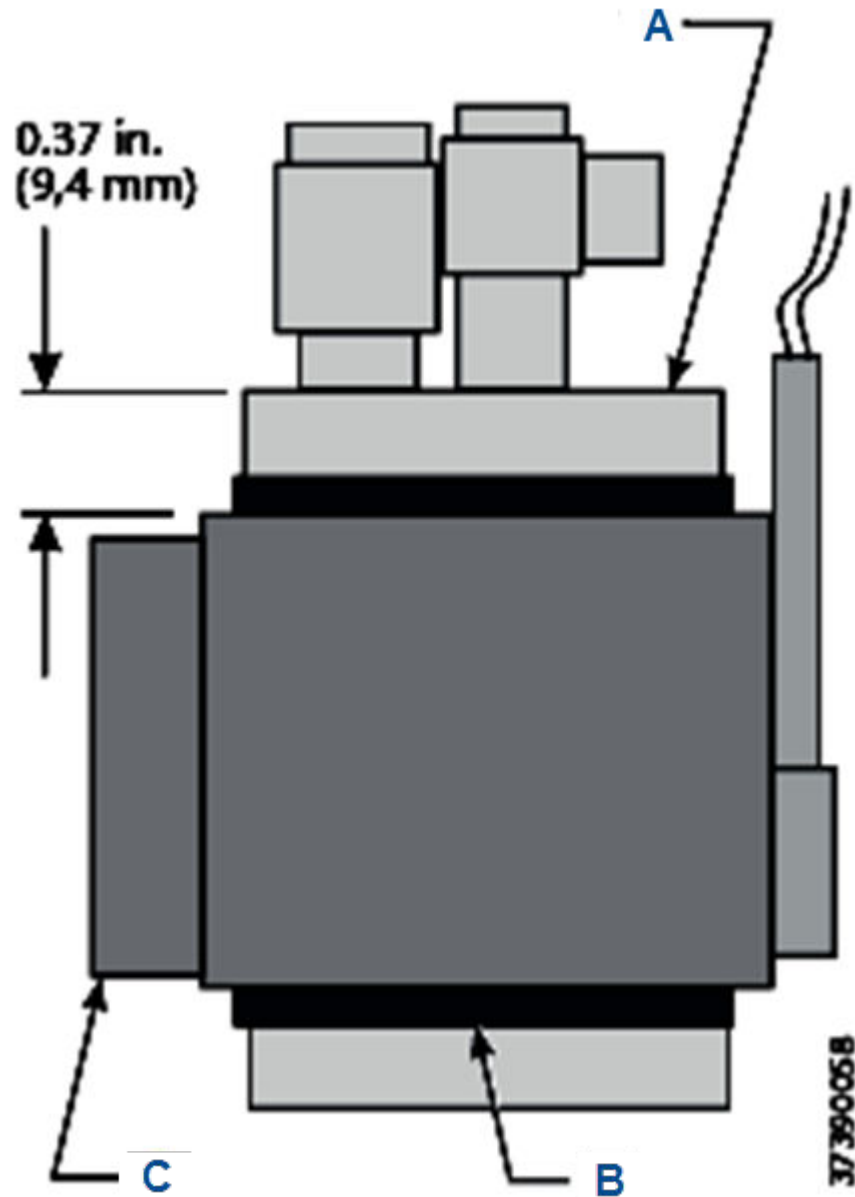

- A. COe sensor
- B. Insulator
- C. Band heater

Procedure

1. Apply pipe thread sealant (Loctite #567) to the exposed pipe threads of eductor elbow (Figure 10-18).
Do not apply sealant to the first turn of the pipe threads.
2. Screw the sensor holder onto the eductor elbow.
3. With wrenches on eductor elbow and on flats of sensor holder, tighten the sensor holder.
Do not allow the eductor elbow to turn.
4. Tighten the sensor holder to align outside flat with matchmark on sensor housing flange, as shown in Figure 10-21.

Figure 10-21: COe Sensor Holder Alignment

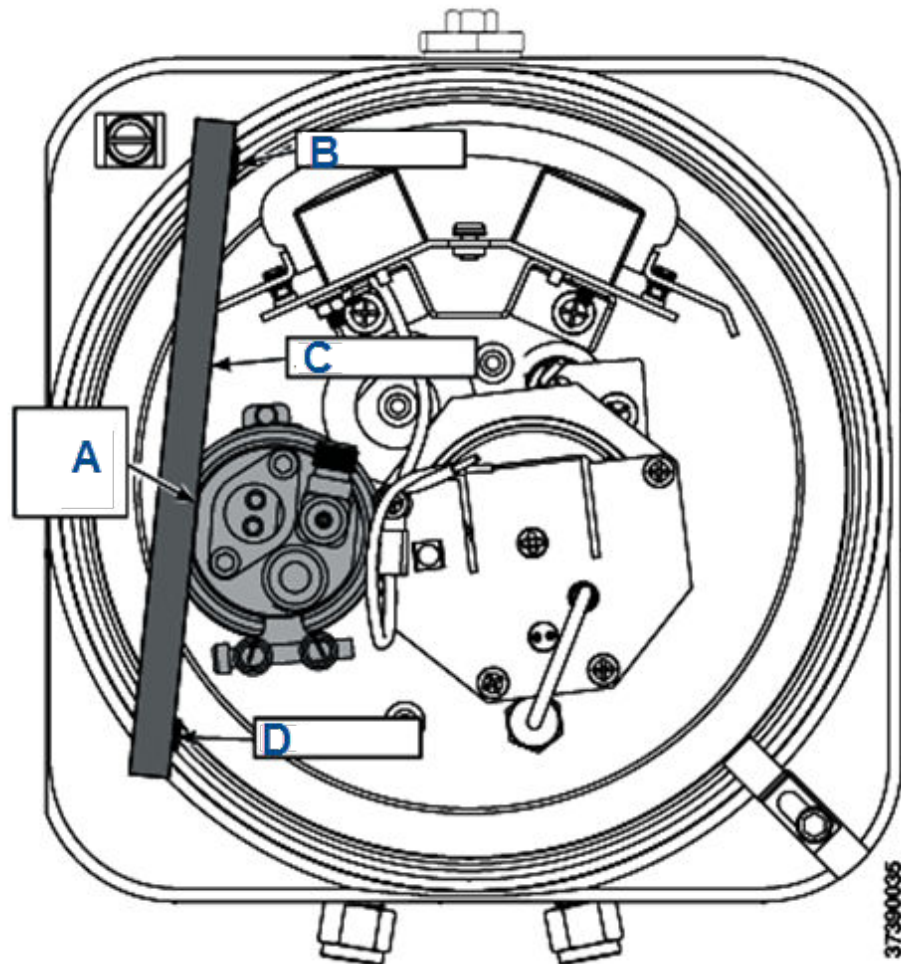

- A. Sensor holder flat
- B. Matchmark
- C. Straight edge
- D. Matchmark

⚠ CAUTION

Equipment damage

The heater insulator prevents current leakage between the band heater and the sensor holder. Failure to properly install the insulator may cause the device to trip a ground fault interrupt circuit.

5. Wrap heater insulator around sensor holder. Make sure the insulator joint lines up with the band gap of the COe band heater.
6. Slide the COe band heater ([Figure 10-18](#)) up onto sensor holder.
Do not tighten the band heater at this time. The heater must rotate freely around the sensor holder.
7. Check for proper height of COe heater thermocouple ([Figure 10-17](#)). Thread bayonet connector up or down to adjust height.
8. Install and fasten thermocouple ([Figure 10-18](#)).
9. Position band heater as shown in [Figure 10-20](#) and [Figure 10-21](#) and tighten band heater clamp screw.
The heater insulator end joint must line up with the band gap of the COe band heater.
10. Reconnect the COe sensor, thermocouple, and heater wires at the sensor housing terminal blocks.
Refer to [Figure 10-22](#).

Figure 10-22: COe Sensor, Thermocouple, and Heater Connections

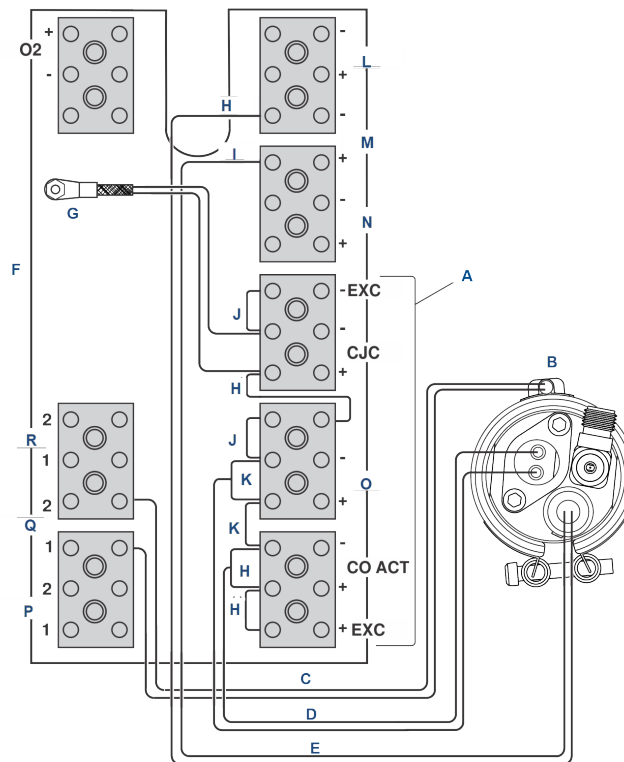

- A. All wires at these terminals are in the CJC current loop.
- B. COe sensor assembly
- C. COe heater wires
- D. COe sensor wires
- E. COe thermocouple wires
- F. Sensor housing terminals
- G. CJC sensor
- H. Red
- I. Yellow
- J. Blue
- K. White
- L. Thermocouple O₂
- M. Thermocouple CO
- N. Thermocouple sample block
- O. CO reference
- P. Heater sample block
- Q. Heater CO
- R. Heater O₂

11. Install and fasten the COe insulator (Figure 10-18) around the COe sensor assembly. All wiring must remain outside of the insulator.
12. If terminal block mounting (Figure 10-18) was moved, reinstall it with two base mounting screws.

Install sample block heater rods

Figure 10-23: Installation of O₂ Cell and Heater Strut Assembly

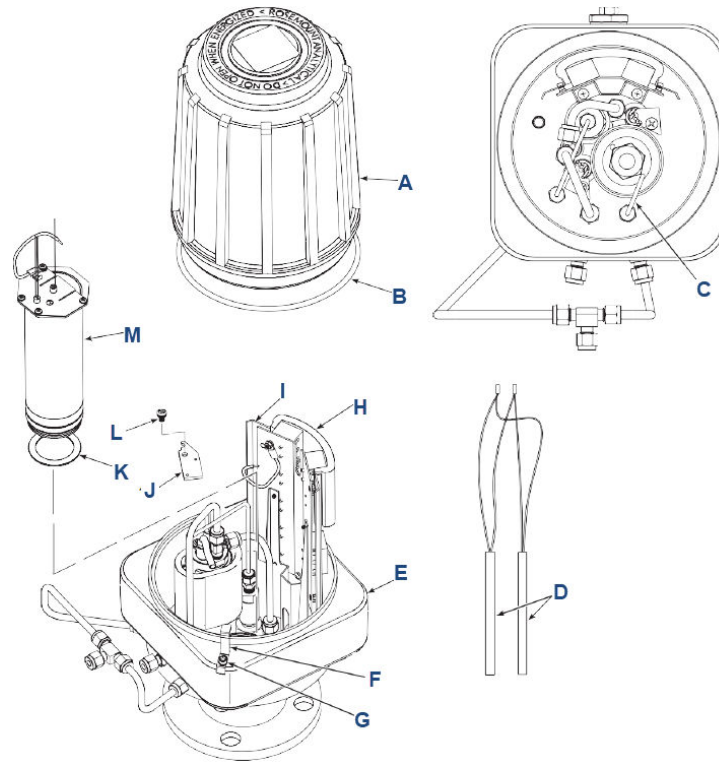

- A. Cover
- B. O-ring
- C. Reference air tube
- D. Heater rod
- E. Sensor housing
- F. Locking clip
- G. Screw
- H. Terminal insulator
- I. Marking plate
- J. Heater rod
- K. Gasket
- L. Screw
- M. Heater strut assembly

Procedure

1. Before installing sample block heater rods, evenly coat the heater rods with Watlube heater release agent.
See [Figure 10-23](#)
2. Install the heater rods, heater clamps, and screws.
3. Reconnect the heater rod leads at the housing terminal blocks.

Figure 10-24: O₂ Cell, Thermocouple, and Heater Connections

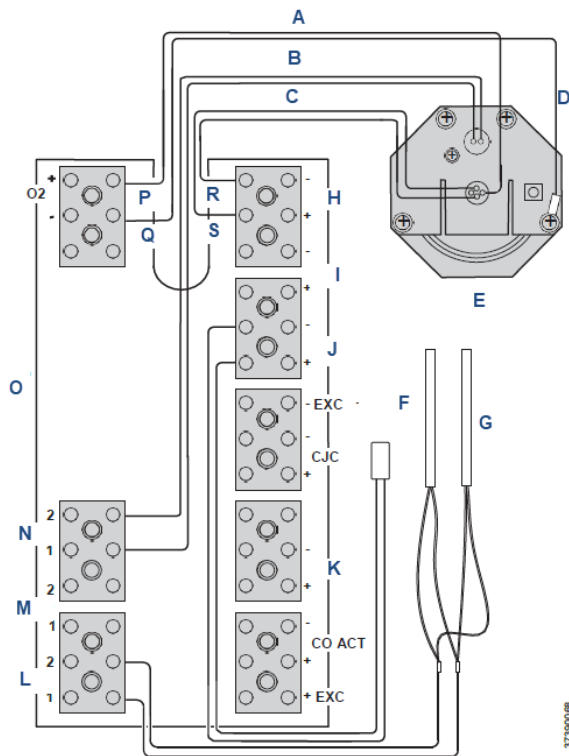

- A. O₂ cell wires
- B. O₂ heater wires
- C. Thermocouple wires
- D. Return wire
- E. O₂ cell and heater strut assembly
- F. Sample block thermocouple
- G. Sample block heater rods
- H. Thermocouple O₂
- I. Thermocouple CO
- J. Thermocouple sample block
- K. CO reference
- L. Heater sample block
- M. Heater CO
- N. Heater O₂
- O. Sensor housing terminals
- P. Orange
- Q. Green
- R. Red
- S. Yellow

Install O₂ cell and heater strut assembly

Procedure

1. Rub a small amount of anti-seize compound on both sides of new gasket.
See [Figure 10-23](#)
2. Apply anti-seize compound to threads of O₂ cell and heater strut assembly and sensor housing.

⚠ CAUTION

EQUIPMENT DAMAGE

Stripped threads on the O₂ cell and heater strut assembly can allow gas leakage. Gas leakage can affect the O₂ measurements and calibration.

Avoid over-tightening the O₂ cell and heater strut assembly.

3. Install O₂ cell and heater strut assembly in sensor housing. Snug up, but do not over-tighten the assembly.
4. Reconnect the lead wires from O₂ cell, heater, and thermocouple to the sensor housing terminal blocks.
Refer to [Figure 10-24](#)
5. Install reference air tube in sensor housing.
See [Figure 10-23](#)
Make sure that the open end of reference air tube extends into heater tube of O₂ cell and heater strut assembly.

Install terminals insulator and cover

Procedure

1. Install insulator over uppermost terminal blocks. Position one side of insulator against terminal blocks and snap terminal marking plate to mating stand-off.
See [Figure 10-23](#)
2. Position opposite side of insulator and secure with related marking plate.
3. If removed, install cover gasket. Screw cover (A) onto sensor housing (H). Tighten cover firmly.
4. Align locking clip with gap between cover ribs.
5. Loosen screw and slide locking clip fully into gap between cover ribs. Retighten screw.

Leak test sensor housing

Procedure

1. Install ¼ national pipe thread (NPT) cap on dilution air fitting. Install a ¼ NPT cap on sample tube (C, [Figure 10-13](#)) or plug ¼ NPT sample inlet port.
Capped or plugged ports must be air tight.
2. If not in place, install exhaust tube (B, [Figure 10-13](#)) in exhaust port according to instructions provided.
3. Connect a calibrated manometer to the **CAL GAS** inlet port.

4. Connect and apply clean instrument air at 35 psig (241 kPa) to the instrument air inlet fitting.
5. Observe the manometer reading.
The reading should be from 10 to 13-in. (254 to 330.2 mm), water column (WC). Locate and correct leaks if the reading is less than 10-in. WC.

10.4 Repair electronics housing

Use the following procedures to remove damaged components from the transmitter electronics housing and to install new replacement parts.

Disassemble the transmitter only as needed to replace damaged components. Use the assembly procedures that apply to install replacement parts and reassemble the transmitter.

10.4.1 Disassemble electronics housing

Remove cover

Procedure

1. See [Figure 10-25](#). Loosen screw (L) and slide locking clip (K) away from cover (A). Retighten screw (L).

Figure 10-25: Removal/Installation of Electronics Housing Components

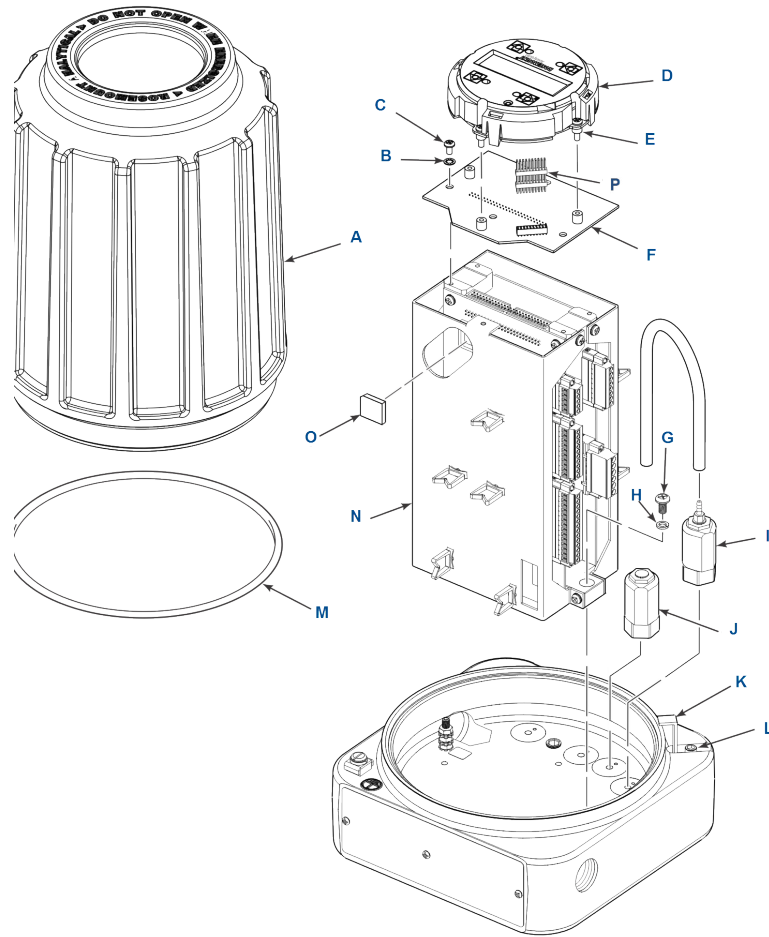

375900137

- A. Cover
- B. Lockwasher
- C. Screw
- D. Local operator interface (LOI) module
- E. Screw
- F. LOI board
- G. Screw
- H. Lockwasher
- I. Solenoid valve (three-way)
- J. Solenoid valve
- K. Locking clip
- L. Screw
- M. O-ring
- N. Electronics stack
- O. Flash PROM
- P. LOI connector

2. With two hands or strap wrench, turn cover (A) counterclockwise to loosen. Unthread and remove cover.
3. Inspect O-ring (M) for wear or damage. Replace O-ring if damaged.

Remove Flash PROM

⚠ CAUTION

EQUIPMENT DAMAGE

Use electrostatic discharge (ESD) protection to avoid damage to the electronic circuits.

Procedure

1. Locate the Flash PROM access port in the electronics stack (N, [Figure 10-25](#)).
2. Use a suitable IC removal tool to remove the Flash PROM (O).

Remove local operator interface (LOI) module and board

Procedure

1. Remove three screws (E, [Figure 10-25](#)).
2. Carefully lift LOI module (D) from LOI board (F).
Note the location of LOI connector (P).
3. Remove two screws (G) and lockwashers (H). Remove LOI board (F).

Remove electronics stack

Procedure

1. Unplug power cable, signal cable, and solenoid lead connectors from terminals of electronics stack (N, [Figure 10-25](#)).
2. Remove two screws (G) and lockwashers (H).
3. Remove electronics stack (N).

Remove solenoid valves

Procedure

1. Disconnect solenoid leads from mating terminal connector.
2. Remove top nut of solenoid valve (I or J, [Figure 10-25](#)).
3. Remove the solenoid coil assembly and washer.
4. Unthread and remove solenoid valve base.

Remove EMI filter and terminal block

Procedure

1. Disconnect EMI filter wiring ([Figure 10-26](#)) at terminal block (F).

Figure 10-26: Removal/Installation of EMI Filter

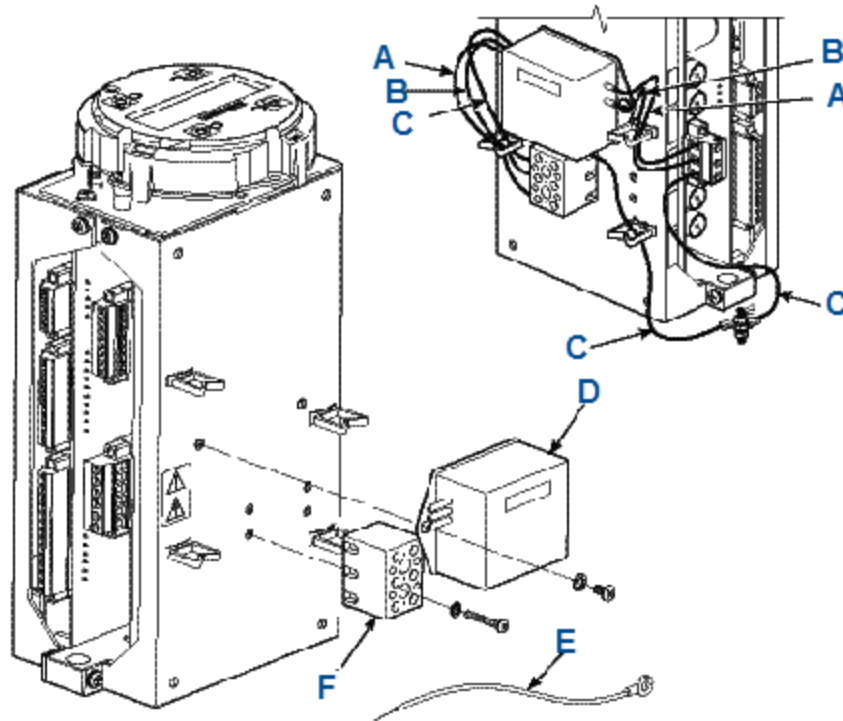

- A. Brown
- B. Blue
- C. Green
- D. EMI filter
- E. Ground wire
- F. Terminal block

2. Disconnect EMI filter wiring at AC power input terminal block on electronic stack.
3. Unbolt and remove EMI filter (D) from electronic stack.
4. Remove ground wire (E) from terminal block (F).
5. Unbolt and remove terminal block (F) from electronic stack.

10.4.2 Assemble electronics housing

Install EMI filter and terminal block

Procedure

1. Install replacement EMI filter (D, [Figure 10-26](#)) and/or terminal block (F) on electronic stack.
2. Refer to wiring details in [Figure 10-26](#). Connect EMI filter and ground wire (E) at terminal block (F).
3. Connect EMI filter wiring at AC power input terminal block on electronic stack.

Install solenoid valves

Procedure

1. Disassemble replacement solenoid valve (I or J, [Figure 10-25](#)).
2. Install new solenoid valve base.
Be careful not to overtighten.
3. Install new washer and solenoid coil assembly and secure with nut.
4. Connect the solenoid leads to the proper terminations on the solenoid power terminal block ([Figure 10-27](#)).

Figure 10-27: Solenoid Power Terminals

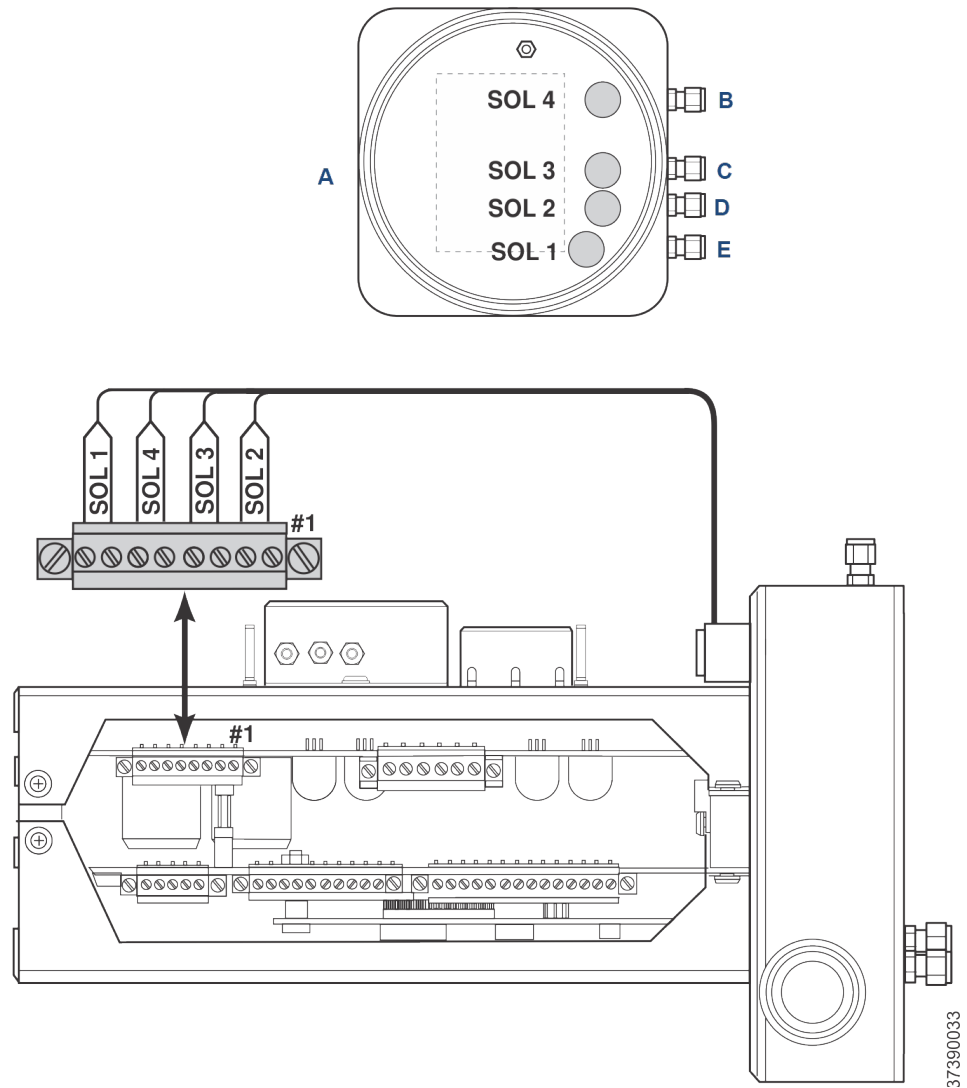

- A. Top view
- B. CO test gas
- C. High O₂ test gas
- D. Low O₂ test gas
- E. Instrument air

Install electronics stack

Procedure

1. Install electronics stack (N, [Figure 10-25](#)) and secure with lockwashers (H) and screws (G).
2. See [Figure 10-27](#) and [Figure 10-28](#). Reconnect power cable, signal cable, and solenoid lead connectors to electronics stack terminals.

Figure 10-28: Electronics Housing Cable Connections

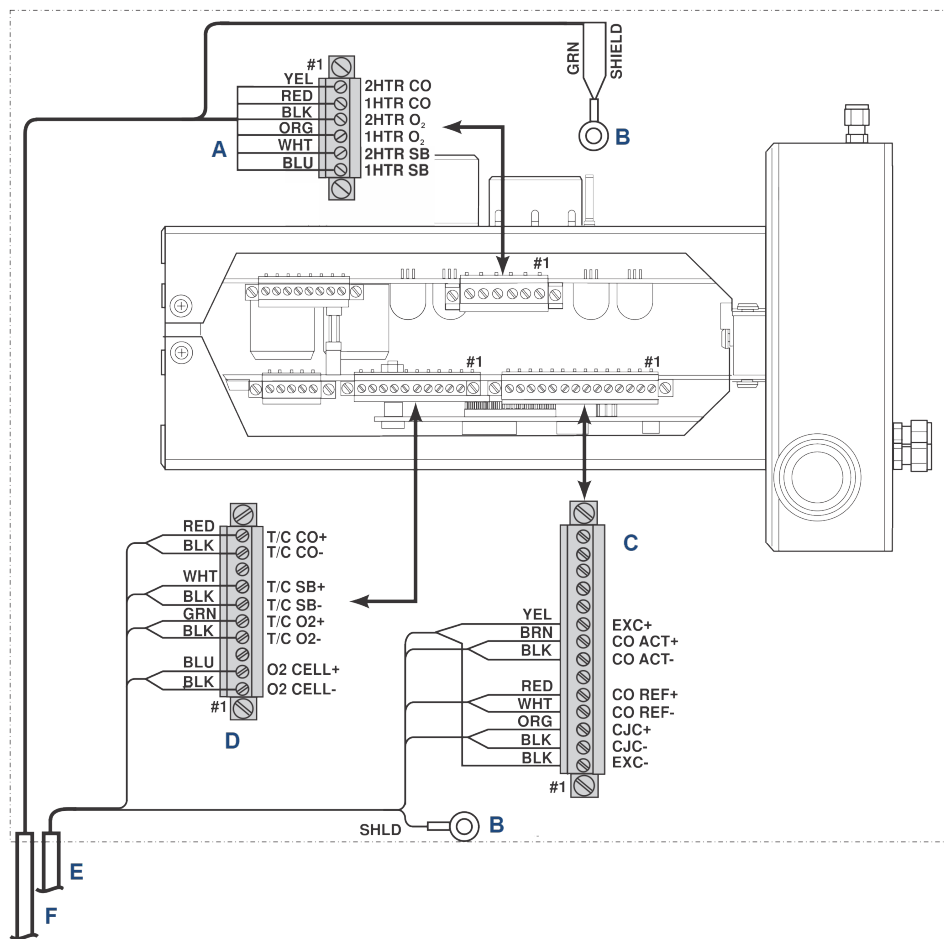

- A. Heater power connector (J3)
- B. To ground screw
- C. COe and CJC connector (J4)
- D. O₂ cell and thermocouple connector (J5)
- E. Signal cable
- F. Heater cable

Note

Wire colors shown are for cables supplied by Emerson.

Table 10-5: J3 Connections

Wire color	Connects to
Yellow	2 heater CO
Red	1 heater CO
Black	2 heater O ₂
Orange	1 heater O ₂
White	2 heater sample block (SB)

Table 10-5: J3 Connections (continued)

Wire color	Connects to
Blue	1 heater SB

Table 10-6: J4 Connections

Wire color	Connects to
Yellow	Exc+
Brown	CO act-
Black	CO act+
Red	CO reference+
White	CO reference-
Orange	CJC+
Black	CJC-
Black	Exc-

Table 10-7: J5 Connections

Wire color	Connects to
Red	Thermocouple (T/C) CO+
Black	T/C CO-
White	T/C SB+
Black	T/C SB-
Green	T/C O ₂ +
Black	T/C O ₂ -
Blue	O ₂ cell+
Black	O ₂ cell-

Install local operator interface (LOI) module and board

Procedure

1. Install LOI board (F, [Figure 10-25](#)) and secure it with two screws (G) and lockwashers (H).
2. Note the location of the LOI connector (P). Plug LOI module (D) and connector into one of the four mating receptacles provided.
3. Install three screws (E) to secure the LOI module.

Install flash PROM

Figure 10-29: Flash PROM Alignment

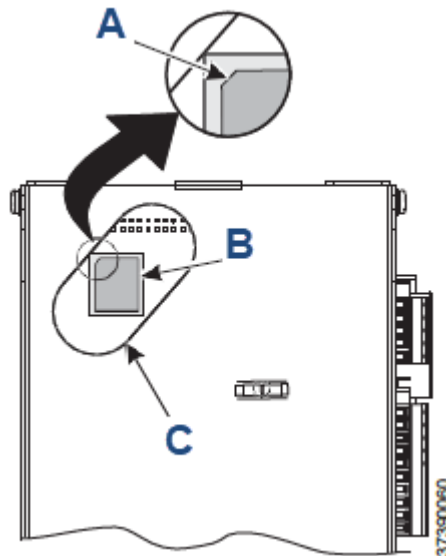

- A. Corner bevel
- B. Flash PROM
- C. Access port

⚠ CAUTION

EQUIPMENT DAMAGE

Use electrostatic discharge (ESD) protection to avoid damage to the electronic circuits.

Procedure

1. Locate the flash PROM access port in the electronics stack (N, [Figure 10-25](#)).
2. See [Figure 10-29](#). Align flash PROM (O, [Figure 10-25](#)) with mating receptacle in access port of electronics stack as shown.
Flash PROM corner bevel (A, [Figure 10-29](#)) must be in upper left corner of receptacle.
3. Install flash PROM.

Install cover

Procedure

1. If removed, install cover gasket.
 - a) Screw cover (A, [Figure 10-25](#)) onto electronics housing.
 - b) Tighten cover firmly.
 - c) Align locking clip (B) with gap between cover ribs.
2. Loosen screw and slide locking clip fully into gap between cover and ribs.
3. Retighten screw.

10.5 Replace tube fittings

The transmitter housings have special tube fittings that, if clogged or damaged, must be replaced with the same type of fitting. The special tube fittings have alpha or numeric codes etched on the fitting. Unetched tube fittings are standard ¼-in., stainless steel fittings.

E type fitting

The E type fitting is an eductor air drive fitting for the Rosemount OCX8800 general purpose sensor housing. It is a ⅛-in. tube fitting with a built-in 0.011-in. restrictor orifice. It seats in a threaded base port inside the housing.

R type fitting

The R type fitting is a reference air line fitting for the general purpose and hazardous area transmitter housings. This is a ¼-in. tube fitting with a built-in 0.007-in. restrictor orifice.

10.5.1 Remove tube fittings

The Rosemount OCX8800 construction includes pipe thread sealant to seal fittings in all ports that pass through to an outer wall of the instrument housing base. Use the following instructions to loosen and remove tube fittings that are secured with pipe thread sealant.

⚠ WARNING

Burns

The pipe threads are bonded with a pipe thread sealant. The thread sealant softens at 450 °F (232 °C). The heated parts can cause severe burns.

Use heat resistant gloves when removing a damaged tube fitting.

Figure 10-30: Removing Tube Fittings

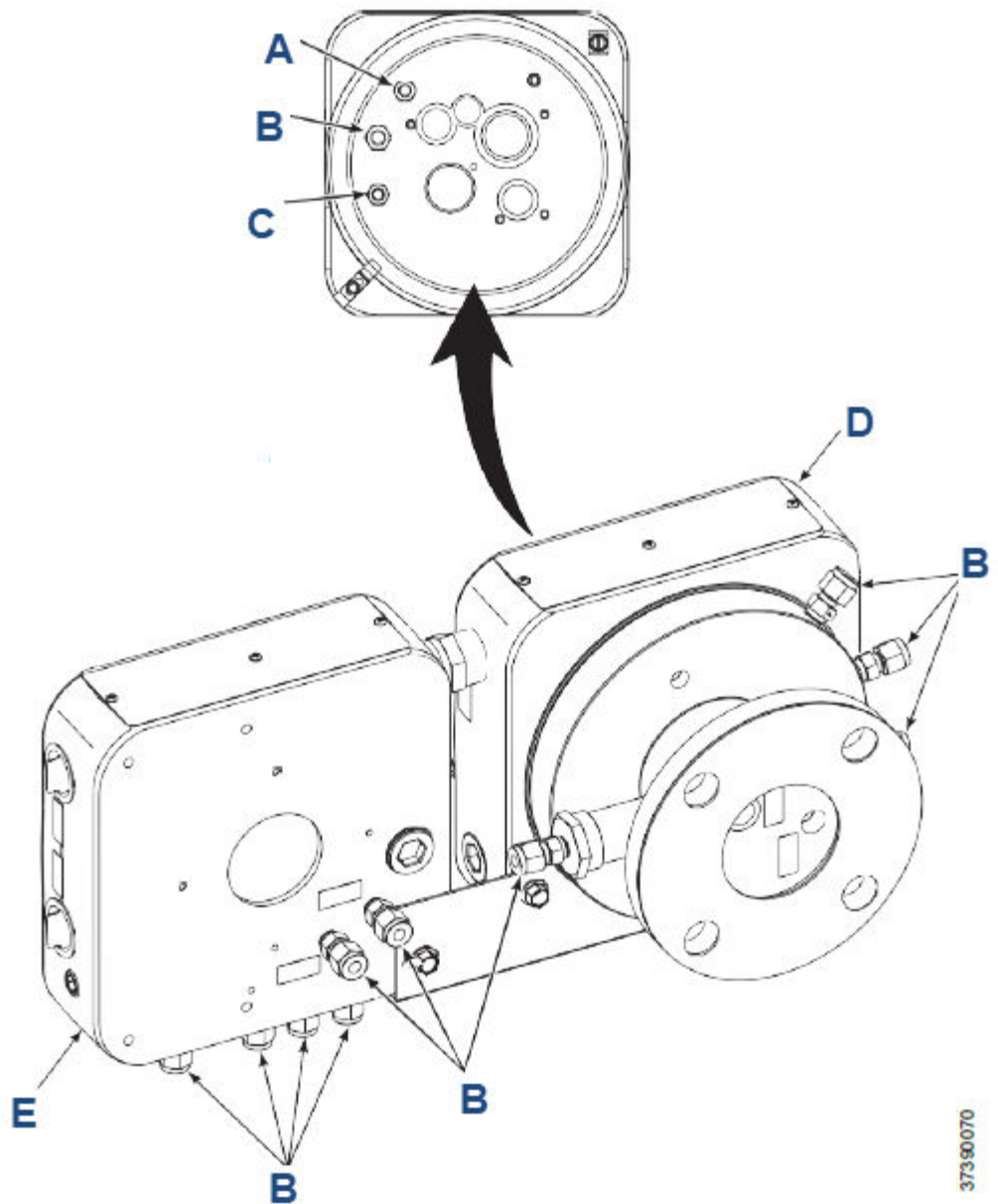

- A. Tube fitting (type E)
- B. Tube fitting
- C. Tube fitting (type R)
- D. Sensor housing
- E. Electronics housing

Procedure

1. Secure sensor housing or electronics housing in soft (plastic, wood, or brass) vice jaws.

2. To soften the pipe thread sealant, use a propane torch to heat the tube fitting to 450 °F (232 °C) minimum.
3. While heating the tube fitting, use a wrench to apply removal torque until the pipe thread sealant softens. Remove and discard the used fitting.
4. Use MEK or methylene chloride solvent to clean thread sealant residue from the internal pipe threads in the housing.
Refer to applicable material safety data sheet (MSDS) for solvent handling precautions.

10.5.2 Install tube fittings

Procedure

1. Verify that the replacement tube fitting is identical to the item removed.
Special fittings are etched with code markings.
2. Apply pipe thread sealant (Loctite #567) to the mating threads of the tube fitting.
Do not apply sealant to the first turn of the external pipe threads.
3. Install and tighten the tube fitting in the mating port of sensor or electronic housing.

11 Replacement parts

11.1 Sensor housing

Figure 11-1: Sensor Housing Components (Sheet 1 of 2)

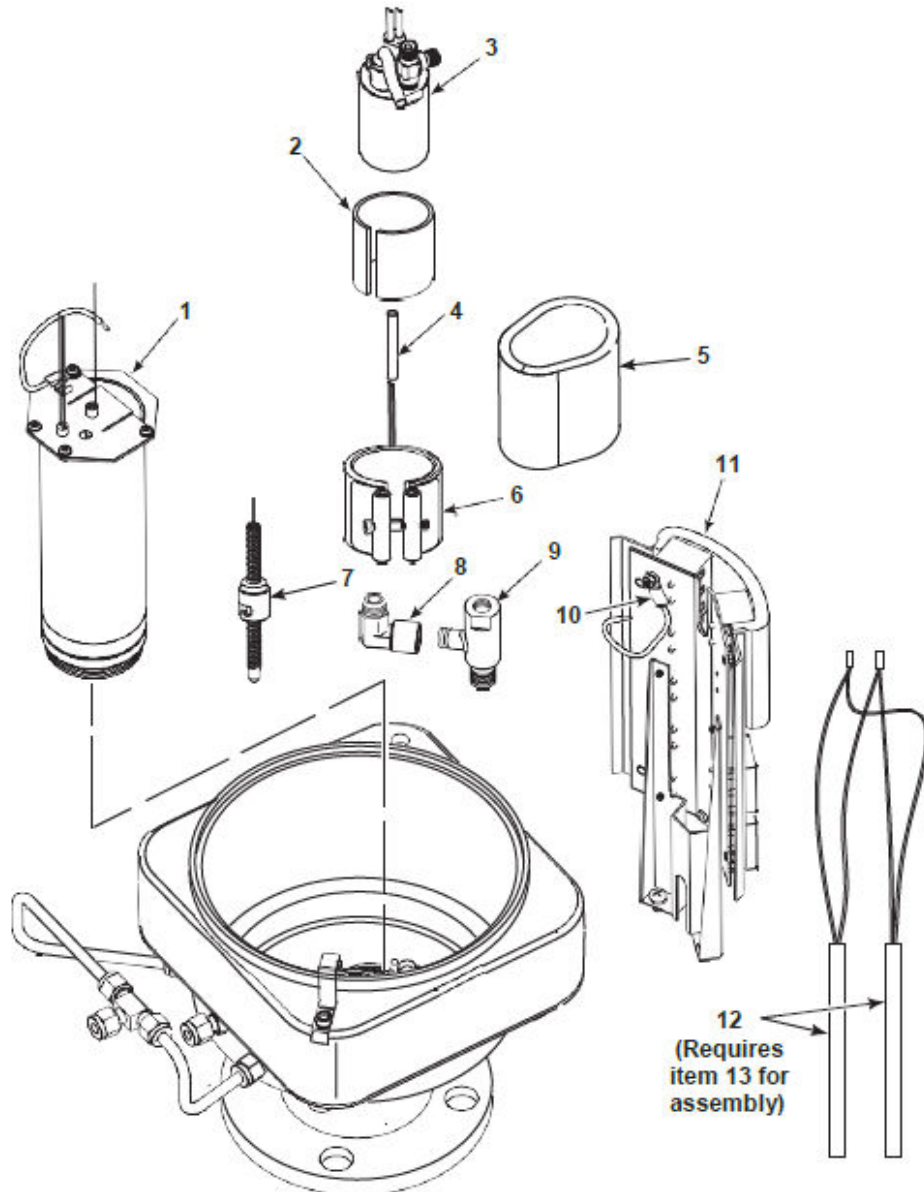

37390072

Table 11-1: Sensor Housing Components (Sheet 1)

Index number	Part number	Description
1	5R10190G02	O ₂ cell and heater assembly, standard cell
2	6P00177H01	Heat insulator, mica
3	4851B46G03	Combustibles sensor replacement kit
4	1A99786H01	Heater leads insulator For transmitter with integral electronics: 14.5-in. (368.3 mm) long. For transmitter with remote electronics: 11-in. (279.4 mm) long.
5	6P00163H01	COe insulator
6	1A99746H02	Band heater
7	1A99749H01	Thermocouple
8	1A99747H01	Elbow
9	5R10200H01	Eductor
10	6A00123G01	CJC sensor (resistance temperature device [RTD] assembly, ring type)
11	6P00155H02	Insulator
12	1A98765H02	Heater rod
13	1A99520H01	Watlube heater release agent

Figure 11-2: Sensor Housing Components (Sheet 2 of 2)

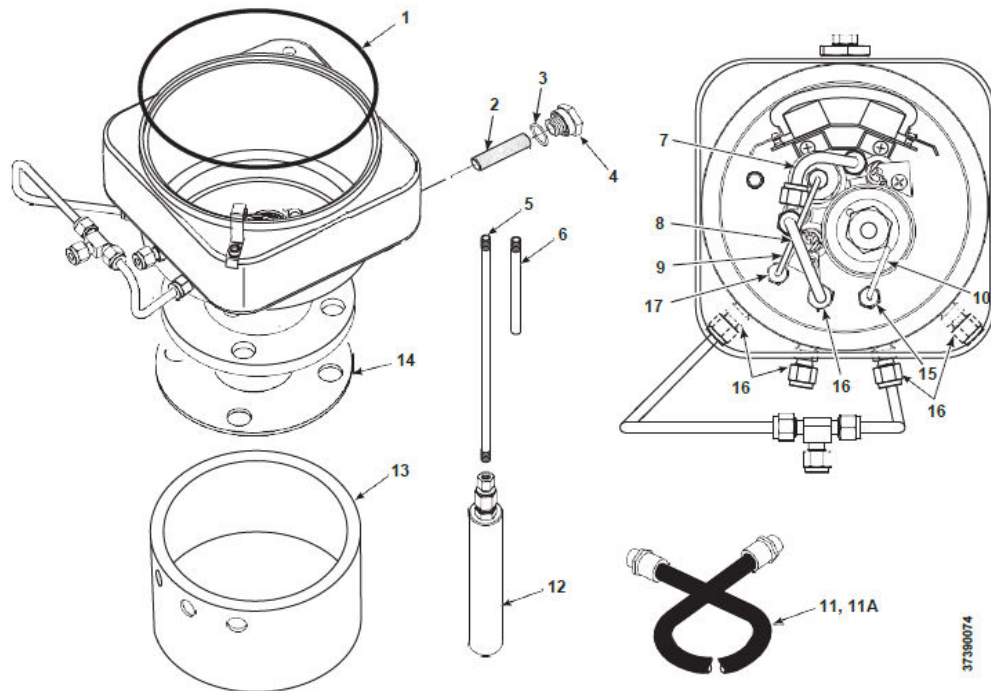

Table 11-2: Sensor Housing Components (Sheet 2)

Index number	Part number	Description
1	1A99089H02	Cover gasket (O-ring)
2	For transmitter with integral electronics: 5R10246H06 For transmitter with remote electronics: 5R10246H02	Blowback filter, stainless steel For transmitter with integral electronics: 5 micron For transmitter with remote electronics: 20 micron
3	1A98448H02	O-ring
4	5R10247H01	Fitting
5	5R10183H02	Tube, sample, 18-in. (457 mm) 316 stainless steel
	5R10183H06	Tube, sample, 18-in. (457 mm) Inconel 600
	5R10227G01	Tube, sample, 18-in. (457 mm) ceramic
	5R10183H03	Tube, sample, 3 ft. (0.91 m) 316 stainless steel
	5R10183H07	Tube, sample, 3 ft. (0.91 m) Inconel 600
	5R10227G02	Tube, sample, 3 ft. (0.91 m) ceramic
	5R10183H04	Tube, sample, 6 ft. (1.83 m) 316 stainless steel
	5R10183H08	Tube, sample, 6 ft. (1.83 m) Inconel 600
	5R10183H05	Tube, sample, 9 ft. (2.7 m) 316 stainless steel
	5R10183H09	Tube, sample, 9 ft. (2.7 m) Inconel 600
6	5R10183H01	Tube, exhaust
7	5R10185H07	COe extractive tube
8	5R10185H08	Dilution air tube
9	5R10185H03	Eductor drive air tube
10	5R10185H04	Reference air tube
11	6A00146G01	Heater cable assembly, remote electronics, 20 ft. (6 m)
	6A00146G02	Heater cable assembly, remote electronics, 40 ft. (12 m)
	6A00146G03	Heater cable assembly, remote electronics, 60 ft. (18 m)
	6A00146G04	Heater cable assembly, remote electronics, 80 ft. (24 m)
	6A00146G05	Heater cable assembly, remote electronics, 100 ft. (30 m)
	6A00146G06	Heater cable assembly, remote electronics, 150 ft. (45 m)
	6A00147G02	Signal cable assembly, remote electronics, 40 ft. (12 m)

Table 11-2: Sensor Housing Components (Sheet 2) (continued)

Index number	Part number	Description
	6A00147G03	Signal cable assembly, remote electronics, 60 ft. (18 m)
	6A00147G04	Signal cable assembly, remote electronics, 80 ft (24 m)
	6A00147G05	Signal cable assembly, remote electronics, 100 ft. (30 m)
	6A00147G06	Signal cable assembly, remote electronics, 150 ft. (45 m)
12	1A99762H02	In-situ filter, 10 micron (stainless steel sample tube only)
	1A99762H03	Hasteloy in-situ filter, 10 micron, high temperature (stainless steel and Inconel sample tubes only)
13	6P00162H01	Flange insulator (optional)
14	3535B18H02	Flange gasket, ANSI
	3553B45H01	Flange gasket, DIN
15	5R10279G01	Tube fitting, type R
16	771B870H04	Tube fitting, standard
17	5R10279G02	Tube fitting, type E

11.2 Electronics housing

Figure 11-3: Electronics Housing Components for Rosemount OCX8800 with Integral Electronics

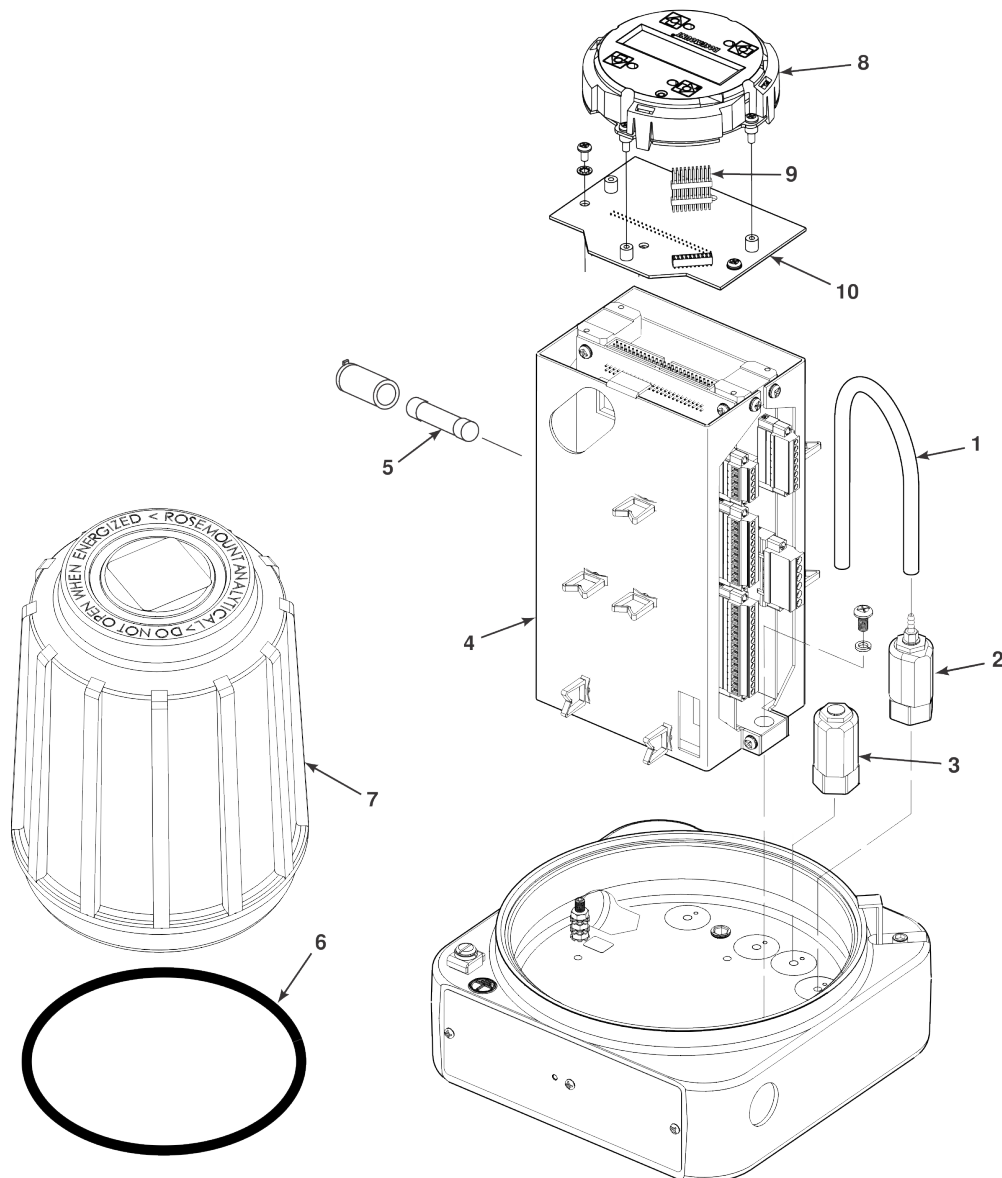

Table 11-3: Electronics Housing Components for Rosemount OCX8800 with Integral Electronics

Index number	Part number	Description
1	1A97902H01	Hose
2	1A97905H02	Solenoid valve, 3-way
3	1A97905H01	Solenoid valve, test gas

Table 11-3: Electronics Housing Components for Rosemount OCX8800 with Integral Electronics
(continued)

Index number	Part number	Description
4	6A00132G01	Electronics stack, HART®
5	1A97913H06	Fuse (F1 and F6), 10 amp, 250 Vac
	1A99766H01	Fuse (F3), 4 amp, 250 Vac
	1A99766H02	Fuse (F4), 8 amp, 250 Vac
6	1A99089H02	Cover gasket (O-ring)
7	5R10219G01	Cover, blind
7A	5R10199G01	Cover, window
8	6A00115G02	Local operator interface (LOI) module
9	1A99112H05	LOI connector
10	5R10235G01	LOI board

Figure 11-4: Electronics Housing Components for Rosemount OCX8800 with Remote Electronics

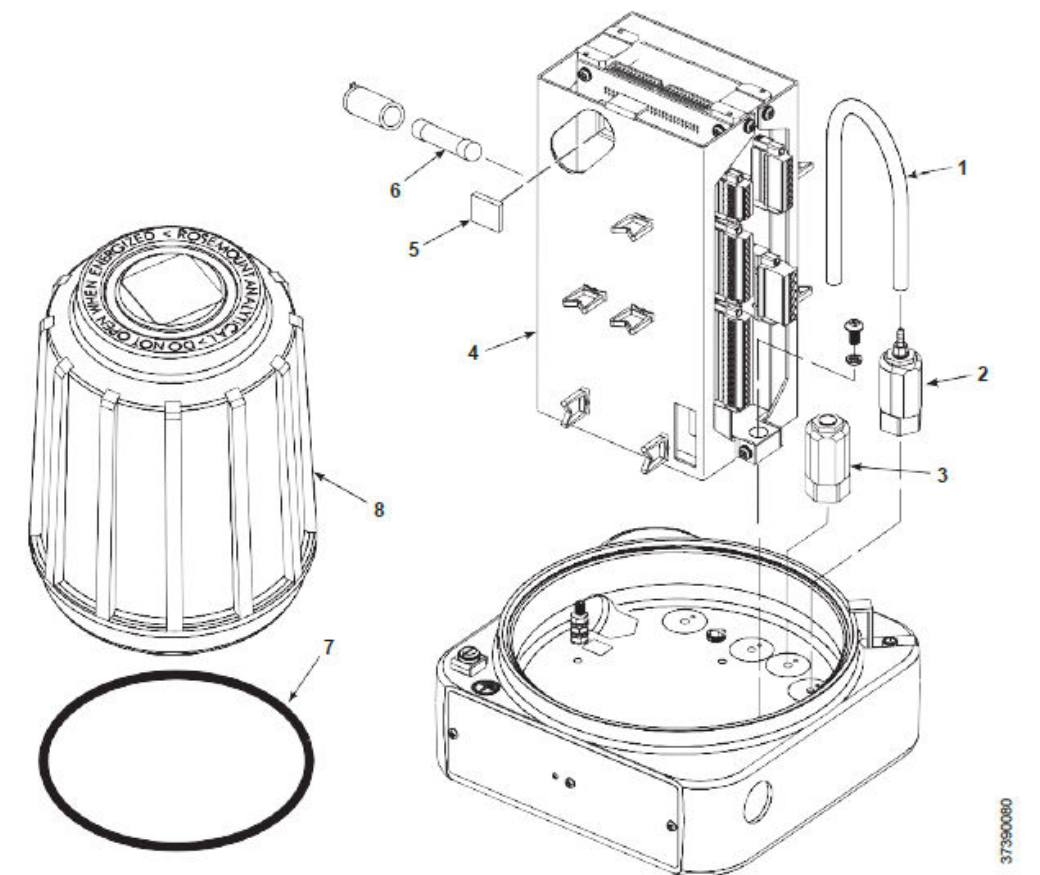
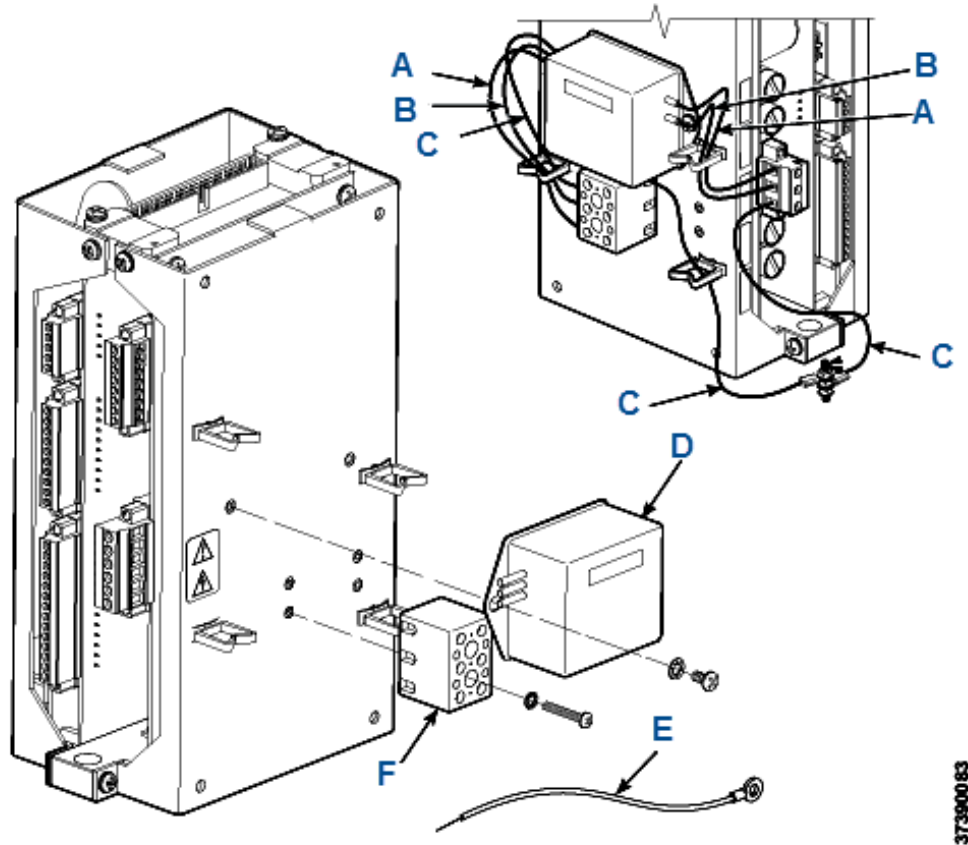

Table 11-4: Electronics Housing Components for Rosemount OCX8800 with Remote Electronics

Index number	Part number	Description
1	1A97902H01	Hose
2	1A97905H02	Solenoid valve, 3-way
3	1A97905H01	Solenoid valve, test gas
4	6A00132G01	Electronics stack, HART
5	Special order	Flash PROM, programmed
6	1A97913H06	Fuse (F1 and F6), 10 amp, 250 Vac
	1A99766H01	Fuse (F3), 4 amp, 250 Vac
	1A99766H02	Fuse (F4), 8 amp, 250 Vac
7	1A99089H02	Cover gasket (O-ring)
8	5R10219G01	Cover, blind
8A	5R10199G01	Cover, window

Figure 11-5: EMI Filter and Terminal Block



- A. Brown
- B. Blue
- C. Green
- D. Filter, EMI
- E. Ground Wire
- F. Terminal block

Table 11-5: EMI Filter and Terminal Block Parts

Index letter	Part number	Description
D	1A98467H01	Filter, EMI
E	5R10238G01	Ground wire
F	1A99714H01	Terminal block

11.3 O₂ cell and heater strut assembly

Figure 11-6: O₂ Cell and Heater Strut Assembly

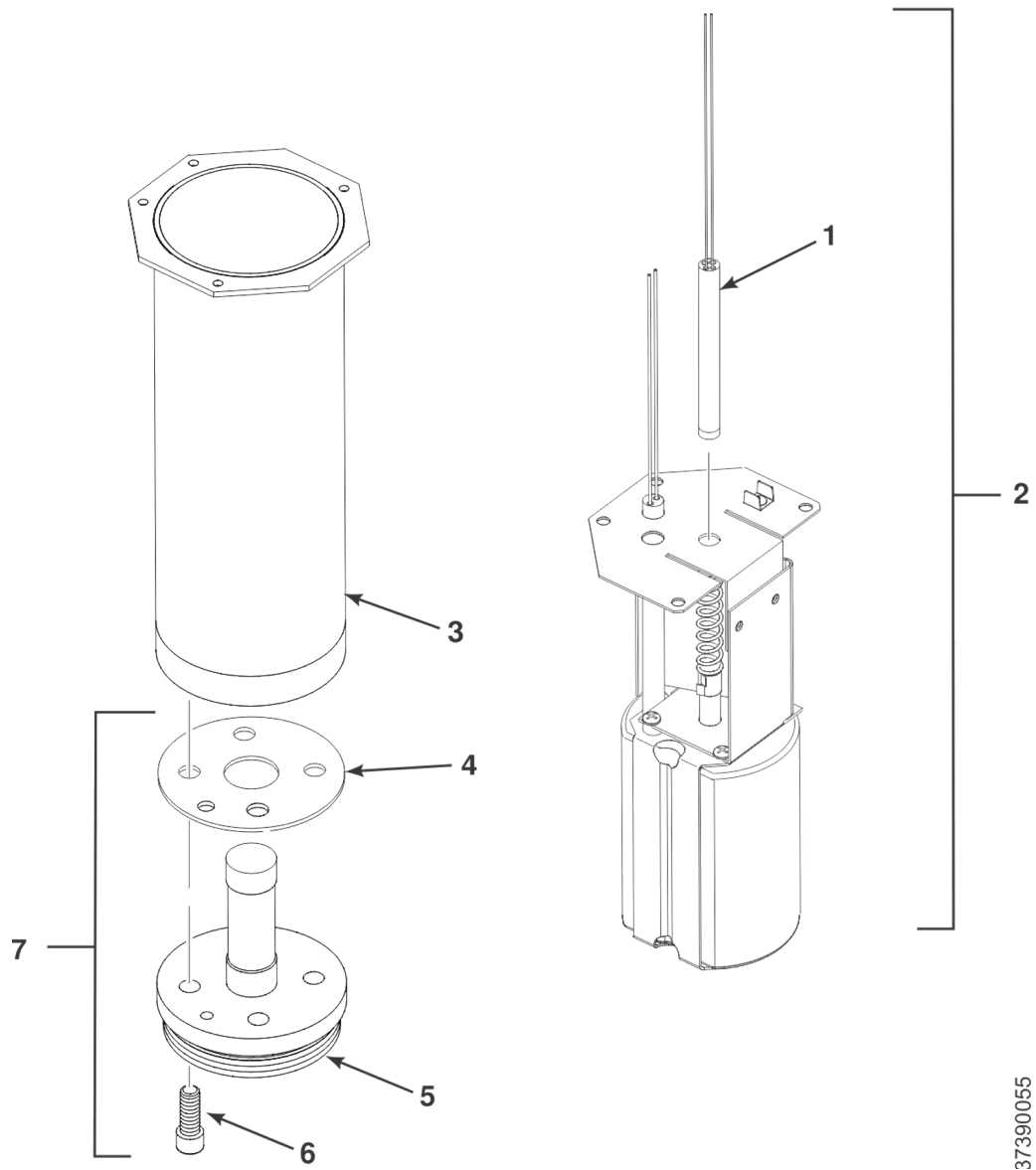

37390055

Table 11-6: O₂ Cell and Heater Strut Assembly

Index no.	Part number	Description
1	4851B44G01	Contact and thermocouple assembly
2	5R10211G02	Heater strut assembly
3	5R10188G01	Heater tube
4	Refer to item 7.	Gasket (part of O ₂ cell replacement kit, item 7)

Table 11-6: O₂ Cell and Heater Strut Assembly (continued)

Index no.	Part number	Description
5	Refer to item 7.	O ₂ cell (part of O ₂ cell replacement kit, item 7)
6	Refer to item 7.	Screw (part of O ₂ cell replacement kit, item 7)
7	4851B45G01	O ₂ cell replacement kit, standard sensing cell

A Safety data

A.1 Safety instructions

The following safety instructions apply specifically to all EU member states. They should be strictly adhered to in order to ensure compliance with the Low Voltage Directive. Non-EU states should also comply with the following unless superseded by local or national standards.

WARNING

Adequate earth connections should be made to all earthing points, internal and external, where provided.

After installation or troubleshooting, all safety covers and safety grounds must be replaced. The integrity of all earth terminals must be maintained at all times.

Main supply cords should comply with the requirements of IEC227 or IEC245.

All wiring shall be suitable for use in an ambient temperature of greater than 167 °F (75 °C).

All cable glands used should be of such internal dimensions as to provide adequate cable anchorage.

To ensure safe operation of this equipment, connection to the mains supply should only be made through a circuit breaker, which will disconnect all circuits carrying conductors during a fault situation. The circuit breaker may also include a mechanically operated isolating switch. If it does not, then another means of disconnecting the equipment from the supply must be provided and clearly marked as such. Circuit breakers or switches must comply with a recognized standard, such as IEC947. All wiring must conform with any local standards.

Where equipment or covers are marked with the symbol below, hazardous voltages are likely to be present beneath. These covers should only be removed when power is removed from the equipment - and then only by trained service personnel.



Where equipment or covers are marked with the symbol below, there is a danger of hot surfaces beneath. These covers should only be removed by trained service personnel when power is removed from the equipment. Certain surfaces may remain hot to the touch.



Where equipment or covers are marked with the symbol below, refer to the reference manual for instructions.



All graphical symbols used in this product are from one or more of the following standards: EN61010, IEC417, and ISO3864.

Where equipment or labels are marked "Do Not Open While Energized" or similar, there is a danger of ignition in areas where an explosive atmosphere is present. This equipment should only be opened when the power is removed and adequate time as specified on the label or in the Reference Manual has been allowed for the equipment to cool down - and then only by trained service personnel.

⚠ WARNING

Physical access

Unauthorized personnel may potentially cause significant damage to and/or misconfiguration of end users' equipment. This could be intentional or unintentional and needs to be protected against.

Physical security is an important part of any security program and fundamental in protecting your system. Restrict physical access by unauthorized personnel to protect end users' assets. This is true for all systems used within the facility.

A.2 Safety data sheet for ceramic fiber products

July 1, 1996

A.2.1 Identification

Product name	Ceramic fiber heaters, molded insulation modules, and ceramic fiber radiant heater panels
Chemical family	Vitreous aluminosilicate fibers with silicon dioxide
Chemical name	N/A
Chemical formula	N/A
Manufacturer's name and address	Watlow Columbia 2101 Pennsylvania Drive Columbia, MO 65202 Phone: 573-814-1300, ext. 5170 Fax: 573-474-9402
Health hazard summary warning	<ul style="list-style-type: none">• Possible cancer hazard based on tests with laboratory animals.• May be irritating to skin, eyes, and respiratory tract.• May be harmful if inhaled.• Cristobalite (crystalline silica) formed at high temperature (above 1800 °F [982 °C]) can cause severe respiratory diseases.

A.2.2 Physical data

Appearance and odor	Cream to white colored fiber shapes. With or without optional white to gray granular surface coating and/or optional black surface coating.
Specific weight	12 to 25 lb./cubic foot
Boiling point	N/A
Volatiles (percent by weight)	N/A
Water solubility	N/A

A.2.3 Hazardous ingredients

Table A-1: Material, Quantity, and Threshold Exposure Limit Values

Aluminosilicate (vitreous) 99 + %	1 fiber/cc TWA
CAS No. 142844-00-06	10 fibers/cc CL
Zirconium silicate	0-10% 5 mg/cubic meter (TLV)
Black surface coating ⁽¹⁾	0-1% 5 mg/cubic meter (TLV)
Amorphous silica/silicon dioxide	0-10% 20 mppcf (6 mg/cubic meter) PEL (OSHA 1978) 3 gm cubic meter (Respirable dust): 10 mg/cubic meter, intended TLV (ACGIH 1984-1985)

(1) Composition is a trade secret.

Effects of over exposure

- Eye: Avoid contact with eyes. Slightly to moderately irritating. Abrasive action may cause damage to outer surface of eye.
- Inhalation: May cause respiratory tract irritation. Repeated or prolonged breathing of particles of respirable size may cause inflammation of the lung leading to chest pain, difficulty breathing, coughing, and possible fibrotic change in the lung (pneumoconiosis). Pre-existing medical conditions may be aggravated by exposure: specifically, bronchial hyper-reactivity and chronic bronchial or lung disease.
- Ingestion: May cause gastrointestinal disturbances. Symptoms may include irritation and nausea, vomiting, and diarrhea.
- Skin: Slightly to moderately irritating. May cause irritation and inflammation due to mechanical reaction to sharp, broken ends of fibers.

Exposure to used ceramic fiber product

Product which has been at service in elevated temperatures (greater than 1800 °F/982 °C) may undergo partial conversion to cristobalite, a form of crystalline silica which can cause severe respiratory disease (pneumoconiosis). The amount of cristobalite present will depend on the temperature and length of time in service.

See [Special protection information](#) for permissible exposure levels.

Special toxic effects

The existing toxicology and epidemiology data bases for refractory ceramic fibers (RCFs) are still preliminary. Information will be updated as studies are completed and reviewed. The following is a review of the results to date:

Epidemiology

At this time, there are no known published reports demonstrating negative health outcomes of workers exposed to RCF. Epidemiologic investigation of RCF production workers are ongoing.

1. There is no evidence of any fibrotic lung disease (interstitial fibrosis) whatsoever on x-ray.
2. There is no evidence of any lung disease among those employees exposed to RCF that had never smoked.
3. A statistical trend was observed in the exposed population between the duration of exposure to RCF and a decrease in some measures of pulmonary function. These

observations are clinically insignificant. In other words, if these observations were made on an individual employee, the results would be interpreted as being within the normal range.

4. Pleural plaques (thickening along the chest wall) have been observed in a small number of employees who had a long duration of employment. There are several occupational and non-occupational causes for pleural plaque. It should be noted that plaques are not pre-cancer, nor are they associated with any measurable effect in lung function.

Toxicology

A number of studies on the health effects of inhalation exposure of rats and hamsters are available. Rats were exposed to RCF in a series of life-time nose-only inhalation studies. The animals were exposed to 30, 16, 9, and 3 mg/m³, which corresponds with approximately 200, 150, 75, and 25 fibers/cc.

Animals exposed to 30 and 16 mg/m³ were observed to have developed a pleural and parenchymal fibrosis; animals exposed to 9 mg/m³ had developed a mild parenchymal fibrosis; animals exposed to the lowest dose were found to have the response typically observed any time a material is inhaled into the deep lung. While a statistically significant increase in lung tumors was observed following exposure to the highest dose, there were no excess lung cancers at the other doses. Two rats exposed to 30 mg/m³ and one rat exposed to 9 mg/m³ developed mesotheliomas.

The International Agency for Research on Cancer (IARC) reviewed the carcinogenicity data on man-made vitreous fibers (including ceramic fiber, glasswool, rockwool, and slagwool) in 1987. IARC classified ceramic fibers, fibrous glasswool, and mineral wool (rockwool and slagwool) as possible human carcinogens (Group 2B).

A.2.4 Fire and explosion data

Flash point	None
Flammability limits	N/A
Extinguishing media	Use extinguishing agent suitable for type of surrounding fire.
Unusual fire and explosion hazards / special fire fighting procedures	N/A

A.2.5 Emergency first aid procedures

- Eye contact: Flush eyes immediately with large amounts of water for approximately 15 minutes. Hold eye lids away from eyeballs to ensure thorough rinsing. Do not rub eyes. Get medical attention if irritation persists.
- Inhalation: Remove person from source of exposure and move to fresh air. Some people may be sensitive to fiber induced irritation of the respiratory tract. If symptoms such as shortness of breath, coughing, wheezing, or chest pain develop, seek medical attention. If person experiences continued breathing difficulties, administer oxygen until medical assistance can be rendered.
- Ingestion: Do not induce vomiting. Get medical attention if irritation persists.
- Skin contact: Do not rub or scratch exposed skin. Wash area of contact thoroughly with soap and water. Using a skin cream or lotion after washing may be helpful. Get medical attention if irritation persists.

A.2.6 Reactivity data

Stability/conditions to avoid	Stable under normal conditions of use.
Hazardous polymerization/conditions to avoid	N/A
Hazardous decomposition products	N/A

A.2.7 Spill or leak procedures

Steps to be taken if material is released or spilled

Where possible, use vacuum suction with HEPA filters to clean up spilled material. Use dust suppressant where sweeping if necessary. Avoid clean up procedure which may result in water pollution. (Otherwise, observe [Special protection information](#)).

Waste disposal methods

The transportation, treatment, and disposal of this waste material must be conducted in compliance with all applicable federal, state, and local regulations.

A.2.8 Special protection information

Respiratory protection

Use NIOSH or MSHA approved equipment when airborne exposure limits may be exceeded. NIOSH/MSHA approved breathing equipment may be required for non-routine and emergency use. (See [Special precautions](#) for suitable equipment).

Pending the results of long term health effects studies, engineering control of airborne filters to the lowest level attainable is advised.

Ventilation

Ventilation should be used whenever possible to control or reduce airborne concentrations of fiber and dust. Carbon monoxide, carbon dioxide, oxides of nitrogen, reactive hydrocarbons, and a small amount of formaldehyde may accompany binder burn off during first heat. Use adequate ventilation or other precautions to eliminate vapors resulting from binder burn off. Exposure to burn off fumes may cause respiratory tract irritation, bronchial hyper-reactivity, and asthmatic response.

Skin protection

Wear gloves, hats, and full body clothing to prevent skin contact. Use separate lockers for work clothes to prevent fiber transfer to street clothes. Wash work clothes separately from other clothing and rinse washing machine thoroughly after each use.

Eye protection

Wear safety glasses or chemical worker's goggles to prevent eye contact. Do not wear contact lenses when working with this substance. Have eye baths readily available when eye contact can occur.

A.2.9 Special precautions

Observe general cleanliness.

The toxicology data indicate that ceramic fiber should be handled with caution. Follow the handling practices described in this MSDS strictly. In particular, when handling refractory

ceramic fiber in any application, take special caution to avoid unnecessary cutting and tearing of the material to minimize generation of airborne dust.

It is recommended that you wear full body clothing to reduce the potential for skin irritation. Use washable or disposable clothing. Do not take unwashed work clothing home. Wash work clothes separately from other clothing. Rinse washing machine thoroughly after use. If clothing is to be laundered by someone else, inform launderer of proper procedure. Keep work clothes and street clothes separate to prevent contamination.

Product which has been in service at elevated temperatures (greater than 1800 °F [982 °C]) may undergo partial conversion to cristobalite, a form of crystalline silica. This reaction occurs at the furnace lining hot face. As a consequence, this material becomes more friable; take special caution to minimize generation of air-borne dust. The amount of cristobalite present depends on the temperature and length in service.

IARC has recently reviewed the animal, human, and other relevant experimental data on silica in order to critically evaluate and classify the cancer causing potential. Based on its review, IARC classified crystalline silica as a group 2A carcinogen (probable human carcinogen).

The Occupational Safety and Health Administration (OSHA) permissible exposure limit (PEL) for cristobalite is 0.05 mg/m³ (respirable dust). The ACGIH threshold limit value (TLV) for cristobalite is 0.05 mg/m³ (respirable dust) (ACGIH 1991-92). Use NIOSH or MSHA approved equipment when airborne exposure limits may be exceeded. The minimum respiratory protection recommended for given airborne filter or cristobalite concentrations are:

Table A-2: Concentration

Concentration	Personal protective equipment
0-1 fiber/cc or 0-0.05 mg/m ³ cristobalite (the OSHA PEL)	Optional disposable dust respirator (e.g., 3M 9970 or equivalent)
Up to 5 fibers/cc or up to 10 times the OSHA PEL for cristobalite	Half face, air purifying respirator equipped with high efficiency particulate air (HEPA) filter cartridges (e.g., 3M 6000 series with 2040 filter or equivalent).
Up to 25 fibers/cc or 50 times the OSHA PEL for cristobalite (2.5 mg/m ³)	Full face, air purifying respirator with high particulate efficiency particulate air (HEPA) filter cartridges (e.g., 3M 7800S with 7255 filters or equivalent) or powered air purifying respirator (PARR) equipped with HEPA filter cartridges (e.g., 3M W32655 with W3267 filters or equivalent).
Greater than 25 fibers/cc or 50 times the OSHA PEL for cristobalite (2.5 mg/m ³).	Full face, positive pressure supplied air respirator (e.g., 3M 7800S with W9435 hose & W3196 low pressure regulator kit connected to clean air supply or equivalent).

If airborne fiber or cristobalite concentrations are not known, as minimum protection, use NIOSH/MSHA approved half face, air purifying respirator with HEPA filter cartridges.

Spray insulation surface lightly with water before removal to suppress airborne dust. As water evaporates during removal, spray additional water on surfaces as needed. Only spray enough water to suppress dust so that water does not run onto the floor of the work area. To aid the wetting process, use a surfactant.

After RCF removal is completed, use dust suppressing cleaning methods, such as wet sweeping or vacuuming, to clean the work area. If using dry vacuuming, the vacuum must be equipped with HEPA filter. Do not use air blowing or dry sweeping. Use dust suppressing components to clean up light dust.

Product packaging may contain product residue. Do not reuse except to re-ship or return ceramic fiber products to the factory.

A.3 General precautions for handling and storing high pressure gas cylinders

Edited from several paragraphs of the Compressed Gas Association's *Handbook of Compressed Gases* published in 1981.

Compressed Gas Association
1235 Jefferson Davis Highway
Arlington, VA 22202

Used by permission.

1. Never drop cylinders or permit them to strike each other violently.
2. You may store cylinders in the open, but in such cases, protect them against extremes of weather and, to prevent rusting, from the dampness of the ground. Store cylinders in the shade when located in areas where extreme temperatures are prevalent.
3. Leave the valve protection cap on each cylinder until it has been secured against a wall or bench or placed in a cylinder stand and is ready to be used.
4. Avoid dragging, rolling, or sliding cylinders, even for short distance; move them with a suitable handtruck.
5. Never tamper with safety devices in valves or cylinders.
6. Do not store full and empty cylinders together. Serious suckback can occur when an empty cylinder is attached to a pressurized system.
7. Do not subject any part of the cylinder to a temperature higher than 125 °F (52 °C). Never permit a flame to come in contact with any part of a compressed gas cylinder.
8. Do not place cylinders where they may become part of an electric circuit. When electric arc welding, take precautions to prevent striking an arc against the cylinder.

B Product certifications

A copy of the Declaration of Conformity can be found at the end of the Quick Start Guide.
The most recent Declaration of Conformity can be found at [Emerson.com/Rosemount](https://emerson.com/rosemount).

C SPA with HART® alarm

C.1 Overview

This section describes the SPA with HART® alarm option for the Rosemount OCX8800.

C.2 Description

The Moore Industries SPA with HART® Alarm, [Figure C-1](#), is a four-wire (line or mains powered), site-programmable, digital process alarm.

It connects to a standard HART field device and provides up to four, fully configurable, contact-closure outputs based on readings of the HART digital data. The four Rosemount OCX8800 alarm outputs recognized by the SPA are Low O₂, High CO_e, Calibration Status, and OCX Unit Failure.

Figure C-1: SPA with HART Alarm

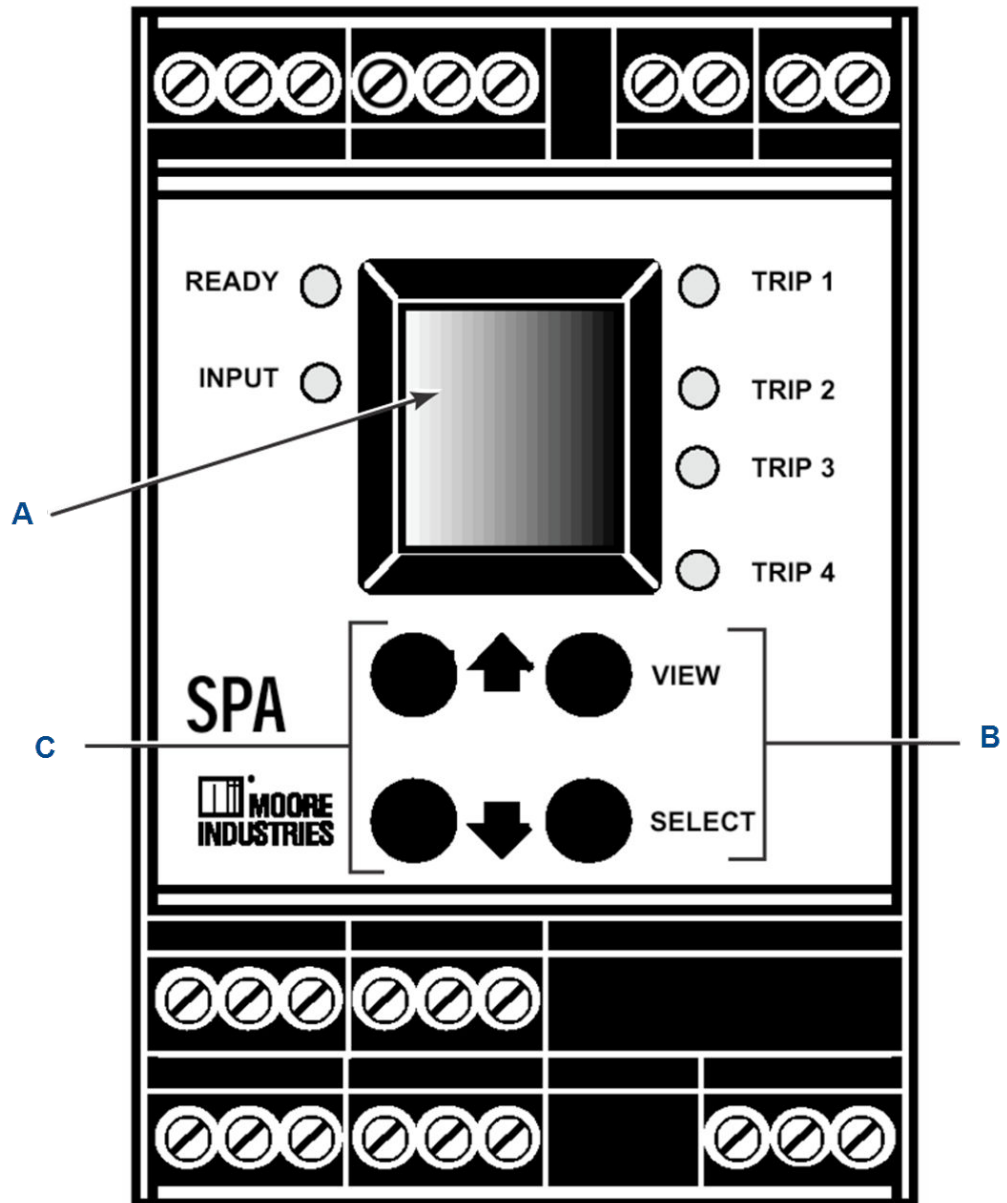

- A. SPA display window
- B. Right-hand buttons
- C. Left-hand buttons

Figure C-2: Rosemount OCX8800 and SPA Interface Connections

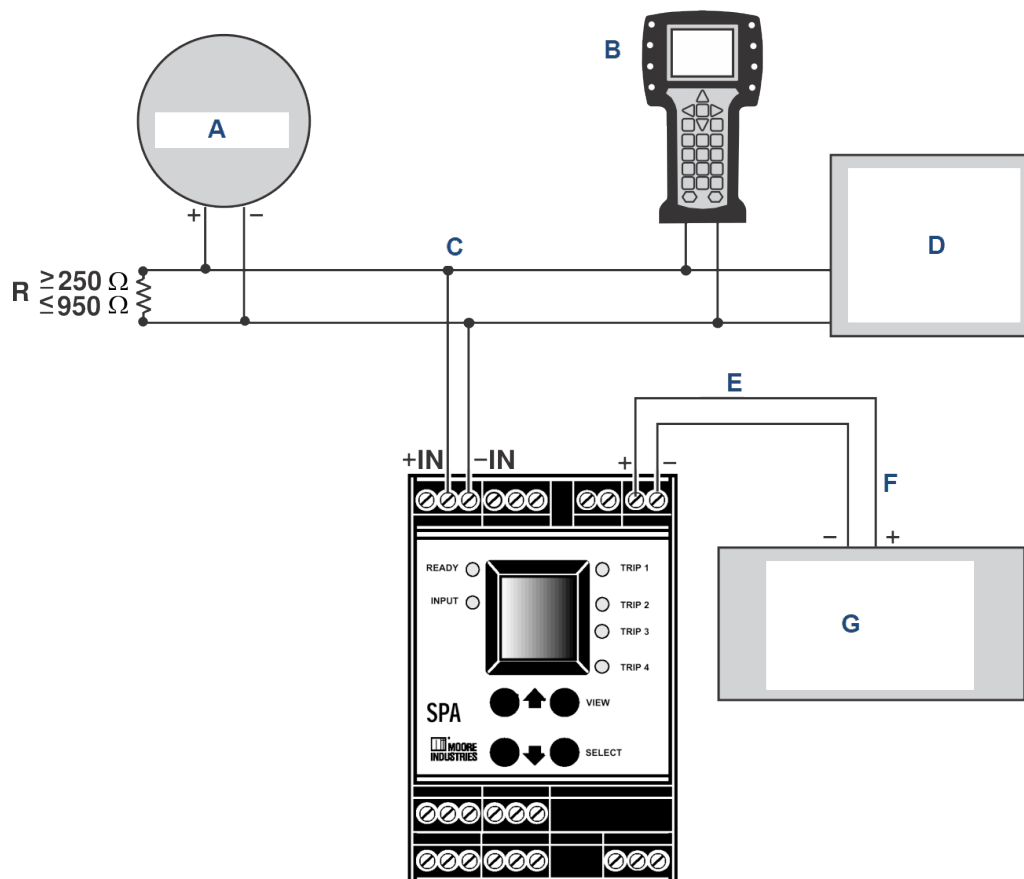

- A. Rosemount OCX8800
- B. Field Communicator
- C. 4-20 mA O₂ signal loop
- D. Customers DCS, PLC, or PC with AMS software
- E. Analog output
- F. 4-20 mA or 0-24 Vdc
- G. Event recorder, audible alarm, or other analog device

C.3 Install

Refer to [Figure C-2](#) for the typical interface connections for the Rosemount OCX8800 and the SPA with HART® alarm.

Refer to the Moore Industries SPA user manual for additional information concerning SPA installation, setup, and operation.

C.4 Setup

To set up the SPA for communication with the transmitter, set internal jumpers and dip switches and configure the SPA operating parameters via a menu-driven selection and calibration procedure.

C.4.1 Jumper and switch settings

If the SPA with HART® was factory-configured by Emerson for operation with your transmitter, jumper and switch setting adjustments are not required. However, you may use the following procedure to verify that the jumper and switch settings are correct. Adjust or verify jumper and switch settings as follows:

SPA jumper and switch settings are shown in [Figure C-3](#).

⚠ CAUTION

Equipment damage

Protect the SPA from electrostatic discharge (ESD) to avoid damage to the SPA electronic circuits.

Procedure

1. Refer to [Figure C-3](#). Turn the SPA over and slide the access cover out.

Figure C-3: SPA Jumper and Dip Switch Settings

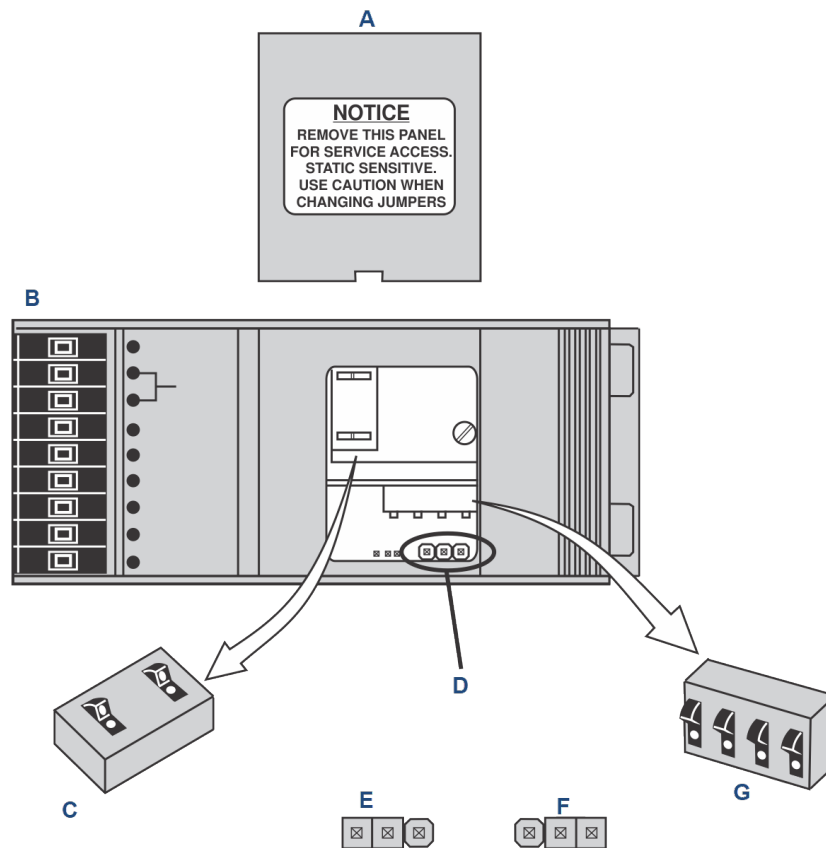

- A. Access cover
- B. SPA - bottom view
- C. Source current Dip switches (shown in correct position)
- D. Password jumper pins
- E. Password on
- F. Password off
- G. Failsafe Dip switches (shown in correct position)

2. Verify that the Password jumper is set to the **Off** position. If the jumper is in the **On** position, reposition the jumper.
3. Check the position of the failsafe Dip switches. Position the Dip switches as shown in [Figure C-3](#).
4. Check the position of the source current Dip switches. Position the Dip switches as shown in [Figure C-3](#).
5. Reinstall the SPA access cover.

C.4.2 Configure/calibrate

Prior to operation, use the menu-driven setup procedure to configure the SPA operating parameters. At the end of the configuration procedure, the SPA analog output signal is calibrated to ensure valid communications.

Figure C-4: SPA Setup for Calibration

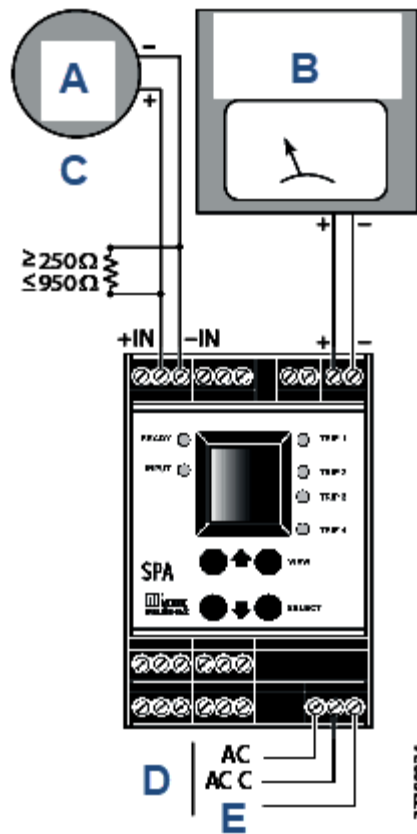

- A. Rosemount OCX8800
- B. Fluke Model 87 multimeter or equivalent
- C. Optional
- D. AC or DC power input
- E. Ground

Procedure

1. See [Figure C-4](#). Connect a calibrated ammeter (Fluke Model 87 or equivalent, accurate to $\pm 0.025\%$) to the SPA analog output terminals. Observe polarity.
2. Connect a 90 to 260 Vac or 22 to 300 Vdc power source to the SPA power terminals. When connecting an AC power source, use the AC and ACC (AC Common) terminals. For a DC source, use the AC and ground terminals.
3. If desired, connect the 4 to 20 mA O₂ signal wires from the transmitter analog output terminal block to the SPA input terminals.

The Rosemount OCX8800 must be operational to transmit the O₂ signal. Observe polarity.

Note

The O₂ signal is not required for SPA configuration or calibration. The Rosemount OCX8800 interface will allow you to observe the O₂ signal level when the SPA configuration procedure is completed.

Observe the front panel of the SPA, [Figure C-1](#):

- a. A process value display in the SPA window indicates that the SPA is operational. Four buttons are located below the display window.
 - b. Press **Left** to scroll up or down through the SPA command menu, a submenu, or parameter values list.
 - c. Press **VIEW** to display rail limits and alarm relay configurations. There are five sequential displays in VIEW mode. While in VIEW mode, the **Up**, **Down**, and **SELECT** buttons are disabled.
-

Note

In VIEW mode, you can scroll through and display the output zero and full scale settings and the alarm relay trip points and configurations.

- d. Press **SELECT** to select the displayed menu or submenu command or select a displayed parameter variable.
4. [Figure C-5](#) shows the SPA menu, submenu, and parameter values that must be selected to configure the SPA for use with the transmitter. Use the following instructions and selections to properly configure the SPA.

Figure C-5: SPA Configuration Menu for Rosemount OCX8800 Communication

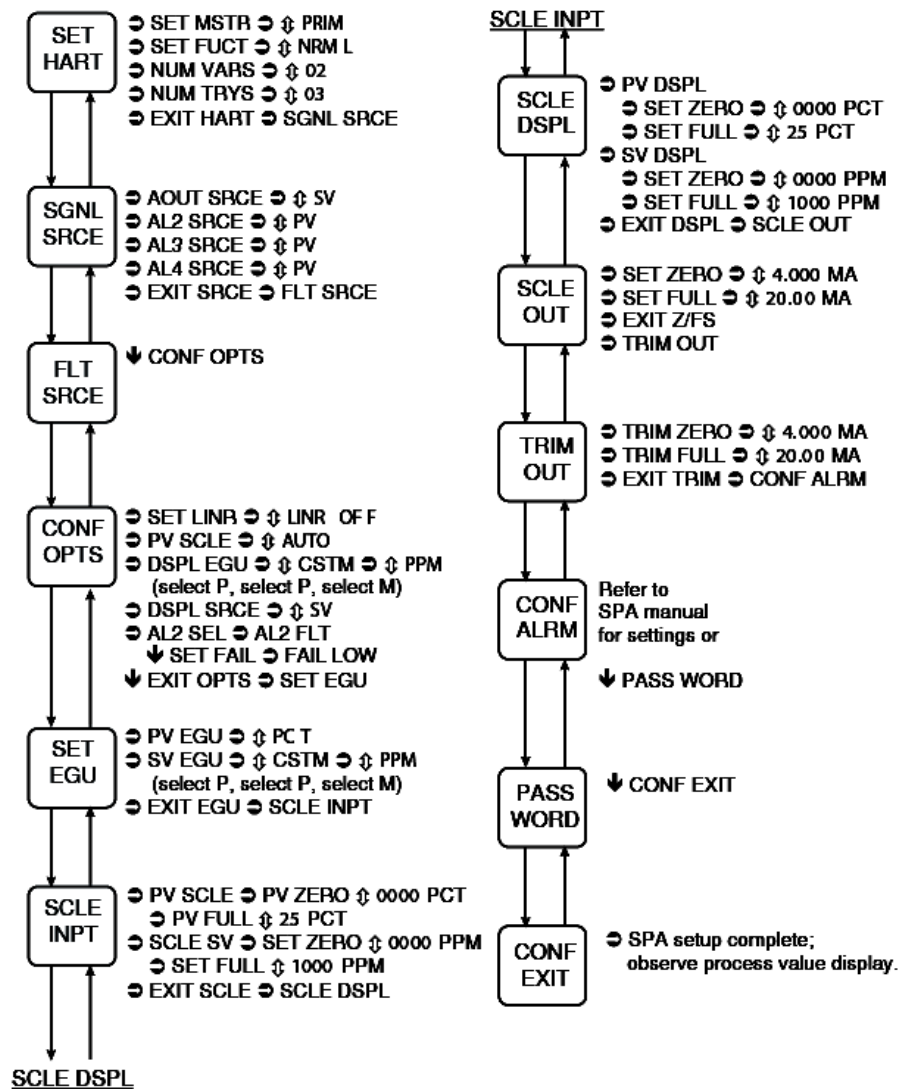

37590003



a) Press **SELECT**.



Observe the display window on the SPA front panel. The display window should read **SET HART**.

See the **SET HART** command in [Figure C-5](#). The **SET HART** submenu and related parameter values that must be selected via the front panel buttons on the SPA are to the right of the command window.

In the submenu views shown:

- ↓ means press **down**.
- ↑ means press **up**.
- ⊙ means press **SELECT** one time.

 means press  or  until the desired parameter value is shown in the SPA window.

- b) Proceed through the SPA menu, selecting the menu commands and parameter values as indicated.
- c) After completing the sequence in the first column, go to the top of the second column and continue.
- d) To exit the menu, repeatedly press **SELECT** to display any main menu command. Then press  or  until **CONF EXIT** is displayed. Select **CONF EXIT**.

The SPA user manual provides detailed instructions concerning the configuration menu and the submenu structure for each main command.

D Returning material

To expedite the return process outside of the United States, contact the nearest Rosemount representative.

Within the United States, call the Emerson Instrument and Valves Response Center using the 1-800-654-RSMT (7768) toll-free number. This center, available 24 hours a day, will assist you with any needed information or materials.

The center will ask for product identification, reason for return, and will provide a Return Material Authorization (RMA) number. The center will also ask for the process material to which the product was last exposed.

For more information: [Emerson.com](https://www.emerson.com)

©2023 Emerson. All rights reserved.

Emerson Terms and Conditions of Sale are available upon request. The Emerson logo is a trademark and service mark of Emerson Electric Co. Rosemount is a mark of one of the Emerson family of companies. All other marks are the property of their respective owners.

ROSEMOUNT™

