

# Rosemount™ 975 Flame Detector

HART® Communication Manual



Legend

# Contents

## Section 1: Introduction

1.1 Using this manual .....	1
1.2 Product recycling/disposal .....	1
1.3 Scope .....	1
1.4 Purpose .....	1
1.5 Reference documents .....	1

## Section 2: Product Overview

2.1 Rosemount 975 Flame Detector Product Overview .....	3
---	---

## Section 3: HART Interconnection

3.1 Overview .....	5
3.2 Point-to-point mode .....	5
3.3 Multidrop mode .....	5

## Section 4: HART Device Description Language

4.1 Overview .....	7
4.2 HART protocol .....	7

## Section 5: HART Menu Structure

5.1 HART menu overview .....	9
5.2 Root menu .....	10
5.3 Status menu .....	11
5.4 Device setup menu .....	12
5.5 HART output menu .....	13
5.6 HART status menu .....	14

## Appendix A: Field Device Status

A.1 Field Device Status Description .....	15
---	----

Legacy

# Section 1 Introduction

## 1.1 Using this manual

The sections in this manual provide information on installing, operating, and maintaining the Rosemount™ 975 Flame Detector. The sections are organized as follows:

[Section 2: Product Overview](#) provides a high-level description of the Rosemount 975 Flame Detector.

[Section 3: HART Interconnection](#) contains information on the connection modes used to connect HART Communication with the Rosemount 975 Flame Detector.

[Section 4: HART Device Description Language](#) describes the HART Device Description Language format used to configure the Rosemount 975 Flame Detector.

[Section 5: HART Menu Structure](#) provides HART menu, submenu, and command information.

[Appendix A: Field Device Status](#) contains field device status information.

## 1.2 Product recycling/disposal

Recycling of equipment and packaging should be taken into consideration and disposed of in accordance with local and national legislation/regulations.

## 1.3 Scope

Digital communication with the Rosemount 975 Flame Detector allows the operator to monitor the status of the detector, determine factory settings and initiate field tests.

This document provides guidance for establishing HART communication and describe the HART menu structure when using the Rosemount 975 Flame Detector with a HART Handheld Communicator, computer, or another process interface device that supports Device Description Language (DDL).

## 1.4 Purpose

This manual is designed for use by system integrators and end users to compliment other documentation (for example, the user manual for your Rosemount 975 Flame Detector) by providing a complete, unambiguous description of the HART Host Application and Communication.

## 1.5 Reference documents

*HART Field Communications Protocol Specification, HCF\_SPEC-12, Available from the HCF.*

Legacy

---

## Section 2 Product Overview

---

---

Rosemount 975 Flame Detector Product Overview ..... page 3

---

### 2.1 Rosemount 975 Flame Detector Product Overview

The Rosemount 975 Series Flame Detectors are a family of Flame Detectors that incorporate advanced optical spectral analysis of flames. Rosemount 975 Flame Detectors operate reliably in the harsh conditions of offshore drilling and production platforms, FPSO vessels, fuel loading facilities, LNG and LPG plants, oil refineries, aircraft hangars, paint spray booths, gas turbine power stations, chemical and petrochemical plants.

Rosemount 975 Flame Detectors employ the latest UV/IR (Ultra Violet & Infrared), and IR3 (Triple IR patented multi-spectrum detection) Flame Detection technologies.

Depending on the specific model, the Rosemount 975 Flame Detector may include the following interfaces: 4-20mA current output, HART communication, relays, RS485 ModBus communication, status LEDs.

Legacy



## Section 3 HART Interconnection

---

Overview .....	page 5
Point-to-point mode .....	page 5
Multidrop mode .....	page 5

---

### 3.1 Overview

The host connects to the Rosemount 975 Flame Detector through the two-wire 4-to-20mA current loop. Refer to the User Manual for your Rosemount 975 Flame Detector for connection details.

This is the only output from the Rosemount 975 Flame Detector, representing the "Fire Detection" channel. This output corresponds to the Primary Variable (PV). HART Communication is supported on this loop.

### 3.2 Point-to-point mode

The HART Communicator can connect to Rosemount 975 Flame Detector at any wiring termination point in the analog output signal loop. Connect the HART communicator in parallel with 500 Ohm load resistor. The HART connections are non-polarized.

Turn on the HART Communicator. If a device is found, the HART Communicator displays the Main Menu. If no device is found, check the connections and verify the presence of a 500 ohms load resistance in series in the loop.

### 3.3 Multidrop mode

Optical flame detectors are life safety devices and require the 4-20 mA loop for transmitting important detector status data. They should not be used in conjunction with multidrop mode. If multidrop mode required, the alarm and fault relay contacts must be connected directly to the safety system or fire panel for signaling purposes.

**Figure 3-1. HART Connection Block Diagram**

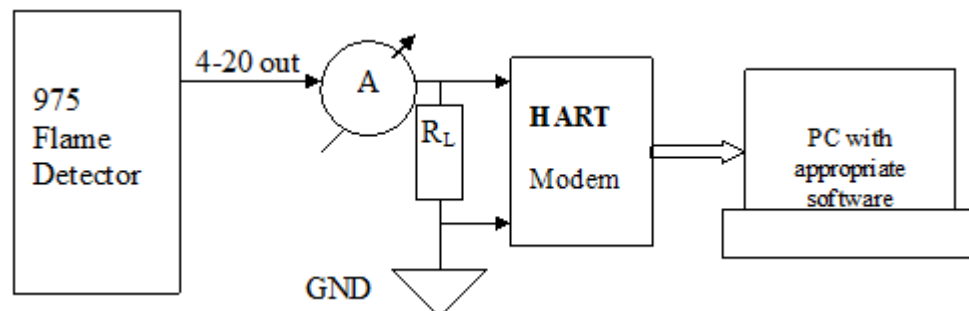

Legacy

---

# Section 4 HART Device Description Language

---

---

Overview .....	page 7
HART protocol .....	page 7

---

## 4.1 Overview

This section contains information on the HART Device Description Language (DDL) format used to configure the Rosemount 975 Flame Detector.

## 4.2 HART protocol

The HART protocol incorporates a concept called the Device Description Language that enables all suppliers of HART instruments to define and document their products in a single consistent format. This format is readable by handheld communicators, computers, and other process interface devices, regardless of manufacturer, providing full functionality from any HART device.

---

### Note

For full compliance with the HART Host application, install a Rosemount 975 Flame Detector Device Description on your computer.

---

The Rosemount 975 Flame Detector Device Description enables presenting the HART menu in a graphical mode. This option is not supported by all hosts manufacturers. Refer to the HART host literature for information about using the graphical mode.

Legacy

# Section 5 HART Menu Structure

HART menu overview .....	page 9
Root menu .....	page 10
Status menu .....	page 11
Device setup menu .....	page 12
HART output menu .....	page 13
HART status menu .....	page 14

## 5.1 HART menu overview

The following figure shows the HART menu structure. The editable menu options are bolded. The submenus are underlined.

Figure 5-1. HART Menu Structure

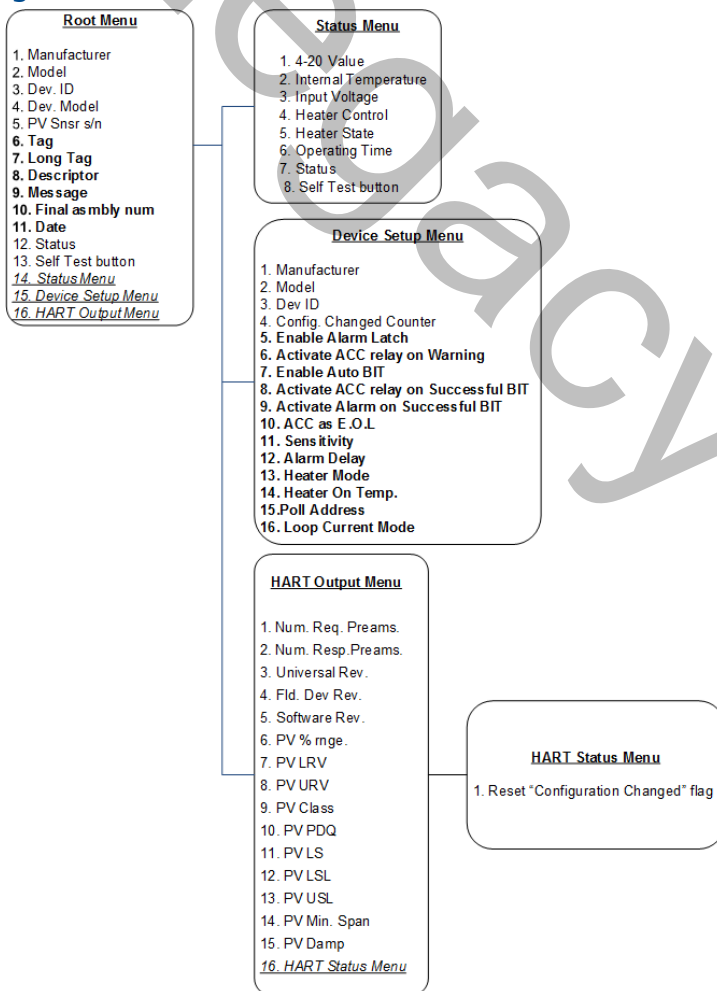

## 5.2 Root menu

When HART communication is established with the Rosemount 975 Flame Detector, the *Root* menu opens.

Figure 5-2. Root Menu



Table 5-1. Root Menu Commands

1	Manufacturer	Rosemount, Inc.	Read
2	Model	975	Read
3	Dev ID	Device unique identification number	Read
4	Dev. Model	Device sensor type (see Annex B, Table B1: Fire Detection Sensor Type Codes)	Read
5	PV Snsr s/n	Device serial number	Read
6	Tag	User-definable text up to 16 characters in length associated with the field device installation.	R/W
7	Long Tag	User-definable text up to 32 characters in length associated with the field device installation.	R/W
8	Descriptor	User-definable text associated with the field device.	R/W
9	Message	User-definable text associated with the field device.	R/W
10	Final assembly num	A number associated with the field device used for identification purposes.	R/W
11	Date	A user-definable date.	R/W
12	Status	Indicates a field device condition. Refer to <a href="#">Appendix A: Field Device Status</a> .	Read
13	Self Test	Performs internal tests. Detected problems are displayed in the <i>Status</i> menu.	Button
14	<i>Status</i> menu	Displays current status and diagnostic information.	Menu
15	<i>Device Setup</i> menu	Setup and configuration functions	Menu
16	HART Output menu	HART-specific variables	Menu

## 5.3 Status menu

Figure 5-3. Status Menu

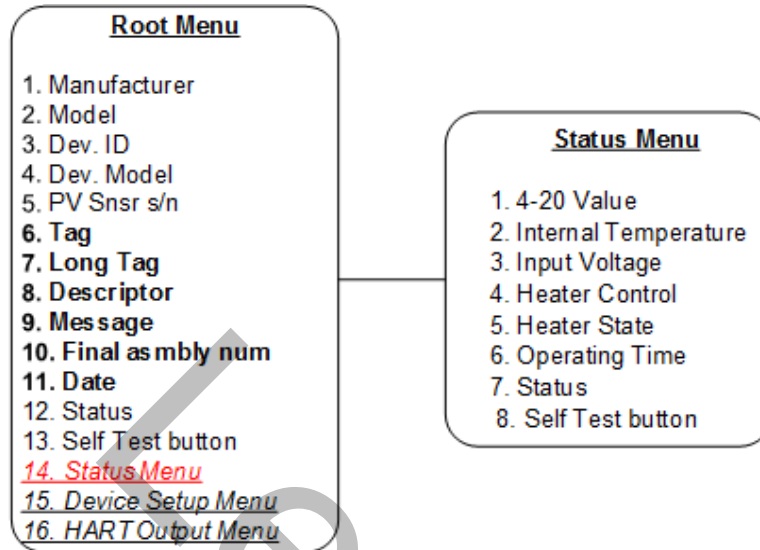

Table 5-2. Status Menu Commands

1	4-20 Value	Displays the analog output of the Fire Detection Channel.	Read
2	Internal Temperature	Displays the internal temperature of the Rosemount 975 Flame Detector in degrees Celsius.	Read
3	Input Voltage	Displays the Rosemount 975 Flame Detector's supply voltage.	Read
4	Heater Control	Indicates whether the heater control is Manual or Automatic.	Read
5	Heater State	Indicates whether the heater is On or Off.	Read
6	Operating Time	Displays the Rosemount 975 Flame Detector's total operating time since the last startup.	Read
7	Status	Indicates a field device condition. Refer to <a href="#">Appendix A: Field Device Status</a> .	Read
8	Self Test	Performs internal tests. Detected problems are displayed in the <i>Status</i> menu.	Button

## 5.4 Device setup menu

Figure 5-4. Device Setup Menu

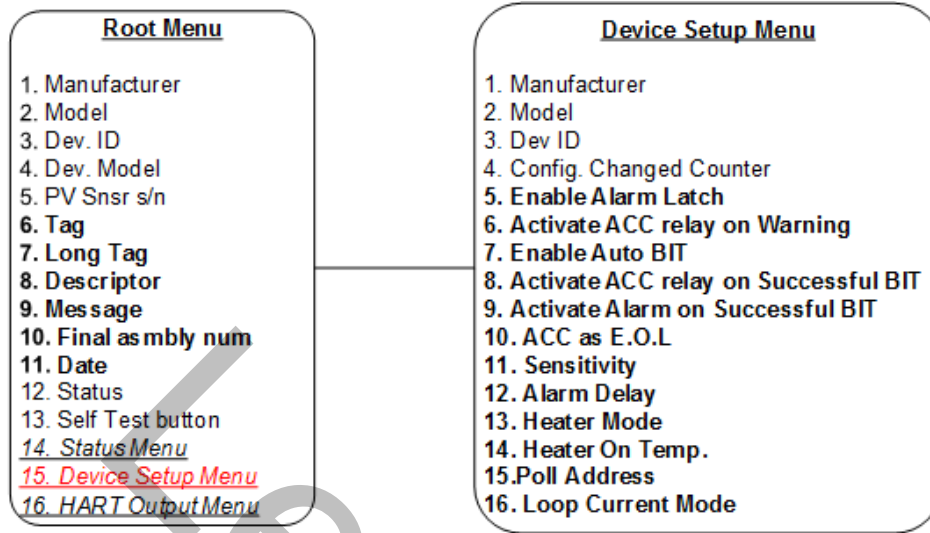

Table 5-3. Device Setup Menu Commands

1	Manufacturer	Rosemount, Inc.	Read
2	Model	975	Read
3	Dev ID	Device unique identification number	Read
4	Config. Changed Counter	The number of Device Configuration changes since the manufacture.	Read
5	Enable Alarm Latch	Enables the alarm relay to remain energized after exiting the Alarm Mode.	Read
6	Activate ACC relay on Warning	Activates ACC relay during Warning status.	R/W
7	Enable Auto BIT	Activates alarm after successful self-test.	R/W
8	Activate ACC relay on Successful BIT	Activates ACC Relay after successful self-test.	R/W
9	Activate Alarm on Successful BIT	Activates Alarm after successful self test.	R/W
10	ACC as E.O.L	Accessory Relay is activated at Power on Continuously.	R/W
11	Sensitivity	Detectors Sensitivity setting	R/W
12	Alarm Delay	Defines the delay between Fire Detection and Alarm.	R/W
13	Heater Mode	Select a Heater Mode: <b>Auto</b> , <b>On</b> , or <b>Off</b> .	R/W
14	Heater on Temp.	This option is active in Heater <b>Auto</b> mode. It allows setting the temperature at which the optics heater begins operating.	R/W
15	Poll Address	The address used by the host to identify a field device.	R/W
16	Loop Current Mode	Select a Current Mode: <b>Fixed</b> or <b>Not Fixed</b> .	R/W



## 5.5 HART output menu

Figure 5-5. HART Output Menu

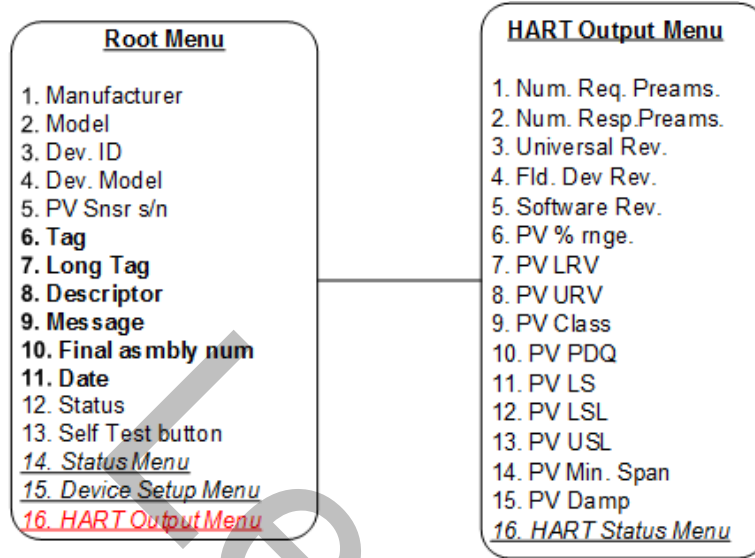

Table 5-4. HART Output Menu

1	Num. Req. Preams.	HART-specific synchronization messages.	Read
2	Num. Resp. Preams.	HART-specific synchronization messages.	Read
3	Universal Rev.	HART protocol revision	Read
4	Fld. Dev Rev.	The Field Device hardware revision.	Read
5	Software Rev.	The Field Device software revision.	Read
6	PV % rng.	The Primary Variable (PV) Percent of Range tracks the Digital Value representation with respect to the range defined by the Lower Range and Upper Range Value for normal operating modes. The units of this variable are expressed as a percentage.	Read
7	PV LRV	PV Lower Range Value	Read
8	PV URV	PV Upper Range Value	Read
9	PV Class	Not classified	Read
10	PV PDQ	Indicates the PV status.	Read
11	PV LS	Indicates whether the PV is limited.	Read
12	PV LSL	Lower Range Value Good status	Read
13	PV USL	Upper Range Value Good status	Read
14	PV Min Span	PV Upper Range Value–PV Lower Range Value	Read
15	PV Damp.	The time required to change the PV value.	Read

## 5.6 HART status menu

Figure 5-6. HART Status Menu

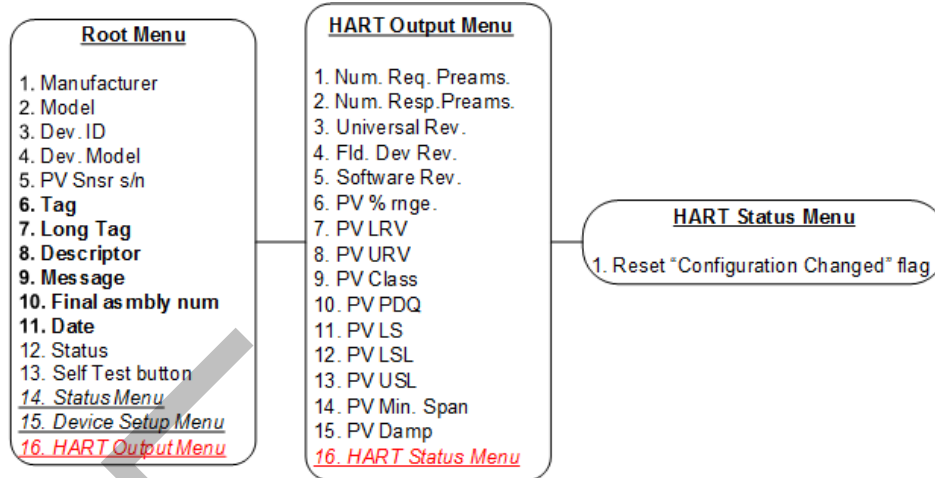

Table 5-5. HART Status Menu

1	Reset the Configuration Changed flag	Clears the Configuration Changed bit	Button
---	--------------------------------------	--------------------------------------	--------

# Appendix A Field Device Status

Field Device Status Description ..... page 15

## A.1 Field Device Status Description

The following table contains the Rosemount 975 Flame Detector field device statuses and a description of each status.

**Table A-1. Field Device Status Description**

Field Device Status	Description
N	Normal State
B	Self-test is performed
BIT FAULT	Self-test failed
IR	Infrared Detection
UV	Ultraviolet Detection
W	Fire Warning
A	Fire Alarm
F	General Fault

Legacy

Legend

## Global Headquarters

### Emerson Automation Solutions

6021 Innovation Blvd.  
Shakopee, MN 55379, USA  
+1 800 999 9307 or +1 952 906 8888  
+1 952 949 7001  
RFQ.RMD-RCC@Emerson.com

## North America Regional Office

### Emerson Automation Solutions

8200 Market Blvd.  
Chanhassen, MN 55317, USA  
+1 800 999 9307 or +1 952 906 8888  
+1 952 949 7001  
RMT-NA.RCCRFQ@Emerson.com

## Latin America Regional Office

### Emerson Automation Solutions

1300 Concord Terrace, Suite 400  
Sunrise, FL 33323, USA  
+1 954 846 5030  
+1 954 846 5121  
RFQ.RMD-RCC@Emerson.com

## Europe Regional Office

### Emerson Automation Solutions Europe GmbH

Neuhofstrasse 19a P.O. Box 1046  
CH 6340 Baar  
Switzerland  
+41 (0) 41 768 6111  
+41 (0) 41 768 6300  
RFQ.RMD-RCC@Emerson.com

## Asia Pacific Regional Office

### Emerson Automation Solutions Asia Pacific Pte Ltd

1 Pandan Crescent  
Singapore 128461  
+65 6777 8211  
+65 6777 0947  
Enquiries@AP.Emerson.com

## Middle East and Africa Regional Office

### Emerson Automation Solutions

Emerson FZE P.O. Box 17033  
Jebel Ali Free Zone - South 2  
Dubai, United Arab Emirates  
+971 4 8118100  
+971 4 8865465  
RFQ.RMTMEA@Emerson.com

 [Linkedin.com/company/Emerson-Automation-Solutions](https://www.linkedin.com/company/Emerson-Automation-Solutions)

 [Twitter.com/Rosemount\\_News](https://twitter.com/Rosemount_News)

 [Facebook.com/Rosemount](https://www.facebook.com/Rosemount)

 [Youtube.com/user/RosemountMeasurement](https://www.youtube.com/user/RosemountMeasurement)

 [Google.com/+RosemountMeasurement](https://www.google.com/+RosemountMeasurement)

Standard Terms and Conditions of Sale can be found on the [Terms and Conditions of Sale page](#).

The Emerson logo is a trademark and service mark of Emerson Electric Co.  
Rosemount and Rosemount logotype are trademarks of Emerson.  
All other marks are the property of their respective owners.  
© 2017 Emerson. All rights reserved.