

Rosemount™ 2410 Tank Hub



NOTICE

Read this manual before working with the product. For personal and system safety and for optimum product performance, ensure that you thoroughly understand the contents before installing, using, or maintaining this product.

For equipment service or support needs, contact your local Emerson representative.

Spare Parts

Any substitution of non-recognized spare parts may jeopardize safety. Repair, e.g. substitution of components etc, may also jeopardize safety and is under no circumstances allowed.

Rosemount Tank Radar AB will not take any responsibility for faults, accidents, etc caused by non-recognized spare parts or any repair which is not made by Rosemount Tank Radar AB.

NOTICE

The products described in this document are NOT designed for nuclear-qualified applications. Using non-nuclear qualified products in applications that require nuclear-qualified hardware or products may cause inaccurate readings. For information on Rosemount nuclear-qualified products, contact your local Emerson Sales Representative.

⚠ WARNING

WARNING - Substitution of components may impair Intrinsic Safety.

WARNING - To prevent ignition of flammable or combustible atmospheres, disconnect power before servicing.

AVERTISSEMENT - La substitution de composants peut compromettre la sécurité intrinsèque.

AVERTISSEMENT - Ne pas ouvrir en cas de présence d'atmosphère explosive.

Contents

Chapter 1	Introduction.....	5
	1.1 Safety messages.....	5
	1.2 Symbols.....	6
	1.3 Manual overview.....	7
	1.4 Technical documentation.....	8
	1.5 Service support.....	10
	1.6 Product certifications.....	10
	1.7 Product recycling/disposal.....	10
	1.8 Packing material.....	10
Chapter 2	Overview.....	11
	2.1 Introduction.....	11
	2.2 Communication.....	14
	2.3 Components.....	16
	2.4 System overview.....	17
	2.5 Installation procedure.....	24
Chapter 3	Installation.....	25
	3.1 Safety messages.....	25
	3.2 Installation considerations.....	25
	3.3 Mechanical installation.....	27
	3.4 Electrical installation.....	30
Chapter 4	Configuration.....	63
	4.1 Safety messages.....	63
	4.2 Introduction.....	63
	4.3 Configuration tools.....	64
	4.4 Basic configuration of a Rosemount 2410 Tank Hub.....	65
	4.5 Advanced configuration.....	66
	4.6 Configuration using TankMaster WinSetup.....	66
Chapter 5	Operation.....	69
	5.1 Safety messages.....	69
	5.2 Integral display.....	69
	5.3 Start-up information.....	71
	5.4 Error codes.....	72
	5.5 LED.....	74
	5.6 Specifying display variables.....	77
Chapter 6	Service and troubleshooting.....	79
	6.1 Safety messages.....	79
	6.2 Service.....	80
	6.3 Troubleshooting.....	97
Appendix A	Specifications and reference data.....	109
	A.1 General specifications.....	109

	A.2 Communication/display/configuration specifications.....	111
	A.3 Electrical specifications.....	121
	A.4 Mechanical specifications.....	124
	A.5 Environmental specifications.....	125
	A.6 Dimensional drawings.....	125
	A.7 Ordering information.....	127
Appendix B	Advanced configuration.....	139
	B.1 Safety messages.....	139
	B.2 Extended configuration options in WinSetup.....	140
	B.3 Change the communication parameters for the primary bus.....	140
	B.4 Open the secondary bus window.....	141
	B.5 Configure a virtual relay output.....	142
	B.6 Set up a Rosemount 2410 for hybrid density applications.....	146
	B.7 Volume configuration.....	150
	B.8 Arithmetic operations.....	154
	B.9 Configure the analog output.....	157
	B.10 Configuration of analog input / HART [®] slave device.....	160

1 Introduction

1.1 Safety messages

Instructions and procedures in this section may require special precautions to ensure the safety of the personnel performing the operations. Information that potentially raises safety issues is indicated by a warning symbol () . Refer to the following safety messages before performing an operation preceded by this symbol.

WARNING

Failure to follow safe installation and servicing guidelines could result in death or serious injury.

Ensure only qualified personnel perform the installation.

Use the equipment only as specified in this manual. Failure to do so may impair the protection provided by the equipment.

WARNING

Explosions could result in death or serious injury.

Verify that the operating atmosphere of the transmitter is consistent with the appropriate hazardous locations certifications.

Before connecting a handheld communicator in an explosive atmosphere, ensure that the instruments in the loop are installed in accordance with intrinsically safe or non-incendive field wiring practices.

Do not remove the gauge cover in explosive atmospheres when the circuit is alive.

WARNING

Electrical shock could cause death or serious injury.

Use extreme caution when making contact with the leads and terminals.

WARNING

Any substitution of non-recognized parts may jeopardize safety. Repair (e.g. substitution of components) may also jeopardize safety and is not allowed under any circumstances.

WARNING

Physical access





Unauthorized personnel may potentially cause significant damage to and/or misconfiguration of end users' equipment. This could be intentional or unintentional and needs to be protected against.

Physical security is an important part of any security program and fundamental in protecting your system. Restrict physical access by unauthorized personnel to protect end users' assets. This is true for all systems used within the facility.

1.2

Symbols

Table 1-1: Symbols

	<p>The CE marking symbolizes the conformity of the product with the applicable European Community Directives.</p>
	<p>The EU-Type Examination Certificate is a statement of a Notified Certification Body declaring that this product meets the Essential Health and Safety Requirements of the ATEX directive</p>
	<p>The FM APPROVED Mark indicates that the equipment is approved by FM Approvals according to applicable Approval Standards and is applicable for installation in hazardous locations</p>
	<p>Protective Earth</p>
	<p>Ground</p>
<p>85 °C</p>	<p>Use wiring rated for maximum ambient temperature + 15 °C Examples: For connections in ambient temperatures up to 70 °C use wiring rated 85 °C minimum. For connections in ambient temperatures up to 60 °C use wiring rated 75 °C minimum. For connections in ambient temperatures up to 50 °C use wiring rated 65 °C minimum.</p>

1.3 Manual overview

This manual provides information on installation, configuration and maintenance of the Rosemount 2410 Tank Hub.

Chapter [Overview](#) provides a brief description of the various components in a Rosemount Tank Gauging system and recommended installation procedure.

Chapter [Installation](#) covers installation considerations as well as mechanical and electrical installation.

Chapter [Configuration](#) describes how to configure the Rosemount 2410 Tank Hub by using the TankMaster WinSetup configuration program.

Chapter [Operation](#) describes the integral display and how to specify display variables. It also includes start-up information, error messages, and LED functionality

Chapter [Service and troubleshooting](#) covers tools, troubleshooting, and various service instructions.

Appendix [Specifications and reference data](#) contains specifications, dimensional drawings, and ordering table.

Appendix [Advanced configuration](#) describes various advanced configuration options.

1.4 Technical documentation

The Rosemount Tank Gauging System includes a wide portfolio of user documentation. For a complete list, see product pages on [Emerson.com/Rosemount](https://www.emerson.com/Rosemount).

Reference manuals

- Rosemount Tank Gauging System Configuration Manual ([00809-0300-5100](#))
- Rosemount 2460 System Hub ([00809-0100-2460](#))
- Rosemount 2410 Tank Hub ([00809-0100-2410](#))
- Rosemount 5900S Radar Level Gauge ([00809-0100-5900](#))
- Rosemount 5900C Radar Level Gauge ([00809-0100-5901](#))
- Rosemount 2240S Multi-Input Temperature Transmitter ([00809-0100-2240](#))
- Rosemount 2230 Graphical Field Display ([00809-0100-2230](#))
- Rosemount 5300 Guided Wave Radar ([00809-0100-4530](#))
- Rosemount 5408 Radar Level Transmitter ([00809-0300-4408](#))
- Rosemount 3308 Series Wireless Guided Wave Radar ([00809-0100-4308](#))
- Rosemount Tank Gauging Wireless System ([00809-0100-5200](#))
- Rosemount TankMaster Software Installation Manual ([00809-0400-5110](#))
- Rosemount TankMaster WinOpi ([00809-0200-5110](#))
- Rosemount TankMaster WinSetup ([00809-0100-5110](#))
- Rosemount TankMaster WinView ([00809-0300-5110](#))
- Rosemount 5900 Proof Test with Reference Reflector ([00809-0200-5900](#))
- Rosemount TankMaster Floating Roof Monitoring ([00809-0500-5100](#))
- Rosemount TankMaster Full containment tanks ([00809-0500-5110](#))
- Rosemount 5900 Radar Level Gauge and Rosemount 2410 Tank Hub Safety Manual Option S ([00809-0400-5100](#))
- Rosemount 5900 Radar Level Gauge and Rosemount 2410 Tank Hub Safety Manual SIL3 ([00809-0200-5100](#))
- Rosemount TankMaster Mobile User Guide ([00809-0100-5120](#))
- Rosemount TankMaster Mobile Installation Manual ([00809-0200-5120](#))

Product data sheets

- Rosemount Tank Gauging System ([00813-0100-5100](#))
- Rosemount TankMaster Inventory Management Software ([00813-0100-5110](#))
- Rosemount TankMaster Mobile Inventory Management Software ([00813-0100-5120](#))
- Rosemount 2460 System Hub ([00813-0100-2460](#))
- Rosemount 2410 Tank Hub ([00813-0100-2410](#))
- Rosemount 5900S Radar Level Gauge ([00813-0100-5900](#))
- Rosemount 5900C Radar Level Gauge ([00813-0100-5901](#))
- Rosemount 2240S Multi-input Temperature Transmitter ([00813-0100-2240](#))
- Rosemount 565/566/765 Temperature and Water Level Sensors ([00813-0100-5565](#))
- Rosemount 614 Cryogenic Spot Temperature Sensor ([00813-0100-5614](#))
- Rosemount 2230 Graphical Field Display ([00813-0100-2230](#))
- Rosemount 5300 Level Transmitter ([00813-0100-4530](#))
- Rosemount 5408 Level Transmitter ([00813-0100-4408](#))

1.5 Service support

For service support contact the nearest Emerson Automation Solutions /Rosemount Tank Gauging representative. Contact information can be found on the web site www.Emerson.com.

1.6 Product certifications

See the Rosemount 2410 [Product Certifications](#) document for detailed information on the existing approvals and certifications.

1.7 Product recycling/disposal

Recycling of equipment and packaging should be taken into consideration and disposed of in accordance with local and national legislation/regulations.

1.8 Packing material

Rosemount Tank Radar AB is fully certified according to ISO 14001 environmental standards. By recycling the corrugated paperboard, or wooden boxes, used for shipping our products you can contribute to take care of the environment.

Reuse and recycling

Experience has shown that wooden boxes can be used several times for various purposes. After careful disassembly the wooden parts may be reused. Metal waste may be converted.

Energy recovery

Products which have served their time may be divided into wood and metal components and the wood can be used as fuel in sufficient ovens.

Due to its low moisture content (approximately 7%) this fuel has a higher calorific value than ordinary wood fuel (moisture content approximately 20%).

When burning interior plywood the nitrogen in the adhesives may increase emissions of nitrogen oxides to the air 3-4 times more than when burning bark and splinter.

Note

Landfill is not a recycling option and should be avoided.

2 Overview

2.1 Introduction

The Rosemount™ 2410 Tank Hub collects measurement data and status information from field devices designed for the Rosemount Tank Gauging system via the intrinsically safe 2-wire **Tankbus**⁽¹⁾. The Tankbus carries both data transmission and power supply (see also [Tankbus](#)).

Figure 2-1: System Integration

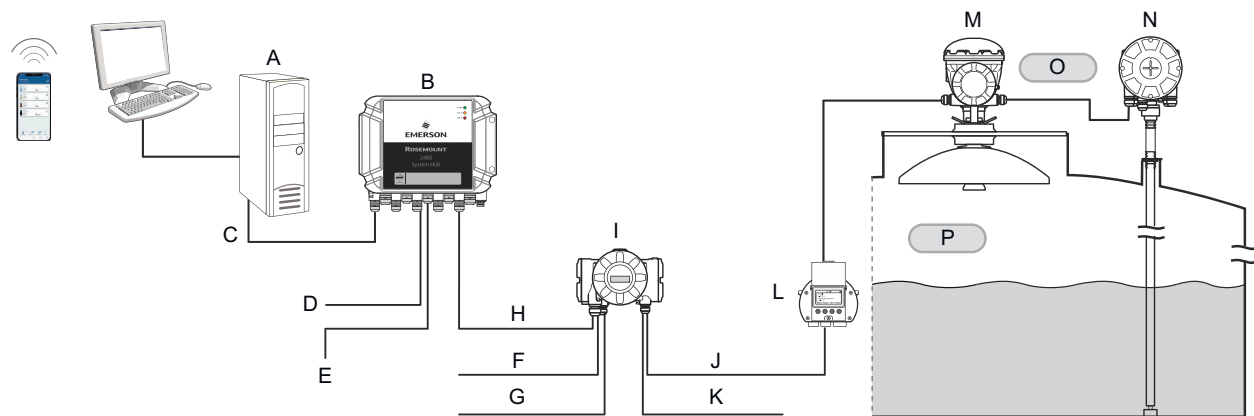

- | | |
|------------------------------|--|
| A. Rosemount TankMaster | I. Rosemount 2410 Tank Hub |
| B. Rosemount 2460 System Hub | J. Tankbus |
| C. Ethernet (Modbus TCP) | K. Secondary bus (IS) |
| D. Host | L. Rosemount 2230 Field Display |
| E. Servo gauges | M. Rosemount 5900S Radar Level Gauge |
| F. Secondary Bus (Non-IS) | N. Rosemount 2240S Temperature Transmitter |
| G. Relay Outputs | O. Zone 1 |
| H. Primary Bus | P. Zone 0 |

(1) The intrinsically safe Tankbus complies with the FISCO FOUNDATION™ Fieldbus standard.

2.1.1 Features

The Rosemount 2410 is designed for use in hazardous area Zone 1 (Class 1, Division 1) and communicates with field devices in Zone 1 via the intrinsically safe Tankbus.

The Rosemount 2410 is available in three versions:

- single tank
- multiple tanks
- functional safety/SIS applications (SIL 2 single tank)

Figure 2-2: Rosemount 2410 Versions

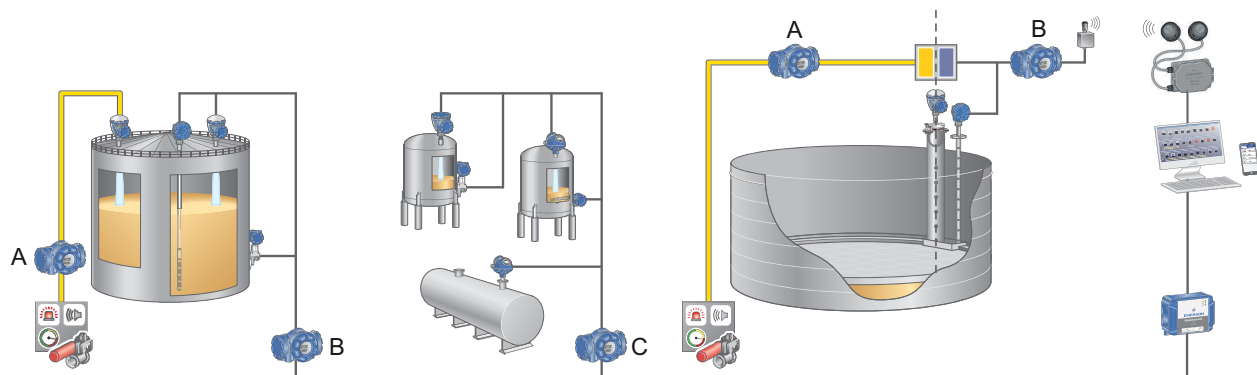

- A. Rosemount 2410: SIS Tank Hub
- B. Rosemount 2410 Tank Hub for single tanks
- C. Rosemount 2410 Tank Hub for multiple tanks

The multiple tanks version supports up to 10 tanks and 16 devices.

Measurement data and status information from one or more tanks is distributed via the Primary Bus to a Rosemount 2460 System Hub. Data is buffered by the system hub and distributed to a TankMaster PC, or a host system, whenever the 2460 receives a request for data. In case no system hub is included in the system, the Rosemount 2410 Tank Hub can communicate directly with a host computer.

The Rosemount 2410 has two external buses for communication with host systems. The **Primary Bus** is typically used with the TRL2 Modbus® or RS-485 Modbus protocol for communication with a 2460 System Hub. If there is no Rosemount 2460 included, the Primary bus can communicate directly, or via a modem, with the TankMaster PC.

The **Secondary Bus** supports various protocols such as TRL2 Modbus, Enraf®, and Varec which allows you to connect to other systems as well.

The Rosemount 2410 is equipped with two **solid state relays** that allows controlling external devices such as valves and pumps.

An **integral display** (optional) presents measurement data and device status such as warnings and error messages. At start-up, communication settings and optional hardware configuration is presented as well as whether it is a Single tank or Multiple tank version of the Rosemount 2410 Tank Hub.

Using the input from a Rosemount 5900S Radar Level Gauge and one or two pressure sensors, the Rosemount 2410 can be configured for online presentation of **Observed Density** to a host computer. The tank hub also calculates **Average Temperature** and strapping table based **Volume**.

The Rosemount 2410 can be equipped with two **relays** which can be controlled by level, temperature, and water level. The output can be connected to an external system for alarm indication or process control. The relays are user configurable for normally open or closed operation.

The Rosemount 2410 can be configured with up to ten **“virtual” relay** functions. This allows you to specify several different source variables to trigger a relay.

The Rosemount 2410 supports the Emerson’s Wireless solution, which is based on *WirelessHART*® the emerging industry standard for wireless field networks. By connecting to an Emerson Wireless 775 THUM™ Adapter, the Rosemount 2410 can be integrated in a wireless network to provide measurement data at greatly reduced field wiring costs.

2.2 Communication

The Rosemount Tank Gauging system supports various communication interfaces between a Rosemount 2410 and a TankMaster PC or other host computers as illustrated in [Figure 2-3](#) to [Figure 2-5](#).

Both the Primary bus and the Secondary bus can be used for either TRL2 Modbus (standard) or RS485 Modbus communication⁽²⁾.

On the Secondary bus you may use other communication protocols as well, such as Enraf, Varec etc.

Figure 2-3: Typical Configuration of a Rosemount 2410 and 2460 System Hub Connected to PC/Host

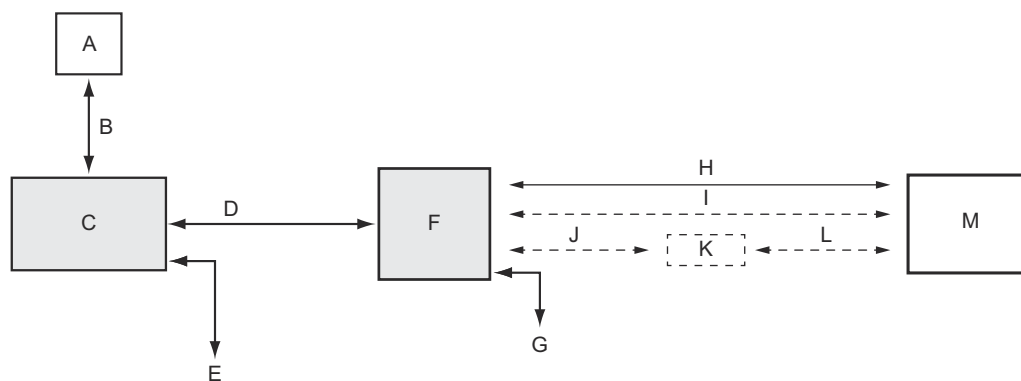

- A. Field devices
- B. Tankbus
- C. Rosemount 2410
- D. Primary bus: TRL2 Modbus, RS485 Modbus
- E. Secondary bus: Enraf and others, HART 4-20 mA analog output/input
- F. Rosemount 2460
- G. DCS
- H. Ethernet
- I. RS232
- J. TRL2 Modbus, RS485 Modbus
- K. Modem
- L. USB / RS232
- M. TankMaster

(2) See [Cabling for the TRL2/RS485 Bus](#) for information on cable requirements.

Figure 2-4: Typical Configuration of a Rosemount 2410 Connected to PC/Host

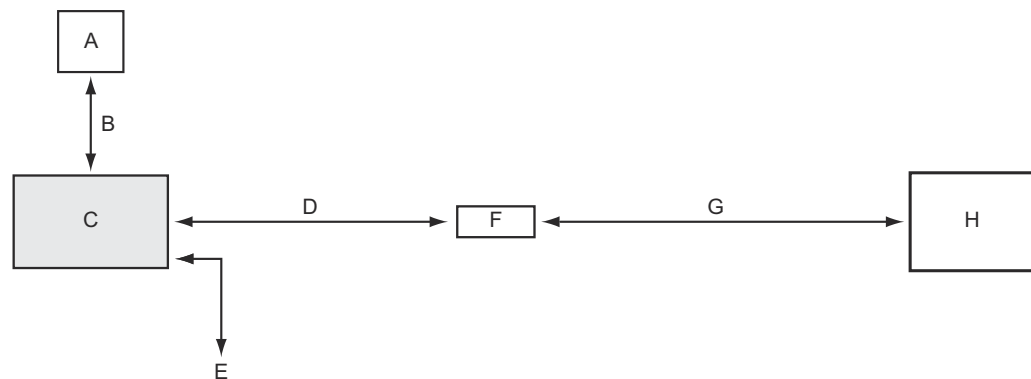

- A. Field devices
- B. Tankbus
- C. Rosemount 2410
- D. Primary bus: TRL2 Modbus, RS485 Modbus
- E. Secondary bus: Enraf and others, HART 4-20 mA analog output/input
- F. Modem
- G. USB / RS232
- H. TankMaster

A THUM Adapter, connected to the Intrinsically Safe Secondary⁽³⁾ bus, allows wireless communication between a Rosemount 2410 Tank Hub and an Emerson Wireless Gateway.

Figure 2-5: Typical Configuration of a Rosemount 2410 with Wireless Connection to Emerson Wireless Gateway and PC/Host

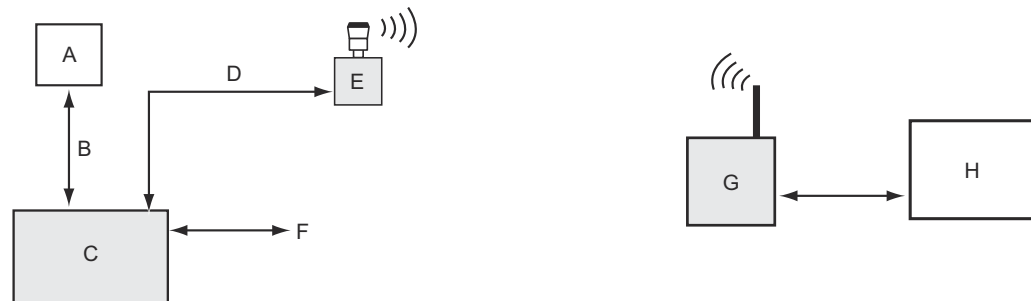

- A. Field devices
- B. Tankbus
- C. Rosemount 2410
- D. Secondary bus (IS): WirelessHART
- E. Emerson Wireless THUM Adapter
- F. Primary bus: TRL2 Modbus, RS485 Modbus
- G. Emerson Wireless Gateway
- H. TankMaster

⁽³⁾ The Non-IS Secondary Bus can not be used simultaneously with the IS HART 4-20 mA Secondary Bus.

2.3 Components

Figure 2-6: Rosemount 2410 Components

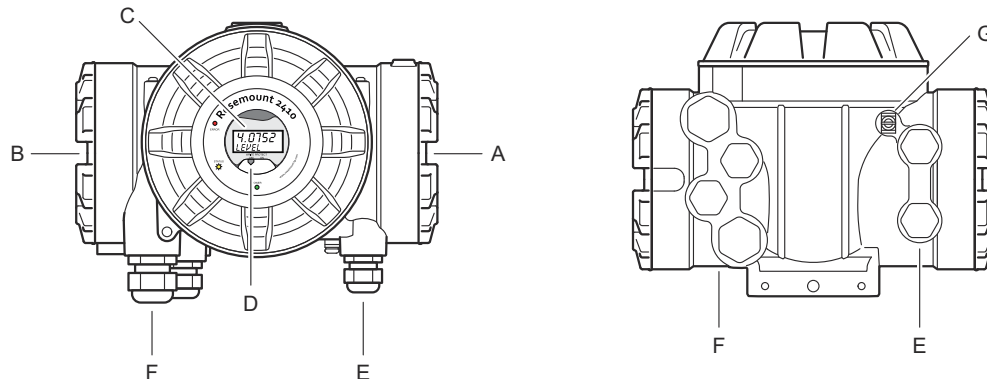

- A. Intrinsically safe terminal compartment
- B. Non-intrinsically safe terminal compartment
- C. Integral display (optional)
- D. Write protection switch
- E. Cable entries for IS connection (two $\frac{1}{2}$ - 14 NPT)
- F. Cable entries for Non-IS connection (two $\frac{1}{2}$ - 14 NPT, two $\frac{3}{4}$ - 14 NPT)
- G. Grounding terminal

2.4 System overview

The Rosemount Tank Gauging system is a state-of-the art inventory and custody transfer radar tank level gauging system. It is developed for a wide range of applications at refineries, tank farms and fuel depots, and fulfills the highest requirements on performance and safety.

The field devices on the tank communicate over the intrinsically safe Tankbus. The Tankbus is based on a standardized fieldbus, the FISCO⁽⁴⁾ FOUNDATION™ Fieldbus, and allows integration of any device supporting that protocol. By utilizing a bus powered 2-wire intrinsically safe fieldbus the power consumption is minimized. The standardized fieldbus also enables integration of other vendors' equipment on the tank.

The Rosemount Tank Gauging product portfolio includes a wide range of components to build small or large customized tank gauging systems. The system includes various devices, such as radar level gauges, temperature transmitters, and pressure transmitters for complete inventory control. Such systems are easily expanded thanks to the modular design.

The Rosemount Tank Gauging system is a versatile system that is compatible with and can emulate all major tank gauging systems. Moreover, the well-proven emulation capability enables step-by-step modernization of a tank farm, from level gauges to control room solutions.

It is possible to replace old mechanical or servo gauges with modern Rosemount Tank Gauging devices, without replacing the control system or field cabling. It is further possible to replace old HMI/SCADA-systems and field communication devices without replacing the old gauges.

There is a distributed intelligence in the various system units which continuously collect and process measurement data and status information. When a request for information is received an immediate response is sent with updated information.

The flexible Rosemount Tank Gauging system supports several combinations to achieve redundancy, from control room to the different field devices. Redundant network configuration can be achieved at all levels by doubling each unit and using multiple control room work stations.

⁽⁴⁾ See documents IEC 61158-2

Figure 2-7: Rosemount Tank Gauging System Architecture

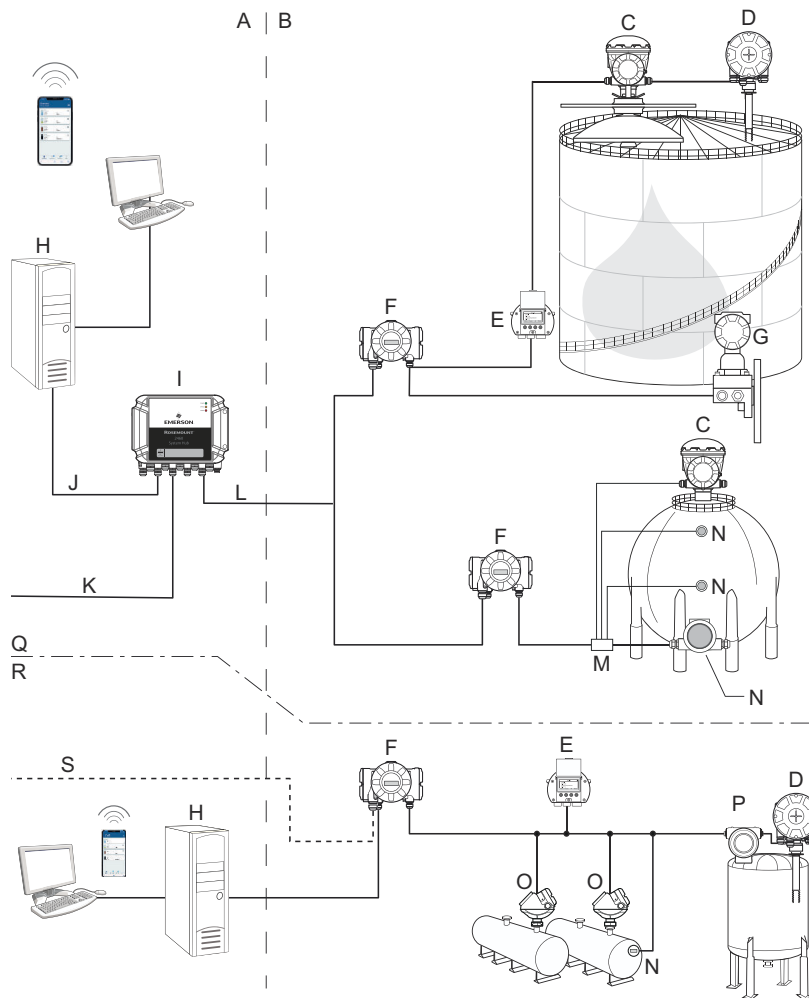

- | | |
|--|--|
| A. Non-hazardous area | K. Plant Host Computer |
| B. Hazardous area | L. TRL2 Modbus |
| C. Rosemount 5900S Radar Level Gauge | M. Segment coupler |
| D. Rosemount 2240S Temperature Transmitter | N. Rosemount 3144P Temperature Transmitter |
| E. Rosemount 2230 Graphical Field Display | O. Rosemount 5300 Level Transmitter |
| F. Rosemount 2410 Tank Hub | P. Rosemount 5408 Level Transmitter |
| G. Rosemount 3051S Pressure Transmitter | Q. Custody transfer / Inventory tank gauging |
| H. Rosemount TankMaster PC | R. Operational control |
| I. Rosemount 2460 System Hub | S. Plant host computer |
| J. Ethernet (Modbus TCP) | |

Figure 2-8: Rosemount Tank Gauging System Architecture for Wireless Systems

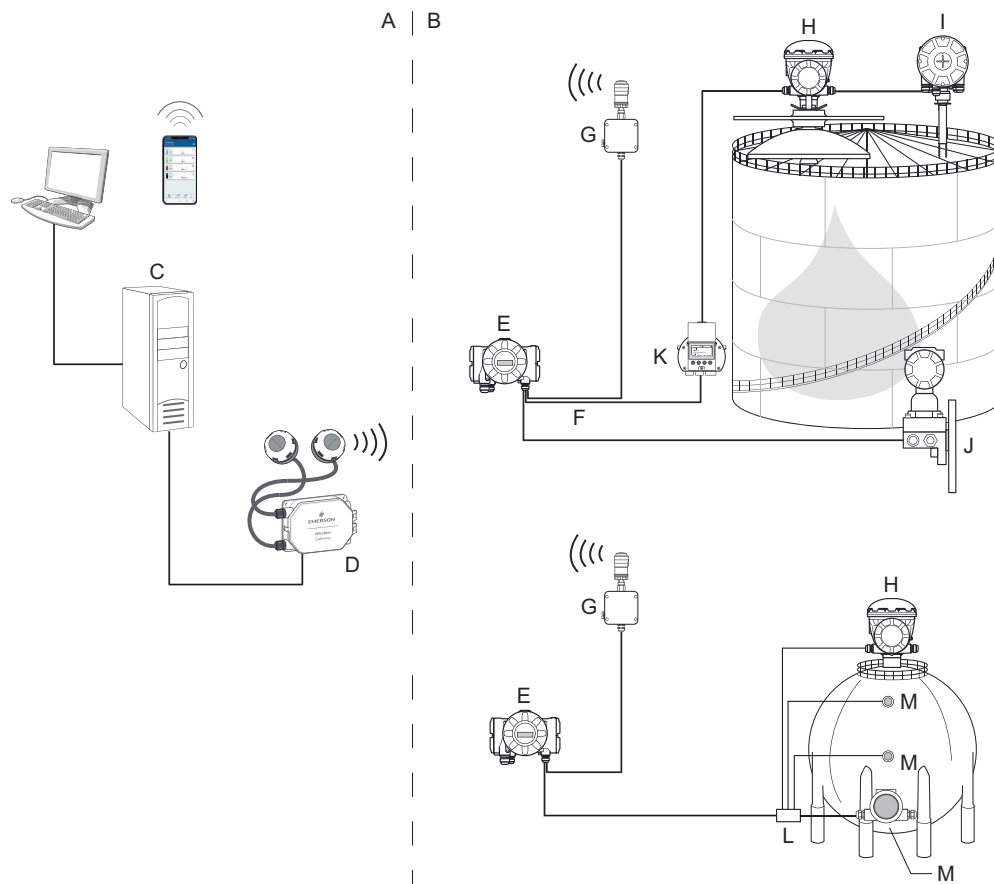

- A. Non-hazardous area
- B. Hazardous area
- C. Rosemount TankMaster PC
- D. Emerson Wireless Gateway
- E. Rosemount 2410 Tank Hub
- F. Tankbus
- G. Emerson Wireless 775 THUM Adapter
- H. Rosemount 5900S Radar Level Gauge
- I. Rosemount 2240S Temperature Transmitter
- J. Rosemount 3051S Pressure Transmitter
- K. Rosemount 2230 Graphical Field Display
- L. Segment coupler
- M. Rosemount 3144P Temperature Transmitter

Figure 2-9: Rosemount Tank Gauging System Architecture in a FOUNDATION Fieldbus Network

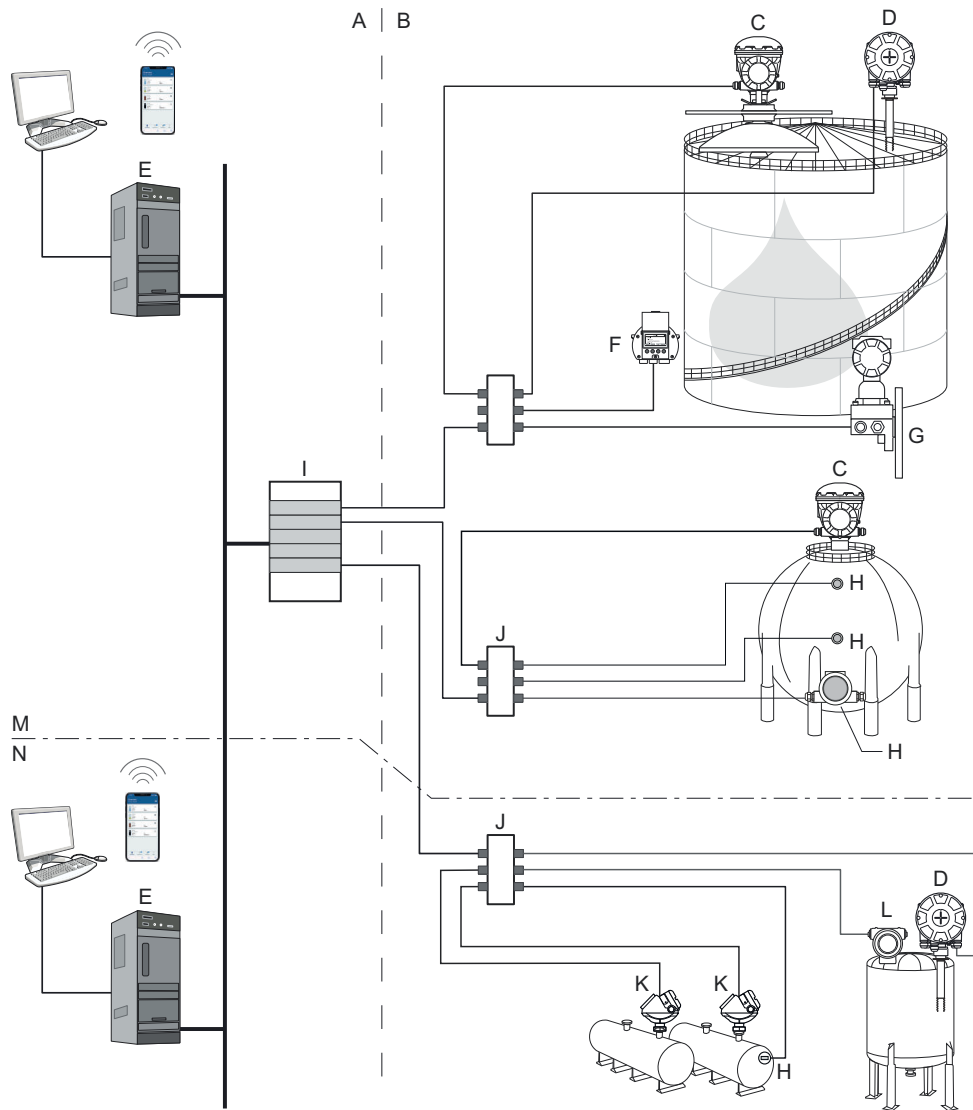

- | | | | |
|----|---|----|---|
| A. | Non-hazardous area | H. | Rosemount 3144P Temperature Transmitter |
| B. | Hazardous area | I. | FOUNDATION Fieldbus Power Supply |
| C. | Rosemount 5900S Radar Level Gauge | J. | Segment coupler |
| D. | Rosemount 2240S Temperature Transmitter | K. | Rosemount 5300 Level Transmitter |
| E. | PC | L. | Rosemount 5408 Level Transmitter |
| F. | Rosemount 2230 Graphical Field Display | M. | Custody transfer / Inventory tank gauging |
| G. | Rosemount 3051S Pressure Transmitter | N. | Operational control |

2.4.1 TankMaster HMI software

Rosemount TankMaster is a powerful Windows-based Human Machine Interface (HMI) for complete tank inventory management. It provides configuration, service, set-up, inventory, and custody transfer functions for Rosemount Tank Gauging systems and other supported instruments.

Rosemount TankMaster is designed to be used in the Microsoft® Windows environment providing easy access to measurement data from your Local Area Network (LAN).

The Rosemount TankMaster WinOpi program lets the operator monitor measured tank data. It includes alarm handling, batch reports, automatic report handling, historical data sampling as well as inventory calculations such as Volume, Observed Density and other parameters. A plant host computer can be connected for further processing of data.

The Rosemount TankMaster WinSetup program is a graphical user interface for installation, configuration and service of devices in the Rosemount Tank Gauging system.

2.4.2 Rosemount 2460 System Hub

The Rosemount 2460 System Hub is a data concentrator that continuously polls and stores data from field devices such as radar level gauges and temperature transmitters in a buffer memory. Whenever a request for data is received, the system hub can immediately send data from the updated buffer memory for a group of tanks.

Measured and calculated data from one or more tanks is communicated via the Rosemount 2410 Tank Hub to the system hub buffer memory. Whenever a request is received, the system hub can immediately send data from a group of tanks to a TankMaster PC, or a host.

The Rosemount 2460 can be used to connect devices from other vendors as well, such as Honeywell® Enraf and Whessoe.

The Rosemount 2460 has eight slots for communication interface boards. These boards can be individually configured for communication with hosts or field devices. They can be ordered either for TRL2, RS485, Enraf BPM or Whessoe 0-20 mA/RS485 communication. Two slots can also be configured for RS232 communication.

One of the system hub's three Ethernet ports is used for Modbus TCP connection to host systems. By simply connecting the system hub to the existing LAN network, communication over Ethernet is established.

The system hub can provide redundancy for critical operations, by using two identical devices. The primary system hub is active and the other one is in passive mode. If the primary unit stops working properly, the secondary unit is activated and a failure message is sent to TankMaster (or a DCS system).

2.4.3 Rosemount 2410 Tank Hub

The Rosemount 2410 Tank Hub acts as a power supply to the connected field devices in the hazardous area using the intrinsically safe Tankbus.

The tank hub collects measurement data and status information from field devices on a tank. It has two external buses for communication with various host systems.

The Rosemount 2410 is available in three versions:

- single tank
- multiple tanks
- functional safety/SIS applications (SIL 2 single tank)

The multiple tanks version of the Rosemount 2410 supports up to 10 tanks and 16 devices. With the Rosemount 5300 the Rosemount 2410 supports up to 5 tanks.

The Rosemount 2410 is equipped with two relays which support configuration of up to 10 “virtual” relay functions allowing you to specify several source signals for each relay.

The Rosemount 2410 supports Intrinsically Safe (IS) and Non-Intrinsically Safe (Non-IS) analog 4-20 mA inputs/outputs. By connecting an Emerson Wireless 775 THUM Adapter to the IS HART 4-20 mA output, the tank hub is capable of wireless communication with an Emerson Wireless Gateway in a *WirelessHART*[®] network.

2.4.4 Rosemount 5900S Radar Level Gauge

The Rosemount 5900S Radar Level Gauge is an intelligent instrument for measuring the product level inside a tank. Different antennas can be used in order to meet the requirements of different applications. The Rosemount 5900S can measure the level of almost any product, including bitumen, crude oil, refined products, aggressive chemicals, LPG and LNG.

The Rosemount 5900S sends microwaves towards the surface of the product in the tank. The level is calculated based on the echo from the surface. No part of the Rosemount 5900S is in actual contact with the product in the tank, and the antenna is the only part of the gauge that is exposed to the tank atmosphere.

The 2-in-1 version of the Rosemount 5900S Radar Level Gauge has two radar modules in the same transmitter housing allowing two independent level measurements using one antenna and one tank opening.

2.4.5 Rosemount 5300 Guided Wave Radar

The Rosemount 5300 is a premium 2-wire guided wave radar for level measurements on liquids, to be used in a wide range of medium accuracy applications under various tank conditions. Rosemount 5300 includes the Rosemount 5301 for liquid level measurements and the Rosemount 5302 for liquid level and interface measurements.

2.4.6 Rosemount 5408 Radar Level Transmitter

The Rosemount 5408 is a non-contacting level transmitter for accurate and reliable level measurement on small storage and buffer tanks.

The Rosemount 5408 provides accurate and reliable level measurements for metallic and non-metallic vessels. It is suitable for almost any liquid and is ideal for challenging applications with agitators, foam, high temperatures, and pressures. It is also an excellent choice for level measurement in tanks with small diameter (2- to 4-inch) stilling wells.

The narrow beam makes the Rosemount 5408 the ideal solution for bulk solids in small to medium sized silos with rapid level changes.

For safety functions such as overflow prevention, level deviation monitoring, or dry-run prevention, the Rosemount 5408:SIS is the ideal choice.

2.4.7 Rosemount 2240S Multi-Input Temperature Transmitter

The Rosemount 2240S Multi-input Temperature Transmitter can connect up to 16 temperature spot sensors and an integrated water level sensor.

2.4.8 Rosemount 2230 Graphical Field Display

The Rosemount 2230 Graphical Field Display presents inventory tank gauging data such as level, temperature, and pressure. The four softkeys allow you to navigate through the different menus to provide all tank data, directly in the field. The Rosemount 2230 supports up to 10 tanks. Up to three Rosemount 2230 displays can be used on a single tank.

2.4.9 Rosemount 3144P Temperature Transmitter

The Rosemount 3144P is used with single spot temperature sensors.

2.4.10 Rosemount 3051S Pressure Transmitter

The Rosemount 3051S series consists of transmitters and flanges suitable for all kinds of applications, including crude oil tanks, pressurized tanks and tanks with / without floating roofs.

By using a Rosemount 3051S Pressure Transmitter near the bottom of the tank as a complement to a Rosemount 2410 Radar Level Gauge, the density of the product can be calculated and presented. One or more pressure transmitters with different scalings can be used on the same tank to measure vapor and liquid pressure.

2.4.11 Rosemount 2180 Field Bus Modem

The Rosemount 2180 Field Bus Modem (FBM) is used for connecting a TankMaster PC to the TRL2 communication bus. The Rosemount 2180 is connected to the PC using either the USB or the RS232 interface.

2.4.12 Emerson Wireless Gateway and Emerson Wireless 775 THUM™ Adapter

An Emerson Wireless THUM Adapter allows wireless communication between a Rosemount 2410 Tank Hub and an Emerson Wireless Gateway. The gateway is the network manager that provides an interface between field devices and the Rosemount TankMaster inventory software or host/DCS systems.

See the Rosemount Tank Gauging [System Data Sheet](#) for more information on the various devices and options.

2.5 Installation procedure

Follow these steps for a proper installation:

Procedure

1. Review Mounting Considerations.
See [Installation considerations](#).
2. Mount the Rosemount 2410 Tank Hub.
See [Mechanical installation](#).
3. Wire the Rosemount 2410.
See [Electrical installation](#).
4. Make sure covers and cable/conduit connections are tight.
5. Power up the Rosemount 2410.
6. Configure the Rosemount 2410 ([Configuration](#)):
 - tank database
 - tags
 - integral display
 - Primary/Secondary Bus
 - Relay output
 - Hybrid density
7. Verify operation.
8. Optional: Enable the Write Protection switch if required.

3 Installation

3.1 Safety messages

Instructions and procedures in this section may require special precautions to ensure the safety of the personnel performing the operations. Information that potentially raises safety issues is indicated by a warning symbol () . Refer to the following safety messages before performing an operation preceded by this symbol.

WARNING

Failure to follow safe installation and servicing guidelines could result in death or serious injury.

Ensure only qualified personnel perform the installation.

Use the equipment only as specified in this manual. Failure to do so may impair the protection provided by the equipment.

Do not perform any services other than those contained in this manual unless you are qualified.

WARNING

Explosions could result in death or serious injury.

Verify that the operating atmosphere of the transmitter is consistent with the appropriate hazardous locations certifications.

Before connecting a handheld communicator in an explosive atmosphere, ensure that the instruments in the loop are installed in accordance with intrinsically safe or non-incendive field wiring practices.

Do not remove the gauge cover in explosive atmospheres when the circuit is alive.

To prevent ignition of flammable or combustible atmospheres, disconnect power before servicing.

WARNING

High voltage that may be present on leads could cause electrical shock.

Avoid contact with leads and terminals.

Ensure the main power to the Rosemount 2410 Tank Hub is off and the lines to any other external power source are disconnected or not powered while wiring the device.

3.2 Installation considerations

The Rosemount 2410 Tank Hub may be installed on various locations at the plant. Mounting at the tank foot may be convenient when you would like to have easy access to measuring data, diagnostics and other information on the optional integral display.

The tank hub can also be mounted on the tank roof if this is the preferred location. In case the tank hub is exposed to long periods of sunshine, a sunshade should be used to prevent it from being heated to temperatures above the maximum operating temperature.

Ensure that environmental conditions are within specified limits as listed in [Specifications and reference data](#).

Ensure that the Rosemount 2410 is installed such that it is not exposed to higher temperature than specified in [Specifications and reference data](#).

The multi-tank version of the Rosemount 2410 Tank Hub is able to serve several tanks. In that case it may be placed at a suitable location further away from the tanks.

The Rosemount 2410 is designed with two Tankbus terminals and several cable entries which allows alternative cable routing to suit various requirements.

Do not install the Rosemount 2410 in non-intended applications, for example environments where it may be exposed to extremely intense magnetic fields or extreme weather conditions.

Important

Check the Rosemount 2410 Tank Hub for any signs of damage prior to installation. Ensure that the glass on the integral display is undamaged, and O-rings and gaskets are in good condition.

3.2.1 Installation planning

It's recommended to plan the installation in order to ensure that all components in the system are properly specified. The planning stage should include the following tasks:

- Make a plan of the site and specify suitable locations for the devices
- Consider power budget
- Specify cabling and connections (for example whether devices will be "daisy-chained" or not)
- Specify cable glands that will be needed for the various devices
- Specify location of terminators on the Tankbus
- Make a note of identification codes such as Unit ID/Device ID of each device
- Assign Modbus® addresses for level gauges and other tank devices to be used in the tank databases of the Rosemount 2410 and the Rosemount 2460

Related information

[Rosemount Tank Gauging System Configuration Manual](#)
[Electrical installation](#)

3.3 Mechanical installation

The Rosemount 2410 is designed for mounting on a pipe stand or on a wall.

3.3.1 Pipe mounting

Prerequisites

Note

Ensure that the Rosemount 2410 is installed to minimize vibration and mechanical shock.

Procedure

1. Attach the bracket to the pipe.

Ensure that the Rosemount 2410 is placed in a direction so that the display is clearly visible and wiring can be properly connected.

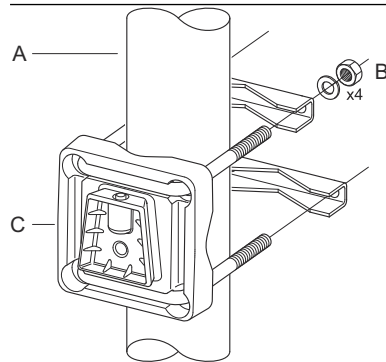

- A. 1 - 2 inches
- B. 4 nuts and washers
- C. Bracket

2. Tighten the nuts. Use moderate torque to ensure that the bracket does not break.
3. Attach the tank hub to the bracket by sliding it from the top downwards.

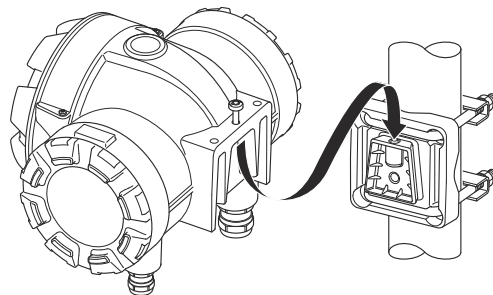

4. Secure the tank hub to the bracket by tightening the screw.

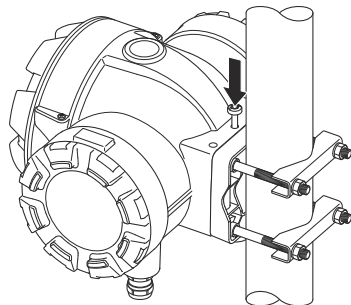

3.3.2 Wall mounting

Prerequisites

Note

Ensure that the Rosemount 2410 is installed such that vibration and mechanical shock is minimized.

Procedure

1. Mount the bracket on the wall by using four M8 screws and flat washers.

Note

Countersunk screws are not suitable.

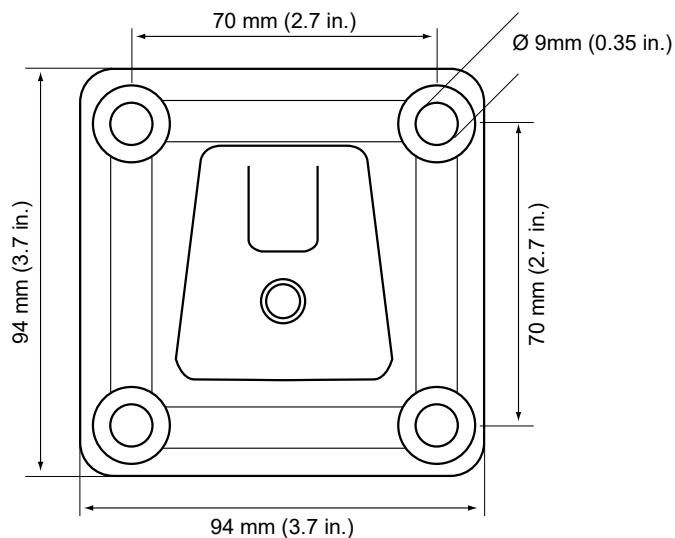

2. Attach the tank hub to the bracket and tighten the screw.

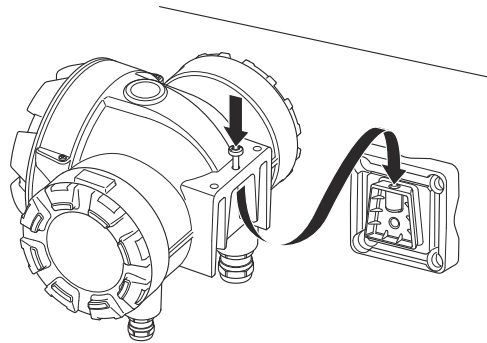

3.4 Electrical installation

3.4.1 Cable entries

The Rosemount 2410 electronics housing has four $\frac{1}{2}$ - 14 NPT and two $\frac{3}{4}$ - 14 NPT entries. The connections must be made in accordance with local or plant electrical codes.

Make sure that unused ports are properly sealed to prevent moisture or other contamination from entering the terminal block compartment of the electronics housing.

Note

Use the enclosed metal plugs to seal unused ports. The plastic plugs mounted at delivery are not sufficient as seal!

Note

Thread sealing (PTFE) tape or paste on male threads of conduit is required to provide a water/dust tight conduit seal and to meet the required degree of ingress protection as well as to enable future removal of the plug/gland.

Note

NPT is a standard for tapered threads. Tightening torque is not given by the standard. Common recommendation is to tighten the NPT gland by hand and then use a wrench to tighten the NPT gland. Keep in mind that over tightening may be detrimental for the sealing function or even damage the threads in the housing. Engage the gland with 5 to 6 threads. Note that there will be a number of threads left outside the housing as in [Figure 3-1](#).

Figure 3-1: Cable Entry with NPT Threaded Gland

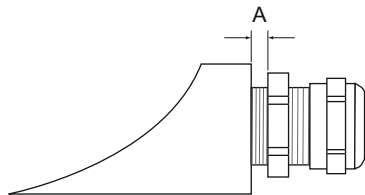

A. The NPT threaded gland leaves a number of threads outside the housing

Glands must meet the following requirements for the Non-IS cable entries:

- Ex de explosion protection
- IP class 66 and 67
- material: metal (recommended)

3.4.2 Power supply

The Rosemount 2410 Tank Hub accepts supply voltage 48 - 240 Vac (50/60 Hz) and 24 - 48 Vdc. The Rosemount 2410 provides intrinsically safe power to all devices connected to the Tankbus.

Related information

[Tankbus](#)

3.4.3 Cable selection for power supply



Cables must be suitable for the supply voltage and approved for use in hazardous areas, where applicable. For instance, in the U.S., explosion-proof conduits must be used in the vicinity of the vessel.

Suitable conduits with sealing device or flame proof cable glands must be used depending on local requirements.

Appropriate cross sectional area of wires must be used in order to prevent a too high voltage drop to the connected device. Use 0.75 mm² to 2.5 mm² (18 AWG to 13 AWG) in order to minimize the voltage drop.

3.4.4 Grounding

The housing should always be grounded in accordance with national and local electrical codes. Failure to do so may impair the protection provided by the equipment. The most effective grounding method is direct connection to earth ground with minimal impedance.

There are grounding screw connections inside the terminal compartments which are identified by ground symbols:  / . There is also a grounding screw on the housing.

Note

Grounding the device via threaded conduit connection may not provide sufficient ground.

Grounding - Tankbus

Signal wiring of the fieldbus segment (Tankbus) can not be grounded. Grounding one of the signal wires may shut down the entire fieldbus segment.

Shield wire ground

Tankbus

To protect the fieldbus segment (Tankbus) from noise, grounding techniques for shield wire usually require a single grounding point for shield wire to avoid creating a ground loop. The ground point is typically at the power supply.

The Rosemount Tank Gauging devices are designed for “daisy-chain” connection of shield wiring in order to enable a continuous shield throughout the Tankbus network.

Primary/Secondary Bus

Cable shield for the Primary and Secondary Bus should normally be grounded at host or System Hub end only.

3.4.5 Cable selection for the Tankbus

Use shielded twisted pair wiring for the Rosemount 2410 Series in order to comply with FISCO⁽⁵⁾ requirements and EMC regulations. The preferred cable is referred to as type “A” fieldbus cable. The cables must be suitable for the supply voltage and approved for use in hazardous areas, where applicable. In the U.S. explosion-proof conduits may be used in the vicinity of the vessel.

We recommend cable size 1.0 mm² or 18 AWG in order to facilitate wiring. However, cables within the range 0.5 to 1.5 mm² or 20 to 16 AWG can be used.

(5) See IEC 61158-2

The FISCO FOUNDATION™ Fieldbus specification requires that cables for the Tankbus comply with the following cable parameters:

Table 3-1: FISCO Cable Parameters

Parameter ⁽¹⁾	Value
Loop resistance	15 Ω/km to 150 Ω/km
Loop inductance	0.4 mH/km to 1 mH/km
Capacitance	45 nF/km to 200 nF/km
Maximum length of each spur ⁽²⁾ cable	60 m in apparatus class IIC and IIB
Maximum cable length including trunk ⁽³⁾ and spurs	1000 m in apparatus class IIC and 1900 m in apparatus class IIB

- (1) For further information see requirements of the IEC 61158-2 standard.
- (2) A spur is an unterminated part of the network.
- (3) A trunk is the longest cable path between two devices on the fieldbus network, and is the part of the network which has terminations at both ends. In the Rosemount Tank Gauging system, a trunk is typically located between the Rosemount 2410 Tank Hub and a segment coupler or the last device in a daisy-chain configuration.

3.4.6 Power budget

The Rosemount 2410 Tank Hub delivers 250 mA to the Tankbus. In wireless systems a Rosemount 2410 Tank Hub equipped with active analog inputs/outputs may deliver 200 mA. The number of tanks served by the tank hub depends on the type of connected field devices and their power consumption⁽⁶⁾. Power consumption per field device is listed in [Table 3-2](#).

Table 3-2: Power Consumption for Various Rosemount Tank Gauging Devices

Field device	Power consumption
Rosemount 5900S Radar Level Gauge	50 mA
Rosemount 5900C Radar Level Gauge	50 mA
Rosemount 5900S Radar Level Gauge, 2-in-1 solution	100 mA
Rosemount 5300 Level Transmitter	21 mA
Rosemount 5408 Level Transmitter	21 mA
Rosemount 2230 Graphical Field Display	30 mA
Rosemount 2240S Multi-input Temperature Transmitter	30 mA including 565, 566 and 765 temperature sensors
Rosemount 3144P Temperature Transmitter	12 mA
Rosemount 3051S, and Rosemount 2051 Pressure Transmitters	18 mA

The Rosemount 2410 Tank Hub is available in a single tank version as well as a multiple tank version which supports up to 10 tanks⁽⁷⁾.

3.4.7 Tankbus

The Rosemount Tank Gauging system is easy to install and wire. Devices can be “daisy-chained” thus reducing the number of external junction boxes.

In a Rosemount Tank Gauging system devices communicate with a Rosemount 2410 Tank Hub via the intrinsically safe Tankbus. The Tankbus complies with the FISCO⁽⁸⁾ FOUNDATION Fieldbus standard. The Rosemount 2410 acts as power supply to the field devices on the Tankbus. A FISCO system enables more field devices to be connected to the segment compared to conventional IS systems based on the entity concept.

The tank hub is designed for use in hazardous area Zone 1 (Class 1, Division 1) and communicates with field devices via the intrinsically safe Tankbus.

Termination

A terminator is needed at each end of a FOUNDATION™ Fieldbus network. A trunk is defined as the longest cable path between two devices on the fieldbus network. In the Rosemount Tank Gauging system, a trunk is typically located between the Rosemount 2410 Tank Hub and a splitter or the last device in a daisy-chain configuration. Generally, one terminator is placed in the fieldbus power supply, and the other one in the last device in the fieldbus network.

⁽⁶⁾ May be fewer than the 16 devices per segment, stated in the FOUNDATION™ Fieldbus standard.

⁽⁷⁾ Maximum five Rosemount 5300 level transmitters.

⁽⁸⁾ FISCO=Fieldbus Intrinsically Safe Concept

Note

Ensure that there are **two** terminators on the fieldbus.

In a Rosemount Tank Gauging system the Rosemount 2410 Tank Hub acts as power supply. Since the tank hub normally is the first device in the fieldbus segment, the built-in termination is enabled at factory.

Other devices such as the standard version of the Rosemount 5900S Radar Level Gauge, the Rosemount 2230 Graphical Field Display, and the Rosemount 2240S Multi-input Temperature Transmitter also have built-in terminators which can easily be enabled by inserting a jumper in the terminal block when necessary.

When adding new devices at the end of an existing FOUNDATION Fieldbus network, the termination is moved to the farthest field device in order to fulfill the requirement on locating the terminator at the end of the trunk. However, in case a field device is added to the network with a short cable, this rule may be slightly bent by leaving the terminator in its original position.

Fieldbus segment design

When designing a FISCO fieldbus segment you will have to make sure that cabling complies with FISCO requirements as described in [Cable selection for the Tankbus](#).

You will also have to ensure that the total operating current of the connected field devices is within the output capability of the Rosemount 2410 Tank Hub. The tank hub is able to deliver 250 mA⁽⁹⁾. Consequently, the total number of field devices has to be considered so that the total current consumption is less than 250 mA, see [Power budget](#).

Since the field devices on the Tankbus must have at least a 9 V input voltage at their terminals, you will have to take into account the voltage drop in the fieldbus cables. In many cases distances are relatively short between the Rosemount 2410 and field devices on the tank and you may use existing cables as long as the FISCO requirements are fulfilled (see [Cable selection for the Tankbus](#)).

Typical characteristics for such a cable is:

Table 3-3: Typical Characteristics of Instrumentation Cable

Parameter	Value
Loop resistance	42 Ω/km
Inductance	0.65 mH/km
Capacitance	115 nF/km
Cross-sectional area	0.75 mm ² (18 AWG)

The Rosemount 2410 outputs 12.5 Vdc. Considering the minimum voltage supply of 9 V on the field device terminals, a maximum voltage drop of 3.5 V on the Tankbus can be allowed. At a maximum current consumption of 250 mA (12.5 Vdc) with all field devices located at the far end of the Tankbus, a total “worst case” cable resistance of approximately 14 Ω (3.5 V/250 mA) is allowed. This corresponds to a cable length of 333 m (1092 ft) in case typical cable characteristics are assumed as specified in [Table 3-3](#).

However, normally the current consumption is less than 250 mA. A typical configuration would include a tank supplied with a Rosemount 5900S Radar Level Gauge, a Rosemount 2230 Graphical Field Display, a Rosemount 2240S Multi-input Temperature Transmitter, and a Rosemount 3051S Pressure Transmitter. In this case the current consumption would be 128 mA allowing a cable length of 677 m (2221 ft) between the Rosemount 2410 Tank

⁽⁹⁾ In wireless systems the Rosemount 2410 can deliver 200 mA on the Tankbus.

Hub and the field devices on the tank. With fewer devices on the Tankbus, an even longer cable would be allowed.

Table 3-4 shows the maximum distance between a Rosemount 2410 Tank Hub and the field devices on a tank for different cable cross-sectional areas. The table shows the maximum distance to a tank at a total current consumption of 250 mA as well as for a typical installation as outlined above.

Table 3-4: Maximum Distance from Power Source to Field Devices on the Tank for Different Cable Areas

Cable characteristics		Maximum distance to tank (m/ft)	
Cross-sectional area	Typical loop resistance (Ω /km)	Maximum Current consumption (250 mA)	Typical installation (128 mA)
20 AWG (0.5 mm ²)	66	212 (695)	414 (1358)
18 AWG (0.75 mm ²)	42	333 (1092)	651 (2136)
17 AWG (1.0 mm ²)	33	424 (1391)	829 (2720)
16 AWG (1.5 mm ²)	26	538 (1765)	1052 (3451)

Related information

[Cable selection for the Tankbus](#)

Example 1

The example illustrated in Figure 3-2 includes a tank located 300 m away from a Rosemount 2410 Tank Hub acting as power supply. In the calculations below it is assumed that the cable length between the field devices on the tank can be ignored.

The tank is equipped with the following field devices: a Rosemount 5900S Radar Level Gauge, a Rosemount 2240S Multi-input Temperature Transmitter, and a Rosemount 2230 Graphical Field Display. The total current consumption of the three devices is 110 mA (see Table 3-2).

Figure 3-2: Installation on One Tank

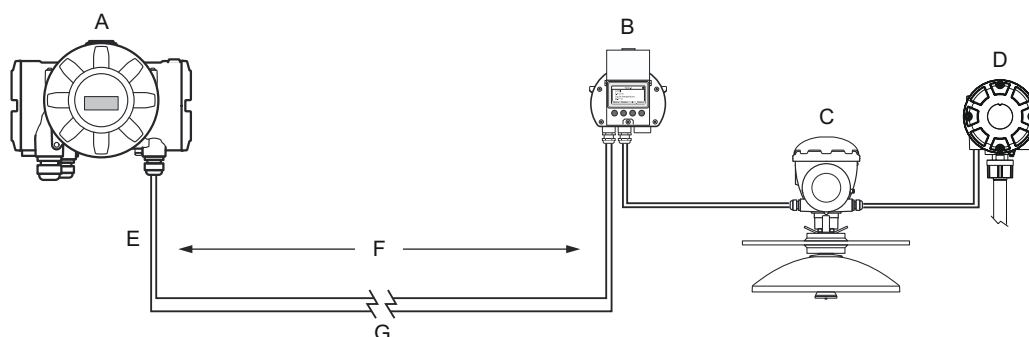

- A. Rosemount 2410 Tank Hub
- B. Rosemount 2230 Display
- C. Rosemount 5900S Radar Level Gauge
- D. Rosemount 2240S Temperature Transmitter
- E. Tankbus
- F. 300 m
- G. Voltage drop=1.4 V

The total operating current of the connected field devices on the tank is $50+30+30 \text{ mA}=110 \text{ mA}$. This is within the output capability of the Rosemount 2410 Tank Hub.

Calculations

The tank hub is powered by an intrinsically safe power supply: 12.5 V, 250 mA.

Voltage drop to the tank: $110 \text{ mA} \times 0.30 \text{ km} \times 42 \Omega/\text{km}=1.4 \text{ V}$.

Voltage at the tank $=12.5 \text{ V} - 1.4 \text{ V}=11.1 \text{ V}$.

Result: the input voltage of 11.1 V to the field devices is above the minimum requirement of 9 V.

Related information

[Power budget](#)

Example 2

The second example, illustrated in [Figure 3-3](#), includes two tanks with a Rosemount 2410 Tank Hub acting as power supply to the field devices on both tanks.

The first tank is located 300 m away from the Rosemount 2410 Tank Hub and the second tank a further 350 m away.

Both tanks have two field devices: a Rosemount 5408 Radar Level Transmitter and a Rosemount 3144P Temperature Transmitter. The total current consumption of the two devices is 32 mA (see [Table 3-2](#)).

Figure 3-3: Example of Installation on Two Tanks

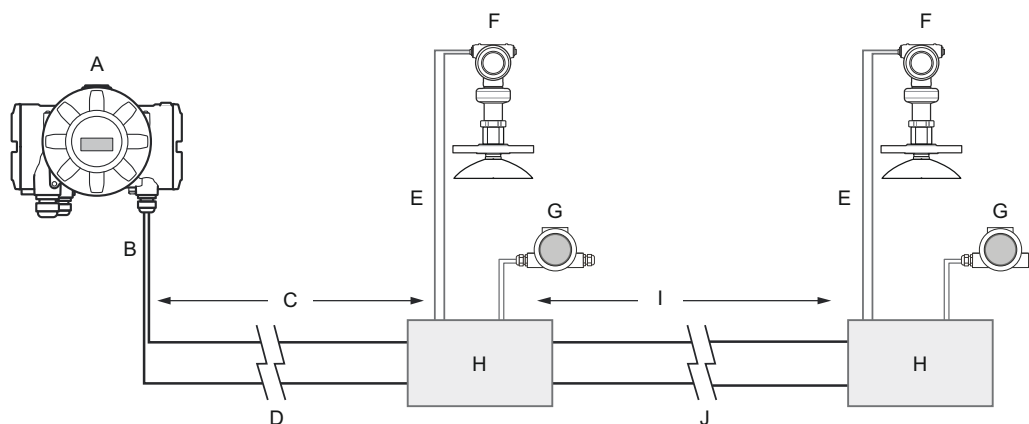

- A. Rosemount 2410 Tank Hub
- B. Tankbus
- C. 300 m
- D. Voltage drop=0.80 V
- E. (Spur < 60 m)
- F. Rosemount 5408 Level Transmitter
- G. Rosemount 3144P Temperature Transmitter
- H. Segment coupler
- I. 350 m
- J. Voltage drop=0.47 V

The total operating current of the connected field devices on the two tanks is $32+32 \text{ mA}=64 \text{ mA}$. This is within the output capability of the Rosemount 2410 Tank Hub.

Calculations

The tank hub is powered by an intrinsically safe power supply: 12.5 V, 250 mA.

Voltage drop to the first tank: $64 \text{ mA} \times 0.30 \text{ km} \times 42 \text{ } \Omega/\text{km} = 0.80 \text{ V}$.

Voltage at first tank = $12.5 \text{ V} - 0.80 \text{ V} = 11.70 \text{ V}$.

Voltage drop between first and second tank: $32 \text{ mA} \times 0.35 \text{ km} \times 42 \text{ } \Omega/\text{km} = 0.47 \text{ V}$.

Voltage at second tank = $12.5 \text{ V} - 0.80 \text{ V} - 0.47 \text{ V} = 11.23 \text{ V}$.

For both tanks the input voltage to the field devices is above the minimum requirement of 9 V.

The field devices may be connected to the Tankbus via segment couplers as illustrated in [Figure 3-3](#). The spur length must not exceed 60 m according to the FISCO standard. In the example above, it is assumed that the voltage drop between the segment coupler and the devices can be ignored.

Related information

[Power budget](#)

Tankbus Segment coupler

In case “daisy-chain” connection is not suitable, a Tankbus Segment Coupler⁽¹⁰⁾ can be used to connect the various devices.

Features:

- Entity and FISCO compliant
- adjustable short-circuit limit
- robust die-cast aluminium housing
- protection degree IP67
- integrated bus terminating resistor (switch integrated inside the housing)
- cable shielding: capacitive or direct connection to housing potential selectable via switch

Note

Sufficient equipotential bonding of the installation must be ensured. The device is connected via the bolt on the housing to the system's potentializer.

⁽¹⁰⁾ Part no. 6853511-493. Contact Emerson Automation Solutions/Rosemount Tank Gauging for more information.

Figure 3-4: Dimensions (mm)

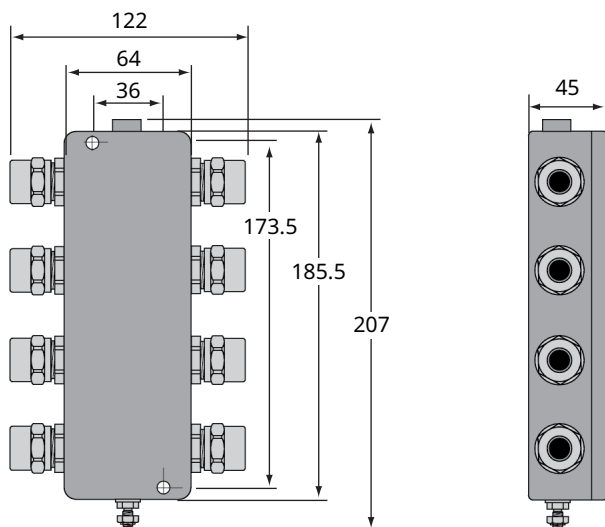
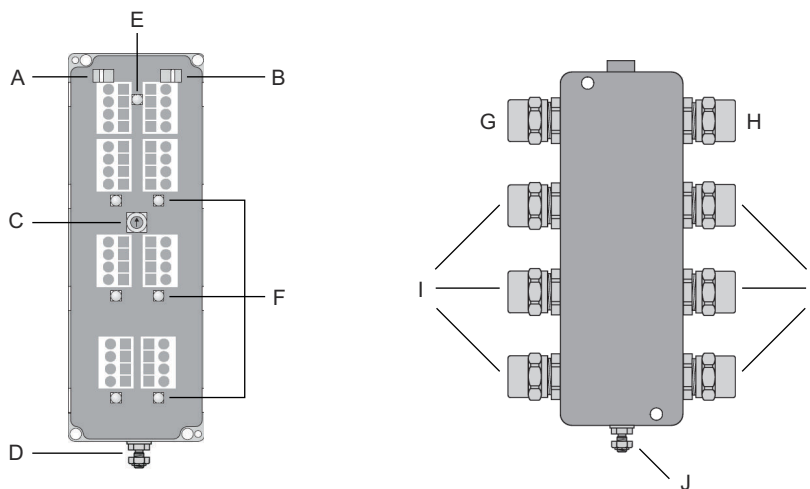

Figure 3-5: Segment coupler features



- A. Switch for capacitive or direct connection between shield and housing potential
- B. Switch for activating terminating resistor
- C. Current limitation for all ports via a rotary switch; 30, 35, 45, or 60 mA
- D. Connection of housing potential
- E. LED power on indication
- F. LED short-circuit indication
- G. Trunk IN
- H. Trunk OUT
- I. Spurs
- J. Case ground

In case there are different device types connected to the segment coupler, set the current limitation switch (3) to the closest value above the largest current consumption of the

connected devices. See [Table 3-2](#) for information on current consumption for various Rosemount Tank Gauging devices.

Examples

Rosemount 5900S; set the switch to 60mA.

Rosemount 5300 and 5408; set the switch to 30 mA.

Rosemount 2230; set the switch to 35 mA.

Figure 3-6: Field Devices Connected via Segment Couplers

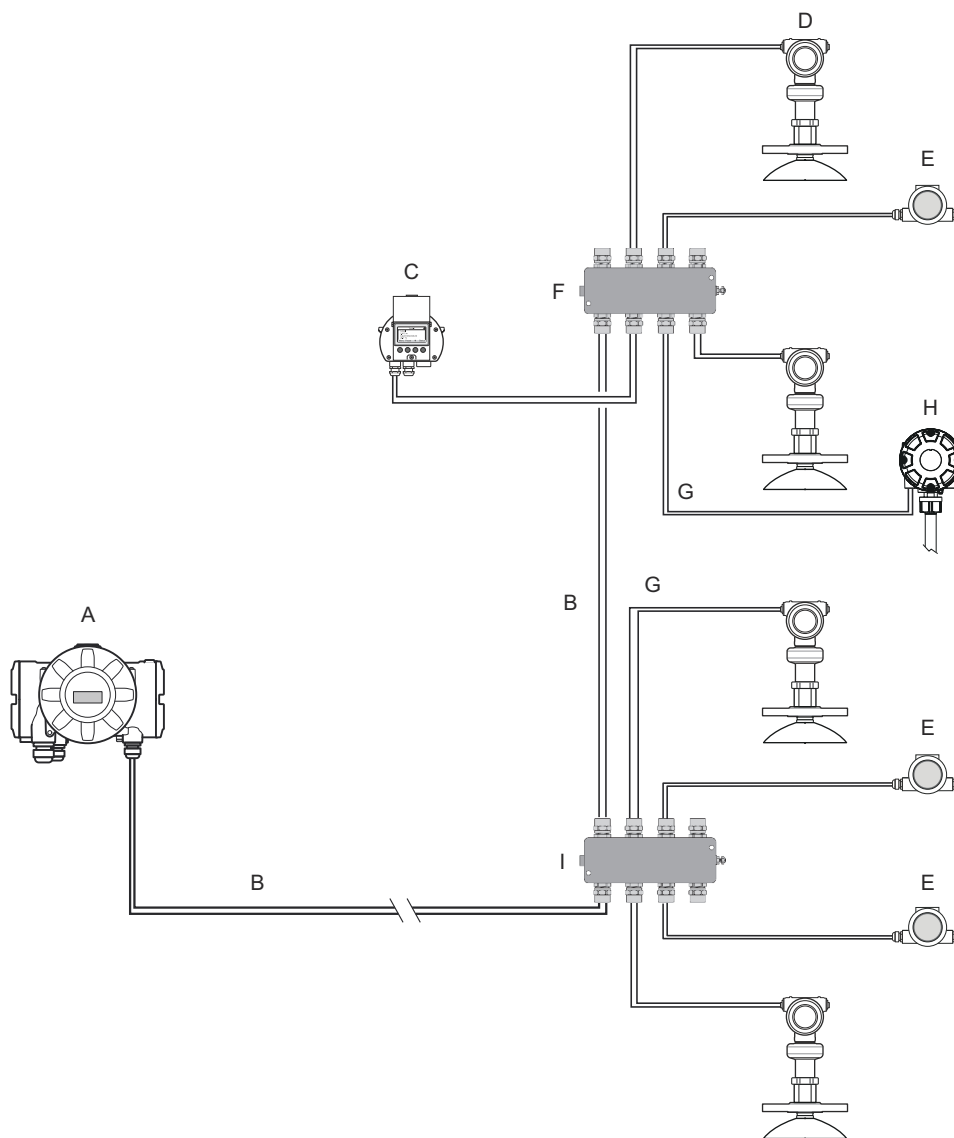

- A. Rosemount 2410 Tank Hub
- B. Tankbus (trunk)
- C. Rosemount 2230 Display
- D. Rosemount 5408 Level Transmitter
- E. Rosemount 3144P Temperature Transmitter
- F. Segment coupler with active terminator (end of trunk)
- G. (Spur < 60 m)
- H. Rosemount 2240S Temperature Transmitter
- I. Segment coupler

Related information

[Power budget](#)

3.4.8 Typical installations

System with devices connected to a Rosemount 2410 on a single tank

The example in [Figure 3-7](#) illustrates a system with daisy-chained field devices on a single tank. Terminators are installed at both ends of the fieldbus segment as required in a FOUNDATION™ Fieldbus system. In this example the terminators are enabled in the Rosemount 2410 Tank Hub and a field device (Rosemount 2240S) at the end of the network segment.

In addition to the field instruments on the Tankbus, [Figure 3-7](#) illustrates how an instrument such as a pressure transmitter can be connected to the intrinsically safe 4 -20 mA analog input of the Rosemount 2410 Tank Hub.

Figure 3-7: Example of a System with Devices Connected to a Rosemount 2410 on a Single Tank

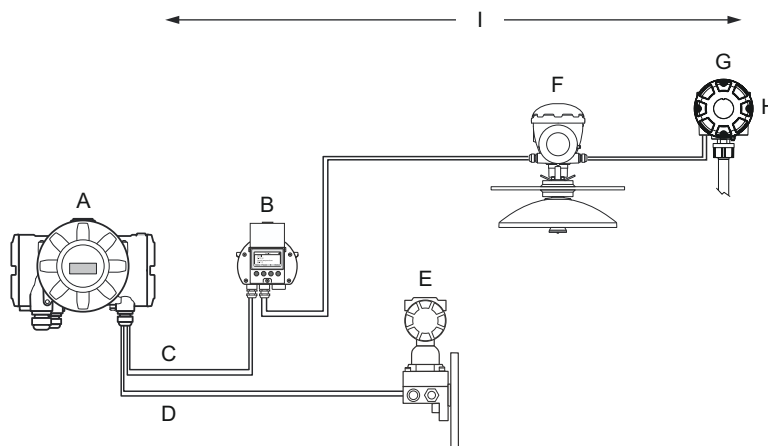

- A. Rosemount 2410 Tank Hub
- B. Rosemount 2230 Graphical Display
- C. Tankbus
- D. IS Analog Input (Secondary bus)
- E. Rosemount 3051S Pressure Transmitter
- F. Rosemount 5900S Radar Level Gauge
- G. Rosemount 2240S Multi-input Temperature Transmitter
- H. Built-in terminator enabled on the last device
- I. Tankbus length up to 1000 meter depending on number of devices and cable type

The Rosemount 2410 Tank Hub has a built-in terminator and intrinsically safe power supply with integrated power conditioner. The maximum distance between the Rosemount 2410 Tank Hub and the field devices depends on the number of devices connected to the Tankbus and cable type.

Maximum number of HART Slave devices:

- Passive current loop: 5
- Active current loop: 3

See [Cable selection for the Tankbus](#) and [Tankbus](#) for more information about cable selection and the Tankbus.

Non I.S. current loop alternative options:

1. Passive current loop. Input voltage range: 10.5 - 35 V
2. Active current loop. Output voltage range: 12.8 - 24 V @ 21.75 - 0 mA.

I.S. current loop alternative options:

1. Passive current loop. Input voltage range: 10.5 - 30 V
2. Active current loop. Output voltage range: 6.2 - 23 V @ 21.75 - 0 mA.

Note polarity for connection of polarity sensitive buses and I/O (for example RS485 and analog I/O).

See [Intrinsically safe terminal block](#) for information on the Intrinsically Safe terminal block.

See [Specifications and reference data](#) for more information on electrical characteristics for analog input and output.

2-in-1 version of the Rosemount 5900S in a SIL safety installation

Figure 3-8 illustrates an example with a 2-in-1 version of the Rosemount 5900S in a SIL safety installation. A 4-wire cable is used to connect the Primary and Secondary Tankbuses through the same cable entry. The SIL alarm wire is connected through a separate cable entry. A junction box provides sufficient number of connections for the field devices to the Primary and Secondary Tankbus.

Primary Tank Hub is connected to the electronic unit of the 5900S 2-in-1 level gauge for SIL overfill alarm.

Secondary Tank Hub is connected to the 5900S electronic unit used for level measurements.

Figure 3-8: SIL System with a Rosemount 5900S 2-in-1 dual bus connection

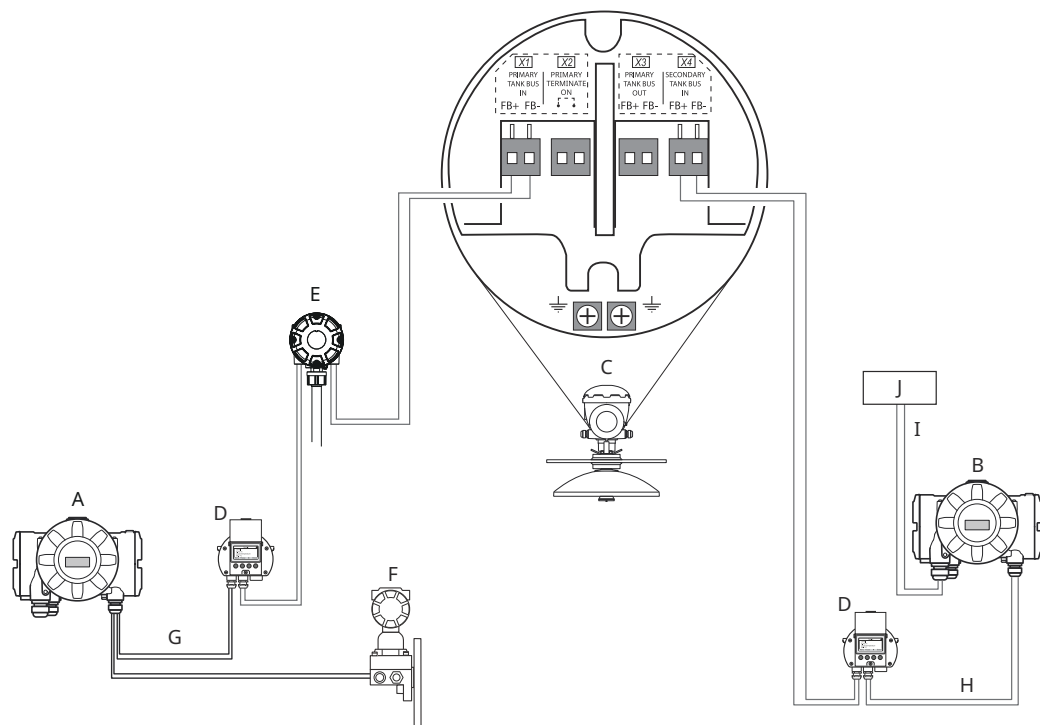

- A. Primary Rosemount 2410
- B. Secondary Rosemount 2410
- C. Rosemount 5900S Radar Level Gauge
- D. Rosemount 2230
- E. Rosemount 2240S Temperature Transmitter
- F. Pressure transmitter
- G. Primary Tankbus
- H. Secondary Tankbus
- I. SIL 2 relay (K1/2) or SIL 2 analog 4-20 mA output
- J. Emergency Shut Down system (ESD)

Rosemount 2410 Tank Hub connected to several field devices at the end of the Tankbus (fieldbus segment)

Figure 3-9 illustrates an example with four tanks connected to a Rosemount 2410 Tank Hub (requires Rosemount 2410 with multiple tanks option). The field devices are connected to a segment coupler at the end of the Tankbus.

A separate bus terminator is not required if one of the field devices with built-in terminator is connected at the end of the fieldbus segment. There are other options available as well, for example using a separate terminator plugged into the segment coupler, or a segment coupler with integrated bus terminator.

Figure 3-9: Example of a Rosemount Tank Gauging System with a Rosemount 2410 Tank Hub Connected to Several Field Devices at the end of the Tankbus (Fieldbus Segment)

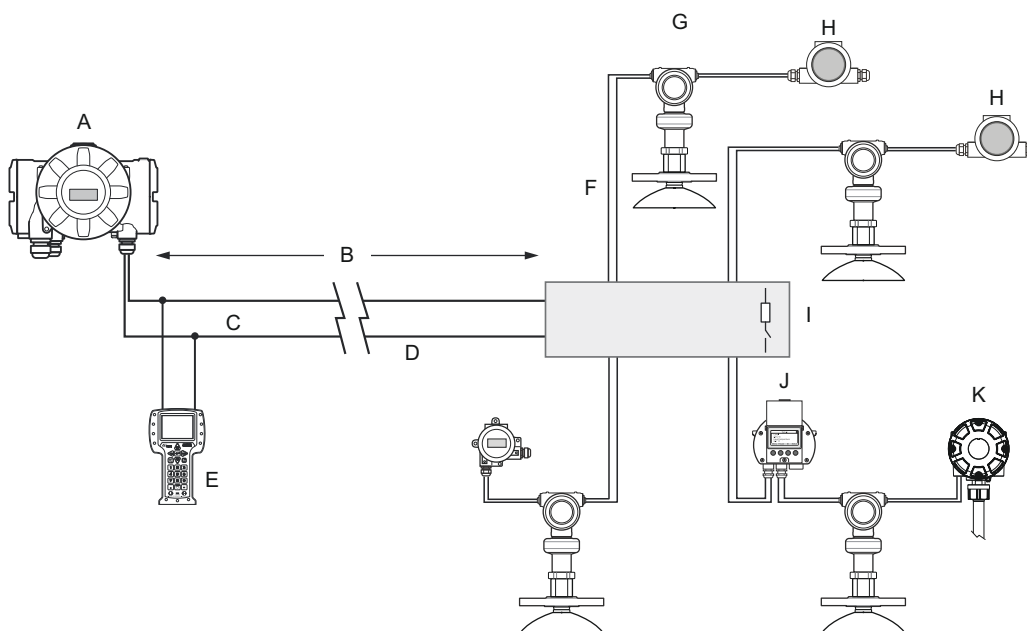

- A. Rosemount 2410 Tank Hub
- B. Tankbus length up to 1000 meter depending on number of devices and cable type
- C. Tankbus
- D. (Trunk)
- E. Field Communicator
- F. (Spurs <60 m)
- G. Rosemount 5408 Level Transmitter
- H. Rosemount 3144P Temperature Transmitter
- I. Segment coupler with integrated bus terminator
- J. Rosemount 2230 Display
- K. Rosemount 2240S Temperature Transmitter

The Rosemount 2410 Tank Hub has a built-in terminator and intrinsically safe power supply with integrated power conditioner.

Note that the total length of the Tankbus (fieldbus segment) must be within the FISCO specifications and the spurs must not exceed 60 meter, see [Cable selection for the Tankbus](#).

Several tanks daisy-chained to a Rosemount 2410

Figure 3-10 illustrates an example with a number of field devices daisy-chained to a Rosemount 2410 Tank Hub (requires multiple tanks option).

If a field device is connected to the end of the Tankbus (fieldbus segment), the built-in terminator can be used. Another option is to use a separate bus terminator.

Figure 3-10: Example of a Rosemount Tank Gauging system with several tanks daisy-chained to a Rosemount 2410

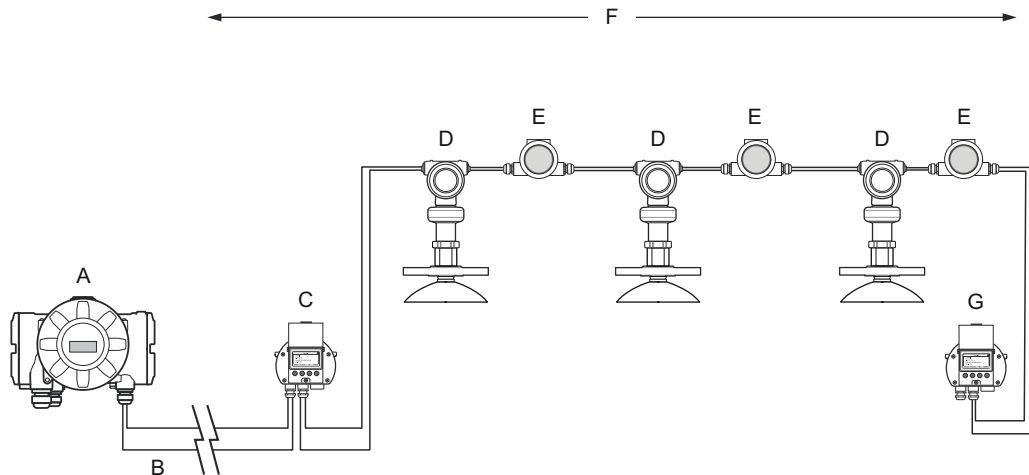

- A. Rosemount 2410 Tank Hub
- B. Tankbus
- C. Rosemount 2230 Display
- D. Rosemount 5408 Level Transmitter
- E. Rosemount 3144P Temperature Transmitter
- F. Tankbus length up to 1000 meter depending on number of devices and cable type
- G. Rosemount 2230 Display with built-in terminator

The Rosemount 2410 Tank Hub has a built-in terminator and intrinsically safe power supply with integrated power conditioner.

Note that the total length of the Tankbus (fieldbus segment) must be within the FISCO specifications, see [Cable selection for the Tankbus](#).

Three tanks connected to the Tankbus via segment couplers

Figure 3-11 illustrates an example with three tanks connected to a Rosemount 2410 Tank Hub (requires multiple tanks option). For each tank the field devices are connected to the Tankbus via a segment coupler.

The fieldbus segment needs to be terminated at both ends. A terminator is enabled in the Rosemount 2410 Tank Hub. At the end of the fieldbus segment you may use the built-in terminator in one of the field devices, or an external terminator plugged into one of the devices, or a segment coupler with integrated bus terminator.

Figure 3-11: Rosemount Tank Gauging system with three tanks connected to the Tankbus via segment couplers

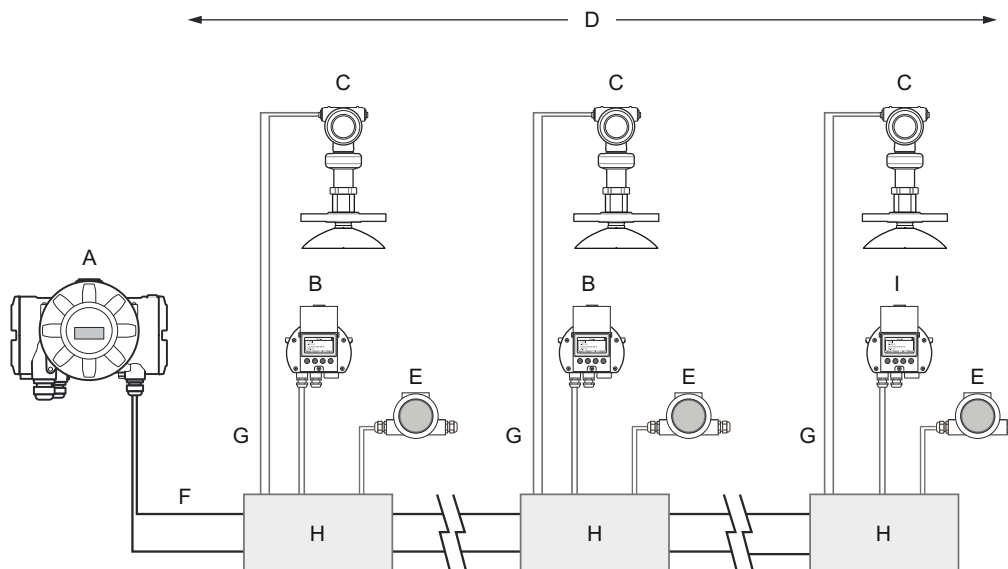

- A. Rosemount 2410 Tank Hub
- B. Rosemount 2230
- C. Rosemount 5408 Level Transmitter
- D. Tankbus length up to 1000 meter depending on number of devices and cable type
- E. Rosemount 3144P Temperature Transmitter
- F. Tankbus
- G. (Spur <60 m)
- H. Segment coupler
- I. Rosemount 2230 Display with built-in terminator

The Rosemount 2410 Tank Hub has a built-in terminator and intrinsically safe power supply with integrated power conditioner.

Note that the total length of the Tankbus (fieldbus segment) must be within the FISCO specifications and the spurs must not exceed 60 meter, see [Cable selection for the Tankbus](#).

Rosemount Tank Gauging system with external terminator

In case the last device on the Tankbus has no internal terminator, an external terminator⁽¹¹⁾ according to FISCO model and Entity model can be used instead. It can be screwed into a free cable gland on the device.

Figure 3-12: Example of Rosemount Tank Gauging System with External Terminator

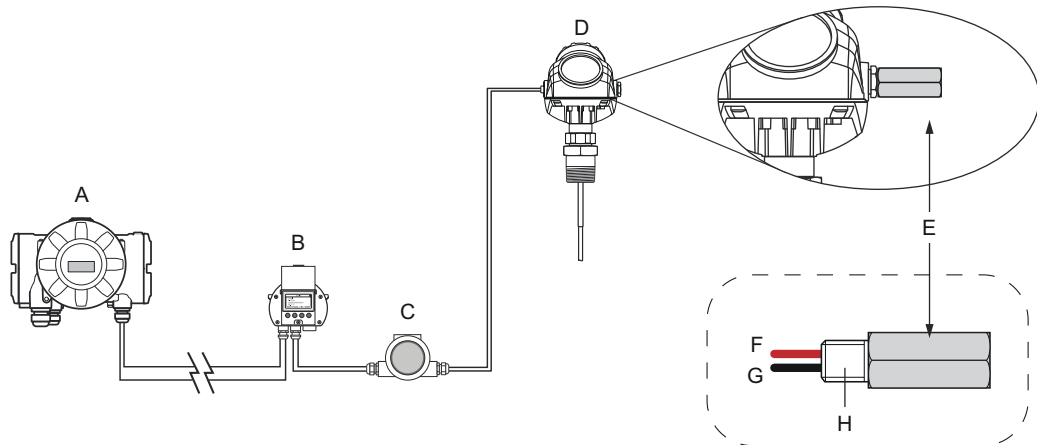

- A. Rosemount 2410 Tank Hub with intrinsically safe power supply, integrated power conditioner, and built-in terminator
- B. Rosemount 2230 Display
- C. Rosemount 3144P Temperature Transmitter
- D. Rosemount 5300 Level Transmitter
- E. External terminator
- F. Red+
- G. Black-
- H. 1/2 inch NPT

Related information

[Tankbus](#)

[Cable selection for the Tankbus](#)

(11) Part no. 6853511-494. Contact Emerson Automation Solutions/Rosemount Tank Gauging for more information.

3.4.9 Cabling for the TRL2/RS485 Bus

A standard Rosemount Tank Gauging system includes one or several Rosemount 2410 Tank Hubs communicating with a Rosemount 2460 System Hub using the TRL2/RS485 Modbus protocol.

TRL2 Bus

The TRL2 bus requires twisted and shielded pair wiring with a minimum cross-sectional area of 0.50 mm² (AWG 20 or similar). The maximum length of the TRL2 bus is approximately 4 km /13000 ft. The TRL2 field bus can normally use existing cables in the tank area.

Cable cross-sectional area for the TRL2 wiring should follow the recommendations in [Table 3-5](#).

Table 3-5: Minimum Cable Area for the TRL2 Bus

Maximum distance	Minimum cross-sectional area
3 km	0.50 mm ² (AWG 20)
4 km	0.75 mm ² (AWG 18)

Note

Wherever two or more TRL2 buses run alongside each other, sharing the same cable or conduit tube, use twisted and shielded wire and ensure that each pair of bus wires is individually shielded in order to avoid crosstalk.

Figure 3-13: Individually Shielded Pair Cables Minimizes Crosstalk

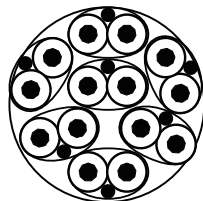

[Table 3-6](#) shows typical cable types that can be used for connecting the TRL2 bus. Other cables of similar type may also be used.

Table 3-6: Recommended Cable Standards for the TRL2 Bus

Type	Manufacturing standard	Core size
Signal	BS 5308 part 1, type 1	1 mm ²
Signal (armoured)	BS 5308 part 2, type 1	1 mm ²

RS485 Bus

The RS485 bus should meet the following requirements:

- twisted and shielded pair wiring
- characteristic impedance of 120 Ω
- maximum cable length 1200 m / 4000 ft.

Related information

[Communication](#)

3.4.10 Non-IS compartment wiring

The non-IS explosion-proof/flameproof compartment has a terminal block for connecting power supply, communication buses to host systems, relay outputs, and HART® 4-20 mA analog input and output.

Prerequisites

Note

Ensure that o-rings and seats are in good condition prior to mounting the cover in order to maintain the specified level of ingress protection. The same requirements apply for cable inlets and outlets (or plugs). Cables must be properly attached to the cable glands.

Procedure

1. ⚠ Ensure that the power supply is switched off.
2. Ensure that the cover jam screw (F) (see [Figure 3-14](#)) is completely threaded into the housing. It is intended to disallow the removal of the transmitter cover in flameproof environments without the use of tooling. The cover jam screw is threaded into the housing at factory.
3. Remove the cover on the non-IS terminal compartment.
4. Run the wires through the cable gland/conduit. Install wiring with a drip loop in such a way that the lower part of the loop is under the cable/conduit entry.
5. Connect wires to the terminal block. See [Table 3-8](#) for information on the terminal block connections.
6. Use the enclosed metal plug to seal any unused port.
7. ⚠ Tighten the conduits/cable glands.
8. ⚠ The cover on the terminal compartment should be tightened to mechanical stop (metal to metal). Make sure the cover is fully engaged to meet explosion-proof requirement and to prevent water from entering the terminal compartment.
9. Loosen the cover jam screw until it contacts the cover. Turn the jam screw an additional 1/2 turn counterclockwise to secure the cover.

Note

Application of excessive torque may strip the threads.

10. Verify that the cover cannot be removed.

Figure 3-14: Non-IS Terminal Compartment

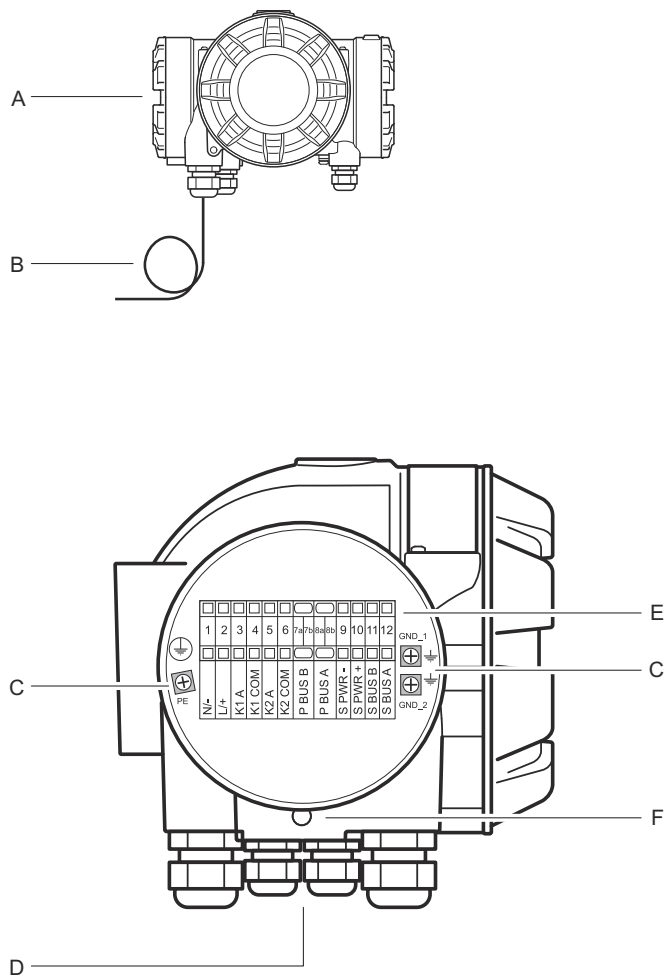

- A. Non-IS compartment
- B. Wiring with drip loop
- C. Ground screws
- D. Cable entries
- E. Terminal block
- F. Cover jam screw

Conductor recommendations

Ensure that you use cables suitable for the terminal block of the Rosemount 2410. The terminal block is designed for cables that meet the specifications as illustrated in [Figure 3-15](#).

Figure 3-15: Conductor and Insulation Requirements

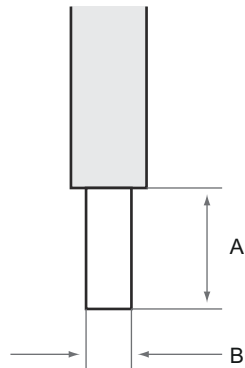

A. Stripping length: 10 mm

B. Conductor cross-sectional area, see [Table 3-7](#)

Table 3-7: Terminal Connection for Details for End User

Type	Rated (V)	Rated (A)	Strip length (mm)	Solid wire size (mm ²)	Stranded wire size (mm ²)	Flexible wire size (mm ²)	Clamping range (mm ²)	Resistance (MΩ)
ZDUB 2.5-2	550	21	10	0.5 - 4	0.5 - 2.5	0.5 - 2.5	0.13 - 4	1.33

No other wire sizes or types than the ones specified in instructions must be used. The terminal blocks must either be mounted next to another block of the same type and size or with an end plate.

Manually cut cross connections and cross connections with blank ends (ZQV's >=20 poles) shall not be used.

Connect the conductor to the terminal block

Procedure

Use a screw driver to insert the conductor into the terminal block as illustrated in [Figure 3-16](#)

Figure 3-16: Connecting the Conductor to the Terminal Block

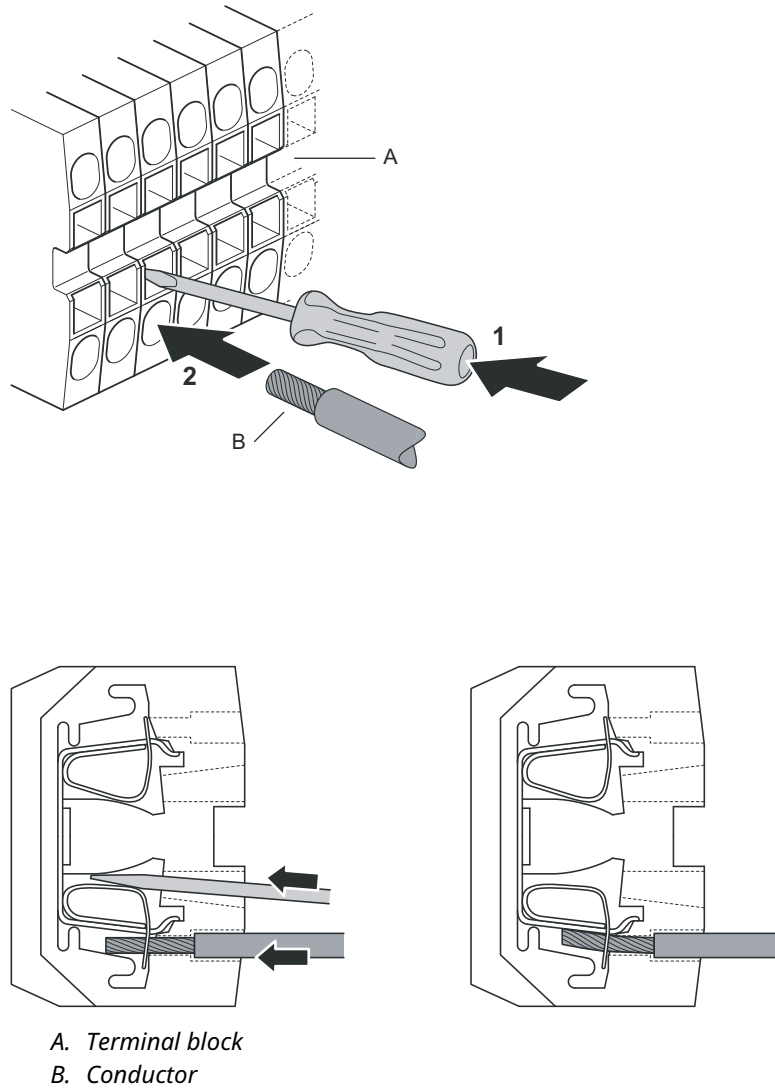

3.4.11 Non-IS terminal block

Figure 3-17: Terminal Block in the Explosion-proof/flameproof Compartment

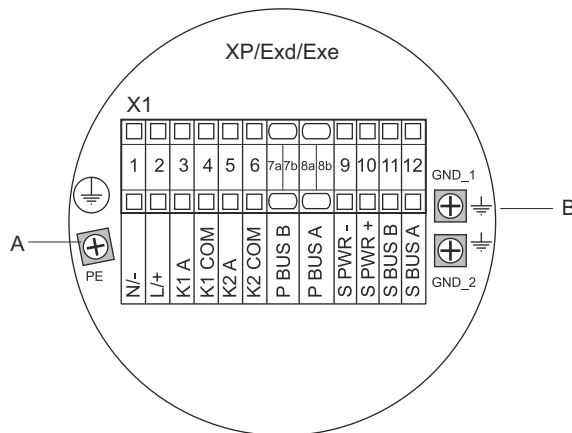

- A. Ground screw
- B. Ground screws for communication bus shields

Table 3-8: Terminal Assignment for Non-intrinsically Safe Side (XP/Exd/Exe)

Terminal	Designation	Function
1	N / -	Power, Neutral / DC -
2	L / +	Power, Line / DC +
3	K1 A ⁽¹⁾	Relay 1 output (optional). Hardware configurable NO/NC.
4	K1 com	Relay 1 common
5	K2 A	Relay 2 output (optional). Hardware configurable NO/NC.
6	K2 com	Relay 2 common
7a/7b	P Bus B	Primary communication bus
8a/8b	P Bus A	
9	S Pwr -	Secondary bus power - (optional)
10	S Pwr +	Secondary bus power + (optional)
11	S Bus B	Secondary communication bus - (optional)
12	S Bus A	Secondary communication bus + (optional)
PE	PE	Power supply protective ground
GND_1	GND_1	Housing chassis/shield Primary bus
GND_2	GND_2	Housing chassis/shield Secondary bus

(1) K1/K2 are SIL 2 rated (option code "S")

Power supply

The Rosemount 2410 accepts supply voltage 24-48 Vdc and 48-240 Vac (50/60 Hz).

Primary communication bus

In a standard configuration the Rosemount 2410 communicates with a host or a Rosemount 2460 System Hub via TRL2 Modbus or RS-485 Modbus protocol.

Secondary communication bus

The secondary bus can be used for communication using a number of protocols such as TRL2 Modbus, HART 4-20 mA, Enraf, Varec and L&J.

Relay outputs

There are two optional relay outputs. You can choose Normally Open (NO) or Normally Closed (NC) by setting a switch. See [Relay output configuration](#) for more information.

NO and NC refers to the contact position when a relay is deenergized. This is also referred to as the Alarm state. The terminology can be summarized as follows:

Table 3-9: Designation of Relay Contact Positions

Normally Closed (NC)		Normally Open (NO)	
Deenergized	Energized	Deenergized	Energized
Closed	Open	Open	Closed
Not active	Active	Not active	Active
Alarm (Reset)	Normal	Alarm (Reset)	Normal

Note

Ensure that maximum current through the relays does not exceed the specifications in [Specifications and reference data](#).

Related information

[Relay output configuration](#)

[Configure a virtual relay output](#)

Non-IS terminal block for SIL 3 safety systems

For **Safety Integrity Level 3** (SIL 3) systems the Rosemount 2410 has a terminal block on the Non-IS side with connection to a **SIL Alarm Relay** output.

Note

This terminal block is used for tank hubs ordered with Safety certification (SIS) model code 3.

Figure 3-18: Non-IS (XP/Exd/Exe) Terminal Block for SIL 3 Systems

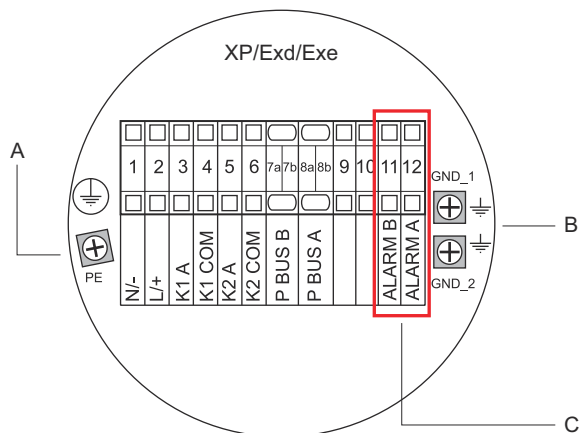

- A. Ground screw
- B. Ground screws
- C. SIL Relay

Table 3-10: Terminal Assignment for the SIL 3 Version of the Rosemount 2410 Non-IS Terminal Block

Terminal	Designation	Function
1	N / -	Power, Neutral / DC -
2	L / +	Power, Line / DC +
3	K1 A ⁽¹⁾	Relay 1 output (optional). Hardware configurable NO/NC.
4	K1 com	Relay 1 common
5	K2 A	Relay 2 output (optional). Hardware configurable NO/NC.
6	K2 com	Relay 2 common
7a/7b	P Bus B	Primary communication bus
8a/8b	P Bus A	
9		Not used
10		Not used
11	Alarm B	SIL Alarm Relay B
12	Alarm A	SIL Alarm Relay A
PE	PE	Protective power supply ground
GND_1	GND_1	Housing chassis/shield Primary bus

Table 3-10: Terminal Assignment for the SIL 3 Version of the Rosemount 2410 Non-IS Terminal Block (continued)

Terminal	Designation	Function
GND_2	GND_2	Housing chassis/shield Secondary bus

(1) K1/K2 are SIL 2 rated (option code "S")

3.4.12 IS compartment wiring

The IS compartment has a terminal block for connecting the intrinsically safe Tankbus for communication with field devices on the tank. This terminal block is also used for intrinsically safe HART 4-20 mA analog input/output communication.

Prerequisites

Note

Ensure that o-rings and seats are in good condition prior to mounting the cover in order to maintain the specified level of ingress protection. The same requirements apply for cable inlets and outlets (or plugs). Cables must be properly attached to the cable glands.

Procedure

1. ⚠ Make sure that the power supply is switched off.
2. Remove the cover on the IS terminal compartment.
3. Pull the cable through the cable gland/conduit. Install cables with a drip loop in such a way that the lower part of the loop is under the cable/conduit entry.
4. Connect wires according to [Table 3-11](#).
5. Use the enclosed metal plug to seal any unused port.
6. Tighten the conduit/cable gland.
7. ⚠ The cover on the terminal compartment should be tightened to mechanical stop (metal to metal). Make sure the cover is fully engaged to meet explosion-proof requirement and to prevent water from entering the terminal compartment.

Figure 3-19: IS terminal compartment

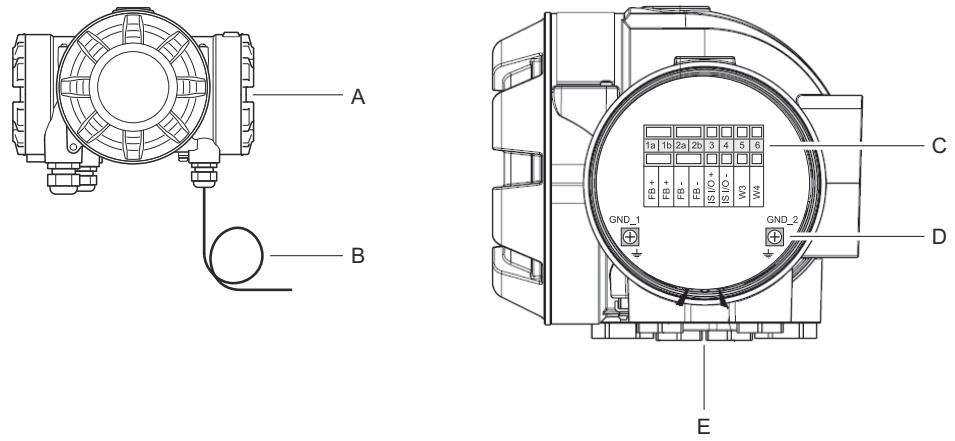

- A. IS compartment
- B. Wiring with drip loop
- C. Terminal block
- D. Ground screws
- E. Cable entries

3.4.13 Intrinsically safe terminal block

The Intrinsically safe side of the Rosemount 2410 Tank Hub connects to the Tankbus which communicates with field devices on the tank.

Figure 3-20: Intrinsically Safe (IS/Exi) Terminal Block

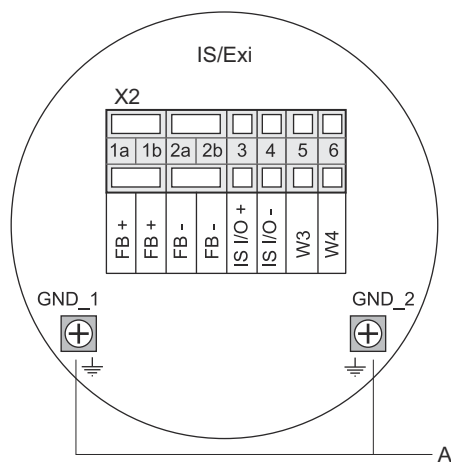

A. Ground screws

Table 3-11: Terminal Assignment for Intrinsically Safe Side

Terminal	Designation	Function
1a	FB +	Intrinsically Safe Tankbus positive (+) terminal
1b	FB +	Intrinsically Safe Tankbus positive (+) terminal
2a	FB -	Intrinsically Safe Tankbus negative (-) terminal
2b	FB -	Intrinsically Safe Tankbus negative (-) terminal
3	IS I/O+	IS Input/Output + HART / 4-20 mA (Secondary Bus)
4	IS I/O -	IS Input/Output - HART / 4-20 mA (Secondary Bus)
5	W3	Not used (future option)
6	W4	
GND_1	GND_1	Housing chassis/Tankbus shield
GND_2	GND_2	Housing chassis/Tankbus shield

Tankbus

The devices on the tank communicates with the Rosemount 2410 via the intrinsically safe Tankbus. All field devices in the Rosemount Tank Gauging system have built-in communication modems for FISCO FOUNDATION™ Fieldbus (FF) communication and will automatically communicate with the Rosemount 2410 when connected to the Tankbus.

Optional secondary bus

In addition to the Tankbus an optional intrinsically safe bus is available for communication with devices not compatible with FOUNDATION™ Fieldbus. It allows you to connect devices for intrinsically safe HART 4-20 mA analog input/output communication.

IS terminal block for SIL 3 safety systems

For Safety Integrity Level (SIL) systems the Rosemount 2410 has a terminal block with a SIL Alarm output for connection to a Rosemount 5900S Radar Level Gauge.

Note

This terminal block is used for tank hubs ordered with Safety certification (SIS) model code 3.

Figure 3-21: Intrinsically Safe (IS/Exi) Terminal Block for SIL 3 Systems

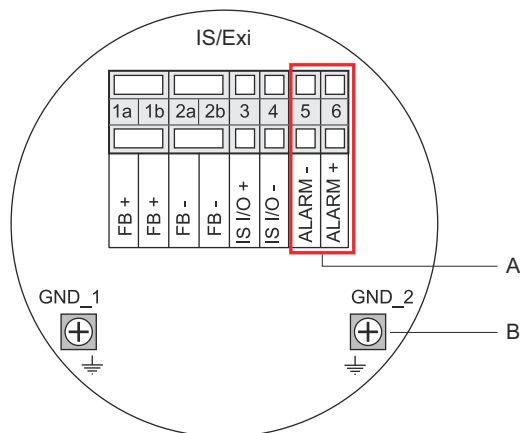

- A. SIL 3 Alarm
- B. Ground screws

Table 3-12: Terminal Assignment for the SIL 3 Version of the Rosemount 2410 Intrinsically Safe Terminal Block

Terminal	Designation	Function
1a	FB +	Intrinsically Safe Tankbus positive (+) terminal
1b	FB +	Intrinsically Safe Tankbus positive (+) terminal
2a	FB -	Intrinsically Safe Tankbus negative (-) terminal
2b	FB -	Intrinsically Safe Tankbus negative (-) terminal
3	IS I/O+	IS Input/Output +
4	IS I/O -	IS Input/Output -
5	Alarm -	SIL Alarm input - (connect to terminal block on Rosemount 5900S)
6	Alarm +	SIL Alarm input+ (connect to terminal block on Rosemount 5900S)
GND_1	GND_1	Housing chassis/Tankbus shield
GND_2	GND_2	Housing chassis/Tankbus shield

3.4.14 Wiring diagrams

Figure 3-22: Wiring Diagram on the Intrinsically Safe (IS/Exi) Side

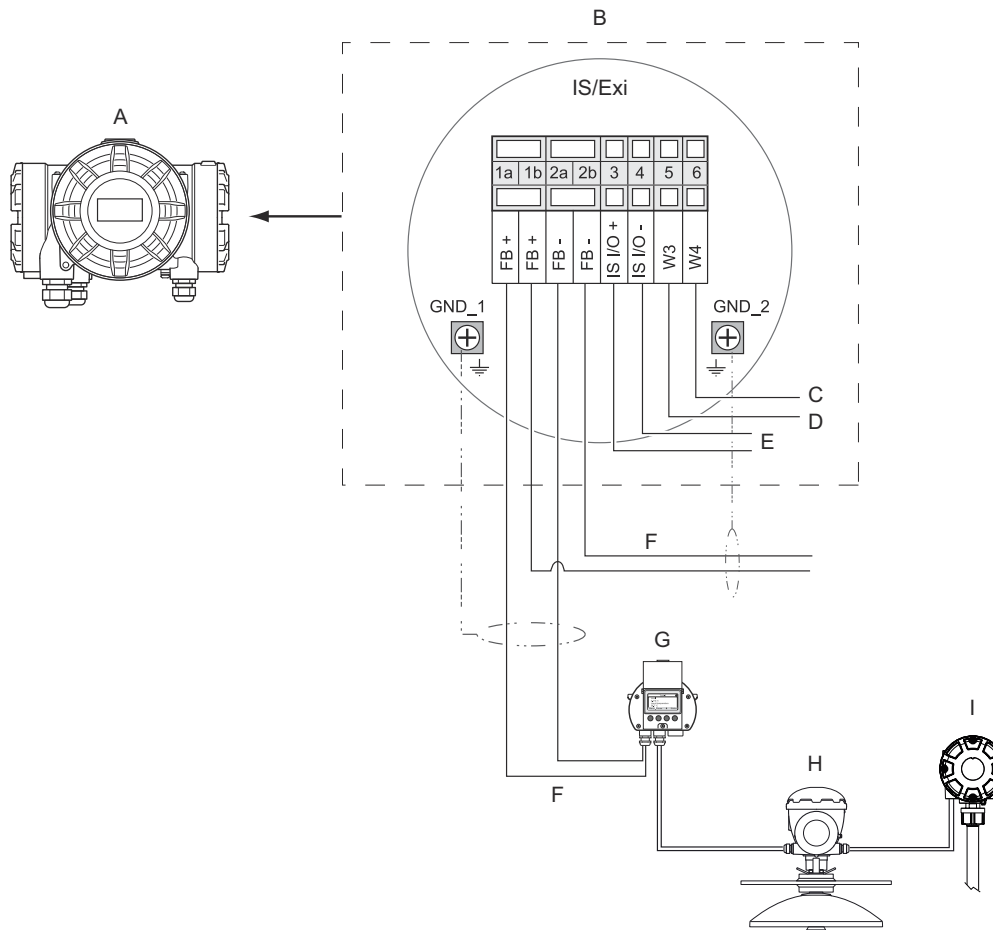

- A. Rosemount 2410
- B. Terminal block on intrinsically safe side
- C. Not used (future option)
- D. SIL systems: Alarm
- E. IS secondary bus
- F. Intrinsically safe Tankbus
- G. Rosemount 2230
- H. Rosemount 5900S
- I. Rosemount 2240S

Figure 3-23: Wiring Diagram on the Non-intrinsically Safe (XP/Exd/Exe) Side

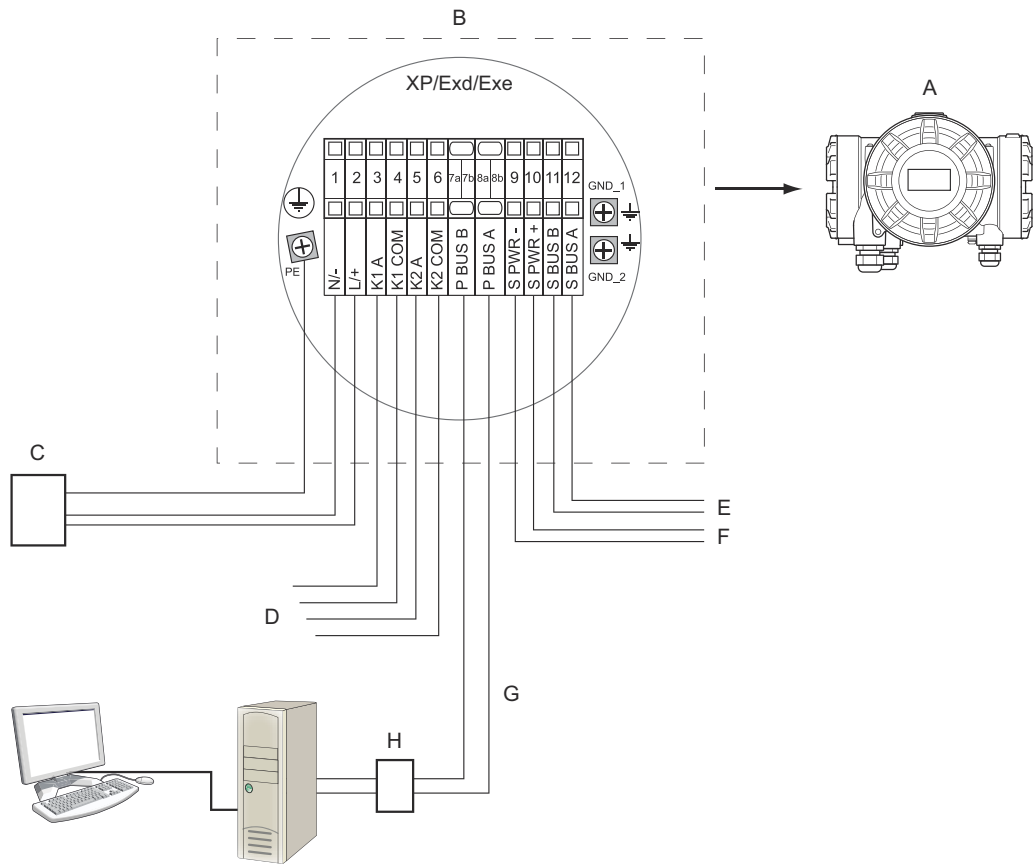

- A. Rosemount 2410
- B. Terminal block on Non-intrinsically safe side
- C. Power supply
- D. Relay outputs
- E. Secondary bus
- F. Secondary power
- G. Primary bus
- H. Modem

Figure 3-24: Wiring Diagram for Rosemount 2410 and Rosemount 5900S in a SIL Safety System

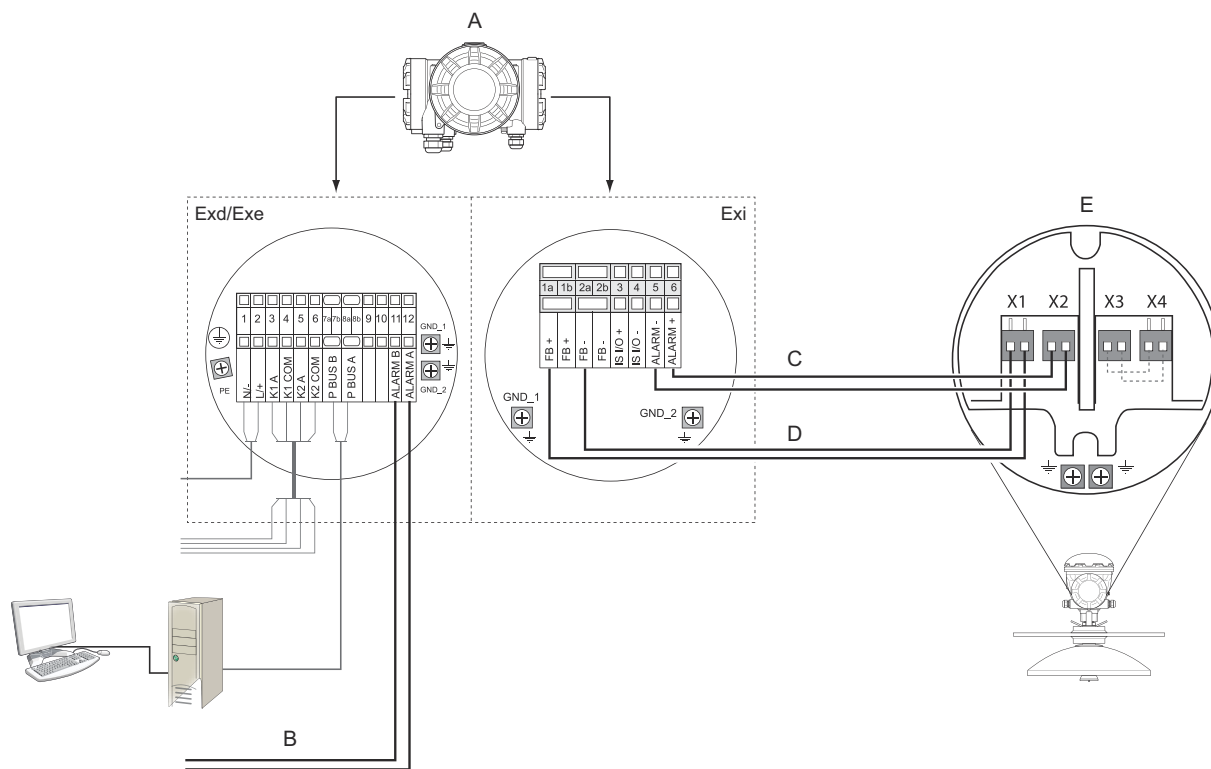

- A. Rosemount 2410 Tank Hub
- B. SIL Alarm Relay
- C. SIL Alarm Output
- D. Tankbus
- E. Rosemount 5900S Radar Level Gauge

4 Configuration

4.1 Safety messages

Instructions and procedures in this section may require special precautions to ensure the safety of the personnel performing the operations. Information that potentially raises safety issues is indicated by a warning symbol (⚠). Refer to the following safety messages before performing an operation preceded by this symbol.

⚠ WARNING

Failure to follow safe installation and servicing guidelines could result in death or serious injury.

Ensure only qualified personnel perform the installation.

Use the equipment only as specified in this manual. Failure to do so may impair the protection provided by the equipment.

Do not perform any services other than those contained in this manual unless you are qualified.

⚠ WARNING

Explosions could result in death or serious injury.

Verify that the operating atmosphere of the transmitter is consistent with the appropriate hazardous locations certifications.

Before connecting a handheld communicator in an explosive atmosphere, ensure that the instruments in the loop are installed in accordance with intrinsically safe or non-incendive field wiring practices.

Do not remove the gauge cover in explosive atmospheres when the circuit is alive.

4.2 Introduction

A Rosemount Tank Gauging system includes a wide range of devices for tank monitoring. It is a flexible and scalable system which can be adapted to various applications and small or large tank farms. A typical system includes one or more of the following devices:

- control room PC with Rosemount TankMaster program for operational control
- Rosemount 2460 System Hub that collects measurement data from Rosemount 2410 Tank Hubs
- Rosemount 2410 Tank Hub which collects measurement data from field devices on the tanks
- various field instruments such as the Rosemount 5900S Radar Level Gauge, Rosemount 2240S Multi-input Temperature Transmitter, Rosemount 2230 Graphical Field Display, Rosemount 3051S Pressure Transmitter
- Emerson Wireless Gateway and Emerson Wireless THUM Adapter for wireless communication between field devices and control room host system

See the Rosemount Tank Gauging [System Data Sheet](#) for a comprehensive description of the components in a Rosemount Tank Gauging system.

4.3 Configuration tools

The Rosemount 2410 Tank Hub is configured by using the Rosemount TankMaster WinSetup configuration program. WinSetup is a user-friendly software package that includes basic configuration options as well as advanced configuration and service functions.

See **Related information** for tips on sections and documents with more information.

Related information

[Configuration using TankMaster WinSetup](#)

[Rosemount Tank Gauging System Configuration Manual](#)

[Rosemount Wireless Tank Gauging System Reference Manual](#)

4.4 Basic configuration of a Rosemount 2410 Tank Hub

This is a general description of how to configure a Rosemount 2410 Tank Hub. The Rosemount Tank Gauging [System Configuration Manual](#) provides a detailed description of how to use the Rosemount TankMaster WinSetup program as a configuration tool for the Rosemount 2410.

Communication

Depending on the particular system configuration, a Rosemount 2410 Tank Hub may communicate directly with a host computer or via a Rosemount 2460 System Hub.

In case the Rosemount 2410 is connected to a Rosemount 2460 System Hub, you will have to specify which communication protocol channel to be used.

The Rosemount 2410 has default Modbus® address=247. The address should be changed to the recommended address range. The Modbus address must match the address specified in the Rosemount 2460's tank database.

The Rosemount 2410 Tank Hub can be used in a *WirelessHART* system by connecting an Emerson Wireless THUM™ Adapter. The THUM adapter allows the Rosemount 2410 to communicate with a host system via an Emerson Wireless Gateway.

Tank database

The Rosemount 2410 has a tank database that maps field devices to tanks. It also stores Modbus addresses of level gauges and auxiliary tank devices (ATD) such as the Rosemount 2240S Multi-input Temperature Transmitter. The Modbus addresses are used for communication with Rosemount 2460 System Hub and host computers.

Device tags

For each tank, device tags are specified for the level gauge and the auxiliary tank devices (ATD). ATD devices include all instruments on the tank except the level gauge. Device tags are used as identifiers in TankMaster.

Integral display

The Rosemount 2410 can be configured to present measurement data on the optional integral display. The display alternates between the selected items at a rate given by the Display Toggle Time parameter.

Measurement data such as Level, Level Rate, Free Water Level and many other tank variables can be displayed.

Measurement units for Level, Level Rate, Volume, Temperature, Density, and Pressure can be specified regardless of which units are used for presentation in, for example, the TankMaster programs.

4.5 Advanced configuration

The installation wizard in TankMaster Winsetup comprises a basic configuration of the Rosemount 2410. There are more options available in case further configuration is needed:

- Primary/Secondary Bus configuration
- Up to ten “virtual” Relay Functions
- Hybrid Density
- Delta Level
- Analog Output
- Analog Input / HART Slave⁽¹²⁾

Related information

[Advanced configuration](#)

4.6 Configuration using TankMaster WinSetup

A Rosemount 2410 Tank Hub can easily be installed and configured by using the TankMaster Winsetup configuration program. The WinSetup installation wizard guides you through the basic configuration of a Rosemount 2410.

See **Related information** for tips on sections and documents with more information.

Related information

[Rosemount Tank Gauging System Configuration Manual](#)

[Rosemount Wireless Tank Gauging System Reference Manual](#)

4.6.1 Installation wizard

The TankMaster WinSetup wizard is the recommended tool for installing the Rosemount 2410 and supports basic configuration. To start the installation wizard:

Procedure

1. In the WinSetup workspace select the **Devices** folder.

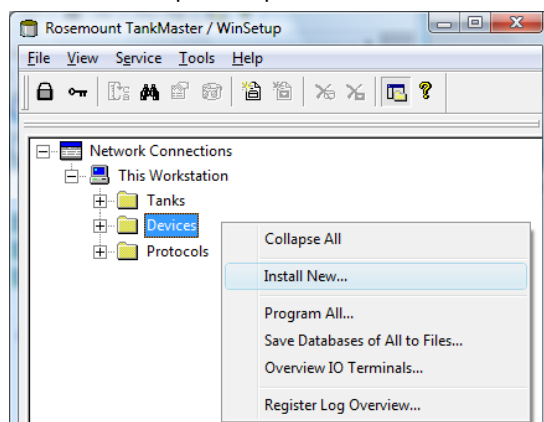

(12) Analog Input and HART Slave functions are configured in the Properties window of Auxiliary Tank Device (ATD), see [Configuration of analog input / HART® slave device](#).

2. Right-click and select **Install New**, or from the menu bar select **Devices** → **Install New**.
3. Choose device type Rosemount 2410 Tank Hub.
4. Follow the instructions in the installation wizard.

Need help?

See the Rosemount Tank Gauging [System Configuration Manual](#) for more information on using the TankMaster WinSetup program to configure the Rosemount 2410.

4.6.2 Advanced configuration

Advanced options such as the Secondary Bus, Relay Output and Hybrid Density are available in the **Rosemount 2410 Properties** window.

Related information

[Advanced configuration](#)

4.6.3 Installing a Rosemount 2460 System Hub

In case the Rosemount Tank Gauging system includes a Rosemount 2460 System Hub, it should be installed prior to installing the Rosemount 2410 Tank Hub. Installation includes the following basic steps:

Prerequisites

Ensure that the Rosemount TankMaster WinSetup program is up and running.

Procedure

1. Enable and configure a Protocol Channel in order to establish communication with the appropriate port on the TankMaster PC.
2. Start the installation wizard in TankMaster WinSetup.
 - a) Right-click the **Devices** folder.
 - b) Select **Install new**.
3. Choose device type 2460 System Hub.

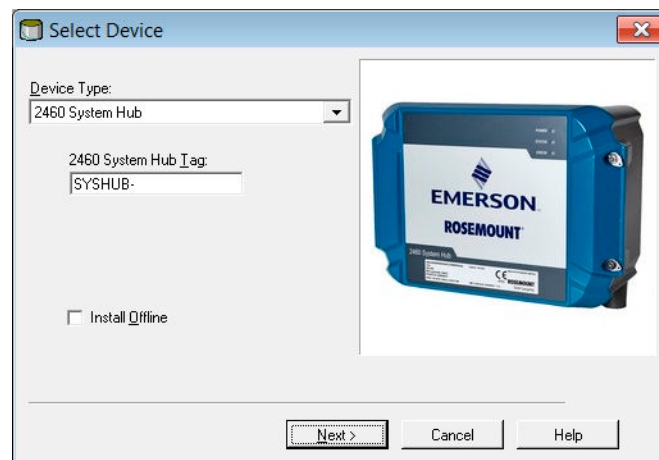

4. Specify a name tag in the 2460 System Hub Tag input field.

This tag will be used as an identifier of the system hub in various windows and dialogs.

5. Click the **Next** button to proceed with the installation wizard.
6. Verify communication with the host computer/TankMaster PC.
7. Verify that Host ports and Field ports are properly configured.
Host ports are used for communication with TankMaster work stations or other host systems. Field ports are used for communication with field devices such as the Rosemount 2410 Tank Hub, the Rosemount 5900S Radar Level Gauge, and others.
8. Configure the tank database. Ensure that Modbus Addresses of the connected devices are properly set. These addresses must correspond to the Rosemount 2410 Tank Hub database settings.

Need help?

See the Rosemount 2460 System Hub [Reference Manual](#) for more information.

5 Operation

5.1 Safety messages

Instructions and procedures in this section may require special precautions to ensure the safety of the personnel performing the operations. Information that potentially raises safety issues is indicated by a warning symbol () . Refer to the following safety messages before performing an operation preceded by this symbol.

WARNING

Failure to follow safe installation and servicing guidelines could result in death or serious injury.

Ensure only qualified personnel perform the installation.

Use the equipment only as specified in this manual. Failure to do so may impair the protection provided by the equipment.

Do not perform any services other than those contained in this manual unless you are qualified.

WARNING

Explosions could result in death or serious injury.

Verify that the operating atmosphere of the transmitter is consistent with the appropriate hazardous locations certifications.

Before connecting a handheld communicator in an explosive atmosphere, ensure that the instruments in the loop are installed in accordance with intrinsically safe or non-incendive field wiring practices.

Do not remove the gauge cover in explosive atmospheres when the circuit is alive.

5.2 Integral display

The Rosemount 2410 Tank Hub can be equipped with an optional integral display for presentation of measurement data and diagnostics. When the device is switched on, the display presents information such as device model, communication protocol (Modbus[®], Enraf, etc.) and address, relay configuration, software version, serial number, unit ID, and write protection status. See [Table 5-2](#) for more information on start-up information.

When the Rosemount 2410 is up and running the display presents Level, Signal Amplitude, Volume and other measurement variables depending on how the display is configured. The available parameters are listed in [Table 5-1](#).

The display has two rows for data presentation. The upper row shows tank name (up to six characters) and measurement values. The lower row shows variable type and measurement unit.

You can specify which variables to present on the display by using a configuration tool such as the Rosemount TankMaster WinSetup program.

The display toggles between different measurement values and units at a rate which can be configured by using the WinSetup program.

Figure 5-1: The Rosemount 2410 Integral Display

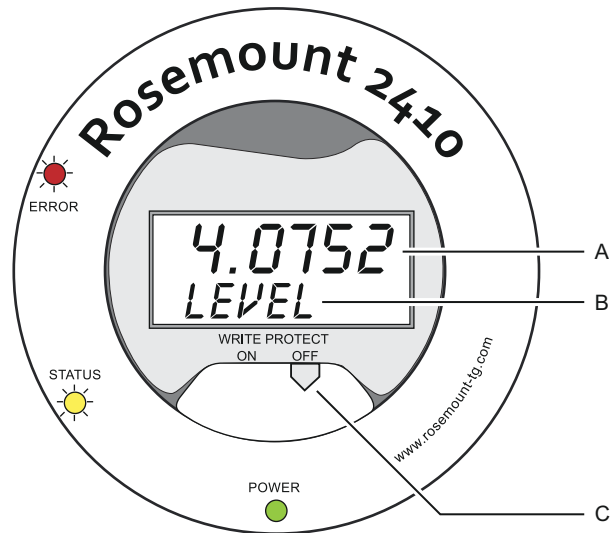

- A. Measurement value
- B. Toggling between measurement variable and measurement unit
- C. Write protection switch

Table 5-1: Measurement Variables and Presentation on the Rosemount 2410 Display

Variable	Presentation on display	Description
Level	LEVEL	Product level
Ullage	ULLAGE	Distance from the upper reference point to the product surface
Level Rate	LRATE	The speed of level movement up or down
Signal Strength	SIGN S	Signal amplitude of the surface echo
Free Water Level	FWL	Free water level at the bottom of the tank
Vapor Pressure	VAP P	Automatic or manual Vapor Pressure value
Liquid Pressure	LIQ P	Automatic or manual Liquid Pressure value
Air Pressure	AIR P	Automatic or manual Air Pressure value
Ambient Temperature	AMB T	Automatic or manual Ambient Temperature value
Vapor Average Temperature	VAP T	Average temperature of vapor above the product surface
Liquid Average Temperature	LIQ T	Average temperature for all spot sensors submersed in liquid
Tank Average Temperature	TANK T	Average value of all temperature sensors in the tank
Spot 1 Temperature	TEMP 1	Temperature value for spot sensor no. 1
Spot n Temperature	TEMP n	Temperature value for spot sensor no. "n"
Spot 16 Temperature	TEMP 16	Temperature value for spot sensor no. 16
Observed Density	OBS D	Automatic or manual Observed Density
Reference Density	REF D	Product density at standard reference temperature 15 °C (60 °F)
Volume	TOV	Total observed volume
Flow Rate	F RATE	Flow rate
User Defined 1	UDEF 1	Up to 5 user defined variables
Tank Height	TANK R	Distance from Tank Reference Point to Zero Level
Delta Level	ΔLVL	The difference between two level values

Related information

[Specifying display variables](#)

5.3 Start-up information

When the Rosemount 2410 starts up, all LCD segments light up for approximately 5 seconds. The start-up information appears on the display when the software initialization procedure is finished. The Primary Bus configuration appears first, followed by the Secondary Bus configuration. Each item appears a few seconds on the display:

Table 5-2: Start-up Information on the Rosemount 2410 Display

Item	Example
Model number and type (multiple / single tank version). Single tank version is required for Rosemount 2410:SIS.	Rosemount 2410 MULTI
Primary communication bus hardware option (TRL2, RS485, Enraf GPU, HART® master, HART slave, other emulation options)	PR HW RS-485 HART M HART S SIL AR
Primary communication bus protocol	PRI MODBUS
Primary Bus communication address	ADDR 247
Primary Bus communication settings (Baud rate, stop bits and parity)	9600 1 0
Secondary communication bus hardware option (TRL2, Enraf GPU, HART wireless, HART master, HART slave, other emulation options)	EN GPU HART W HART M HART S SIL AR
Secondary communication bus protocol	SEC ENRAF
Secondary Bus communication address	10
Secondary Bus communication settings (Baud rate, stop bits and parity)	1200 1 0
Software version	1.B1 SW
Serial number	SN 12 345678
Unit ID (when Modbus is available on Primary or Secondary bus)	UNID 23456
Write protection status (ON/OFF)	ON W PROT
Relay option	--K2 RELAY

5.4 Error codes

In addition to presenting measurement values, the display can show software and hardware error messages. In case of an error, the upper row shows "ERROR" and the lower row toggles between "FAIL" and the error code.

Figure 5-2: Error Codes can be Presented on the Rosemount 2410 Display

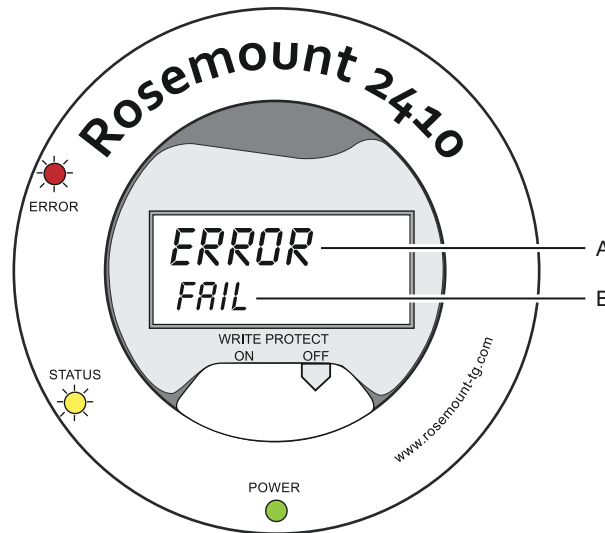

- A. "ERROR" indication
- B. Fail/Error code

The following error codes are used:

Table 5-3: List of Error Codes and Messages that may Appear on the Display

Code	Error
RAM	Ram failure
FPROM	FPROM
HREG	Holding register error
OMEM	Other memory error
SYS	System error
DPLY	Display error
AUX	AUX
FF ST	FF stack
TBUS	Tank Bus
HOST C	Host
D MNGR	Data manager
CFG	Invalid Configuration
SW	Software

Related information

[Error messages](#)

5.5 LED

There are three Light Emitting Diodes (LED) on the Rosemount 2410 front for status and error information.

Figure 5-3: The Rosemount 2410 has Three LEDs

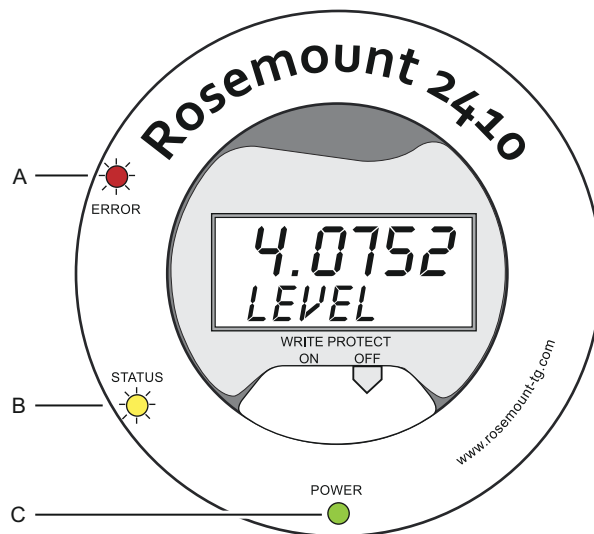

- A. Error LED (Red)
- B. Status LED (Yellow)
- C. Power On LED (Green)

The following color codes are used for the Rosemount 2410 LEDs:

Table 5-4: LED Color Codes

LED Type	Color	Description
Power On	Green	The green LED indicates that the Rosemount 2410 is powered on.
Status	Yellow	The yellow Status LED blinks at a constant rate of one flash every other second in normal operation to indicate the Rosemount 2410 software is running
Error	Red	The red Error LED is turned off in normal operation. If an error occurs, the Error LED flashes a sequence that corresponds to a certain error code.

Related information

[Error LED](#)

5.5.1 LED start-up information

When the Rosemount 2410 is starting, both the Status and the Error LEDs indicate possible hardware or software errors as shown in [Table 5-5](#):

Table 5-5: LEDs Are Used for Error Indication at Rosemount 2410 Start-up

Error type	Status LED	Error LED	Description
Hardware	Blinking	Blinking	Status and Error are blinking simultaneously
Checksum	Blinking	Blinking	Status and Error are toggling
Other	On	Blinking	Unknown error

5.5.2 Error LED

In normal operation the Error LED (Red) is turned off. In case a device error occurs, the LED will flash a sequence that corresponds to the error code followed by a five second pause.

Figure 5-4: Error Codes are Presented by the Error LED

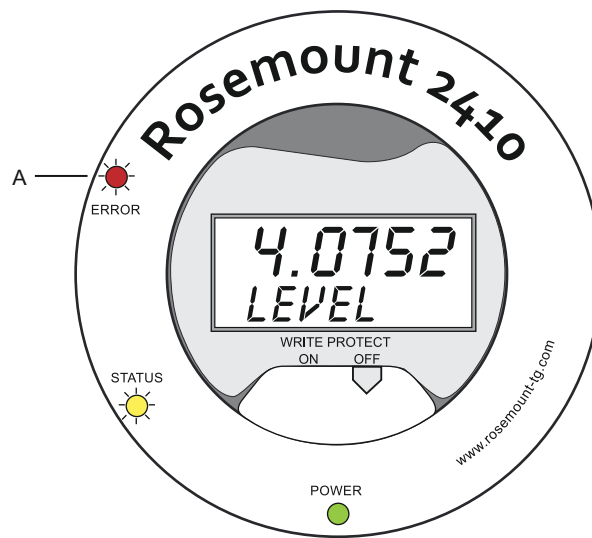

A. Error LED (Red)

The following errors codes may appear:

Table 5-6: LED Error Codes

Code	Error type
1	FEPROM
2	HREG
3	Software
4	Other memory error
5	System
6	Display
7	Aux
8	FF stack
9	Tankbus
10	Host communication
11	Data manager
12	Configuration

Example

In case of a device error, the red LED will repeat a flash sequence that corresponds to the particular type of error that occurred. For example, in case of a Display error (code=6), the LED will show a sequence of 6 flashes followed by a 5 seconds pause. After the pause the flashing starts over again in the same manner. This flash/pause sequence will be continuously repeated.

Display error (code 6) appears with the following Error LED (red) flash sequence as illustrated in [Figure 5-5](#):

Figure 5-5: Error Code Flash Sequence

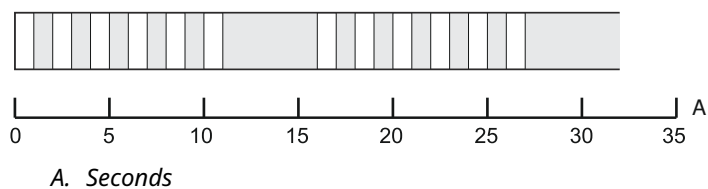

Related information

[Error messages](#)

5.6 Specifying display variables

The Rosemount 2410 can be configured to present measurement data on the optional integral display. Measurement data such as Level, Level Rate, Free Water Level and many other tank variables can be displayed.

Measurement units for Level, Volume, Temperature, Density, Pressure, and Weight can be specified.

The display will alternate between the selected items at a rate given by the **Display Toggle Time** parameter.

When the Rosemount 2410 is installed and configured, the display can easily be set up with the Rosemount TankMaster WinSetup program to show tanks and measurement variables. The current display settings can be changed at any time in the **Rosemount 2410 Local Display** window as shown below:

Procedure

1. In the **Rosemount TankMaster WinSetup** configuration program, right-click the Rosemount 2410 icon.
2. Choose the **Properties** option.
3. In the **Rosemount 2410 Tank Hub** window, select the **Local Display** tab.

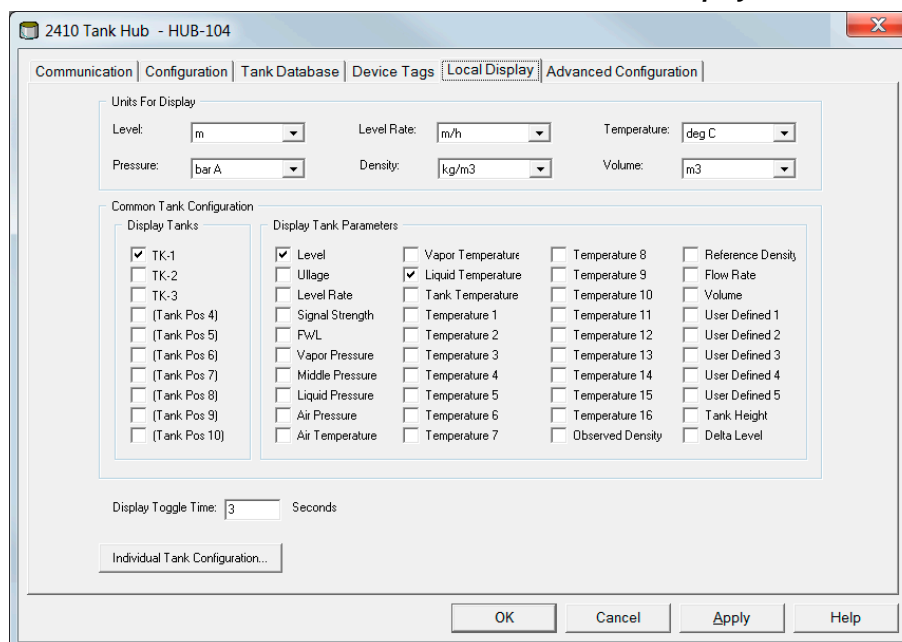

4. Select the desired tanks and tank parameters such as Level, Temperature, Vapor Pressure, or any other preferred tank parameter⁽¹³⁾.
5. Choose measurement units for the Rosemount 2410 integral display.

The first time the **Local Display** tab is opened, the same measurement units are used as specified in the TankMaster WinSetup **Server Preferences/Units** window.

⁽¹³⁾ Note that limited data is available for Rosemount 2410:SIS Tank Hub. This means that not all variables are displayed.

- Click the **Individual Tank Configuration** button in case you would like to specify different display settings for different tanks.

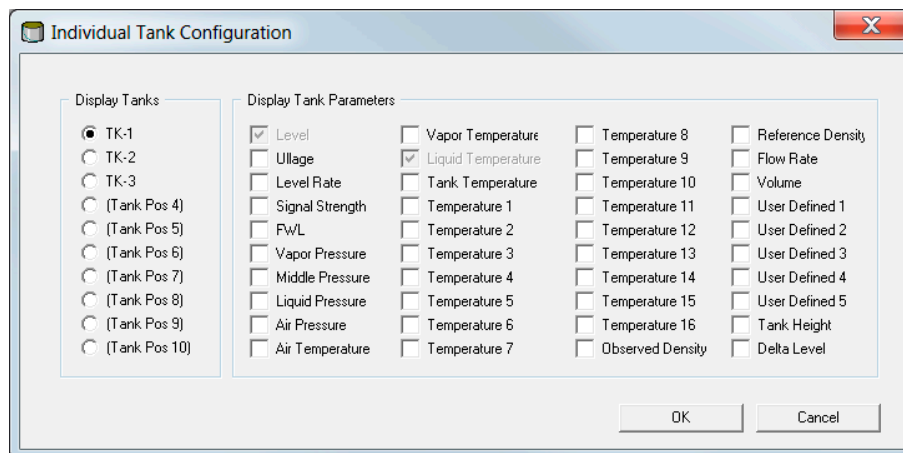

- Click the **OK** button to save the configuration and close the window.
- In the **Rosemount 2410 Tank Hub** window click the **OK** button to save the configuration and close the window.

Need help?

See the Rosemount Tank Gauging [System Configuration Manual](#) for more information on using the TankMaster WinSetup PC software to configure the Rosemount 2410 Tank Hub.

Related information

[Functional safety/SIS applications \(SIL 2 single tank\) version](#)

6 Service and troubleshooting

6.1 Safety messages

Instructions and procedures in this section may require special precautions to ensure the safety of the personnel performing the operations. Information that potentially raises safety issues is indicated by a warning symbol () . Refer to the following safety messages before performing an operation preceded by this symbol.

WARNING

Failure to follow safe installation and servicing guidelines could result in death or serious injury.

Ensure only qualified personnel perform the installation.

Use the equipment only as specified in this manual. Failure to do so may impair the protection provided by the equipment.

Do not perform any services other than those contained in this manual unless you are qualified.

WARNING

Explosions could result in death or serious injury.

Verify that the operating atmosphere of the transmitter is consistent with the appropriate hazardous locations certifications.

Before connecting a handheld communicator in an explosive atmosphere, ensure that the instruments in the loop are installed in accordance with intrinsically safe or non-incendive field wiring practices.

Do not remove the gauge cover in explosive atmospheres when the circuit is alive.

To prevent ignition of flammable or combustible atmospheres, disconnect power before servicing.

6.2 Service

This section briefly describes functions which may be useful for service and maintenance of a Rosemount 2410 Tank Hub. If not otherwise stated, most examples are based on using the TankMaster WinSetup tool to access these functions. The Rosemount TankMaster WinSetup [Reference Manual](#) and the Rosemount Tank Gauging [System Configuration Manual](#) provide more information on how to use the TankMaster WinSetup program.

6.2.1 Viewing input and holding registers using TankMaster™

In a Rosemount Tank Gauging system, measurement data is continuously stored in **Input Registers** of devices such as the Rosemount 2410 Tank Hub, Rosemount 5900 Radar Level Gauge, and others. By viewing the input registers of a device, you can verify that the device is working properly.

Holding Registers store various device parameters used to control measurement performance.

Procedure

1. Start the TankMaster WinSetup program.
2. In the **TankMaster WinSetup** workspace window, select the device icon.

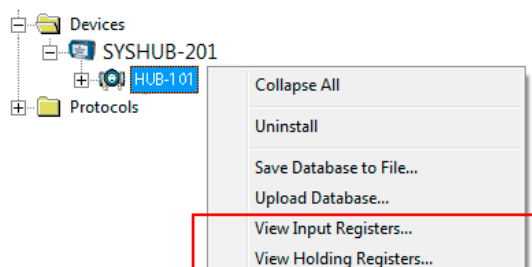

3. Right-click and select **View Input/View Holding Registers option**, or from the **Service** menu choose **Devices** → **View Input/View Holding Registers**. Now the View Input/Holding Register window appears.
4. In the **Registers Type** list, select **Predefined** or **All**.

Option	Description
Predefined	View a basic selection of registers.
All	View a range of registers by your own choice (for advanced service).

5. For the **All** option, you have to specify a range of registers by setting a start value in the **Start Register input** field, and the total number of registers to be displayed in the **Number of Registers** field (1-500). Up to 50 registers is recommended for a quick update of the list.

6. The **Registers Scope** drop-down list has three options:

Scope	Description	Access level
Basic	Standard setting that includes the most commonly used registers	View Only
Service	Includes a wider range of registers for advanced service and troubleshooting	Supervisor
Developer	For advanced users only	Administrator

7. In the **Show Values in** pane, choose the appropriate register format Decimal or Hexadecimal.
8. Click the **Read** button.
Now the **View Input/Holding Registers** window is updated with the current register values.

6.2.2 Editing holding registers using TankMaster™

Most Holding Registers can be edited simply by typing a new value in the appropriate Value input field. Some Holding Registers (marked grey in the Value column) can be edited in a separate window. In this case you can choose from a list of options or you can change separate data bits.

For more information see the Rosemount Tank Gauging [System Configuration Manual](#).

6.2.3 View the device live list in TankMaster™

The **Device Live List** lets you view devices connected to the Tankbus. You can, for example, see Device Id, Tag, and whether the devices are configured or not.

The **Device Live List** is useful when you are going to configure devices in a Rosemount Tank Gauging system, in order to verify that the required devices are connected to the Tankbus.

Procedure

1. Start the TankMaster WinSetup program.
2. In the **TankMaster WinSetup** workspace, select the Rosemount 2410 icon.
3. Right-click and select **Live List**.

Figure 6-1: The Device Live List Window

Device Type	Device Id	Manufact. Id	Device No	FF Address	Handled	Connected	Configured	Opened	Auto Mode	Tag
1	5900 RLG	0	Rosemount	1	232	Yes	Yes	Yes	Yes	5900-DEVICE-000000000
2	2240 TTM	16	Rosemount	2	245	Yes	Yes	Yes	Yes	Device-0011512240-EPM-0x00000010
3	No Device									
4	No Device									
5	No Device									
6	No Device									
7	No Device									
8	No Device									
9	No Device									
10	No Device									
11	No Device									
12	No Device									
13	No Device									
14	No Device									
15	No Device									
16	No Device									

Show Unit ID Show ""Device ID"" column As HEX Close

Device live list window

The Rosemount 2410 Tank Hub **Device Live List** window shows the following information:

Table 6-1: Device Live List Description

Item	Description
Device Type	Examples of supported devices: Rosemount 5900S, 2410, 2240S, 2230, 5300, 5408, 848T, and 3051S. For unknown devices the device type number is shown.
Device ID (Unit ID)	A unique code that identifies a particular device. You can choose to view the device ID in decimal or hex format depending on what format is supported by the device.
Manufact Id	Identifies the manufacturer.
Device No	Index used to identify devices by the FF stack.
FF Address	FOUNDATION™ Fieldbus address used for communication on the Tankbus.
Handled	Bit 0 of the Live List Status input register which indicates the current Tankbus communication status of the device.
Connected	“No” means that the device has been disconnected from the Tankbus.
Configured	“Yes” indicates that the device is configured in the Rosemount 2410 tank database, i.e. the device is mapped to a particular tank.
Opened	Bit 1 of the Live List Status input register which indicates the current Tankbus communication status of the device.
Auto Mode	“Yes” in normal operation. “No” indicates that the device is in Out of Service mode.
Tag	A removable tag provided with the device lets you identify the device to a physical location. This field shows the Tag number of the device (when available).

6.2.4 Backing up a device configuration using TankMaster™

Using Rosemount TankMaster WinSetup to save the current device configuration to file:

Procedure

1. Start the Rosemount TankMaster WinSetup program.
2. In the **TankMaster WinSetup** workspace window, right-click the device icon.
3. Choose the **Save Database to File** option.

This option is also available from the **Service/Devices** menu.

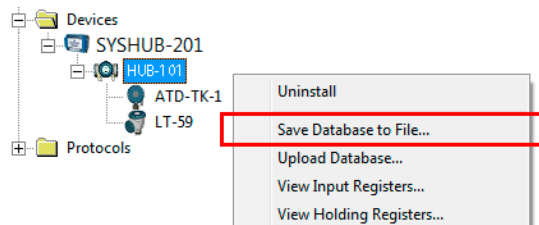

4. Choose the desired options for **Type of Registers**, **Predefined** or **User-defined**⁽¹⁴⁾, and **Scope**. Options may vary depending on device type.

⁽¹⁴⁾ User-Defined should only be used for advanced service.

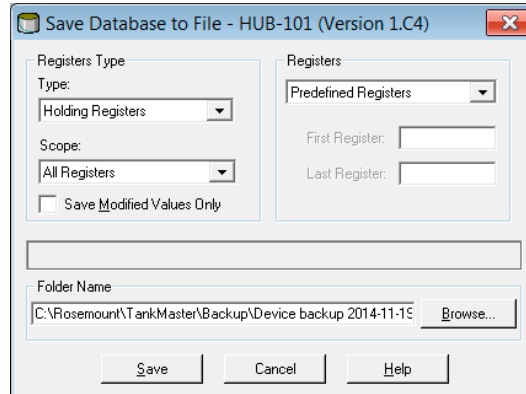

5. Click the **Browse** button, select a folder and type a name for the backup file.
6. Click the **Save** button to start saving the database registers.

6.2.5 Recover a backup configuration database using TankMaster™

Rosemount TankMaster WinSetup lets you replace the current Holding Register database with a backup database stored on disk. This can be useful, for example, if you want to recover lost configuration data.

Procedure

1. In the **TankMaster WinSetup** workspace window, select the device icon.
2. Right-click and select **Upload Database**, or from the **Service** menu choose **Devices/ Upload Database**.
3. Click the **Browse** button and choose a database file to be uploaded, or type a path and file name.
4. Click the **Upload** button.

6.2.6 View and configure diagnostic registers using TankMaster™

The Rosemount TankMaster WinSetup program lets you view the current device status. The **View Diagnostic Register** window shows a selection of database registers that gives you an instant view of how the gauge operates. You may also configure the window by adding registers of special interest.

Procedure

1. In the **TankMaster WinSetup** workspace window, right-click the device icon.

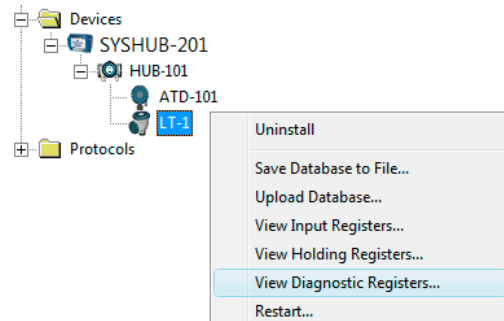

2. Right-click and select **View Diagnostic Registers**.

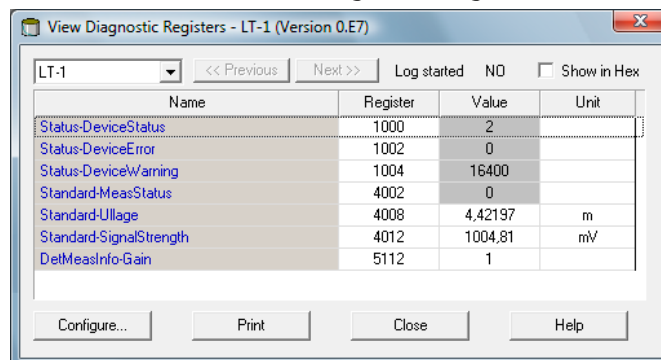

Diagnostics registers window

The register values in the diagnostics window are of read only type. They are loaded from the device as the window is opened.

A grey background color of the table cell in the Value column means that the register is of either Bitfield or ENUM type. An expanded Bitfield/ENUM window can be opened for this type of register. Double-click the cell to open the Expanded Bitfield/ENUM window.

If needed, the values can be presented as hexadecimal numbers. This applies to all registers of Bitfield and ENUM types. Select the **Show in Hex** check box to present Bitfield and ENUM registers as hexadecimal numbers.

The **Configure** button lets you open the *Configure Diagnostic Registers* window where you can change the list of registers to be displayed in the *View Diagnostic Registers* window. See the Rosemount Tank Gauging [System Configuration Manual](#) for more information.

The **Configure Diagnostic Registers** window also has a **Log Setup** button for access to the **Register Log Scheduling** window which allows you to setup a log schedule for automatic start and stop of register logging.

Related information

[Logging measurement data using TankMaster](#)

6.2.7 Upgrading the device firmware using TankMaster™

Rosemount TankMaster WinSetup includes the option to upgrade the Rosemount 2410 and other devices in a Rosemount Tank Gauging system with new firmware.

Prerequisites

Ensure that the latest versions of *.ini-files are installed on the TankMaster PC. New *.ini files can easily be installed by running the TankMaster setup program located in the DeviceIniFiles folder on the TankMaster installation CD.

Procedure

1. Ensure that the Rosemount 2410 communicates with TankMaster without any interruptions or disturbances.
2. In the **Rosemount TankMaster WinSetup** workspace window (Logical View), open the **Devices** folder and select the device to be upgraded (or select the **Devices** folder to allow multiple devices programming).

3. Right-click and select the **Program** option (**Program All** option for multiple devices programming). The device will automatically appear in the **Program These Devices** pane.

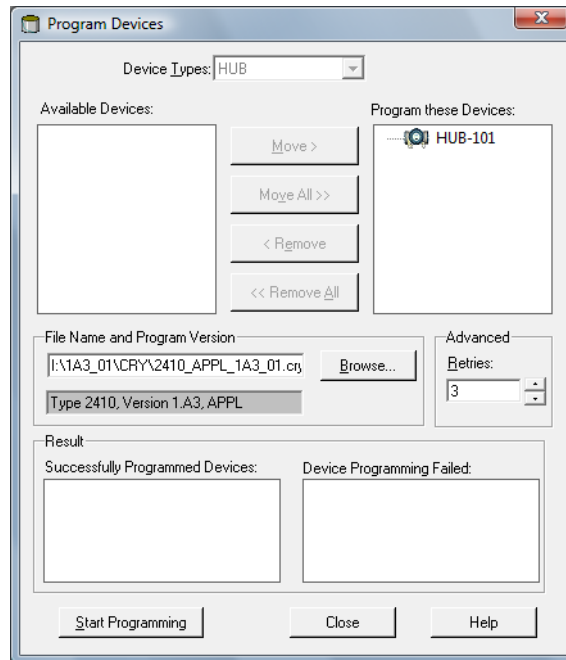

4. In case the **Devices** folder in the WinSetup workspace was selected for multiple programming, choose the desired device to be programmed from the **Available Devices** pane and click the **Move** button.

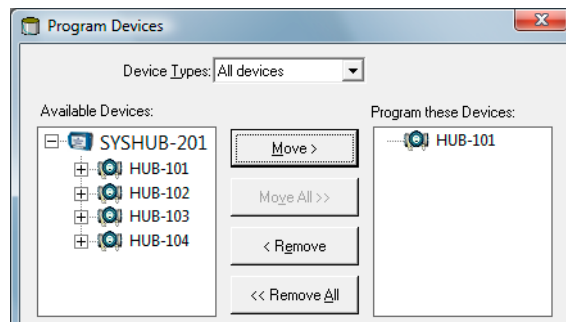

5. Repeat for each device to be programmed. Use the **Remove** button if you wish to change the list of devices to be programmed.
6. Click the **Browse** button to locate the flash program file. File extension *.cry is used for these files.

Example

For a Rosemount 2410, a flash file name may typically look like: 2410_APPL_xxx_yy.cry, where “x” and “y” indicate software version.

- Click the **Start Programming** button.

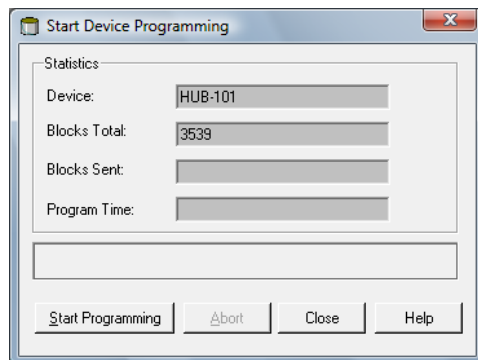

Now the **Start Device Programming** window appears.

- Click the **Start Programming** button to activate device programming.

Programming may take up to two hours for a Rosemount 2410 connected to a TankMaster PC via a 2460 System Hub. The programming procedure will continue with one device after the other until all Tank Hubs selected in the **Program Devices** window are upgraded. The Rosemount 2410 operates as normal during the reprogramming procedure.

By connecting a Rosemount 2410 directly to a host computer, and using the RS485 Modbus[®] protocol at a maximum baud rate of 38400, programming time may be reduced to 5 to 10 minutes (see [Change the communication parameters for the primary bus](#) for information on how to configure the Primary Bus).

Once programming is finished, the tank hub will automatically perform a restart indicated by "WAIT" on the integral display for a couple of minutes.

Postrequisites

Note

In case the current firmware version is significantly older than the new one, it is recommended that you load the default configuration database once the device is reprogrammed. Contact Emerson Automation Solutions/Rosemount Tank Gauging service department if you need further advice.

6.2.8 Write protection using TankMaster™

A Rosemount 2410 can be software write protected to avoid unintentional configuration changes. Software write protection locks the holding register database.

Procedure

1. Start the Rosemount TankMaster WinSetup program.
2. In the **TankMaster WinSetup** workspace, select the **Logical View** tab.
3. Right-click the device icon.

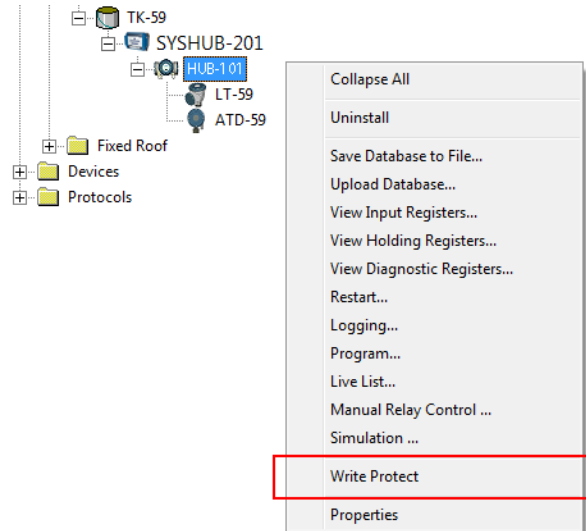

4. Select **Write Protect**.



5. In the **New State** drop-down list, select **Protected**, and then click the **Apply** button to save the new write protect state.
Now the holding register database is locked. As long as the device is write protected no configuration changes can be made.
6. Click the **OK** button to close the **Write Protect** window.

6.2.9 Write protection switch

A switch on the front of the Rosemount 2410 Tank Hub can be used to prevent unauthorized changes of the holding register database.

Figure 6-2: The Rosemount 2410 Tank Hub Write Protection Switch on the Built-in Integral display

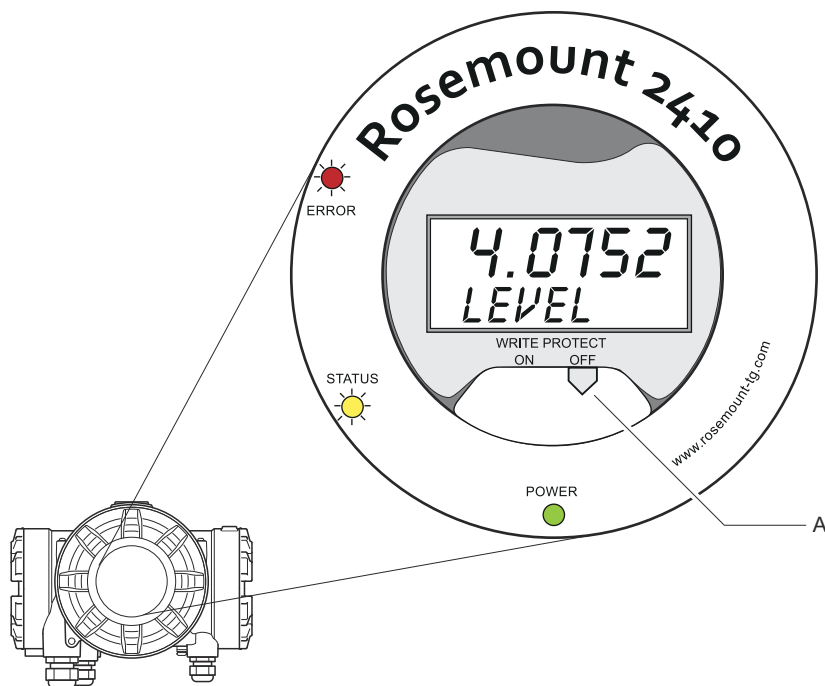

A. Write protection switch

6.2.10 Simulation mode

The Simulation Mode function lets you verify communication between a Rosemount 2410 Tank Hub and a host system without connecting actual field devices.

The **Rosemount 2410 Tank Hub Simulation** window allows you to choose which parameters to be calculated by the Rosemount 2410. Calculations are based on input from simulated tank measurement data such as product level, average temperature, liquid pressure, and other variables.

The Simulation HREGS holding registers (starting with register number 3800) lets you specify the desired simulation data.

For information on how to view and edit holding registers, see [Viewing input and holding registers using TankMaster™](#) or the Rosemount Tank Gauging [System Configuration Manual](#).

Procedure

1. In the **TankMaster WinSetup** workspace select the Rosemount 2410 icon.

- Click the right mouse button and choose the **Simulation** option to open the **Rosemount 2410 Tank Hub Simulation** window:

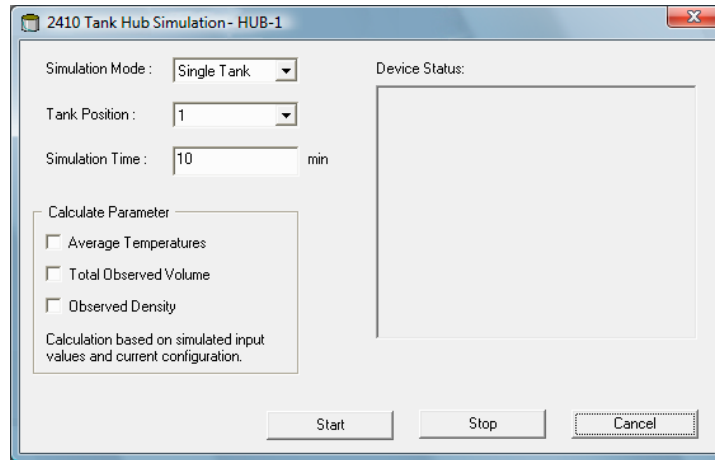

- Choose simulation mode **Single Tank** and the desired tank in the Tank Position field, or choose the **All** option to simulate all tanks connected to the Rosemount 2410. Tank Position refers to the position in the Rosemount 2410 tank database.
- In the **Simulation Time** field, enter for how long the simulation will continue. Simulation can be stopped at any time by pressing the **Stop** button.
- Calculate Parameter.

In the standard configuration the check-boxes are unchecked, which means that each simulation parameter is given a specific standard simulation value as specified in the simulation holding register area:

Table 6-2: Simulation Paramters

Simulation Parameter	Simulation Holding Register
Average Temperature	HR3868
Total Observed Volume	HR3994
Observed Density	HR3976

- Click the **Start** button to start simulating the tank parameters.

Note

Simulation continues for the specified period of time. It can also be stopped manually at any time by pressing the Stop button in the **Simulation** window.

In the **WinSetup** workspace the Rosemount 2410 icon changes to the following appearance to indicate that Simulation Mode is active:

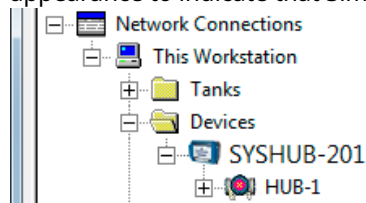

Advanced simulation

If a **Calculate Parameter** check-box is selected, the simulation parameter is calculated based on input data from the holding registers Simulation HREGS 3800 to 4056. You can simulate one or more parameters simultaneously.

Figure 6-3: Calculation Parameter

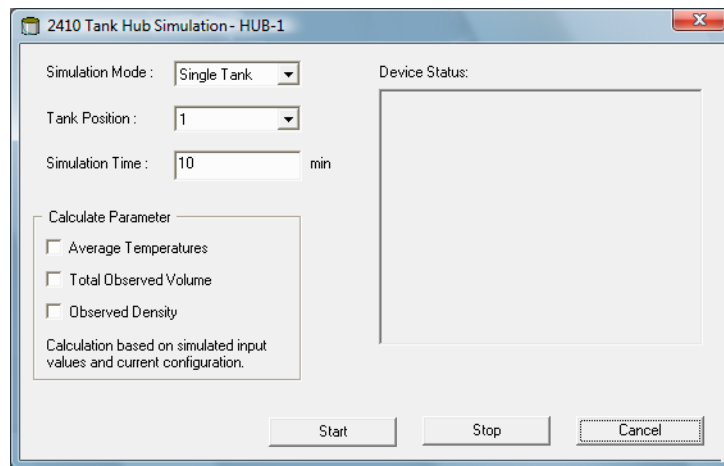

Procedure

1. For Average Temperature, the temperature element positions must be configured:
 - a) Right-click the auxiliary tank device (ATD) icon in the WinSetup workspace.
 - b) Choose the **Properties** option.
 - c) Select the **Average Temperature Calculation** tab. See the Rosemount Tank Gauging [System Configuration Manual](#) for more information.
The resulting product average temperature is available in input register IR2100 (tank 1). It is also available in input register area starting with IR30000 (IR30044 for tank 1).
2. The Volume Calculation function must be activated in order to enable advanced Volume simulation. See [Volume configuration](#) for more information.
The volume calculation result is presented in input register IR4702, IR3400 (tank 1) and in input register area starting with IR30000 (IR30148 for tank 1).
3. To simulate Observed Density the Hybrid Density function must be activated. See [Hybrid density configuration](#) for more information.
The resulting Observed Density is available in input register IR3500 (tank 1). It is also available in input register area starting with IR30000 (IR30116 for tank 1).

6.2.11 Testing the relays using TankMaster™

The Manual Control of Relay function lets you manually open or close the Rosemount 2410 Tank Hub built-in relays in order to verify the relay function. After the specified Safety Reset Time the relay automatically returns to normal mode. To change relay state by using the TankMaster WinSetup program do the following:

Procedure

1. In the **TankMaster WinSetup** workspace, select the Rosemount 2410 icon.
2. Right-click and select **Manual Control Relay**.
3. Select the virtual relay functions to be tested; Virtual Relay 1, Virtual Relay 2, etc. Up to ten virtual relay functions can be configured for a Rosemount 2410 Tank Hub.

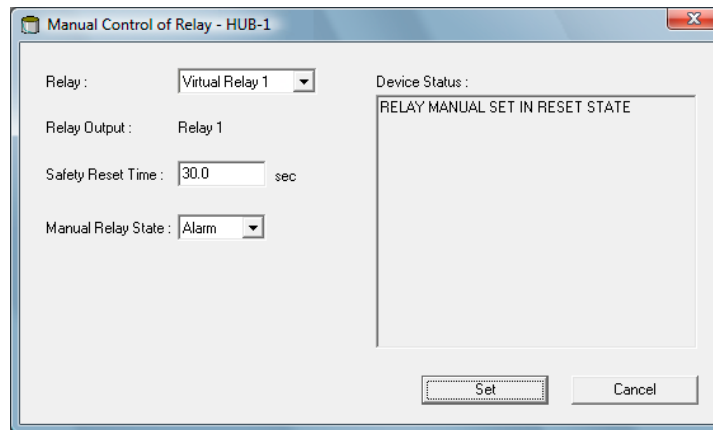

4. Specify a Safety Reset Time.
This value specifies the time period for the relay to stay in the test state. When the specified period of time has elapsed, the relay automatically returns to the original state. The relay will reset even if communication with the TankMaster PC would fail.
5. Choose the desired Manual Relay State. Available options are:
 - Alarm
 - Normal
 - Toggle
6. Click the **Set** button.
Now the selected relay changes state for the specified number of seconds and then returns to the previous state.

Related information

[Configure a virtual relay output](#)

6.2.12 Relay output configuration

To change the Normally Open/Normally Closed settings of the K1 and K2 relays, do the following:

Procedure

1. ⚠ Disconnect the power supply.
2. ⚠ Disconnect the relays.
3. Remove the front cover.

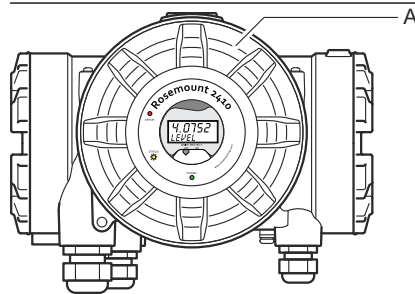

A. Front cover

4. Remove the plastic display cover.
5. Switch the jumpers to the desired settings: Normally Open (NO) or Normally Closed (NC).

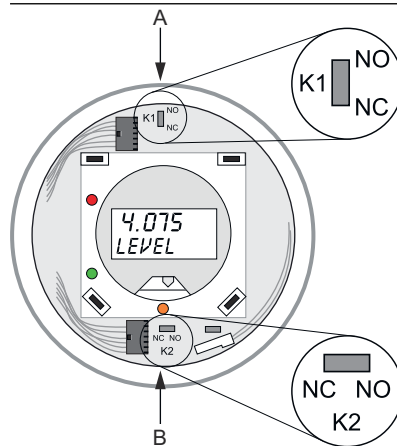

A. Relay K1: NO / NC
B. Relay K2: NC / NO

6. Replace the plastic display cover and the front cover.

Note

Ensure that o-rings and seats are in good condition prior to mounting the cover in order to maintain the specified level of ingress protection.

6.2.13 Loading the default database using TankMaster™

The various configuration parameters of the Rosemount 2410 Tank Hub is stored in a Holding Register database. The Holding Register factory setting is stored in the default database. TankMaster WinSetup offers the option to load the default database. This may be useful if, for example, you would like to try out new database settings and then be able to reload the original factory settings.

Prerequisites

In case error messages appear or other problems occur concerning the database, troubleshooting the cause of these problems is recommended before loading the default database.

It is recommended that the current database is backed up before the Default Database is loaded. See [Backing up a device configuration using TankMaster™](#) for information on how to save the current database.

Note

When the default database is loaded to the Rosemount 2410 Tank Hub, measurement units are reset to Metric units.

Note

The device address remains unaltered when the default database is loaded.

Procedure

1. In the **TankMaster WinSetup** workspace window, select the desired device icon.
2. Right-click and select **View Holding Register**.
3. Choose the **All** option and type 65510 in the **Start Register** input field.

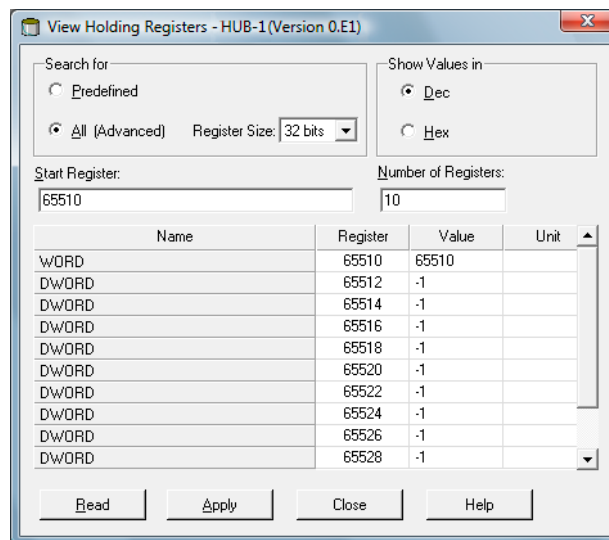

4. Type the desired number of registers to be displayed in the **Number of Registers** field and click the **Read** button.
5. In the **Value** input, type 65510.
6. Click the **Apply** button to load the default database.
7. Finish by clicking the **Close** button.
8. Verify that measurement units are compatible with the current host system configuration.

6.2.14 Logging measurement data using TankMaster™

The Rosemount 2410 supports logging of diagnostic registers. This function is useful for verifying that the gauge works properly. The logging function can be accessed by using the Rosemount TankMaster WinSetup program.

Procedure

1. Start the Rosemount TankMaster WinSetup program.
2. In the **TankMaster WinSetup** workspace window, select the device icon.
3. Right-click and select **Logging**.

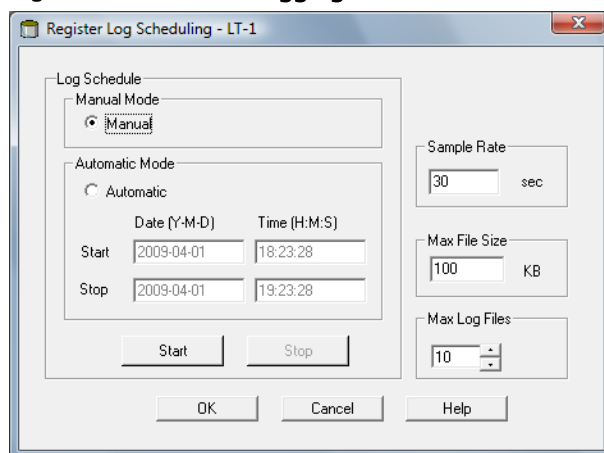

4. Select **Manual** or **Automatic** mode.

Option	Description
Manual	Manual mode lets you start logging at any time. Logging will proceed until it is stopped by clicking the Stop button.
Automatic	In Automatic mode you have to specify a Start and Stop time. Logging will proceed until the stop date and time is reached.

The resulting log file will not exceed the size specified by the Max File Size parameter. When the number of log files has reached the Max Log Files value, TankMaster starts replacing the contents of existing log files.

Log files

Log files are stored in plain text file format and can be viewed in any word processing program. They are stored in the following folder: C:\Rosemount\TankMaster\Log, where C is the disk drive where the Rosemount TankMaster software is installed.

A log file contains the same input registers as the **View Diagnostic Registers** window, see [View and configure diagnostic registers using TankMaster™](#). You can change which input registers to be included in the log file by configuring the **View Diagnostic Registers** window, see the Rosemount Tank Gauging [System Configuration Manual](#) for more information.

Figure 6-4: Log File

SEGOT01-01729_HUB-1.log - Notepad

File Edit Format View Help

 Device Name: HUB-1
 Device: 2410
 Started logging: 2009-02-05 16:54:48

Date	Time	IR1002	IR1004	IR1000	IR4002	IR4012	IR5112	IR1420	IR0	IR4	IR54	IR4006	IR2
2009-02-05	16:54:58	0	0	0	65536	2392.43	8	1	96521	9652	9652	9,85209	
2009-02-05	16:55:08	0	0	0	65536	2392.7	8	1	96521	9652	9652	9,8521	
2009-02-05	16:55:18	0	0	0	65536	2395.7	8	1	96521	9652	9652	9,85215	
2009-02-05	16:55:28	0	0	0	65536	2392.06	8	1	96522	9652	9652	9,85213	
2009-02-05	16:56:14	0	0	0	65536	2393.5	8	1	96522	9652	9652	9,8522	
2009-02-05	16:56:24	0	0	0	65536	2388.86	8	1	96522	9652	9652	9,85217	
2009-02-05	17:03:29	0	0	0	65536	2390.95	8	1	96521	9652	9652	9,85204	
2009-02-05	17:07:08	0	0	0	65536	2392.85	8	1	96521	9652	9652	9,85205	
2009-02-05	17:07:18	0	0	0	65536	2392.93	8	1	96521	9652	9652	9,85207	
2009-02-05	17:07:28	0	0	0	65536	2392.92	8	1	96521	9652	9652	9,85207	

6.3 Troubleshooting

Table 6-3: Troubleshooting chart

Symptom	Possible cause	Action
No contact with the Rosemount 2410 Tank Hub	Wiring	<ul style="list-style-type: none"> • Check that wires are properly connected to the terminals. • Check for dirty or defective terminals. • Check wire insulation for possible short circuits to ground. • Check that the Rosemount 2410 Tank Hub is connected to the right communication port on the control room PC (if no 2460 System Hub or FCU 2160 is used).
	RS485 wiring	Check for proper polarity at the terminals.
	Field Bus Modem (FBM)	<ul style="list-style-type: none"> • Check the LEDs for proper communication. • Check that the FBM is connected to the right port on the control room PC. • Check that the FBM is connected to the right port on the 2160 Field Communication Unit (FCU).
	Connection to Rosemount 2460 System Hub	Check that the Rosemount 2410's Primary/Secondary bus is connected to the right port on the Rosemount 2460 System Hub.
	Configuration of Rosemount 2460 System Hub	<ul style="list-style-type: none"> • Check the communication address specified for the Rosemount 2410 in the Rosemount 2460's tank database. • Check configuration of communication parameters for the Rosemount 2460 ports. • Check that the correct communication channel is selected. • See the Rosemount 2460 Reference Manual for more information on how to configure the 2460 System Hub.
	Connection to FCU 2160	<ul style="list-style-type: none"> • Check that the Rosemount 2410 Primary/Secondary bus is connected to the right field bus port on the FCU 2160. • Check communication port LED:s inside the 2160 Field Communication Unit (FCU).
Configuration of FCU 2160	<ul style="list-style-type: none"> • Check the communication address specified for the Rosemount 2410 in the FCU Slave Database. • Check configuration of communication parameters for the FCU Fieldbus ports. • Check that the correct communication channel is selected. <p>See the Rosemount Tank Gauging System Configuration Manual for more information on how to configure the FCU 2160.</p>	

Table 6-3: Troubleshooting chart (*continued*)

Symptom	Possible cause	Action
	Configuration of communication protocol	In TankMaster WinSetup/Protocol Channel Properties: <ul style="list-style-type: none"> • check that the protocol channel is enabled • check the protocol channel configuration (port, parameters, modem).
No contact with the Rosemount 2410 Tank Hub	Hardware failure	<ul style="list-style-type: none"> • Check the Rosemount 2410 Tank Hub; check the Error LED or the integral display for information. • Check the 2460 System Hub (or 2160 Field Communication Unit). • Check the Field Bus Modem. • Check the communication port on the control room PC. • Check that all devices connected to the Primary/Secondary bus are powered. • Contact Emerson Automation Solutions/ Rosemount Tank Gauging service department.
	Software failure	<ul style="list-style-type: none"> • Restart the Rosemount 2410 by disconnecting and connecting the power supply (note the communication parameters that appear on the display during startup).

Table 6-3: Troubleshooting chart (continued)

Symptom	Possible cause	Action
No communication with one or more devices on the Tankbus	Wiring	<ul style="list-style-type: none"> • Check that the devices appear in the Device Live List (see View the device live list in TankMaster™). • Check diagnostics information, see View and configure diagnostic registers using TankMaster™ for warning or error messages. • Check that wires are properly connected to the terminals. • Check for dirty or defective terminals. • Check wire insulation for possible short circuits to ground. • Check diagnostics information (see View and configure diagnostic registers using TankMaster™) for information that indicate bad communication on the Tankbus: - Input registers 1300 to 1328 provide general information on Tankbus communication - Input registers 1330 to 1648 provide information on specific devices on the Tankbus. • Check diagnostics information (see View and configure diagnostic registers using TankMaster™) for possible hardware faults that indicate short circuits or ground faults: - check Input Register 1326 for short circuits - check Input Register 1328 for ground faults. • Check that there are no multiple shield grounding points • Check that the cable shield is grounded at the power supply end (Rosemount 2410 Tank Hub) only. • Check that the cable shield is continuous throughout the Tankbus network. • Check that the shield inside the instrument housing does not come into contact with the housing. • Check that there is no water in conduits. • Check for proper polarity at the terminals (Rosemount 5300 and 5408). • Use shielded twisted pair wiring. • Connect wiring with drip loops. • Check the loop impedance.
	Incorrect Tankbus termination	<ul style="list-style-type: none"> • Check that there are two terminators on the Tankbus (see section Termination). • Check that terminations are placed at both ends of the Tankbus. • Check that the built-in termination in the Rosemount 2410 Tank Hub is enabled.

Table 6-3: Troubleshooting chart (continued)

Symptom	Possible cause	Action
	Too many devices on the Tankbus	<ul style="list-style-type: none"> Check that the total current consumption of the devices on the Tankbus is less than 250 mA, see Power budget. Remove one or more devices from the Tankbus. The Rosemount 2410 Tank Hub supports a single tank. The multiple tank version of the Rosemount 2410 supports up to 10 tanks.
No communication with one or more devices on the Tankbus	Cables are too long	Check that the input voltage on the device terminals is 9 V or more (see section Fieldbus segment design).
	Software or hardware failure	<ul style="list-style-type: none"> Check diagnostics information, see View and configure diagnostic registers using TankMaster™. Check Device Status input register, see Device status. Contact Emerson Automation Solutions/ Rosemount Tank Gauging service department.
TankMaster does not present measurement data from one or more devices connected to the Tankbus. The devices communicate on the Tankbus and appear in the Device Live List.	Incorrect configuration of the 2160 FCU slave database	Check the Modbus communication addresses in the 2160 FCU slave database. In TankMaster WinSetup open the FCU Properties/Slave Database window. See the Rosemount Tank Gauging System Configuration Manual for more information on how to configure the 2160 FCU slave database.
	Incorrect configuration of the Rosemount 2460 tank database	Check the Modbus communication addresses in the 2460 tank database. In TankMaster WinSetup open the 2460 Properties/Slave Database window. See the Rosemount 2460 Reference Manual for more information on how to configure the 2460 tank database.

Table 6-3: Troubleshooting chart (continued)

Symptom	Possible cause	Action
	Incorrect configuration of the Rosemount 2410 tank database	<p>Check the Rosemount 2410 tank database; ensure that the device is available and mapped to the right tank.</p> <p>Rosemount 2460 System Hub tank database:</p> <ul style="list-style-type: none"> • Check the Rosemount 2410 tank database configuration; verify that the ATD Modbus address is equal to the Temp Device address. • Check the Rosemount 2410 tank database configuration; verify that the Level Modbus address is equal to the Level Device address. • See the Rosemount 2460 Reference Manual for more information on how to configure the tank databases of the 2460 System Hub and the Rosemount 2410 Tank Hub. <p>2160 FCU Slave Database:</p> <ul style="list-style-type: none"> • Check the Rosemount 2410 tank database configuration; verify that the ATD Modbus address is equal to the 2410 Temp Modbus address. • Check the Rosemount 2410 tank database configuration; verify that the Level Modbus address is equal to the 2410 Level Modbus address. • See the Rosemount Tank Gauging System Configuration Manual for more information on how to configure the FCU 2160 Slave Database and the Rosemount 2410 tank database.
	Software or hardware failure	<ul style="list-style-type: none"> • Check diagnostics information, see View and configure diagnostic registers using TankMaster™. • Check Device Status input register, see Device status. • Contact Emerson Automation Solutions/ Rosemount Tank Gauging service department.
	Too many devices connected to the Tankbus	<ul style="list-style-type: none"> • Check the model code to find out what type of Rosemount 2410 Tank Hub that is used: Single tank or Multiple tank version. • Change to a Rosemount 2410 Tank Hub for multiple tanks.
Incorrect temperature reading from temperature transmitter	Configuration error	<ul style="list-style-type: none"> • Check configuration of the temperature transmitter; in TankMaster Winsetup open Properties for the ATD device associated with the tank. • See the Rosemount Tank Gauging System Configuration Manual for more information on how to configure ATD devices such as a Rosemount 2240S Multi-Input Temperature Transmitter.

Table 6-3: Troubleshooting chart (continued)

Symptom	Possible cause	Action
	Measurement units are not compatible with host system	If default database is loaded to the Rosemount 2410 Tank Hub, do one of the following: <ul style="list-style-type: none"> in TankMaster WinSetup verify system units and re-install the tank associated with the Rosemount 2410 Tank Hub update Holding Registers with correct measurement units
	Hardware failure	<ul style="list-style-type: none"> Check diagnostics information, see View and configure diagnostic registers using TankMaster™. Check temperature elements. Contact Emerson Automation Solutions/Rosemount Tank Gauging service department.
Incorrect level reading from radar level gauge	Configuration error	<ul style="list-style-type: none"> Check configuration of the level gauge; in TankMaster Winsetup open Properties for the level gauge associated with the tank. See the Rosemount 5900S Reference Manual and the Rosemount Tank Gauging System Configuration Manual for more information on how to configure a Rosemount 5900S Radar Level Gauge.
	Measurement units are not compatible with host system	If default database is loaded to the Rosemount 2410 Tank Hub, do one of the following: <ul style="list-style-type: none"> in TankMaster WinSetup verify system units and re-install the tank associated with the tank hub update Holding Registers with correct measurement units
	Hardware failure	<ul style="list-style-type: none"> Check diagnostics information, see View and configure diagnostic registers using TankMaster™. Contact Emerson Automation Solutions/Rosemount Tank Gauging service department.
No output on the Rosemount 2410 integral display	Hardware failure	<ul style="list-style-type: none"> Check the model code to verify that the Rosemount 2410 was ordered with the LCD display option. Check display connection. Check diagnostics information, see View and configure diagnostic registers using TankMaster™. Contact Emerson Automation Solutions/Rosemount Tank Gauging service department.
The Error LED (red) is blinking	Various reasons such as hardware or software failure, communication, or configuration error	<ul style="list-style-type: none"> See Error codes and Error messages. Check Device Status input register (see Device status).
The Status LED (yellow) is blinking	Normal operation. The yellow Status LED blinks at a constant rate of one flash every other second.	See LED for more information.
Configuration can not be saved	Write protection switch is set to the ON position	Check write protection switch on the display, see Write protection switch .

Table 6-3: Troubleshooting chart (continued)

Symptom	Possible cause	Action
	The Rosemount 2410 is write protected in TankMaster WinSetup	Check write protection in TankMaster WinSetup, see Write protection using TankMaster™ .
	Application software installed which is incompatible with current holding register setup	Reset holding registers to the default database setting, see Loading the default database using TankMaster™ and restart the Rosemount 2410 Tank Hub.
	Corrupt holding registers	Reset holding registers to the default database setting, see Loading the default database using TankMaster™ and restart the Rosemount 2410 Tank Hub.
Rosemount 2410 icon in TankMaster WinSetup is red	Simulation mode active	Stop simulation mode; open WinSetup Set Simulation Mode window and click the Stop button.
All measurement values are indicated with "SensFail" in the WinSetup Tank View window, and with "Error" in the WinOpi Tank View window.	Map conflict. One or more tank measurement variables are mapped to the wrong source parameter. For example: Vapor Temperature is mapped to Manual Value.	<ul style="list-style-type: none"> Check diagnostics information (see View and configure diagnostic registers using TankMaster™) for possible Device Warning messages: - in case there is a "Data Manager" warning, check Input Register 6244 - if register 6244 indicates a "TMV Mapping" warning check Input Registers 6260 to 6270 for tank measurement variable mapping conflicts In TankMaster Winsetup, right-click the ATD device icon associated with the current tank, and click the Properties option. In the 22XX ATD window select the Advanced Parameter Source Configuration tab. Check that tank measurement variables are mapped to the right source parameters.

6.3.1 Device status

The current device status is shown in Input Register 1000. You can view the device status register by opening the **Diagnostic** window or the **View Input Registers** window.

Double-clicking the Value field of the Device Status register opens an expanded bitfield window with information on the current device status as shown in [Figure 6-5](#).

Figure 6-5: Input Register Device Status

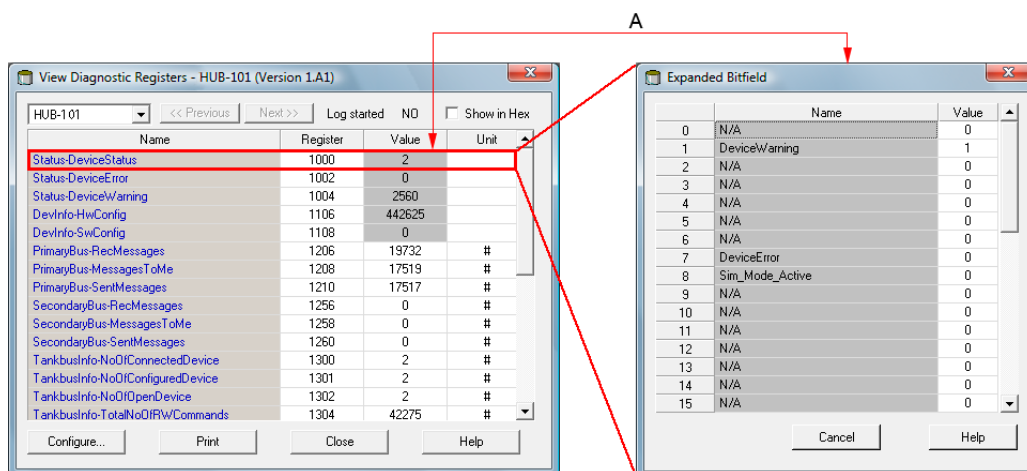

A. Double-click the **Value** field to open the **Expanded Bitfield** window

Table 6-4: Device Status Messages

Message	Bit no.	Description	Action
Device Warning	1	A device warning is active.	See Warning messages for details.
Device Error	7	A device error is active.	See Error messages for details.
Simulation Mode Active	8	Simulation mode active.	Stop Simulation mode.
Write Protected	18	The device is write protected with a switch or in the TankMaster WinSetup program.	Check the write protection switch, see Write protection switch . Check write protection state in TankMaster WinSetup, see Write protection using TankMaster™ .

Related information

[View and configure diagnostic registers using TankMaster](#)

[Viewing input and holding registers using TankMaster](#)

6.3.2 Warning messages

Warning messages are displayed in the Rosemount TankMaster program. Input Register 1004 provides an overview of active device warnings (see [View and configure diagnostic registers using TankMaster™](#) or [Viewing input and holding registers using TankMaster™](#) for information on how to view diagnostics and various Input registers in TankMaster WinSetup).

For each warning message that may appear in Input register 1004, detailed information can be found in Input registers 6200 to 6248 as shown in [Table 6-5](#).

Table 6-5: Warning Message Descriptions

Message	Description	Action
RAM warning	Input register no. 6200.	Contact Emerson Automation Solutions/Rosemount Tank Gauging service department.
FEPROM warning	Input register no. 6204.	
Hreg warning	Input register no. 6208.	
SW warning	Input register no. 6212.	
Other memory warning	Input register no. 6216. Bit 1: Stack	
System warning	Input register no. 6220.	
Display warning	Input register no. 6224. Bit 0: Communication Bit 1: Configuration	
Aux warning	Input register no. 6228. Bit 0: Internal temperature Bit 1: Power	
FF stack warning	Input register no. 6232.	
Tankbus communication warning	Input register no. 6236. Bit 0: Device restarted Bit 1: Device open failed Bit 2: Device address changed Bit 3: Live List no free position Bit 4: Port changed Bit 5: Exceeded FF number of retries Bit 6: Power failure Bit 7: Ground failure	
Host communication warning	Input register no. 6240. Bit 0: Multiple configuration Bit 1: Primary bus configuration Bit 2: Secondary bus configuration	
Data Manager warning	Input register no. 6244. Bit 0: Frozen data Bit 1: TMV mapping	
Configuration warning	Input register no. 6248. Bit 0: Invalid strapping table Bit 1: Tank configuration Bit 11: Model Code invalid string Bit 12: Model Code invalid code	

Table 6-5: Warning Message Descriptions (continued)

Message	Description	Action
Map conflict tank no.	Input register no. 6260	<p>Check that tank measurement variables are mapped to the right source parameters:</p> <ol style="list-style-type: none"> 1. In TankMaster Winsetup, right-click the ATD device icon associated with the current tank. 2. Click the Properties option. 3. In the 22XX ATD window select the Advanced Parameter Source Configuration tab. <p>Contact Emerson Automation Solutions/Rosemount Tank Gauging service department.</p>
Map conflict TMV type (TMV=Tank Measurement Variable)	Input register no. 6262 0: TMV Level 1: TMV Ullage 2: TMV Level Rate 3: TMV Signal Strength 4: TMV Free Water Level 5: TMV Vapor Pressure 6: TMV Liquid Pressure 7: TMV Air Pressure 8: TMV Ambient Temperature 9: TMV Vapor Avg Temperature 10: TMV Liquid Avg Temperature 11: TMV Tank Avg Temperature 12-27: TMV Temp1 - TMV Temp 16 50: TMV Observed Density 51: TMV Reference Density 52: TMV Flow Rate 53: TMV Tank Volume 54: TMV Tank Height 55: TMV Middle Pressure 56: TMV Delta Level 60-64: TMV USER DEF 1 - 5	
Map conflict device 1	Input register no. 6264	
Map conflict device 1 TV no. (TV=Tank Variable)	Input register no. 6266 TV number 0 - 1019 (Level, Ullage, Level Rate, Signal Strength etc.)	
Map conflict device 2	Input register no. 6268	
Map conflict device 2 TV no. (TV=Tank Variable)	Input register no. 6270 TV number 0 - 1019 (Level, Ullage, Level Rate, Signal Strength etc.)	
Internal map conflict	Input register no. 6272 Bit 1: TMV Vapor average temperature Bit 2: TMV Liquid average temperature Bit 3: TMV Tank average temperature Bit 4: TMV Observed Density Bit 5: TMV Reference Density Bit 6: TMV Tank Volume Bit 7: Mult TV Map Bit 8: TMV Internal Map Bit 9: TMV Arithmetic Value	

6.3.3 Error messages

Error messages may be displayed on the Rosemount 2410 integral display and in the Rosemount Tankmaster program. You also have the option to view Input Register 1002 for an overview of active device errors (see [View and configure diagnostic registers using TankMaster™](#) or [Viewing input and holding registers using TankMaster™](#) for information on how to view diagnostics and various Input registers with TankMaster WinSetup).

For each error message that may appear in Input register 1002, detailed information can be found in Input registers 6100 to 6124 as shown in [Table 6-6](#).

Table 6-6: Error Message Descriptions

Message	Description	Action
RAM error	Input register no. 6100. A gauge data memory (RAM) error has been detected during the startup tests. Note: this automatically resets the gauge.	Contact Emerson Automation Solutions/Rosemount Tank Gauging service department.
FEPROM error	Input register no. 6102: Bit 0: checksum Bit 1: Application version Bit 2: Application checksum	Probably a checksum error in the application software. Try to reprogram the Rosemount 2410.
HREG error	Input register no. 6104: Bit 0: Checksum Bit 1: Limit Bit 2: Version Bit 3: Read Bit 4: Write	Probably a checksum error caused by power failure between a configuration change and CRC update. Reset to factory configuration (see Loading the default database using TankMaster™) and reconfigure the Rosemount 2410. Use the Reset command before checking the error status.
SW error	Input register no. 6106: Bit 0: Undefined SW Error Bit 1: Task Not Running Bit 2: Out of stack space Bit 3: Unused RAM access Bit 4: Divide by zero Bit 5: Reset Counter Overflow Bit 15: Simulated SW Error	The Rosemount 2410 software is having trouble running stable. <ol style="list-style-type: none"> 1. Switch off the power to the tank hub for at least one minute. 2. Switch power on again. If the problem persists, contact Emerson Automation Solutions/Rosemount Tank Gauging service department.
Other Memory Error	Input register no. 6108: Bit 0: CheckSum Bit 1: Stack	Contact Emerson Automation Solutions/Rosemount Tank Gauging service department
Sys Error	Input register no. 6110. Bit 0: Task Supervisor	
Display Error	Input register no. 6112. Bit 0: Hardware Bit 1: Com Bit 2: Configuration	

Table 6-6: Error Message Descriptions (continued)

Message	Description	Action
Aux Error	Input register no. 6114. Bit 0: Internal temperature out of limits Bit 1: Internal temp measurement failed Bit 2: Internal temperature device failed Bit 3: Relay 1 Bit 4: Relay 2 Bit 5: Power	
FF Stack Error	Input register no. 6116.	
Tankbus Communication Error	Input register no. 6118. Bit 0: Unknown device connected to the Tankbus	
Host Communication Error	Input register no. 6120. Bit 1: Hardware Primary modem Bit 2: Hardware Secondary modem Bit 3: Illegal Primary modem Bit 4: Illegal Secondary modem	
Data Manager Error	Input register no. 6122. Bit 1: Tank configuration	
Configuration Error	Input register no. 6124.	

A Specifications and reference data

A.1 General specifications

A.1.1 Material selection

Emerson provides a variety of Rosemount products with various product options and configurations, including materials of construction that can be expected to perform well in a wide range of applications.

The product information presented is intended as a guide for the purchaser to make an appropriate selection for the application. It is the purchaser's sole responsibility to make a careful analysis of all process parameters (such as all chemical components, temperature, pressure, flow rate, abrasives, contaminants, etc.), when specifying product, materials, options, and components for the particular application. Emerson is not in a position to evaluate or guarantee the compatibility of the process fluid or other process parameters with the product, options, configuration, or materials of construction selected.

A.1.2 Single tank version

For a Rosemount 5900 system configuration when used in BPCS and safety instrumented systems:

- Supports one Rosemount 5900S 2-in-1 gauge or up to two Rosemount 5900 standard gauges
- Total Observed Volume (TOV) and API corrected Net Standard Volume (NSV) calculation with 100-point strapping table

A.1.3 Multiple tank version

For a Rosemount 5300/5408/5900 system configuration:

- The software supports 16 field devices and 10 tanks per tank hub
- Maximum five type Rosemount 5300 gauges per tank hub

The actual number of tanks/instruments a tank hub supports depends on the configuration, which types of units are connected and how many:

- Hybrid calculations (mass and density) for up to three tanks
- Total Observed Volume (TOV) and API corrected Net Standard Volume (NSV) calculation with 100-point strapping table for one tank

For more information, see [Table A-5](#).

A.1.4 Functional safety/SIS applications (SIL 2 single tank) version

The Rosemount 2410:SIS Tank Hub is included in a Rosemount 5900 system configuration when used in safety instrumented systems:

- Supports one Rosemount 5900 SIL 2 safety level device for overfill or dry-run protection
- SIL 2 certified outputs (Relays and Analog Output)

- Data is limited to Tank Position 1: Level, Ullage, Level Rate, Signal Strength, Tank Height, Vapor Temp (Temp 1), and Vapor Pressure
- Typically used in combination with Rosemount 2410 single tank hub for an independent SIL certified protection layer

A.1.5 Supported Rosemount field devices

Level

Rosemount 5900 Radar Level Gauge⁽¹⁵⁾, Rosemount 5408 Level Transmitter, Rosemount 5300 Level Transmitter, and Rosemount 5400 Level Transmitter

Temperature

Rosemount 2240S Multi-input Temperature Transmitter, Rosemount 3144P Temperature Transmitter, Rosemount 848T Temperature Transmitter, and Rosemount 644 Temperature Transmitter

Display

Rosemount 2230 Graphical Field Display and Rosemount 752 FOUNDATION™ Fieldbus Remote Indicator

Pressure

Rosemount 3051 Pressure Transmitter, Rosemount 2051 Pressure Transmitter, Rosemount 3151 Pressure Transmitter, and Rosemount 3051SMV MultiVariable Mass Flow Transmitter

Logic input and output

Rosemount 848L Logic Transmitter with FOUNDATION Fieldbus

Density

Micro Motion™ FDM Fork Density Meter

A.1.6 Supported field devices from other vendors

Temperature

Foxboro® RTT15-F Temperature Transmitter, PR electronics 6350 FOUNDATION™ Fieldbus Transmitter, PR electronics 5350 FOUNDATION Fieldbus Transmitter, Siemens SITRANS TH400, and WIKA T53 Fieldbus Temperature Transmitter

Pressure

Honeywell® SmartLine ST700 Pressure Transmitter, Honeywell SmartLine ST800 Pressure Transmitter, Yokogawa® EJA Series Differential Pressure Transmitter, and Yokogawa EJX430A Gauge Pressure Transmitter

A.1.7 Start-up time

Less than 30 s

(15) One Rosemount 5900S with a 2-in-1 solution or maximum two standard Rosemount 5900 gauges installed on separate tanks can be connected to one tank hub.

A.2 Communication/display/configuration specifications

A.2.1 Tankbus

The intrinsically safe side of the Rosemount 2410 connects to the Tankbus, which communicates with the field devices on the tank using FOUNDATION™ Fieldbus.

A.2.2 Fieldbus

Rosemount 2410 communicates with a Rosemount 2460 System Hub, Rosemount TankMaster, or a host via the supported communication protocols for the primary and secondary fieldbus.

Primary fieldbus: TRL2 Modbus, RS485 Modbus, Analog output/input 4-20 mA/HART, Enraf® Bi-phase Mark GPU, Whessoe WM 550/660 (digital current loop), GPE 31422/31423 (digital current loop), Sakura MDP/V1, or Tokyo Keiso.

Secondary fieldbus: TRL2 Modbus, Analog output/input 4-20 mA/HART, *WirelessHART*®, Enraf Bi-phase Mark GPU, L&J Tankway 1500 XL/MCG 2000, Varec® Mark/Space GT 1800/1900, Whessoe WM 550/660 (digital current loop), GPE 31422/31423 (digital current loop), Sakura MDP/V1 or Tokyo Keiso.

For combination guidance, see [Table A-1](#), [Table A-2](#), and [Table A-3](#).

A.2.3 Relay outputs

SIL 3 relay output: One certified SIL 3 relay is available for overfill prevention. This non-intrinsically safe solid state relay is closed/energized during normal operation.

Maximum voltage and current: 260 Vac/Vdc, 80 mA single pole

Relay outputs (SIL 2 or non-SIL): Maximum two relays, controlled by 10 independent virtual relay functions, which can be configured for different tanks and process variables. The two non-intrinsically safe solid state relays are user configurable for normally energized or de-energized operation.

Maximum voltage and current: 350 Vac/Vdc, 80 mA single pole

For combination guidance, see [Table A-1](#), [Table A-2](#), and [Table A-3](#).

A.2.4 Analog input/output

The tank hub supports analog output and input 4-20 mA/HART, active or passive, IS or non-IS. The analog output is available as certified SIL 2.

Analog input

Maximum number of input channels: 1

Input Current range: 0-23 mA

Configurable Min and Max alarm limits.

For IS parameters, see [Product Certifications](#).

External Supply Voltage:

- Passive Non-IS: 7.2 - 35 Vdc
- Passive IS: 8.7 - 30 Vdc

Maximum Output Voltage (open loop):

- Active Non-IS: 24 Vdc
- Active IS: 23 Vdc

HART master:

- Maximum 5 HART Slave Devices (Passive)
- Maximum 3 HART Slave Devices (Active)

Figure A-1: Loop Resistance: Passive Non-IS Analog Input

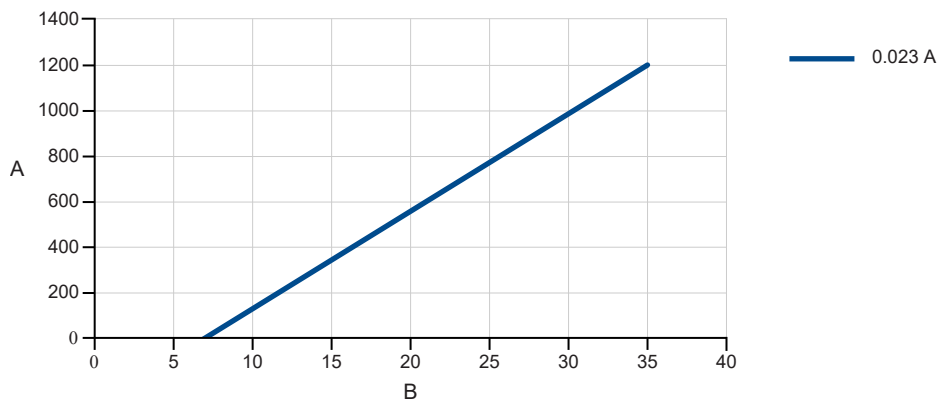

A. Loop resistance [Ω]

B. External power supply voltage [V]

Max Loop Resistance⁽¹⁶⁾ @ 23 mA = 43.4 * (External Power Supply Voltage - 7.2) [Ω]

(16) Any sense resistance must be subtracted from calculated max loop resistance to receive the maximum cable resistance.

Figure A-2: Loop Resistance: Passive IS Analog Input

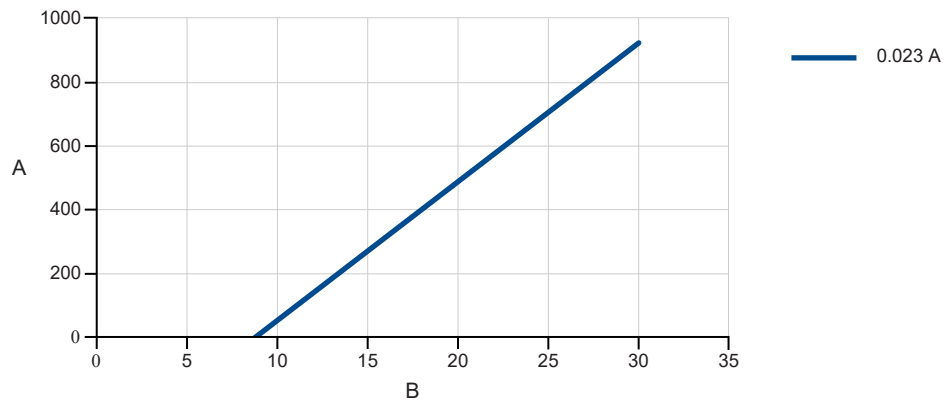

- A. Loop resistance [Ω]
- B. External power supply voltage [V]

$$\text{Max Loop Resistance}^{(16)} @ 23 \text{ mA} = 43.4 * (\text{External Power Supply Voltage} - 8.7) [\Omega]$$

Figure A-3: Loop Resistance: Active Non-IS Analog Input

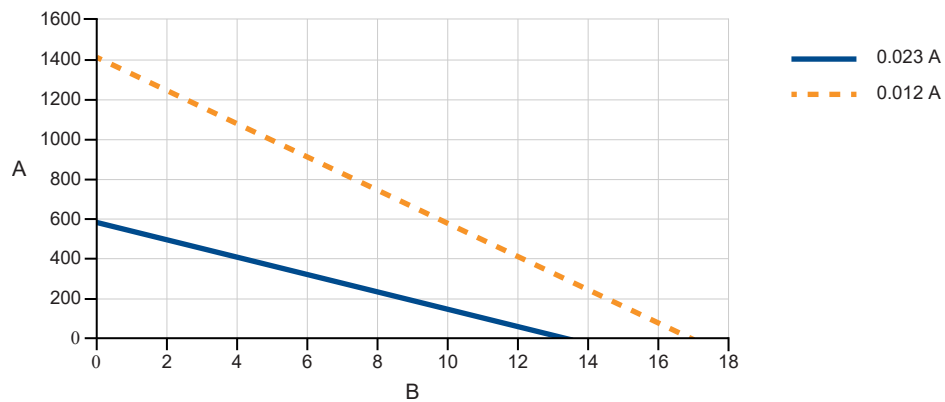

- A. Loop resistance [Ω]
- B. Lift-off voltage [V]

$$\text{Max Loop Resistance}^{(16)} = (20.9 - \text{Lift-off Voltage}) / \text{Max Loop Current} - 330 [\Omega]$$

Figure A-4: Loop Resistance: Active IS Analog Input

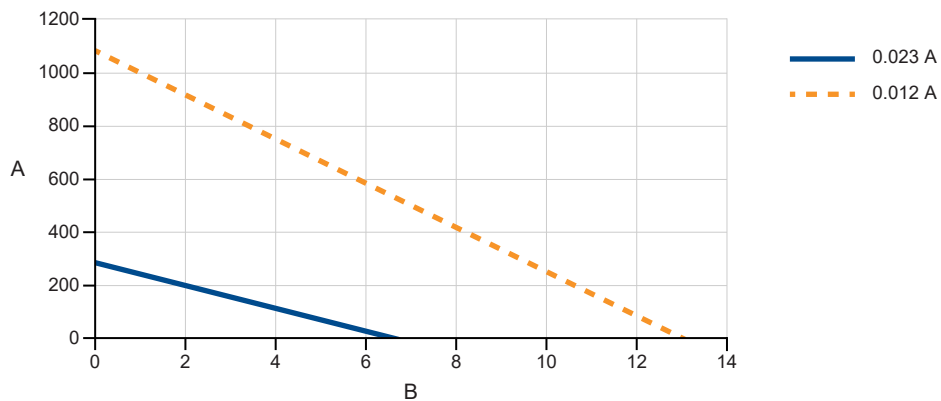

A. Loop resistance [Ω]

B. Lift-off voltage [V]

$$\text{Max Loop Resistance}^{(16)} = (20.1 - \text{Lift-off Voltage}) / \text{Max Loop Current} - 590 \text{ [}\Omega\text{]}$$

Analog output

Maximum number of output channels: 1

Output range: 3.5-23 mA

Software configurable High and Low Alarm Limits.

Separate software configurable alarms for process and hardware failures.

Low voltage and invalid loop current detection.

SIL 2 capable.

External Supply Voltage:

- Passive Non-IS: 8.0 - 35 Vdc
- Passive IS: 9.4 - 30 Vdc

Maximum Output Voltage (open loop):

- Active Non-IS: 24 Vdc
- Active IS: 23 Vdc

Figure A-5: Loop Resistance: Passive Non-IS Analog Output

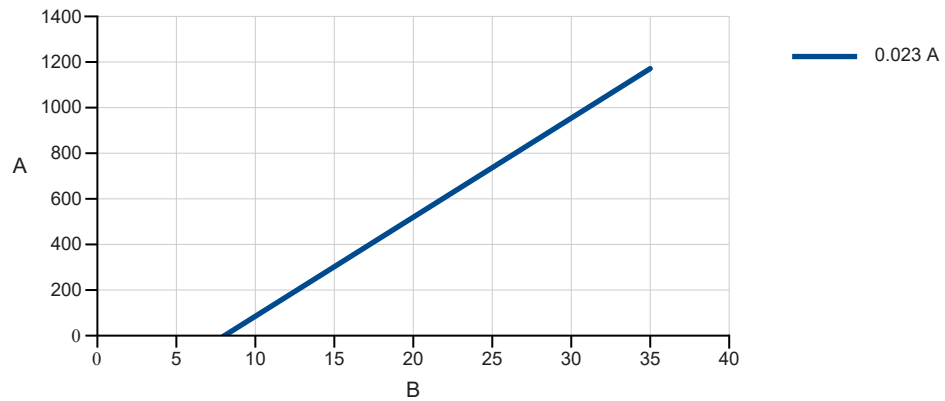

- A. Loop resistance [Ω]
- B. External power supply voltage [V]

Max Loop Resistance⁽¹⁶⁾ @ 23 mA = 43.4 * (External Power Supply Voltage - 8) [Ω]

Figure A-6: Loop Resistance: Passive IS Analog Output

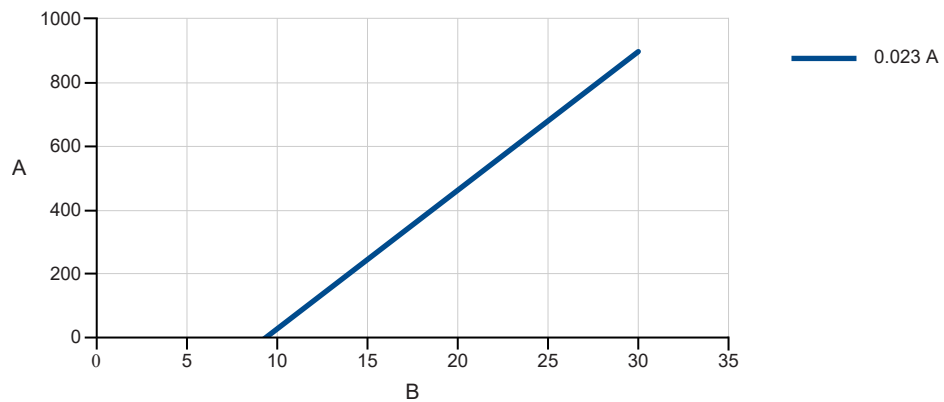

- A. Loop resistance [Ω]
- B. External power supply voltage [V]

Max Loop Resistance⁽¹⁶⁾ @ 23 mA = 43.4 * (External Power Supply Voltage - 9.4) [Ω]

Figure A-7: Loop Resistance: Active Non-IS Analog Output

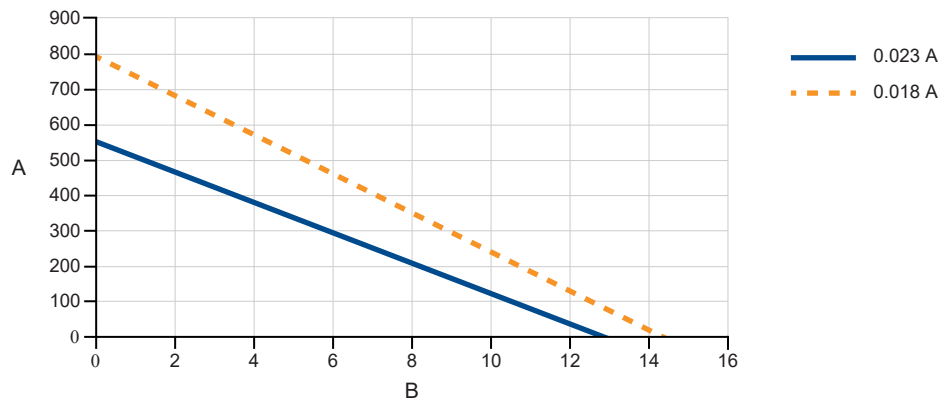

A. Loop resistance [Ω]

B. Lift-off voltage [V]

$$\text{Max Loop Resistance}^{(16)} = (20.3 - \text{Lift-off Voltage}) / \text{Max Loop Current} - 330 \text{ [}\Omega\text{]}$$

Figure A-8: Loop Resistance: Active IS Analog Output

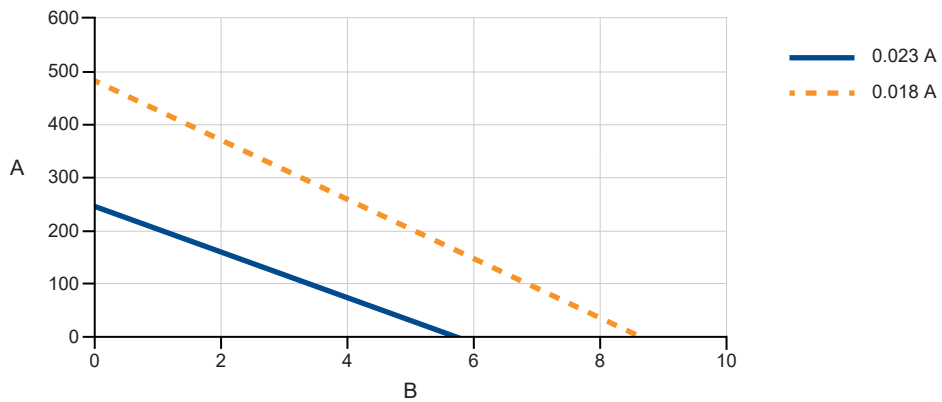

A. Loop resistance [Ω]

B. Lift-off voltage [V]

$$\text{Max Loop Resistance}^{(16)} = (19.5 - \text{Lift-off Voltage}) / \text{Max Loop Current} - 600 \text{ [}\Omega\text{]}$$

A.2.5 Fieldbus combinations

Table A-1: Fieldbus Combination Matrix (Non-SIL)

		Primary Fieldbus options					
		TRL2	RS485	Enraf	Whessoe, GPE, Sakura, Tokyo Keiso	Analog out passive (non-IS)	Analog In passive (non-IS)
Secondary Fieldbus options	Code	R	4	E	H, G, U, T	B	7
TRL2	R	Yes	Yes	No	No	No	No
Enraf	E	Yes	Yes	No	No	No	No
WirelessHART®	W	Yes	Yes	Yes	Yes	Yes	Yes
L&J Tankway 1500 XL/MCG 2000	L	Yes	Yes	No	No	No	No
Varec Mark/Space GT 1800/1900	V	Yes	Yes	No	No	No	No
Whessoe WM 550/660 (digital current loop)	H	Yes	Yes	No	No	No	No
GPE 31422/31423 (digital current loop)	G	Yes	Yes	No	No	No	No
Sakura MDP/V1	U	Yes	Yes	No	No	No	No
Tokyo Keiso	T	Yes	Yes	No	No	No	No
Analog out active (IS)	C	Yes	Yes	Yes	No	No	No
Analog out active (non-IS)	A	Yes	Yes	Yes	No	No	No
Analog out passive (IS)	D	Yes	Yes	Yes	No	No	No
Analog out passive (non-IS)	B	Yes	Yes	Yes	No	No	No
Analog in active (IS)	8	Yes	Yes	Yes	No	No	No
Analog in active (non-IS)	6	Yes	Yes	Yes	No	No	No
Analog in passive (IS)	9	Yes	Yes	Yes	No	No	No
Analog in passive (non-IS)	7	Yes	Yes	Yes	No	No	No
None	0	Yes	Yes	Yes	No	No	No
Ready for upgrade	F	Yes	Yes	Yes	No	No	No

Yes = Primary Fieldbus and Secondary Fieldbus can be combined

No = Combination not possible

Table A-2: Fieldbus Combination Matrix (SIL)

		Primary Fieldbus options					
		TRL2	RS485	Enraf	Whessoe, GPE, Sakura, Tokyo Keiso	Analog out passive (non-IS)	Analog In passive (non-IS)
Secondary Fieldbus options	Code	R	4	E	H, G, U, T	B	7
TRL2	R	SIL 2 (relay)	SIL 2 (relay)	No	No	No	No
Enraf	E	SIL 2 (relay)	SIL 2 (relay)	No	No	No	No
WirelessHART	W	SIL 2 (relay)	SIL 2 (relay) or SIL 3 (relay)	SIL 2 (relay)	SIL 2 (relay)	SIL 2 (4-20 mA and/or relay)	SIL 2 (relay)
L&J Tankway 1500 XL/MCG 2000	L	SIL 2 (relay)	SIL 2 (relay)	No	No	No	No
Varec Mark/Space GT 1800/1900	V	SIL 2 (relay)	SIL 2 (relay)	No	No	No	No
Whessoe WM 550/660 (digital current loop)	H	SIL 2 (relay)	SIL 2 (relay)	No	No	No	No
GPE 31422/31423 (digital current loop)	G	SIL 2 (relay)	SIL 2 (relay)	No	No	No	No
Sakura MDP/V1	U	SIL 2 (relay)	SIL 2 (relay)	No	No	No	No
Tokyo Keiso	T	SIL 2 (relay)	SIL 2 (relay)	No	No	No	No
Analog out active (IS)	C	SIL 2 (4-20 mA and/or relay)	SIL 2 (relay) or SIL 3 (relay)	SIL 2 (4-20 mA and/or relay)	No	No	No
Analog out active (non-IS)	A	SIL 2 (4-20 mA and/or relay)	SIL 2 (4-20 mA and/or relay)	SIL 2 (4-20 mA and/or relay)	No	No	No
Analog out passive (IS)	D	SIL 2 (4-20 mA and/or relay)	SIL 2 (relay) or SIL 3 (relay)	SIL 2 (4-20 mA and/or relay)	No	No	No
Analog out passive (non-IS)	B	SIL 2 (4-20 mA and/or relay)	SIL 2 (4-20 mA and/or relay)	SIL 2 (4-20 mA and/or relay)	No	No	No
Analog in active (IS)	8	SIL 2 (relay)	SIL 2 (relay) or SIL 3 (relay)	SIL 2 (relay)	No	No	No
Analog in active (non-IS)	6	SIL 2 (relay)	SIL 2 (relay)	SIL 2 (relay)	No	No	No
Analog in passive (IS)	9	SIL 2 (relay)	SIL 2 (relay) or SIL 3 (relay)	SIL 2 (relay)	No	No	No
Analog in passive (non-IS)	7	SIL 2 (relay)	SIL 2 (relay)	SIL 2 (relay)	No	No	No
None	0	SIL 2 (relay) or SIL 3 (relay)	SIL 2 (relay) or SIL 3 (relay)	SIL 2 (relay) or SIL 3 (relay)	No	No	No
Ready for upgrade	F	SIL 2 (4-20 mA and/or relay)	SIL 2 (4-20 mA and/or relay)	SIL 2 (4-20 mA and/or relay)	No	No	No

SIL = Primary Fieldbus and Secondary Fieldbus can be combined with SIL

No = Combination not possible

Table A-3: Fieldbus Combination Matrix (Rosemount 2410:SIS)

		Primary Fieldbus options		
		TRL2	RS485	Analog out passive (non-IS)
Secondary Fieldbus options	Code	R	4	B
TRL2	R	SIL 2 (relay)	SIL 2 (relay)	No
WirelessHART	W	SIL 2 (relay)	SIL 2 (relay)	SIL 2 (4-20 mA and/or relay)
Analog out active (IS)	C	SIL 2 (4-20 mA and/or relay)	SIL 2 (4-20 mA and/or relay)	No
Analog out active (non-IS)	A	SIL 2 (4-20 mA and/or relay)	SIL 2 (4-20 mA and/or relay)	No
Analog out passive (IS)	D	SIL 2 (4-20 mA and/or relay)	SIL 2 (relay) or SIL 3 (relay)	No
Analog out passive (non-IS)	B	SIL 2 (4-20 mA and/or relay)	SIL 2 (4-20 mA and/or relay)	No
None	0	SIL 2 (relay)	SIL 2 (relay)	No
Ready for upgrade	F	SIL 2 (4-20 mA and/or relay)	SIL 2 (4-20 mA and/or relay)	No

SIL = Primary Fieldbus and Secondary Fieldbus can be combined with SIL

No = Combination not possible

A.2.6 Integral display output variables

The integral digital read-out display can toggle between:

- Level
- Level rate
- Ullage
- Signal strength
- Volume (TOV)
- Liquid average temperature
- 1-16 spot temperature
- Vapor average temperature
- Ambient temperature
- Free water level
- Vapor pressure
- Liquid pressure
- Air pressure
- Observed density
- Reference density
- Flow rate

A.2.7 Display output units

Level, free water level, and ullage:	meter, millimeter, feet, or imperial 1/16
Level rate:	meter/second, meter/hour, feet/second, or feet/hour
Flow rate:	meter ³ /hour, liter/minute, barrel/hour, or US gallon/hour
Total Observed Volume (TOV):	meter ³ , liters, barrel, or US gallon
Temperature:	°F, °C, or °K
Pressure:	psi, psiA, psiG, bar, barA or barG, atm, Pa, or kPa
Density:	kg/m ³ , °API, or 60/60DegF
Signal strength:	mV

Density, mass, and more volume parameters are calculated in Rosemount TankMaster (GOV, GSV, NSV, WIA/WIV).

A.2.8 Configuration tools

Rosemount TankMaster

A.2.9 Autoconfiguration support

Yes (Tankbus addressing)

A.3 Electrical specifications

A.3.1 Power supply (nominal values)

24-48 Vdc (-15% to +10%) 48-240 Vac (-15% to +10%), 50/60 Hz

A.3.2 Power consumption

Max. 20 W depending on configuration.

Recommended Miniature Circuit Breaker (MCB): 2A slow

A.3.3 Tankbus cabling

0.5-1.5 mm² (AWG 22-16), twisted shielded pairs. Recommended cabling is shielded twisted pairs, 0.75 mm² (AWG 18). Tankbus cabling must fulfill FISCO cable and installation requirements, and must also be approved for use at minimum 85 °C (185 °F).

FISCO (Fieldbus Intrinsically Safe Concept)

The following cable characteristics are specified for FISCO:

Table A-4: FISCO Cable Parameters

Parameter ⁽¹⁾	Value
Loop resistance	15 Ω/km to 150 Ω/km
Loop inductance	0.4 mH/km to 1 mH/km
Capacitance	45 nF/km to 200 nF/km
Maximum length of each spur ⁽²⁾ cable	60 m in apparatus class IIC and IIB
Maximum cable length including trunk ⁽³⁾ and spurs	1000 m in apparatus class IIC and 1900 m in apparatus class IIB

(1) For further information see requirements of the IEC 61158-2 standard.

(2) A spur is an unterminated part of the network.

(3) A trunk is the longest cable path between two devices on the fieldbus network, and is the part of the network which has terminations at both ends. In the Rosemount Tank Gauging system, a trunk is typically located between the Rosemount 2410 Tank Hub and a segment coupler or the last device in a daisy-chain configuration.

Power budget

Table A-5: Power Consumption for Various Rosemount Tank Gauging Devices

Field device	Power consumption
Rosemount 5900S Radar Level Gauge	50 mA
Rosemount 5900C Radar Level Gauge	50 mA
Rosemount 5900S Radar Level Gauge, 2-in-1 solution	100 mA
Rosemount 5300 Level Transmitter	21 mA
Rosemount 5408 Level Transmitter	21 mA
Rosemount 2230 Graphical Field Display	30 mA
Rosemount 2240S Multi-input Temperature Transmitter	30 mA including 565, 566 and 765 temperature sensors
Rosemount 3144P Temperature Transmitter	12 mA
Rosemount 3051S, and Rosemount 2051 Pressure Transmitters	18 mA

Allowed cabling distances

Figure A-9: Cable Distances

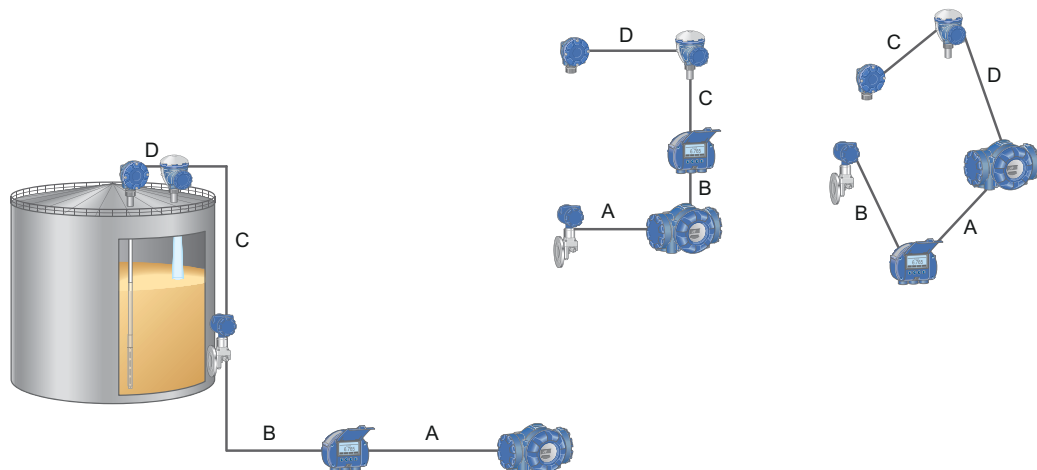

The total cable distance $A+B+C+D$ must not exceed the values given in [Table A-6](#).

Table A-6: Allowed Cabling Distances for Different System Configurations

Cable diameter	Loop resistance	Maximum cabling distance from power source to all devices on the tank		
		With maximum power usage of 250 mA Distance in m (ft)	With typical power usage of 128 mA for 5900S, 2240S, 2230, 3051S Distance in m (ft)	With typical power usage of 178 mA for 5900S 2-in-1, 2240S, 2230, 3051S Distance in m (ft)
20 AWG (0.5 mm ²)	66 Ω/km	212 (695)	414 (1358)	298 (978)
18 AWG (0.75 mm ²)	42 Ω/km	333 (1092)	651 (2136)	468 (1535)
17 AWG (1.0 mm ²)	33 Ω/km	424 (1391)	829 (2720)	596 (1955)
16 AWG (1.5 mm ²)	26 Ω/km	538 (1765)	1000 (3281)	756 (2480)

The typical cabling distance from the tank hub toward the control room is up to 4 km (2.5 miles) depending on which protocol is used.

A.3.4 Power and relay cabling

0.5-2.5 mm² (AWG 22-14), twisted shielded pairs

A.3.5 Maximum Tankbus cable lengths

Depends on the cable. For details, see the Rosemount Tank Gauging [System Data Sheet](#).

A.3.6 Built-in Tankbus terminator

The Rosemount 2410 Tank Hub has a built-in tank bus terminator, which can be disconnected if required.

A.4 Mechanical specifications

A.4.1 Housing material

Polyurethane-covered die-cast aluminum

A.4.2 Cable entry (connection/glands)

Non-IS side: Two ½ - 14 NPT and Two ¾ - 14 NPT entries for cable glands or conduits

IS side: Two ½ - 14 NPT entries for cable glands or conduits

Three metal plugs to seal any unused ports are included in the delivery

Optional:

- M20 x 1.5 and M25 x 1.5 conduit/cable adapter
- Cable glands in metal (½ - 14 NPT and ¾ - 14 NPT)
- 4-pin male eurofast connector or A size Mini 4-pin male minifast connector

A.4.3 Installation

Can be installed on a 33.4-60.3 mm (1-2 in.) diameter pipe or wall, at ground level close to the tank or on top of the tank using existing cabling.

A.4.4 Weight

4.7 kg (10.4 lbs)

A.5 Environmental specifications

A.5.1 Temperature limits

Ambient temperature

-40 to 70 °C (-40 to 158 °F). Minimum start-up temperature is -50 °C (-58 °F).

With LCD display: -25 to 70 °C (-13 to 158 °F)

Storage temperature

-50 to 85 °C (-58 to 185 °F)

With LCD display: -40 to 85 °C (-40 to 185 °F)

A.5.2 Humidity

0 - 100% relative humidity

A.5.3 Ingress protection

IP 66 and IP 67 (NEMA® 4X)

A.5.4 Metrology sealing possibility

Yes

A.5.5 Write-protect switch

Yes (hardware and software write-protection)

A.5.6 Transient/built-in lightning protection

In accordance with IEC 61000-4-5, level 4 kV line to ground.

A.6 Dimensional drawings

Figure A-10: Rosemount 2410 Tank Hub Dimensions

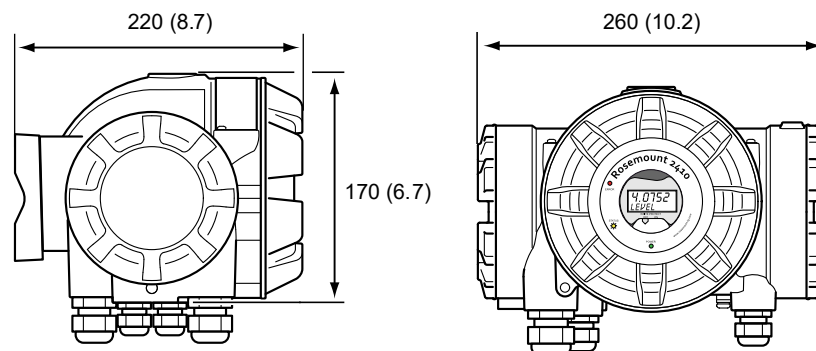

Dimensions are in millimeters (inches).

A.7 Ordering information

A.7.1 Specifications and options

Specification and selection of product materials, options, and/or components must be made by the purchaser of the equipment. See the Material selection section for more information.

A.7.2 Model codes

Model codes contain the details related to each product. Exact model codes will vary; an example of a typical model code is shown in [Figure A-11](#).

Figure A-11: Model Code Example

2410SFR0321PSE1RA1P	WR3ST
<hr/>	<hr/>
1	2

1. Required model components (choices available on most)
2. Additional options (variety of features and functions that may be added to products)

A.7.3 Rosemount 2410 Tank Hub

Required model components Model

Code	Description
2410	Tank Hub

Tankbus: number of tanks

Code	Description
S ⁽¹⁾	Single tank
M ⁽²⁾	Multiple tanks (up to ten level devices per tank hub)

(1) Supports one Rosemount 5900S 2-in-1 gauge or up to two Rosemount 5900 standard gauges.

(2) Up to five Rosemount 5300, up to 10 Rosemount 5408 per tank hub.

Tankbus: power and communication

Code	Description
F	Intrinsically safe FOUNDATION™ Fieldbus (IEC 61158) power supply

Primary fieldbus

Code	Description
R	TRL2 Modbus
4	RS485 Modbus
E	Enraf® Bi-phase Mark GPU
H ⁽¹⁾	Whessoe WM 550/660 (digital current loop)
G ⁽¹⁾	GPE 31422/31423 (digital current loop)
U ⁽¹⁾	Sakura (MDP/V1)
T ⁽¹⁾	Tokyo Keiso
B ⁽¹⁾	Analog output 4-20 mA/HART®, passive (non-IS)
7 ⁽¹⁾	Analog input 4-20 mA/HART®, passive (non-IS)

(1) Requires Secondary fieldbus code W.

Secondary fieldbus

Code	Description
R ⁽¹⁾	TRL2 Modbus
E ⁽¹⁾	Enraf® Bi-phase Mark GPU
W ⁽²⁾⁽³⁾	WirelessHART® (IEC 62591) connectivity (IS)
L ⁽¹⁾	L&J Tankway Slave 1500 XL/MCG 2000
V ⁽¹⁾	Varec® Mark/Space GT 1800/1900

Code	Description
H ⁽¹⁾	Whessoe WM 550/660 (digital current loop)
G ⁽¹⁾	GPE 31422/31423 (digital current loop)
U ⁽¹⁾	Sakura (MDP/V1)
T ⁽¹⁾	Tokyo Keiso
C ⁽³⁾⁽⁴⁾	Analog output 4-20 mA/HART, active (IS)
A ⁽³⁾⁽⁴⁾	Analog output 4-20 mA/HART, active (non-IS)
D ⁽⁴⁾	Analog output 4-20 mA/HART, passive (IS)
B ⁽⁴⁾	Analog output 4-20 mA/HART, passive (non-IS)
8 ⁽³⁾⁽⁴⁾	Analog input 4-20 mA/HART, active (IS)
6 ⁽³⁾⁽⁴⁾	Analog input 4-20 mA/HART, active (non-IS)
9 ⁽⁴⁾	Analog input 4-20 mA/HART, passive (IS)
7 ⁽⁴⁾	Analog input 4-20 mA/HART, passive (non-IS)
0 ⁽⁴⁾	None
F ⁽⁴⁾	None, ready for upgrade of secondary bus

- (1) Requires Primary fieldbus code R or 4.
- (2) Requires a separate Emerson Wireless 775 THUM Adapter (not included, to be ordered as a separate item).
- (3) Power-supply integrated. Maximum Tankbus current reduced to 200 mA.
- (4) Requires Primary fieldbus code R, 4 or E.

Safety certification (SIS)

Code	Description
3 ⁽¹⁾⁽²⁾	Certified IEC 61508 SIL 3 (Using relay 1xSPST, solid-state. Certification is valid only when connected to a safety-certified Rosemount 5900 according to reference manual).
S ⁽²⁾⁽³⁾	Certified IEC 61508 SIL 2 (using analog or relay output)
F ⁽²⁾⁽³⁾⁽⁴⁾	None, ready for upgrade of safety certification (SIS)
0	None

- (1) Requires Secondary fieldbus code 0, or Secondary fieldbus code W, C, D, 8, 9, and Primary fieldbus code 4.
- (2) Requires Number of tanks code S.
- (3) Requires Relay output code 2 or 1, or Primary fieldbus Code B, or Secondary fieldbus code A, B, C or D for SIL 2 (Safety certification code S).
- (4) Requires Secondary fieldbus code 0 or F for SIL3 (Safety certification code 3).

Relay output

Code	Description
2	2xSPST, solid-state
1	1xSPST, solid-state
F	None, ready for upgrade of relay output
0	None

Integral display

Code	Description
1	LCD
0	None

Power supply

Code	Description
P	Extended input range: 48-240 Vac at 50/60 Hz, and 24-48 Vdc

Firmware

Code	Description
S	Standard

Hazardous location certification

Code	Description
E1	ATEX Flameproof
E7	IECEX Flameproof
E5	FM-US Explosion-proof
E6	FM-Canada Explosion-proof
E4	Japan Flameproof
E2	INMETRO Flameproof (Brazil)
E3	China Flameproof
EP ⁽¹⁾	KC Flameproof (South Korea)
EW	CCOE/PESO Flameproof Certification (India)
EM	Technical Regulations Customs Union (EAC) Flameproof
NA	No hazardous location certification

(1) Requires Custody transfer type approval code R or O.

Custody transfer type approval

Requires a Rosemount 5900S Radar Level Gauge with corresponding Custody transfer type approval.

Code	Description
R	OIML R85 E 2008 performance certification
A	CMI (Czech Republic W&M approval)
B	NMI (Australia)
C	PTB (German W&M approval)
E	TJA (Estonia W&M approval)
I	Ministero (Italy)
K ⁽¹⁾	GOST (Kazakhstan)
L	LNE (France)
M	BMS (Belgium W&M)
N	NMi (the Netherlands W&M approval)
O	ONML (Algeria)
Q	IPQ (Portugal)
T	ANM (Tunisia)
V	BEV (Austria)
W	METAS (Switzerland W&M approval)
0	None

(1) Requires Hazardous location certification code E1.

Housing

Code	Description
A	Aluminum (polyurethane-covered), IP 66/67

Cable/conduit connections

Code	Description	Includes
1	½-14 NPT and ¾-14 NPT, female thread	<ul style="list-style-type: none"> 1 pcs ½-14 NPT plug 2 pcs ¾-14 NPT plugs
2	M20 x 1.5 and M25 x 1.5 adapters, female thread	<ul style="list-style-type: none"> 1 pcs ½-14 NPT plug 2 pcs ¾-14 NPT plugs 4 pcs ½-14 NPT->M20 x 1.5 adapters 2 pcs ¾-14 NPT->M25 x 1.5 adapters
G ⁽¹⁾	Metal cable glands (½-14 and ¾-14 NPT)	<ul style="list-style-type: none"> 1 pcs ½-14 NPT plug 2 pcs ¾-14 NPT plugs 4 pcs ½-14 NPT cable glands 2 pcs ¾-14 NPT cable glands
E	eurofast® male connector	<ul style="list-style-type: none"> 1 pcs male connector
M	minifast® male connector	<ul style="list-style-type: none"> 1 pcs ½-14 NPT plug 2 pcs ¾-14 NPT plugs

(1) Minimum temperature -20 °C (-4 °F). ATEX/IECEX Ex e approved.

Mechanical installation

Code	Description
W	Mounting kit for wall installation
P	Mounting kit for both wall and pipe installation (1-2-in. vertical or horizontal pipes)

Additional options Safety certificate

Requires Safety certification (SIS) code S or 3.

Code	Description
QT	IEC 61508 certificate and FMEDA data

Conformance certificate

Code	Description
Q1	Printed copy of certificate of conformance

Hazardous location certificate

Code	Description
Q7	Printed copy of hazardous location certificate

Overfill protection approval

Requires Safety certification (SIS) code 3, or Relay output code 1 or 2.

Code	Description
U1	TÜV/DIBt WHG approval for overfill protection
U2	SVTI approval for overfill protection (Switzerland)

Tag plate

Code	Description
ST	Engraved SST tag plate (tag shall be submitted with order)

Extended product warranty

Rosemount extended warranties have a limited warranty of three or five years from date of shipment.

Code	Description
WR3	3-year limited warranty
WR5	5-year limited warranty

A.7.4 Rosemount 2410:SIS Tank Hub

Required model components Model

Code	Description
2410	Tank Hub

Tankbus: number of tanks

Code	Description
F ⁽¹⁾	Functional safety / SIS applications (SIL 2 single tank)

(1) Supports one Safety Certified Rosemount 5900 level gauge.

Tankbus: power and communication

Code	Description
F	Intrinsically safe FOUNDATION™ Fieldbus (IEC 61158) power supply

Primary fieldbus

Code	Description
R	TRL2 Modbus
4	RS485 Modbus
B ⁽¹⁾	Analog output 4-20 mA/HART®, passive (non-IS)

(1) Requires Secondary fieldbus code W.

Secondary fieldbus

Code	Description
R ⁽¹⁾	TRL2 Modbus
W ⁽²⁾⁽³⁾	WirelessHART® (IEC 62591) connectivity (IS)
C ⁽¹⁾⁽³⁾	Analog output 4-20 mA/HART, active (IS)
A ⁽¹⁾⁽³⁾	Analog output 4-20 mA/HART, active (non-IS)
D ⁽¹⁾	Analog output 4-20 mA/HART, passive (IS)
B ⁽¹⁾	Analog output 4-20 mA/HART, passive (non-IS)
0 ⁽¹⁾	None
F ⁽¹⁾	None, ready for upgrade of secondary bus

(1) Requires Primary fieldbus code R or 4.

(2) Requires a separate Emerson Wireless 775 THUM Adapter (not included, to be ordered as a separate item).

(3) Power-supply integrated. Maximum Tankbus current reduced to 200 mA.

Safety certification (SIS)

Code	Description
S ⁽¹⁾	Certified IEC 61508 SIL 2 (using analog or relay output)

(1) Requires Relay output code 2 or 1, or Primary fieldbus Code B, or Secondary fieldbus code A, B, C or D for SIL 2 (Safety certification code S).

Relay output

Code	Description
2	2xSPST, solid-state
1	1xSPST, solid-state
F	None, ready for upgrade of relay output
0	None

Integral display

Code	Description
1	LCD
0	None

Power supply

Code	Description
P	Extended input range: 48-240 Vac at 50/60 Hz, and 24-48 Vdc

Firmware

Code	Description
S	Standard

Hazardous location certification

Code	Description
E1	ATEX Flameproof
E7	IECEX Flameproof
E5	FM-US Explosion-proof
E6	FM-Canada Explosion-proof
E4	Japan Flameproof
E2	INMETRO Flameproof (Brazil)
E3	China Flameproof
EP ⁽¹⁾	KC Flameproof (South Korea)
EW	CCOE/PESO Flameproof Certification (India)

Code	Description
EM	Technical Regulations Customs Union (EAC) Flameproof
NA	No hazardous location certification

(1) Requires Custody transfer type approval code 0.

Custody transfer type approval

Requires a Rosemount 5900S Radar Level Gauge with corresponding Custody transfer type approval.

Code	Description
0	None

Housing

Code	Description
A	Aluminum (polyurethane-covered), IP 66/67

Cable/conduit connections

Code	Description	Includes
1	½-14 NPT and ¾-14 NPT, female thread	<ul style="list-style-type: none"> 1 pcs ½-14 NPT plug 2 pcs ¾-14 NPT plugs
2	M20 x 1.5 and M25 x 1.5 adapters, female thread	<ul style="list-style-type: none"> 1 pcs ½-14 NPT plug 2 pcs ¾-14 NPT plugs 4 pcs ½-14 NPT->M20 x 1.5 adapters 2 pcs ¾-14 NPT->M25 x 1.5 adapters
G ⁽¹⁾	Metal cable glands (½-14 and ¾-14 NPT)	<ul style="list-style-type: none"> 1 pcs ½-14 NPT plug 2 pcs ¾-14 NPT plugs 4 pcs ½-14 NPT cable glands 2 pcs ¾-14 NPT cable glands
E	eurofast® male connector	<ul style="list-style-type: none"> 1 pcs male connector
M	minifast® male connector	<ul style="list-style-type: none"> 1 pcs ½-14 NPT plug 2 pcs ¾-14 NPT plugs

(1) Minimum temperature -20 °C (-4 °F). ATEX/IECEX Ex e approved.

Mechanical installation

Code	Description
W	Mounting kit for wall installation
P	Mounting kit for both wall and pipe installation (1-2-in. vertical or horizontal pipes)

Additional options Safety certificate

Requires Safety certification (SIS) code S.

Code	Description
QT	IEC 61508 certificate and FMEDA data

Conformance certificate

Code	Description
Q1	Printed copy of certificate of conformance

Hazardous location certificate

Code	Description
Q7	Printed copy of hazardous location certificate

Overfill protection approval

Requires Relay output code 1 or 2.

Code	Description
U1	TÜV/DIBt WHG approval for overfill protection
U2	SVTI approval for overfill protection (Switzerland)

Tag plate

Code	Description
ST	Engraved SST tag plate (tag shall be submitted with order)

Extended product warranty

Rosemount extended warranties have a limited warranty of three or five years from date of shipment.

Code	Description
WR3	3-year limited warranty
WR5	5-year limited warranty

B Advanced configuration

B.1 Safety messages

Instructions and procedures in this section may require special precautions to ensure the safety of the personnel performing the operations. Information that potentially raises safety issues is indicated by a warning symbol (⚠). Refer to the following safety messages before performing an operation preceded by this symbol.

⚠ WARNING

Failure to follow safe installation and servicing guidelines could result in death or serious injury.

Ensure only qualified personnel perform the installation.

Use the equipment only as specified in this manual. Failure to do so may impair the protection provided by the equipment.

Do not perform any services other than those contained in this manual unless you are qualified.

Any substitution of non-recognized parts may jeopardize safety. Repair (e.g. substitution of components) may also jeopardize safety and is not allowed under any circumstances.

⚠ WARNING

Explosions could result in death or serious injury.

Verify that the operating atmosphere of the transmitter is consistent with the appropriate hazardous locations certifications.

Before connecting a handheld communicator in an explosive atmosphere, ensure that the instruments in the loop are installed in accordance with intrinsically safe or non-incendive field wiring practices.

Do not remove the gauge cover in explosive atmospheres when the circuit is alive.

To prevent ignition of flammable or combustible atmospheres, disconnect power before servicing.

⚠ WARNING

High voltage that may be present on leads could cause electrical shock.

Avoid contact with leads and terminals.

Ensure the main power to the Rosemount 2410 Tank Hub is off and the lines to any other external power source are disconnected or not powered while wiring the device.

B.2 Extended configuration options in WinSetup

There are configuration options for the Rosemount™ 2410 Tank Hub which are not included in the TankMaster WinSetup installation wizard. These options are available via the **Properties** option in the WinSetup configuration software.

Procedure

1. In the **TankMaster WinSetup** workspace, right-click the Rosemount 2410 Tank Hub icon.
2. Choose the **Properties** option.
The **2410 Tank Hub** window appears.
3. Select the **Configuration** tab.

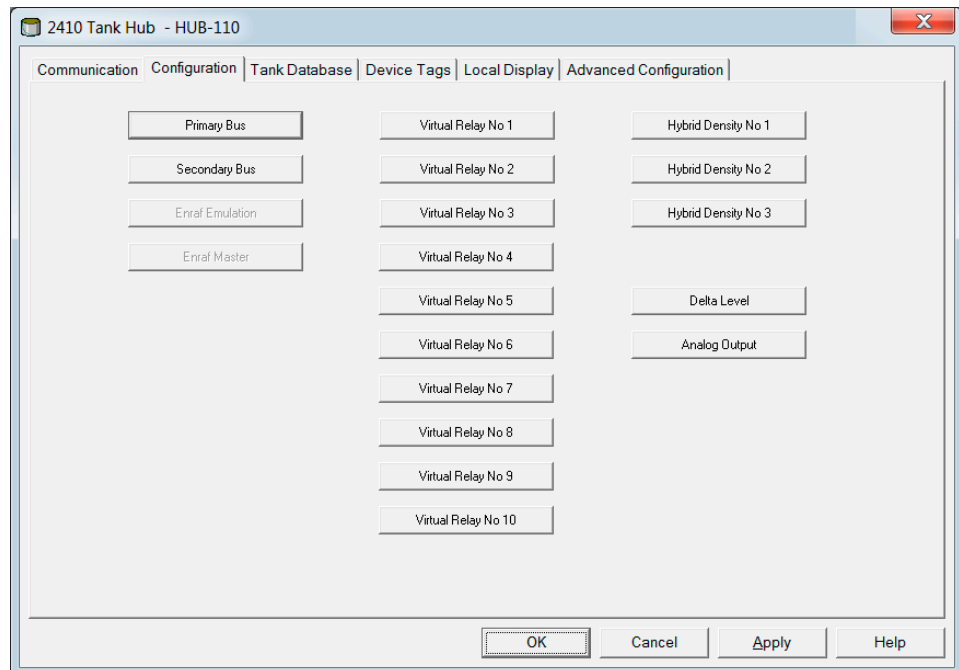

The **Configuration** window contains buttons for Primary and Secondary Bus, Virtual Relays, and Hybrid Density calculation.

Related information

[Change the communication parameters for the primary bus](#)

[Open the secondary bus window](#)

[Configure a virtual relay output](#)

[Set up a Rosemount 2410 for hybrid density applications](#)

B.3 Change the communication parameters for the primary bus

The Rosemount 2410 has a Primary Bus which is used for communication with a Rosemount 2460 System Hub. It may also be connected directly to a control room PC. The Primary Bus supports TRL2, RS485, and other communication buses. The Rosemount 2410 automatically detects what modem is installed in the Primary Bus slot and communication parameters are set accordingly. For some modem types (such as RS485) the non standard

option allows you to configure communication with other protocols than the standard Modbus®.

Procedure

1. Open the **Primary Bus** window.
 - a) In the **TankMaster WinSetup** workspace, right-click the Rosemount 2410 Tank Hub icon.
 - b) Choose the **Properties** option.
The **2410 Tank Hub** window appears.
 - c) Select the **Configuration** tab.
 - d) Click the **Primary Bus** button.

The **Primary Bus Configuration** window lets you configure protocol, baudrate, and other communication parameters when the standard settings are not appropriate.

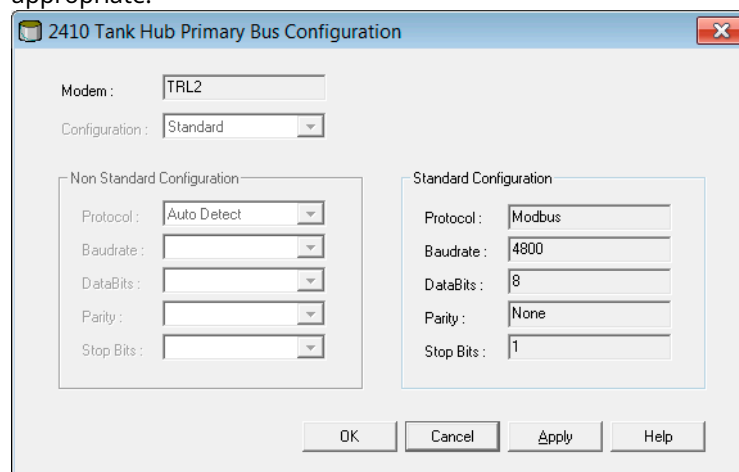

2. To change communication parameters:
 - a) In the **Configuration** drop-down menu, change from **Standard** to **Non Standard**.
 - b) Choose the desired Protocol.
 - c) Choose appropriate communication parameter values for Baudrate, Databits, Parity, and Stop Bits.
 - d) Click **Apply** to store the current configuration, or click **OK** to store the configuration and close the **Primary Bus Configuration** window.

B.4 Open the secondary bus window

The Rosemount 2410 Secondary Bus is used for communication with emulated devices. It supports many different modems and protocols such as the TRL2 Modbus, Enraf, Varec, and L&J.

Procedure

1. In the **TankMaster WinSetup** workspace, right-click the Rosemount 2410 Tank Hub icon.

2. Choose the **Properties** option.
The **2410 Tank Hub** window appears.
3. Select the **Configuration** tab.
4. Click the **Secondary Bus** button.

The **Secondary Bus Configuration** window allows you to change protocol, baudrate, address, and other communication settings.

2410 Tank Hub Secondary Bus Configuration

Modem : Enraf BPM

Configuration : Standard

Non Standard Configuration

Protocol : Auto Detect

Baudrate :

DataBits :

Parity :

Stop Bits :

Standard Configuration

Protocol : Enraf

Baudrate : 1200

DataBits : 7

Parity : Odd

Stop Bits : 1

OK Cancel Apply Help

B.5 Configure a virtual relay output

The Rosemount 2410 has two relays which can be configured with one or two set points. Virtual relay output, (Disabled, Relay1, Relay2), source, set-point etc. can also be specified.

The Rosemount 2410 Tank Hub supports virtual relay functionality that lets you specify up to ten source parameters to control the two hardware relays. The output of a virtual relay can be directed towards any of the two relays, allowing a high configuration flexibility. You may, for example, use one of the relays (Relay1 or Relay2) as a high level alarm for several tanks by using Level as source parameter for each tank. Many other configurations are possible using the two relays for various virtual relay configurations.

Procedure

1. In the **TankMaster WinSetup** workspace, right-click the Rosemount 2410 icon.
2. Choose the **Properties** option.
The **2410 Tank Hub** window appears.
3. Select the **Configuration** tab.
4. Click one of the **Virtual Relay No.** buttons.

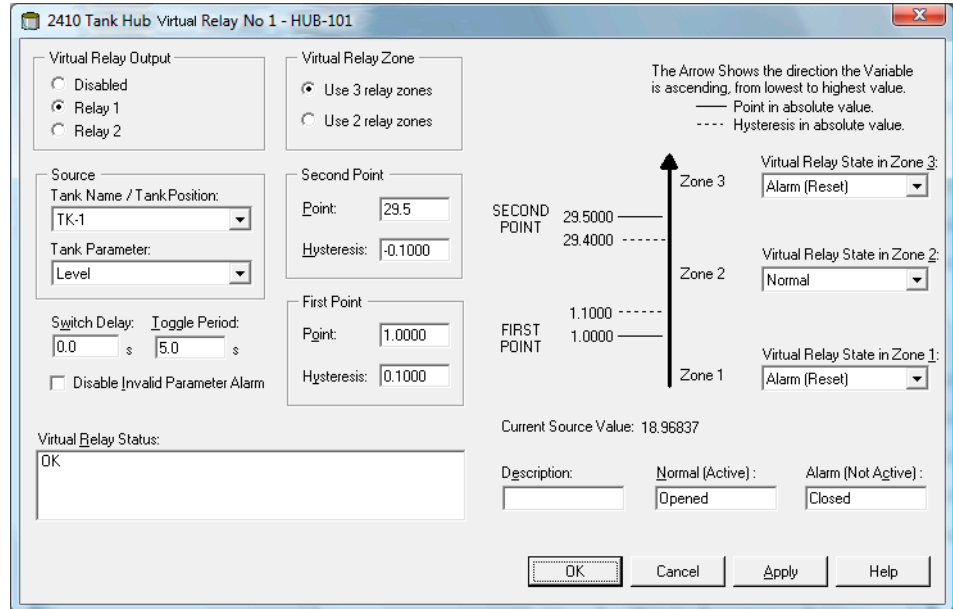

B.5.1 Using two/three relay zones

You may use two or three relay zones. Different relay states can be used in each of these zones.

With two relay zones, use one set point: First Point.

With three relay zones, use two set points: First Point and Second Point.

B.5.2 First and second set points

The first and second set points define the transitions between Zone 1, 2 and 3. You can set different relay states in each of these zones.

First Point defines the transition between Zone 1 and 2.

Second Point defines the transition between Zone 2 and 3.

B.5.3 Hysteresis

When the source variable passes a set point, the relay switches from one state to the other. When the source signal returns back into the previous zone, the relay does not switch back to the previous state until it has passed both the set point and the hysteresis zone.

B.5.4 Virtual relay states

There are three virtual relay states available:

Table B-1: Rosemount 2410 Relay States

Virtual Relay State	Description
Alarm	In the Alarm state the relay is de-energized. Depending on how the relays are connected, they will be either open or closed in the de-energized state. Note that a relay defined as Normally Open will be open in the Alarm state. If the relay is configured as Normally Closed it will be closed in the Alarm state.
Normal	In the Normal state the relay is energized.
Toggle	The relay switches periodically between Normal and Alarm

The Virtual Relay Output setting determines whether the relays are active or disabled.

Table B-2: Rosemount 2410 Relay Control Modes

Virtual Relay Output	Description
Disabled	The relay function is turned off.
Relay 1/Relay 2	Specifies the actual relay that the Relay Output is connected to. The Rosemount 2410 Tank Hub can be equipped with one or two relays.

B.5.5 Source

Specifies the measurement variable that triggers the relay switching.

“Tank Name/Tank Position” refers to the tank position in the Rosemount 2410 tank database. The tank database maps all devices connected to the Rosemount 2410 Tank Hub to the specific tanks, see the Rosemount Tank Gauging [System Configuration Manual](#) for more information about configuration of the Rosemount 2410 tank database.

Tank Parameter refers to the measurement variable that triggers the relay switching. For example, Level, Delta_Level, Ullage or any other variable can be chosen as source.

B.5.6 Switch delay

This is the delay time for the relay to switch into alarm state, i.e. the amount of time it takes for a relay to respond to an alarm. You can use this parameter to prevent the relay from switching due to small temporary variations of the source signal. This may for example occur if there is a turbulent product surface.

B.5.7 Toggle period

When the relay is in Toggle state it switches between On and Off at a rate defined by the Toggle Period.

B.5.8 Relay output configuration

The relay output can be selected as either Normally Open or Normally Closed referring to the contact position when the relay is de-energized. This also refers to the Alarm (Reset) state.

The relay terminology can be summarized as shown in [Table B-3](#):

Table B-3: Relay state terminology

Normally Closed		Normally Open	
Closed	Open	Open	Closed
De-energized	Energized	De-energized	Energized
Not Active	Active	Not Active	Active
Alarm (Reset)	Normal	Alarm (Reset)	Normal

Related information

[Relay output configuration](#)

B.5.9 Relay zones

You can use one or two set points for relays connected to the Rosemount 2410 Tank Hub. Consequently, there are two or three zones in which different relay states can be specified. For each zone you can set any of the three available relay states Normal, Alarm or Toggle.

For each set point you can specify a hysteresis zone preventing the relay from switching back to its previous state as long as the source variable is changed only small amounts around a certain set point. The principle of relay set points and hysteresis zones is shown in the figure below. Note that in this example only two states are used.

Figure B-1: Relay Zones

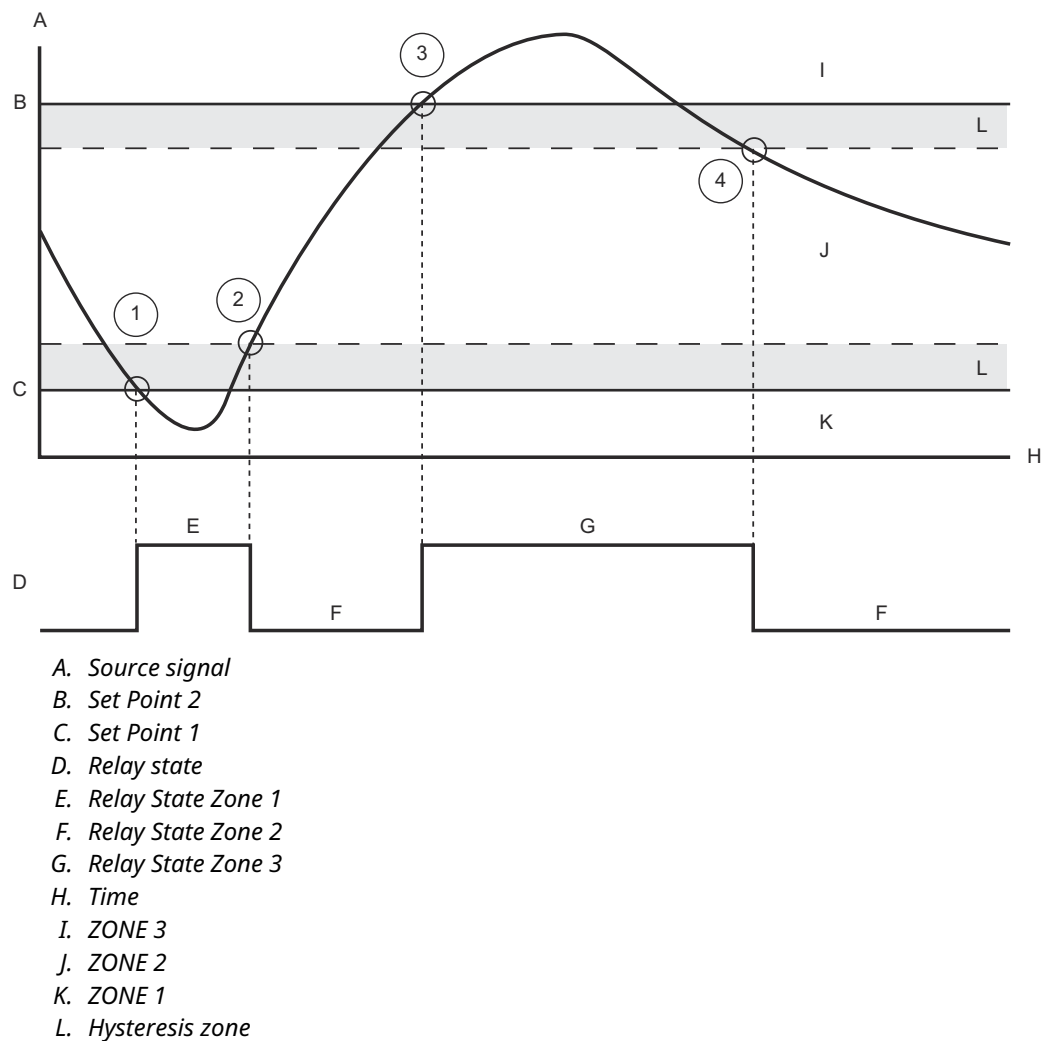

1. The source signal passes set point 1, and the relay state changes according to the definition for Zone 1.
2. When the source signal returns into Zone 2, it does not change to the Zone 2 state until it has passed the hysteresis zone.
3. The source signal passes set point 2, and the relay state is changed according to the definition for Zone 3.
4. The relay switches back to the Zone 2 relay state when the source signal has passed set point 2 and the associated hysteresis value.

B.6 Set up a Rosemount 2410 for hybrid density applications

The Rosemount TankMaster software can be used in a hybrid density system to calculate Observed Density. Density calculations are also available for a host system connected

directly to a Rosemount 2410 without using TankMaster. Then the density calculations are performed internally by the Rosemount 2410 Tank Hub.

Procedure

1. Install and connect the devices on the tank including the Vapor Pressure sensor (P3) and the Liquid Pressure sensor (P1).
2. Start the TankMaster Winsetup configuration program.
3. Configure the Rosemount 2410 Tank Hub⁽¹⁷⁾. Ensure that the appropriate devices are associated with the current tank in the Rosemount 2410 tank database as illustrated below.

Example

In the example below a Rosemount 5900S Radar Level Gauge, a Rosemount 2240S Multi-input Temperature Transmitter, and two Rosemount 3051S Pressure Transmitters (P1 and P3) are installed on the tank.

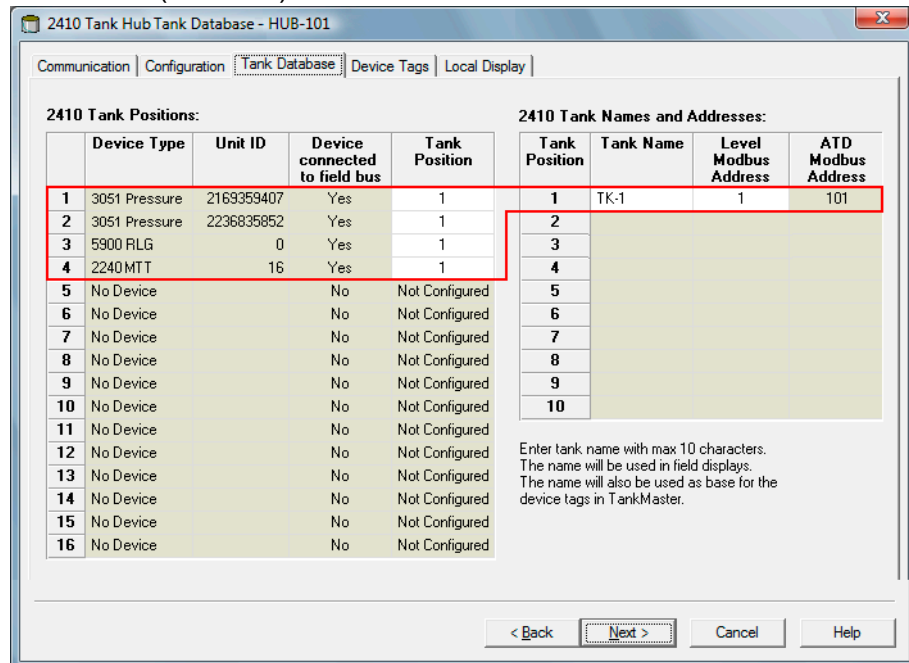

4. Configure the Rosemount 5900S Radar Level Gauge⁽¹⁷⁾.
5. Configure the Auxiliary Tank Devices⁽¹⁷⁾ (Rosemount 2240S Multi-input Temperature Transmitter).
6. In the **22XX ATD/Advanced Parameter Source Configuration** window, ensure that the Vapor Pressure (P3) and Liquid Pressure (P1) parameters are mapped to the actual source devices on the tank as shown below.

In case there is no vapor pressure sensor installed, a manual value can be used instead.

⁽¹⁷⁾ See the Rosemount Tank Gauging [System Configuration Manual](#) for more information.

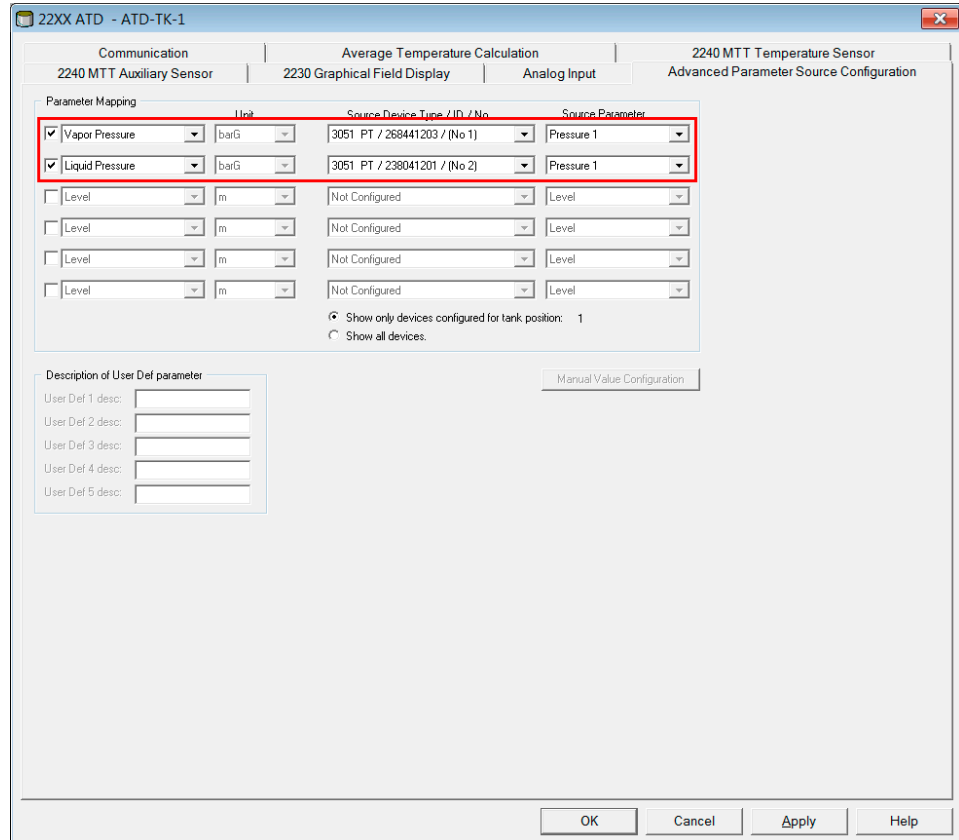

7. Configure the Hybrid Density function, see [Hybrid density configuration](#).
8. Configure the tank as described in the Rosemount Tank Gauging System Configuration Manual.

B.6.1 Hybrid density configuration

To configure the hybrid density function do the following:

Procedure

1. In the **TankMaster WinSetup** workspace, right-click the Rosemount 2410 icon.
2. Choose the **Properties** option.
The **2410 Tank Hub** window appears.
3. Select the **Configuration** tab.
4. Click the **Hybrid Density No. [X]** button to open the **2410 Tank Hub Hybrid Density Configuration** window. Up to three tanks can be configured for Hybrid Density calculations.

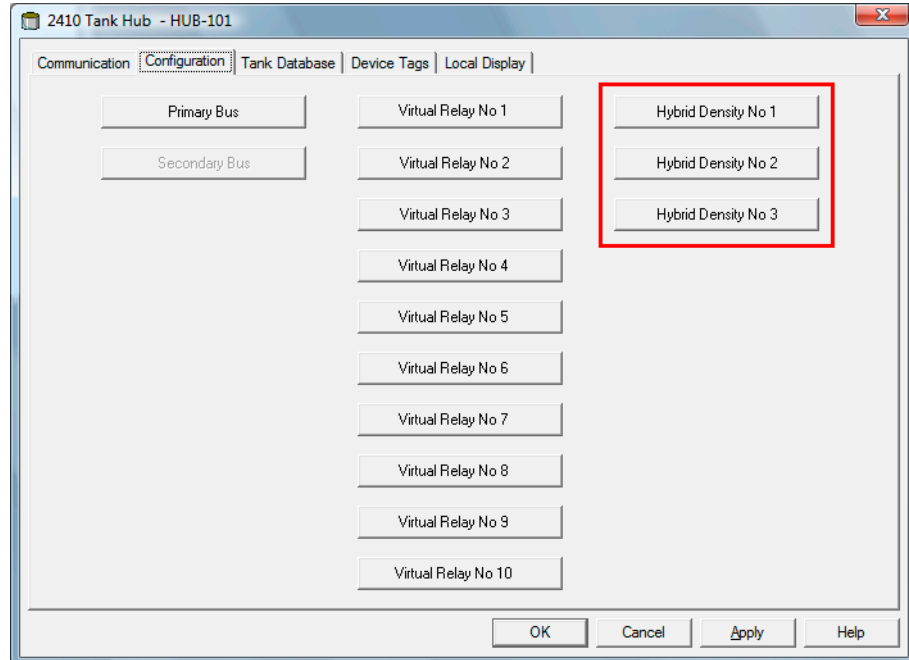

- From the **Tank Name/Hub Position** drop-down list select the tank to be configured for hybrid density calculations.

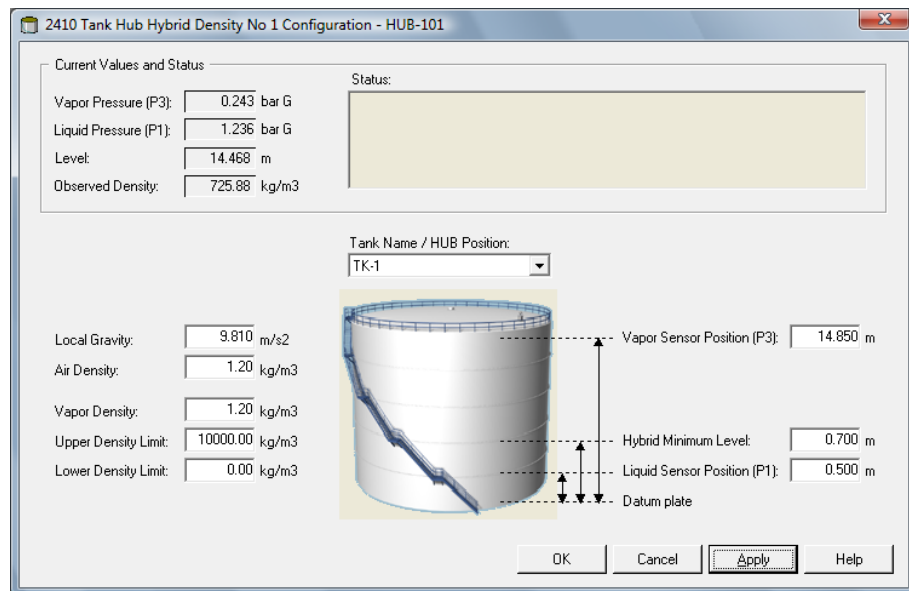

- Enter Local Gravity, Air Density and Vapor Density. These parameters are used for calculating the Observed Density.
See the TankMaster WinOpi [Reference Manual](#) for more information on inventory calculations. Enter Upper and Lower Density Limits for the Observed Density. Density values outside this range will be notified by TankMaster.
- Enter the P1 Sensor Position, i.e. the position of the center of the Liquid Pressure sensor membrane.
- Enter the Hybrid Min Level.

This value specifies the lowest product level at which TankMaster calculates the Observed Density. Normally, the accuracy of pressure sensors is reduced at low pressures, i.e. at product levels close to the sensor membrane. Therefore, you can specify a limit below which the density calculation is “frozen”. For example, if Hybrid Min Level is equal to 2.0 meter, the Rosemount Tank Gauging system will present a fixed density value for product levels below 2.0 meter.

Note

Specify the actual product level and not the distance between the pressure sensor and the product surface.

9. Enter the P3 Sensor Position, i.e. the position of the center of the Vapor Pressure sensor membrane measured from the tank Zero Level/Datum Plate.
10. Click the **OK** button to save the Hybrid Density configuration.

B.7 Volume configuration

To configure the Rosemount 2410 Tank Hub for volume calculations, choose one of the standard tank shapes, or the strapping table option, see [Table B-4](#). Select None if volume calculation is not used. For the standard tanks, a Volume Offset parameter can be specified to be used for a non-zero volume that corresponds to the Zero Level. This may be useful, for example, if you like to include the product volume below the zero level.

Volume calculation is performed by using a predefined tank shape or a strapping table.

Note

For application software version 1.B5 and older, tank volume calculation has to be enabled in Holding Register 6136.

One of the following standard tank shapes can be chosen:

- Sphere
- Horizontal Cylinder
- Vertical Cylinder
- The following parameters must be entered for a standard tank shape:
 - Tank diameter
 - Tank length (for horizontal cylinder)
 - Volume Offset (use this parameter if you like to include product volume below the zero level)
- For application software version 1.B5 and older, tank volume calculation has to be enabled by setting bit 31 "TANK_VOLUME" in Holding Register 6136

Related information

[Enable volume calculation in a Rosemount 2410 Tank Hub](#)

B.7.1 Strapping table

The Strapping Table option should be used when the tank shape deviates significantly from an ideal sphere or cylinder, or when high volume accuracy is required.

The Strapping Table divides the tank into segments. Level values and corresponding volumes are entered starting at the bottom of the tank. These figures can typically be obtained from tank drawings or from a certificate provided by the tank manufacturer.

A maximum of 100 strapping points can be entered. For each level value the corresponding total volume up to the specified level is entered. The volume value is interpolated if the product surface is between two level values in the table.

B.7.2 Holding and Input registers for volume configuration

Holding registers 4300 to 4732 are used for volume configuration. The different parameters are given in [Table B-4](#).

Table B-4: Holding Registers for Volume Configuration

Name	Holding Register	Description
Volume control	4300	Bit 1: Volume over Zero. By setting this bit presentation of negative volumes for product levels below the Zero level is prevented.
Tank Geometry	4302	0: None 1: Strapping table 2: Sphere 3: Horizontal cylinder 4: Vertical cylinder
Strap table length	4304	Number of strapping table points used
Zero Level To Bottom	4306	Distance from zero level to the tank bottom
L1	4308	Tank diameter
L2	4310	Tank length (for horizontal cylinder)
Interpolation method	4314	0: linear 1: Quadratic
Level offset	4316	Strapping table offset. You can use this function to shift the zero level (empty tank) from the Datum Plate to the bottom of the tank. The Level Offset will be added to the measured level and then used to find the corresponding volume value in the strapping table. A positive Level Offset value will increase the displayed volume.
Volume offset	4318	Strapping table volume offset. Use this function to include product volume below the zero level. This offset will be added to the calculated volume. Note The Volume Offset is added when predefined tank shapes are used as well.
Volume unit	4320	40: Us Gallons 41: Liter 42: UK Gallons 43: Cubic Meter 46: Barrels 112: Cubic Feet
Tank no. (The Rosemount 2410 tank database shows which devices are mapped to the different tanks)	4322	0: not active 1: tank 1 2: tank 2 n: tank n 10: tank 10

Table B-4: Holding Registers for Volume Configuration (continued)

Name	Holding Register	Description
Strap table level 0	4334	Level value for strapping table point no. 0
Strap table volume 0	4336	Volume value for strapping table point no. 0
Strap table level 1	4338	Level value for strapping table point no. 1
Strap table volume 1	4340	Volume value for strapping table point no. 1
Strap table level 99	4730	Level value for strapping table point no. 99
Strap table volume 99	4732	Volume value for strapping table point no. 99

The TankMaster WinSetup program lets you edit Holding registers for volume calculations as illustrated in [Figure B-2](#).

Figure B-2: Holding Register View for Volume Configuration in TankMaster WinSetup

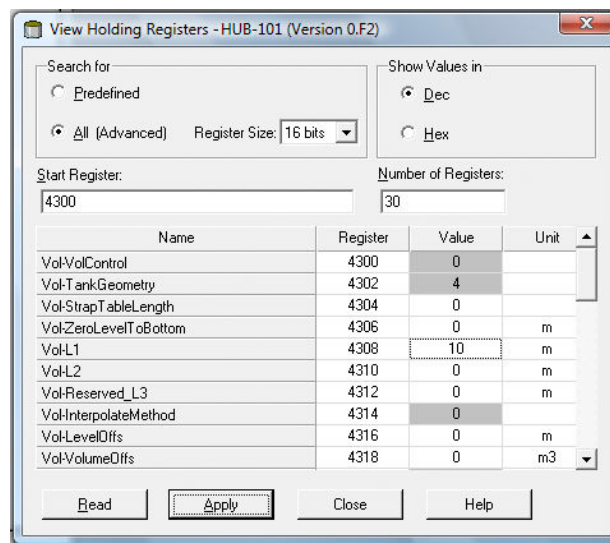

When the Rosemount 2410 is configured for volume calculations the resulting volume values are available in input register area IR3400 to IR3458, IR4700 to IR4710, and IR30000 to IR38000 as illustrated in [Figure B-3](#).

The volume calculation result is available in input register IR4702 as well as in input register area starting with IR3400 (tank 1). The result can be presented in the **View Input Registers** window as illustrated in [Figure B-3](#).

Figure B-3: Input Register View for Volume Read-out in TankMaster WinSetup

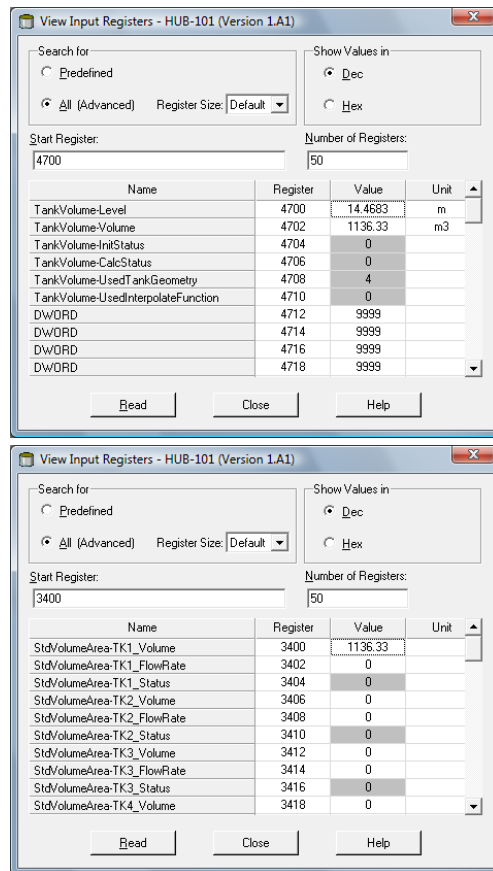

The volume values are also available in input register area starting with IR30000 (IR30148 for tank 1).

Related information

[Viewing input and holding registers using TankMaster](#)

Enable volume calculation in a Rosemount 2410 Tank Hub

For application software version 1.B5 and older, tank volume calculation has to be enabled by setting bit 31 "TANK_VOLUME" in Holding Register 6136.

Procedure

1. In the **TankMaster Winsetup** workspace, right-click the Rosemount 2410 icon.
2. Choose the **View Holding Registers** option.
3. In the **Start Register** box, type 6136, and then click the **Read** button.

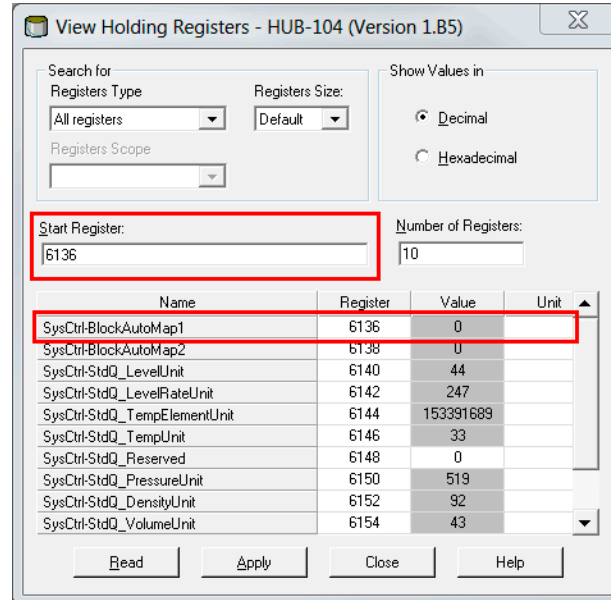

4. For register 6136, double-click the **Value** field.
5. Scroll down to bit 31. If bit 31=0, double-click the Value field to set bit 31=1.

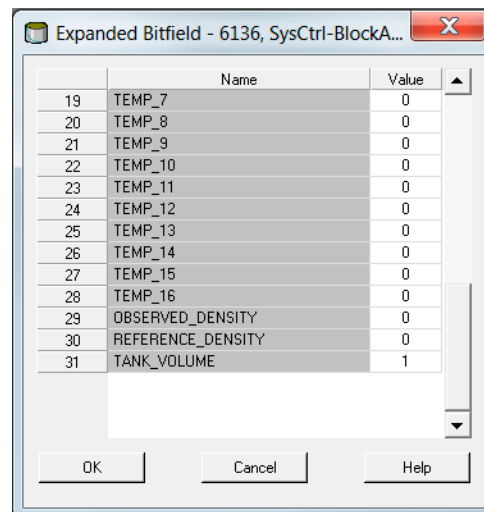

6. Click **OK**.
7. In the **View Holding Registers** window, click the **Apply** button and close the window.

B.8 Arithmetic operations

The Rosemount 2410 Tank Hub supports various arithmetic calculations. Holding Registers 4800 to 4879 are used for up to 10 arithmetic operations. You may perform several operations for multiple tanks.

Arithmetic operations can, for example, be used to calculate the difference between product levels measured by two level gauges.

Table B-5: Rosemount 2410 Holding Registers for Arithmetic Operations

Name	Holding Register no.	Description
Arithmetic1 operation	4800	Arithmetic operation to perform 0: None 1: Subtraction 2: Addition 3: Multiplication 4: Division
Arithmetic1 miscellaneous configuration	4801	Ignore Source Unit
Arithmetic1 TMV type destination	4802	Tank measurement variable in which the result is stored. 56: TMV Delta Level 60: TMV User Defined 1 61: TMV User Defined 2 62: TMV User Defined 3 63: TMV User Defined 4 64: TMV User Defined 5
Arithmetic1 tank number destination	4803	Tank in which the result is stored. 0: Not active 1: Tank 1 2: Tank 2 3: Tank 3 4: Tank 4 5: Tank 5 6: Tank 6 7: Tank 7 8: Tank 8 9: Tank 9 10: Tank 10
Arithmetic1 A TMV Type	4804	Tank measurement variable type for arithmetic operation parameter A
Arithmetic1 A tank number	4805	Tank for the arithmetic operation parameter A. 0: Not active 1: Tank 1 2: Tank 2 3: Tank 3 4: Tank 4 5: Tank 5 6: Tank 6 7: Tank 7 8: Tank 8 9: Tank 9 10: Tank 10
Arithmetic1 B TMV Type	4806	Tank measurement variable type for arithmetic operation parameter B

Table B-5: Rosemount 2410 Holding Registers for Arithmetic Operations (continued)

Name	Holding Register no.	Description
Arithmetic1 B tank number	4807	Tank for the arithmetic operation parameter B. 0: Not active 1: Tank 1 2: Tank 2 3: Tank 3 4: Tank 4 5: Tank 5 6: Tank 6 7: Tank 7 8: Tank 8 9: Tank 9 10: Tank 10
Arithmetic2 operation	4808	
Arithmetic3 operation	4816	
-	-	
Arithmetic10 operation	4872	

See [Delta level calculation](#) for an example on how to set up arithmetic operations.

B.8.1 Delta level calculation

The following example illustrates how to use TankMaster WinSetup to configure a Rosemount 2410 to calculate the difference between product levels for two tanks Tank No. 1 and Tank No. 3. The result is stored in tank measurement variable Delta_Level in Tank 1.

A Virtual Relay Output can be configured to use the measurement variable Delta_Level as source parameter to trigger the relay whenever the level difference exceeds a specified value.

Figure B-4: Arithmetic Operations are Configured in Holding Registers 4800 to 4879

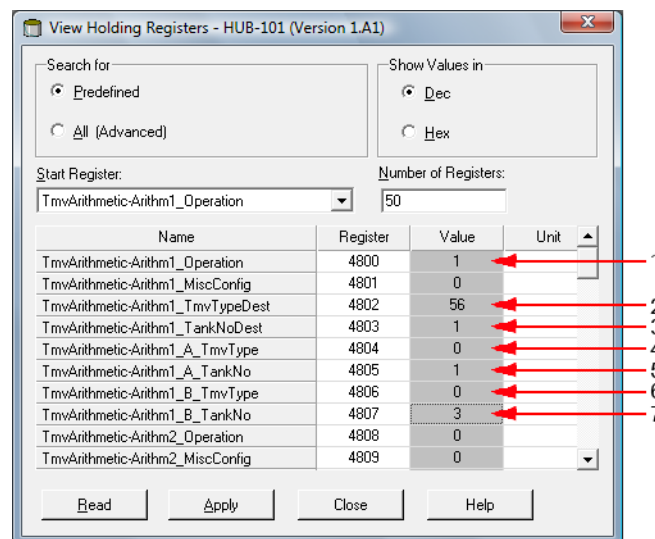

Procedure

1. Choose subtraction.
2. Put the result in Tank Measurement Variable TMV_Delta_Level.
3. Put the result in Tank 1. Now the result will be stored in TMV_Delta_Level for Tank 1.
4. For arithmetic operation parameter A choose Tank Measurement Variable=Level.
5. Choose arithmetic operation parameter A from Tank 1.
6. For arithmetic operation parameter B choose Tank Measurement Variable=Level.
7. Choose arithmetic operation parameter B from Tank 3.

Figure B-5: The Result is Displayed in Input Register 4800 and Higher

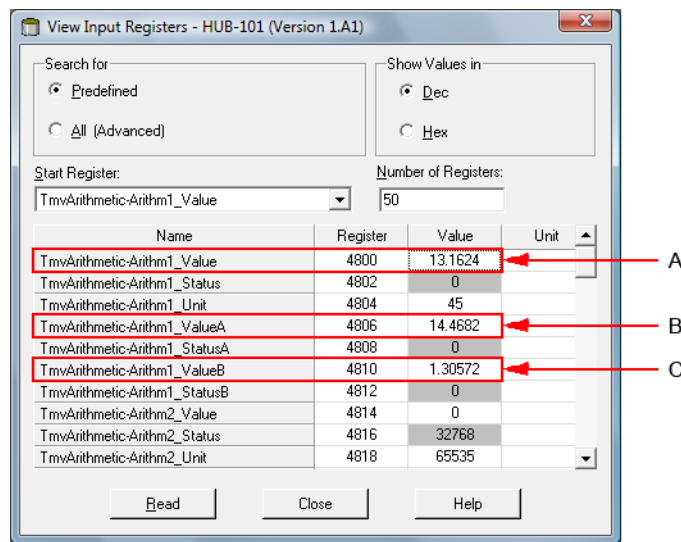

- A. The result is displayed in Input Register 4800.
- B. Parameter A
- C. Parameter B

Related information

[Configure a virtual relay output](#)

B.9 Configure the analog output

To configure the Rosemount 2410 Tank Hub analog output:

Procedure

1. In the **TankMaster Winsetup** workspace, right-click the Rosemount 2410 icon.
2. Choose the **Properties** option.
3. Select the **Configuration** tab.
4. Click the **Analog Output** button to open the **Analog Output Configuration** window.

Note

This button is available if the Analog Output option is activated for the Rosemount 2410 Tank Hub.

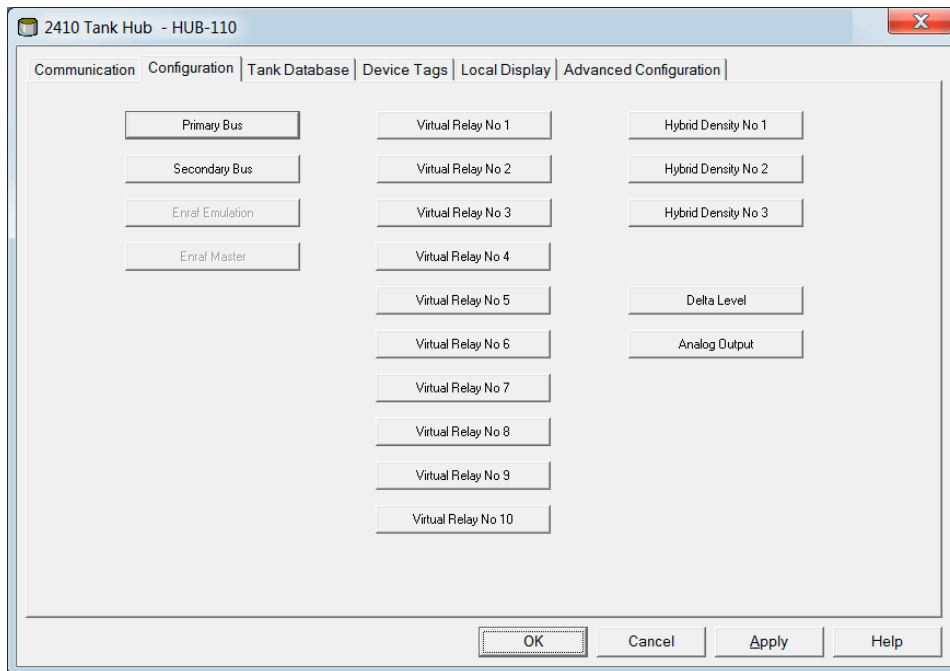

5. Select the **Enable** check box to activate the Analog Output option.

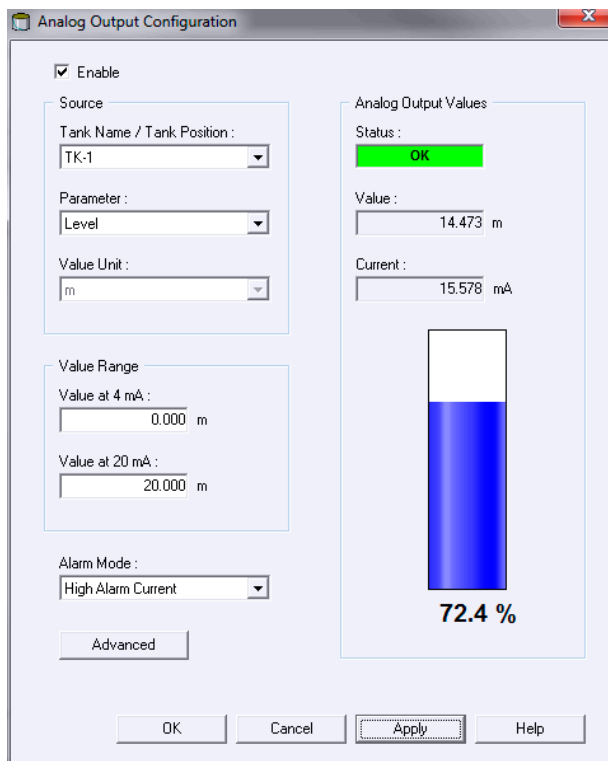

6. In the **Tank Name/Tank Position** list, choose the tank that will provide the desired measurement data source for the Analog Output.

Need help?

If no tank name is configured you can check the tank hub's tank database in case you need to verify that the selected tank position corresponds to the desired tank.

7. Choose the tank parameter and value unit to associate with the 4 - 20 mA Analog Output.
8. Under **Value Range**, set the source values that correspond to the analog output values 4 mA and 20 mA, respectively.
You can specify any value as long as the 20 mA value is above the 4 mA value. Alarm mode is activated in case the measurement value goes out of range.
9. In the **Alarm Mode** list, set the alarm mode as desired.
Alarm mode specifies the analog output state when a measurement error occurs, or when the measurement value is out of range.

Option	Description
High	The output current is set to 21.75 mA (default setting).
Low	The output current is set to 3.75 mA (default setting).
Freeze current	The output current is set to the present value at the time when the error occurs.

10. Optional: Click the **Advanced** button to specify Low/High Alarm Currents and Low/High Saturation Limits.

The output range for the analog output is 3.5 to 23 mA.

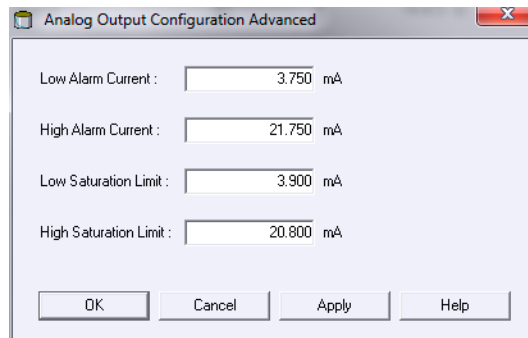

B.9.1 View the current status

The **Analog Output Status** window displays information on the current status.

Procedure

To view the current status information, click the button to the right of the **Status** field. In case an error has occurred the Status field indicates "BAD":

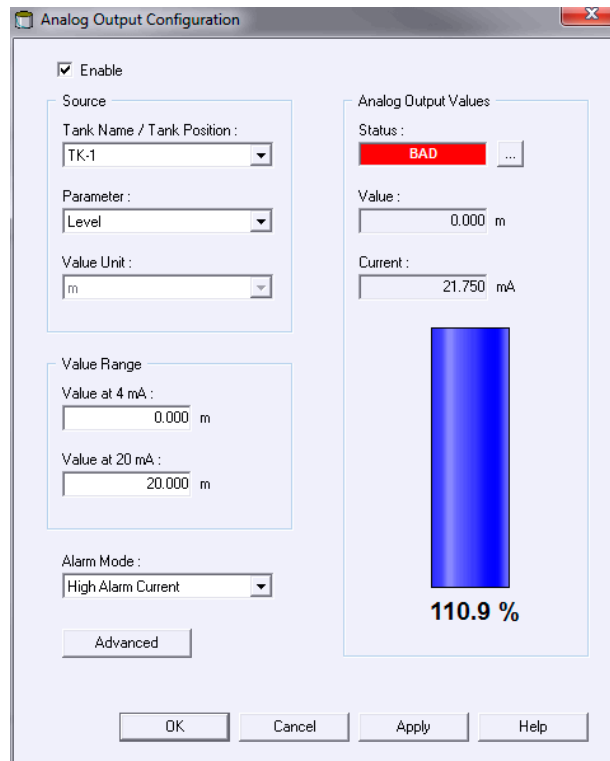

Example

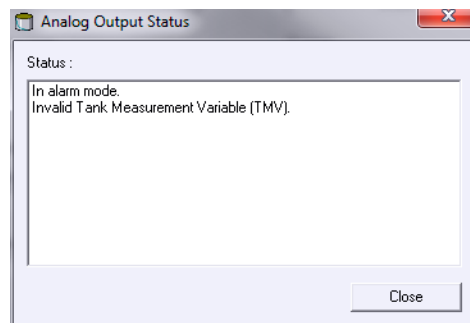

B.10 Configuration of analog input / HART® slave device

B.10.1 Rosemount 2410 Tank Hub analog input

To configure a 4-20 mA device connected to the Rosemount 2410 Tank Hub do the following:

Procedure

1. In the **TankMaster WinSetup** workspace, right-click the Rosemount 2410 Tank Hub icon and choose the **Device Live List** option.
2. In the **2410 Tank Hub Device Live List**, identify the Analog Input device.

The Analog Input appears as Device Type=Analog Input.

Device Type	Device ID	Manufact. ID	Device No	Address	Handled	Connected	Connected via	Configured	Opened	Auto Mode	Tag	
1	2240 MTT	4875	Rosemount	0	232	Yes	Yes	FF	No	No	No	2240-DEVICE-0000004875
2	3051C PT	358854	Rosemount	21	1	Yes	Yes	HART	No	Yes	Yes	
3	5300 GWR	2171724286	Rosemount	0	233	Yes	Yes	FF	No	No	No	2240-DEVICE-0000004875
4	5400 RLT	2171786368	Rosemount	0	240	Yes	Yes	FF	No	No	No	2240-DEVICE-0000004875
5	644 Temp	36200633	Rosemount	0	242	Yes	Yes	FF	No	No	No	2240-DEVICE-0000004875
6	5900 RLG	3442	Rosemount	1	247	Yes	Yes	FF	Yes	Yes	Yes	5900-DEVICE-0000003442
7	Analog Input	1	Unknown	31	0	Yes	Yes	AIN	Yes	Yes	Yes	
8	No Device											
9	No Device											
10	No Device											
11	No Device											
12	No Device											
13	No Device											
14	No Device											
15	No Device											
16	No Device											

- In the **TankMaster WinSetup** workspace, right-click the Rosemount 2410 Tank Hub icon and choose the **Properties** option.
- Select the **Tank Database** tab.
- Associate the Analog Input with a tank in the tank hub's tank database and click the **Apply** button.

Device Type	Device ID	Connected	Connected via	Tank Position	
1	2240 MTT	4875	Yes	FF	Not Configured
2	3051C PT	358854	Yes	HART	Not Configured
3	5300 GWR	2171724286	Yes	FF	Not Configured
4	5400 RLT	2171786368	Yes	FF	Not Configured
5	5900 RLG	3442	Yes	FF	1
6	Analog Input	1	Yes	AIN	1
7	No Device		No		Not Configured
8	644 Temp	36200633	Yes	FF	Not Configured
9	No Device		No		Not Configured
10	No Device		No		Not Configured
11	No Device		No		Not Configured
12	No Device		No		Not Configured
13	No Device		No		Not Configured
14	No Device		No		Not Configured
15	No Device		No		Not Configured
16	No Device		No		Not Configured

Tank Position	Tank Name	Level Modbus Address	ATD Modbus Address
1	TK-1	1	120
2			
3			
4			
5			
6			
7			
8			
9			
10			

Enter tank name with max 10 characters.
The name will be used in field displays
(2410 max 5 characters and 2230 max 10 characters).
The name will also be used as base for the device tags in TankMaster.

Note that it is recommended to install the new devices in TankMaster via "Device Tags" page before closing 2410 configuration !

Need help?

See the Rosemount Tank Gauging [System Configuration Manual](#) for more information on how to configure the tank database.

- Select the **Device Tags** tab and click the **Install New Devices in TankMaster** button. Now the Analog Input will be installed as an ATD in the **TankMaster WinSetup** workspace. Note that although the analog input is actually connected to the Rosemount 2410 Tank Hub, it is handled as an ATD.
- In the **TankMaster WinSetup** workspace, right-click the ATD device icon and choose the **Properties** option.
- Select the **Analog Input** tab.

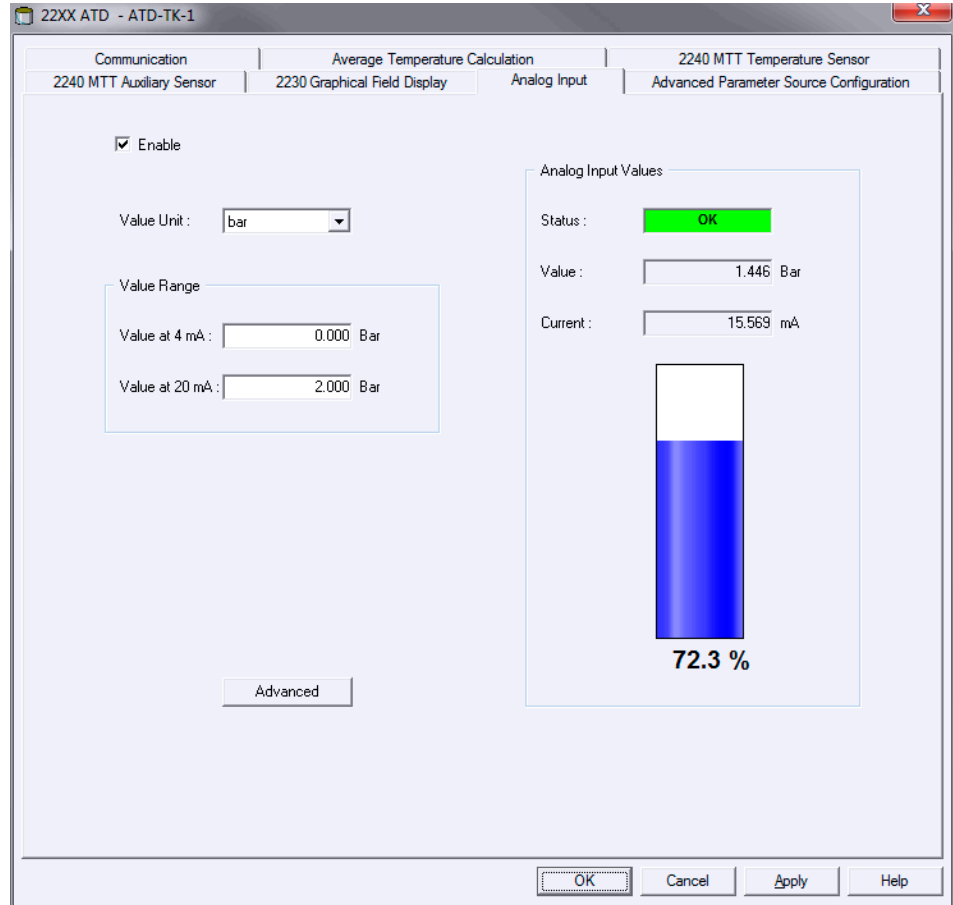

9. Ensure that the **Enable** check box is selected.
10. In the **Value Unit** list, select a suitable unit to match the input source.
11. Under **Value Range**, enter the parameter values that correspond to the analog input values 4 and 20 mA.
You can specify any value as long as the 20 mA value is higher than the 4 mA value. If the measured value goes outside the range values, the analog input enters alarm mode.
12. Optional: Click the **Advanced** button in case you would like to configure Filter Factor and Current Limits.

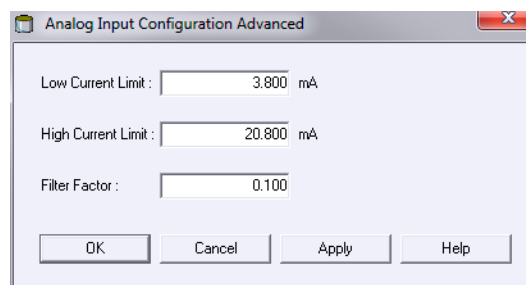

By setting a Filter Factor you can suppress spurious fluctuations in the analog input signal. A value between 0 and 1 can be used. The default value is 0.1. A higher value means less filtering.

The Current Limits define the lower and upper limits of the input currents. Outside this range an error will be indicated. The current limits should correspond to the error limits of connected instruments. If for example an instrument sets the output current in alarm mode to 3.8 mA, you should set the lower error limit to 3.8 or higher.

13. In the **Analog Input Values** pane, verify that Status is OK and that the expected measurement results appear in the Value and Current fields.
14. Select the **Advanced Parameter Source Configuration** tab.
15. Map the Analog Input to the desired tank parameter.

Example

In this example it is mapped to Vapor Pressure.

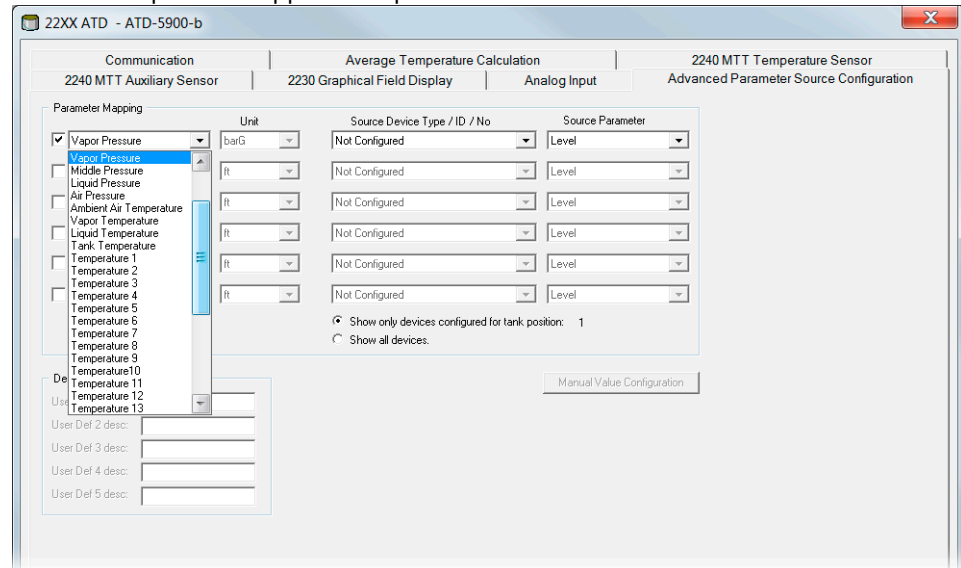

16. In the **Source Device Type / ID / No** list, select **Analog Input** to make sure that the 4 - 20 mA signal of the connected instrument is mapped to the selected parameter.

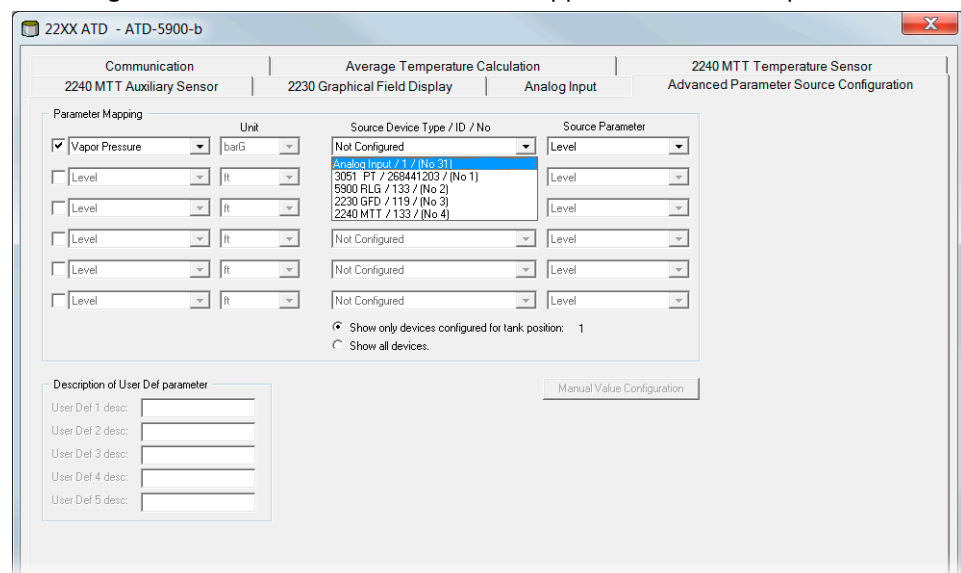

17. In the **Source Parameter** list, select **AIN 1**.

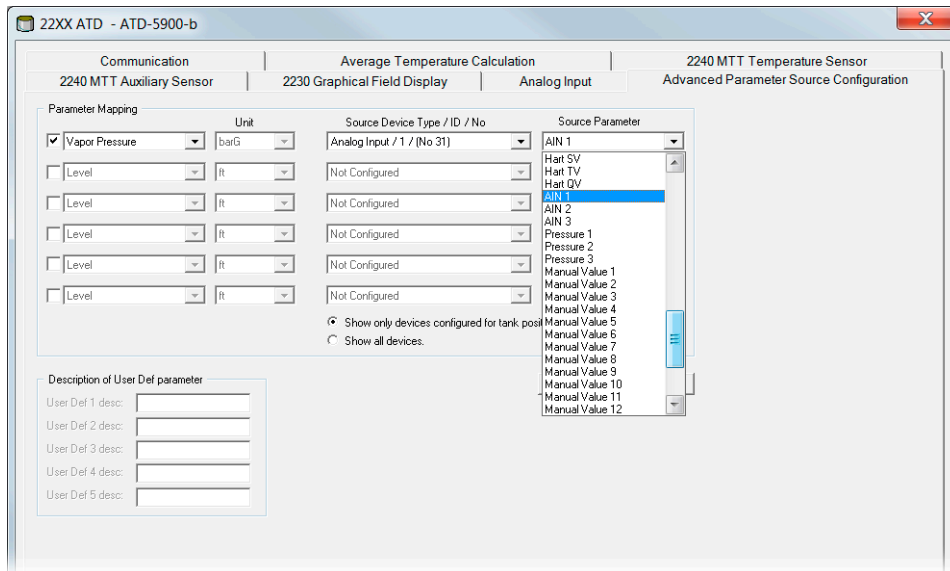

18. In **TankMaster WinSetup**, install and configure the tank that the analog input is associated with in the Rosemount 2410 tank database (see [Step 5](#)).
19. Verify that the tank parameter receives measurement data from the analog input by, for example, opening the **Tank View** window in TankMaster WinOpi.

B.10.2 HART slave configuration

The Rosemount 2410 Tank Hub can act as HART Master for up to three HART slaves in multi-drop configuration. Current mode 4-20 mA is supported in case only one HART device is connected.

Procedure

1. Identify the HART Slave in the Rosemount 2410 Tank Hub **Device Live List**. It will appear as "HART" in the column named "Connected via".
2. Open the Rosemount 2410 tank database and locate the device which will act as a HART Slave.
3. Associate the HART slave with a tank position in the Rosemount 2410 tank database and click the **Apply** button.

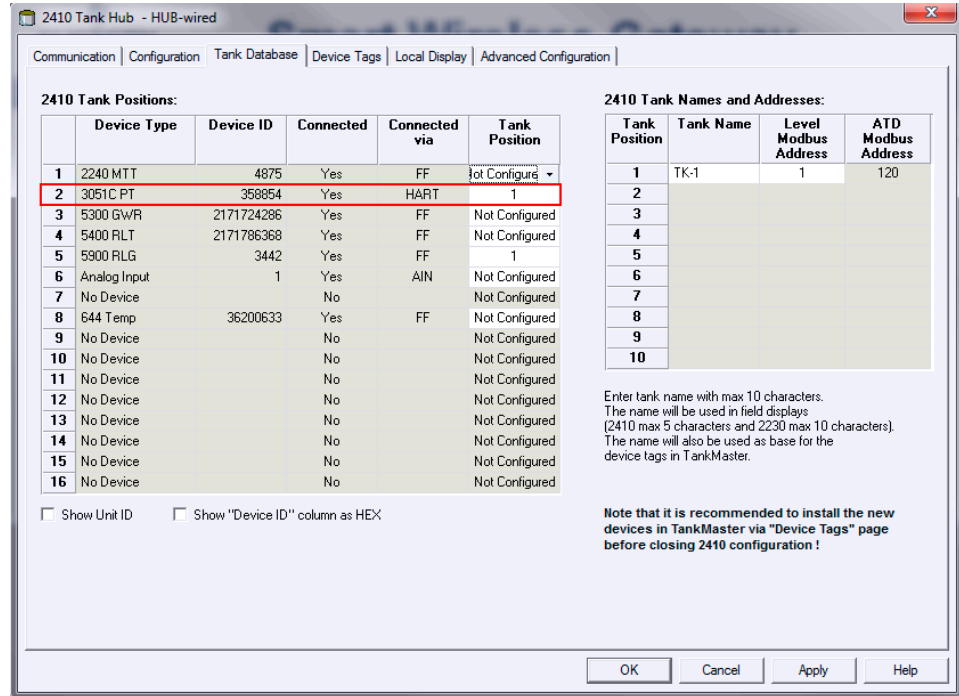

4. Select the **Device Tags** tab and click the **Install New Devices in TankMaster** button. Now the HART Slave device will be installed as an Auxiliary Tank Device (ATD) in the TankMaster WinSetup workspace. Note that although the HART device is actually connected to the Rosemount 2410, it is handled as an ATD in TankMaster.
5. In the **TankMaster WinSetup** workspace, right-click the ATD device icon and choose **Properties**.
6. Select the **Advanced Parameter Source Configuration** tab.
7. Select the desired check box to enable mapping of tank measurement variable to source device and parameter.
8. Choose the desired tank parameter and value unit.

Example

Vapor Pressure is selected in this example.

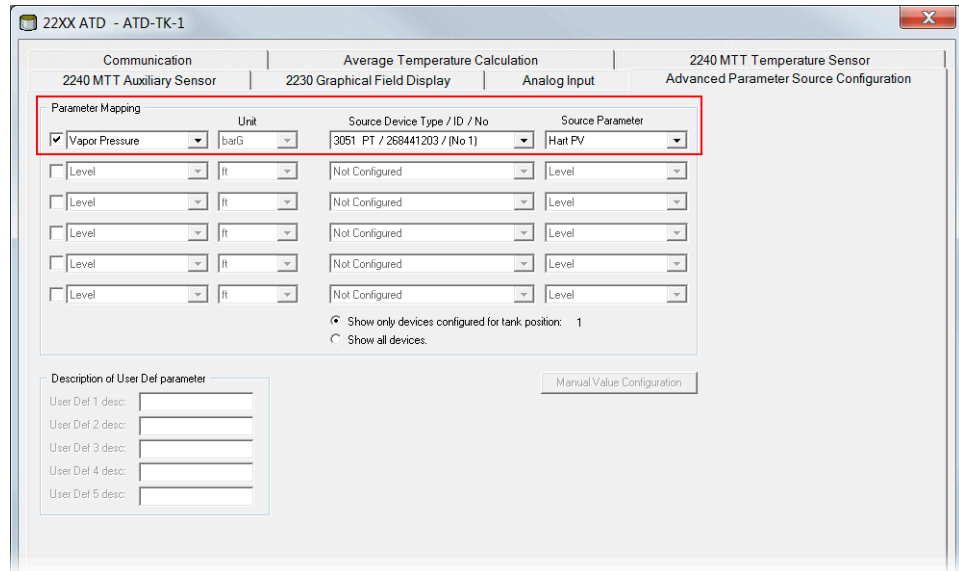

9. In **Source Device Type / ID / No** list, select the appropriate HART device.

Example

In the example above, a 3051 PT is selected.

10. Choose the appropriate source parameter; Hart PV, Hart SV, Hart TV, or Hart QV.
11. In case there are more HART slaves connected, repeat [Step 4](#) to [Step 7](#).
12. In **TankMaster WinSetup**, install and configure the tank that the HART Slave device was associated with in the Rosemount 2410 tank database (see [Step 3](#)).
13. Verify that the tank parameter receives measurement data from the HART Slave by, for example, opening the **Tank View** window in TankMaster WinOpi.

B.10.3 HART slave mapping

In case a Rosemount 2240 Multi-Input Temperature Transmitter is used, some parameters can not be mapped manually to a HART Slave as described in section [HART slave configuration](#). See [Table B-6](#) for a list of parameters that can be mapped.

Table B-6: Possible Parameter Mapping with Rosemount 2410 Tank Hub via FCU 2160

Parameters	Mapping
Free Water Level	X
Vapor Pressure	X
Liquid Pressure	X
Vapor temperature	X ⁽¹⁾
Liquid temperature	X ⁽¹⁾
Temperature 1	X ⁽¹⁾
Temperature 2	X ⁽¹⁾
Temperature 3	X ⁽¹⁾
Temperature 4	X ⁽¹⁾
Temperature 5	X ⁽¹⁾
Temperature 6	X ⁽¹⁾
Temperature 7	X ⁽¹⁾
Temperature 8	X ⁽¹⁾
Temperature 9	X ⁽¹⁾
Temperature 10	X ⁽¹⁾
Temperature 11	X ⁽¹⁾
Temperature 12	X ⁽¹⁾
Temperature 13	X ⁽¹⁾
Temperature 14	X ⁽¹⁾
Delta level	X ⁽²⁾
User defined 1	X

(1) In case no 2240 Temperature Transmitter is mapped

(2) Not available at the same time as User Defined 1

FCU 2160

In case a FCU 2160 is included in the Rosemount Tank Gauging system, make sure that the Slave Database is configured accordingly.

A Rosemount 2410 Tank Hub that includes an analog input and/or a HART slave should be configured as follows:

- Ain=2
- Hin=3

Figure B-6: Configuration of FCU 2160 Slave Database

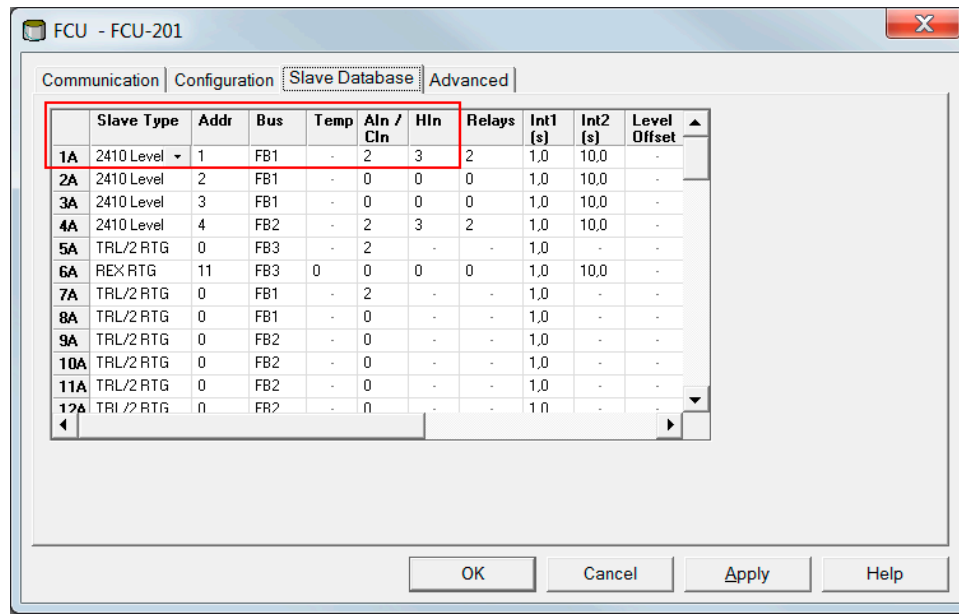

For more information: [Emerson.com/global](https://emerson.com/global)

©2024 Emerson. All rights reserved.

Emerson Terms and Conditions of Sale are available upon request. The Emerson logo is a trademark and service mark of Emerson Electric Co. Rosemount is a mark of one of the Emerson family of companies. All other marks are the property of their respective owners.

ROSEMOUNT™

