

# Rosemount™ 2051 Pressure Transmitter

with HART® Revision 5 and 7 Selectable Protocol



## Safety messages

### **⚠ WARNING**

Read this manual before working with the product. For personal and system safety and for optimum product performance, ensure that you thoroughly understand the contents before installing, using, or maintaining this product.

---

### **⚠ WARNING**

Explosions could result in death or serious injury.

Do not remove the transmitter cover in explosive atmospheres when the circuit is live.

Fully engage both transmitter covers to meet explosion-proof requirements.

Before connecting a handheld communicator in an explosive atmosphere, ensure the instruments in the segment are installed in accordance with intrinsically safe or non-incendive field wiring practices.

Verify the operating atmosphere of the gauge is consistent with the appropriate hazardous locations certifications.

---

### **⚠ WARNING**

Electrical shock could cause death or serious injury.

Avoid contact with the leads and terminals.

---

### **⚠ WARNING**

Process leaks could result in death or serious injury.

Install and tighten all four flange bolts before applying pressure.

Do not attempt to loosen or remove flange bolts while the transmitter is in service.

---

### **⚠ WARNING**

Replacement equipment or spare parts not approved by Emerson for use as spare parts could reduce the pressure retaining capabilities of the transmitter and may render the instrument dangerous.

Use only bolts supplied or sold by Emerson as spare parts.

---

### **⚠ WARNING**

#### **Physical access**

Unauthorized personnel may potentially cause significant damage to and/or misconfiguration of end users' equipment. This could be intentional or unintentional and needs to be protected against.

Physical security is an important part of any security program and fundamental in protecting your system. Restrict physical access by unauthorized personnel to protect end users' assets. This is true for all systems used within the facility.

---

## NOTICE

Improper assembly of manifolds to traditional flange can damage SuperModule™ Platform.

For safe assembly of manifold to traditional flange, bolts must break back plane of flange web (also called bolt hole) but must not contact sensor module housing.

SuperModule and electronics housing must have equivalent approval labeling in order to maintain hazardous location approvals.

When upgrading, verify SuperModule and electronics housing certifications are equivalent. Differences in temperature class ratings may exist, in which case the complete assembly takes the lowest of the individual component temperature classes (for example, a T4/T5 rated electronics housing assembled to a T4 rated SuperModule is a T4 rated transmitter.)

Severe changes in the electrical loop may inhibit HART® communication or the ability to reach alarm values. Therefore, Emerson cannot absolutely warrant or guarantee that the correct failure alarm level (HIGH or LOW) can be read by the host system at the time of annunciation.

## NOTICE

**The products described in this document are NOT designed for nuclear-qualified applications.**

Using non-nuclear qualified products in applications that require nuclear-qualified hardware or products may cause inaccurate readings.

For information on Rosemount nuclear-qualified products, contact [Emerson.com/global](https://www.emerson.com/global).



# Contents

<b>Chapter 1</b>	<b>Introduction.....</b>	<b>7</b>
	1.1 Models covered.....	7
	1.2 HART® installation flowchart.....	8
	1.3 Transmitter overview.....	9
	1.4 Product recycling/disposal.....	10
<b>Chapter 2</b>	<b>Configuration.....</b>	<b>11</b>
	2.1 Overview.....	11
	2.2 System readiness.....	11
	2.3 Configuration basics.....	12
	2.4 Verifying configuration.....	16
	2.5 Basic setup of the transmitter.....	17
	2.6 Configuring the LCD display.....	23
	2.7 Detailed transmitter setup.....	24
	2.8 Performing transmitter tests.....	29
	2.9 Configuring Burst mode.....	31
	2.10 Establishing multidrop communication.....	32
<b>Chapter 3</b>	<b>Hardware installation.....</b>	<b>35</b>
	3.1 Overview.....	35
	3.2 Considerations.....	35
	3.3 Installation procedures.....	36
	3.4 Rosemount 304, 305, and 306 Manifolds.....	50
	3.5 Liquid level measurement.....	66
<b>Chapter 4</b>	<b>Electrical Installation.....</b>	<b>73</b>
	4.1 Overview.....	73
	4.2 Local operator interface (LOI)/LCD display .....	73
	4.3 Configuring security and simulation.....	74
	4.4 Set transmitter alarm.....	77
	4.5 Electrical considerations.....	77
<b>Chapter 5</b>	<b>Operation and maintenance.....</b>	<b>87</b>
	5.1 Overview.....	87
	5.2 Recommended calibration tasks.....	87
	5.3 Calibration overview.....	88
	5.4 Determine calibration frequency.....	90
	5.5 Compensating for span line pressure effects (Range 4 and 5).....	92
	5.6 Trimming the pressure signal.....	93
	5.7 Trimming the analog output.....	96
	5.8 Switching HART® revision.....	99
<b>Chapter 6</b>	<b>Troubleshooting.....</b>	<b>101</b>
	6.1 Overview.....	101
	6.2 Troubleshooting for 4-20 mA output.....	101

6.3	Troubleshooting for 1-5 Vdc output.....	102
6.4	Diagnostic messages.....	104
6.5	Disassembly procedures.....	109
6.6	Reassembly procedures.....	111
<b>Chapter 7</b>	<b>Safety Instrumented Systems (SIS) requirements.....</b>	<b>115</b>
7.1	Identify safety certified transmitters.....	115
7.2	Installation in Safety Instrumented Systems (SIS) applications.....	115
7.3	Configuring in Safety Instrumented Systems (SIS) applications.....	116
7.4	Safety Instrumented System (SIS) operation and maintenance.....	117
7.5	Inspection.....	119
<b>Appendix A</b>	<b>Reference data.....</b>	<b>121</b>
A.1	Product certifications.....	121
A.2	Ordering information, specifications, and drawings.....	121
<b>Appendix B</b>	<b>Communication device menu trees and fast keys.....</b>	<b>123</b>
B.1	Communication device menu trees.....	123
B.2	Communication device fast keys.....	127
<b>Appendix C</b>	<b>Local operator interface (LOI) menu.....</b>	<b>129</b>
C.1	Local operator interface (LOI) menu tree.....	129
C.2	Local operator interface (LOI) menu tree - <b>EXTENDED MENU</b> .....	130
C.3	Enter numbers.....	131
C.4	Text entry.....	132

# 1 Introduction

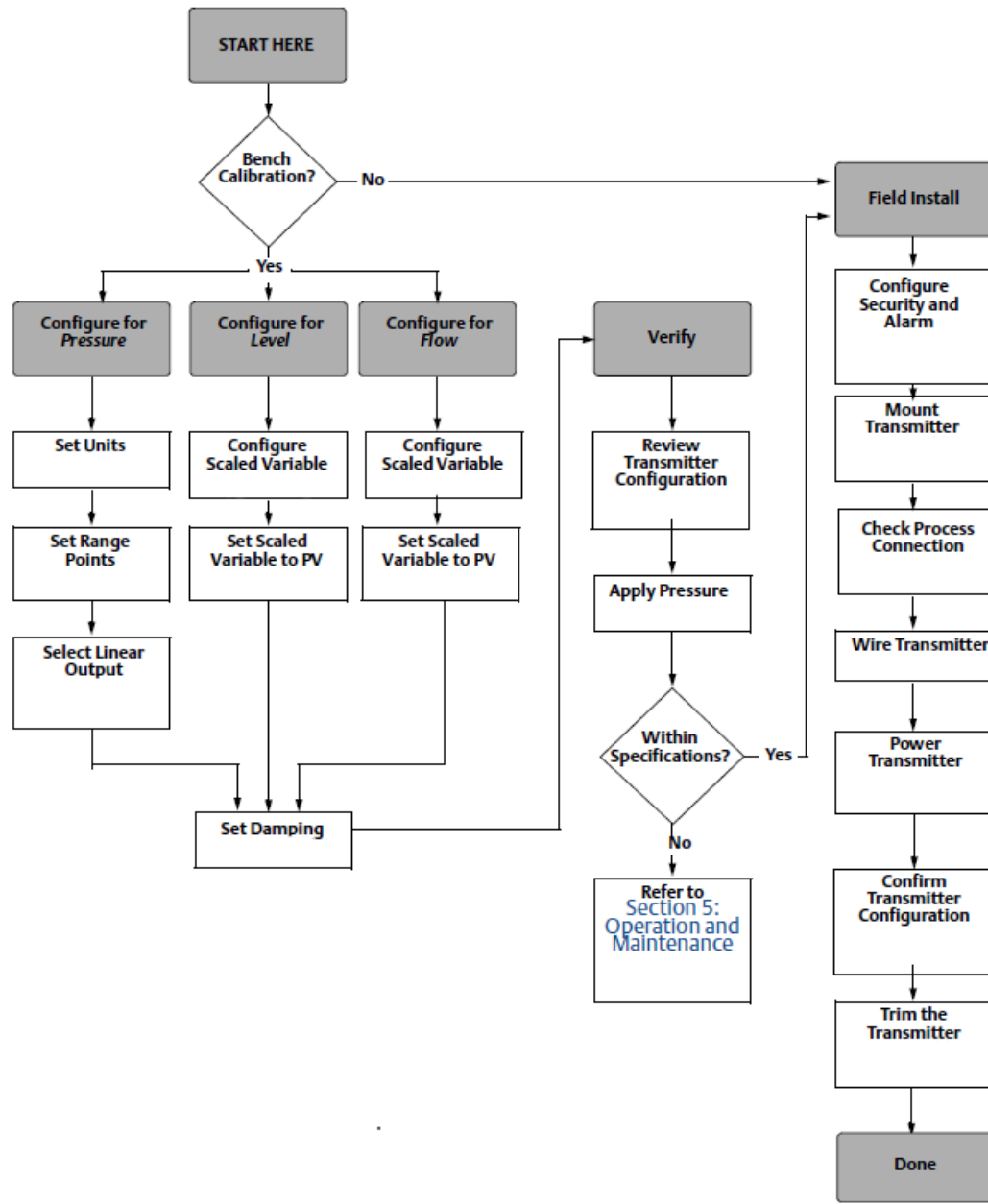
## 1.1 Models covered

The following Rosemount 2051 Transmitters are covered by this manual:

- 2051C Coplanar™ Pressure Transmitter
- 2051T In-Line Pressure Transmitter
  - Measures gauge/absolute pressure up to 10,000 psi (689.5 bar).
- 2051L Level Transmitter
  - Measures level and specific gravity up to 300 psi (20.7 bar).
- 2051CF Series Flow Meter
  - Measures flow in line sizes from ½-in. (15 mm) to 96 in. (2400 mm).

## 1.2 HART® installation flowchart

Figure 1-1: HART installation flowchart





## 1.3 Transmitter overview

The Rosemount 2051C Coplanar™ design is offered for differential pressure (DP) and gauge pressure (GP) measurements.

The 2051C uses capacitance sensor technology for DP and GP measurements. The Rosemount 2051T uses piezoresistive sensor technology for absolute pressure (AP) and GP measurements.

The major components of the transmitter are the sensor module and the electronics housing. The sensor module contains the oil-filled sensor system (isolating diaphragm, oil fill system, and sensor) and the sensor electronics. The sensor electronics are installed within the sensor module and include a temperature sensor, a memory module, and the analog-to-digital signal converter (A/D converter). The electrical signals from the sensor module are transmitted to the output electronics in the electronics housing. The electronics housing contains the output electronics board, the optional external configuration buttons, and the terminal block. The basic block diagram of the transmitter is illustrated in [Figure 1-3](#).

When pressure is applied to the isolating diaphragm, the oil deflects the sensor which then changes its voltage signal. This signal is then changed to a digital signal by the signal processing. The microprocessor then takes the signals from the signal processing and calculates the correct output of the transmitter. This signal is then sent to the digital-to-analog D/A converter, which converts the signal back to the analog signal, and then superimposes the HART® signal on the 4–20 mA or 1-5 Vdc output.

You can order an optional LCD display that connects directly to the interface board which maintains direct access to the signal terminals. The display indicates output and abbreviated diagnostic messages. Emerson provides a glass display cover. For 4-20 mA HART output, the LCD display features a two-line display. The first line displays the actual measured value, and the second line of six characters displays the engineering units. The LCD display can also display diagnostic messages.

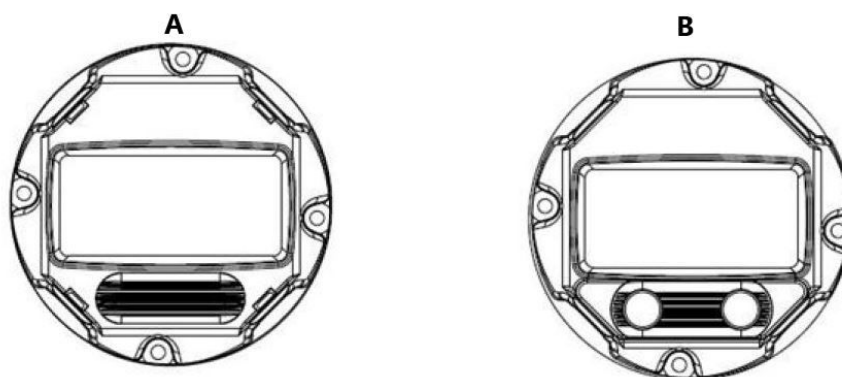
---

### Note

The LCD display uses a 5 × 6 character display and can display output and diagnostic messages. The local operator interface (LOI) display uses an 8 × 6 character display and can display output, diagnostic messages, and LOI menu screens. The LOI display comes with two buttons mounted on the front of the display board. See [Figure 1-2](#).

---

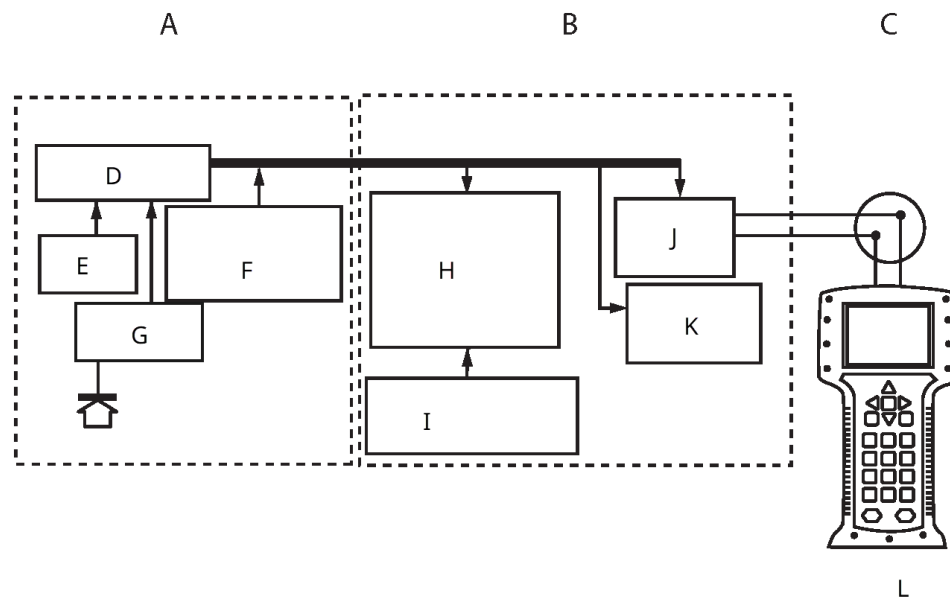
**Figure 1-2: LCD/LOI display**



A. LCD display  
B. LOI display

---

Figure 1-3: Block diagram of operation



- A. Sensor module
- B. Electronics board
- C. 4-20 mA signal to control system
- D. Signal processing
- E. Temperature sensor
- F. Sensor module memory
- G. Pressure sensor
- H. Microprocessor
  - Sensor linearization
  - Rerange
  - Damping
  - Diagnostics
  - Engineering units
  - Communication
- I. Memory
  - Configuration
- J. Digital-to-analog signal conversion
- K. Digital communication
- L. Communication device

## 1.4 Product recycling/disposal

Consider recycling equipment and packaging and dispose of them in accordance with local and national legislation/regulations.

## 2 Configuration

### 2.1 Overview

This section contains information on commissioning and tasks that should be performed on the bench prior to installation, as well as tasks performed after installation.

This section provides communication device, AMS Device Manager, and local operator interface (LOI) instructions to perform configuration functions. For convenience, communication device fast key sequences are labeled “fast keys,” and abbreviated LOI menus are provided for each function below.

#### Related information

[Performing transmitter tests](#)

[Communication device menu trees](#)

[Local operator interface \(LOI\) menu tree](#)

### 2.2 System readiness

- If using HART<sup>®</sup>-based control or AMS, confirm the HART capability of such systems prior to commissioning and installation. Not all systems are capable of communicating with HART Revision 7 devices.
- For instructions on how to change the HART revision of your transmitter, see [Switching HART<sup>®</sup> revision](#).

#### 2.2.1 Confirm correct device descriptor

##### Procedure

1. Verify the latest device descriptor (DD/DTM™) is loaded on your systems to ensure proper communications.
2. Reference [Software & Drivers](#) or [FieldCommGroup.org](#) for the latest DD.
3. Click **Device Driver**.
4. In the **Choose a Software Type** drop-down list, select DD - Device Descriptor.
5. In the **Choose a Communication Protocol** drop-down list, select HART.
6. In the **Choose a Brand** drop-down list, select Rosemount.
7. Select the desired DD (listed by product name and HART<sup>®</sup> revision).
8. Select the **SOFTWARE VERSION, HOST SYSTEM, and DEVICE MANAGER**.
9. Click **DOWNLOAD**.

### Example

**Table 2-1: Rosemount 2051 device revisions and files**

Software release date	Identify device		Find DD		Review instructions	Review functionality
	NAMUR software revision <sup>(1)</sup>	HART software revision <sup>(2)</sup>	HART universal revision	Device revision <sup>(3)</sup>	Reference manual	Changes to software
August 2012	1.0.0	01	7	10	<a href="#">Rosemount 2051 Reference Manual</a>	<sup>(4)</sup>
			5	9		
January 1998	N/A	178	5	3	<a href="#">Rosemount 2051 Reference Manual</a>	N/A

- <sup>(1)</sup> NAMUR software revision is located on the hardware tag of the device
- <sup>(2)</sup> Use a HART-capable configuration tool to find the HART software revision.
- <sup>(3)</sup> Device descriptor file names use Device and DD Revision, such as 10\_01. HART protocol is designed to enable legacy device descriptor revisions to continue to communicate with new HART devices. To access new functionality, download the new DD. Emerson recommends downloading new DD files to ensure full functionality.
- <sup>(4)</sup> HART Revision 5 and 7 selectable, safety certified, local operator interface (LOI), scaled variable, configurable alarms, expanded engineering units.

## 2.3 Configuration basics

### NOTICE

Set all transmitter hardware adjustments during commissioning to avoid exposing the transmitter electronics to the plant environment after installation.

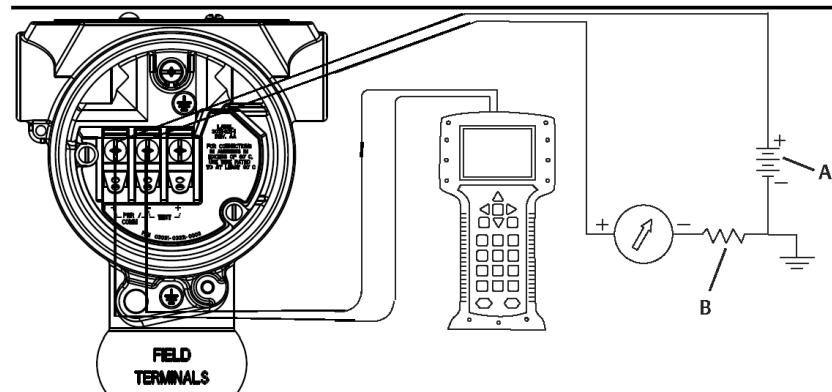
You can configure the transmitter either before or after installation. Configuring the transmitter on the bench using either a communication device, AMS Device Manager, or local operator interface LOI ensures all transmitter components are in working order prior to installation. Verify that the security switch is set in the unlock (🔓) position in order to proceed with configuration.

### 2.3.1 Configuring on the bench

To configure on the bench, required equipment includes a power supply and a communication device, AMS Device Manager, or a local operator interface (LOI) (option M4).

Wire equipment as shown in [Figure 2-1](#). To ensure successful HART® communication, a resistance of at least 250 Ωs must be present between the transmitter and the power supply. Connect the communication device leads to the terminals labeled COMM on the terminal block or 1-5 V configuration, wire as shown in [Figure 2-1](#). Connect the communication device to the terminals labeled VOUT/COMM.

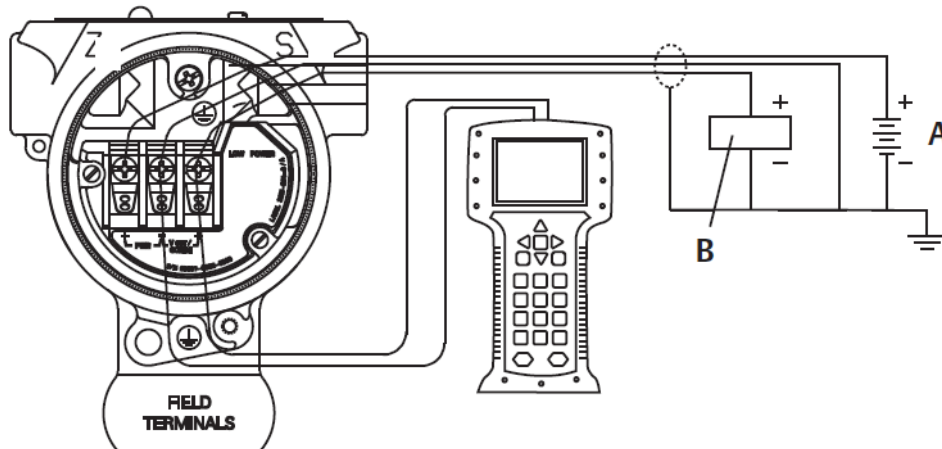
Figure 2-1: Wiring the transmitter (4–20 mA HART)



- A. Vdc supply
- B.  $R_L \geq 250$  (necessary for HART communication only)

## 2.3.2 Configuration tools

Figure 2-2: Wiring the transmitter (1–5 Vdc low power)



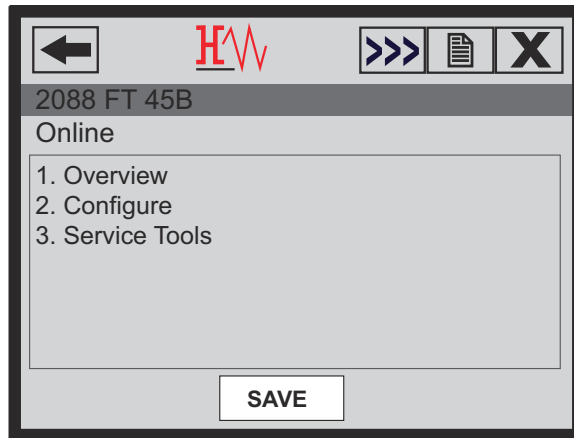
- A. DC power supply
- B. Voltmeter

## Configuring with a communication device

There are two interfaces available with the communication device: Traditional and Dashboard interfaces. This section describes all steps using a communication device using Dashboard interfaces.

Figure 2-3 shows the Device Dashboard interface. It is critical that the latest device descriptors (DDs) are loaded into the communication device. Refer to either [Software & Drivers](#) or [FieldCommGroup.org](#) to download latest DD library.

**Figure 2-3: Device Dashboard**



#### Related information

[System readiness](#)

[Communication device menu trees](#)

### Configuring with AMS Device Manager

Full configuration capability with AMS Device Manager requires loading the most current device descriptor (DD) for this device.

Download the latest DD at [Software & Drivers](#) or [FieldCommGroup.org](#).

#### Note

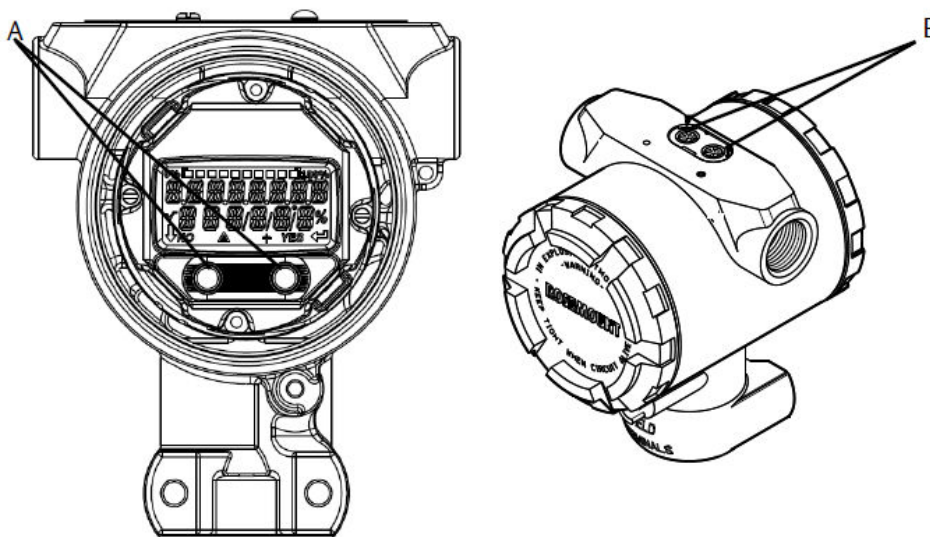
This document describes all steps using AMS Device Manager using version 11.5.

### Configuring with a local operator interface (LOI)

Use option code M4 to order a transmitter with an LOI.

To activate the LOI, push either configuration button. Configuration buttons are located on the LCD display (must remove housing cover to access), or underneath the top tag of the transmitter. See [Table 2-2](#) for configuration button functionality and [Figure 2-4](#) for configuration button location. When using the LOI for configuration, several features require multiple screens for a successful configuration. Data entered will be saved on a screen-by-screen basis; the LOI will indicate this by flashing *SAVED* on the LCD display each time.

Figure 2-4: LOI configuration buttons



- A. Internal configuration buttons
- B. External configuration buttons

Table 2-2: LOI button operation

Button		
Left	No	SCROLL
Right	Yes	ENTER

**Related information**

[Local operator interface \(LOI\) menu tree](#)

### 2.3.3 Setting the loop to manual

Whenever sending or requesting data that would disrupt the loop or change the output of the transmitter, set the process application loop to **manual** control.

The communication device, AMS Device Manager, or the local operator interface (LOI) will prompt you to set the loop to manual when necessary. The prompt is only a reminder; acknowledging this prompt does not set the loop to manual. It is necessary to set the loop to manual control as a separate operation.

## 2.4 Verifying configuration

Emerson recommends verifying various configuration parameters prior to installation into the process.

This section details the various parameters for each configuration tool. Depending on what configuration tool(s) are available, follow the steps listed.

### 2.4.1 Verify configuration using a communication device

Review configuration parameters listed in [Table 2-3](#) prior to transmitter installation.

Fast key sequences for the latest device descriptors (DDs) are shown in [Table 2-3](#). For fast key sequences for legacy DDs, contact your local Emerson Representative.

#### Table 2-3: Device Dashboard fast key sequence

From the **HOME** screen, enter the fast key sequences listed:

Function	Fast key sequence
Alarm and Saturation Levels	2, 2, 2, 5
Damping	2, 2, 1, 1, 5
Primary Variable	2, 1, 1, 4, 1
Range Values	2, 1, 1, 4
Tag	2, 2, 7, 1, 1
Transfer Function	2, 2, 1, 1, 6
Units	2, 2, 1, 1, 4

### 2.4.2 Verify configuration using AMS Device Manager

#### Procedure

1. Right-click the device and select **Configuration Properties** from the menu.
2. Navigate the tabs to review the transmitter configuration data.

### 2.4.3 Verify configuration using a local operator interface (LOI)

#### Procedure

1. Press any configuration button to activate the LOI.
2. Select **VIEW CONFIG** to review the following parameters:
  - Tag
  - Units
  - Transfer function
  - Alarm and saturation levels
  - Primary variable
  - Range values
  - Damping
3. Use the configuration buttons to navigate through the menu.



## 2.4.4 Verifying process variables configuration

This section describes how to verify that the correct process variables are selected.

### Verify process variables using a communication device

#### Procedure

On the **HOME** screen, enter the fast key sequence: 3, 2, 1.

### Verify process variables using AMS Device Manager

Complete the following steps to verify process variables with AMS Device Manager.

#### Procedure

1. Right-click the device and select **Overview** from the menu.
2. Select **All Variables** to display the primary, secondary, tertiary, and quaternary variables.

## 2.5 Basic setup of the transmitter

This section goes through the necessary steps for basic setup of a pressure transmitter.

#### Related information

[Configuring scaled variable](#)

### 2.5.1 Setting pressure units

The Pressure Unit variable sets the unit of measure for the reported pressure.

#### Set pressure units using a communication device

##### Procedure

From the **HOME** screen, enter the fast key sequence: 2, 2, 1, 1, 4.

#### Set pressure units using AMS Device Manager

##### Procedure

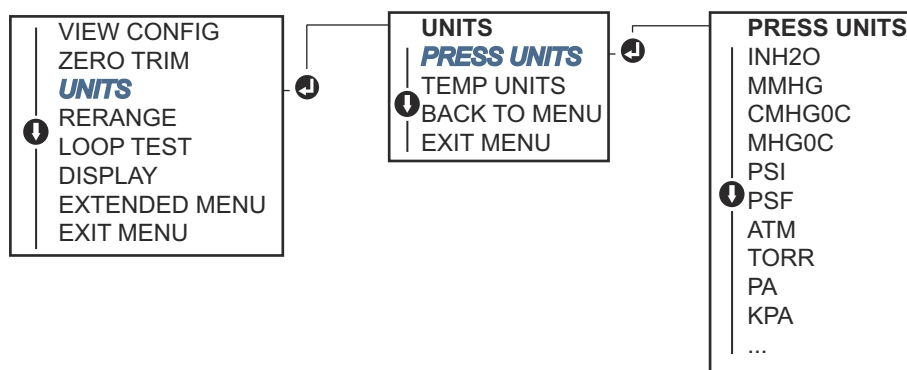
1. Right-click the device and select **Configure**.
2. Select **Manual Setup** and select desired units from the **Pressure Units** drop-down menu.
3. Select **Send** when complete.

## Set pressure units using the local operator interface (LOI)

### Procedure

1. Follow [Figure 2-5](#) to select desired pressure and temperature units. Go to **UNITS** → **PRESS UNITS**.

**Figure 2-5: Selecting pressure units with LOI**



2. Use the **SCROLL** and **ENTER** buttons to select the desired unit.
3. Save by selecting **SAVE** as indicated on the LCD display screen.

## 2.5.2

### Setting transmitter output (transfer function)

The Rosemount 2051 Transmitter has two transfer functions for pressure applications: **Linear** and **Square Root**.

As shown in [Figure 2-7](#), activating the **Square Root** option makes the transmitter analog output proportional to flow.

However, for differential pressure (DP) flow and DP level applications, Emerson recommends using **Scaled Variable**.

#### Related information

[Configuring scaled variable](#)

### Set transmitter output using a communication device

#### Procedure

From the **HOME** screen, enter the fast key sequence: 2, 2, 1, 1, 6.

### Set transmitter output using AMS Device Manager

#### Procedure

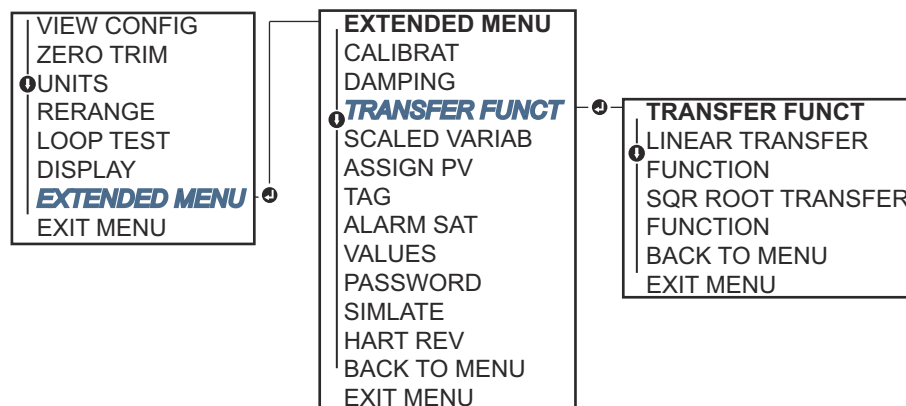
1. Right-click the device and select **Configure**.
2. Select **Manual Setup**, select output type from **Analog Output Transfer Function**, and click **Send**.
3. Carefully read the warning and select **Yes** if it is safe to apply the changes.

## Set transmitter output using the local operator interface (LOI)

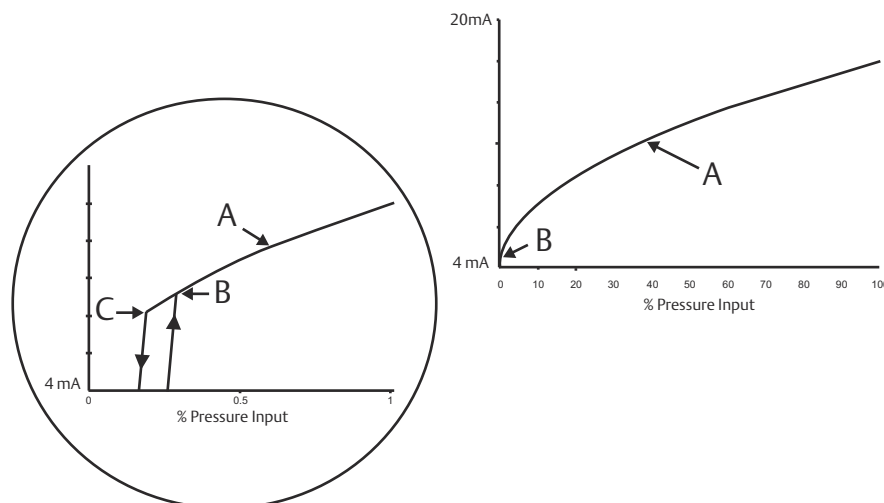
Reference [Figure 2-6](#) to select either linear or square root transfer function using the LOI.

Go to **EXTENDED MENU** → **TRANSFER FUNCT.**

**Figure 2-6: Set transmitter output with LOI**



**Figure 2-7: 4-20 mA HART® square root output transition point**



- A. Square root curve
- B. 5 percent transition point
- C. 4 percent transition point

### 2.5.3 Reranging the transmitter

The range values command sets each of the lower and upper range analog values (4 and 20 mA/1–5 Vdc points) to a pressure.

The lower range point represents 0 percent of range, and the upper range point represents 100 percent of range. In practice, the transmitter range values may be changed as often as necessary to reflect changing process requirements.

Select from one of the methods below to rerange the transmitter. Each method is unique; examine all options closely before deciding which method works best for your process.

- Rerange by manually setting range points with a communication device, AMS Device Manager, or local operator interface (LOI).
- Rerange with a pressure input source and a communication device, AMS Device Manager, LOI, or local **Zero** and **Span** buttons.

## Manually rerange the transmitter by entering range points

### Enter range points using a communication device

#### Procedure

From the **HOME** screen, enter the fast key sequence: 2, 2, 2, 1.

### Enter range points using AMS Device Manager

#### Procedure

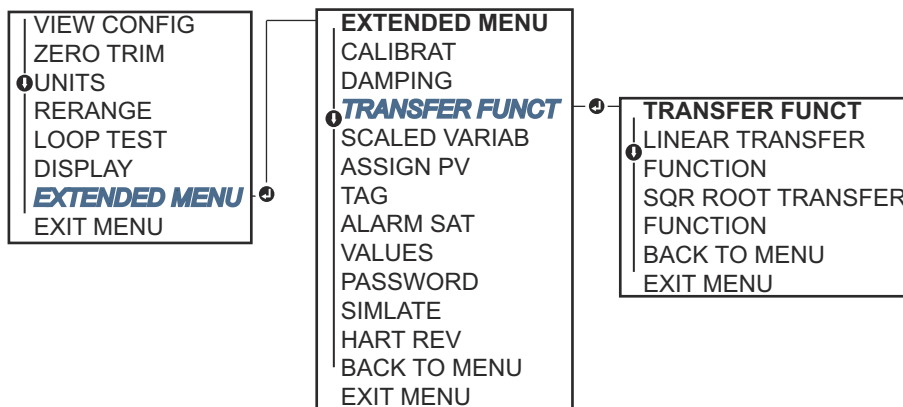
1. Right-click the device and select **Configure**.
2. Go to **Manual Setup** → **Analog Output**.
3. Enter upper and lower range values in the **Range Limits** box and select **Send**.
4. Carefully read the warning and select **Yes** if it is safe to apply the changes.

### Enter range points using a local operator interface (LOI)

#### Procedure

See [Figure 2-8](#) to rerange the transmitter using the LOI. Enter values using the **SCROLL** and **ENTER** buttons.

Figure 2-8: Rerange using LOI



## Reranging the transmitter with applied pressure source

Reranging using an applied pressure source is a way of reranging the transmitter without entering specific 4 and 20 mA (1–5 Vdc) points.

### Rerange with an applied pressure source using a communication device

#### Procedure

From the **HOME** screen, enter the fast key sequence:

**Fast keys**            2, 2, 2, 2

## Rerange with an applied pressure source using AMS Device Manager

### Procedure

1. Right-click the device and select **Configure**.
2. Select the **Analog Output** tab.
3. Click **Range by Applying Pressure** and follow the screen prompts to range the transmitter.

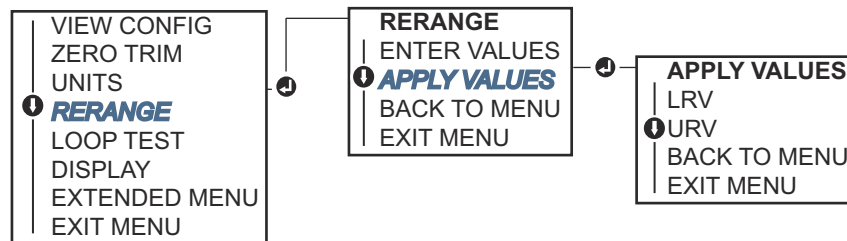
## Rerange with an applied pressure source using the local operator interface (LOI)

### Procedure

Go to **RERANGE** → **APPLY VALUES**.

See

Figure 2-9: Rerange with an applied pressure source using LOI

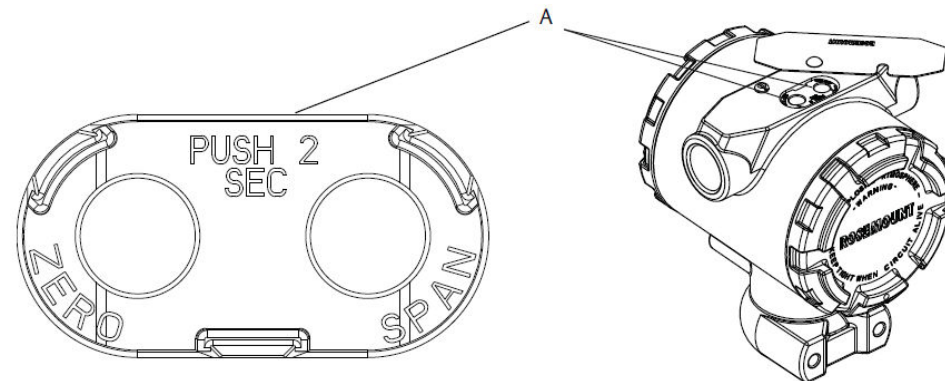


## Rerange with an applied pressure source using local Zero and Span buttons

If you ordered the transmitter with option code D4, you can use the local **Zero** and **Span** buttons to rerange the transmitter with an applied pressure.

Refer to [Figure 2-10](#) for analog **Zero** and **Span** button location.

Figure 2-10: Analog Zero and Span buttons



A. **Zero** and **Span** buttons

### Procedure

1. Loosen the screw holding the top tag of the transmitter housing. Rotate the label to expose the **Zero** and **Span** buttons.

2. Confirm device has local **Zero** and **Span** buttons by verifying blue retainer under the tag.
3. Apply transmitter pressure.
4. Rerange the transmitter.
  - To change the zero (4 mA/1 V point) while maintaining the span: Press and hold **Zero** button for at least two seconds and then release.
  - To change the span (20 mA/5 V point) while maintaining the zero point: Press and hold the **Span** button for at least two seconds and then release.

---

**Note**

4 mA and 20 mA points must maintain the minimum span.

---

**Note**

- If the transmitter security is on, you will not be able to adjust the zero or span points.
  - The span is maintained when the 4 mA/1 V point is set. The span changes when the 20 mA 5 V point is set. If the lower range point is set to a value that causes the upper range point to exceed the sensor limit, the upper range point is automatically set to the sensor limit, and the span is adjusted accordingly.
  - Regardless of the range points, the transmitter measure and report all readings within the digital limits of the sensor. For example, if the 4 and 20 mA (1–5 Vdc) points are set to 0 and 10 inH<sub>2</sub>O, and the transmitter detects a pressure of 25 inH<sub>2</sub>O, it digitally outputs the 25 inH<sub>2</sub>O reading and a 250 percent of range reading.
- 

## 2.5.4

### Damping

The **Damping** command changes the response time of the transmitter; higher values can smooth variations in output readings caused by rapid input changes.

Determine the appropriate **Damping** setting based on the necessary response time, signal stability, and other requirements of the loop dynamics within your system. The **Damping** command uses floating point configuration, allowing you to input any damping value within 0 - 60 seconds.

### Damping using a communication device

#### Procedure

1. From the **HOME** screen, enter the fast key sequence: 2, 2, 1, 1, 5.
2. Enter desired **Damping** value and select **APPLY**.

### Damping using AMS Device Manager

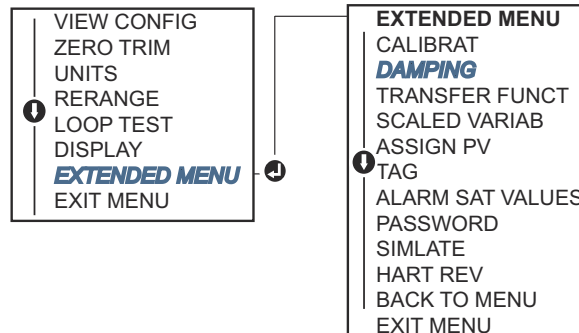
#### Procedure

1. Right-click the device and select **Configure**.
2. Select **Manual Setup**.
3. Within the **Pressure Setup** box, enter desired damping value and click **Send**.
4. Carefully click the warning and click **Yes** if it is safe to apply the changes.

## Damping using a local operator interface (LOI)

Reference [Figure 2-11](#) to enter damping values using an LOI.

**Figure 2-11: Damping using LOI**



## 2.6 Configuring the LCD display

The LCD display configuration command allows customization of the LCD display to suit application requirements. The LCD display will alternate between the selected items.

- **Pressure Units**
- **% of Range**
- **Scaled Variable**
- **Sensor Temperature**
- **mA/Vdc Output**

You can also configure the LCD display to display configuration information during the device startup. Select *Review Parameters* at start-up to enable or disable this functionality.

### Related information

[Configure LCD display with a local operator interface \(LOI\)](#)

### 2.6.1 Configure LCD display using a communication device

#### Procedure

From the **HOME** screen, enter the fast key sequence: 2, 2, 4.

### 2.6.2 Configure LCD display using AMS Device Manager

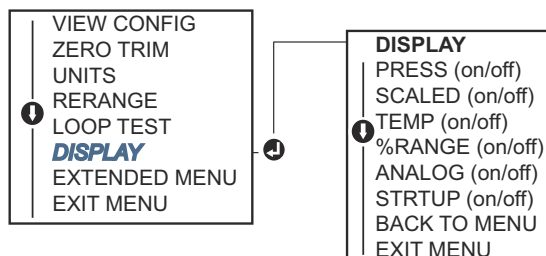
#### Procedure

1. Right-click the device and select **Configure**.
2. Click **Manual Setup** and select the **Display** tab.
3. Select desired display options and select **Send**.

## 2.6.3 Configure LCD display with a local operator interface (LOI)

Refer to [Figure 2-12](#) for LCD display configuration using an LOI.

**Figure 2-12: Display with LOI**



## 2.7 Detailed transmitter setup

### 2.7.1 Configuring alarm and saturation levels

In normal operation, the transmitter will drive the output in response to pressure from the lower to upper saturation points. If the pressure goes outside the sensor limits, or if the output would be beyond the saturation points, the output will be limited to the associated saturation point.

The transmitter automatically and continuously performs self-diagnostic routines. If the self-diagnostic routines detect a failure, the transmitter drives the output to configured alarm and value based on the position of the alarm switch.

**Table 2-4: Rosemount alarm and saturation values**

Level	4–20 mA (1–5 Vdc) saturation	4–20 mA (1–5 Vdc) alarm
Low	3.90 mA (0.97 V)	≤ 3.75 mA (0.95 V)
High	20.80 mA (5.20 V)	≥ 21.75 mA (5.40 V)

**Table 2-5: NAMUR-compliant alarm and saturation values**

Level	4–20 mA (1–5 Vdc) saturation	4–20 mA (1–5 Vdc) alarm
Low	3.80 mA (0.95 V)	≤ 3.60 mA (0.90 V) (.90 –.95 V)
High	20.50 mA (5.13 V)	≥ 22.50 mA (5.63 V) (5.05 –5.75 V)

**Table 2-6: Custom alarm and saturation values**

Level	4–20 mA (1–5 Vdc) saturation	4–20 mA (1–5 Vdc) alarm
Low	3.70 mA– 3.90 mA (.90 –.95 V)	3.60–3.80 mA (.90 –.95 V)
High	20.10 mA –22.90 mA (5.025 –5.725 V)	20.20 mA – 23.00 mA (5.05 –5.75 V)

You can configure failure mode alarm and saturation levels using a communication device, AMS Device Manager, or the local operator interface (LOI). The following limitations exist for custom levels:

- Low alarm level must be less than the low saturation level
- High alarm level must be higher than the high saturation level



- Alarm and saturation levels must be separated by at least 0.1 mA (0.025 Vdc)

The configuration tool will provide an error message if the configuration rule is violated.

**Note**

Transmitters set to HART® multidrop mode send all saturation and alarm information digitally; saturation and alarm conditions will not affect the analog output.

**Related information**

[Configuring scaled variable](#)

[Establishing multidrop communication](#)

## Configure alarm and saturation levels using a communication device

**Procedure**

From the **HOME** screen, enter the fast key sequence:

**Fast keys**            2, 2, 2, 5

## Configure alarm and saturation levels using AMS Device Manager

**Procedure**

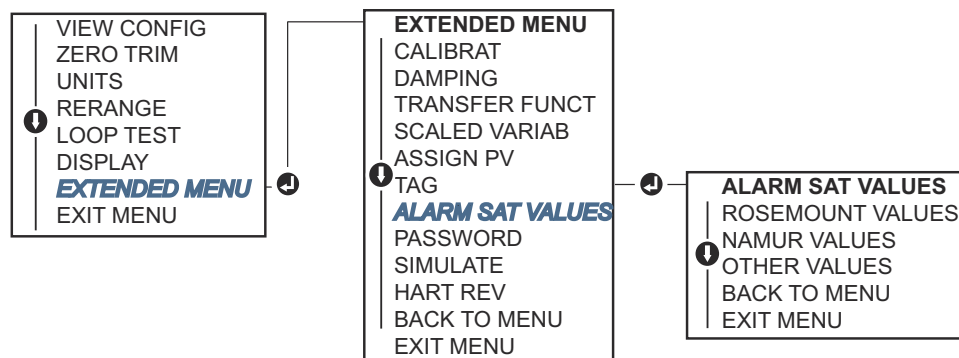
1. Right-click the device and select **Configure**.
2. Select **Configure Alarm and Saturation Levels**.
3. Follow screen prompts to configure alarm and saturation levels.

## Configure alarm and saturation levels using a local operator interface (LOI)

**Procedure**

Refer to [Figure 2-13](#) to configure alarm and saturation levels.

**Figure 2-13: Configuring alarm and saturation using LOI**



## 2.7.2 Configuring scaled variable

With the scaled variable configuration, you can create a relationship/conversion between the pressure units and user-defined/custom units. There are two use cases for a scaled

variable. The first is to allow custom units to be displayed on the transmitter's local operator interface (LOI)/LCD display. The second is to allow custom units to drive the transmitter's 4-20 mA (1-5 Vdc) output.

If you desire custom units to drive the 4-20 mA (1-5 Vdc) output, remap the scaled variable as the primary variable.

The scaled variable configuration defines the following items:

<b>Scaled variable units</b>	Custom units to be displayed
<b>Scaled data options</b>	Defines the transfer function for the application: <ul style="list-style-type: none"> <li>• Linear</li> <li>• Square root</li> </ul>
<b>Pressure value position 1</b>	Lower known value point with consideration of linear offset
<b>Scaled variable value position 1</b>	Custom unit equivalent to the lower known value point
<b>Pressure value position 2</b>	Upper known value point
<b>Scaled variable value position 2</b>	Custom unit equivalent to the upper known value point
<b>Linear offset</b>	The value required to zero out pressures effecting the desired pressure reading
<b>Low flow cutoff</b>	Point at which output is driven to zero to prevent problems cause by process noise. Emerson highly recommends using the low flow cut off function in order to have a stable output and avoid problems due to process noise at a low flow or no flow condition. Enter a low flow cutoff value that is practical for the flow element in the application.

### Related information

[Configuring scaled variable](#)

## Configure scaled variable using a communication device

### Procedure

1. From the **HOME** screen, enter the fast key sequence:
 

<b>Fast keys</b>	2, 1, 5, 7
------------------	------------
2. Follow the screen prompts to configure scaled variable.
  - When configuring for level, select `Linear` under **Select Scaled data options**.
  - When configuring for flow, select `Square Root` under **Select Scaled data options**.

## Configure scaled variable using AMS Device Manager

### Procedure

1. Right-click the device and select **Configure**.
2. Select the **Scaled Variable** tab and select the **Scaled Variable** button.
3. Follow screen prompts to configure the scaled variable.

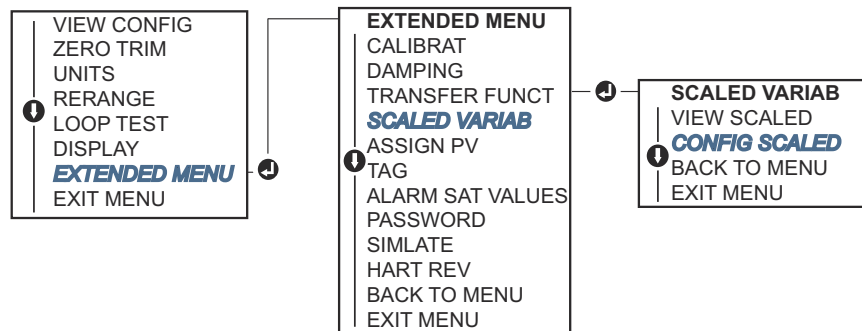
- When configuring for level applications, select `Linear` under **Select Scaled data options**.
- When configuring the flow applications, select `Square Root` under **Select Scaled data options**.

## Configure scaled variable using a local operator interface (LOI)

### Procedure

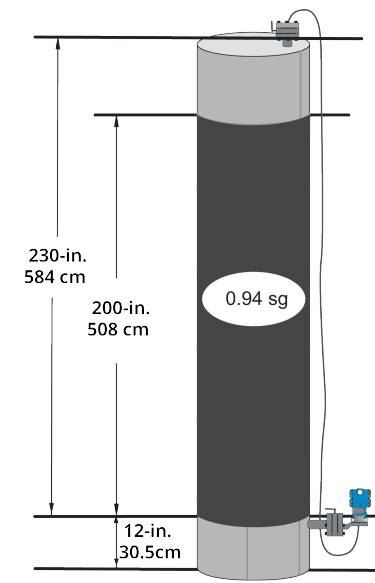
Refer to [Figure 2-14](#) to configure scaled variable using an LOI.

**Figure 2-14: Configuring scaled variable using an LOI**



## DP level example

**Figure 2-15: Example tank**



Use a differential transmitter in a level application. Once installed on an empty tank with the taps vented, the process variable reading is  $-209.4 \text{ inH}_2\text{O}$ . The process variable reading is the head pressure created by fill fluid in the capillary. Based on [Table 2-7](#), the scaled variable configuration would be as follows:

**Table 2-7: Scaled variable configuration for tank application**

Scaled variable units	inch
Scaled data options	linear
Pressure value position 1	0 inH <sub>2</sub> O
Scaled variable position 1	12 in.
Pressure value position 2	188 inH <sub>2</sub> O
Scaled variable position 2	212 in.
Linear offset	-209.4 inH <sub>2</sub> O

### DP flow example

A differential pressure transmitter is used in conjunction with an orifice plate in a flow application where the differential pressure at full scale flow is 125 inH<sub>2</sub>O.

In this particular application, the flow rate at full scale flow is 20,000 gallons of water per hour. Emerson highly recommends using the **Low flow cutoff** function in order to have a stable output and avoid problems due to process noise at a low flow or no flow condition. Enter a **Low flow cutoff** value that is practical for the flow element in the application. In this particular example, the **Low flow cutoff** value is 1000 gallons of water per hour. Based on this information, the scaled variable configuration would be as follows:

**Table 2-8: Scaled variable configuration for flow application**

Scaled variable units	gal/h
Scaled data options	square root
Pressure value position 2	125 inH <sub>2</sub> O
Scaled variable position 2	20,000 gal/h
Low flow cutoff	1000 gal/h

#### Note

**Pressure value position 1** and **Scaled Variable position 1** are always set to zero for a flow application. No configuration of these values is required.

## 2.7.3 Remapping device variables

Use the remapping function to configure the transmitter primary, secondary, tertiary, and quaternary variables (PV, 2V, 3V, and 4V). You can remap the PV using a communication device, AMS Device Manager, or the local operator interface (LOI). You can only remap the other variables (2V, 3V, and 4V) using a communication device or AMS Device Manager.

#### Note

The variable assigned to the primary variable drives the 4-20 mA (1-5 Vdc) output. You can select this value as `Pressure` or `Scaled Variable`. The 2, 3, and 4 variables only apply if you are using HART<sup>®</sup> burst mode.

### Remap using a communication device

#### Procedure

From the **HOME** screen, enter the fast key sequence:

**Fast keys**            2, 1, 1, 3

## Remap using AMS Device Manager

### Procedure

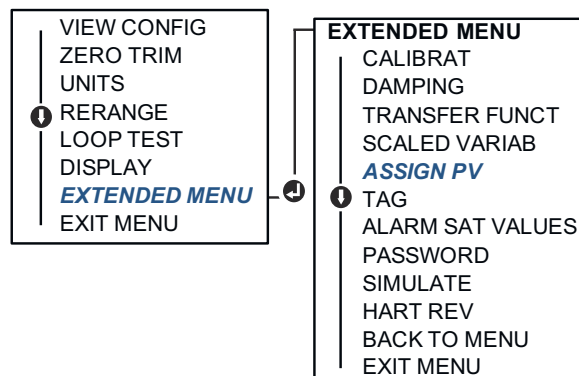
1. Right-click the device and select **Configure**.
2. Go to **Manual Setup** → **HART**.
3. Under **Variable Mapping**, assign primary, secondary, tertiary, and quaternary variables .
4. Select **Send**.
5. Carefully read the warning and select **Yes** if it is safe to apply the changes.

## Remap using a local operator interface (LOI)

### Procedure

Refer to [Figure 2-16](#) to remap the primary variable using an LOI.

**Figure 2-16: Remapping using an LOI**



## 2.8 Performing transmitter tests

### 2.8.1 Verifying alarm level

If the transmitter is repaired or replaced, verify the transmitter alarm level before returning the transmitter to service. This is useful in testing the reaction of the control system to a transmitter in an alarm state, thus ensuring the control system recognizes the alarm when activated. To verify the transmitter alarm values, perform a loop test and set the transmitter output to the alarm value.

#### Note

Before returning transmitter to service, verify security switch is set to the correct position.

#### Related information

[Configuring alarm and saturation levels](#)

[Verifying configuration](#)

### 2.8.2 Performing an analog loop test

The **analog loop test** command verifies the output of the transmitter, the integrity of the loop, and the operations of any recorders or similar devices installed in the loop.

Emerson recommends testing the 4-20 mA (1-5 Vdc) points in addition to alarm levels when installing, repairing, or replacing a transmitter.

The host system may provide a current measurement for the 4–20 mA (1-5 Vdc) HART® output. If it does not, connect a reference meter to the transmitter by either connecting the meter to the test terminals on the terminal block or shunting transmitter power through the meter at some point in the loop.

For 1-5 V output, voltage measurement is directly measured from  $V_{out}$  to (-) terminals.

## Perform an analog loop test using a communication device

### Procedure

From the **HOME** screen, enter the fast key sequence:

**Fast keys**            3, 5, 1

## Perform an analog loop test using AMS Device Manager

### Procedure

1. Right-click the device and go to **Methods** → **Diagnostics and Test** → **Loop Test**.
2. Set the control loop to **Manual** and select **Next**.
3. Follow screen prompts to perform a loop test.
4. Select **Finish** to acknowledge the method is complete.

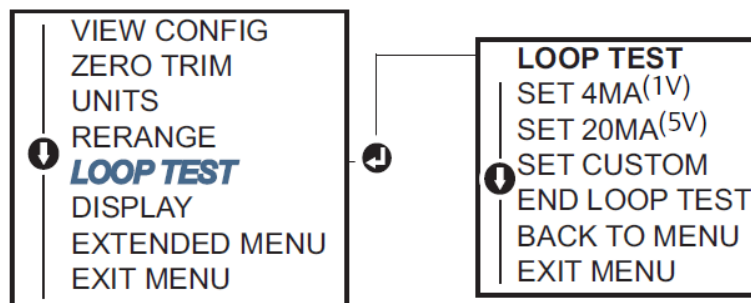
## Perform an analog loop test using a local operator interface (LOI)

To perform an analog loop test using the LOI, you may set the 4 mA (1 V), 20 mA (5 V), and custom mA points manually.

### Procedure

See [Figure 2-17](#) for instructions on performing a transmitter loop test using an LOI.

**Figure 2-17: Performing an analog loop test using an LOI**



### 2.8.3 Simulating device variables

You can temporarily set the **Pressure**, **Sensor Temperature**, or **Scaled Variable** to a user-defined fixed value for testing purposes.

Once the simulated variable method is left, the process variable will be automatically returned to a live measurement. Simulate device variables is only available in HART® Revision 7 mode.

## Simulate digital signal using a communication device

### Procedure

From the **HOME** screen, enter the fast key sequence:

**Fast keys**            3, 5

## Simulate digital signal using AMS Device Manager

### Procedure

1. Right-click the device and select `Service Tools`.
2. Select **Simulate**.
3. Under **Device Variables**, select a digital value to simulate.  
The options are:
  - Pressure
  - Sensor Temperature
  - Scaled Variable
4. Follow the screen prompts to simulate the selected digital value.

## 2.9 Configuring Burst mode

`Burst` mode is compatible with the analog signal.

Because the HART<sup>®</sup> protocol features simultaneous digital and analog data transmission, the analog value can drive other equipment in the loop while the control system is receiving the digital information. `Burst` mode applies only to the transmission of dynamic data (pressure and temperature in engineering units, pressure in percent of range, scaled variable, and/or analog output), and does not affect the way other transmitter data is accessed. However, when activated, `burst` mode can slow down communication of non-dynamic data to the host by 50 percent.

Use the normal poll/response method of HART communication to access information other than dynamic transfer data. A communication device, AMS Device Manager, or the control system may request any of the information that is normally available while the transmitter is in `Burst` mode. Between each message sent by the transmitter, a short pause allows the communication device, AMS Device Manager, or a control system to initiate a request.

### 2.9.1 Selecting Burst mode options in HART<sup>®</sup> 5

The message content options are:

- PV (primary variable) only
- Percent of range
- PV, 2V, 3V, 4V
- Process variables
- Device status

## 2.9.2 Selecting Burst mode options in HART® 7

The message content options are:

- PV (primary variable) only
- Percent of range
- PV, 2V, 3V, 4V
- Process variables and status
- Process variables
- Device status

## 2.9.3 Selecting a HART® 7 trigger mode

When in HART 7 mode, you can select one of the following the following trigger modes:

- Continuous (same as HART 5 *Burst* mode)
- Rising
- Falling
- Windowed
- On change

---

### Note

Consult host system manufacturer for **Burst** mode requirements.

---

## 2.9.4 Configure Burst mode using a communication device

### Procedure

From the **HOME** screen, enter the fast key sequence:

**Fast keys**            2, 2, 5, 3

## 2.9.5 Configure Burst mode using AMS Device Manager

### Procedure

1. Right-click the device and select **Configure**.
2. Select the **HART** tab.
3. Enter the configuration in the **Burst Mode Configuration** fields.

## 2.10 Establishing multidrop communication

Multidropping transmitters refers to the connection of several transmitters to a single communication transmission line. Communication between the host and the transmitters takes place digitally with the analog output of the transmitters deactivated.

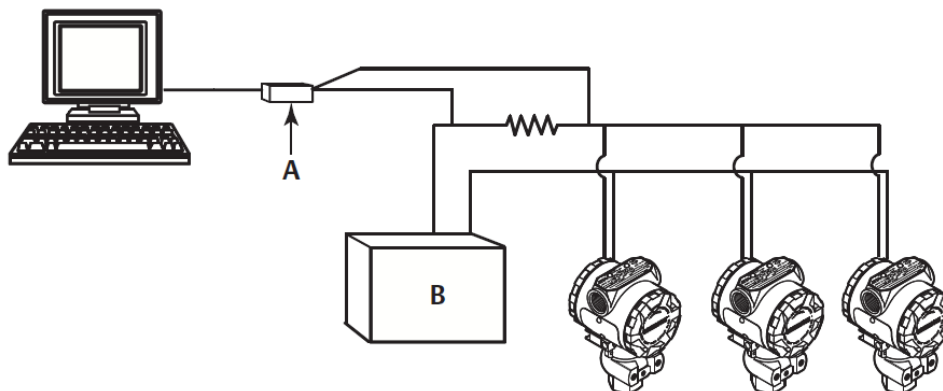
For multidrop installation, you need to consider the update rate necessary from each transmitter, the combination of transmitter models, and the length of the transmission line. You can establish communication with transmitters using HART® modems and a host implementing HART protocol. Each transmitter is identified by a unique address and responds to the commands defined in the HART protocol. Communication devices and AMS



Device Manager can test, configure, and format a multidropped transmitter the same way as a transmitter in a standard point-to-point installation.

Figure 2-18 shows a typical multidrop network. This figure is not intended as an installation diagram.

**Figure 2-18: Typical multidrop network (4–20 mA only)**



- A. HART modem
- B. Power supply

Emerson sets the product to address zero (0) at the factory, which allows operation in the standard point-to-point manner with a 4–20 mA (1–5 Vdc) output signal. To activate multidrop communication, change the transmitter address to a number from 1 to 15 for HART Revision 5, or 1–63 for HART Revision 7. This change deactivates the 4–20 mA (1–5 Vdc) analog output, sending it to 4 mA (1 Vdc). It also disables the **failure mode alarm** signal, which is controlled by the upscale/downscale switch position. Failure signals in multidropped transmitters are communicated through HART messages.

## 2.10.1 Changing a transmitter address

To activate multidrop communication, you must assign the transmitter poll address to a number from 1 to 15 for HART® Revision 5 and 1 to 63 for HART Revision 7.

Each transmitter in a multidropped loop must have a unique poll address.

### Change a transmitter address using a communication device

#### Procedure

From the **HOME** screen, enter the fast key sequence:

	HART® Revision 5	HART Revision 7
Fast keys	2, 2, 5, 2, 1	2, 2, 5, 2, 2

### Change transmitter address using AMS Device Manager

Complete the following steps to change the transmitter address, in order to activate multidrop communication, using AMS Device Manager.

#### Procedure

1. Right-click the device and select **Configure**.
2. Go to **Manual Setup** → **HART**.

3. Change the polling address.
  - In HART® Revision 5 mode, in the **Communication Settings** box, enter the polling address in the **Polling Address** field and click **Send**.
  - In HART Revision 7 mode, click the **Change Polling Address** button.
4. Carefully read the warning and click **Yes** if it is safe to apply the changes.

## 2.10.2 Communicating with a multidropped transmitter

To communicate with a multidropped transmitter, set up the communication device or AMS Device Manager for polling.

### Communicate with a multidropped transmitter using a communication device

To set up a communication device for polling:

#### Procedure

1. Go to **Utility** → **Configure HART Application**.
2. Select **Polling Addresses**.
3. Enter 0–63.

### Communicate with a multidropped transmitter using AMS Device Manager

#### Procedure

Select the HART® modem icon and select **Scan All Devices**.

## 3 Hardware installation

### 3.1 Overview

The information in this section covers installation considerations for the Rosemount 2051 with HART® protocols.

Emerson ships a Quick Start Guide with every transmitter to describe recommended pipe-fitting and wiring procedures for initial installation.

#### Related information

[Install bolts](#)

[Disassembly procedures](#)

[Reassembly procedures](#)

### 3.2 Considerations

#### 3.2.1 Installation considerations

Measurement accuracy depends upon proper installation of the transmitter and impulse piping.

Mount the transmitter close to the process and use a minimum of piping to achieve best accuracy. Keep in mind the need for easy access, personnel safety, practical field calibration, and a suitable transmitter environment. Install the transmitter to minimize vibration, shock, and temperature fluctuation.

#### NOTICE

Install the enclosed pipe plug in unused conduit opening. Engage a minimum of five threads to comply with explosion-proof requirements. For tapered threads, install the plug wrench tight. For material compatibility considerations, see [Material Selection and Compatibility Considerations for Rosemount Pressure Transmitter Technical Note](#).

#### 3.2.2 Environmental considerations

The best practice is to mount the transmitter in an environment that has minimal ambient temperature change.

The transmitter electronics operating temperature limits are -40 to +185 °F (-40 to +85 °C). Refer to the Specifications section in the [Rosemount 3051 Pressure Transmitter Product Data Sheet](#) to view the sensing element operating limits. Mount the transmitter so it is not susceptible to vibration and mechanical shock and does not have external contact with corrosive materials.

## 3.2.3 Mechanical considerations

### Steam service

#### NOTICE

For steam service or for applications with process temperatures greater than the limits of the transmitter, do not blow down impulse piping through the transmitter. Flush lines with the blocking valves closed and refill lines with water before resuming measurement.

### Side mounted

#### Note

When the transmitter is mounted on its side, position the Coplanar™ flange to ensure proper venting or draining.

Keep drain/vent connections on the bottom for gas service and on the top for liquid service.

#### Related information

[Mounting requirements](#)

## 3.3 Installation procedures

### 3.3.1 Mounting the transmitter

#### Mount process flanges

##### Procedure

Mount the process flanges with sufficient clearance for process connections.

#### ⚠ CAUTION

For safety reasons, place the drain/vent valves so the process fluid is directed away from possible human contact when the vents are used.

In addition, consider the need for a testing or calibration input.

#### NOTICE

Most transmitters are calibrated in the horizontal position. Mounting the transmitter in any other position will shift the zero point to the equivalent amount of liquid head pressure caused by the varied mounting position.

#### Related information

[Trimming the pressure signal](#)

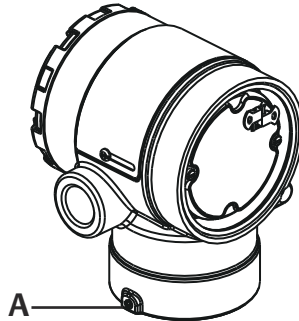
## Rotate housing

You can rotate the electronics housing up to 180 degrees in either direction to improve field access to wiring or to better view the optional LCD display.

### Procedure

1. Loosen the housing rotation set screw using a 5/64-inch hex wrench.

**Figure 3-1: Housing rotation**



*A. Housing rotation set screw (5/64-in.)*

2. Rotate the housing clockwise to the desired location.
3. If the desired location cannot be achieved due to thread limitation, rotate the housing counterclockwise to the desired location (up to 360° from thread limit).
4. Retighten the housing rotation set screw to no more than 7 in.-lbs. when desired location is reached.

## Electronics housing clearance

Mount the transmitter so the terminal side is accessible.

To remove the cover, ensure there is clearance of 0.75 in. (19 mm). Use a conduit plug in the unused conduit opening. You need 3 in. (76 mm) of clearance to remove the cover if a meter is installed.

## Environmental seal for housing

### NOTICE

For NEMA® 4X, IP66, and IP68 requirements, use thread seal (PTFE) tape or paste on male threads of conduit to provide a watertight seal.

Always ensure a proper seal by installing the electronics housing cover(s) so that metal contacts metal.

Use Rosemount O-rings.

## Flange bolts

Emerson can ship the Rosemount 2051 with a Coplanar™ flange or a traditional flange installed with four 1.75-inch flange bolts.

Stainless steel bolts supplied by Emerson are coated with a lubricant to ease installation. Carbon steel bolts do not require lubrication. Do not apply any additional lubricant when

installing either type of bolt. Bolts supplied by Emerson are identified by their head markings.

### Related information

[Install bolts](#)

## Install bolts

### NOTICE

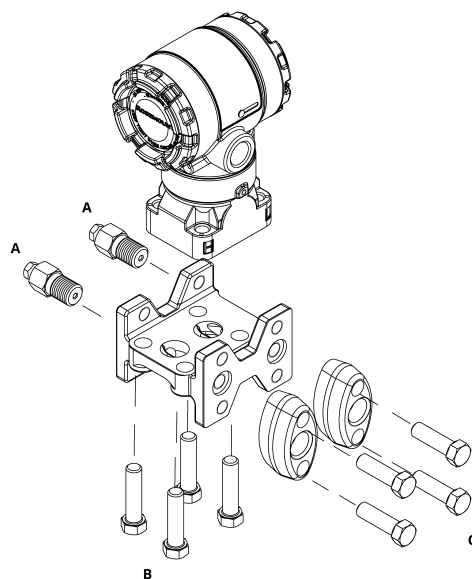
The use of non-approved bolts could reduce pressure.

Only use bolts supplied with the transmitter or sold by Emerson as spare parts.

**Table 3-1: Bolt installation torque values**

Bolt material	Initial torque value	Final torque value
Carbon steel (CS)-(ASTM-A445) standard	300 in.-lb. (34 N-m)	650 in.-lb. (73 N-m)
Austenitic 316 stainless steel (SST)—Option L4	150 in.-lb. (17 N-m)	300 in.-lb. (34 N-m)
ASTM A193 Grade B7M—Option L5	300 in.-lb. (34 N-m)	650 in.-lb. (73 N-m)
ASTM A 193 Class 2, Grade B8M option L8	300 in.-lb (34 N-m)	650 in.-lb (73 N-m)

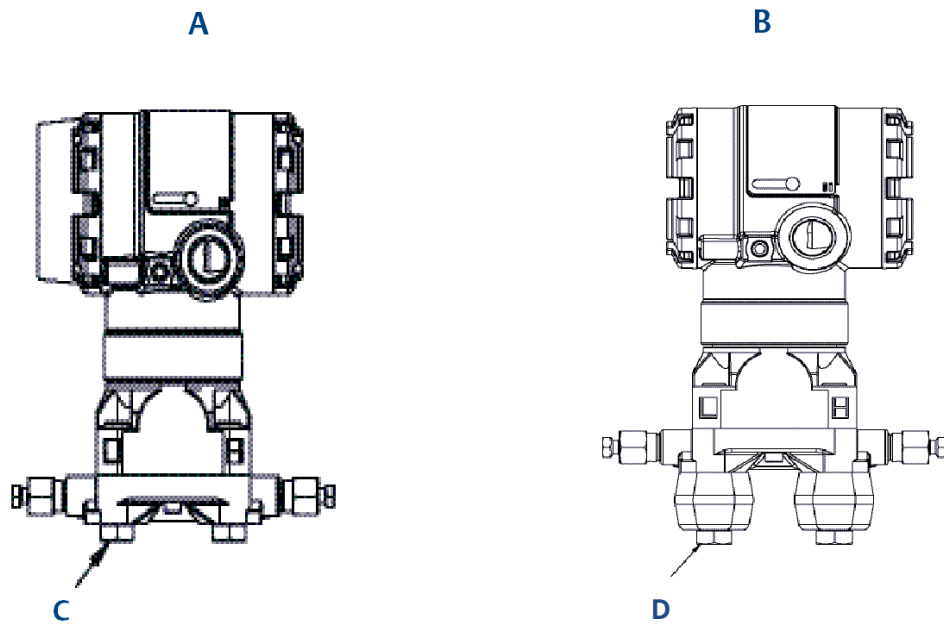
**Figure 3-2: Rosemount 2051 differential transmitter**



- A. Drain/vent
- B. 1.75 in. (44 mm) × 4
- C. 1.50 in. (38 mm) × 4<sup>(1)</sup>

<sup>(1)</sup> For gauge and absolute transmitters: 150 (38) × 2

Figure 3-3: Mounting bolts and bolt configurations for coplanar flange



- A. Transmitter with flange bolts
- B. Transmitter with flange adapters and flange/adapter bolts
- C. 1.75 in. (44 mm) × 4
- D. 2.88 in. (73 mm) × 4

Table 3-2: Bolt configurations values

Description	Quantity	Size in. (mm)
<b>Differential pressure</b>		
Flange bolts	4	1.75 (44)
Flange/adapter bolts	4	2.88 (73)
<b>Gauge/absolute pressure<sup>(1)</sup></b>		
Flange bolts	4	1.75 (44)
Flange/adapter bolts	2	2.88 (73)

(1) Rosemount 2051T Transmitters are direct mount and do not require bolts for process connection.

Figure 3-4: Mounting bracket option codes B1, B7, and BA

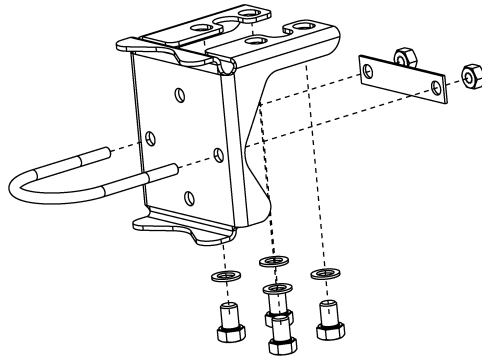
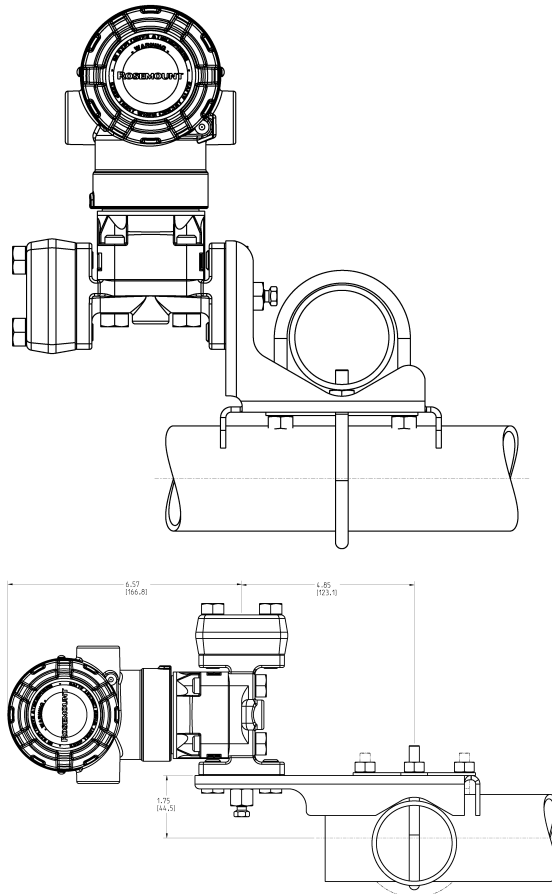


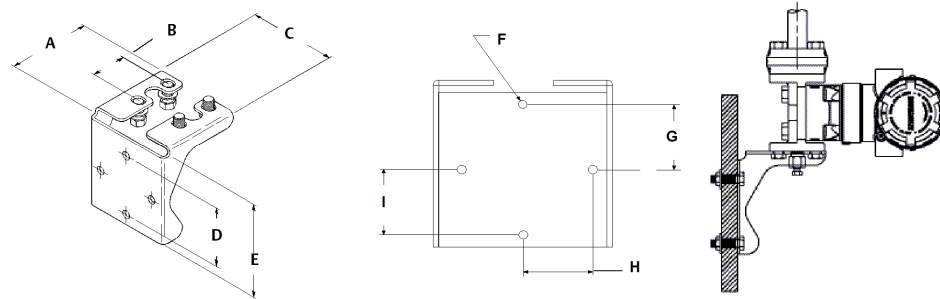
Figure 3-5: 2051C pipe mounted



**Note**  
Dimensions are in inches (mm).

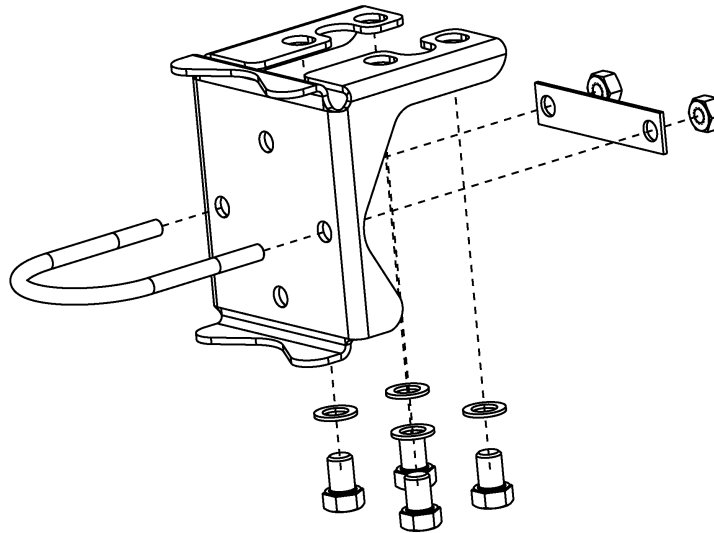


**Figure 3-6: Panel mounting bracket option codes B2 and B8**



- A. 3.75 (95)
- B. 1.63 (41)
- C. 4.09 (104)
- D. 2.81 (71)
- E. 4.5 (114)
- F. Mounting holes 0.375 diameter (10)
- G. 1.405 (35.7)
- H. 1.405 (35.7)
- I. 1.40 (36)

**Figure 3-7: Flat mounting bracket option codes B3 and BC**



**Procedure**

1. Finger-tighten the bolts.
2. Torque the bolts to the initial torque value using a crossing pattern (see [Table 3-1](#) for torque values).
3. Torque the bolts to the final torque value using the same crossing pattern.

## Mounting brackets

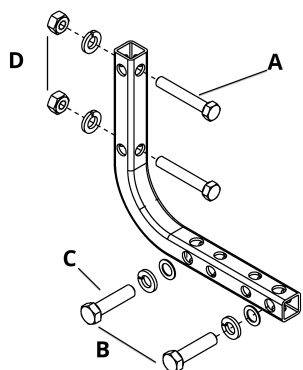
You may panel-mount or pipe-mount Rosemount 2051 Transmitters via an optional mounting bracket.

Refer to [Table 3-3](#) for the complete offering and see [Figure 3-8](#) for dimensional and mounting configuration information.

**Table 3-3: Mounting brackets**

Option code	Process connections			Mounting			Materials			
	Coplanar	In-line	Traditional	Pipe mount	Panel mount	Flat panel mount	Carbon steel (CS) bracket	Stainless steel (SST) bracket	CS bolts	SST bolts
B4	X	X		X	X	X		X		X
B1			X	X			X		X	
B2			X		X		X		X	
B3			X			X	X		X	
B7			X	X			X			X
B8			X		X		X			X
B9			X			X	X			X
BA			X	X				X		X
BC			X			X		X		X

**Figure 3-8: Mounting bracket option code B4**



- A.  $5/16 \times 1\frac{1}{2}$  bolts for panel mounting(not supplied)
- B. 3.4 in. (85 mm)
- C.  $3/8-16 \times 1\frac{1}{4}$  bolts for mounting to transmitter
- D. 2.8 in. (71 mm)
- E. 6.90 in. (175 mm)

Figure 3-9: Mounting bracket option code B4 U-bolt

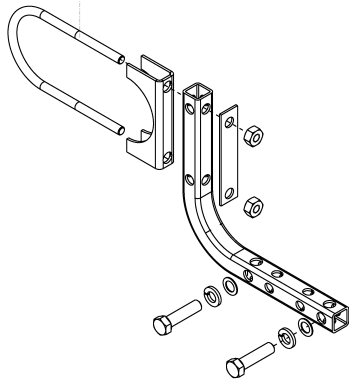
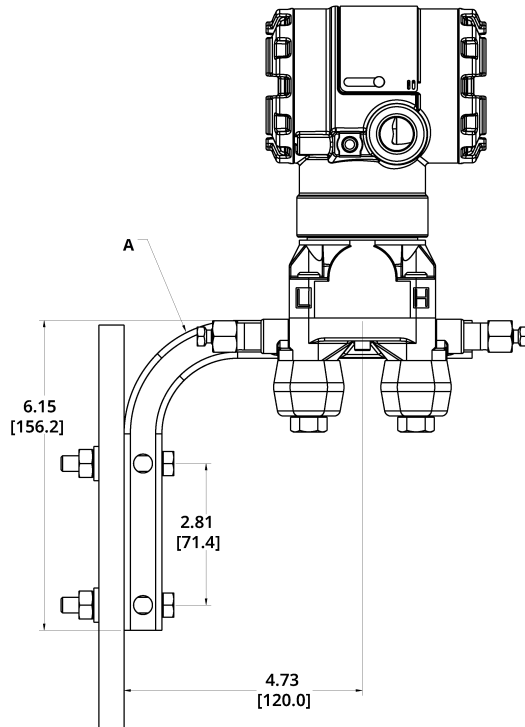


Figure 3-10: 2051C Coplanar Transmitter B4 mounting option

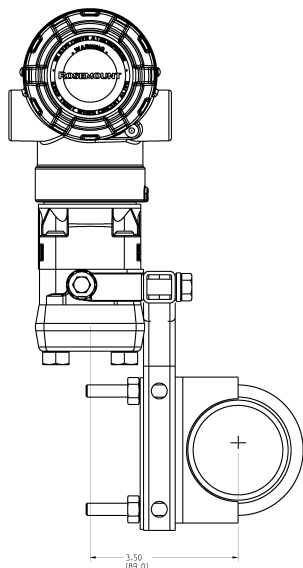


A. Drain/vent valve

**Note**

Dimensions are in inches (mm).

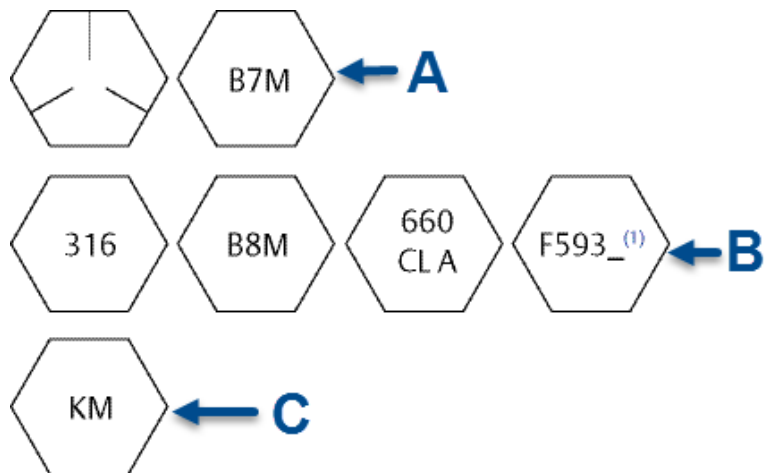
Figure 3-11: 2051C Coplanar Transmitter process flange connection



**Note**

Dimensions are in inches (mm).

Figure 3-12: Head markings



- A. Carbon steel (CS) head markings
- B. Stainless steel (SST) head markings
- C. Alloy K-500 head marking

**Note**

The last digit in the F593\_head marking may be any letter between A and M.

## 3.3.2 Impulse piping

### Mounting requirements

Impulse piping configurations depend on specific measurement conditions.

Refer to [Figure 3](#) for examples of the following mounting configurations:

#### Liquid flow measurement

- Place taps to the side of the line to prevent sediment deposits on the process isolators.
- Mount the transmitter beside or below the taps so gases vent into the process line.
- Mount drain/vent valve upward to allow gases to vent.

#### Gas flow measurement

- Place taps in the top or side of the line.
- Mount the transmitter beside or above the taps so to drain liquid into the process line.

#### Steam flow measurement

- Place taps to the side of the line.
- Mount the transmitter below the taps to ensure that impulse piping will remain filled with condensate.
- In steam service above +250 °F (+121 °C), fill impulse lines with water to prevent steam from contacting the transmitter directly and to ensure accurate measurement startup.

### NOTICE

For steam or other elevated temperature services, it is important that temperatures at the process connection do not exceed the transmitter's process temperature limits. See Temperature Limits in the [2051 Product Data Sheet](#) for details.

**Figure 3-13: Liquid applications installation example**

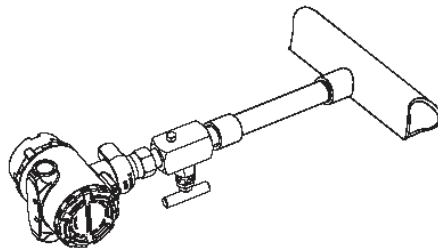
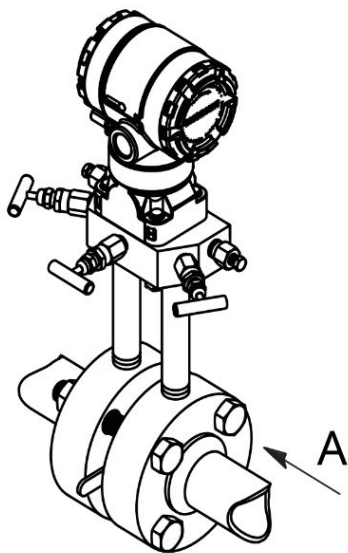
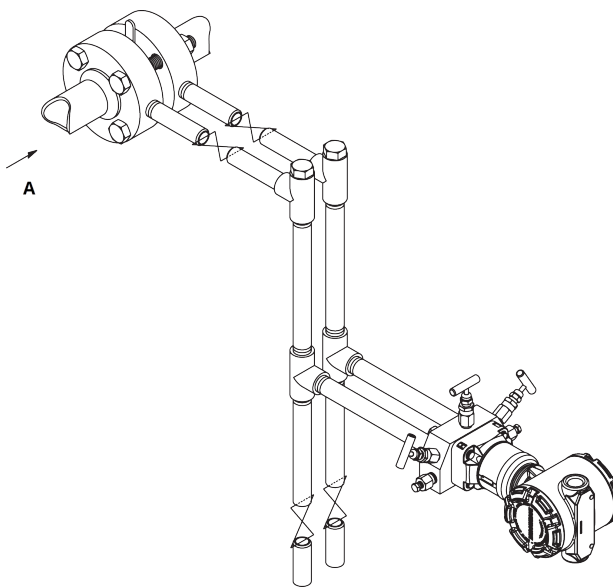


Figure 3-14: Gas installation example



A. Flow

Figure 3-15: Steam applications installation example



A. Flow

### Best practices

The piping between the process and the transmitter must accurately transfer the pressure to obtain accurate measurements.

There are six possible sources of error:

- Pressure transfer

- Leaks
- Friction loss (particularly if purging is used)
- Trapped gas in a liquid line
- Liquid in a gas line
- Density variations between the legs

The best location for the transmitter in relation to the process pipe is dependent on the process. Use the following guidelines to determine transmitter location and placement of impulse piping:

- Keep impulse piping as short as possible.
- For liquid service, slope the impulse piping at least 1 in./ft. (8 cm/m) upward from the transmitter toward the process connection.
- For gas service, slope the piping at least 1 in./ft. (8 cm/m) downward from the transmitter toward the process connection.
- Avoid high points in liquid lines and low points in gas lines.
- Use impulse piping large enough to avoid friction effects and blockage.
- Vent all gas from liquid piping legs.
- When purging, make the purge connection close to the process taps and purge through equal lengths of the same size pipe. Avoid purging through the transmitter.
- Keep corrosive or hot (above 250 °F [121 °C]) process material out of direct contact with the sensor modules and flanges.
- Prevent sediment deposits in the impulse piping.
- Avoid conditions that might allow process fluids to freeze within the process flange.

### 3.3.3 Process connections

#### Coplanar or traditional process connection

##### NOTICE

Install and tighten all four flange bolts before applying pressure, or process leakage will result.

When properly installed, the flange bolts will protrude through the top of the sensor module housing.

Do not attempt to loosen or remove the flange bolts while the transmitter is in service.

#### Install flange adapters

Rosemount 2051 differential pressure (DP) and gauge pressure (GP) process connections on the transmitter flanges are ¼–18 NPT.

Flange adapters are available with standard ½–14 NPT Class 2 connections. The flange adapters allow you to disconnect from the process by removing the flange adapter bolts. Use plant-approved lubricant or sealant when making the process connections. This distance may be varied  $\pm\frac{1}{4}$  in. (6 mm) by rotating one or both of the flange adapters.

##### Procedure

1. Remove the flange bolts.

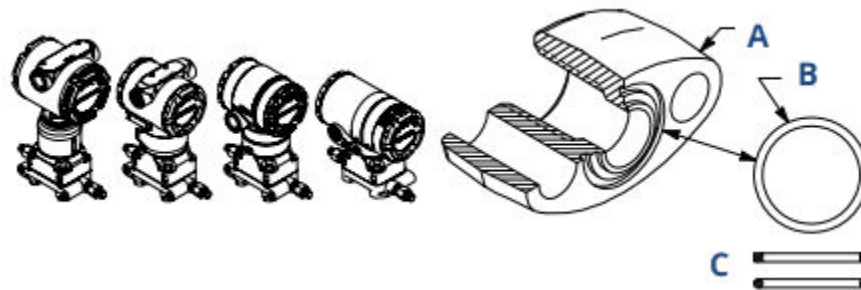
2. Leaving the flange in place, move the adapters into position with the O-ring installed.
3. Clamp the adapters and the coplanar flange to the transmitter sensor module using the larger of the bolts supplied.
4. Tighten the bolts.

**⚠ WARNING**

Failure to install proper flange adapter O-rings may cause process leaks, which can result in death or serious injury.

The two flange adapters are distinguished by unique O-ring grooves. Only use the O-ring that is designed for its specific flange adapter, as shown in [Figure 3-16](#). Replace PTFE O-rings if the flange adapter is removed.

**Figure 3-16: Rosemount 3051S/3051/2051/3095**



- A. Flange adapter
- B. O-ring
- C. PTFE-based elastomer

When removing flanges or adapters, visually inspect the PTFE O-rings. Replace with O-rings designed for Rosemount transmitters if there are any signs of damage, such as nicks or cuts. You can reuse undamaged O-rings. If you replace the O-rings, re-torque the flange bolts after installation to compensate for cold flow.

**NOTICE**

Replace PTFE O-rings if you remove the flange adapter.

**Related information**

[Flange bolts](#)

[Troubleshooting](#)



### 3.3.4 Inline process connection

#### Inline gauge transmitter orientation

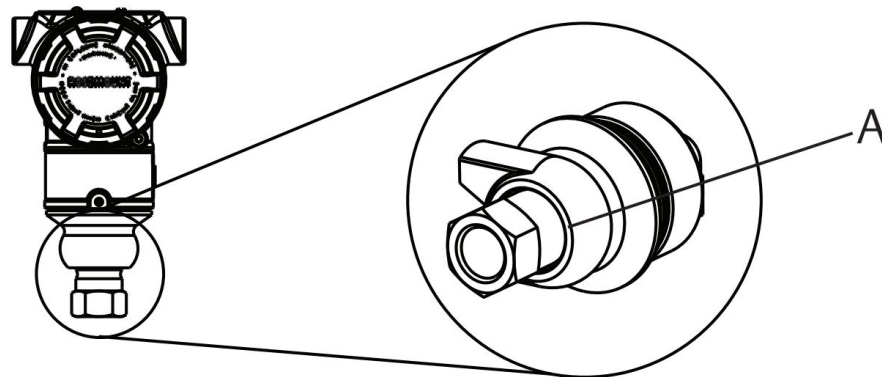
##### NOTICE

The transmitter may output erroneous pressure values.  
Do not interfere or block the atmospheric reference port.

The low side pressure port on the inline gauge transmitter is located in the neck of the transmitter, behind the housing. The vent path is 360 degrees around the transmitter between the housing and sensor (see [Figure 3-17](#)).

Keep the vent path free of any obstruction, such as paint, dust, and lubrication, by mounting the transmitter so that the process can drain away.

**Figure 3-17: Inline gauge low side pressure port**



*A. Low side pressure port (atmospheric reference)*

##### NOTICE

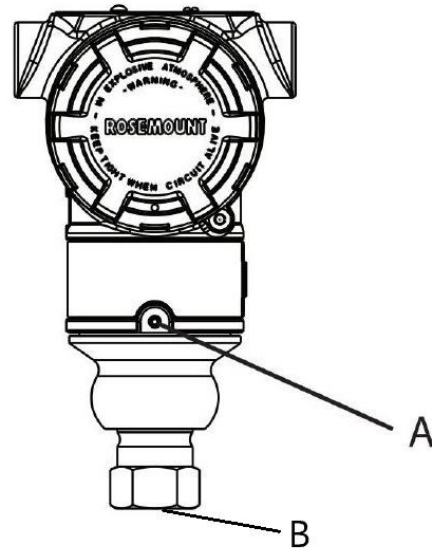
#### Electronics damage

Rotation between the sensor module and the process connection can damage the electronics.

Do not apply torque directly to the sensor module.

To avoid damage, apply torque only to the hex-shaped process connection. See [Figure 3-18](#).

Figure 3-18: Inline gauge



- A. Sensor module
- B. Process connection

## 3.4 Rosemount 304, 305, and 306 Manifolds

The 305 Integral Manifold is available in two designs: Traditional and Coplanar™.

You can mount the traditional 305 Integral Manifold to most primary elements with mounting adapters in the market today. The 306 Integral Manifold is used with the 2051T In-Line Transmitters to provide block-and-bleed valve capabilities of up to 10,000 psi (690 bar).

### 3.4.1 Install 305 Integral Manifold

#### Procedure

1. Inspect the PTFE sensor module O-rings.  
You may reuse undamaged O-rings. If the O-rings are damaged (if they have nicks or cuts, for example), replace with O-rings designed for Rosemount transmitters.

#### NOTICE

If replacing the O-rings, take care not to scratch or deface the O-ring grooves or the surface of the isolating diaphragm while you remove the damaged O-rings.

2. Install the integral manifold on the sensor module. Use the four 2¼-inch (57 mm) manifold bolts for alignment. Finger tighten the bolts; then tighten the bolts incrementally in a cross pattern to final torque value.  
When fully tightened, the bolts should extend through the top of the sensor module housing.
3. If you have replaced the PTFE sensor module O-rings, re-tighten the flange bolts after installation to compensate for cold flow of the O-rings.

## NOTICE

Always perform a zero trim on the transmitter/manifold assembly after installation to eliminate mounting effects.

### Related information

[Flange bolts](#)

## 3.4.2 Install Rosemount 306 Integral Manifold

The 306 Manifold is for use only with in-line pressure transmitters, such as the 3051T and 2051T.

Assemble the 306 Manifold to the in-line transmitters with a thread sealant.

## 3.4.3 Install 304 Conventional Manifold

### Procedure

1. Align the conventional manifold with the transmitter flange. Use the four manifold bolts for alignment.
2. Finger tighten the bolts; then tighten the bolts incrementally in a cross pattern to the final torque value.  
When fully tightened, the bolts extend through the top of the sensor module housing.
3. Leak-check assembly to maximum pressure range of transmitter.

### Related information

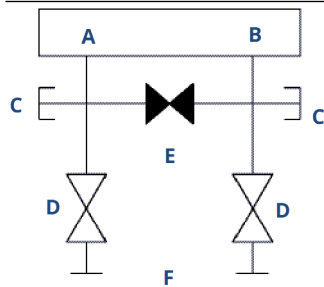
[Flange bolts](#)

## 3.4.4 Integral manifold operation

### Operate three-valve manifold

#### Prerequisites

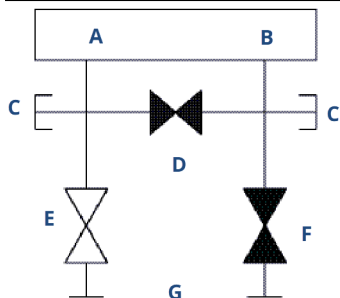
In normal operation, the two block valves between the process and instrument ports will be open, and the equalizing valve(s) will be closed.



- A. High
- B. Low
- C. Drain/vent valve
- D. Isolate (open)
- E. Equalize (closed)
- F. Process

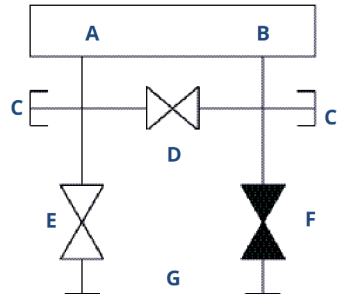
### Procedure

1. To zero the transmitter, close the isolate valve to the low pressure (downstream) side of the transmitter first.



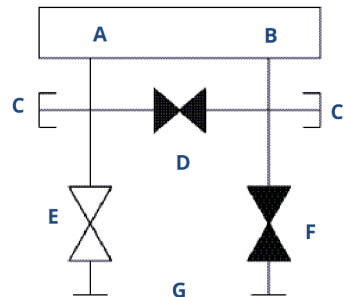
- A. High
- B. Low
- C. Drain/vent valve
- D. Equalize (closed)
- E. Isolate (open)
- F. Isolate (closed)
- G. Process

2. Open the center (equalize) valve to equalize the pressure on both sides of the transmitter.  
The valves are now in the proper configuration for zeroing the transmitter.



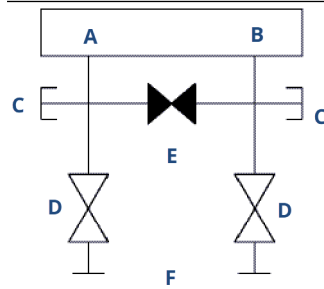
- A. High
- B. Low
- C. Drain/vent valve
- D. Equalize (open)
- E. Isolate (open)
- F. Isolate (closed)
- G. Process

3. After zeroing the transmitter, close the equalizing valve.



- A. High
- B. Low
- C. Drain/vent valve
- D. Equalize (closed)
- E. Isolate (open)
- F. Isolate (closed)
- G. Process

4. Open the isolate valve on the low pressure side of the transmitter to return the transmitter to service.

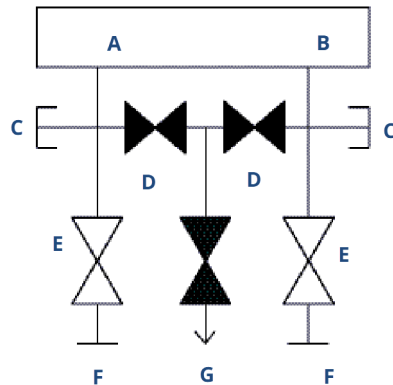


- A. High
- B. Low
- C. Drain/vent valve
- D. Isolate (open)
- E. Equalize (closed)
- F. Process

### Operate five-valve manifold

Five-valve natural gas configurations are shown.

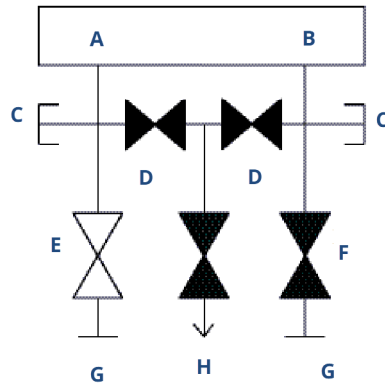
In normal operation, the two block valves between the process and instrument ports will be open, and the equalizing valves will be closed.



- A. High
- B. Low
- C. Test (plugged)
- D. Equalize (closed)
- E. Isolate (open)
- F. Process
- G. Drain vent (closed)

### Procedure

1. To zero the transmitter, first close the block valve on the low pressure (downstream) side of the transmitter.



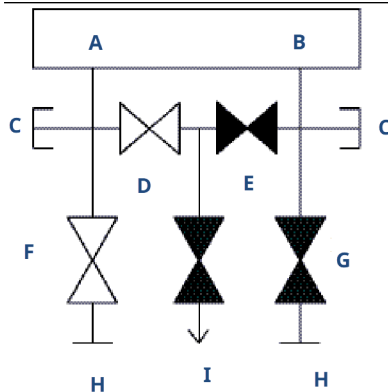
- A. High
- B. Low
- C. Test (plugged)
- D. Equalize (closed)
- E. Isolate (open)
- F. Isolate (closed)
- G. Process
- H. Drain vent

### NOTICE

Opening the low side equalize valve before the high side equalize valve will overpressure the transmitter.

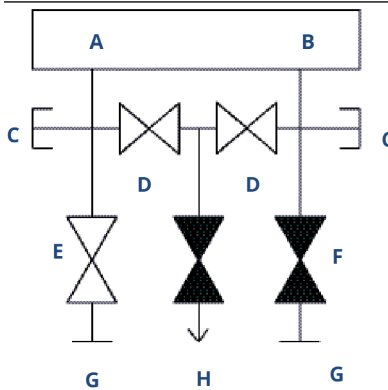
Do not open the low side equalize valve before the high side equalize valve.

2. Open the equalize valve on the high pressure (upstream) side of the transmitter.



- A. High
- B. Low
- C. Test (plugged)
- D. Equalize (open)
- E. Equalize (closed)
- F. Isolate (open)
- G. Isolate (closed)
- H. Process
- I. Drain vent (closed)

3. Open the equalize valve on the low pressure (downstream) side of the transmitter. The manifold is now in the proper configuration for zeroing the transmitter.



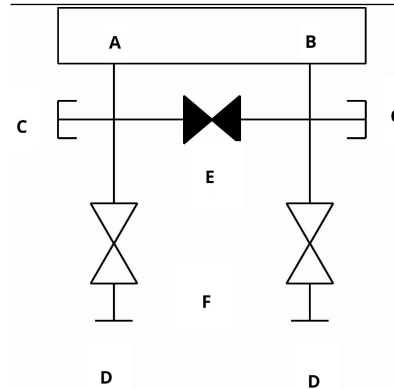
- A. High
- B. Low
- C. Test (plugged)
- D. Equalize (open)
- E. Isolate (open)
- F. Isolate (closed)
- G. Process
- H. Drain vent (closed)



## Perform a zero trim on 3 and 5-valve manifolds

Perform zero trim at static line pressure.

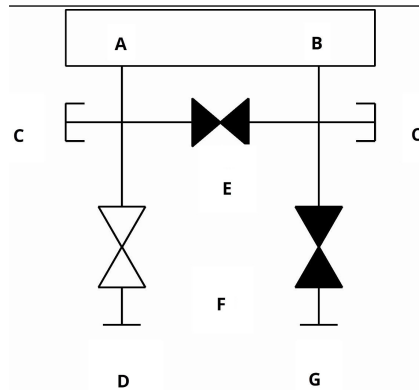
In normal operation, the two isolate (block) valves between the process ports and the transmitter will be open, and the equalize valve will be closed.



- A. High
- B. Low
- C. Drain/vent valve
- D. Isolate (open)
- E. Equalize (closed)
- F. Process

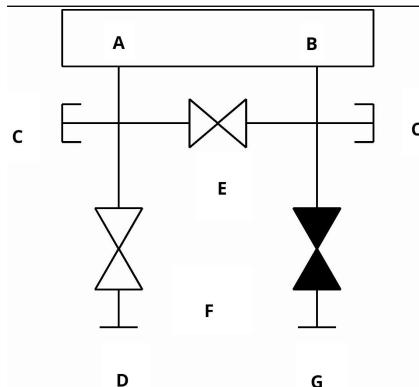
### Procedure

1. To zero trim the transmitter, close the isolate valve on the low side (downstream) side of the transmitter.



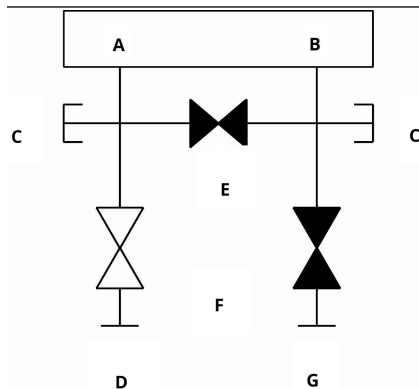
- A. High
- B. Low
- C. Drain/vent valve
- D. Isolate (open)
- E. Equalize (closed)
- F. Process
- G. Isolate (closed)

2. Open the equalize valve to equalize the pressure on both sides of the transmitter. The manifold is now in the proper configuration for performing a zero trim on the transmitter.



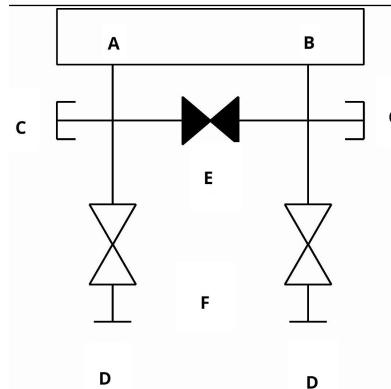
- A. High
- B. Low
- C. Drain/vent valve
- D. Isolate (open)
- E. Equalize (open)
- F. Process
- G. Isolate (closed)

3. After zeroing the transmitter, close the equalize valve.



- A. High
- B. Low
- C. Drain/vent valve
- D. Isolate (open)
- E. Equalize (closed)
- F. Process
- G. Isolate (closed)

4. Finally, to return the transmitter to service, open the low side isolate valve.

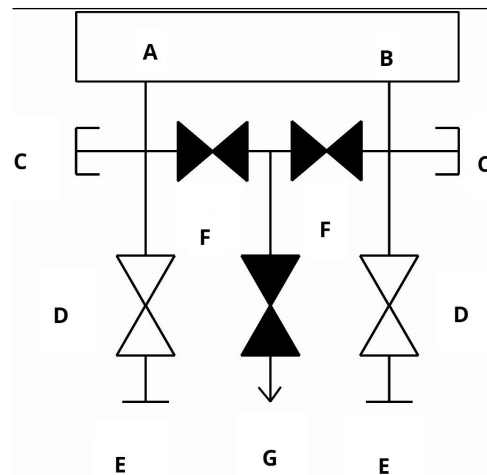


- A. High
- B. Low
- C. Drain/vent valve
- D. Isolate (open)
- E. Equalize (closed)
- F. Process

### Zero a five-valve natural gas manifold

Perform zero trim at static line pressure.

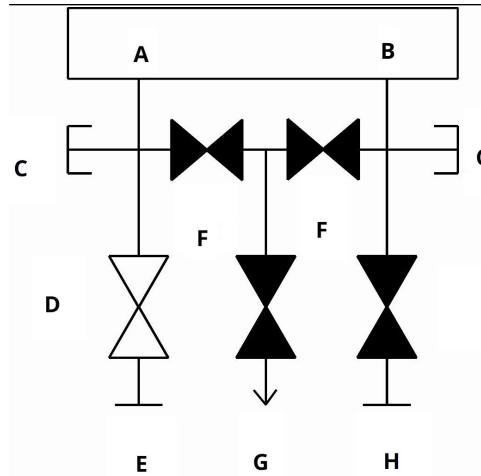
In normal operation, the two isolate (block) valves between the process ports and the transmitter will be open, and the equalize valves will be closed. Vent valves may be open or closed.



- A. High
- B. Low
- C. Plugged
- D. Isolate (open)
- E. Process
- F. Equalize (closed)
- G. Drain vent (closed)

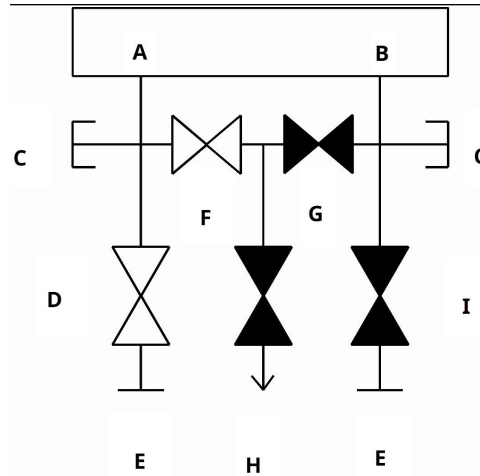
**Procedure**

1. To zero trim the transmitter, first close the isolate valve on the low pressure (downstream) side of the transmitter and the vent valve.



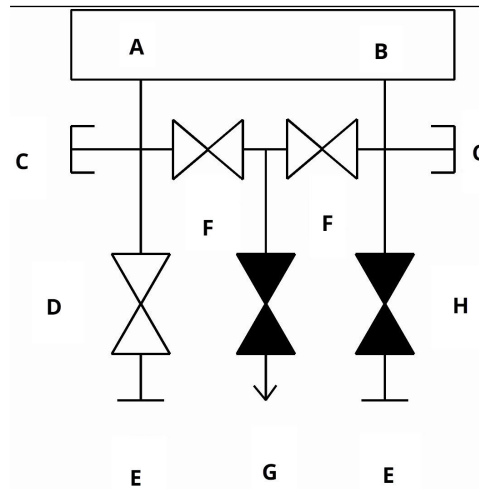
- A. High
- B. Low
- C. Plugged
- D. Isolate (open)
- E. Process
- F. Equalize (closed)
- G. Drain vent (closed)
- H. Isolate (closed)

2. Open the equalize valve on the high pressure (upstream) side of the transmitter.



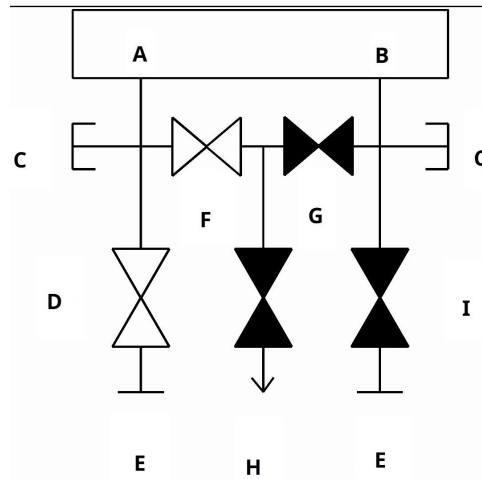
- A. High
- B. Low
- C. Plugged
- D. Isolate (open)
- E. Process
- F. Equalize (open)
- G. Equalize (closed)
- H. Drain vent (closed)
- I. Isolate (closed)

3. Open the equalize valve on the low pressure (downstream) side of the transmitter. The manifold is now in the proper configuration for zeroing the transmitter.



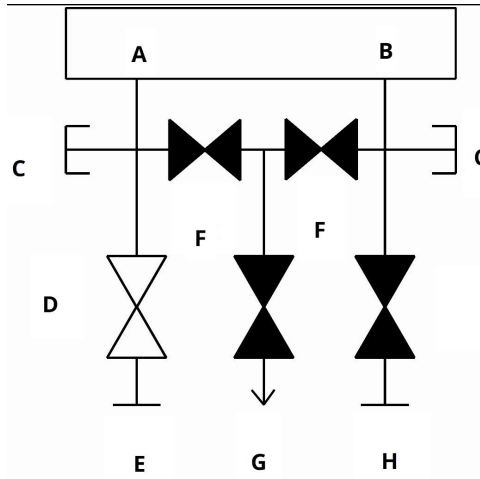
- A. High
- B. Low
- C. Plugged
- D. Isolate (open)
- E. Process
- F. Equalize (open)
- G. Drain vent (closed)
- H. Isolate (closed)

4. After zeroing the transmitter, close the equalize valve on the low pressure (downstream) side of the transmitter.



- A. High
- B. Low
- C. Plugged
- D. Isolate (open)
- E. Process
- F. Equalize (open)
- G. Equalize (closed)
- H. Drain vent (closed)
- I. Isolate (closed)

5. Close the equalize valve on the high pressure (upstream) side.

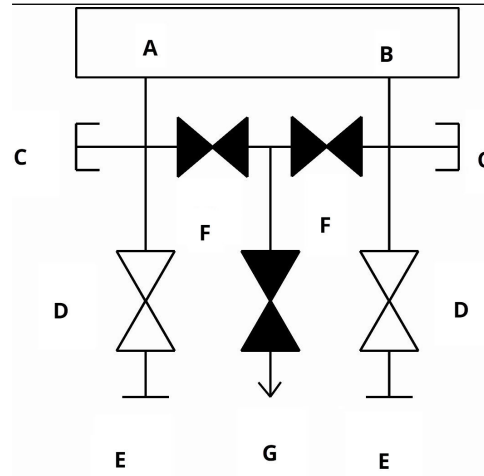


- A. High
- B. Low
- C. Plugged
- D. Isolate (open)
- E. Process
- F. Equalize (closed)
- G. Drain vent (closed)
- H. Isolate (closed)



6. Finally, to return the transmitter to service, open the low side isolate valve and vent valve.

The vent valve can remain open or closed during operation.



- A. High
- B. Low
- C. Plugged
- D. Isolate (open)
- E. Process
- F. Equalize (closed)
- G. Drain vent (closed)

### 3.4.5 Adjust valve packing

Over time, the packing material inside a Rosemount manifold may require adjustment in order to continue to provide proper pressure retention.

Not all manifolds have this adjustment capability. The manifold model number will indicate what type of stem seal or packing material has been used.

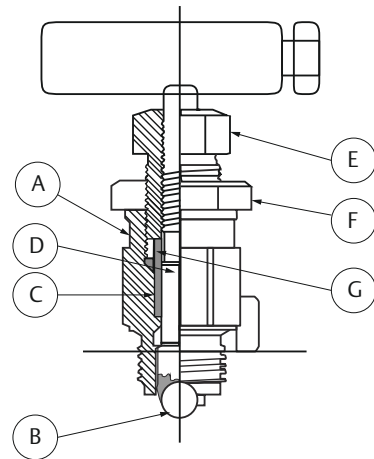
#### Procedure

1. Remove all pressure from device.
2. Loosen manifold valve jam nut.
3. Tighten manifold valve packing adjuster nut turn.
4. Tighten manifold valve jam nut.
5. Re-apply pressure and check for leaks.

#### Postrequisites

You can repeat the above steps, if necessary. If the procedure does not result in proper pressure retention, replace the complete manifold.

Figure 3-19: Valve components



- A. Bonnet
- B. Ball seat
- C. Packing
- D. Stem
- E. Packing adjuster
- F. Jam nut
- G. Packing follower

## 3.5 Liquid level measurement

Differential pressure transmitters used for liquid level applications measure hydrostatic pressure head. Liquid level and specific gravity of a liquid are factors in determining pressure head. This pressure is equal to the liquid height above the tap multiplied by the specific gravity of the liquid. Pressure head is independent of volume or vessel shape.

### 3.5.1 Open vessels

A pressure transmitter mounted near a tank bottom measures the pressure of the liquid above.

Make a connection to the high pressure side of the transmitter and vent the low pressure side to the atmosphere. Pressure head equals the liquid's specific gravity multiplied by the liquid height above the tap.

Zero range suppression is required if the transmitter lies below the zero point of the desired level range. [Figure 3-20](#) shows a liquid level measurement example.

### 3.5.2 Closed vessels

Pressure above a liquid affects the pressure measured at the bottom of a closed vessel. The liquid specific gravity multiplied by the liquid height plus the vessel pressure equals the pressure at the bottom of the vessel.

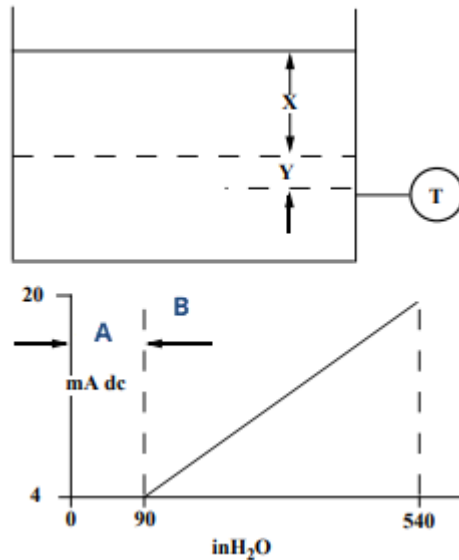
To measure true level, you must subtract the vessel pressure from the vessel bottom pressure. To do this, make a pressure tap at the top of the vessel and connect this to the low side of the transmitter. Vessel pressure is then equally applied to both the high and

low sides of the transmitter. The resulting differential pressure is proportional to liquid height multiplied by the liquid specific gravity.

### Dry leg condition

Low-side transmitter piping will remain empty if gas above the liquid does not condense. This is a dry leg condition. Range determination calculations are the same as those described for bottom-mounted transmitters in open vessels, as shown in [Figure 3-20](#).

**Figure 3-20: Liquid level measurement example**



- A. Zero
- B. Suppression

Let  $X$  equal the vertical distance between the minimum and maximum measurable levels (500 in.).

Let  $Y$  equal the vertical distance between the transmitter datum line and the minimum measurable level (100 in.).

Let  $SG$  equal the specific gravity of the fluid (0.9).

Let  $h$  equal the maximum head pressure to be measured in inches of water.

Let  $e$  equal head pressure produced by  $Y$  expressed in inches of water.

Let Range equal  $e$  to  $e + h$

$$\text{Then } h = (X)(SG)$$

$$= 500 \times 0.9$$

$$= 450 \text{ inH}_2\text{O}$$

$$e = (Y)(SG)$$

$$100 \times 0.9$$

$$90 \text{ inH}_2\text{O}$$

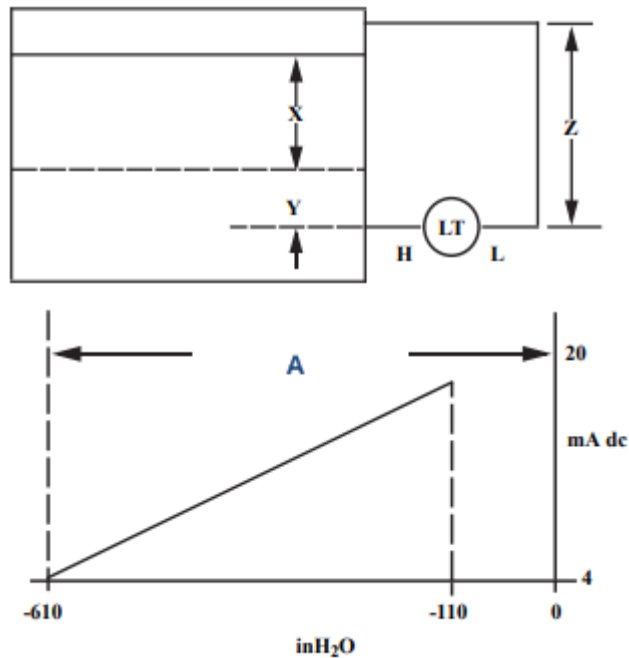
$$\text{Range} = 90 \text{ to } 540 \text{ inH}_2\text{O}$$

### Wet leg condition

Condensation of the gas above the liquid slowly causes the low side of the transmitter piping to fill with liquid. The pipe is purposely filled with a convenient reference fluid to eliminate this potential error. This is a wet leg condition.

The reference fluid will exert a head pressure on the low side of the transmitter. Zero elevation of the range must then be made. See [Figure 3-21](#).

Figure 3-21: Wet leg example



Let  $X$  equal the vertical distance between the minimum and maximum measurable levels (500 in.).

Let  $Y$  equal the vertical distance between the transmitter datum line and the minimum measurable level (50 in.).

Let  $Z$  equal the vertical distance between the top of the liquid in the wet leg and the transmitter datum line (600 in.).

Let  $SG_1$  equal the specific gravity of the fluid (1.0).

Let  $SG_2$  equal the specific gravity of the fluid in the wet leg (1.1).

Let  $h$  equal the maximum head pressure to be measured in inches of water.

Let  $e$  equal the head pressure produced by  $Y$  expressed in inches of water.

Let  $s$  equal head pressure produced by  $Z$  expressed in inches of water.

Let Range equal  $e - s$  to  $h + e - s$ .

Then  $h = (X)(SG_1)$

$= 500 \times 1.0$

$= 500 \text{ inH}_2\text{O}$

$e = (Y)(SG_1)$

$= 50 \times 1.0$

$= 50 \text{ inH}_2\text{O}$

$s = (Z)(SG_2)$

$= 600 \times 1.1$

$= 600 \text{ inH}_2\text{O}$

$$\begin{aligned}\text{Range} &= e - s \text{ to } h + e - s \\ &= 50 - 660 \text{ to } 500 + 50 - 660 \\ &= -610 \text{ to } -110 \text{ inH}_2\text{O}\end{aligned}$$

*A. Zero elevation*

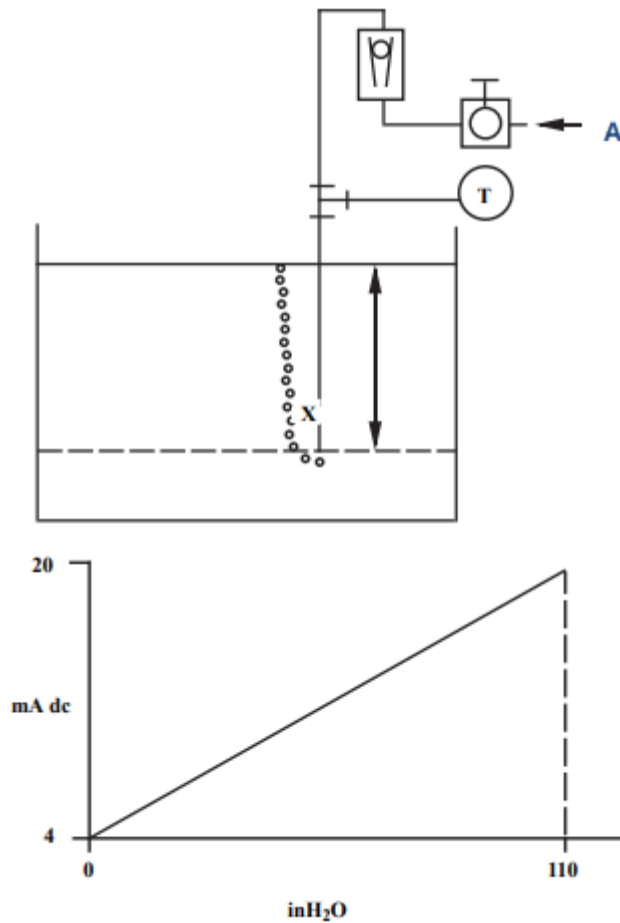
---

### **Bubbler system in open vessel**

You can use a bubbler system that has a top-mounted pressure transmitter in open vessels. This system consists of an air supply, pressure regulator, constant flow meter, pressure transmitter, and a tube that extends down into the vessel.

Bubble air through the tube at a constant flow rate. The pressure required to maintain flow equals the liquid's specific gravity multiplied by the vertical height of the liquid above the tube opening. [Figure 3-22](#) shows a bubbler liquid level measurement example.

Figure 3-22: Bubbler liquid level measurement example



A. Air

Let  $X$  equal the vertical distance between the minimum and maximum measurable levels (100 in.).

Let  $SG$  equal the specific gravity of the fluid (1.1).

Let  $h$  equal the maximum head pressure to be measured in inches of water.

Let Range equal zero to  $h$ .

Then  $h = (X)(SG)$

$= 100 \times 1.1.$

$= 110 \text{ inH}_2\text{O}$

Range = 0 to 110 inH<sub>2</sub>O





## 4 Electrical Installation

### 4.1 Overview

The information in this section covers installation considerations for the Rosemount 2051 Pressure Transmitter with HART® protocol.

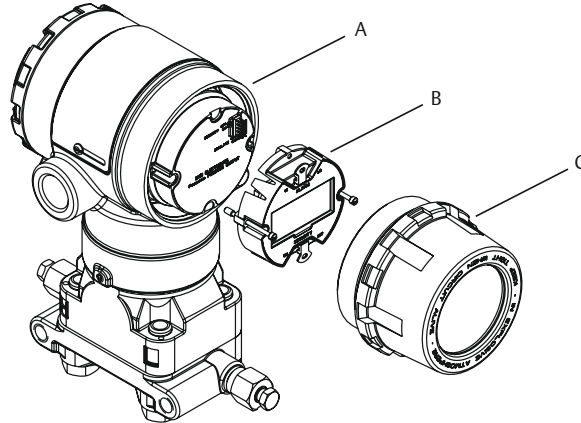
Emerson ships a Quick Start Guide with every transmitter to describe pipe-fitting, wiring procedures, and basic configuration for initial installation.

### 4.2 Local operator interface (LOI)/LCD display

Emerson ships transmitters ordered with the LCD display option (M5) or LOI option (M4) with the display installed.

Carefully align the desired display connector with the electronics board connector. If connectors don't align, the display and electronics board are not compatible.

**Figure 4-1: LCD display**



- A. Jumpers (top and bottom)
- B. LCD display
- C. Extended cover

#### 4.2.1 Rotate local operator interface (LOI)/LCD display

##### Procedure

1. Secure the loop to manual control and remove power to transmitter.
2. Remove transmitter housing cover.
3. Remove screws from the LCD display and rotate to desired orientation.
4. Insert 10-pin connector into the display board for the correct orientation. Carefully align pins for insertion into the output board.
5. Re-insert screws.
6. Reattach transmitter housing cover

### ⚠ WARNING

Emerson recommends tightening the cover until there is no gap between the cover and housing to comply with explosion-proof requirements.

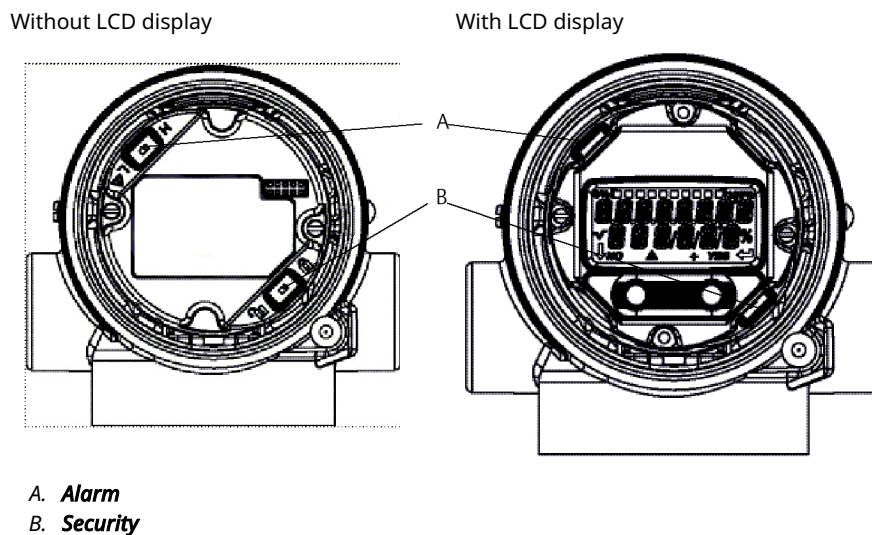
7. Re-attach power and return loop to **automatic** control.

## 4.3 Configuring security and simulation

The Rosemount 2051 has four security methods:

- **Security** switch
- **HART lock**
- **Configuration buttons lock**
- Local operator interface (LOI) password

**Figure 4-2: 4-20 mA electronics board**



### Note

1-5 Vdc **alarm** and **security** switches are located in the same location as 4-20 mA output boards.

### 4.3.1 Set Security switch

Use the **Security** switch to prevent changes to the transmitter configuration data.

If the **Security** switch is set to the locked (🔒) location, the transmitter will reject any transmitter configuration requests sent via HART®, the local operator interface (LOI), or local configuration buttons, and the transmitter configuration data will not be modified. Reference [Figure 4-2](#) for the location of the security switch. To enable the **Security** switch:

#### Procedure

1. Set loop to **Manual** and remove power.
2. Remove transmitter housing cover.
3. Use a small screwdriver to slide the switch to the locked (🔒) position.
4. Replace transmitter housing cover.

#### ⚠ WARNING

Cover must be fully engaged to comply with explosion-proof requirements.

### 4.3.2 HART® Lock

The **HART Lock** prevents changes to the transmitter configuration from all sources; the transmitter will reject all changes requested via HART, the Local Operator Interface (LOI), and local configuration buttons.

You can only set the **HART Lock** via HART communication, and the **HART Lock** is only available in HART Revision 7 mode. Use a communication device or AMS Device Manager to enable or disable the **HART Lock**.

#### Configure HART® Lock using a communication device

##### Procedure

From the **HOME** screen, enter the fast key sequence:

**Fast keys**            2, 2, 6, 4

#### Configure HART Lock using AMS Device Manager

##### Procedure

1. Right-click the device and select **Configure**.
2. Go to **Manual Setup** → **Security**.
3. Select the **Lock/Unlock** button under **HART Lock (Software)** and follow the screen prompts.

### 4.3.3 Configuration Button Lock

The Configuration Button Lock disables all local button functionality.

The transmitter will reject all changes to configuration from the local operator interface (LOI) and local buttons. You can only lock local external keys via HART® communication.

#### Configure Configuration Button Lock using a communication device

##### Procedure

From the **HOME** screen, enter the fast key sequence:

**Fast keys**            2, 2, 6, 3

## Configure Configuration Button Lock using AMS Device Manager

Complete the following steps to disable local button functionality with the Configuration Button Lock.

### Procedure

1. Right-click the device and select **Configure**.
2. Go to **Manual Setup** → **Security**.
3. Select **Disabled** from the **Configuration Buttons** drop-down menu to lock external local keys.
4. Select **Send**.
5. Confirm service reason and select **Yes**.

### 4.3.4 Local operator interface (LOI) password

You can enter and enable an LOI password to prevent review and modification of device configuration via the LOI.

This does not prevent configuration from HART® or external keys (analog **Zero** and **Span**; **Digital Zero Trim**). The LOI password is a 4 digit code that is to be set by the user. If the password is lost or forgotten the master password is "9307".

The LOI password can be configured and enabled/disabled by HART Communication via a communication device, AMS Device Manager, or the LOI.

## Configure password using a communication device

### Procedure

From the **HOME** screen, enter the fast key sequence: 2, 2, 6, 5, 2.

## Configure local operator interface (LOI) password using AMS Device Manager

### Procedure

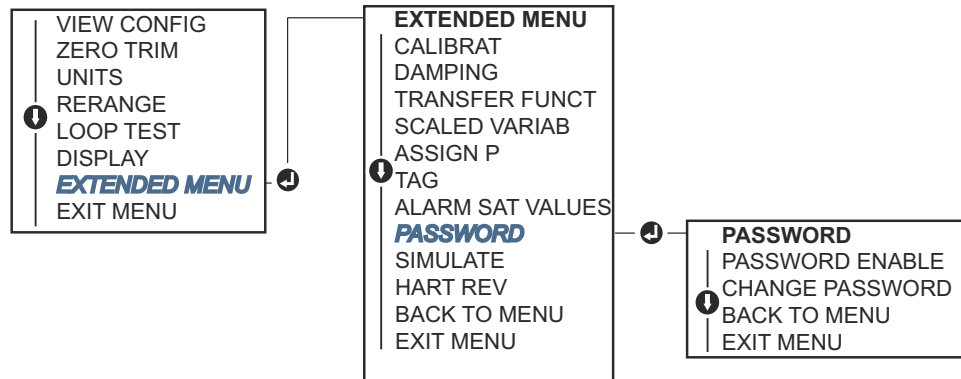
1. Right-click the device and select **Configure**.
2. Go to **Manual Setup** → **Security**.
3. Within the LOI, click the **Configure Password** button and follow the screen prompts.

## Configure local operator interface (LOI) password using LOI

### Procedure

Go to **EXTENDED MENU** → **PASSWORD**.

Figure 4-3: LOI password



## 4.4 Set transmitter alarm

There is an **Alarm** switch on the electronics board.

To change the **Alarm** switch location:

### Procedure

1. Set loop to **Manual** and remove power.
2. Remove transmitter housing cover.
3. Use a small screwdriver to slide switch to desired position.
4. Replace transmitter cover.

### ⚠ WARNING

Fully engage cover to comply with explosion-proof requirements.

## 4.5 Electrical considerations

### ⚠ WARNING

Ensure all electrical installation is in accordance with national and local code requirements.

### Electrical shock

Electrical shock can result in death or serious injury.

Do not run signal wiring in conduit or open trays with power wiring or near heavy electrical equipment.

## 4.5.1 Conduit installation

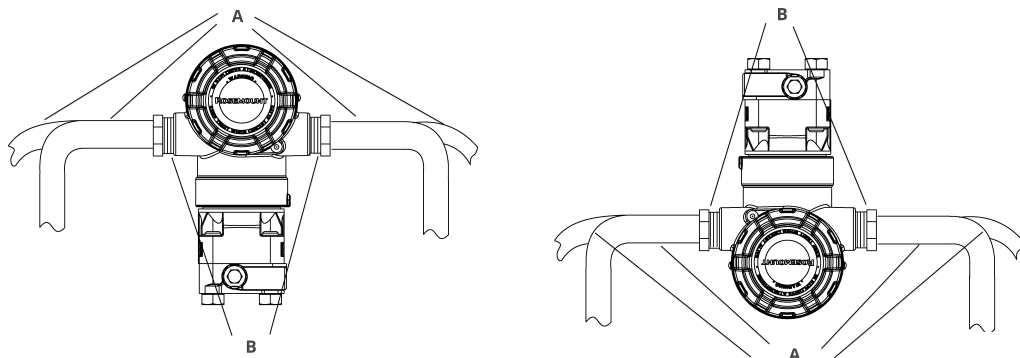
### NOTICE

If all connections are not sealed, excess moisture accumulation can damage the transmitter.

Mount the transmitter with the electrical housing positioned downward for drainage. To avoid moisture accumulation in the housing, install wiring with a drip loop, and ensure the bottom of the drip loop is mounted lower than the conduit connections of the transmitter housing.

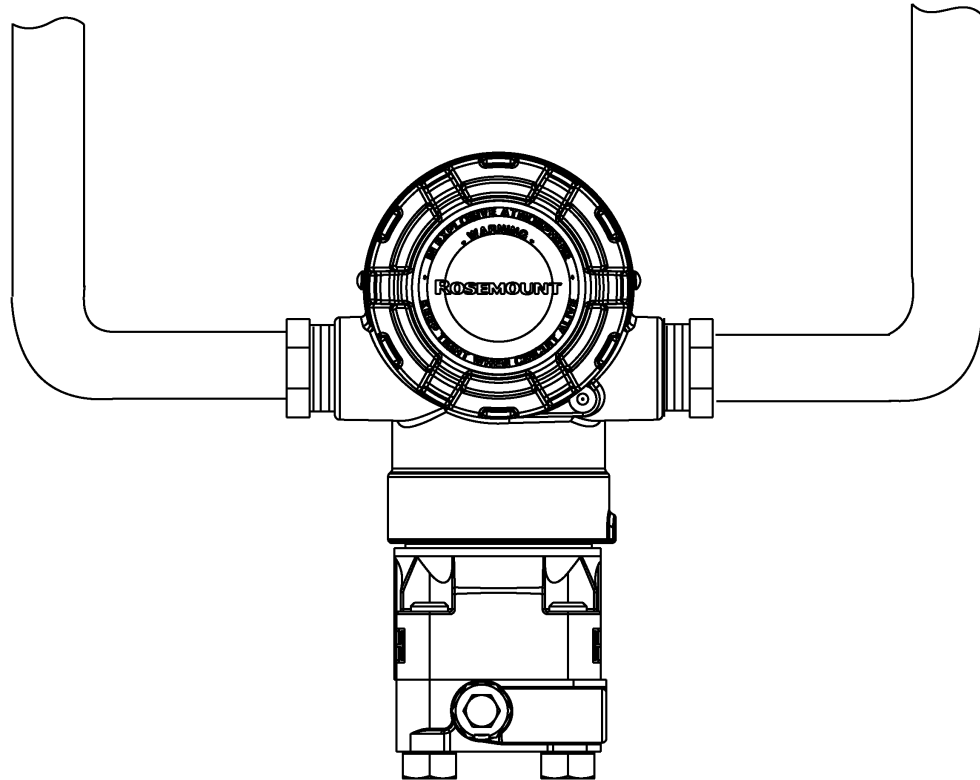
[Figure 4-4](#) shows recommended conduit connections.

**Figure 4-4: Conduit installation diagrams**



- A. Possible conduit line positions
- B. Sealing compound

Figure 4-5: Incorrect conduit installation



## 4.5.2

### Power supply

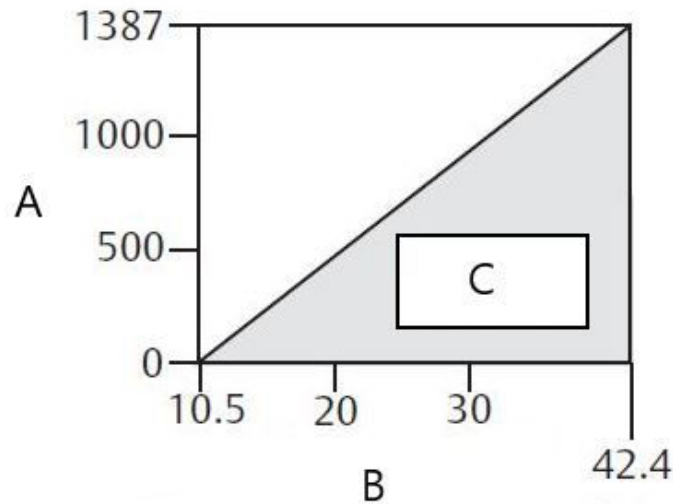
#### 4–20 mA HART® (option code A)

The transmitter operates on 10.5–42.4 Vdc at the terminal of the transmitter. The DC power supply should provide power with less than two percent ripple. A minimum of 16.6 V is required for loops with a 250  $\Omega$  resistance.

#### Note

A minimum loop resistance of 250  $\Omega$  is required to communicate with a communication device. If a single power supply is used to power more than one Rosemount Transmitter, the power supply used, and circuitry common to the transmitters must not have more than 20  $\Omega$  of impedance at 1200 Hz.

**Figure 4-6: Load Limitation**



- A. Load ( $\Omega s$ )
- B. Voltage (VDC)
- C. Operating region

- Maximum loop resistance =  $43.5 \times (\text{power supply voltage} - 10.5)$
- The communication device requires a minimum loop resistance of 250  $\Omega$  for communication.

The total resistance load is the sum of the resistance of the signal leads and the load resistance of the controller, indicator, I.S. Barriers, and related pieces. If intrinsic safety barriers are used, the resistance and voltage drop must be included.

### 1–5 Vdc low power HART® (output code M)

Low power transmitters operate on 9–28 Vdc.

The Dc power supply must provide power with less than 2 percent ripple. The  $V_{\text{out}}$  load must be 100 k $\Omega$  or greater.

## 4.5.3 Wiring the transmitter

### NOTICE

Incorrect wiring can damage the circuit.

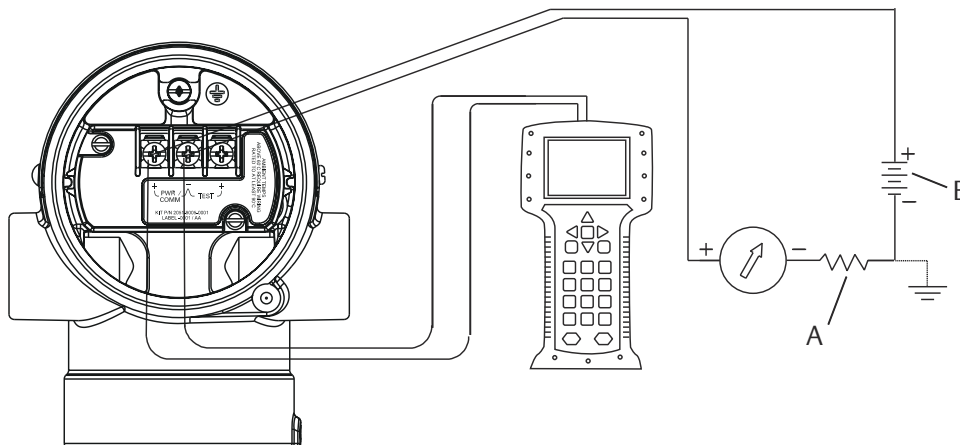
Do not connect the power signal wiring to the test terminals.

#### Note

Use shielded twisted pairs to yield best results. To ensure proper communication, use 24 AWG or larger wire and do not exceed 5000 ft. (1500 m). For 1–5 V 500 ft. (150 m) maximum, Emerson recommends unpaired three conductors or two twisted pairs.

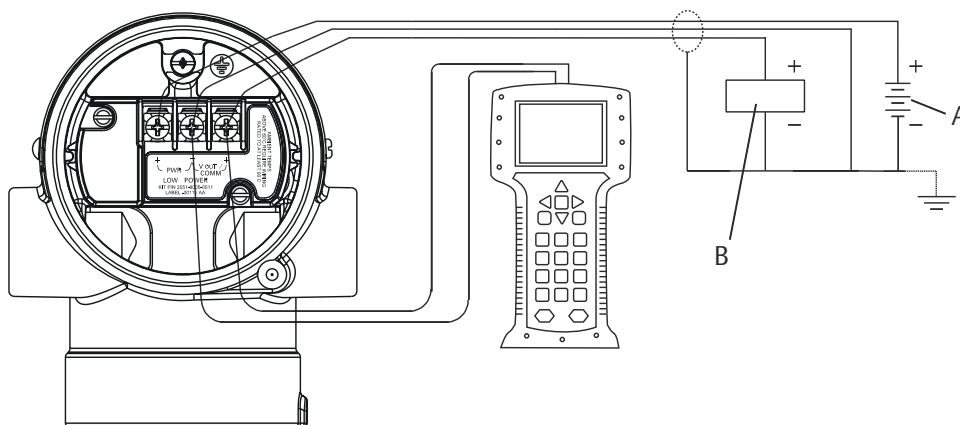


Figure 4-7: Wiring the transmitter (4–20 mA HART®)



- A. Dc power supply
- B.  $R_L \geq 250$  (necessary for HART communication only)

Figure 4-8: Wiring the transmitter (1–5 Vdc low power)



- A. Dc power supply
- B. Voltmeter

To connect wiring:

**Procedure**

1. Remove the housing cover on terminal compartment side. Signal wiring supplies all power to the transmitter.

**⚠ WARNING**

Do not remove the cover in explosive atmospheres when the circuit is live.

2. Connect the leads.

## NOTICE

Power could damage the test diode.

Do not connect the powered signal wiring to the test terminals.

- For 4–20 mA HART output, connect the positive lead to the terminal marked **(pwr/comm+)** and the negative lead to the terminal marked **(pwr/comm-)**.
  - For 1–5 Vdc HART output, connect the positive lead to **(PWR+)** and the negative to the **(PWR-)**.
3. Plug and seal unused conduit connection on the transmitter housing to avoid moisture accumulation in the terminal side.

## 4.5.4 Grounding the transmitter

### Ground signal cable shield

[Figure 4-9](#) summarizes signal cable shield grounding. Trim and insulate the signal cable shield and unused shield drain wire to ensure that the signal cable shield and drain wire do not come in contact with the transmitter case.

To correctly ground the signal cable shield:

#### Procedure

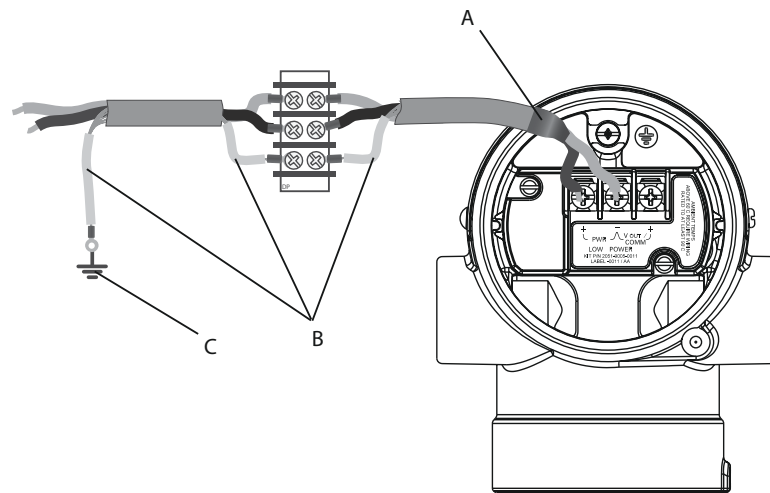
1. Remove the field terminals housing cover.
2. Connect the signal wire pair at the field terminals as indicated in [Figure 4-7](#).
3. At the field terminals, trim the cable shield and shield drain wire closely and insulate them from the transmitter housing.
4. Reattach the field terminals housing cover.

### ⚠ WARNING

Cover must be fully engaged to comply with explosion-proof requirements.

5. At terminations outside the transmitter housing, make sure the cable shield drain wire is continuously connected.
  - a) Prior to the termination point, insulate any exposed shield drain wire as shown in [Figure 4-8](#) (B).
6. Properly terminate the signal cable shield drain wire to an earth ground at or near the power supply.

Figure 4-9: Wiring pair and ground



- A. Insulate shield and shield drain wire
- B. Insulate exposed shield drain wire
- C. Terminate cable shield drain wire to earth ground

#### Related information

[Transmitter case grounding](#)

### Transmitter case grounding

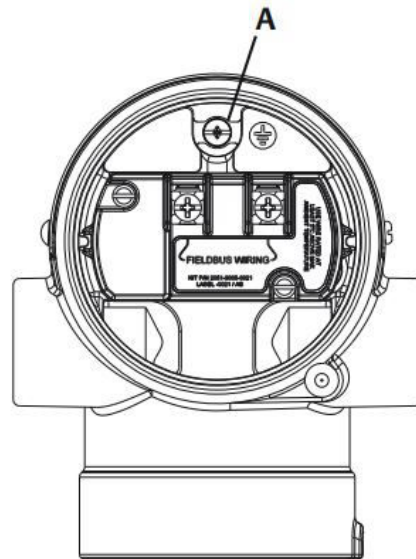
#### ⚠ WARNING

Always ground the transmitter case in accordance with national and local electrical codes.

The most effective transmitter case grounding method is a direct connection to earth ground with minimal impedance. Methods for grounding the transmitter case include:

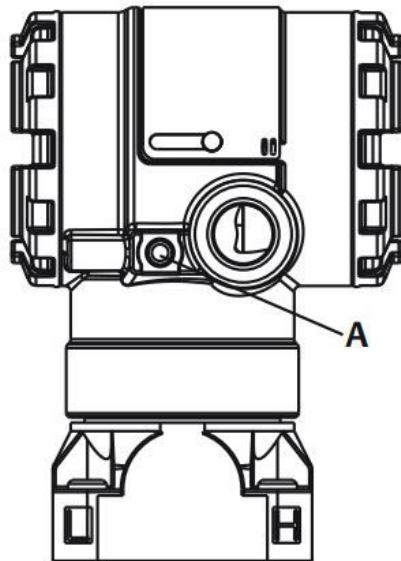
- Internal ground connection: The internal ground connection screw is inside the **FIELD TERMINALS** side of the electronics housing. This screw is identified by a ground symbol (⊕). The ground connection screw is standard on all Rosemount transmitters. Refer to [Figure 4-10](#).
- External ground connection: The external ground connection is located on the exterior of the transmitter housing. Refer to [Figure 4-11](#). This connection is only available with option V5 and T1.

Figure 4-10: Internal Ground Connection



A. Internal ground location

Figure 4-11: External Ground Connection (Option V5 or T1)



A. External ground location

**Note**

Grounding the transmitter case via threaded conduit connection may not provide sufficient ground continuity.

## Transient protection terminal block grounding

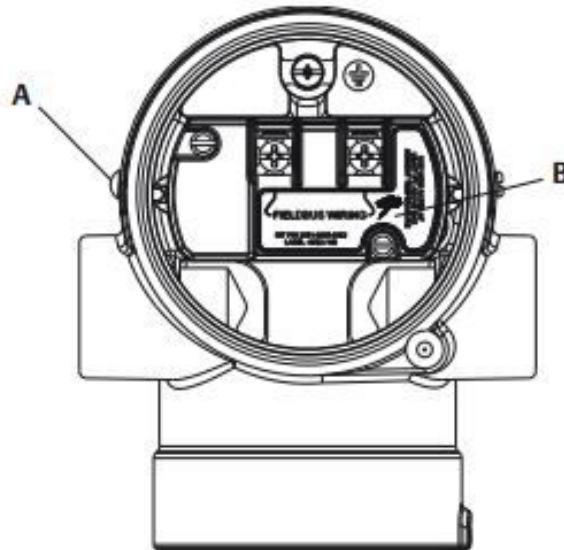
The transmitter can withstand electrical transients of the energy level usually encountered in static discharges or induced switching transients.

### NOTICE

High-energy transients, such as those induced in wiring from nearby lightning strikes, can damage the transmitter.

The transient protection terminal block can be ordered as an installed option (Option Code T1) or as a spare part to retrofit existing transmitters in the field. See Spare Parts in [Rosemount 2051 Pressure Transmitter PDS](#) for part numbers. The lightning bolt symbol shown in [Figure 4-12](#) identifies the transient protection terminal block.

**Figure 4-12: Transient Protection Terminal Block**



- A. External ground connection location
- B. Lightning bolt location

### NOTICE

The transient protection terminal block does not provide transient protection unless the transmitter case is properly grounded. Use the guidelines to ground the transmitter case. Refer to [Figure 4-12](#).



# 5 Operation and maintenance

## 5.1 Overview

This section contains information on operation and maintenance procedures, as well as instructions on configuring with a communication device or AMS Device Manager.

## 5.2 Recommended calibration tasks

### NOTICE

Emerson calibrates absolute pressure transmitters at the factory. Trimming adjusts the position of the factory characterization curve. It is possible to degrade performance of the transmitter if any trim is done improperly or with inaccurate equipment.

### 5.2.1 Calibrate transmitter in the field

#### Procedure

1. Perform sensor zero/lower trim to compensate for mounting pressure effects
2. Set/check basic configuration parameters:
  - a) Output units
  - b) Range points
  - c) Output type
  - d) Damping value

#### Related information

[Install Rosemount 306 Integral Manifold](#)

### 5.2.2 Calibrate on a bench

#### Procedure

1. Perform optional 4-20 mA output trim.
2. Perform a sensor trim.
  - a) Zero/lower trim for using line pressure effect correction.  
Refer to [Integral manifold operation](#) for manifold drain/vent valve operation instructions.
  - b) Perform the optional full scale trim.  
This sets the span of the device and requires accurate calibration equipment.
  - c) Set/check basic configuration parameters.

## 5.3 Calibration overview

Emerson fully calibrates the pressure transmitter at the factory. You can also calibrate in the field to meet plant requirements or industry standards.

Complete calibration of the transmitter can be split into two tasks:

- Sensor calibration
- Analog output calibration

Sensor calibration allows you to adjust the pressure (digital value) reported by the transmitter to be equal to a pressure standard. The sensor calibration can adjust the pressure offset to correct for mounting conditions or line pressure effects. Emerson recommends the correction. The calibration of the pressure range (pressure span or gain correction) requires accurate pressure standards (sources) to provide a full calibration.

Like the sensor calibration, you can calibrate the analog output to match the user measurement system. The analog output trim (4–20 mA/ 1–5 V output trim) will calibrate the loop at the 4 mA (1 V) and 20 mA (5 V) points.

The sensor calibration and the analog output calibration combine to match the transmitter's measurement system to the plant standard.

### 5.3.1 Calibrating the sensor

- **Sensor trim:** [Performing a sensor trim](#)
- **Zero trim:** [Perform a digital zero trim \(option DZ\)](#)

#### Related information

[Performing a sensor trim](#)

[Perform a digital zero trim \(option DZ\)](#)

### 5.3.2 Calibrating the 4–20 mA output

- 4–20 mA/1–5V Output trim: [Performing digital-to-analog trim \(4–20 mA/1–5 V output trim\)](#)
- 4–20 mA/1–5V Output trim using other scale: [Performing digital-to-analog trim \(4–20 mA/1–5 V output trim\) using other scale](#)

#### Related information

[Performing digital-to-analog trim \(4–20 mA/1–5 V output trim\)](#)

[Performing digital-to-analog trim \(4–20 mA/1–5 V output trim\) using other scale](#)

### 5.3.3 Determine necessary sensor trims

Bench calibrations allow for calibrating the instrument for its desired range of operation.

Straightforward connections to pressure source allow for a full calibration at the planned operating points. Exercising the transmitter over the desired pressure range allows for verification of the analog output.

#### NOTICE

It is possible to degrade the performance of the transmitter if a trim is done improperly or with inaccurate equipment.



For transmitters that are field installed, the manifolds allow the differential transmitter to be zeroed using the zero trim function. This field calibration will eliminate any pressure offsets caused by mounting effects (head effect of the oil fill) and static pressure effects of the process.

To determine the necessary trims:

#### Procedure

1. Apply pressure.
2. Check digital pressure; if the digital pressure does not match the applied pressure, perform a digital trim.
3. Check reported analog output against the live analog output. If they do not match, perform an analog output trim.

#### Related information

[Trimming the pressure signal](#)

[Recall Factory Trim - Sensor Trim](#)

[Performing digital-to-analog trim \(4–20 mA/1–5 V output trim\)](#)

[Performing a sensor trim](#)

[Rosemount 304, 305, and 306 Manifolds](#)

### 5.3.4 Trimming using configuration buttons

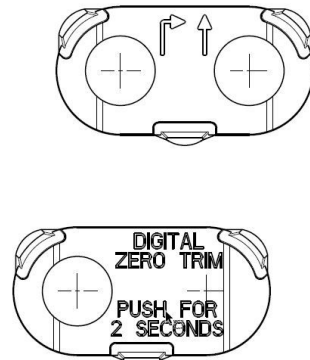
Local configuration buttons are external buttons located underneath the top tag of the transmitter. There are two possible sets of local configuration buttons that can be ordered with the transmitter and used to perform trim operations: **Digital Zero Trim** and **LOI** (Local Operator Interface).

#### Procedure

1. To access the buttons, loosen screw and rotate top tag until buttons are visible.
2. Use the appropriate button:
  - LOI (M4): Can perform both digital sensor trim and the 4–20 mA output trim (analog output trim).
  - Digital zero trim (DZ): Used for performing a sensor zero trim.
3. Monitor all configuration changes by a display or by measuring the loop output.

[Figure 5-1](#) shows the physical differences between the two sets of buttons.

Figure 5-1: Local configuration button options



#### Related information

[Performing a sensor trim](#)

[Trimming the analog output](#)

[Determine calibration frequency](#)

## 5.4 Determine calibration frequency

Calibration frequency can vary greatly depending on the application, performance requirements, and process conditions. See [How to Calculate Pressure Transmitter Calibration Intervals Technical Note](#).

To determine the calibration frequency that meets the needs of your application:

#### Procedure

1. Determine the performance required for your application.
2. Determine the operating conditions.
3. Calculate the Total Probable Error (TPE).
4. Calculate the stability per month.
5. Calculate the calibration frequency.

### 5.4.1 Determine calibration frequency for Rosemount 2051 (example)

#### Procedure

1. Determine the performance required for your application.

**Required performance**            0.30% of span

2. Determine the operating conditions.

**Transmitter**                            Rosemount 2051CD, Range 2 [upper range limit (URL)=250 inH<sub>2</sub>O(623 mbar)]

**Calibrated span**                        150 inH<sub>2</sub>O (374 mbar)

**Ambient temperature change** ± 50 °F (28 °C)

**Line pressure** 500 psig (34.5 bar)

- Calculate total probable error (TPE).

$$\text{TPE} = \frac{\sqrt{(\text{ReferenceAccuracy})^2 + (\text{TemperatureEffect})^2 + (\text{StaticPressureEffect})^2}}{\text{span}} = 0.189\% \text{ of span}$$

Where:

**Reference accuracy** ± 0.065% of span

**Ambient temperature effect**  $\left(\frac{0.025 \times \text{URL}}{\text{Span}} + 0.125\right)\% \text{ per } 50 \text{ }^\circ\text{F} = \pm 0.167\% \text{ of span}$

**Span static pressure effect** 0.1% reading per 1000 psi (69 bar) = ±0.05% of span at maximum span

---

**Note**

Zero static pressure effect removed by zero trimming at line pressure.

---

- Calculate the stability per month.

$$\text{Stability} = \pm \left[ \frac{0.100 \times \text{URL}}{\text{Span}} \right] \% \text{ of span for 2 years} = \pm 0.0069\% \text{ of URL for 1 month}$$

- Calculate calibration frequency.

$$\text{Cal. Freq.} = \frac{(\text{Req. Performance} - \text{TPE})}{\text{Stability per Month}} = \frac{0.3\% - 0.189\%}{0.0069\%} = 16 \text{ months}$$

## 5.4.2 Determine calibration frequency for Rosemount 2051C with P8 option (0.05% accuracy & five-year stability)

### Procedure

- Determine the performance required for your application.

**Required performance** 0.30% of span

- Determine the operating conditions.

**Transmitter** 2051CD, Range 2 [upper range limit (URL)=250 inH<sub>2</sub>O(623 mbar)]

**Calibrated span** 150 inH<sub>2</sub>O (374 mbar)

**Ambient temperature change** ± 50 °F (28 °C)

**Line pressure** 500 psi (34.5 bar)

3. Calculate total probable error (TPE).

$$\text{TPE} = \sqrt{(\text{ReferenceAccuracy})^2 + (\text{TemperatureEffect})^2 + (\text{StaticPressureEffect})^2} = 0.117\% \text{ of span}$$

Where:

**Reference accuracy** ± 0.05% of span

$$\pm \left( \frac{0.025 \times \text{URL}}{\text{Span}} + 0.125 \right) \text{ per } 50 \text{ }^\circ\text{F} = \pm 0.0833\% \text{ of span}$$

**Ambie temperature effect**

**Span static pressure effect** 0.1% reading per 1000 psi (69 bar) = ±0.05% of span at maximum span

---

**Note**

Zero static pressure effect removed by zero trimming at line pressure.

---

4. Calculate the stability per month.

$$\text{Stability} = \pm \left[ \frac{0.125 \times \text{URL}}{\text{Span}} \right] \% \text{ of span for 5 years} = \pm 0.0035\% \text{ of span per month}$$

5. Calculate calibration frequency.

$$\text{Cal. Freq.} = \frac{(\text{Req. Performance} - \text{TPE})}{\text{Stability per Month}} = \frac{(0.3\% - 0.117\%)}{0.0035\%} = 52 \text{ months}$$

## 5.5 Compensating for span line pressure effects (Range 4 and 5)

Rosemount 2051 Range 4 and 5 Pressure Transmitters require a special calibration procedure when used in differential pressure applications. The purpose of this procedure is to optimize transmitter performance by reducing the effect of static line pressure in these applications.

The Rosemount Differential Pressure Transmitters (Ranges 1 through 3) do not require this procedure because optimization occurs at the sensor.

The systematic span shift caused by the application of static line pressure is -0.95 percent of reading per 1000 psi (69 bar) for Range 4 transmitters and -1 percent of reading per 1000 psi (69 bar) for Range 5 transmitters.

**Related information**

[Compensate for span line pressure effect \(example\)](#)

## 5.5.1 Compensate for span line pressure effect (example)

To correct for systematic error caused by high static line pressure, first use the following formulas to determine the corrected values for the high trim value.

### High trim value

$$HT = (URV - [S/100 \times P/1000 \times LRV])$$

Where:

<b>HT</b>	Corrected high trim value
<b>URV</b>	Upper range value
<b>S</b>	Span shift per specification (as percent of reading)
<b>P</b>	Static line pressure in psi.

In this example:

<b>URV</b>	1500 inH <sub>2</sub> O (3.7 bar)
<b>S</b>	-0.95%
<b>P</b>	1200 psi
<b>LT</b>	1500 inH <sub>2</sub> O + (0.95%/100 x 1200 psi/100 psi x 1500 inH <sub>2</sub> O)
<b>LT</b>	1517.1 inH <sub>2</sub> O

Complete the upper sensor trim procedure as described in [Trimming the pressure signal](#). However, enter the calculated correct upper sensor trim value of 1517.1 inH<sub>2</sub>O with a communication device.

### Related information

[Trimming the pressure signal](#)

## 5.6 Trimming the pressure signal

### 5.6.1 Sensor trim overview

A sensor trim corrects the pressure offset and pressure range to match a pressure standard.

The upper sensor trim corrects the pressure range, and the lower sensor trim (zero trim) corrects the pressure offset. An accurate pressure standard is required for full calibration. You can perform a zero trim if the process is vented or the high and low side pressure are equal (for differential pressure transmitters).

Zero trim is a single-point offset adjustment. It is useful for compensating for mounting position effects and is most effective when performed with the transmitter installed in its final mounting position. Since this correction maintains the slope of the characterization curve, it should not be used in place of a sensor trim over the full sensor range.

When performing a zero trim, ensure the equalizing valve is open and all wet legs are filled to the correct levels. Apply line pressure to the transmitter during a zero trim to eliminate line pressure errors.

---

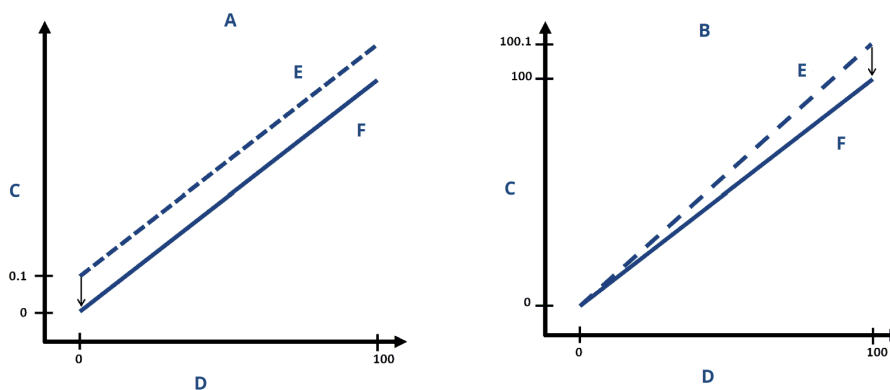
### Note

Do not perform a **zero trim** on Rosemount Absolute Pressure Transmitters. **Zero trim** is zero-based, and absolute pressure transmitters reference absolute zero. To correct

mounting position effects on an absolute pressure transmitter, perform a **low trim** within the sensor trim function. The **low trim** function provides an offset correction similar to the zero trim function, but it does not require zero-based input.

**Upper** and **lower** sensor trim is a two-point sensor calibration where two end-point pressures are applied and all output is linearized between them; these trims require an accurate pressure source. Always adjust the low trim value first to establish the correct offset. Adjustment of the high trim value provides a slope correction to the characterization curve based on the low trim value. The trim values help optimize performance over a specific measurement range.

**Figure 5-2: Sensor trim example**



- A. Zero/lower sensor trim
- B. Upper sensor trim
- C. Pressure reading
- D. Pressure input
- E. Before trim
- F. After trim

**Related information**

[Integral manifold operation](#)

## 5.6.2 Performing a sensor trim

When performing a sensor trim, you can trim both the upper and lower limits.

If performing both upper and lower trims, the lower trim must be done prior to the upper time.

**Note**

Before entering any values, use a pressure input source that is at least four times more accurate than the transmitter and allow the input pressure to stabilize for 10 seconds.

### Perform a sensor trim with a communication device

**Procedure**

1. From the **HOME** screen, enter the fast key sequence and follow the steps within the communication device to complete the sensor trim.

**Fast keys**      3, 4, 1

2. Select **2: Lower Sensor Trim**.

**Note**

Select pressure points so that lower and upper values are equal to or outside the expected process operation range.

3. Follow the commands provided by the communication device to complete the adjustment of the lower value.
4. Select **3: Upper Sensor Trim**.
5. Follow the commands provided by the communication device to complete the adjustment of the upper value.

**Related information**

[Reranging the transmitter](#)

## Perform a sensor trim using AMS Device Manager

**Procedure**

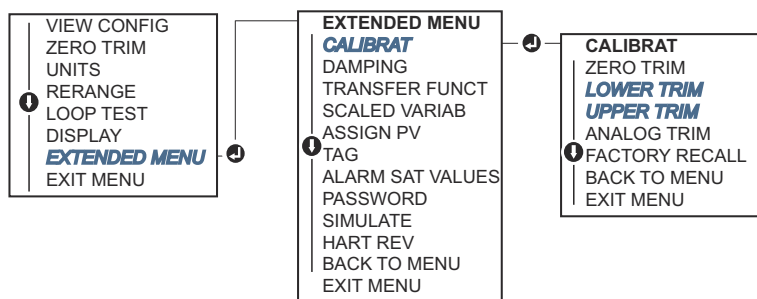
1. Right-click the device and go to **Method** → **Calibrate** → **Sensor Trim** → **Lower Sensor Trim**.
2. Follow the screen prompts to perform a sensor trim using AMS Device Manager.
3. If desired, right-click the device again and go to **Method** → **Calibrate** → **Sensor Trim** → **Upper Sensor Trim**

## Perform a sensor trim using a local operator interface (LOI)

**Procedure**

Perform an upper and lower sensor trim by referencing [Figure 5-3](#).

**Figure 5-3: Sensor trim using LOI**



## Perform a digital zero trim (option DZ)

A digital **zero trim** (option **DZ**) provides the same function as a zero/lower sensor trim. However, you can use this option in hazardous areas at any given time by pushing the **Zero Trim** button when the transmitter is at zero pressure.

If the transmitter is not close enough to zero when the button is pushed, the command may fail due to excess correction. If you order the transmitter with external configuration buttons, you can use them to perform a digital zero trim. See [Figure 5-1](#) for **DZ** button location.

**Procedure**

1. Loosen the top tag of the transmitter to expose buttons.

2. Press and hold the **Digital Zero** button for at least two seconds and then release to perform a digital zero trim.

### 5.6.3 Recall Factory Trim - Sensor Trim

The `Recall Factory Trim - Sensor Trim` command allows the restoration of the as-shipped factory settings of the sensor trim.

This command can be useful for recovering from an inadvertent zero trim of an absolute pressure unit or inaccurate pressure source.

#### Recall factory trim using a communication device

##### Procedure

1. From the **HOME** screen, enter the fast key sequence: 3, 4, 3.
2. Follow the steps within the communication device to complete the sensor trim.

#### Recall factory trim using AMS Device Manager

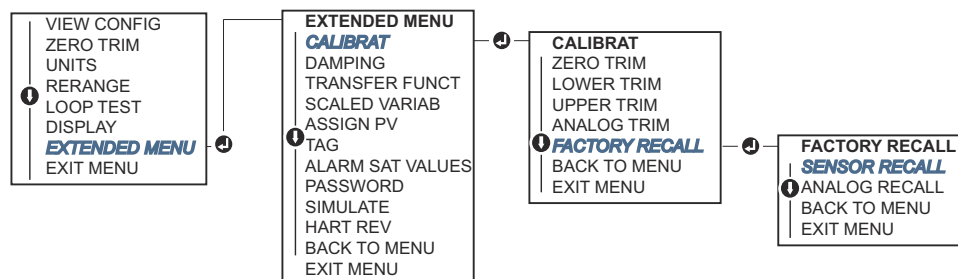
##### Procedure

1. Right-click the device and go to **Method** → **Calibrate** → **Restore Factory Calibration**.
2. Set the control loop to **Manual**.
3. Select **Next**.
4. Select **Sensor Trim** under **Trim to recall** and click **Next**.
5. Follow the screen prompts to recall sensor trim.

#### Recall factory trim using a local operator interface (LOI)

Refer to [Figure 5-4](#) to recall factory sensor trim.

Figure 5-4: Recall factory trim using LOI



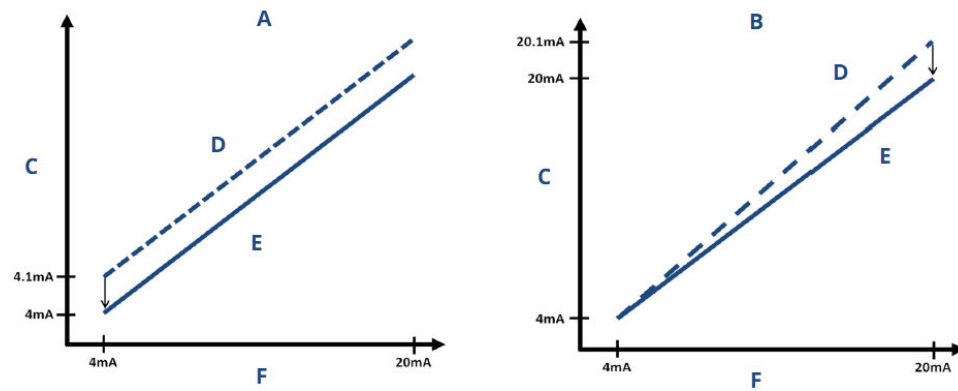
## 5.7 Trimming the analog output

You can use the `Analog Output Trim` command to adjust the transmitter's current output at the 4 and 20 mA (1 – 5 Vdc) points to match the plant standards.

Perform this trim after the digital to analog conversion so only the 4–20 mA analog (1– 5 Vdc) signal will be affected. [Figure 5-5](#) graphically shows the two ways the characterization curve is affected when an analog output trim is performed.



Figure 5-5: Analog output trim example



- A. 4-20 mA output trim - zero/lower trim
- B. 4-20 mA output trim - upper trim
- C. Meter reading
- D. Before trim
- E. After trim
- F. mA output

### 5.7.1

## Performing digital-to-analog trim (4–20 mA/1–5 V output trim)

### Note

If a resistor is added to the loop, ensure that the power supply is sufficient to power the transmitter to a 20 mA output with additional loop resistance.

### Perform a 4–20 mA/1–5 V output trim using a communication device

#### Procedure

1. From the **HOME** screen, enter the fast key sequence: 3, 4, 2, 1.
2. Follow the steps within the communication device to complete the 4-20 mA output trim.

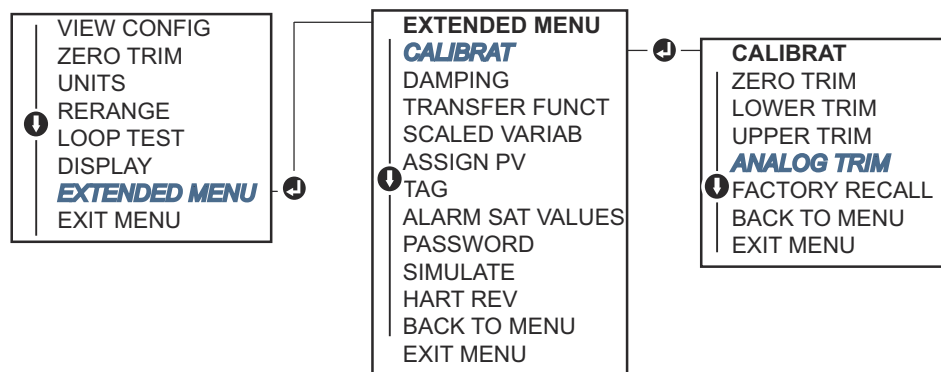
### Perform a 4–20 mA/1–5 V output trim using AMS Device Manager

#### Procedure

1. Right-click the device and go to **Method** → **Calibrate** → **Analog Calibration**.
2. Select **Digital to Analog Trim**.
3. Follow the screen prompts to perform a 4–20 mA output trim.

## Perform 4–20 mA/1–5 V output trim using a local operator interface (LOI)

Figure 5-6: 4–20 mA output trim using LOI



### 5.7.2 Performing digital-to-analog trim (4–20 mA/1–5 V output trim) using other scale

The scaled 4–20 mA output Trim command matches the 4 and 20 mA points to a user-selectable reference scale other than 4 and 20 mA, such as 2 to 10 volts if measuring across a 500 Ω load or 0 to 100 percent if measuring from a distributed control system (DCS).

To perform a scaled 4–20 mA output trim, connect an accurate reference meter to the transmitter and trim the output signal to scale, as outlined in the output trim procedure.

#### Perform a 4–20/1–5 V mA output trim using other scale using a communication device

##### Procedure

1. From the **HOME** screen, enter the fast key sequence: 3, 4, 2, 2.
2. Follow the steps within the communication device to complete the 4-20 mA output trim using other scale.

#### Perform a 4–20 mA/ 1–5 V output trim using other scale using AMS Device Manager

##### Procedure

1. Right-click the device and go to **Method** → **Calibrate** → **Analog Calibration**.
2. Select **Scaled Digital to Analog Trim**.
3. Follow screen prompts to perform a 4–20 mA/ 1–5 V output trim.

### 5.7.3 Recalling factory trim - analog output

You can use the Recall Factory Trim - Analog Output command to restore the as-shipped factory settings to the analog output trim.

This command can be useful for recovering from an inadvertent trim, incorrect plant standard, or faulty meter.

## Recall factory trim - analog output using a communication device

### Procedure

1. From the **HOME** screen, enter the fast key sequence: 3, 4, 3.
2. Follow the steps within the communication device to complete the digital to analog trim using other scale.

## Recall factory trim - analog output using AMS Device Manager

### Procedure

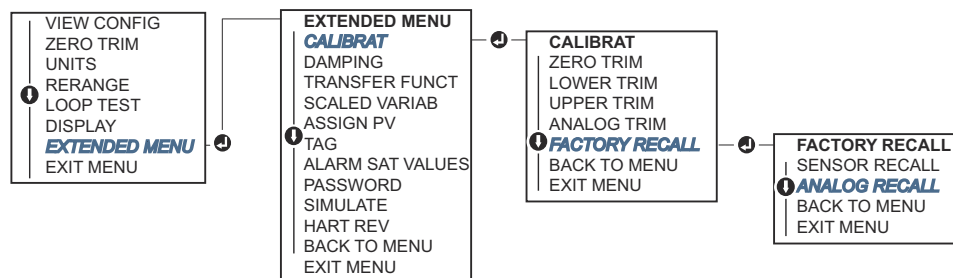
1. Right-click the device and go to **Method** → **Calibrate** → **Restore Factory Calibration**.
2. Select **Next** to set the control loop to **manual**.
3. Select **Analog Output Trim** under **Select trim to recall** and click **Next**.
4. Follow screen prompts to recall analog output trim.

## Recall factory trim - analog output using a Local Operator Interface (LOI)

### Procedure

See [Figure 5-7](#) for LOI instructions.

**Figure 5-7: Recall factory trim – analog output using LOI**



## 5.8 Switching HART® revision

Some systems are not capable of communicating with HART Revision 7 devices.

The following procedures list how to change HART revisions between HART Revision 7 and HART Revision 5.

### 5.8.1 Switch HART® revision using generic menu

If the HART configuration tool is not capable of communicating with a HART Revision 7 device, it should load a generic menu with limited capability. The following procedure explains how to switch between HART Revision 7 and HART Revision 5 from a generic menu.

#### Procedure

1. Locate **Message** field.
2. To change to HART Revision 5, enter `HART5` in the **Message** field.
3. To change to HART Revision 7, enter `HART7` in the **Message** field.

## 5.8.2 Switch HART® revision using a communication device

### Procedure

1. From the **HOME** screen, enter the fast key sequence:  
**HART 5**            2, 2, 5, 2, 4  
**HART 7**            2, 2, 5, 2, 3
2. Follow steps within the communication device to complete the HART revision change.

## 5.8.3 Switch HART® revision using AMS Device Manager

### Procedure

1. Go to **Manual Setup** → **HART**.
2. Select **Change HART Revision** and then follow the screen prompts.

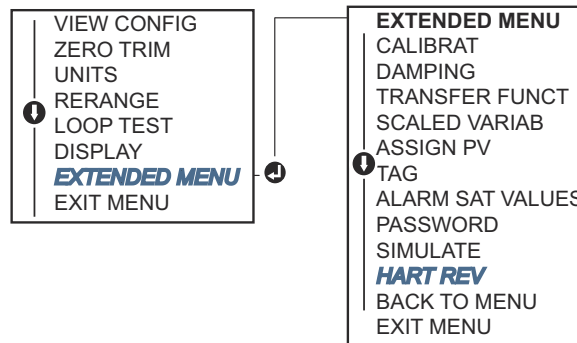
### Note

AMS Device Manager versions 10.5 or greater are compatible with HART Revision 7.

## 5.8.4 Switch HART® revision using a local operator interface (LOI)

Use [Figure 5-8](#) to change HART revision:

**Figure 5-8: Change HART revision using LOI**



### Procedure

1. Go to **EXTENDED MENU** → **HART REV**.
2. Select **HART REV 5** or **HART Rev 7**.

# 6 Troubleshooting

## 6.1 Overview

The following sections provide summarized maintenance and troubleshooting suggestions for the most common operating problems.

## 6.2 Troubleshooting for 4-20 mA output

### 6.2.1 Transmitter milliamp reading is zero

#### Recommended actions

1. Verify terminal voltage is 10.5 to 42.4 Vdc at signal terminals.
2. Check power wires for reversed polarity.
3. Check that power wires are connected to signal terminals.
4. Check for open diode across test terminal.

### 6.2.2 Transmitter not communicating with communication device

#### Recommended actions

1. Verify terminal voltage is 10.5 to 42.2 Vdc.
2. Check loop resistance.

---

#### Note

(Power supply voltage - terminal voltage)/loop current must be 250  $\Omega$  minimum.

---

3. Check that power wires are connected to signal terminals and not test terminals.
4. Verify clean DC power to transmitter.

---

#### Note

Maximum AC noise is 0.2 volts peak to peak.

---

5. Verify the output is between 4 and 20 mA or saturation levels.
6. Use the communication device to poll for all addresses.

### 6.2.3 Transmitter milliamp reading is low or high

#### Recommended actions

1. Verify applied pressure.
2. Verify 4 and 20 mA range points.
3. Verify **output** is not in **alarm** condition.
4. Perform **analog trim**.
5. Check that power wires are connected to the correct signal terminals (positive to positive, negative to negative) and not the test terminal.

## 6.2.4 Transmitter will not respond to changes in applied pressure

### Recommended actions

1. Check impulse piping or manifold for blockage.
2. Verify applied pressure is between 4 and 20 mA points.
3. Verify the **output** is not in **Alarm** condition.
4. Verify transmitter is not in **Loop Test** mode.
5. Verify transmitter is not in **Multidrop** mode.
6. Check test equipment.

## 6.2.5 Digital pressure variable reading is low or high

### Recommended actions

1. Check impulse piping for blockage or low fill in wet leg.
2. Verify transmitter is calibrated properly.
3. Check test equipment (verify accuracy).
4. Verify pressure calculations for application.

## 6.2.6 Digital pressure variable reading is erratic

### Recommended actions

1. Check application for faulty equipment in pressure line.
2. Verify transmitter is not reacting directly to equipment turning On/Off.
3. Verify damping is set properly for application.

## 6.2.7 Milliamps reading is erratic

### Recommended actions

1. Verify power source to transmitter has adequate voltage and current.
2. Check for external electrical interference.
3. Verify transmitter is properly grounded.
4. Verify shield for twisted pair is only grounded at one end.

## 6.3 Troubleshooting for 1-5 Vdc output

### 6.3.1 Transmitter voltage reading is zero

#### Recommended actions

1. Verify terminal voltage is 5.8 to 28.0 Vdc at signal terminals.
2. Check power wires for reversed polarity.
3. Check that power wires are connected to signal terminals.
4. Check for open diode across test terminal.

## 6.3.2 Transmitter not communicating with communication device

### Recommended actions

1. Verify terminal voltage is 5.8 to 28.0 Vdc.
2. Check loop resistance.  
(Power supply voltage - transmitter voltage)/loop current should be 250  $\Omega$  minimum.
3. Check that power wires are connected to signal terminals and not test terminals.
4. Verify clean DC power to transmitter.  
Maximum AC noise is 0.2 volts peak to peak.
5. Verify the is output between 1-5 Vdc or saturation levels.
6. Use communication device to poll for all addresses.

## 6.3.3 Transmitter voltage reading is low or high

### Recommended actions

1. Verify applied pressure.
2. Verify 1-5 Vdc range points.
3. Verify output is not in `Alarm` condition.
4. Perform analog trim.
5. Check that the power wires are connected to the correct signal terminals (positive to positive, negative to negative) and not the test terminal.

## 6.3.4 Transmitter will not respond to changes in applied pressure

### Recommended actions

1. Check impulse piping or manifold for blockage.
2. Verify applied pressure is between the 1-5 Vdc points.
3. Verify the output is not in `Alarm` condition.
4. Verify transmitter is not in `Loop Test` mode.
5. Verify transmitter is not in `Multidrop` mode.
6. Check test equipment.

## 6.3.5 Digital pressure variable reading is low or high

### Recommended actions

1. Check impulse piping for blockage or low fill in wet leg.
2. Verify transmitter is calibrated properly.
3. Check test equipment (verify accuracy).
4. Verify pressure calculations for application.

## 6.3.6 Digital pressure variable reading is erratic

### Recommended actions

1. Check application for faulty equipment in pressure line.
2. Verify transmitter is not reacting directly to equipment turning On/Off.
3. Verify damping is set properly for application.

## 6.3.7 Voltage reading is erratic

### Recommended actions

1. Verify power source to transmitter has adequate voltage and current.
2. Check for external electrical reference.
3. Verify transmitter is properly grounded.
4. Verify shield for twisted pair is only grounded at one end.

## 6.4 Diagnostic messages

Listed in the below sections are detailed descriptions of the possible messages that will appear on either the LCD/local operator interface (LOI) display, a communication device, or an AMS Device Manager system.

Possible statuses are:

- **Good**
- **Failed – fix now**
- **Maintenance – fix soon**
- **Advisory**

### 6.4.1 Status: Failed - fix now

#### No Pressure Updates

There are no pressure updates from the sensor to the electronics.

<b>LCD display</b>	<b>NO P UPDATE</b>
<b>Local Operator Interface (LOI)</b>	<b>NO PRESS UPDATE</b>

### Recommended actions

1. Ensure the sensor cable connection to the electronics is tight.
2. Replace the transmitter.

#### Electronics Board Failure

A failure has been detected in the electronics circuit board.

<b>LCD display</b>	<b>FAIL BOARD</b>
<b>Local Operator Interface (LOI)</b>	<b>FAIL BOARD</b>



#### Recommended action

Replace the pressure transmitter.

### Critical Sensor Data Error

LCD display screen      **MEMRY ERROR**

Local Operator Interface (LOI) screen      **MEMORY ERROR**

A user-written parameter does not match the expected value.

#### Recommended actions

1. Confirm and correct all parameters listed in **Device Information**.
2. Perform a device reset.
3. Replace pressure transmitter.

### Critical Electronics Data Error

LCD display screen      **MEMRY ERROR**

Local Operator Interface (LOI) screen      **MEMORY ERROR**

A user-written parameter does not match the expected value.

#### Recommended actions

1. Confirm and correct all parameters listed in **Device Information**.
2. Perform a device reset.
3. Replace pressure transmitter.

### Sensor Failure

LCD display screen      FAIL SENSOR

Local operator interface (LOI) screen      FAIL SENSOR

A failure has been detected in the pressure sensor.

#### Recommended action

Replace pressure transmitter.

### Incompatible Electronics and Sensor

LCD display screen      XMTR MSMTCH

Local operator interface (LOI) screen      XMTR MSMTCH

The pressure sensor is incompatible with the attached electronics.

**Recommended action**

Replace the pressure transmitter.

## 6.4.2 Status: Maintenance - fix soon

### No Temperature Updates

There are no temperature updates from the sensor to the electronics.

<b>LCD display</b>	<b>NO T UPDATE</b>
<b>Local Operator Interface (LOI)</b>	<b>NO TEMP UPDATE</b>

**Recommended actions**

1. Ensure the sensor cable connection to the electronics is tight.
2. Replace the pressure transmitter.

### Pressure Out of Limits

<b>LCD display screen</b>	<b>PRES LIMITS</b>
<b>Local operator interface (LOI) screen</b>	<b>PRES OUT LIMITS</b>

The pressure is either above or below the sensor limits.

**Recommended actions**

1. Check the transmitter pressure connection to ensure it is not plugged and that the isolating diaphragms are not damaged.
2. Replace the pressure transmitter.

### Sensor Temperature Beyond Limits

<b>LCD display screen</b>	<b>TEMP LIMITS</b>
<b>Local Operator Interface (LOI) screen</b>	<b>TEMP OUT LIMITS</b>

The sensor temperature has exceeded its safe operating range.

**Recommended actions**

1. Check the process and ambient conditions are within -85 to 194 °F (-65 to 90 °C).
2. Replace the pressure transmitter.

### Electronics Temperature Beyond Limits

<b>LCD display screen</b>	<b>TEMP LIMITS</b>
<b>Local operator interface (LOI) screen</b>	<b>TEMP OUT LIMITS</b>

The electronics temperature has exceeded its safe operating range.

**Recommended actions**

1. Confirm electronics temperature is within limits of -85 to +194 °F (-65 to +90 °C).
2. Replace the pressure transmitter.

### Electronics Board Parameter Error

LCD display screen      **MEMRY WARN** (also in advisory)

Local Operator Interface (LOI) screen      **MEMORY WARN** (also in advisory)

A device parameter does not match the expected value. The error does not affect transmitter operation or analog output.

**Recommended action**

Replace the pressure transmitter.

### Configuration Buttons Operator Error

LCD display screen      **STUCK BUTTON**

Local Operator Interface (LOI) screen      **STUCK BUTTON**

Device is not responding to button presses.

**Recommended actions**

1. Check configuration buttons are not stuck.
2. Replace the pressure transmitter.

## 6.4.3 Status: Advisory

### Non-Critical User Data Warning

LCD display screen      **MEMRY WARN**

Local Operator Interface (LOI) screen      **MEMORY WARN**

A user-written parameter does not match expected value.

**Recommended actions**

1. Confirm and correct all parameters listed in **Device Information**.
2. Perform a device reset.
3. Replace the pressure transmitter.

## Sensor Parameter Warning

LCD display screen	MEMRY WARN
Local Operator Interface (LOI) screen	MEMORY WARN

A user-written parameter does not match expected value.

### Recommended actions

1. Confirm and correct all parameters listed in **Device Information**.
2. Perform a device reset.
3. Replace pressure transmitter.

## LCD Display Update Failure

LCD display screen	(Not updating)
Local Operator Interface (LOI) screen	(Not updating)

The LCD display is not receiving updates from the pressure sensor.

### Recommended actions

1. Check the connection between the LCD display and the circuit board.
2. Replace the LCD display.
3. Replace the pressure transmitter.

## Configuration Changed

LCD display screen	(None)
Local Operator Interface (LOI) screen	(None)

A recent change has been made to the device by a secondary HART® master, such as a communication device.

### Recommended actions

1. Verify that the device's configuration change was intended and expected.
2. Clear this alert by selecting **Clear Configuration Changed Status**.
3. Connect a HART master, such as AMS Device Manager or similar, which will automatically clear the alert.

## Analog Output Fixed

LCD display screen	ANLOG FIXED
Local Operator Interface (LOI) screen	ANALOG FIXED

The analog output is fixed and does not represent the process measurement. This may be caused by other conditions in the device or because the device has been set to **Loop Test** or **Multidrop** mode.

#### Recommended actions

1. Take action on any other notifications from the device.
2. If the device is in **Loop Test** mode and should no longer be, disable or momentarily remove power.
3. If the device is in **Multidrop** mode and should not be, re-enable loop current by setting the polling address to 0.

## Simulation Active

The device is in **Simulation** mode and may not be reporting actual information.

#### Recommended actions

1. Verify that simulation is no longer required.
2. Disable **Simulation** mode in **Service Tools**.
3. Reset the device.

## Analog Output Saturated

LCD display screen ANLOG SAT

Local operator interface (LOI) screen ANALOG SAT

The analog output is saturated either high or low due to the pressure either above or below the range values.

#### Recommended actions

1. Check the applied pressure to ensure it is between 4 and 20 mA points.
2. Check the transmitter pressure connection to make sure it is not plugged and isolating diaphragms are not damaged.
3. Replace the pressure transmitter.

## 6.5 Disassembly procedures

### ⚠ WARNING

Do not remove the instrument cover in explosive atmospheres when the circuit is live.

### 6.5.1 Remove from service

1. Follow all plant safety rules and procedures.
2. Power down device.
3. Isolate and vent the process from the transmitter before removing the transmitter from service.
4. Remove all electrical leads and disconnect conduit.

5. Remove the transmitter from the process connection.
  - The Rosemount 2051C transmitter is attached to the process connection by four bolts and two cap screws. Remove the bolts and separate the transmitter from the process connection. Leave the process connection in place and ready for re-installation.
  - The 2051T transmitter is attached to the process by a single hex nut process connection. Loosen the hex nut to separate the transmitter from the process.

#### NOTICE

Do not wrench the transmitter's neck.

6. Clean isolating diaphragms with a soft rag and a mild cleaning solution, and rinse with clear water.

#### NOTICE

Do not scratch, puncture, or depress the isolating diaphragms.

7. 2051C: Whenever you remove the process flange or flange adapters, visually inspect the PTFE O-rings. Replace the O-rings if they show any signs of damage, such as nicks or cuts. Undamaged O-rings can be reused.

#### Related information

[Installation procedures](#)

[Inline process connection](#)

## 6.5.2 Remove terminal block

Electrical connections are located on the terminal block in the compartment labeled **FIELD TERMINALS**.

#### Procedure

1. Remove the housing cover from the field terminal side.
2. Loosen the two small screws located on the assembly in the 9 o'clock (270 degree angle) and 3 o'clock (90 degree angle) positions.
3. Pull the entire terminal block out to remove it.

## 6.5.3 Remove the electronics board

The transmitter electronics board is located in the compartment opposite the terminal side.

To remove the electronics board:

#### Procedure

1. Remove the housing cover opposite the field terminal side.
2. If you are disassembling a transmitter with an LCD display, loosen the two captive screws that are visible on the right and left side of the meter display.

## NOTICE

The two screws anchor the LCD display to the electronics board and the electronics board to the housing. The electronics board is electrostatically sensitive.

Observe handling precautions for static-sensitive components. Use caution when removing the LCD, as there is an electronic pin connector that interfaces between the LCD and electronics board.

3. Using the two captive screws, slowly pull the electronics board out of the housing. The sensor module ribbon cable holds the electronics board to the housing. Disengage the ribbon cable by pushing the connector release.

## 6.5.4 Remove the sensor module from the electronics housing

### Procedure

1. Remove the electronics board.

## NOTICE

To prevent damage to the sensor module ribbon cable, disconnect it from the electronics board before removing the sensor module from the electrical housing.

2. Carefully tuck the cable connector completely inside of the internal black cap.

## NOTICE

The black cap protects the ribbon cable from damage that can occur when you rotate the housing.

Do not remove the housing until after you tuck the cable connector completely inside of the internal black cap.

3. Using a  $\frac{5}{64}$ -inch hex wrench, loosen the housing rotation set screw one full turn.
4. Unscrew the module from the housing.

### Note

Ensure the black cap and sensor cable do not catch on the housing.

### Related information

[Remove the electronics board](#)

## 6.6 Reassembly procedures

### 6.6.1 Replace the electronics housing in the sensor module

#### Procedure

1. Inspect all cover and housing (non-process wetted) O-rings. Replace damaged O-rings.
2. Lightly grease with silicone lubricant to ensure a good seal.

3. Carefully tuck the cable connector completely inside the internal black cap.
  - a) To tuck the cable connector, turn the black cap and cable counterclockwise one rotation to tighten the cable.
4. Lower the electronics housing onto the module.
5. Guide the internal black cap and cable through the housing and into the external black cap.
6. Turn the module clockwise into the housing.

#### NOTICE

Damage can occur to the cable if the internal black cap and ribbon cable become hung up and rotate with the housing.

Ensure the sensor ribbon cable and internal black cap remain completely free of the housing as you rotate it.

7. Thread the housing completely onto the sensor module.

#### ⚠ WARNING

The housing must be no more than one full turn from flush with the sensor module to comply with explosion proof requirements.

8. Using a  $\frac{5}{64}$ -inch hex wrench, tighten the housing rotation set screw .

#### Note

Tighten to a maximum of 7 in.-lb. when the desired location is reached.

## 6.6.2 Attach the electronics board

### Procedure

1. Remove the cable connector from its position inside of the internal black cap.
2. Attach it to the electronics board.
3. Using the two captive screws as handles, insert the electronics board into the housing.

#### Note

Ensure the posts from the electronics housing properly engage the receptacles on the electronics board. Do not force. The electronics board should slide gently on the connections.

4. Tighten the captive mounting screws.
5. Replace the electronics housing cover.

#### ⚠ WARNING

The transmitter covers must be engaged metal-to-metal to ensure a proper seal and to meet explosion-proof requirements.



## 6.6.3 Install the terminal block

### Procedure

1. Gently slide the terminal block into place.

#### Note

Ensure the two posts from the electronics housing properly engage the receptacles on the terminal block.

2. Tighten the captive screws.
3. Replace the electronics housing cover.

#### ⚠ WARNING

The transmitter covers must be fully engaged to meet explosion-proof requirements.

## 6.6.4 Reassemble the Rosemount 2051C process flange

### Procedure

1. Inspect the sensor module PTFE O-rings.  
Undamaged O-rings may be reused. Replace O-rings that show any signs of damage, such as nicks, cuts, or general wear.

#### NOTICE

If you are replacing the O-rings, be careful not to scratch the O-ring grooves or the surface of the isolating diaphragm when removing the damaged O-rings.

2. Install the process connection. Possible options include:
  - Coplanar™ process flange:
    - a. Hold the process flange in place by installing the two alignment screws to finger tightness (screws are not pressure retaining).

#### ⚠ WARNING

Do not over-tighten as this will affect module-to-flange alignment.

- b. Install the four 1-.75-inch flange bolts to the flange by finger-tightening.
- Coplanar process flange with flange adapters:
  - a. To secure process flange placement, finger tighten the two alignment screws. Screws are not pressure retaining.

#### ⚠ WARNING

Do not over-tighten as this will affect module-to-flange alignment.

- b. Hold the flange adapters and adapter O-rings in place while installing (in one of the four possible process connection spacing connections), using

four 2.88-inch bolts to mount securely to the coplanar flange. For gauge pressure configurations, use two 2.88-inch bolts and two 1.75-inch bolts.

- Manifold:  
Contact the manifold manufacturer for the appropriate bolts and procedures.
3. Tighten the bolts to the initial torque value using a crossed pattern. See [Table 6-1](#) for appropriate torque values.

**Table 6-1: Bolt installation torque values**

Bolt material	Initial torque value	Final torque value
CS-ASTM-A445 Standard	300 in.-lb. (34 N-m)	650 in.-lb. (73 N-m)
316 stainless steel (SST)—Option L4	150 in.-lb. (17 N-m)	300 in.-lb. (34 N-m)
ASTM-A-193-B7M—Option L5	300 in.-lb. (34 N-m)	650 in.-lb. (73 N-m)
ASTM-A-193 Class 2, Grade B8M—Option L8	150 in.-lb. (17 N-m)	300 in.-lb. (34 N-m)

## NOTICE

If you replaced the PTFE sensor module O-rings, re-torque the flange bolts after installation to compensate for cold flow.

### Note

After replacing O-rings on Range 1 transmitters and re-installing the process flange, expose the transmitter to a temperature of +185 °F (+85 °C) for two hours. Then re-tighten the flange bolts in a cross pattern and again expose the transmitter to a temperature of +185 °F (+85 °C) for two hours before calibration.

4. Using the same cross pattern, tighten bolts to the final torque values seen in [Table 6-1](#).

## 6.6.5 Install the drain/vent valve

### Procedure

1. Beginning at the valve base with the threaded end pointing at the installer, apply two clockwise turns of sealing tape to the threads on the seat.
2. Tighten the drain/vent valve to 250 in.-lb. (28.25 N-m).
3. Ensure the opening is placed on the valve so that process fluid will drain toward the ground and away from human contact when the valve is opened.

# 7 Safety Instrumented Systems (SIS) requirements

## SIS certification

The safety-critical output of the Rosemount 2051 is provided through a two-wire, 4–20 mA signal representing pressure. The 2051 safety certified pressure transmitter is certified to: Low Demand; Type B.

- Safety integrity level (SIL) 2 for random integrity at HFT=0
- SIL 3 for random integrity at HFT=1
- SIL 3 for systematic integrity

## 7.1 Identify safety certified transmitters

All Rosemount 2051 Transmitters must be identified as safety certified before installing into Safety Instrumented Systems (SIS).

To identify a safety certified 2051C, 2051T, or 2051L:

### Procedure

Check NAMUR Software Revision located on the metal device tag. SW \_ . \_ . \_

<b>NAMUR software revision number</b>	SW 1.0.x - 1.4.x
<b>Transmitter output code</b>	A (4–20 mA HART® Protocol)

## 7.2 Installation in Safety Instrumented Systems (SIS) applications

### ⚠ WARNING

Only qualified personnel should install the transmitter. No special installation is required in addition to the standard installation practices outlined in this document. Always ensure a proper seal by installing the electronics housing cover(s) so that metal contacts metal.

Environmental and operational limits are available in the [Rosemount 2051 Pressure Transmitter Product Data Sheet](#).

Design the loop so that the terminal voltage does not drop below 10.5 Vdc when the transmitter output is set to 23 mA.

Position the security switch to locked (🔒) position to prevent accidental or deliberate change of configuration data during normal operation.

## 7.3 Configuring in Safety Instrumented Systems (SIS) applications

Use any HART® protocol capable configuration tool to communicate with and verify configuration of the Rosemount 2051.

---

### Note

Transmitter output is not safety-rated during the following: Configuration changes, multidrop, and loop test. Use alternative means to ensure process safety during transmitter configuration and maintenance activities.

---

### 7.3.1 Damping

User-selected damping will affect the transmitter's ability to respond to changes in the applied process.

The damping value + response time must not exceed the loop requirements.

#### Related information

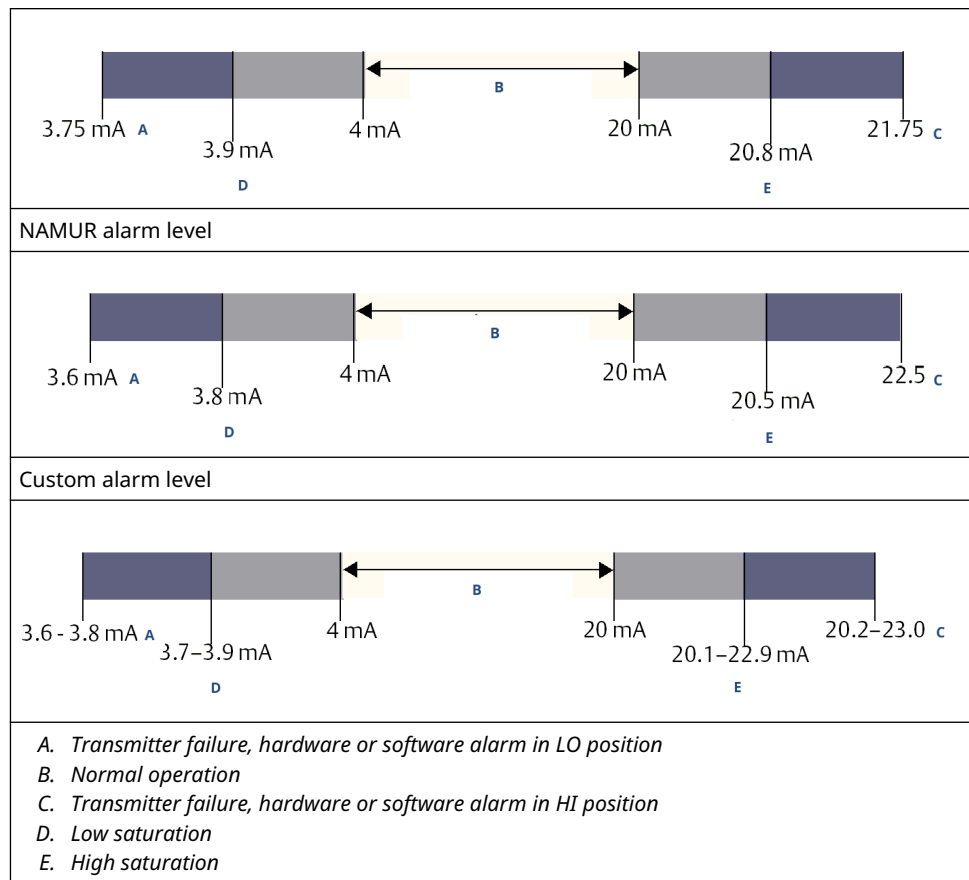
[Damping](#)

### 7.3.2 Alarm and saturation levels

Configure distributed control systems (DCS) or safety logic solver to match transmitter configuration.

[Figure 7-1](#) identifies the three alarm levels available and their operation values.

Figure 7-1: Alarm levels



## 7.4 Safety Instrumented System (SIS) operation and maintenance

### 7.4.1 Proof tests

Emerson recommends the following proof tests.

If an error is found in the safety and functionality, document proof test results and corrective actions taken at [Measurement Instrumentation Solutions Customer Service](#).

#### ⚠ WARNING

Ensure that qualified personnel carry out all proof test procedures.

Use [Communication device fast keys](#) to perform a loop test, analog output trim, or sensor trim. Unlock (🔓) **Security** switch during proof test execution and reposition it in locked (🔒) position after execution.

## 7.4.2 Perform simple proof test

The simple suggested proof test consists of a power cycle plus reasonability checks of the transmitter output.

Reference the *FMEDA Report* for percent of possible DU failures in the device.

### Prerequisites

Required tools: Communication device and mA meter.

### Procedure

1. Bypass the safety function and take appropriate action to avoid a false trip.
2. Use HART® communications to retrieve any diagnostics and take appropriate action.
3. Send a HART command to the transmitter to go to the high alarm current output and verify that the analog current reaches that value<sup>(2)</sup>.
4. Send a HART command to the transmitter to go to the low alarm current output and verify that the analog current reaches that value<sup>(2)</sup>.
5. Remove the bypass and otherwise restore the normal operation.
6. Place the **Security** switch in locked (🔒) position.

### Related information

[Verifying alarm level](#)

## 7.4.3 Perform comprehensive proof test

The comprehensive proof test consists of performing the same steps as the simple suggested proof test but with a two point calibration of the pressure sensor instead of the reasonability check.

Reference the *FMEDA Report* for percent of possible DU failures in the device.

### Prerequisites

Required tools: communication device and pressure calibration equipment.

### Procedure

1. Bypass the safety function and take appropriate action to avoid a false trip.
2. Use HART® communications to retrieve any diagnostics and take appropriate action.
3. Send a HART command to the transmitter to go to the high alarm current output and verify that the analog current reaches that value.
4. Send a HART command to the transmitter to go to the low alarm current output and verify that the analog current reaches that value<sup>(3)</sup>.
5. Perform a two-point calibration of the sensor over the full working range and verify the current output at each point.
6. Remove the bypass and otherwise restore the normal operation.
7. Place the **Security** switch in the locked (🔒) position.

---

### Note

- The user determines the proof test requirements for impulse piping.

---

<sup>(2)</sup> This tests for possible quiescent current related failures.

<sup>(3)</sup> This tests for compliance voltage problems, such as a low loop power supply voltage or increased wiring distance. This also tests for other possible failures.

- Automatic diagnostics are defined for the corrected % DU: The tests performed internally by the device during runtime without requiring the user to enable or program them.

#### 7.4.4 Calculation of average probability of failure on demand (PFD<sub>AVG</sub>)

See the *FMEDA Report* for the PFD<sub>AVG</sub> calculation.

### 7.5 Inspection

#### 7.5.1 Visual inspection

Not required.

#### 7.5.2 Special tools

Not required.

#### 7.5.3 Product repair

To repair the product, replace major components.

Report all failures detected by the transmitter diagnostics or by the proof-test. Submit feedback electronically at [Emerson.com/ContactUs](https://emerson.com/contact-us).

#### **⚠ WARNING**

Ensure only qualified personnel repair the product and replace parts.

#### 7.5.4 Safety Instrumented Systems (SIS) reference

Operate the product in accordance with the functional and performance specifications provided in the [Rosemount 2051 Pressure Transmitter Product Data Sheet](#).

#### 7.5.5 Failure rate data

The *FMEDA Report* includes failure rates and common cause Beta factor estimates.

#### 7.5.6 Failure values

<b>Safety accuracy</b>	±2.0 percent
<b>Transmitter response time</b>	1.5 seconds
<b>Self-diagnostics test</b>	At least once every 60 minutes

## 7.5.7 Product life

50 years - based on worst case component wear-out mechanisms; not based on wear-out of process wetted materials



# A Reference data

## A.1 Product certifications

To view current Rosemount 2051 Pressure Transmitter product certifications:

### Procedure

1. Go to the [Rosemount 2051 Coplanar™ Pressure Transmitter Product Detail Page](#).
2. Scroll as needed to the green menu bar and click **Documents & Drawings**.
3. Click **Manuals & Guides**.
4. Select the appropriate Quick Start Guide.

## A.2 Ordering information, specifications, and drawings

To view current Rosemount 2051 Pressure Transmitter ordering information, specifications, and drawings:

### Procedure

1. Go to the [Rosemount 2051 Coplanar™ Pressure Transmitter Product Detail Page](#).
2. Scroll as needed to the green menu bar and click **Documents & Drawings**.
3. For installation drawings, click **Drawings & Schematics** and select the appropriate document.
4. For ordering information, specifications, and dimensional drawings, click **Data Sheets & Bulletins** and select the appropriate Product Data Sheet.



# B Communication device menu trees and fast keys

## B.1 Communication device menu trees

**Note**

Selections with black circle are only available in HART® Revision 7 mode. Selection will not appear in HART Revision 5 device descriptor (DD).

**Figure B-1: Overview**

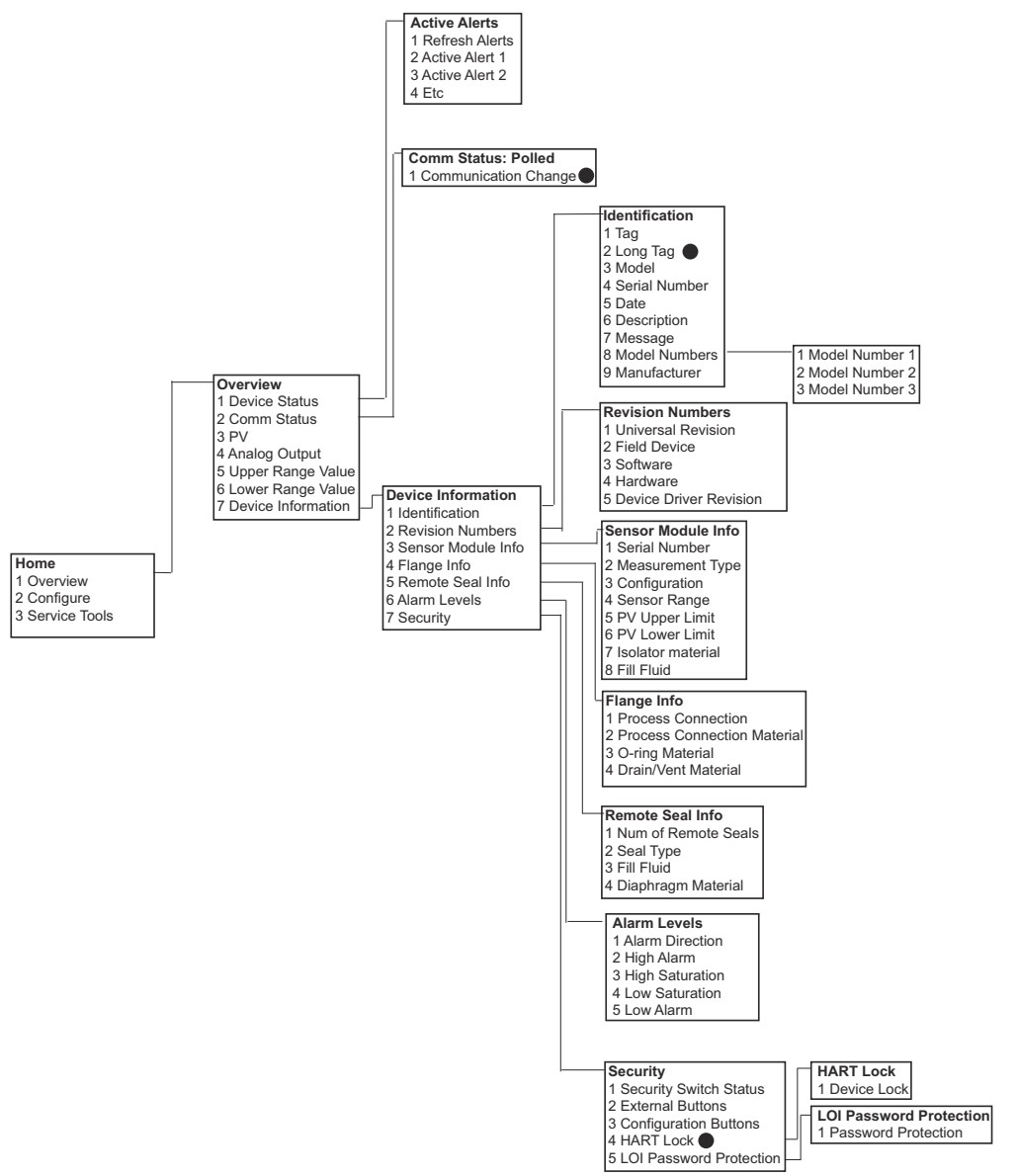


Figure B-2: Configure → Guided Setup

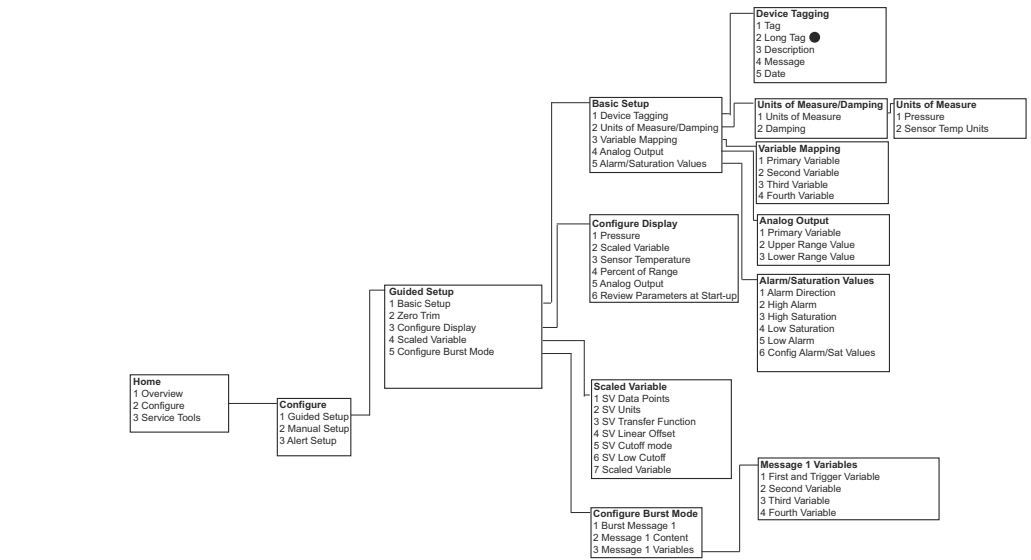


Figure B-3: Configure Manual Setup

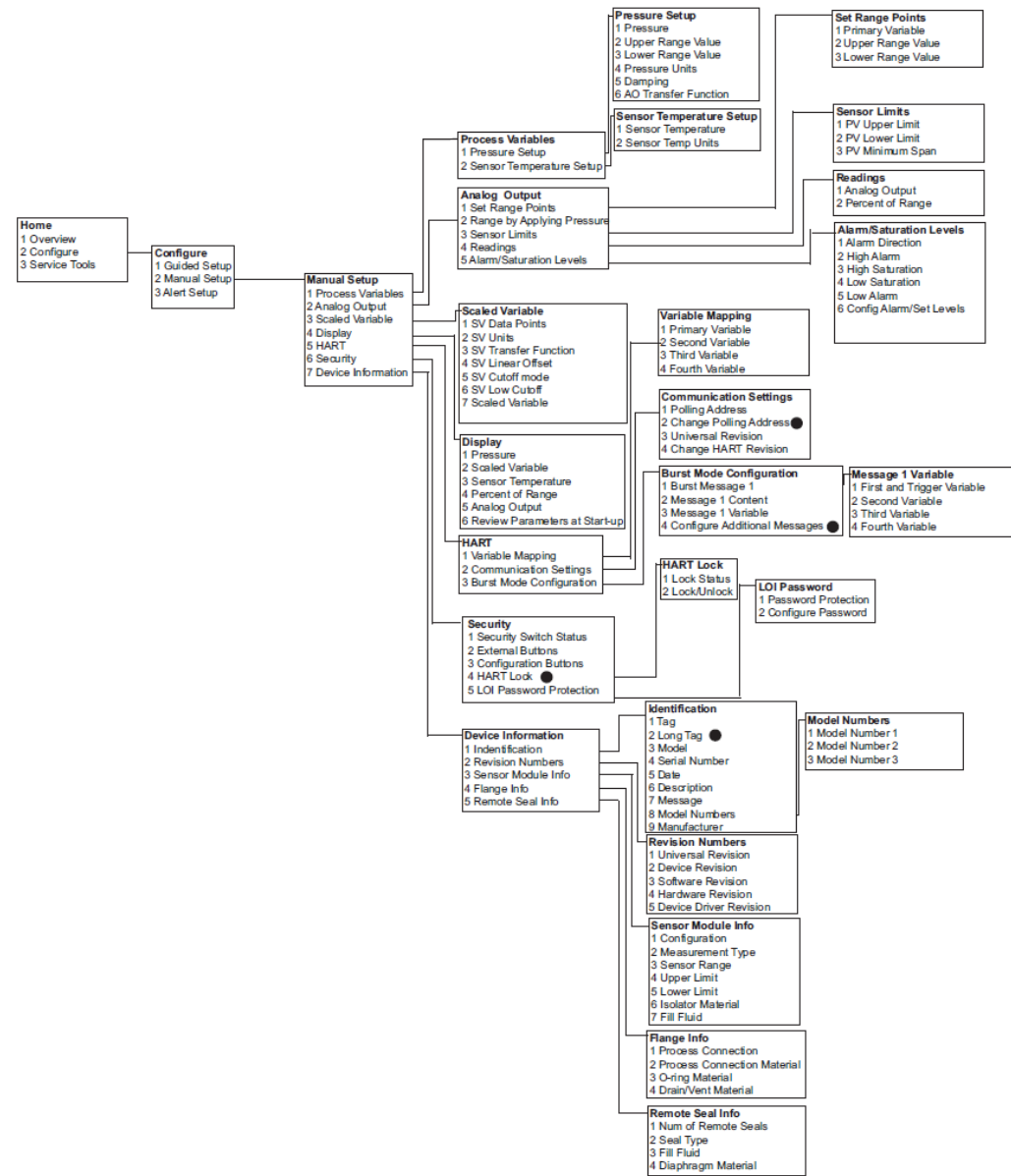


Figure B-4: Configure Alert Setup

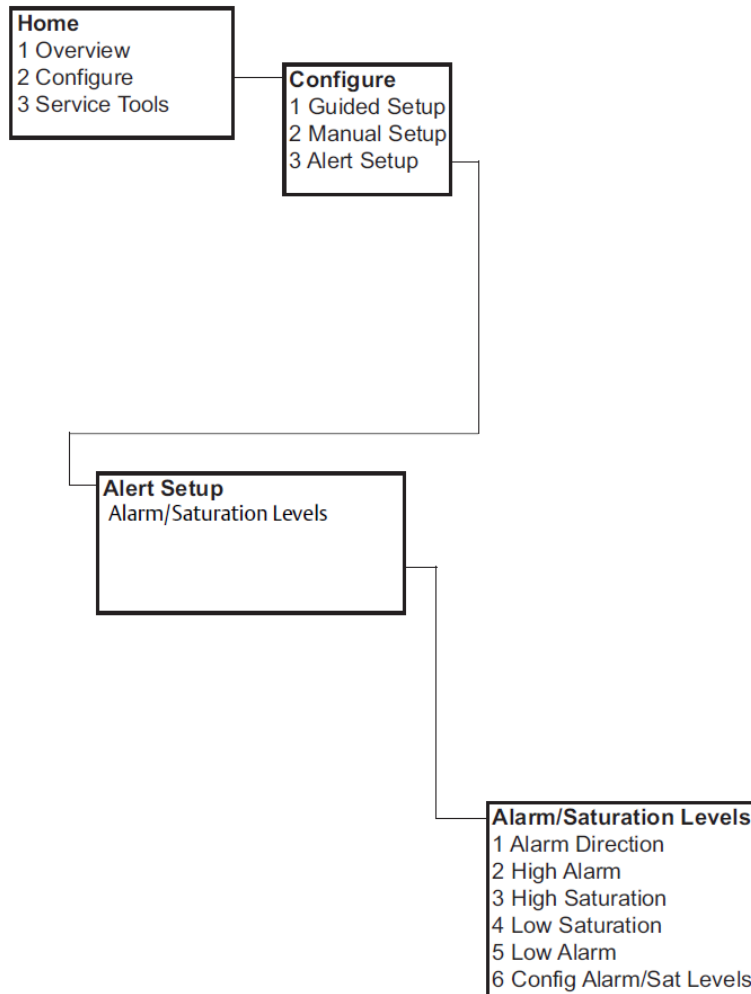
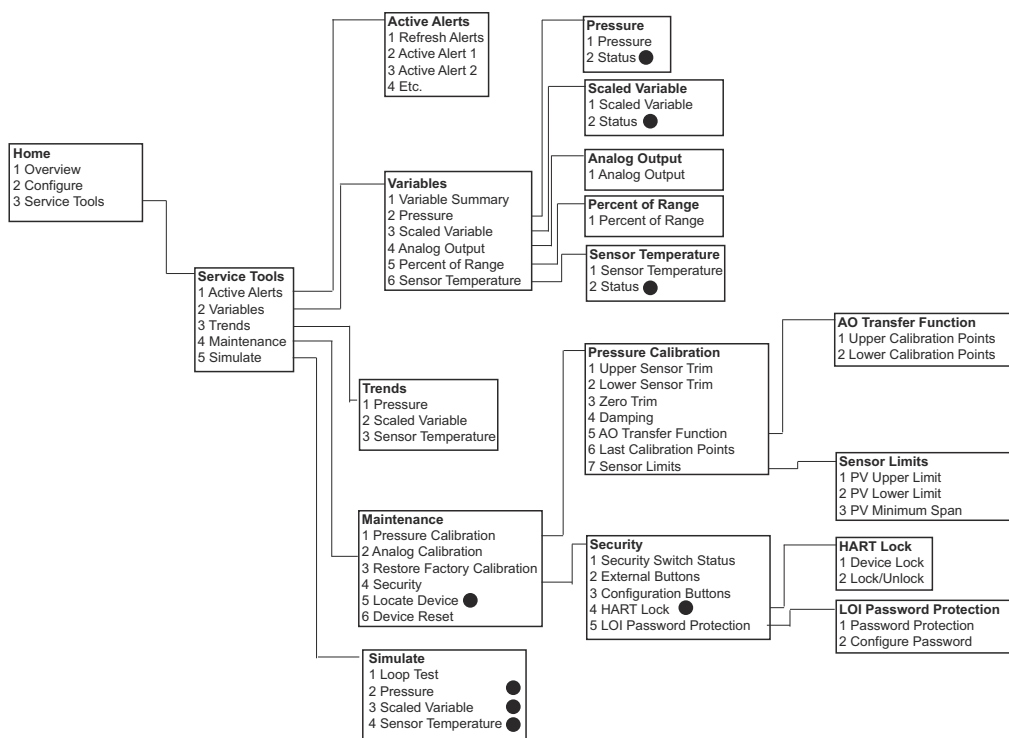


Figure B-5: Service Tools



## B.2 Communication device fast keys

- A (✓) indicates the basic configuration parameters. At minimum, verify these parameters as a part of configuration and start-up.
- A 7 indicates availability only in HART® revision 7 mode.

Table B-1: Device revision 9 and 10 (HART 7), device descriptor (DD) revision 1 fast key sequence

	Function	Fast key sequence	
		HART 7	HART 5
✓	Alarm and Saturation Levels	2, 2, 2, 5	2, 2, 2, 5
✓	Damping	2, 2, 1, 1, 5	2, 2, 1, 1, 5
✓	Primary Variable	2, 2, 5, 1, 1	2, 2, 5, 1, 1
✓	Range Values	2, 2, 2, 1	2, 2, 2, 1
✓	Tag	2, 2, 7, 1, 1	2, 2, 7, 1, 1
✓	Transfer Function	2, 2, 1, 1, 6	2, 2, 1, 1, 6
✓	Pressure Units	2, 2, 1, 1, 4	2, 2, 1, 1, 4
	Date	2, 2, 7, 1, 5	2, 2, 7, 1, 4
	Descriptor	2, 2, 7, 1, 6	2, 2, 7, 1, 5
	Digital to Analog Trim (4 - 20 mA / 1-5 V Output)	3, 4, 2, 1	3, 4, 2, 1
	Digital Zero Trim	3, 4, 1, 3	3, 4, 1, 3

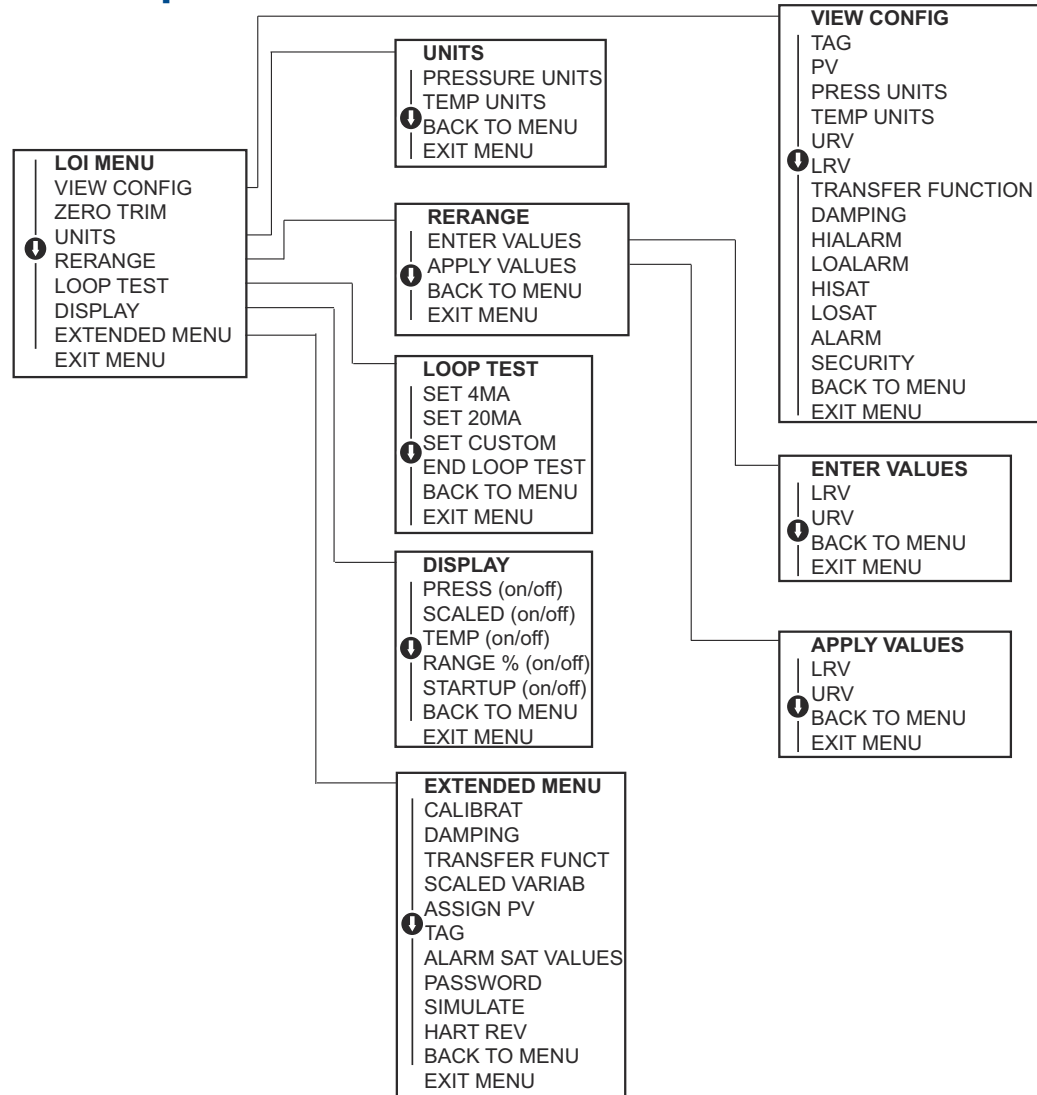
**Table B-1: Device revision 9 and 10 (HART 7), device descriptor (DD) revision 1 fast key sequence (continued)**

	Function	Fast key sequence	
		HART 7	HART 5
	Display Configuration	2, 2, 4	2, 2, 4
	Local Operator Interface (LOI) Password Protection	2, 2, 6, 5	2, 2, 6, 4
	Loop Test	3, 5, 1	3, 5, 1
	Lower Sensor Trim	3, 4, 1, 2	3, 4, 1, 2
	Message	2, 2, 7, 1, 7	2, 2, 7, 1, 6
	Pressure Trend	3, 3, 1	3, 3, 1
	Rerange with Keypad	2, 2, 2, 1	2, 2, 2, 1
	Scaled D/A Trim (4 - 20 mA / 1-5 V) Output)	3, 4, 2, 2	3, 4, 2, 2
	Scaled Variable	2, 2, 3	2, 2, 3
	Sensor Temperature Trend	3, 3, 3	3, 3, 3
	Switch HART Revision	2, 2, 5, 2, 4	2, 2, 5, 2, 3
	Upper Sensor Trim	3, 4, 1, 1	3, 4, 1, 1
7	Long Tag	2, 2, 7, 1, 2	
7	Locate Device	3, 4, 5	
7	Simulate Digital Signal	3, 5	

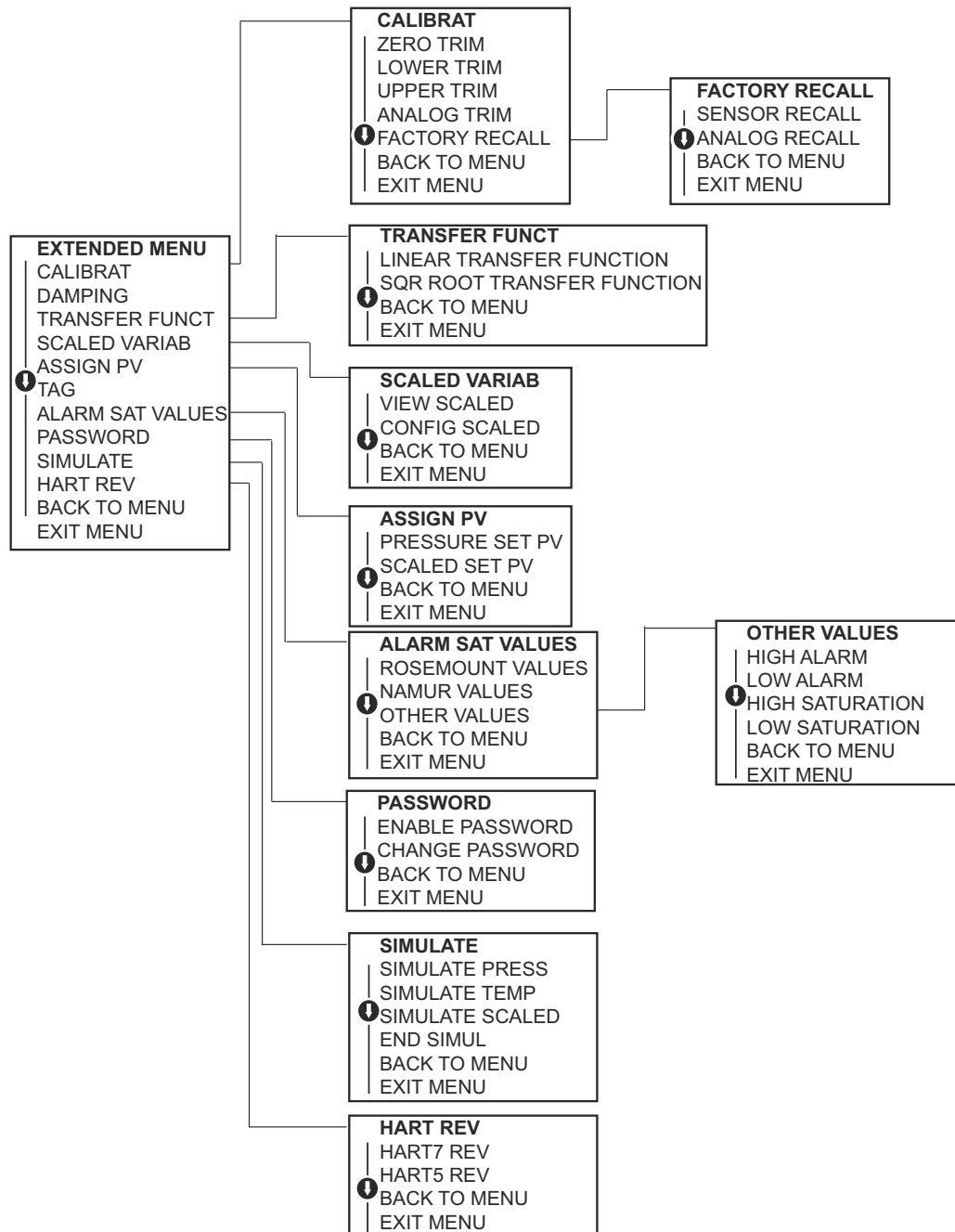


# C Local operator interface (LOI) menu

## C.1 Local operator interface (LOI) menu tree



## C.2 Local operator interface (LOI) menu tree - *EXTENDED MENU*



## C.3 Enter numbers

You can enter floating-point numbers with the local operator interface (LOI).

You can use all eight number locations on the top line for number entry. Below is a floating-point number entry example for changing a value of -0000022 to 000011.2.

Step	Instruction	Current position (indicated by bold underline)
1	When the number entry begins, the left most position is the selected position. In this example, the negative symbol, “-”, will be flashing on the screen.	-0000022
2	Press the <b>scroll</b> button until the 0 is blinking on the screen in the selected position.	<b>0</b> 0000022
3	Press the <b>enter</b> button to select the 0 as an entry. The second digit from the left will be blinking.	0 <b>0</b> 000022
4	Press the <b>enter</b> button to select 0 for second digit. The third digit from the left will be blinking.	00 <b>0</b> 00022
5	Press the <b>enter</b> button to select 0 for the third digit. The fourth digit from the left will now be blinking.	000 <b>0</b> 0022
6	Press the <b>enter</b> button to select 0 for the fourth digit. The fifth digit from the left will now be blinking.	0000 <b>0</b> 022
7	Press <b>scroll</b> to navigate through the numbers until the 1 is on the screen.	0000 <b>1</b> 022
8	Press the <b>enter</b> button to select the 1 for the fifth digit. The sixth digit from the left will now be blinking.	00001 <b>0</b> 22
9	Press <b>scroll</b> to navigate through the numbers until the “1”, is on the screen.	00001 <b>1</b> 22
10	Press the <b>enter</b> button to select the 1 for the sixth digit. The seventh digit from the left will now be blinking.	000011 <b>2</b> 2
11	Press <b>scroll</b> to navigate through the numbers until the decimal, “.”, is on the screen.	000011, <b>2</b>
12	Press the <b>enter</b> button to select the decimal, “.”, for the seventh digit. After pressing enter, all digits to the right of the decimal will now be zero. The eighth digit from the left will now be blinking.	000011. <b>0</b>
13	Press the <b>scroll</b> button to navigate through the numbers until the 2 is on the screen.	000011. <b>2</b>
14	Press the <b>enter</b> button to select the 2 for the eighth digit. The number entry will be complete, and a <b>SAVE</b> screen will be shown.	000011. <b>2</b>

### Note

- It is possible to move backwards in the number by scrolling to the left arrow symbol and pressing enter.
- The negative symbol is only allowed in the left most position.
- Numbers can be entered in scientific notation by placing an **E** in the 7th position.

### Related information

[Configuring with a local operator interface \(LOI\)](#)

## C.4 Text entry

You can enter text with the local operator interface (LOI).

Depending on the edited item, you can use up to eight locations on the top line for text entry. Text entry follows the same rules as the number entry rules in [Local operator interface \(LOI\) menu tree](#), except the following characters are available in all locations: A-Z, 0-9, -, /, space.

---

### Note

If the current text contains a character the LOI cannot display, it will be shown as an asterisk "\*".

---



For more information: [Emerson.com/global](https://emerson.com/global)

©2024 Emerson. All rights reserved.

Emerson Terms and Conditions of Sale are available upon request. The Emerson logo is a trademark and service mark of Emerson Electric Co. Rosemount is a mark of one of the Emerson family of companies. All other marks are the property of their respective owners.

**ROSEMOUNT™**

