

# Rosemount 1154

Alphaline<sup>®</sup> Nuclear Pressure Transmitter

Product Discontinued

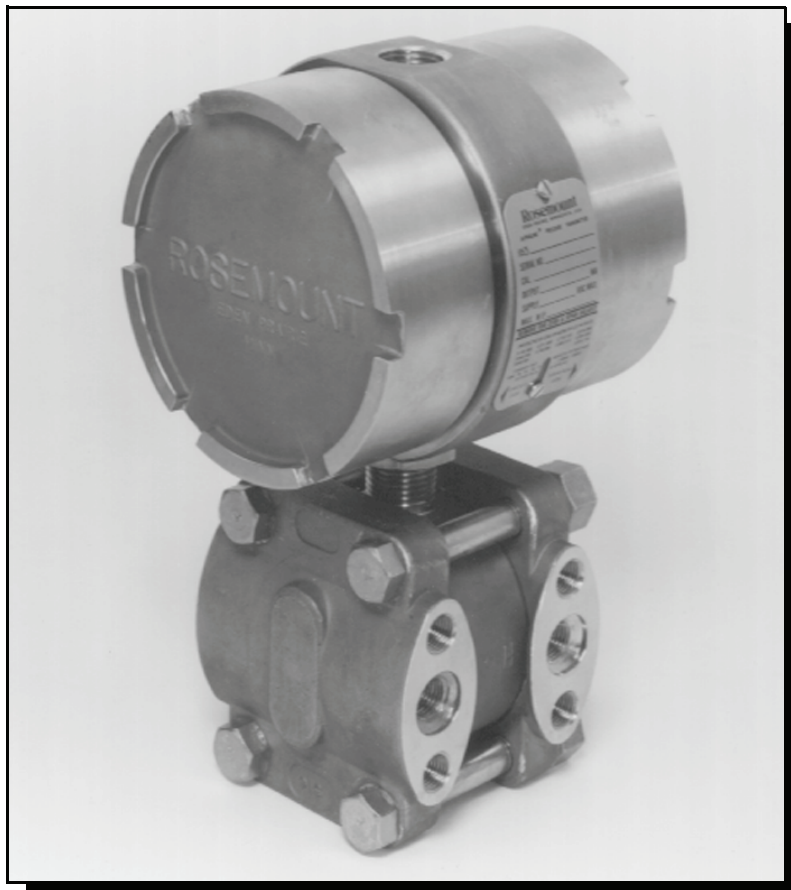

CE

**IMPORTANT NOTICE – ERRATA**

Model 1154 Product Manual 00809-0100-4514 Rev BA (January 2008)

| No. | Affected Pages | Description of Change   | Effect. Date |
|-----|----------------|---|--------------|
| 1   | 6-6            | Process Flangel – CF3M (Cast version of 316L SST)<br>Drain/Vent Valves – 316L SST<br>Process Connections – 3/8-inch Swagelok compression fitting, 316L SST (1/4-18 NPT optional)  | 10/21/09     |
| 2   | 3-5            | Change the first paragraph on the page to read as follows:<br><br>“Damping electronics are available as an option. Transmitters with standard electronics can be retrofitted with the adjustable damping feature by changing out both the amplifier board and the calibration board. Please reference Table 6-2 (Rosemount 1154DP, 1154HP, and 1154GP Spare Parts List) for the applicable part numbers.”   | 4/13/12      |
| 3   | 6-9            | Table 6-2, “Rosemount 1154DP, 1154HP, and 1154GP Spare Parts List”, in all locations the following part numbers are updated:<br><br><u>Amplifier Circuit Board, Output Code R:</u><br>“01154-0001-0005” is replaced by “01154-0153-0001”<br><br><u>Amplifier Circuit Board with Damping, Output Code R:</u><br>“01154-0021-0004” is replaced by “01154-0156-0001”<br><br><u>Amplifier Circuit Board, Output Code R, N0026:</u><br>“01154-0001-0006” is replaced by “01154-0153-0002”<br><br><u>Sensor Module, 316 SST<sup>(5)</sup></u><br>0-25/150 inH <sub>2</sub> O: “01154-0300-0242” is replaced by “01154-5300-0242”<br>“01154-0300-0342” is replaced by “01154-5300-0342”<br>“01154-0300-0142” is replaced by “01154-5300-0142”<br><br>0-125/750 inH <sub>2</sub> O: “01154-0300-0252” is replaced by “01154-5300-0252”<br>“01154-0300-0352” is replaced by “01154-5300-0352”<br>“01154-0300-0152” is replaced by “01154-5300-0152”<br><br>0-17/100 psi: “01154-0300-0262” is replaced by “01154-5300-0262”<br>“01154-0300-0362” is replaced by “01154-5300-0362”<br>“01154-0300-0162” is replaced by “01154-5300-0162”<br><br>0-50/300 psi: “01154-0300-0272” is replaced by “01154-5300-0272”<br>“01154-0300-0372” is replaced by “01154-5300-0372”<br>“01154-0300-0172” is replaced by “01154-5300-0172”<br><br>0-170/1,000 psi: “01154-0300-0282” is replaced by “01154-5300-0282”<br>“01154-0300-0182” is replaced by “01154-5300-0182”<br><br>0-500/3,000 psi: “01154-0300-0192” is replaced by “01154-5300-0192”<br><br>0-1,000/4,000 psi: “01154-0300-0102” is replaced by “01154-5300-0102” | 4/13/12      |
| 4   | 6-10           | Table 6-2, “Rosemount 1154DP, 1154HP, and 1154GP Spare Parts List”, the table footnotes are updated to add note (5) which will read as follows:<br><b>(5) IMPORTANT NOTICE: To maintain a transmitter’s qualified configuration, when purchasing or installing a new Sensor Module, Rosemount Qualification report D2011019 must be carefully reviewed to verify that the Sensor Module to be installed and the associated Amplifier Circuit Board in a given transmitter is a qualified configuration.</b> As detailed in the referenced report, not all Sensor Module part numbers are considered qualified in conjunction with certain Amplifier Circuit Boards.   | 4/13/12      |
| 5   | 6-11           | Table 6-2, “Rosemount 1154DP, 1154HP, and 1154GP Spare Parts List”, in all locations the following part numbers are updated:<br><br><u>Amplifier Circuit Board, Output Code R:</u><br>“01154-0153-0001” is replaced by “01154-0263-0001”<br><br><u>Amplifier Circuit Board with Damping, Output Code R:</u><br>“01154-0156-0001” is replaced by “01154-0266-0001”<br><br><u>Amplifier Circuit Board, Output Code R, N0026:</u><br>“01154-0153-0002” is replaced by “01154-0263-0002”  | 6/9/17       |

# Rosemount 1154 Alphaline<sup>®</sup> Nuclear Pressure Transmitter

## NOTICE

Read this manual before working with the product. For personal and system safety and optimum product performance make sure you thoroughly understand the contents before installing, using, or maintaining this product.

For equipment service needs outside the United States, contact the nearest Rosemount representative.

Within the United States, the North American Response Center is at your service 24 hours a day, and is a single-point contact for all Rosemount equipment service needs. If at any time you are not sure what to do, have a question about using the product, or have a service or support request, call the center toll-free at 1-800-654-RSMT (7768). This contact is your fastest link to quick and complete answers about any Rosemount Group product or service.

*Alphaline, Rosemount and the Rosemount logotype are registered trademarks of Rosemount Inc.*

*δ-Cell is a trademark of Rosemount Inc.*

*Loctite is a registered trademark of Henkel HGaA Corporation.*

*Swagelok is a registered trademark of Swagelok Company.*

*D.C. 55 is a registered trademark of Dow Corning Corporation.*

*Lubri-Bond is a registered trademark of E/M Corporation*

*Grafoil is a trademark of Union Carbide Corp.*

*Cover Photo: 1153-001AB*

 Rosemount Nuclear Instruments, Inc. satisfies all obligations coming from legislation to harmonize product requirements in the European Union.

# Rosemount Nuclear Instruments, Inc. Warranty and Limitations of Remedy

The warranty and limitations of remedy applicable to this Rosemount equipment are as stated on the reverse of the current Rosemount quotation and customer acknowledgment forms.

## RETURN OF MATERIAL

Authorization for return is required from Rosemount Nuclear Instruments, Inc. prior to shipment. Contact the Nuclear Instruments Group (952-949-5210) for details on obtaining "Returned Material Authorization (RMA)". **Rosemount Nuclear Instruments will not accept any returned material without a Returned Material Authorization.** Materials returned without authorization are subject to return to customer.

Material returned for repair, whether in or out of warranty, should be shipped prepaid to:

Rosemount Nuclear Instruments, Inc.  
8200 Market Blvd  
Chanhassen, MN 55317  
USA

## IMPORTANT

The Rosemount 1154 Alkaline Pressure Transmitter is designed for nuclear use, has been tested per IEEE Std 323-1974 and IEEE Std 344-1975 as defined in Rosemount Report D8400102, and is manufactured to the requirements of NQA-1; 10CFR50, Appendix B quality assurance programs; and 10CFR Part 21. During qualification testing, interfaces were defined between the transmitter and its environment that are essential to meeting IEEE Std 323-1974 requirements. To ensure compliance with 10CFR Part 21, the transmitter must comply with the requirements herein throughout its installation, operation and maintenance. It is incumbent upon the user to ensure that the Rosemount Nuclear Instruments, Inc.'s component traceability program is continued throughout the qualified life of the transmitter.

In order to maintain the qualified status of the transmitter, the essential environmental interfaces must not be compromised. Performance of any operations on the transmitter other than those specifically authorized in this manual may compromise an essential environmental interface.

Where the manual uses the terms *requirements*, *mandatory*, *must*, or *required*, the instructions so referenced must be carefully followed. Rosemount Nuclear Instruments, Inc. expressly disclaims all responsibility and liability for transmitters for which the foregoing has not been complied with by the user.

# Revision Status

## Changes From June 1999 to January 2008

| Page (New)                            | Page (Old)                 | Changes  |
|---------------------------------------|----------------------------|--|
| Cover                                 | Cover                      | Document revision dates changed from June 1999 to January 2008, rev from AA to BA.   |
| Inside Cover, i, ii, 5-8 & Back Cover | ii, 5-9, 5-10 & Back Cover | Include errata sheet information on address and phone number.  |
| 3-5, 6-8 & 6-9                        | 3-5, 6-9 & 6-10            | Include errata sheet information on circuit board number changes: <ul style="list-style-type: none"> <li>• Replaced amplifier circuit card, output code R P/N 01154-0001-0001 with 01154-0001-0005.</li> <li>• Replaced amplifier circuit card with damping, output code R P/N 01154-0021-0002 with 01154-0021-0004.</li> <li>• Replaced amplifier circuit card, output code R, N0026 P/N 01154-0001-0002 with 01154-0001-0006.</li> </ul> |
| Throughout                            | Throughout                 | References to Fisher-Rosemount were changed to Emerson Process Management.   |
| i, back cover                         | Cover, i, ii & back cover  | Web address changed from www.rosemount.com to www.rosemountnuclear.com.  |
| -                                     | Cover, i, back page        | Added reference to European Union product requirement (CE).  |
| 2-1,3-1,4-1,5-1, 6-1                  | 2-1,3-1,4-1,5-1, 6-1       | Added table of contents to each section  |
| 2-2                                   | 2-2                        | Removed the word "process" from sentence indicating user assumes responsibility for qualifying the connection interface.   |
| 2-2                                   | 2-3                        | Updated reference to Swagelok catalog and added web address, removed street address.   |
| 2-4                                   | 2-4                        | Removed reference to 353C  |
| 2-4                                   | 2-5                        | Rearranged wording on shielded cable.  |
| 2-6 & 2-7                             | 2-6 & 2-7                  | Added word "nominal" to Notes in drawings. Changed significant digits to conform to standard.  |
| 5-7 & 6-9                             | 5-8 & 6-10                 | Inserted information on the spare parts kit for bolts and nuts for process flange.   |
| 6-1                                   | 6-2                        | Changed ISO 9001 to ISO 9001:2000  |
| 6-9                                   | 6-10                       | Replaced pipe mount bracket kit (adapters) P/N 01154-0038-0001 with P/N 01154-0044-0001  |
| -                                     | Back Cover                 | Added trademark & registration information   |

### NOTE

The above Revision Status list summarizes the changes made. Please refer to both manuals for complete comparison details.



# Table of Contents

|                     |   |     |
|---------------------|---|-----|
| <b>SECTION 1</b>    | Overview . . . . .  | 1-1 |
| <b>Introduction</b> | About The Transmitter . . . . .   | 1-1 |
| <b>SECTION 2</b>    | Overview . . . . .  | 2-1 |
| <b>Installation</b> | General Considerations . . . . .  | 2-1 |
|                     | Mechanical Considerations . . . . .   | 2-2 |
|                     | Process Connections . . . . .   | 2-2 |
|                     | Conduit . . . . .   | 2-4 |
|                     | Electrical Considerations . . . . .   | 2-4 |
|                     | Installation Procedures . . . . .   | 2-6 |
|                     | Mechanical . . . . .  | 2-6 |
|                     | Transmitter . . . . .   | 2-6 |
|                     | Conduit . . . . .   | 2-8 |
|                     | Electrical . . . . .  | 2-8 |
| <b>SECTION 3</b>    | Overview . . . . .  | 3-1 |
| <b>Calibration</b>  | Calibration . . . . .   | 3-1 |
|                     | Span Adjustment . . . . .   | 3-1 |
|                     | Zero Adjustment . . . . .   | 3-1 |
|                     | Calibration Procedures . . . . .  | 3-2 |
|                     | Zero and Span Adjustment . . . . .  | 3-2 |
|                     | Linearity Adjustment . . . . .  | 3-4 |
|                     | Damping Adjustment . . . . .  | 3-5 |
|                     | Correction For High Line Pressure<br>(Rosemount 1154DP and 1154HP Only) . . . . . | 3-6 |
|                     | Span . . . . .  | 3-6 |
|                     | Zero . . . . .  | 3-7 |
| <b>SECTION 4</b>    | Overview . . . . .  | 4-1 |
| <b>Operation</b>    | Transmitter Operation . . . . .   | 4-1 |
|                     | The $\delta$ -Cell™ Sensor . . . . .  | 4-3 |
|                     | Demodulator . . . . .   | 4-3 |
|                     | Linearity Adjustment . . . . .  | 4-3 |
|                     | Oscillator . . . . .  | 4-4 |
|                     | Voltage Regulator . . . . .   | 4-4 |
|                     | Zero and Span Adjustments . . . . .   | 4-4 |
|                     | Current Control . . . . .   | 4-4 |
|                     | Current Limit . . . . .   | 4-4 |
|                     | Reverse Polarity Protection . . . . .   | 4-4 |

# Rosemount 1154

---

## **SECTION 5 Maintenance and Troubleshooting**

|  |     |
|--|-----|
| Overview . . . . .   | 5-1 |
| Safety Messages . . . . .  | 5-2 |
| Test Terminals . . . . .   | 5-2 |
| Board Checkout . . . . .   | 5-2 |
| Sensing Module Checkout . . . . .                                | 5-3 |
| Disassembly Procedure . . . . .                                  | 5-4 |
| Process Flange Removal . . . . .                                 | 5-4 |
| Electrical Housing Disassembly . . . . .                         | 5-6 |
| Removing Sensor Module from Electrical Housing . . . . .         | 5-6 |
| Reassembly Procedure . . . . .                                   | 5-6 |
| Preliminary . . . . .  | 5-7 |
| Connecting the Electrical Housing to the Sensor Module . . . . . | 5-7 |
| Electrical Housing Reassembly . . . . .                          | 5-7 |
| Process Flange Reassembly . . . . .                              | 5-8 |
| Post Assembly Tests . . . . .                                    | 5-9 |

## **SECTION 6 Specifications and Reference Data**

|   |     |
|---|-----|
| Nuclear Specifications . . . . .                  | 6-1 |
| Radiation . . . . .                               | 6-1 |
| Seismic . . . . .                                 | 6-1 |
| Steam Pressure/Temperature . . . . .              | 6-1 |
| Chemical Spray . . . . .                          | 6-1 |
| Post DBE Operation . . . . .                      | 6-2 |
| Quality Assurance Program . . . . .               | 6-2 |
| Nuclear Cleaning . . . . .                        | 6-2 |
| Hydrostatic Testing . . . . .                     | 6-2 |
| Traceability . . . . .                            | 6-2 |
| Qualified Life . . . . .                          | 6-2 |
| Performance Specifications . . . . .              | 6-2 |
| Accuracy . . . . .                                | 6-2 |
| Dead Band . . . . .                               | 6-2 |
| Drift . . . . .                                   | 6-3 |
| Temperature Effect . . . . .                      | 6-3 |
| Overpressure Effect . . . . .                     | 6-3 |
| Static Pressure Zero Effect . . . . .             | 6-4 |
| Static Pressure Span Effect . . . . .             | 6-4 |
| Power Supply Effect . . . . .                     | 6-4 |
| Load Effect . . . . .                             | 6-4 |
| Mounting Position Effect . . . . .                | 6-4 |
| Response Time . . . . .                           | 6-4 |
| Functional Specifications . . . . .               | 6-4 |
| Service . . . . .                                 | 6-4 |
| Output . . . . .                                  | 6-4 |
| Power Supply . . . . .                            | 6-4 |
| Span and Zero . . . . .                           | 6-5 |
| Zero Elevation and Suppression . . . . .          | 6-5 |
| Temperature Limits . . . . .                      | 6-5 |
| Humidity Limits . . . . .                         | 6-5 |
| Volumetric Displacement . . . . .                 | 6-5 |
| Turn-on Time . . . . .                            | 6-5 |
| Pressure Ranges . . . . .                         | 6-5 |
| Maximum Working Pressure . . . . .                | 6-5 |
| Static Pressure and Overpressure Limits . . . . . | 6-6 |
| Overpressure Limits . . . . .                     | 6-6 |



|                                |      |
|--------------------------------|------|
| Physical Specifications .....  | 6-6  |
| Materials of Construction..... | 6-6  |
| Electrical Connections.....    | 6-7  |
| Process Connections .....      | 6-7  |
| Weight.....                    | 6-7  |
| Ordering Information .....     | 6-8  |
| Spare Parts Shelf Life .....   | 6-11 |
| Important Notice .....         | 6-11 |
| NOTES:.....                    | 6-11 |



# Section 1 Introduction

## OVERVIEW

This manual is designed to assist in installing, operating, and maintaining the Rosemount 1154 Pressure Transmitter. The manual is organized into the following sections:

### Section 2: Installation

Provides general, mechanical, and electrical installation considerations to guide you through a safe and effective transmitter installation.

### Section 3: Calibration

Provides transmitter calibration procedures.

### Section 4: Operation

Provides descriptions of how the transmitter operates.

### Section 5: Maintenance and Troubleshooting

Provides basic hardware troubleshooting considerations including sensing module checkout, disassembly and reassembly procedures, and post-assembly tests.

### Section 6: Specifications and Reference Data

Provides nuclear, performance, functional, and physical transmitter specifications; also includes ordering information, and a list of spare parts.

## ABOUT THE TRANSMITTER

Rosemount 1154 Pressure Transmitters are designed for precision pressure measurements in nuclear applications requiring reliable performance and safety over a specified qualified life. These transmitters were generically tested to the IEEE Std 323-1974 and IEEE Std 344-1975 per the Qualification Test Report D8400102. The Rosemount 1154 has been qualification tested to environments typical of Pressurized Water Reactors (PWR) under accident conditions. Stringent quality control during the manufacturing process includes traceability of pressure retaining parts, special nuclear cleaning, and hydrostatic testing.

Rosemount 1154 Transmitters are uniquely built to Class 1E nuclear service while retaining the working concept and design parameters of the Rosemount 1151 Series that have become a standard of reliable service. Units are available in gage (G), differential (D), and high-line differential (H) configurations, with a variety of pressure range options, as shown in Table 6-1 on page 6-8. Figure 2-5 on page 2-7 shows dimensional drawings for the transmitters.



---

## Section 2 Installation

---

|                                 |          |
|---------------------------------|----------|
| Overview .....                  | page 2-1 |
| General Considerations .....    | page 2-1 |
| Mechanical Considerations ..... | page 2-2 |
| Electrical Considerations ..... | page 2-4 |
| Installation Procedures .....   | page 2-6 |

---

### OVERVIEW

This section contains information and instructions regarding the following installation-related information:

- General Considerations
- Mechanical Considerations
  - Process Connections
  - Conduit
- Electrical Considerations
- Installation Procedures
  - Mechanical
  - Electrical

### GENERAL CONSIDERATIONS

The quality and accuracy of flow, level, or pressure measurement depends largely on the proper installation of the transmitter and its associated impulse piping and valves. For flow measurement, proper installation of the primary measuring element is also critical to the accuracy of the measurement. Transmitter installation should minimize the effects of temperature gradients and temperature fluctuations, and avoid vibration and shock during normal operation. Take care when designing the measurement to minimize the error caused by incorrect installation. The ambient temperature of the transmitter environment affects the qualified life of the transmitter (see Figure 2-1).

Figure 2-1. Qualified Life vs. Ambient Temperature.

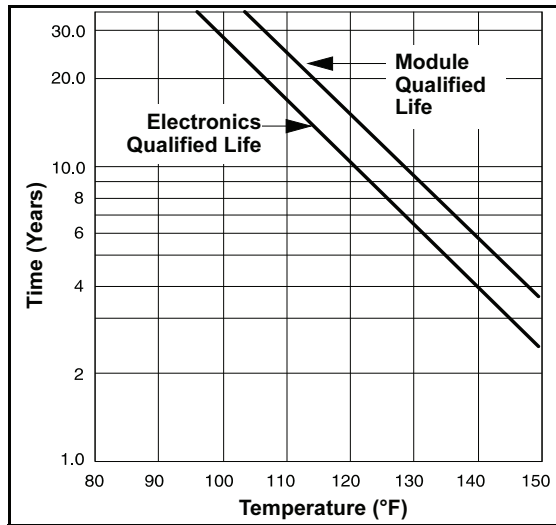

## MECHANICAL CONSIDERATIONS

This section contains information you should consider when preparing to mount the transmitter. Read this section carefully before proceeding to the mechanical installation procedure.

Mount the Rosemount 1154 transmitter to a rigid support (a support with a fundamental mechanical resonant frequency of 40 Hz or greater). A mounting bracket included with the transmitter facilitates panel mounting. Figure 2-4 on page 2-6 shows the qualified mounting configurations. The transmitter was seismic qualified with the bracket mounted with four  $\frac{3}{8}$ -in. diameter bolts. Orientation with respect to gravity is not critical to qualification. However, if the transmitter is mounted with the flanges in a horizontal position, zero the transmitter to cancel the liquid head effect caused by the difference in height of the process connections.

If the transmitter is mounted to a non-rigid panel, the user must ensure that seismic input to the mounting bracket does not exceed qualification levels given in Rosemount Report D8400102.

## Process Connections

Process tubing installation must prevent any added mechanical stress on the transmitter under seismic disturbances. This may be done by using stress-relief loops in the process tubing or by separately supporting the process tubing close to the transmitter.

The process connections to the transmitter flanges were qualified with  $\frac{3}{8}$ -in. tubing using Swagelok® compression fittings. For options using  $\frac{1}{4}$ -18 NPT connections, the user assumes responsibility for qualifying the interface.

The Swagelok tube fittings are shipped completely assembled for immediate use. **Do not disassemble them before use;** doing so may contaminate the fittings and result in leaks. Insert the tubing into the Swagelok tube fitting, making sure that the tubing rests firmly on the shoulder of the fitting and that the nut is finger tight. Tighten the nut one-and-one-quarter turns past finger tight to prepare the transmitter for use. **Do not overtighten.**

Transmitters with Flange Options A, D, H, J, L, or M are shipped with Swagelok fittings for process connections. Included are front ferrule, rear ferrule, and nut. Ensure that the fittings are placed on the tubing with the orientation and relative position shown in Detail A, Figure 2-5 on page 2-7. Process tubing used is  $\frac{3}{8}$ -inch outside diameter, and of suitable thickness for the pressure involved.

The connections can be loosened and re-tightened 20-30 times without compromising the leak proof seal. To reconnect, insert the tubing with pre-swaged ferrules into the fitting until the front ferrule sits in the fitting. Tighten the nut by hand, then rotate one-quarter turn more or to the original one-and-one-quarter tight position. Then snug the nut slightly with a wrench. For more information regarding the use of Swagelok tube fittings, refer to:

Fittings Catalog MS-01-140  
“Gaugable Tube Fittings and Adapter Fittings”  
[www.swagelok.com](http://www.swagelok.com)

If the drain/vent valves must be opened to bleed process lines, torque them to 7.5 ft-lb (10 N-m) when closing.

Proper location of the transmitter with respect to the process tubing depends on various process parameters. When determining the best location, consider the following:

- Keep hot or corrosive fluids from contacting the transmitter.
- Prevent sediment from depositing in the impulse tubing.
- Ambient temperature gradients and fluctuations can result in erroneous transmitter readings.
- Keep impulse tubing as short as possible.
- For differential transmitters, balance the liquid head on both legs of the impulse tubing.
- For liquid flow or pressure measurements, make taps on the side of the line to avoid sediment deposits, and mount the transmitter beside or below the taps so gases vent into the process line (see Figure 2-6 on page 2-8).
- For gas flow or pressure measurements, make taps on the top or side of the line and mount the transmitter beside or above the taps so liquid drains into the process line (see Figure 2-6 on page 2-8).
- For steam flow or pressure measurements, make taps on the side of the line, and mount the transmitter below the taps so the impulse tubing stays filled with condensate (See Figure 2-6 on page 2-8).
- For steam service, fill the lines with water to prevent steam from contacting the transmitter. Condensate chambers are not necessary since the volumetric displacement of the transmitter is negligible.

The piping between the process and the transmitter must transfer the pressure measured at the process taps to the transmitter. Possible sources of error in this pressure transfer are:

- Leaks
- Friction loss (particularly if purging is used)
- Trapped gas in a liquid line or trapped liquid in a gas line (head error)
- Temperature-induced density variation between legs (head error), for differential transmitters

To minimize the possibility of errors, take the following precautions:

- Make impulse tubing as short as possible.
- Slope tubing at least one inch per foot up toward the process connections for liquid and steam.
- Slope tubing at least one inch per foot down toward the process connections for gas.
- Avoid high points in liquid lines and low points in gas lines.
- Use impulse tubing of sufficient diameter to avoid friction effects.
- Ensure that all gas is vented from liquid tubing legs.
- Ensure that impulse tubing is of adequate strength to be compatible with anticipated pressures.

For differential transmitters, also consider the following:

- Keep both impulse legs at the same temperature.
- When using sealing fluid, fill both piping legs to the same level.
- When purging, make the purge connection close to the process taps and purge through equal lengths of the same size tubing. Avoid purging through the transmitter.

## Conduit

The conduit connection to the transmitter is  $\frac{1}{2}$ –14 NPT. Use a qualified conduit seal at the conduit entry to prevent moisture from accumulating in the terminal side of the housing during accident conditions. To prevent the conduit from adding mechanical stress to the transmitter during seismic disturbances, use flexible conduit or support the conduit near the transmitter. Install the conduit seal in accordance with the manufacturer's instructions or use the procedure on page 2-8.

## ELECTRICAL CONSIDERATIONS

This section contains information that you should consider when preparing to make electrical connections to the transmitter. Read this section carefully before proceeding to the electrical installation procedures.

The Rosemount 1154 pressure transmitter provides a 4–20 mA signal when connected to a suitable dc power source. Figure 2-2 on page 2-5 shows a typical signal loop consisting of transmitter, power supply, and various receivers (controller, indicator, computer, etc.). The power supply must supply at least 12 volts to the transmitter terminals at 30 mA (overscale) signal, or the maximum output current required for proper system operation. Any power supply ripple appears in the output load. The supply voltage versus load limitation relationship is shown in Figure 2-3 on page 2-5. See qualification report D8400102 for details. The load is the sum of the resistance of the signal leads and the load resistance of the receivers.



Signal wiring need not be shielded, but twisted pairs yield the best results. In electrically noisy environments, shielded cable should be used for best results. Do not run signal wiring in conduit or open trays with power wiring, or near heavy electrical equipment. Signal wiring may be ungrounded (floating) or grounded at any place in the signal loop. The transmitter case may be grounded or ungrounded.

The capacitance-sensing element uses alternating current to generate a capacitance signal. This alternating current is developed in an oscillator circuit with a frequency of  $32,000 \pm 10,000$  Hz. This 32,000 Hz signal is capacitor coupled to transmitter case ground through the sensing element. Because of this coupling, a voltage may be imposed across the load, depending on choice of grounding.

The impressed voltage, which is seen as high frequency noise, has no effect on most instruments. Computers with short sampling times in a circuit where the negative transmitter terminal is grounded will detect a significant noise signal. Filter this noise with a large capacitor ( $1 \mu\text{f}$ ) or by using a 32,000 Hz LC filter across the load. Signal loops grounded at any other point are negligibly affected by this noise and do not need filtering.

Figure 2-2. Transmitter Wiring Connections.

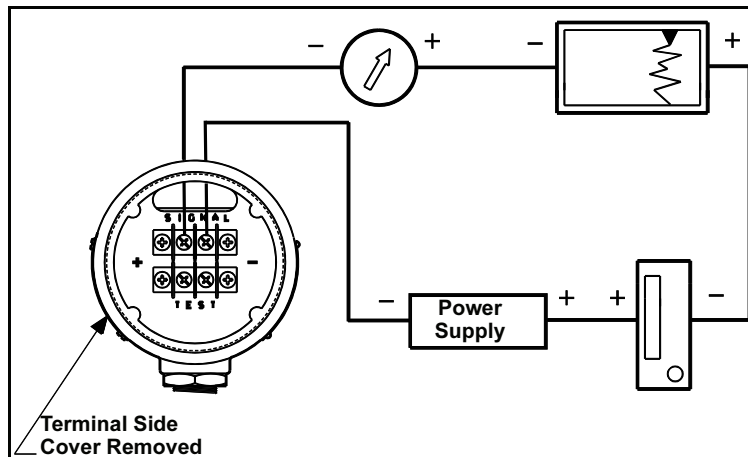
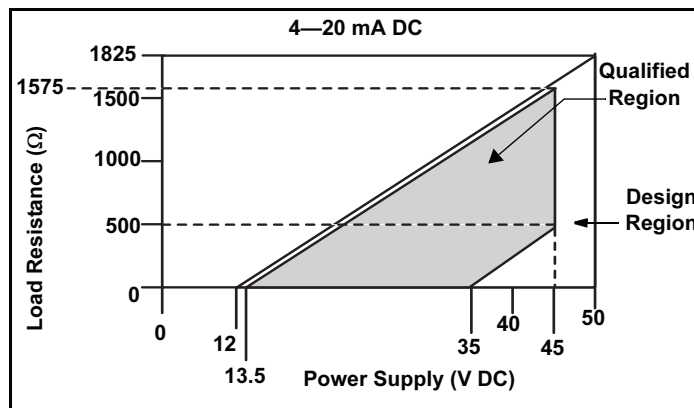

Figure 2-3. Supply Voltage vs. Load.



## INSTALLATION PROCEDURES

Installation consists of mounting the transmitter and conduit and making electrical connections. Procedures follow for each operation.

### Mechanical

#### Transmitter

#### ⚠ CAUTION

Be careful not to break the neck seal between the sensor module and the electronics housing.

The threaded interface between the sensor module and the electronics housing is hermetically sealed before shipment. The integrity of this seal is necessary for the safe operation of the transmitter during accident conditions. If the seal is broken, reseal it according to "Connecting the Electrical Housing to the Sensor Module" on page 5-7.

1. Mount the bracket to a panel or other flat surface as shown in Figure 2-4. Use four  $\frac{3}{8}$ -in. diameter bolts (not supplied with unit). SAE grade 2 bolts were used during qualification testing. Torque each bolt to 19 ft-lb (26 N-m).
2. Attach the transmitter to the mounting bracket, as shown in Figure 2-4. Use four  $\frac{7}{16}$ -20  $\times$   $\frac{3}{4}$  bolts with washers (supplied with unit). Torque each bolt to 21 ft-lb (29 N-m).

Figure 2-4. Typical Transmitter Mounting Bracket Configuration.

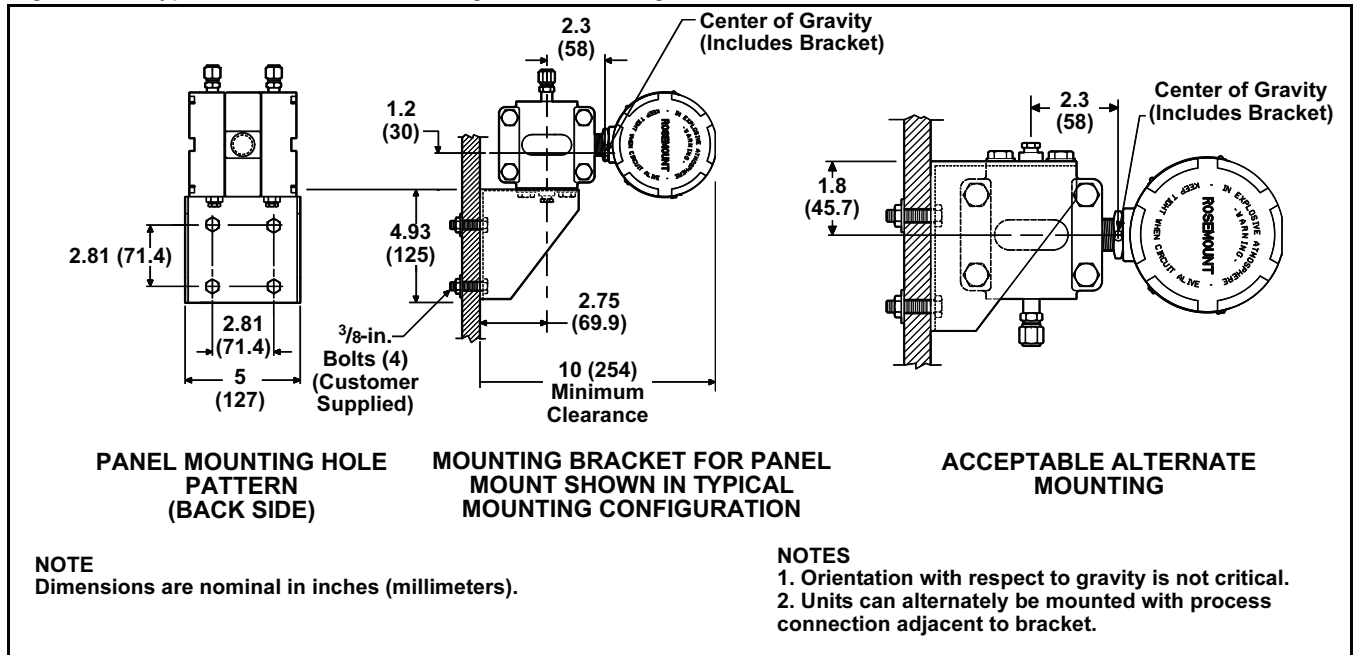
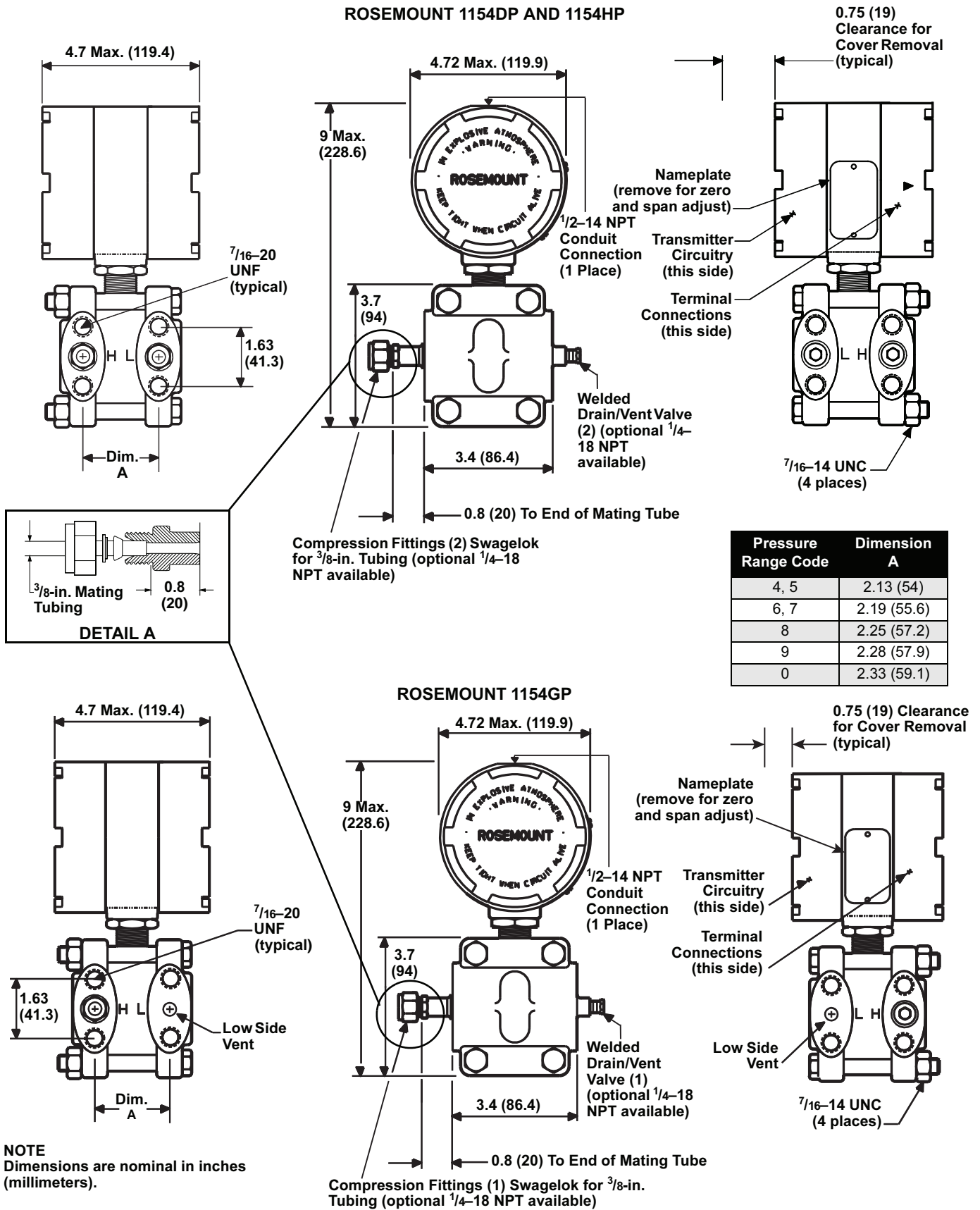

Figure 2-5. Transmitter Dimensional Drawings.



### Conduit

1. Seal the conduit threads with thread sealant. (The transmitter conduit seal interface was qualified using Grafoil™ tape.) Conduit threads mate with a standard 1/2–14 NPT male fitting.
2. Starting at zero thread engagement, install the conduit into the transmitter between 4 and 7 turns, or a minimum of 12.5 ft-lb (16.9 N-m). Hold the electronics housing securely to avoid damaging the threaded neck seal between the sensor module and the electronics housing during conduit installation.
3. Provide separate support for the conduit if necessary.

Figure 2-6. Transmitter Installation Configuration.

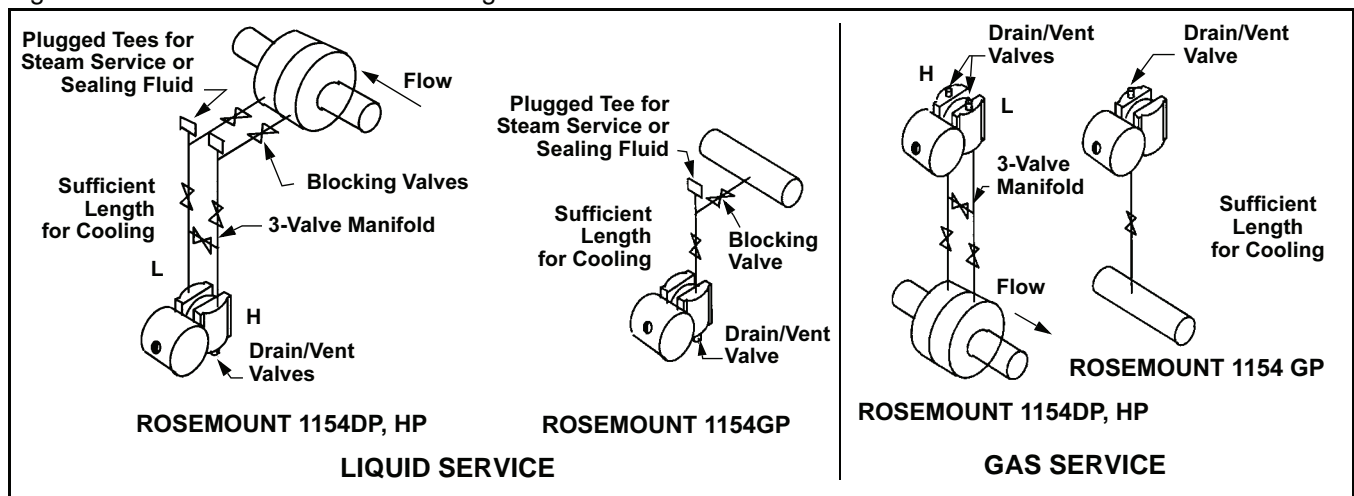

### Electrical

1. Remove the cover from the terminal side of the transmitter (see Figure 2-5 on page 2-7).
2. Connect the power leads to the “SIGNAL” terminals on the transmitter terminal block (see Figure 2-7 on page 2-9). Torque the terminal screws to 5 in-lb (0.6 N-m), or hand-tight.

### NOTE

Do not connect signal leads to the “TEST” terminals.

3. Recheck connections for proper polarity.
4. Check the cover O-ring grooves for cleanliness. If chips or dirt are present, clean the seat and mating portion of the cover with alcohol. Lubricate replacement O-ring with O-ring grease (RMT P/N 01153-0248-0001 or P/N 01153-0053-0001). The transmitter was qualified using Dow Corning® 55 Silicone O-ring Grease.
5. Spray the inside threads of the electronics covers with cover lubricant (Rosemount P/N 01153-0333-0001 or equivalent) if necessary; if covers are already sufficiently lubricated, do not spray.
6. Carefully replace cover and tighten to 16.5 ft-lb (22.4 N-m).

Figure 2-7. Transmitter Terminal Block.

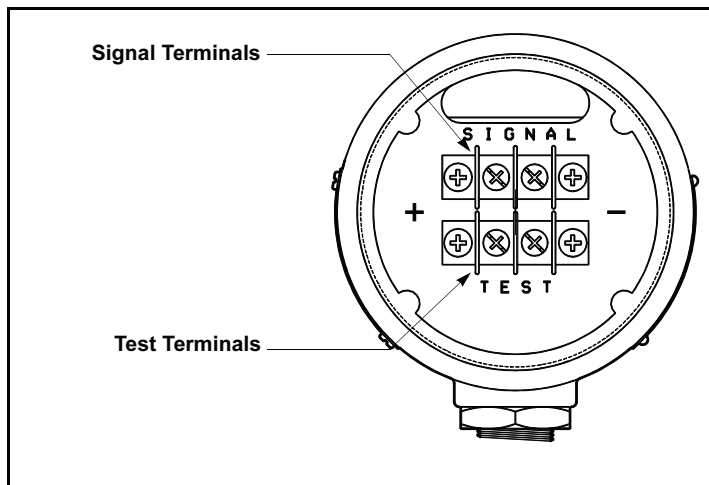



# Section 3 Calibration

---

|                              |          |
|------------------------------|----------|
| Overview .....               | page 3-1 |
| Calibration .....            | page 3-1 |
| Calibration Procedures ..... | page 3-2 |

---

## OVERVIEW

Each transmitter is factory calibrated to the range specified by the customer.

This section contains the following transmitter calibration information:

- Calibration
  - Span Adjustment
  - Zero Adjustment
- Calibration Procedures
  - Zero and Span Adjustment
  - Linearity Adjustment
  - Damping Adjustment
  - Correction for High Line Pressure

## CALIBRATION

The Rosemount 1154DP, HP, and GP transmitters are factory calibrated to the range shown on the nameplate. This range may be changed within the limits of the transmitter. Zero may also be adjusted to elevate or to suppress. The span and zero adjustments are external and located under the nameplate.

### Span Adjustment

The span on any Rosemount 1154 transmitter is continuously adjustable to allow calibration anywhere between maximum span and  $\frac{1}{6}$  of maximum span ( $\frac{1}{4}$  of maximum span for Range Code 0). For example, the span on a Range Code 4 transmitter can be continuously adjusted between 0–150 and 0–25 inH<sub>2</sub>O.

### Zero Adjustment

The zero can be adjusted for up to 500 percent of span suppression (300 percent for Range Code 0) or 600 percent of span elevation (400 percent for Range Code 0) (see Figure 3-1 on page 3-2).

The zero may be elevated or suppressed to these extremes with the limitation that no applied pressure within the calibrated range exceeds the full-range pressure limit. For example, a Range Code 4 transmitter cannot be calibrated for 150 to 200 inH<sub>2</sub>O (only 300 percent zero suppression) because the 200 inH<sub>2</sub>O exceeds the 150 inH<sub>2</sub>O upper range pressure limit of a Range Code 4.

The transmitter may be calibrated to cross zero, (e.g., –75 to 75 inH<sub>2</sub>O) but this may result in a slight loss of linearity.

Figure 3-1. Zero Adjustment Range.

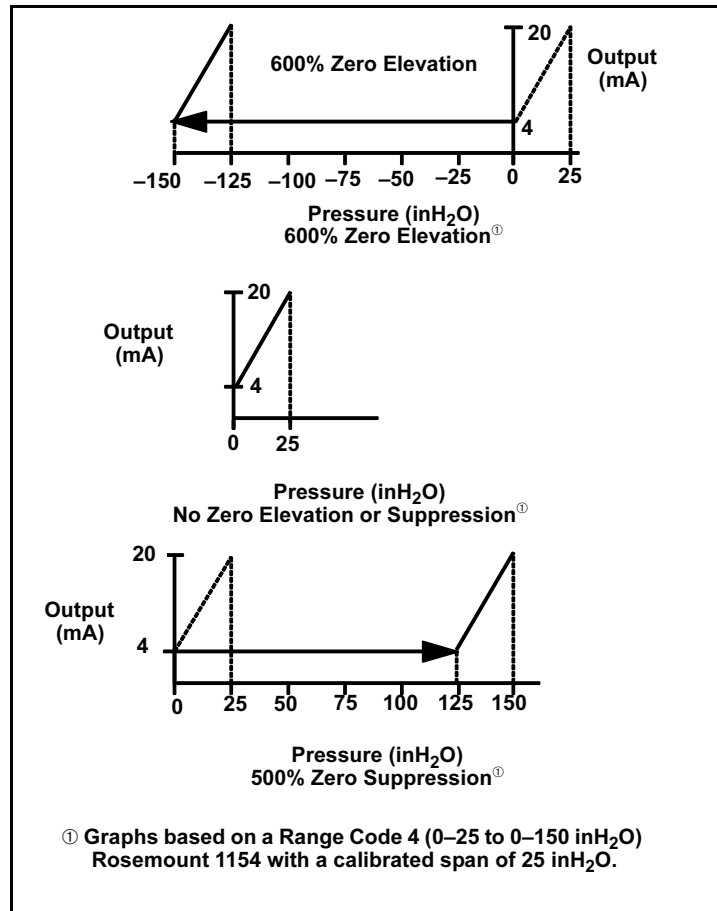

## CALIBRATION PROCEDURES

### Zero and Span Adjustment

#### NOTE

The Rosemount 1154 Pressure Transmitter contains electronic circuit boards which may be static sensitive.

#### NOTE

Covers need not be removed for zero and span adjustment.

The zero and span adjustment screws are accessible externally. They are located behind the nameplate on the side of the electronics housing (see Figure 3-2 on page 3-3). The transmitter output increases with clockwise rotation of the adjustment screws.

The zero adjustment screw has very little effect on the span. The span adjustment, however, does affect the zero. The effect of interaction is more apparent with suppression or elevation. The span adjustment changes the zero output and the full-scale output by approximately the same percentage. Therefore, it is best to calibrate the transmitter from zero to the desired span and finish the calibration by adjusting the zero screw to achieve the desired elevation or suppression.



Figure 3-2. Zero and Span Adjustment Screws.

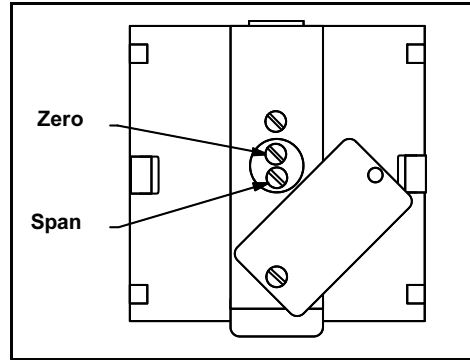

**Example (for Range Code 4)**

Initial transmitter calibration: 25 to 125 inH<sub>2</sub>O  
 (100 inH<sub>2</sub>O span with zero suppressed 25 inH<sub>2</sub>O)

Desired transmitter calibration: -75 to -25 inH<sub>2</sub>O  
 (50 inH<sub>2</sub>O span with zero elevated 75 inH<sub>2</sub>O)

1. Adjust the zero to eliminate any existing zero elevation or suppression. With 0 inH<sub>2</sub>O pressure applied to the transmitter, turn the zero adjustment until the output reads 4 mA. The unit is now calibrated for 0 to 100 inH<sub>2</sub>O.
2. Adjust the span to the desired new span. To reduce the span, turn the span screw until the output, with 0 inH<sub>2</sub>O pressure input, equals:

$$4 \text{ mA} \times \frac{\text{Existing Span}}{\text{Desired Span}} = 4 \text{ mA} \times \frac{100 \text{ inH}_2\text{O}}{50 \text{ inH}_2\text{O}} = 8 \text{ mA}$$

3. Adjust the zero screw to bring the output, with 0 inH<sub>2</sub>O input, back to 4 mA. The transmitter calibration should now be very close to 0 to 50 inH<sub>2</sub>O.
4. Check full-scale output and fine tune the span and zero adjustment if required. Remember zero adjustments do not affect span, but span adjustments do affect zero predictably. Adjusting the span screw affects the zero 1/5 as much as it affects the span. To compensate for this effect, simply overadjust by 25 percent.

For example, if, after completing step 3, the transmitter output reads 19.900 mA at 50 inH<sub>2</sub>O, turn the span potentiometer until the output (at 50 inH<sub>2</sub>O) reads 20.025 mA.

$$19.900 + (20.000 - 19.900) \times 1.25 = 19.900 + 0.125 = 20.025$$

Since the span adjustment affects zero 1/5 as much as the span, the 0.125 mA increase in span causes a 0.025 mA increase in zero. Therefore, turn the zero adjustment (at 50 inH<sub>2</sub>O) until the output reads 20.000 mA. The unit should now be calibrated for 0 to 50 inH<sub>2</sub>O.

5. Zero Elevation/Suppression. Elevate zero. Turn the screw until the output reads 4 mA with -75 inH<sub>2</sub>O applied to the high side of the transmitter (applying 75 inH<sub>2</sub>O to the low side of the transmitter will give the same result). The output may stop changing before the desired 4 mA reading is obtained. If this occurs, turn off power to the unit and unplug the amplifier board (refer to "Electrical Housing Disassembly" on page 5-6 and Table 5-1 on page 5-5). To elevate or suppress zero a large amount, use the following procedure:

**Material**

- Wire: 22-gauge tinned solid copper – Fed Spec QQW343, ASTM B33
- Solder: 60% tin, 40% lead (60/40) – Fed Spec QQ-S-571
- Flux: MIL F 14256, Type A, Fed Spec QQ-S-571 Type RA

**Method**

- a. Locate the three turret terminals on the component side of the amplifier board. Remove any jumper wires between them (see Figure 3-3).
- b. To elevate zero, connect a jumper wire between the middle terminal and the terminal marked “EZ” (see Figure 3-3, Detail B).
- c. Wrap the jumper wire once around each terminal and cut off any excess.
- d. Solder the jumper wire to the terminals using proper electronics soldering techniques. Clean solder joints thoroughly with isopropyl alcohol.
- e. Plug the amplifier board back in and complete the zero adjustment.

To suppress zero, follow the same procedure, except connect the jumper wire between the middle terminal and the terminal marked “SZ” (see Figure 3-3, Detail C).

6. Recheck full scale and zero and fine tune if necessary.

**NOTE**

There is some mechanical backlash in the zero and span adjustments, so there is a dead band when you change the direction of adjustment. Because of the backlash, the simplest procedure, if the desired setting is overshoot, is to intentionally overshoot a larger amount before reversing the direction of the adjustment.

Figure 3-3. Jumper Wire Placement.

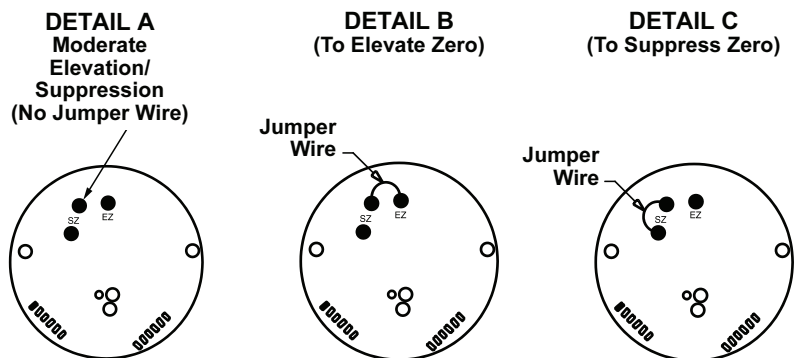

**Linearity Adjustment**

In addition to the span and zero adjustments, there is a linearity adjustment located inside the transmitter on the amplifier board (see Figure 3-4 on page 3-5). Linearity is factory calibrated for optimum performance over the calibrated range of the instrument and is not normally adjusted in the field. If you want to maximize linearity over some particular range, use the following procedure:

1. Apply mid-range pressure and note the error between theoretical and actual output signal.
2. Apply full-scale pressure. Multiply the error noted in step 1 by six and by the rangedown factor:

$$\text{Rangedown Factor} = \frac{\text{Maximum Allowable Span}}{\text{Calibrated Span}}$$

3. Add the result to the full-scale output for negative errors, or subtract the result from the full-scale output for positive errors by adjusting the linearity trimmer (see Figure 3-4). Example: At 4-to-1 rangedown the midscale point is low by 0.05 mA. Therefore, adjust the "Linearity" trimmer until full-scale output increases by  $(0.05 \text{ mA} \times 6 \times 4) = 1.2 \text{ mA}$ .
4. Readjust zero and span.

**NOTE**

If you remove either cover during the above procedures, replace the O-ring and torque the cover per the instructions given in **Section 5 Maintenance and Troubleshooting**. Spare cover O-rings are supplied with each transmitter.

Figure 3-4. Linearity and Damping Adjustment.

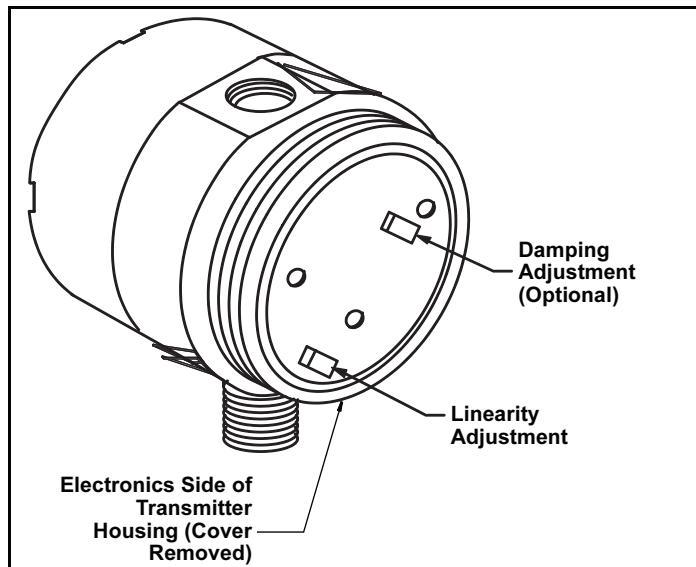

**Damping Adjustment**

Damping electronics are available as an option. Transmitters with standard electronics can be retrofitted with the adjustable damping feature by changing out both the amplifier board (RMT P/N 01154-0021-0004) and the calibration board (RMT P/N 01154-0023-0002).

The damping adjustment permits damping of rapid pressure variations by adjusting the single-turn trim potentiometer located on the upper right-hand side of the amplifier board (see Figure 3-4). The available settings, when adjusted to the maximum position, provide time-constant values of at least 1.2 seconds for Range Code 4 and 0.8 seconds for Range Codes 5–9 and 0. Transmitters with the electronic damping option are calibrated and shipped with the adjustment set at the counterclockwise stop, giving the minimum time-constant.

To adjust the damping, turn the damping adjustment potentiometer until the desired time-constant is obtained. It is best to set the damping to the shortest possible time-constant. Since transmitter calibration is not affected by the damping setting, you may adjust the damping with the transmitter installed on the process.

**⚠ CAUTION**

The damping adjustment potentiometer has positive stops at both ends. Forcing the potentiometer beyond the stops may cause permanent damage.

**NOTE**

If you remove either cover during the above procedures, replace the O-ring and torque the cover per the instructions given in **Section 5 Maintenance and Troubleshooting** of this manual. Spare cover O-rings are supplied with each transmitter.

**Correction For High Line Pressure (Rosemount 1154DP and 1154HP Only)**

**Span**

If a differential transmitter is calibrated with the low side at ambient pressure but will be used at high line pressure, correct the span adjustment to compensate for the effect of static pressure on the unit. If zero is elevated or suppressed, also correct the zero adjustment. Correction factors, expressed in percent of differential pressure input at end points per 1,000 psi static pressure, are:

**Range Codes 4, 5, and 8:**

+0.75% of input/1,000 psi

**Range Codes 6 and 7:**

+1.25% of input/1,000 psi

The correction procedure below uses the following example:

Range Code 5, calibrated at –100 to 300 inH<sub>2</sub>O, to be operated at 1,200 psi line pressure. Note that steps 3–6 are omitted for ranges based at zero differential pressure.

1. Calibrate the unit per preceding section to output = 4 mA at -100 inH<sub>2</sub>O and 20 mA at 300 inH<sub>2</sub>O.
2. Calculate correction factor:  
$$\frac{0.75 \%}{1,000 \text{ psi}} \times 1, 200 \text{ psi} = 0.9\% \text{ differential input}$$
3. Calculate zero adjustment correction in terms of pressure:  
$$0.9 \% \times -100 \text{ inH}_2\text{O} = -0.9 \text{ inH}_2\text{O}$$
4. Convert pressure correction to percent of input span:  
$$\frac{-0.9 \text{ inH}_2\text{O}}{400 \text{ inH}_2\text{O input span}} = -0.225 \% \text{ span}$$
5. Calculate correction in terms of output span (mA):  
$$-0.225 \% \times 16 \text{ mA span} = -0.036 \text{ mA}$$
6. Add the milliamp correction to the ideal zero output (4 mA). This is the corrected ideal zero output:  
$$4.00 \text{ mA} - 0.036 = 3.964 \text{ mA}$$
7. Calculate full-scale adjustment correction in terms of pressure:  
$$0.9 \% \times 300 \text{ inH}_2\text{O} = 2.7 \text{ inH}_2\text{O}$$
8. Repeat step 4 with the results of step 7:  
$$\frac{2.7 \text{ inH}_2\text{O}}{400 \text{ inH}_2\text{O input span}} = 0.675 \% \text{ span}$$
9. Repeat step 5 with the result of step 8:  
$$0.675 \% \times 16 \text{ mA span} = 0.108 \text{ mA}$$
10. Add the mA correction to the ideal full-scale output (20 mA). This is the corrected ideal full-scale output:  
$$20.00 \text{ mA} + 0.108 \text{ mA} = 20.108 \text{ mA}$$
11. Readjust zero and span adjustments for corrected outputs:  
3.964 mA at -100 inH<sub>2</sub>O  
20.108 mA at 300 inH<sub>2</sub>O

There is an uncertainty of ±0.5 percent of input reading per 1,000 psi associated with the span correction.

### Zero

Zero shift with static pressure is not systematic. However, if the calibrated range includes zero differential pressure, the effect can be trimmed out after installation and with the unit at operating pressure.

Equalize pressure to both process connections, and turn the zero adjustment until the ideal output at zero differential input is observed. Do not readjust the span potentiometer.

If the transmitter does not include zero differential pressure within its calibrated span, the zero effect or zero correction can be determined before the unit is suppressed or elevated to eliminate the zero effect after correcting for the span effect.

The following procedure illustrates how to eliminate the zero effect for a non-zero differential pressure calibration. The example uses a Range Code 5, calibrated from 100 to 500 inH<sub>2</sub>O, with 1,200 psi static line pressure.

1. Using standard calibration procedures, calibrate the unit to the required span, with the 4 mA or zero point corresponding to zero differential pressure:

4 mA at 0 inH<sub>2</sub>O and 20 mA at 400 inH<sub>2</sub>O

2. Apply static pressure to both high and low process connections with zero differential pressure across the transmitter, and note the zero correction (zero shift). For example, if the output reads 4.006 mA, the zero correction is calculated as:

$$4.00 \text{ mA} - 4.006 \text{ mA} = -0.006 \text{ mA}$$

Note the sign associated with this correction, as this result is added when determining the final, ideal transmitter output.

3. Remove static pressure and correct for the span effect as outlined in the span correction procedure. Calibrate the unit to the calculated output values. If, for example, the span correction procedure yielded 4.029 mA and 20.144 mA, calibrate the unit for:

4.029 mA at 100 inH<sub>2</sub>O  
20.144 mA at 500 inH<sub>2</sub>O

4. Add the zero correction (-0.006 mA), found in step 2, to the ideal zero point value calculated in step 3.

$$4.029 \text{ mA} + (-0.006 \text{ mA}) = 4.023 \text{ mA}$$

5. To eliminate the zero effect, readjust the zero potentiometer so the output reads the ideal zero point calculated in step 4 (do not readjust the span potentiometer). Note that all the calibration points will shift the same amount toward the correct reading. The example output is now 4.023 mA at 100 inH<sub>2</sub>O.

The transmitter output is now 4–20 mA over its calibrated span when the unit is operated at 1,200 psi static line pressure.

# Section 4      Operation

---

|                                   |          |
|-----------------------------------|----------|
| Overview .....                    | page 4-1 |
| Transmitter Operation .....       | page 4-1 |
| The $\delta$ -Cell Sensor .....   | page 4-3 |
| Demodulator .....                 | page 4-3 |
| Linearity Adjustment .....        | page 4-3 |
| Oscillator .....                  | page 4-4 |
| Voltage Regulator .....           | page 4-4 |
| Zero and Span Adjustments .....   | page 4-4 |
| Current Control .....             | page 4-4 |
| Current Limit .....               | page 4-4 |
| Reverse Polarity Protection ..... | page 4-4 |

---

## OVERVIEW

This section provides brief descriptions of basic transmitter operations in the following order:

- Transmitter Operation
- The  $\delta$ -Cell™ Sensor
- Demodulator
- Linearity Adjustment
- Oscillator
- Voltage Regulator
- Zero and Span Adjustments
- Current Control
- Current Limit
- Reverse Polarity Protection

## TRANSMITTER OPERATION

The block diagram in Figure 4-2 on page 4-3 illustrates the operation of the transmitter.

The Rosemount 1154 Alphasine Pressure Transmitters have a variable capacitance sensing element, the  $\delta$ -Cell (Figure 4-1 on page 4-2). Differential capacitance between the sensing diaphragm and the capacitor plates is converted electronically to a 2-wire 4–20 mA dc signal.

$$P = K_1 \left( \frac{C_2 - C_1}{C_1 + C_2} \right)$$

Where:

P is the process pressure.

$K_1$  is a constant.

$C_1$  is the capacitance between the high pressure side and the sensing diaphragm.

$C_2$  is the capacitance between the low pressure side and the sensing diaphragm.

$$fV_{p-p} = \frac{I_{ref}}{C_1 + C_2}$$

Where:

$I_{ref}$  is the current source.

$V_{p-p}$  is the peak-to-peak oscillation voltage.

$f$  is the oscillation frequency.

$$I_{diff} = fV_{p-p}(C_2 - C_1)$$

Where:

$I_{diff}$  is the difference in current between  $C_1$  and  $C_2$ .

Therefore:

$$P = \text{Constant} \times I_{diff} = I_{ref} \left( \frac{C_2 - C_1}{C_2 + C_1} \right)$$

Figure 4-1. The  $\delta$ -Cell.

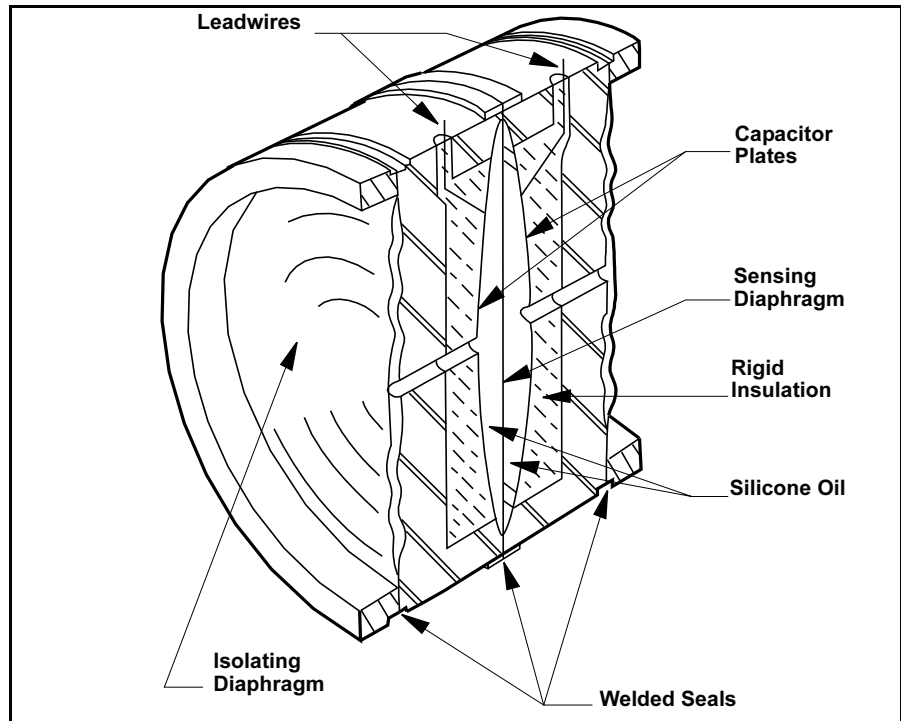
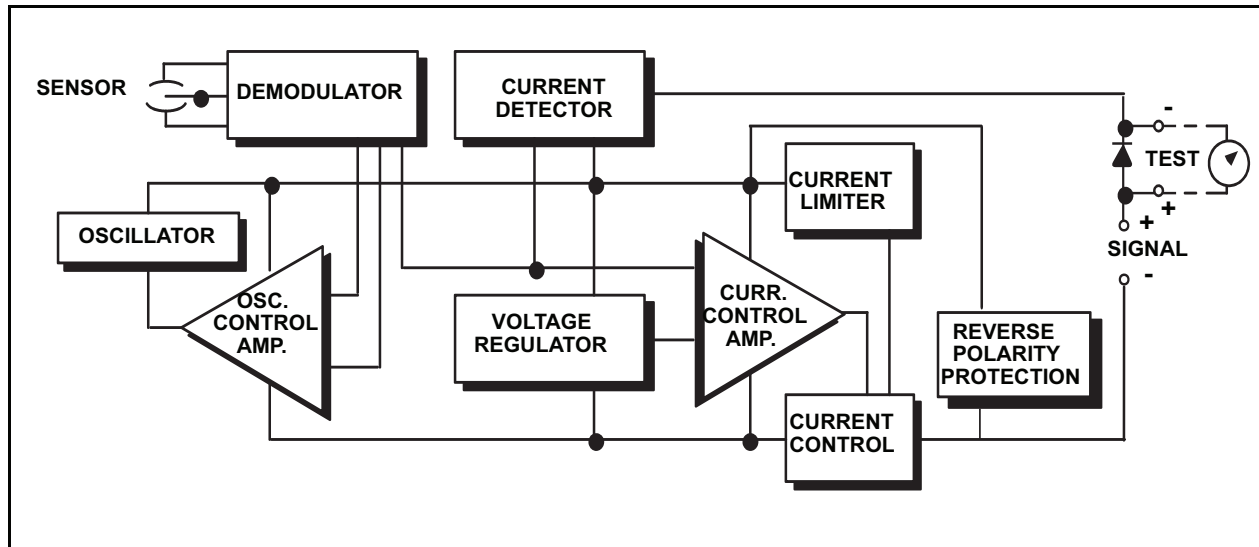



Figure 4-2. Electrical Block Diagram.



### THE $\delta$ -CELL™ SENSOR

Process pressure is transmitted through an isolating diaphragm and silicone oil fill fluid to a sensing diaphragm in the center of the  $\delta$ -Cell. The reference pressure is transmitted in like manner to the other side of the sensing diaphragm.

The position of the sensing diaphragm is detected by the capacitance plates on both sides of the sensing diaphragm. The capacitance between the sensing diaphragm and either capacitor plate is approximately 150 pf. The sensor is driven through transformer windings by an oscillator at roughly 32 kHz and 30 V<sub>p-p</sub>.

### DEMODULATOR

The demodulator consists of a diode bridge that rectifies the ac signal from the sensor cell to a dc signal.

The oscillator driving current,  $I_{ref}$  (the sum of the dc currents through two transformer windings) is controlled to be a constant by an integrated circuit amplifier.

The dc current through a third transformer winding is a current directly proportional to pressure, i.e.,

$$I_{diff} = fV_{p-p}(C_2 - C_1)$$

The diode bridge and span temperature compensating thermistor are located inside the sensor module. The effect of the thermistor is controlled by resistors located in the electronics housing.

### LINEARITY ADJUSTMENT

Linearity is adjusted by a variable-resistance network, capacitor, and diodes. The currents generated through this part of the circuit are summed into the inputs of the oscillator control circuit. This provides a programmed correction that raises the oscillator peak-to-peak voltage to compensate for first-order nonlinearity of capacitance as a function of pressure.

## OSCILLATOR

The oscillator has a frequency determined by the capacitance of the sensing element and the inductance of the transformer windings.

The sensing element capacitance is variable. Therefore, the frequency is variable about a nominal value of 32 kHz.

An integrated circuit amplifier is used as a feedback control circuit and controls the oscillator drive voltage such that:

$$fV_{p-p} = \frac{I_{ref}}{C_1 + C_2}$$

## VOLTAGE REGULATOR

The transmitter uses a zener diode, transistor, and resistors to provide a constant voltage of 6.4 V dc for the reference and 7 V dc for the oscillator.

## ZERO AND SPAN ADJUSTMENTS

Zero adjustment components consist of a potentiometer and resistor that develop a separate adjustable current that sums with the sensor current. The coarse zero switch switches resistors into the circuit as needed.

Span adjustment is performed with a potentiometer which determines the amount of loop current which is sensed and fed back to the current control amplifier.

## CURRENT CONTROL

The current control amplifier consists of an integrated circuit, two transistors, and associated components. The IC reference voltage is established at the junction of a resistor network. The current control amplifier drives the current control to a level such that the current detector feeds back a signal equal to the sum of the zero current and the variable sensor current.

## CURRENT LIMIT

A current limiter prevents the output current from exceeding 30 mA in an overpressure condition.

## REVERSE POLARITY PROTECTION

A zener diode provides reverse polarity protection.

# Section 5 Maintenance and Troubleshooting

---

|                               |          |
|-------------------------------|----------|
| Overview .....                | page 5-1 |
| Safety Messages .....         | page 5-2 |
| Test Terminals .....          | page 5-2 |
| Board Checkout .....          | page 5-2 |
| Sensing Module Checkout ..... | page 5-3 |
| Disassembly Procedure .....   | page 5-4 |
| Reassembly Procedure .....    | page 5-6 |
| Post Assembly Tests .....     | page 5-9 |

---

**⚠ WARNING**

Use only the procedures and new parts specifically referenced in this manual to ensure specification performance and certification compliance. Unauthorized procedures or parts can render the instrument dangerous to life, limb, or property.

## OVERVIEW

This section outlines a technique for checking out the components, a method for disassembly and reassembly, and a troubleshooting guide.

### NOTE

Maintenance of traceability of any replacement parts is the responsibility of the user (see “Important Notice” on page 6-11 and **Important Notice** at the beginning of this manual preceding the Table of Contents).

The Rosemount 1154 has no moving parts and requires a minimum of scheduled maintenance. Calibration procedures for range adjustment are outlined in Section 3: Calibration. A calibration check should be conducted after inadvertent exposure to overpressure, unless your plant considers this factor separately in the plant error analysis.

Test terminals are available for in-process checks. For further checks, the transmitter can be divided into three active physical components: the sensing module, the amplifier board, and the calibration board.

An exploded view of the transmitter is provided in Figure 5-2 on page 5-5. In the following procedures, numbers in parentheses refer to item numbers in the exploded view.



## SAFETY MESSAGES

Instructions and procedures in this section may require special precautions to ensure the safety of the people performing the operations. Information that raises potential safety issues is indicated by a warning message. The following warning messages appear in this section.

### ⚠ WARNING

Use only the procedures and new parts specifically referenced in this manual to ensure specification performance and certification compliance. Unauthorized procedures or parts can render the instrument dangerous to life, limb, or property.

### ⚠ WARNING

Process O-rings may retain some process fluid after disassembly of process flanges. If this fluid is determined to be contaminated, take appropriate safety measures.

## TEST TERMINALS

The test terminals are connected across a diode through which the loop signal current passes. The indicating meter or test equipment shunts the diode when connected to the test terminals. As long as the voltage across the terminals is kept below the diode threshold voltage, no current passes through the diode. To ensure that there is no current leaking through the diode while making a test reading or when connecting an indicating meter, the resistance of the test connection or meter should not exceed 10 Ω.

## BOARD CHECKOUT

### NOTE

Numbers in parentheses refer to item numbers in Figure 5-2 on page 5-5.

### NOTE

The Rosemount 1154 Pressure Transmitter contains electronic circuit boards which may be static sensitive.

You can easily check the printed circuit boards (5 and 6) for a malfunction by substituting spare boards into the circuit. If this procedure turns up a malfunctioning board, return the defective board to Rosemount Nuclear Instruments, Inc. for replacement. Because of parts traceability, qualification becomes the responsibility of the customer in the event of unauthorized board repairs.

Figure 5-1. Header Board Connections.

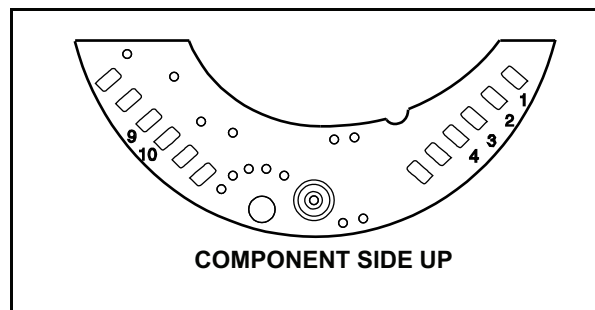

---

**SENSING MODULE  
CHECKOUT**

---

**NOTE**

Numbers in parentheses refer to item numbers in Figure 5-2 on page 5-5.

---

The sensing module (12) is not field-repairable and must be replaced if defective. If no defect such as a punctured isolating diaphragm or loss of fill fluid is observed, check the sensing module in the following manner:

1. Disengage the header assembly board (4) as described in step four of the electrical housing disassembly procedure on page 5-6. You need not remove the sensing module from the electrical housing for checkout.
2. Jump connections 1 and 2 on the header assembly board (see Figure 5-1 on page 5-2).
3. Using a low-voltage ohmmeter, check the resistance between the jumper wire and the sensing module housing. This resistance should be greater than 10 M $\Omega$ . Remove the jumper wire.
4. Jump connections 3 and 4 on the header assembly board and repeat step 3 (see Figure 5-1 on page 5-2).

---

**NOTE**

The above procedure does not completely test the sensing module. If circuit board replacement does not correct the abnormal condition and no other problems are obvious, replace the sensing module.

---

## DISASSEMBLY PROCEDURE

### Process Flange Removal

---

**NOTE**

Numbers in parentheses refer to item numbers in Figure 5-2 on page 5-5.

---

---

**NOTE**

The Rosemount 1154 Pressure Transmitter contains electronic circuit boards which may be static sensitive.

---

**⚠ WARNING**

Process O-rings may retain some process fluid after disassembly of process flanges. If this fluid is determined to be contaminated, take appropriate safety measures.

---

---

**NOTE**

Read the Process Flange Reassembly Procedure on page 5-8 before attempting disassembly. Special testing and traceability are required.

---

1. Remove the transmitter from service before disassembling flanges.
  2. Detach process flanges (13, 15) by removing the four large bolts (14). **Take care not to scratch or puncture the isolating diaphragms.** Identify high and low ("H" and "L") flanges for reassembly.
- 

---

**NOTE**

Carefully remove the O-rings (11) from the cell if they do not come off when the flange is removed. Do not pry the O-ring from its seat, as you may damage the isolating diaphragm.

---

3. Clean isolating diaphragms with a soft rag and a mild cleaning solution. Do not use any chlorine or acid solutions to clean the diaphragms. Rinse diaphragms with distilled water.

Figure 5-2. Rosemount 1154, Exploded View.

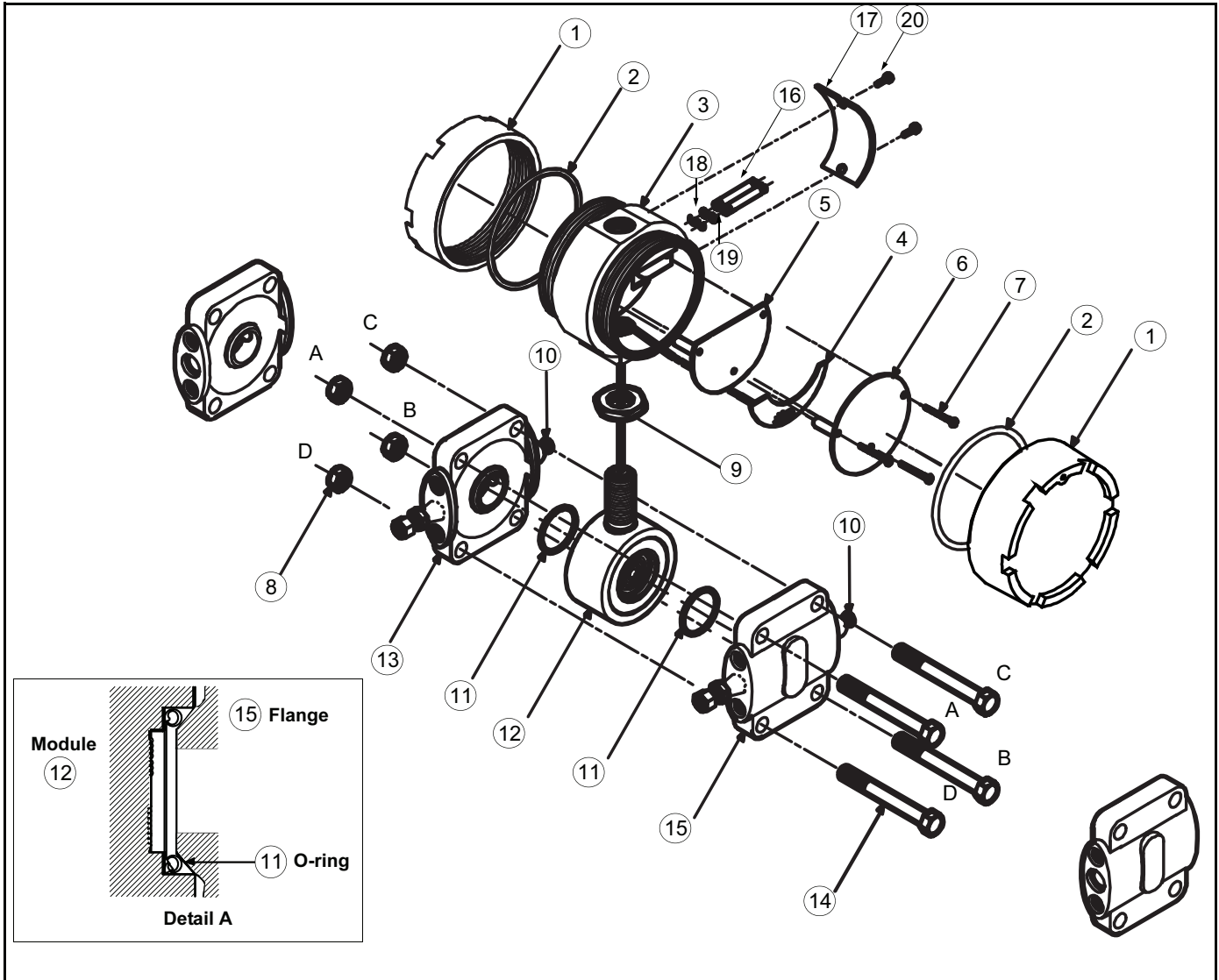

Table 5-1. Rosemount 1154 Parts List.

| Part | Description                  | Part | Description                     |
|------|------------------------------|------|---------------------------------|
| 1    | Electronics Cover            | 11   | Metal O-Ring for Process Flange |
| 2    | O-Ring for Electronics Cover | 12   | Sensor Module                   |
| 3    | Electronics Housing          | 13   | Process Flange                  |
| 4    | Header Assembly Board        | 14   | Process Flange Bolts            |
| 5    | Calibration Board            | 15   | Process Flange                  |
| 6    | Amplifier Board              | 16   | Zero and Span Adjustment Screws |
| 7    | Holding Screws               | 17   | Nameplate                       |
| 8    | Process Flange Nuts          | 18   | Snap Rings                      |
| 9    | Sensor Module Lock Nut       | 19   | O-Ring for Adjustment Screw     |
| 10   | Valve Stem                   | 20   | Nameplate Screws                |

# Rosemount 1154

---

## Electrical Housing Disassembly

1. The signal terminals and test terminals are accessible by unscrewing the cover (1) on the terminal side. This compartment is identified as “terminal side” on the nameplate. The terminals are permanently attached to the housing and must not be removed.
2. Circuit boards are located in a separate compartment identified as “Circuit Side” on the nameplate. Remove power from the transmitter before removing the circuit side cover. Unscrew the cover (1) on the circuit side to access the circuit boards. A special cover wrench (RMT P/N 01153-0382-0001) is available from Rosemount to remove and replace the housing covers.
3. Unplug the amplifier board (6) after removing 3 holding screws (7).
4. The header assembly board (4) is permanently attached to the sensor module (12) and contains the temperature-compensating resistors. Carefully pull this board off the bayonet pins and rotate the board 180 degrees about the axis formed by the connecting leads. This allows access to the calibration board (5).
5. Disconnect the calibration board (5) by aligning the zero and span adjust screws so that their slots are perpendicular to the board. Remove the board by inserting a 6–32 screw in the rivnut on the board and carefully pulling the board off the bayonet pins.
6. If replacement of the zero and span adjustment screws (16) is necessary, remove the nameplate (17) and detach the snap rings (18) inside the housing.

## Removing Sensor Module from Electrical Housing

1. Remove flanges per Process Flange Removal Section on page 5-4.
2. Remove amplifier board and calibration board as described in the Electrical Housing Disassembly Section above.
3. Loosen the lock nut (9).
4. Unscrew the sensor module (12) from the electronics housing, simultaneously turning the header board and leads to prevent them from being twisted or damaged. The threaded connection has a sealing compound on it and must be broken loose. **Be careful not to damage the isolating diaphragms when unscrewing the sensor module.** Then carefully pull the header assembly board (4) through the hole.
5. The sensor module (12) is a welded assembly and cannot be further disassembled.

## REASSEMBLY PROCEDURE

---

### NOTE

Numbers in parentheses refer to item numbers in Figure 5-2 on page 5-5.

---

### NOTE

The Rosemount 1154 Pressure Transmitter contains electronic circuit boards which may be static sensitive.

---



## Preliminary

1. Replace the cover O-rings (2) whenever you remove a cover. Clean the sealing areas with alcohol, if necessary, and lightly grease the O-ring with Dow Corning 55 Silicone O-ring Grease (Rosemount P/N 01153-0248-0001 or P/N 01153-0053-0001). Spray the inside threads of the electronics covers with cover lubricant (Rosemount P/N 01153-0333-0001 or equivalent) if necessary; if covers are already sufficiently lubricated, do not spray.
2. Verify that the circuit boards are clean.
3. Verify that the bayonet pins on the connection board are clean.
4. If you remove the sensor module, clean the thread sealant from the sensor module threads, lock nut, and electronics housing threads with a wire brush.

## Connecting the Electrical Housing to the Sensor Module

1. Run the lock nut down to the base of the sensor module threads.
2. Apply a heavy, continuous bead (about  $\frac{3}{8}$ -in. wide) of Loctite<sup>®</sup> 580-PST sealant (RMT P/N 01153-0329-0001) around the top sensor module threads.
3. Insert the header assembly board (4) through the hole in the bottom of the electronics housing.
4. Screw the sensor module (12) into the electrical housing (3) making sure that five full threads are engaged. Be careful not to damage or twist the sensor leads. Turn the header board to avoid twisting wires.
5. Align the sensor module with the high and low pressure sides oriented per Figure 2-5 on page 2-7. Alternately, tighten the module one-half turn further to reverse the orientation of the module about the electronics housing.
6. Tighten the lock nut (9) to 35 ft-lb (48 N-m) torque.
7. Wipe off excess sealant.
8. Place the assembled unit in an oven at  $200 \pm 5$  °F ( $93 \pm 3$  °C) for 12 hours to cure the sealant.

## Electrical Housing Reassembly

1. Replace the zero and span adjustment screw O-rings (19) whenever you remove the zero and span adjustment screws (16). Lightly grease the O-rings with Dow Corning 55 Silicone O-ring Grease (Rosemount P/N 01153-0248-0001 or P/N 01153-0053-0001). Reinstall the adjustment screws and secure with snap rings (18).
2. Align the zero and span adjustment screws with the potentiometer stems on the calibration board (5) and push the calibration board onto the bayonet pins.
3. Slide the header assembly board (4) onto the bayonet pins with the component side toward the pins. Slide any excess wire behind the calibration board, **taking care to avoid kinks**.
4. Push the amplifier board (6) onto the bayonet pins and secure with holding screws (7). Use nominal torque of 10 in-lb (1.1 N-m).
5. Carefully replace the cover and tighten to 16.5 ft-lb (22.4 N-m) ("Preliminary" on page 5-7).
6. Replace the nameplate (17), and secure with two nameplate screws (20).

# Rosemount 1154

---

## Process Flange Reassembly

1. Replace the metal O-rings (11) with new O-rings if the flanges were removed.
2. Carefully place an O-ring (11) in the isolator well of the high side ("H") of the sensing module. Place the O-ring so the edge of the rolled ring faces the module (see Detail A of Figure 5-2 on page 5-5).
3. Carefully place the flange (13 or 15) as shown in Figure 5-2 on page 5-5. Take care not to disturb the O-rings or damage the diaphragms.
4. On differential units, repeat steps 2 and 3 for the low side ("L") of the module. If a gage unit has two O-rings (one on each side), repeat steps 2 and 3 for the low side. If the gage unit has only one O-ring, reassemble with one O-ring on the high side.
5. Keeping the flanges parallel to each other and to the module faces, insert the four bolts (14) (and four washers on Range Code 9) and finger-tighten the nuts (8).

Each spare parts kit contains the correct number of nuts, bolts, and washers for the specific transmitter range code it is designated for. Due to consolidation of parts kits, the bolt length and quantity of washers required may differ from existing transmitter assemblies and/or parts kits. Verify by part number that the appropriate spare parts kit is used for the transmitter range code being re-assembled. Contact Rosemount Nuclear Instruments, Inc. if there are questions.

6. Evenly seat the flanges on the sensor module housing, using a hand torque wrench as specified in steps 7 through 11. See Figure 5-2 on page 5-5 to identify the bolts.
7. Alternately tighten bolts A and B to 10 ft-lb (13.6 N-m) torque.
8. Alternately tighten bolts C and D to 10 ft-lb (13.6 N-m) torque.
9. Check the torque on bolts A and B.
10. Check the torque on bolts C and D.
11. Repeat steps (7)-(10) at 15 ft-lb (20 N-m) torque, at 20 ft-lb (27 N-m) torque, at 25 ft-lb (34 N-m) torque, at 30 ft-lb (41 N-m) torque, and at 35 ft-lb (48 N-m) torque until all bolts are torqued to  $35 \pm 1$  ft-lb ( $48 \pm 1$  N-m).
12. Expose all ranges of gage transmitters to two temperature cycles over the expected temperature operating range before calibrating. Expose differential and high-line differential Range Code 4's to two temperature cycles over the expected temperature operating range before calibrating.

**POST ASSEMBLY TESTS**

1. Conduct hydrostatic testing to 150% of maximum working pressure or 2,000 psi, whichever is greater.
2. Calibrate the transmitter per the calibration section of this manual.
3. Conduct nuclear cleaning to 1 ppm chloride content of transmitter "wetted parts."

Table 5-2. Torque References.

| ITEM(S) TO BE TORQUED           | TORQUE VALUE                                       | TOLERANCE            |
|---------------------------------|--|----------------------|
| Bracket to Mounting Panel Bolts | 19 ft-lb (26 N-m)                                  | ±1 ft-lb (1 N-m)     |
| Transmitter to Bracket Bolts    | 21 ft-lb (29 N-m)                                  | ±1 ft-lb (1 N-m)     |
| Swagelok Process Fittings       | See Installation Instructions                      | —                    |
| Drain/Vent Valves               | 7.5 ft-lb (10 N-m)                                 | ±0.5 ft-lb (0.7 N-m) |
| Covers                          | 16.5 ft-lb (22.4 N-m)                              | ±1 ft-lb (1 N-m)     |
| Module Neck Lock Nut            | 35 ft-lb (48 N-m)                                  | ±1 ft-lb (1 N-m)     |
| Conduit Fitting                 | 4 to 7 turns or a minimum of 12.5 ft-lb (16.9 N-m) | ±1 ft-lb (1 N-m)     |
| Flange Bolts                    | See Process Flange Reassembly                      | —                    |
| Terminal Block Screws           | 5 in-lb (0.6 N-m) or hand tight                    | ±1 in-lb (0.1 N-m)   |
| Amplifier Board Screws          | Nominal 10 in-lb (1.1 N-m)                         | —                    |

Table 5-3. Troubleshooting.

| Symptom     | Potential Source                | Corrective Action  |
|-------------|---------------------------------|--|
| High Output | Primary Element                 | Check for restrictions at primary element, improper installation or poor condition. Note any changes in process fluid properties that may affect output.   |
|             | Impulse Piping                  | Check for leaks or blockage.<br>Ensure blocking locking valves are fully open.<br>Check for entrapped gas in liquid lines, or liquid in dry lines.<br>Ensure that density of fluid in impulse line is unchanged.<br>Check for sediment in transmitter process flanges.   |
|             | Transmitter Electronics         | Make sure that post connectors and the sensor connections are clean. If the electronics are still suspect, substitute new electronics.   |
|             | Transmitter Electronics Failure | Determine faulty circuit board by trying spare boards. Replace faulty circuit board.   |
|             | Sensing Module                  | See Sensing Module Checkout section. The sensing element is not field repairable and must be replaced if found to be defective. See "Disassembly Procedure" for instructions on disassembly. Check for obvious defects, such as a punctured isolating diaphragm or fill fluid loss, and contact Rosemount Nuclear Instruments, Inc. at (952) 949-5210. |
|             | Power Supply                    | Check the power supply output voltage at the transmitter.  |

**Continued on Next Page**

| Symptom                 | Potential Source                       | Corrective Action   |
|-------------------------|--|---|
| Low Output or No Output | Primary Element                        | Check for restrictions at primary element, improper installation or poor condition. Note any changes in process fluid properties that may affect output.  |
|                         | Loop Wiring                            | <div style="text-align: center; background-color: black; color: white; padding: 5px;"><b>⚠ CAUTION</b></div> <div style="border: 1px solid black; padding: 5px; margin-top: 5px;">Do not use over 100 volts to check the loop, or damage to the transmitter electronics may result.</div> <p>Check for adequate voltage to the transmitter.<br/>Check the milliamp rating of the power supply against the total current being drawn for all transmitters being powered.<br/>Check for shorts and multiple grounds.<br/>Check for proper polarity at the signal terminal.<br/>Check loop impedance.<br/>Check wire insulation to detect possible shorts to ground.</p> |
|                         | Impulse Piping                         | Ensure that the pressure connection is correct.<br>Check for leaks or blockage.<br>Check for entrapped gas in liquid lines.<br>Check for sediment in the transmitter process flange.<br>Ensure that blocking valves are fully open and that bypass valves are tightly closed.<br>Ensure that density of the fluid in the impulse piping is unchanged.   |
|                         | Transmitter Electronics Connections    | Ensure that calibration adjustments are in allowable range.<br>Check for shorts in sensor leads.<br>Make sure post connectors are clean, and check the sensor connections.<br>If the electronics are still suspect, substitute new electronics.   |
|                         | Test Diode Failure                     | Replace electronics housing.  |
|                         | Transmitter Electronics Failure        | Determine faulty circuit board by trying spare boards. Replace faulty circuit board.  |
|                         | Sensing Module                         | NOTE: See Sensing Module Checkout section. The sensing element is not field repairable and must be replaced if found to be defective. See "Disassembly Procedure" for instructions on disassembly. Check for obvious defects, such as a punctured isolating diaphragm or fill fluid loss, and contact Rosemount Nuclear Instruments, Inc. at (952) 949-5210.  |
|                         | Power Supply                           | Check the power supply output voltage at the transmitter.   |
| Erratic Output          | Loop Wiring                            | <div style="text-align: center; background-color: black; color: white; padding: 5px;"><b>⚠ CAUTION</b></div> <div style="border: 1px solid black; padding: 5px; margin-top: 5px;">Do not use over 100 volts to check the loop, or damage to the transmitter electronics may result.</div> <p>Check for inadequate voltage to the transmitter.<br/>Check for intermittent shorts, open circuits, or multiple grounds.</p>  |
|                         | Impulse Piping and Process Connections | Check for entrapped gas in liquid lines, or liquid in dry lines.  |
|                         | Transmitter Electronics                | Check for intermittent shorts or open circuits.<br>Make sure that bayonet and sensor connectors are clean and properly connected.   |
|                         | Transmitter Electronics Failure        | Determine faulty circuit boards by trying spare boards. Replace faulty circuit board.   |
|                         | Power Supply                           | Check power supply output voltage.  |

# Section 6 Specifications and Reference Data

---

|                                  |           |
|----------------------------------|-----------|
| Nuclear Specifications .....     | page 6-1  |
| Performance Specifications ..... | page 6-2  |
| Functional Specifications .....  | page 6-4  |
| Physical Specifications .....    | page 6-6  |
| Ordering Information .....       | page 6-8  |
| Spare Parts Shelf Life .....     | page 6-11 |
| Important Notice .....           | page 6-11 |

---

## NUCLEAR SPECIFICATIONS

Qualified per IEEE Std 323-1974 and IEEE Std 344-1975, as stated in Rosemount Report D8400102.

### Radiation

Accuracy within  $\pm(1.5\%$  of upper range limit + 1.0% of span) during and after exposure to 55 megarads TID gamma radiation at the centerline at the following dose rate: 2 megarads/hr for 2 hr, 1.5 megarad/hr for 4 hr, 1 megarad/hr up to 55 megarads TID and an additional 55 megarads TID at a rate of 1 megarad/hr during post-accident operation

Range Code 0:  $\pm(2.25\%$  of upper range limit + 1.0% of span)

### Seismic

Accuracy within  $\pm 0.5\%$  of upper range limit after a seismic disturbance defined by a required response spectrum with a ZPA of 7 g

Range Code 0:  $\pm 0.75\%$  of upper range limit

### Steam Pressure/Temperature

Accuracy within  $\pm(2.5\%$  upper range limit + 0.5% of span) during and after sequential exposure to steam at the following temperatures and pressures, concurrent with chemical spray for the first 24 hr:

- 420 °F (215.6 °C), 50 psig for 3 minutes
- 350 °F (176.6 °C), 110 psig for 7 minutes
- 320 °F (160.0 °C), 75 psig for 8 hours
- 265 °F (129.4 °C), 24 psig for 56 hours

Range Code 0:  $\pm(3.75\%$  of upper range limit + 0.5% of span)

### Chemical Spray

Composition is 0.28 molar boric acid, 0.064 molar sodium thiosulfate, and sodium hydroxide to make an initial pH of 11.0 and a subsequent pH ranging from 8.5 to 11.0. Chemical spray is sprayed at a rate of 0.25 gal/min/ft<sup>2</sup>.



**Post DBE Operation**

Accuracy at reference conditions shall be within  $\pm 2.5\%$  of upper range limit ( $\pm 3.75\%$  for Range Code 0) for one year following DBE.

**Quality Assurance Program**

In accordance with NQA-1, 10CFR50 Appendix B, and ISO 9001:2000

**Nuclear Cleaning**

To 1 ppm maximum chloride content

**Hydrostatic Testing**

To 150% of maximum working pressure or 2,000 psi (13.8 MPA), whichever is greater

**Traceability**

In accordance with NQA-1, 10CFR50 Appendix B; chemical and physical material certification of pressure-retaining parts

**Qualified Life**

The transmitter qualified life is dependent on continuous ambient temperature at the installation site (see Figure 6-1). Replacement of amplifier and calibration circuit boards at the end of their qualified life permits extension of the transmitter qualified life to the module qualified life. See Rosemount Report D8400102 for details.

Figure 6-1. Qualified Life vs. Ambient Temperature.

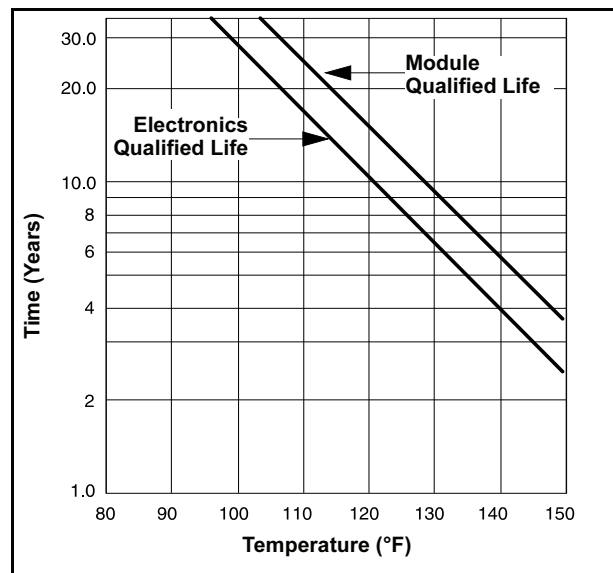

**PERFORMANCE SPECIFICATIONS**

Based on zero-based ranges under reference conditions.

**Accuracy**

$\pm 0.25\%$  of calibrated span; includes combined effects of linearity, hysteresis, and repeatability

**Dead Band**

None

**Drift**

±0.2% of upper range limit for 30 months

Range Code 0: ±(0.3% of upper range limit)

**Temperature Effect**

**Range Codes 4–9:**

±(0.75% upper range limit +0.5% span) per 100 °F (55.6 °C) ambient temperature change

**Range Code 0:**

±(1.13% upper range limit +0.5% span) per 100 °F (55.6 °C) ambient temperature change

**Overpressure Effect**

**Rosemount 1154DP:**

Maximum zero shift after 2,000 psi (13.8 MPa) overpressure:

| Range Code | Overpressure Effect         |
|------------|-----------------------------|
| 4          | ±0.25% of upper range limit |
| 5          | ±1.0% of upper range limit  |
| 6, 7       | ±3.0% of upper range limit  |
| 8          | ±6.0% of upper range limit  |

**Rosemount 1154HP:**

Maximum zero shift after 3,000 psi (20.68 MPa) overpressure:

| Range Code | Overpressure Effect        |
|------------|----------------------------|
| 4          | ±1.0% of upper range limit |
| 5          | ±2.0% of upper range limit |
| 6, 7       | ±5.0% of upper range limit |

**Rosemount 1154GP:**

Maximum zero shift after 2,000 psi (13.8 MPa) overpressure:

| Range Code | Overpressure Effect         |
|------------|-----------------------------|
| 4          | ±0.25% of upper range limit |
| 5–8        | ±1.0% of upper range limit  |

After 4,500 psi (31.0 MPa) overpressure:

| Range Code | Overpressure Effect        |
|------------|----------------------------|
| 9          | ±0.5% of upper range limit |

After 6,000 psi (41.37 MPa) overpressure:

| Range Code | Overpressure Effect         |
|------------|-----------------------------|
| 0          | ±0.25% of upper range limit |

### Static Pressure Zero Effect

**Rosemount 1154DP:**  
Per 1,000 psi (6.89 MPa):

| Range Code | Static Pressure Zero Effect |
|------------|-----------------------------|
| 4, 5       | ±0.2% of upper range limit  |
| 6-8        | ±0.5% of upper range limit  |

**Rosemount 1154HP:**  
Per 1,000 psi (6.89 MPa):

| Range Code | Static Pressure Zero Effect |
|------------|-----------------------------|
| All Ranges | ±0.66% of upper range limit |

### Static Pressure Span Effect

Effect is systematic and can be calibrated out for a particular pressure before installation. Correction uncertainty is ±0.5% of input reading/1,000 psi (6.89 MPa).

### Power Supply Effect

Less than 0.005% of output span/volt

### Load Effect

No load effect other than the change in voltage supplied to the transmitter

### Mounting Position Effect

No span effect; zero shift of up to 1.5 inH<sub>2</sub>O (372 Pa) which can be calibrated out

### Response Time

Fixed time constant (63%) at 100 °F (37.8 °C) as follows:

| Range Code | Response Time       |
|------------|---------------------|
| 4          | 0.5 seconds or less |
| all others | 0.2 seconds or less |

Adjustable damping is available through a special N option.

## FUNCTIONAL SPECIFICATIONS

### Service

Liquid, gas, or vapor

### Output

4–20 mA dc

### Power Supply

Design limits are as shown in Figure 2-3 on page 2-5. See qualification report D8400102 for additional detail.



**Span and Zero**

Continuously adjustable externally

**Zero Elevation and Suppression**

Maximum zero elevation: 600% of calibrated span  
 (400% of calibrated span for Range Code 0)

Maximum zero suppression: 500% of calibrated span (300% of calibrated span for Range Code 0)

Zero elevation and suppression must be such that neither the calibrated span nor the upper or lower range value exceeds 100% of the upper range limit.

**Temperature Limits**

Normal operating limits: 40 to 200 °F (4.4 to 93.3 °C)

Qualified storage limits: -40 to 120 °F (-40.0 to 48.9 °C)

**Humidity Limits**

0–100% relative humidity (NEMA 4X)

**Volumetric Displacement**

Less than 0.01 in<sup>3</sup> (0.16 cm<sup>3</sup>)

**Turn-on Time**

2 seconds maximum. No warm-up required

**Pressure Ranges**

**Rosemount 1154DP and 1154HP:**

| Range Code | Pressure Ranges  |
|------------|--|
| 4          | 0–25 to 0–150 inH <sub>2</sub> O (0–6.22 to 0–37.3 kPa)        |
| 5          | 0–125 to 0–750 inH <sub>2</sub> O (0–31.08 to 0–186.4 kPa)     |
| 6          | 0–17 to 0–100 psi (0–0.12 to 0–0.69 MPa)                       |
| 7          | 0–50 to 0–300 psi (0–0.34 to 0–2.07 MPa)                       |
| 8          | 0–170 to 0–1,000 psi (0–1.17 to 0–6.89 MPa)<br>(DP units only) |

**Rosemount 1154GP:**

| Range Code | Pressure Ranges                                |
|------------|--|
| 4–8        | as listed for Rosemount 1154DP                 |
| 9          | 0–500 to 0–3,000 psi (0–3.45 to 0–20.68 MPa)   |
| 0          | 0–1,000 to 0–4,000 psi (0–6.89 to 0–27.56 MPa) |

**Maximum Working Pressure**

**Rosemount 1154DP and 1154HP:**

Static pressure limit

**Rosemount 1154GP:**

Upper range limit

## Static Pressure and Overpressure Limits

### Rosemount 1154DP:

0.5 psia to 2,000 psig (3.4 kPa abs to 13.8 MPa) maximum rated static pressure for operation within specifications; overpressure limit is 2,000 psig (13.8 MPa) on either side without damage to the transmitter.

### Rosemount 1154HP:

0.5 psia to 3,000 psig (3.4 kPa abs to 20.7 MPa) maximum rated static pressure for operation within specifications; overpressure limit is 3,000 psig (20.7 MPa) on either side without damage to the transmitter.

## Overpressure Limits

### Rosemount 1154GP:

Operates within specifications from 0.5 psia (3.4 kPa abs) to upper range limit. Overpressure limits without damage to the transmitter:

| Range Code | Overpressure Limit     |
|------------|------------------------|
| 4-8        | 2,000 psig (13.8 MPa)  |
| 9          | 4,500 psig (31.0 MPa)  |
| 0          | 6,000 psig (41.34 MPa) |

## PHYSICAL SPECIFICATIONS

### Materials of Construction

#### Isolating Diaphragms:

316L SST

#### Drain/Vent Valves:

316 SST

#### Process Flanges:

CF-8M (cast version of 316 SST)

#### Process O-rings:

316L SST

#### Electronics Housing O-rings:

Ethylene propylene

#### Fill Fluid:

Silicone oil

#### Flange Bolts and Nuts:

Plated alloy steel, as specified in ASTM A540

#### Electronics Housing:

316 SST

#### Mounting Bracket:

316L SST

#### Mounting Bolts (Bracket to transmitter):

SAE J429 carbon steel, Grade 2 or Grade 5

**Electrical Connections**

1/2–14 NPT conduit with screw terminals

**Process Connections**

3/8 in. Swagelok compression fitting, 316 SST  
(1/4–18 NPT optional)

**Weight**

24 lb (10.9 kg) including mounting bracket

## ORDERING INFORMATION

Table 6-1. Transmitter Design Specifications.

| Model                                      | Description  |   |   |
|--|--|---|---|
| 1154                                       | Alphaline Pressure Transmitters for Nuclear Applications, IEEE Std 323-1974 and IEEE Std 344-1975        |   |   |
| Code                                       | Pressure Measurement   |   |   |
| DP   | Differential Pressure, 2,000 psig (13.8 MPa) Static Pressure Rating                                      |   |   |
| HP   | Differential Pressure, 3,000 psig (20.68 MPa) Static Pressure Rating                                     |   |   |
| GP   | Gage Pressure  |   |   |
| PRESSURE RANGES at 68 °F                   |  |   |   |
| Code                                       | Rosemount 1154DP<br>(Differential)   | Rosemount 1154HP<br>(Differential)                            | Rosemount 1154GP<br>(Gage)                                    |
| 4  | 0–25 to 0–150 inH <sub>2</sub> O<br>(0–6.22 to 0–37.3 kPa)   | 0–25 to 0–150 inH <sub>2</sub> O<br>(0–6.22 to 0–37.3 kPa)    | 0–25 to 0–150 inH <sub>2</sub> O<br>(0–6.22 to 0–37.3 kPa)    |
| 5  | 0–125 to 0–750 inH <sub>2</sub> O<br>(0–31.08 to 0–186.4 kPa)  | 0–125 to 0–750 inH <sub>2</sub> O<br>(0–31.08 to 0–186.4 kPa) | 0–125 to 0–750 inH <sub>2</sub> O<br>(0–31.08 to 0–186.4 kPa) |
| 6  | 0–17 to 0–100 psi<br>(0–0.12 to 0–0.69 MPa)  | 0–17 to 0–100 psi<br>(0–0.12 to 0–0.69 MPa)                   | 0–17 to 0–100 psi<br>(0–0.12 to 0–0.69 MPa)                   |
| 7  | 0–50 to 0–300 psi<br>(0–0.34 to 0–2.07 MPa)  | 0–50 to 0–300 psi<br>(0–0.34 to 0–2.07 MPa)                   | 0–50 to 0–300 psi<br>(0–0.34 to 0–2.07 MPa)                   |
| 8  | 0–170 to 0–1,000 psi<br>(0–1.17 to 0–6.89 MPa)   | —   | 0–170 to 0–1,000 psi<br>(0–1.17 to 0–6.89 MPa)                |
| 9  | —  | —   | 0–500 to 0–3,000 psi<br>(0–3.45 to 0–20.68 MPa)               |
| 0  | —  | —   | 0–1,000 to 0–4,000 psi<br>(0–6.89 to 0–27.56 MPa)             |
| Code                                       | Output   |   |   |
| R <sup>(1)</sup>                           | Standard 4–20 mA   |   |   |
| Code                                       | Flange Option  |   |   |
| A  | Welded 3/8 in. <i>Swagelok</i> Compression Fitting Process Connection and Welded Drain/Vent Valve        |   |   |
| B <sup>(2)</sup>                           | 1/4–18 NPT Process Connection and Welded Drain/Vent Valve  |   |   |
| C <sup>(2)</sup>                           | 1/4–18 NPT Process Connection and Drain Hole (Drain/Vent Valve not supplied)                             |   |   |
| D  | One Flange Code Option A and One Remote Seal   |   |   |
| E <sup>(2)</sup>                           | One Flange Code Option B and One Remote Seal   |   |   |
| F <sup>(2)</sup>                           | One Flange Code Option C and One Remote Seal   |   |   |
| G  | Two Remote Seals   |   |   |
| H  | Welded 3/8 in. <i>Swagelok</i> Compression Fittings on Both Process Connection and Drain/Vent Connection |   |   |
| J <sup>(2)</sup>                           | Welded 3/8 in. <i>Swagelok</i> Compression Fitting Process Connection and 1/4–18 NPT Drain Hole          |   |   |
| L  | One Flange Code Option H and One Remote Seal   |   |   |
| M <sup>(2)</sup>                           | One Flange Code Option J and One Remote Seal   |   |   |
| <b>Typical Model Number: 1154 DP 4 R A</b> |  |   |   |

(1) The Rosemount 1154 with Output Code R Electronics is also available with adjustable damping. This option is specified by appending "N0037" to the end of the complete model number, for example, 1154DP4RAN0037.

(2) Note: Customer assumes responsibility for qualifying connection interfaces on these options. Contact Rosemount Nuclear Instruments, Inc. for details.

Table 6-2. Rosemount 1154DP, 1154HP, and 1154GP Spare Parts.

| Spare Parts Category <sup>(1)</sup>                      |    |                    |   |   | Rosemount<br>1154DP | Rosemount<br>1154HP | Rosemount<br>1154GP |
|--|----|--------------------|---|---|---------------------|---------------------|---------------------|
| Traceable Part   |    |                    |   |   |                     |                     |                     |
| Quantity Required  |    |                    |   |   |                     |                     |                     |
| Item Number (see Figure 5-2 on page 5-5)                 |    |                    |   |   |                     |                     |                     |
| Part Description   |    |                    |   |   | Order No.           | Order No.           | Order No.           |
| Amplifier Cir. Board, Output Code R                      | 6  | 1                  |   | A | 01154-0001-0005     | 01154-0001-0005     | 01154-0001-0005     |
| Calib. Cir. Board, Output Code R                         | 5  | 1                  |   | A | 01154-0002-0001     | 01154-0002-0001     | 01154-0002-0001     |
| Amplifier Cir. Board with Damping,<br>Output Code R      | 6  | 1                  |   | A | 01154-0021-0004     | 01154-0021-0004     | 01154-0021-0004     |
| Calib. Cir. Board with Damping,<br>Output Code R         | 5  | 1                  |   | A | 01154-0023-0002     | 01154-0023-0002     | 01154-0023-0002     |
| Sensor Module, 316 SST                                   | 12 | 1                  |   |   |                     |                     |                     |
| 0–25/150 inH <sub>2</sub> O                              |    |                    | X | B | 01154-0300-0242     | 01154-0300-0342     | 01154-0300-0142     |
| 0–125/750 inH <sub>2</sub> O                             |    |                    | X | B | 01154-0300-0252     | 01154-0300-0352     | 01154-0300-0152     |
| 0–17/100 psi   |    |                    | X | B | 01154-0300-0262     | 01154-0300-0362     | 01154-0300-0162     |
| 0–50/300 psi   |    |                    | X | B | 01154-0300-0272     | 01154-0300-0372     | 01154-0300-0172     |
| 0–170/1,000 psi  |    |                    | X | B | 01154-0300-0282     | —                   | 01154-0300-0182     |
| 0–500/3,000 psi  |    |                    |   | B | —                   | —                   | 01154-0300-0192     |
| 0–1,000/4,000 psi  |    |                    |   | B | —                   | —                   | 01154-0300-0102     |
| Electronics Housing, Austenitic SST                      | 3  | 1                  |   |   | 01153-0211-0001     | 01153-0211-0001     | 01153-0211-0001     |
| Electronics Cover, Austenitic SST                        | 1  | 2                  |   |   | 01153-0204-0001     | 01153-0204-0001     | 01153-0204-0001     |
| Cover Wrench   |    |                    |   |   | 01153-0382-0001     | 01153-0382-0001     | 01153-0382-0001     |
| Hollow Terminal Block Screw Kit                          |    |                    |   |   | 01153-0041-0001     | 01153-0041-0001     | 01153-0041-0001     |
| Solid Terminal Block Screw Kit<br>(Kit Contains 20 each) |    |                    |   |   | 01153-0330-0001     | 01153-0330-0001     | 01153-0330-0001     |
| Process Flange, Welded <i>Swagelok</i>                   | 13 | See<br>note<br>(2) | X |   | 01153-0175-0001     | 01153-0175-0001     | 01153-0175-0001     |
| Process Flange, ¼–18 NPT                                 |    |                    | X |   | 01153-0175-0002     | 01153-0175-0002     | 01153-0175-0002     |
| Process Flange, ¼–18 NPT/¼–18 NPT                        |    |                    | X |   | 01153-0291-0001     | 01153-0291-0001     | 01153-0291-0001     |
| Vented Blank Flange                                      |    |                    |   |   | —                   | —                   | 01153-0234-0001     |
| Valve Stem, 316 SST                                      | 10 | 2                  | X | A | 01153-0277-0001     | 01153-0277-0001     | 01153-0277-0001     |
| Valve Stem and Seat Kit, 316 SST                         |    |                    |   |   | 01153-0038-0001     | 01153-0038-0001     | 01153-0038-0001     |
| Axial Drain/Vent Valve Kit                               |    |                    |   |   | 01153-0350-0002     | 01153-0350-0002     | 01153-0350-0002     |
| Quick Disconnect Axial Drain/Vent Valve Kit              |    |                    |   |   | 01153-0373-0001     | 01153-0373-0001     | 01153-0373-0001     |
| Adjustment Screw Kit                                     |    | 1                  |   |   | 01153-0294-0001     | 01153-0294-0001     | 01153-0294-0001     |
| Adjustment Screw <sup>(2)</sup>                          | 16 |                    |   |   |                     |                     |                     |
| Retaining Ring <sup>(2)</sup>                            | 18 |                    |   |   |                     |                     |                     |
| O-ring for Adjustment Screw <sup>(2)</sup>               | 19 |                    |   |   |                     |                     |                     |
| O-ring for Electronics Cover<br>(Kit contains 20 each)   | 2  | 2                  |   | C | 01153-0039-0001     | 01153-0039-0001     | 01153-0039-0001     |
| O-ring for Electronics Cover<br>(Kit contains 1 each)    | 2  | 2                  |   | C | 01153-0039-0003     | 01153-0039-0003     | 01153-0039-0003     |
| O-ring for Process Flange, SST<br>(Kit contains 6 each)  | 11 | 2                  | X | B | 01153-0249-0001     | 01153-0249-0001     | 01153-0249-0001     |
| D.C. 55 O-ring Lubricant (0.25 oz)                       |    |                    |   |   | 01153-0053-0001     | 01153-0053-0001     | 01153-0053-0001     |
| D.C. 55 O-ring Lubricant (5.3 oz)                        |    |                    |   |   | 01153-0248-0001     | 01153-0248-0001     | 01153-0248-0001     |
| Loctite 580-PST Thread<br>Sealant (50 ml)                |    |                    |   |   | 01153-0329-0001     | 01153-0329-0001     | 01153-0329-0001     |
| Lubri-Bond A Cover Lubricant (12 oz)                     |    |                    |   |   | 01153-0333-0001     | 01153-0333-0001     | 01153-0333-0001     |

**NOTE**  
Kit includes  
2 SST O-rings.

Continued on Next Page

# Rosemount 1154

| Spare Parts Category <sup>(3)</sup>                             |      |   |   | Rosemount<br>1154DP | Rosemount<br>1154HP | Rosemount<br>1154GP |
|---|------|---|---|---------------------|---------------------|---------------------|
| Traceable Part  |      |   |   | Order No.           | Order No.           | Order No.           |
| Quantity Required   |      |   |   |                     |                     |                     |
| Item Number   |      |   |   | Order No.           | Order No.           | Order No.           |
| <b>Part Description</b>   |      |   |   |                     |                     |                     |
| Electronics Assembly Hardware                                   |      | 1 | A | 01153-0040-0001     | 01153-0040-0001     | 01153-0040-0001     |
| Electronics Screw (3)   | 7    |   |   |                     |                     |                     |
| Nameplate Screw (2)   |      |   |   |                     |                     |                     |
| Locknut   | 9    |   |   |                     |                     |                     |
| Jumper Wire Kit (36 in.)  |      |   |   | 01153-0055-0001     | 01153-0055-0001     | 01153-0055-0001     |
| Bolts and Nuts for Process Flange <sup>(3)</sup>                | 14/8 |   |   | 01153-0245-0001     | 01153-0245-0001     | 01153-0245-0001     |
| Range Codes 4–8 (Pkg of 4)                                      |      | 1 | X |                     |                     | 01153-0246-0001     |
| Range Code 9 (Pkg of 4)   |      | 1 | X | —                   | —                   | 01153-0246-0002     |
| Range Code 10 (Pkg of 4)  |      | 1 | X | —                   | —                   |                     |
| Panel Mounting Bracket with Bolts                               |      | 1 |   | 01153-0013-0001     | 01153-0013-0001     | 01153-0013-0001     |
| Universal Mounting Bracket with Bolts                           |      |   |   | 01153-0013-0003     | 01153-0013-0003     | 01153-0013-0003     |
| Bolts and Washers for Bracket (Pkg of 4)                        |      |   |   | 01153-0321-0001     | 01153-0321-0001     | 01153-0321-0001     |
| Pipe Mount Bracket Kit (Adapters)                               |      |   |   | 01154-0044-0001     | 01154-0044-0001     | 01154-0044-0001     |
| Pipe Mount Bracket Kit<br>(Bracket and Adapters)                |      |   |   | 01154-0038-0002     | 01154-0038-0002     | 01154-0038-0002     |
| Conduit Elbow (M22)   |      |   |   | 01154-0035-0001     | 01154-0035-0001     | 01154-0035-0001     |
| Conduit Elbow (½–14 NPT)  |      |   |   | 01154-0040-0001     | 01154-0040-0001     | 01154-0040-0001     |
| Amplifier Circuit Board, Output Code R,<br>N0026 <sup>(4)</sup> | 6    |   |   | 01154-0001-0006     | 01154-0001-0006     | —                   |

- (1) Rosemount recommends one spare part or kit for every 25 transmitters in Category “A,” one spare part or kit for every 50 transmitters in Category “B,” and one spare part or kit for every 5 transmitters in Category “C.”
- (2) Two flanges are required per transmitter. Flange parts depend on desired connection and transmitter type.
- (3) Each spare parts kit contains the correct number of nuts, bolts, and washers for the specific transmitter range code it is designated for. Due to consolidation of parts kits, the bolt length and quantity of washers required may differ from existing transmitter assemblies and/or parts kits. Verify by part number that the appropriate spare parts kit is used for the transmitter range code being re-assembled. Contact Rosemount Nuclear Instruments, Inc. if there are questions.
- (4) For use with existing N0026 transmitter only.

## SPARE PARTS SHELF LIFE

Store all spare transmitters and spare component parts in accordance with ANSI N45.2.2 level B.

Qualified transmitters, spare circuit boards, spare O-rings: the qualified life (as defined in Qualification Test Report D8400102) plus the shelf life is equal to the typical design life of the plant (40 years) when the ambient storage temperature is below 90 °F.

Lubricants and sealant: The date of the end of shelf life (use by date) is provided with the lubricants and/or sealant, at the time of shipment. The product has a minimum of six months shelf life at the time of shipment.

All other parts: Shelf life is not applicable.

## IMPORTANT NOTICE

There are factors to consider concerning maintenance of qualification and traceability during on-site instrument repair because of the nuclear use intended for these parts. Rosemount Nuclear Instruments, Inc. rigidly controlled the original assembly of the instrument to ensure that the specifications were met. Since we are not installing the replacement parts in the instruments, Rosemount Nuclear Instruments, Inc. is unable to ensure that the specifications are being satisfied. **Replacing parts has ramifications under 10CFR21, for which the user is responsible.** These same regulations additionally mandate a component traceability program, which the user must undertake for the replacement parts. In view of this, and in order to maintain the qualification of the product, the user must ensure that all replacement parts are installed in accordance with the Rosemount Nuclear Instruments, Inc. approved installation and calibration procedures herein.

### NOTES:

1. Rosemount 1154 spare parts are not hydrostatic tested or nuclear cleaned.
2. Part numbers shown may differ from those currently supplied. The part numbers shown are current at the time of printing of this manual, but may be revised in the future. Parts provided are compatible and interchangeable with those listed on your order as to the form, fit, and function of the part required. Please adjust your needs accordingly.





|                                 |           |  |  |
|---------------------------------|-----------|--|--|
| <b>A</b>                        |           |  |  |
| Adjustment                      | 3-7       |  |  |
| zero                            | 3-7       |  |  |
| <b>B</b>                        |           |  |  |
| BOARD CHECKOUT                  | 5-2       |  |  |
| <b>C</b>                        |           |  |  |
| Conduit                         | 2-4       |  |  |
| Conduit Connection              | 2-8       |  |  |
| Conduit Installation            | 2-8       |  |  |
| Connecting Electrical           |           |  |  |
| Housing to Sensor               | 5-7       |  |  |
| Connection, Conduit             | 2-8       |  |  |
| Connectors, Process             | 2-2       |  |  |
| Correction                      |           |  |  |
| zero                            | 3-7       |  |  |
| CORRECTION FOR                  |           |  |  |
| HIGH LINE PRESSURE              | 3-6       |  |  |
| Current Control                 | 4-4       |  |  |
| Current Limit                   | 4-4       |  |  |
| <b>D</b>                        |           |  |  |
| Damping Adjustment              | 3-5       |  |  |
| Demodulator                     | 4-3       |  |  |
| Differential                    |           |  |  |
| transmitter                     | 2-3, 2-4  |  |  |
| DISASSEMBLY                     |           |  |  |
| PROCEDURE                       | 5-4       |  |  |
| Drain/Vent Valves               | 2-3       |  |  |
| <b>E</b>                        |           |  |  |
| Electrical Connection Procedure | 2-8       |  |  |
| Electrical Considerations       |           |  |  |
| Grounding                       | 2-5       |  |  |
| Electrical Housing Disassembly  | 5-6       |  |  |
| Electrical Housing Reassembly   | 5-7       |  |  |
| ELECTRICAL INSTALLATION         | 2-8       |  |  |
| Errors                          |           |  |  |
| minimizing in                   |           |  |  |
| measurements                    | 2-4       |  |  |
| Exploded View                   |           |  |  |
| Rosemount 1154DP                | 5-5       |  |  |
| <b>F</b>                        |           |  |  |
| Flow                            | 2-3       |  |  |
| FUNCTIONAL                      |           |  |  |
| SPECIFICATIONS                  | 6-4       |  |  |
| <b>G</b>                        |           |  |  |
| Gas                             | 2-4       |  |  |
| Grounding                       | 2-5       |  |  |
| signal wiring                   | 2-5       |  |  |
| transmitter case                | 2-5       |  |  |
| <b>H</b>                        |           |  |  |
| HIGH LINE PRESSURE              | 3-6       |  |  |
| Housing                         |           |  |  |
| grounding                       | 2-5       |  |  |
| <b>I</b>                        |           |  |  |
| Impulse                         | 2-3, 2-4  |  |  |
| Installation, Conduit           | 2-8       |  |  |
| Installation, Mechanical        | 2-6       |  |  |
| Introduction                    | 4-1       |  |  |
| <b>J</b>                        |           |  |  |
| Jumper Wire Placement           | 3-4       |  |  |
| <b>L</b>                        |           |  |  |
| Level                           | 2-4, 6-11 |  |  |
| Linearity Adjustment            | 3-4, 4-3  |  |  |
| <b>M</b>                        |           |  |  |
| Mounting                        |           |  |  |
| location considerations         | 2-2       |  |  |
| see also installation           |           |  |  |
| <b>N</b>                        |           |  |  |
| Nuclear Specifications          | 6-1       |  |  |
| <b>O</b>                        |           |  |  |
| Operation                       |           |  |  |
| Current Control                 | 4-4       |  |  |
| Current Limit                   | 4-4       |  |  |
| Demodulator                     | 4-3       |  |  |
| Linearity Adjustment            | 4-3       |  |  |
| Oscillator                      | 4-4       |  |  |
| Reverse Polarity                |           |  |  |
| Protection                      | 4-4       |  |  |
| The $\delta$ -Cell Sensor       | 4-3       |  |  |
| Voltage Regulator               | 4-4       |  |  |
| Zero and Span                   |           |  |  |
| Adjustments                     | 4-4       |  |  |
| ORDERING INFORMATION            | 6-8       |  |  |
| Oscillator                      | 4-4       |  |  |
| <b>P</b>                        |           |  |  |
| PERFORMANCE                     |           |  |  |
| SPECIFICATIONS                  | 6-2       |  |  |
| Physical Specifications         | 6-6       |  |  |
| POST-ASSEMBLY TESTS             | 5-9       |  |  |
| Potentiometer                   | 3-8       |  |  |
| Process                         |           |  |  |
| connections                     | 2-4, 3-8  |  |  |
| loosening and                   |           |  |  |
| retightening                    | 2-3       |  |  |
| line                            | 2-3       |  |  |
| taps                            | 2-4       |  |  |
| Process Connectors              | 2-7       |  |  |
| Process Flange Reassembly       | 5-8       |  |  |
| Process Flange Removal          | 5-4       |  |  |
| Purging                         | 2-4       |  |  |
| <b>R</b>                        |           |  |  |
| Removing Sensor Module          |           |  |  |
| from Electrical Housing         | 5-6       |  |  |
| Reverse Polarity Protection     | 4-4       |  |  |
| <b>S</b>                        |           |  |  |
| Sediment                        |           |  |  |
| in impulse tubing               | 2-3       |  |  |
| preventing deposits             | 2-3       |  |  |
| Signal                          |           |  |  |
| terminals                       | 2-8       |  |  |
| Span                            | 2-5       |  |  |
| Span Adjustment                 | 3-1       |  |  |
| Spare Parts Shelf Life          | 6-11      |  |  |
| Swagelok Tube Fittings          | 2-2       |  |  |
| installing                      | 2-2       |  |  |
| more information about          | 2-3       |  |  |
| <b>T</b>                        |           |  |  |
| Temperature                     | 2-3, 2-4  |  |  |
| storage                         | 6-11      |  |  |
| Terminals, Test                 | 5-2       |  |  |
| Test Terminals                  | 5-2       |  |  |
| The $\delta$ -Cell Sensor       | 4-3       |  |  |
| Torque References               | 5-9       |  |  |
| Torque Specifications           |           |  |  |
| drain/vent valves               | 2-3       |  |  |
| terminal screws                 | 2-8       |  |  |
| Traceability                    | 6-11      |  |  |
| Transmitter                     |           |  |  |
| terminal block                  | 2-9       |  |  |
| Troubleshooting                 | 5-9       |  |  |
| <b>V</b>                        |           |  |  |
| Vent/Drain valves               | 2-3       |  |  |
| Voltage Regulator               | 4-4       |  |  |
| <b>Z</b>                        |           |  |  |
| Zero                            | 3-7       |  |  |
| Zero Adjustment                 | 3-1       |  |  |
| Zero and Span Adjustments       | 4-4       |  |  |





*The Emerson logo is a trade mark and service mark of Emerson Electric Co.  
Rosemount, the Rosemount logotype, and Alphaline are registered trademarks of Rosemount, Inc.  
δ-Cell is a trademarks of Rosemount, Inc.  
Swagelok is a registered trademark of Swagelok Co.*

**Emerson Process Management**

**Rosemount Nuclear Instruments, Inc.**

8200 Market Boulevard  
Chanhassen, MN 55317 USA  
T (952) 949-5210  
F (952) 949-5201

 Rosemount Nuclear Instruments, Inc. satisfies all obligations coming from legislation to harmonize product requirements in the European Union.

