

Rosemount™ 1056

Intelligent Four-Wire Transmitter



Safety information

Your instrument purchase from Emerson is one of the finest available for your particular application. Emerson has designed and tested these instruments to meet many national and international standards. Experience indicates that its performance is directly related to the quality of the installation and knowledge of the user in operating and maintaining the instrument.

⚠ WARNING

Precautionary signs

Failure to observe precautionary signs may result in injury or death to personnel or cause damage to equipment. Follow all warnings, cautions, and instructions marked on or supplied with the product.

⚠ WARNING

Follow installation guidelines.

Failure to follow these installation guidelines could result in death or serious injury. If this equipment is used in a manner not specified by the manufacturer, then the protection it provides against hazards may be impaired.

Follow all warnings, cautions, and instructions marked on and supplied with the product.

Install equipment as specified in this document.

Ensure that only qualified personnel perform the installation, operation, and maintenance of the product.

Inform and educate your personnel in the proper installation, operation, and maintenance of the product.

Follow appropriate local and national codes.

If you do not understand any of the instructions, contact your Emerson representative for clarification.

⚠ WARNING

Electrical shock

Installation and servicing of this product may expose personnel to dangerous voltages.

Electrical installation must be in accordance with the National Electrical Code (ANSI/National Fire Protection Agency-70) and/or any other national or local codes.

The equipment is protected throughout by double insulation.

Disconnect main power, wired to separate power source, before servicing.

Ensure that all equipment doors are closed and protective covers are in place, except when maintenance is being performed by qualified personnel.

Signal wiring must be rated at least 240 V.

Non-metallic cable strain reliefs do not provide grounding between conduit connections. Use grounding type bushings and jumper wires.

Make sure that the instrument is connected and properly grounded through a three-wire power source.

Proper use and configuration is the operator's responsibility.

Install all protective equipment covers and safety ground leads after installation.

Operate only with front panel fastened and in place.

Disconnect and lock out power before connecting the power supply.

⚠ WARNING

Physical access

Unauthorized personnel may potentially cause significant damage to and/or misconfiguration of end users' equipment. This could be intentional or unintentional and needs to be protected against.

Physical security is an important part of any security program and fundamental to protecting your system. Restrict physical access by unauthorized personnel to protect end users' assets. This is true for all systems used within the facility.

NOTICE

Use only factory documented components for repair. Tampering or unauthorized substitution of parts and procedures can affect performance and cause unsafe operation of your process.

NOTICE

This product generates, uses, and can radiate radio frequency energy, and this can cause radio communication interference.

As temporarily permitted by regulation, this device has been tested for compliance within the limits of Class A computing devices, pursuant to subpart J of part 15 of Federal Communication Commission (FCC) rules, which are designed to take whatever measures may be required to correct the interference.

Contents

Chapter 1	Installation.....	7
	1.1 Unpack and inspect.....	7
	1.2 General installation information.....	7
	1.3 Mounting diagrams.....	8
Chapter 2	Wiring.....	15
	2.1 General wiring information.....	15
	2.2 Preparing conduit openings.....	16
	2.3 Preparing sensor cable.....	17
	2.4 Power, output, and sensor connections.....	17
Chapter 3	Navigating the display.....	29
	3.1 User interface.....	29
	3.2 Keypad.....	29
	3.3 Main display.....	30
	3.4 Menu system.....	33
Chapter 4	Start up the transmitter.....	35
Chapter 5	Programming the transmitter.....	39
	5.1 General programming information.....	39
	5.2 Changing start-up settings.....	39
	5.3 Choose temperature units and automatic/manual temperature compensation.....	41
	5.4 Configuring and ranging the current outputs.....	41
	5.5 Set security code.....	44
	5.6 Security access.....	45
	5.7 Using hold.....	45
	5.8 Resetting factory default settings.....	46
	5.9 Program alarm relays.....	47
Chapter 6	Programming measurements.....	55
	6.1 Introduction to programming measurements.....	55
	6.2 Program pH measurement.....	55
	6.3 Program oxidation reduction potential (ORP) measurement.....	59
	6.4 Program contacting conductivity measurement.....	61
	6.5 Program toroidal conductivity measurement.....	69
	6.6 Program chlorine measurement.....	74
	6.7 Program oxygen measurement.....	84
	6.8 Program ozone measurement.....	90
	6.9 Program turbidity measurement.....	92
	6.10 Program flow measurement.....	96
	6.11 Program current input measurement.....	98
Chapter 7	Calibration.....	105
	7.1 Calibrate pH sensors.....	105
	7.2 Calibrate oxidation reduction potential (ORP) sensors.....	109

7.3 Calibrate contacting conductivity sensors.....	110
7.4 Calibrate toroidal conductivity sensors.....	116
7.5 Chlorine calibration.....	119
7.6 Calibrate oxygen sensors.....	123
7.7 Calibrate ozone sensors.....	127
7.8 Zero sensor.....	128
7.9 Calibrate sensor in process.....	129
7.10 Calibrate temperature.....	129
7.11 Calibrate turbidity.....	131
7.12 Calibrate pulse flow sensors.....	136

1 Installation

1.1 Unpack and inspect

Procedure

Inspect the shipping container.

- If it is damaged, contact the shipper immediately for further instructions.
- If there is no apparent damage, unpack the container. Ensure all items shown on the packing list are present. If items are missing, notify Emerson immediately.

1.2 General installation information

⚠ WARNING

Electrical shock

Installation and servicing of this product may expose personnel to dangerous voltages.

Electrical installation must be in accordance with the National Electrical Code (ANSI/National Fire Protection Agency-70) and/or any other national or local codes.

The equipment is protected throughout by double insulation.

Disconnect main power, wired to separate power source, before servicing.

Ensure that all equipment doors are closed and protective covers are in place, except when maintenance is being performed by qualified personnel.

Signal wiring must be rated at least 240 V.

Non-metallic cable strain reliefs do not provide grounding between conduit connections. Use grounding type bushings and jumper wires.

Make sure that the instrument is connected and properly grounded through a three-wire power source.

Proper use and configuration is the operator's responsibility.

Install all protective equipment covers and safety ground leads after installation.

Operate only with front panel fastened and in place.

Disconnect and lock out power before connecting the power supply.

1. Install the transmitter with a sun shield or out of direct sunlight and areas with extreme temperatures.
2. Install the system in an area where vibrations and electromagnetic and radio frequency interference are minimized or absent.
3. Keep the transmitter and sensor wiring at least 1 ft (0.30 m) from high voltage conductors. Ensure there is easy access to the transmitter and sample conditioning system.
4. The transmitter is suitable for panel, pipe, or surface mounting.

1.3 Mounting diagrams

NOTICE

Dimensions in the following drawings show millimeters above and inches below.

Figure 1-1: Panel mount front

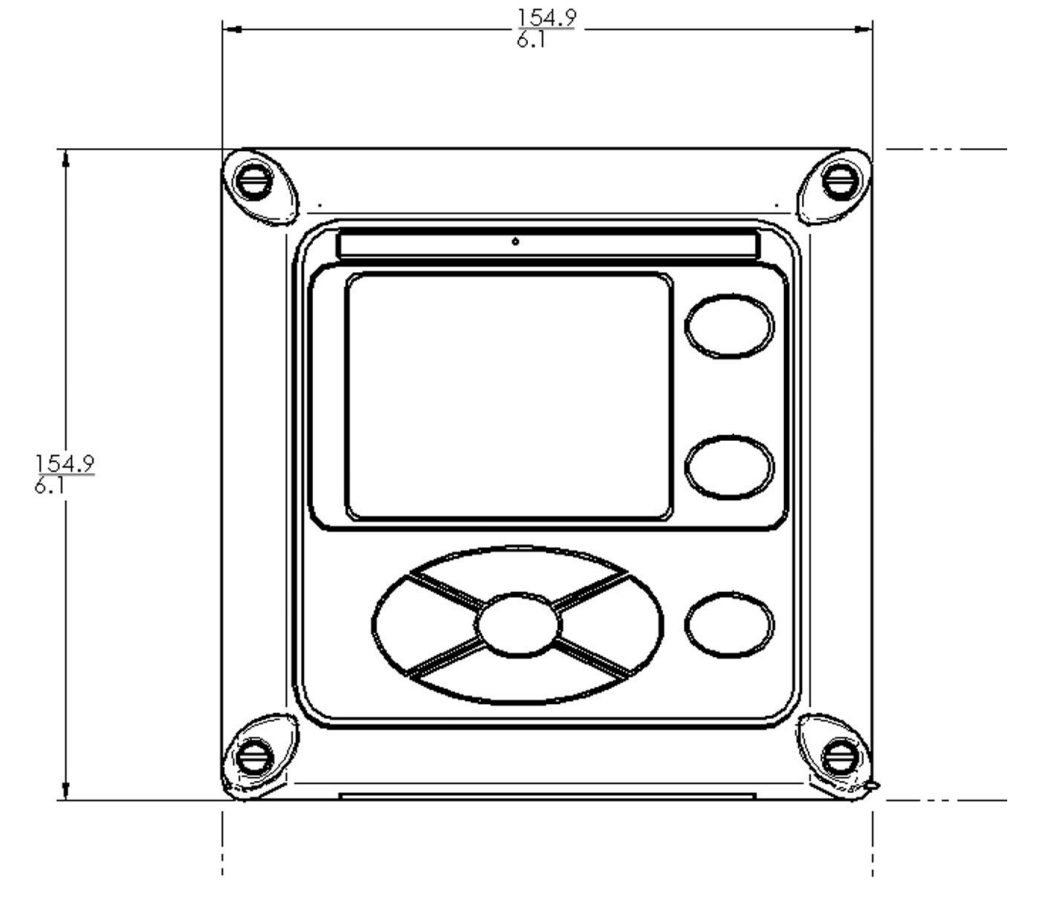
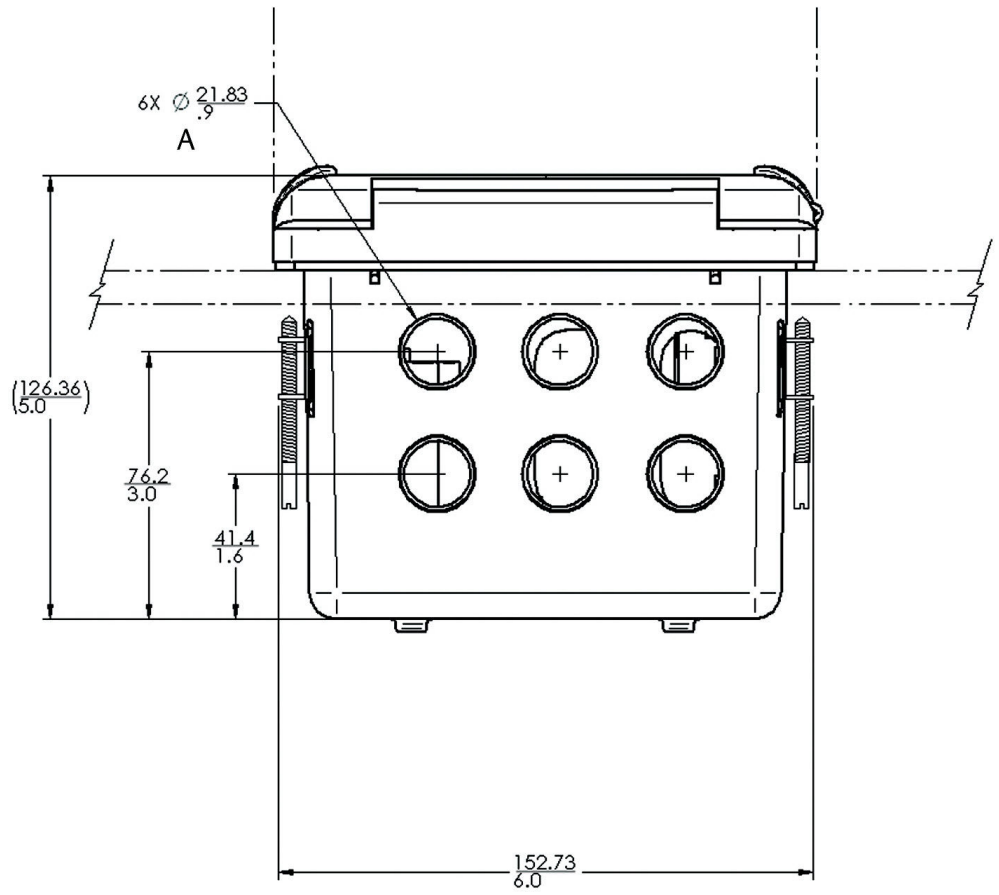
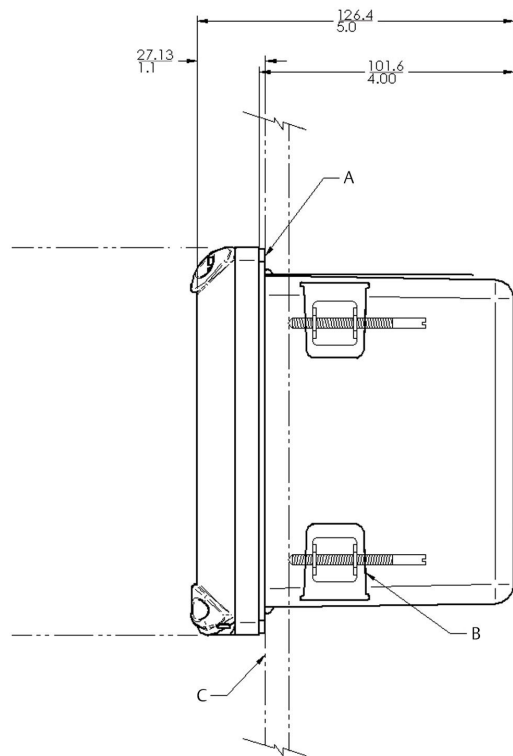

Figure 1-2: Panel mount bottom



A. Six conduit openings

Figure 1-3: Panel mount side



- A. Panel mount gasket
- B. Four mounting brackets and screws provided with transmitter
- C. Panel supplied by others: maximum thickness 0.375 in (9.52 mm)

Figure 1-4: Panel mount cut-out

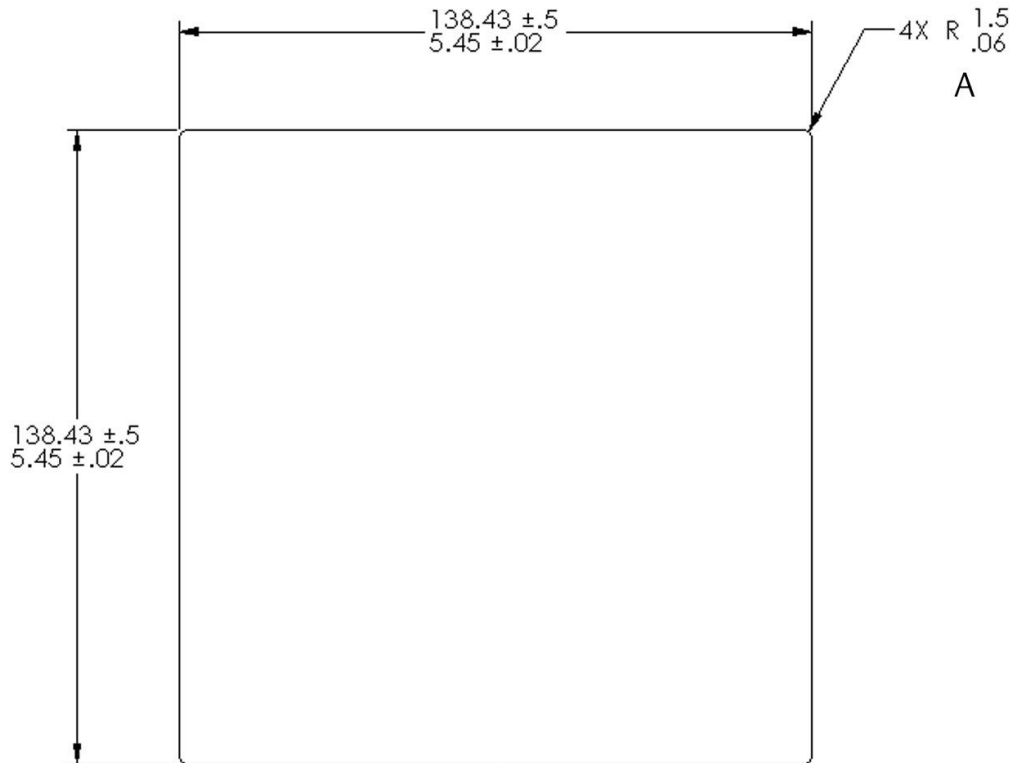

A. Maximum radius

Note

Panel mounting seal integrity (4/4X) for outdoor applications is the end user's responsibility.

Figure 1-5: Wall mount front

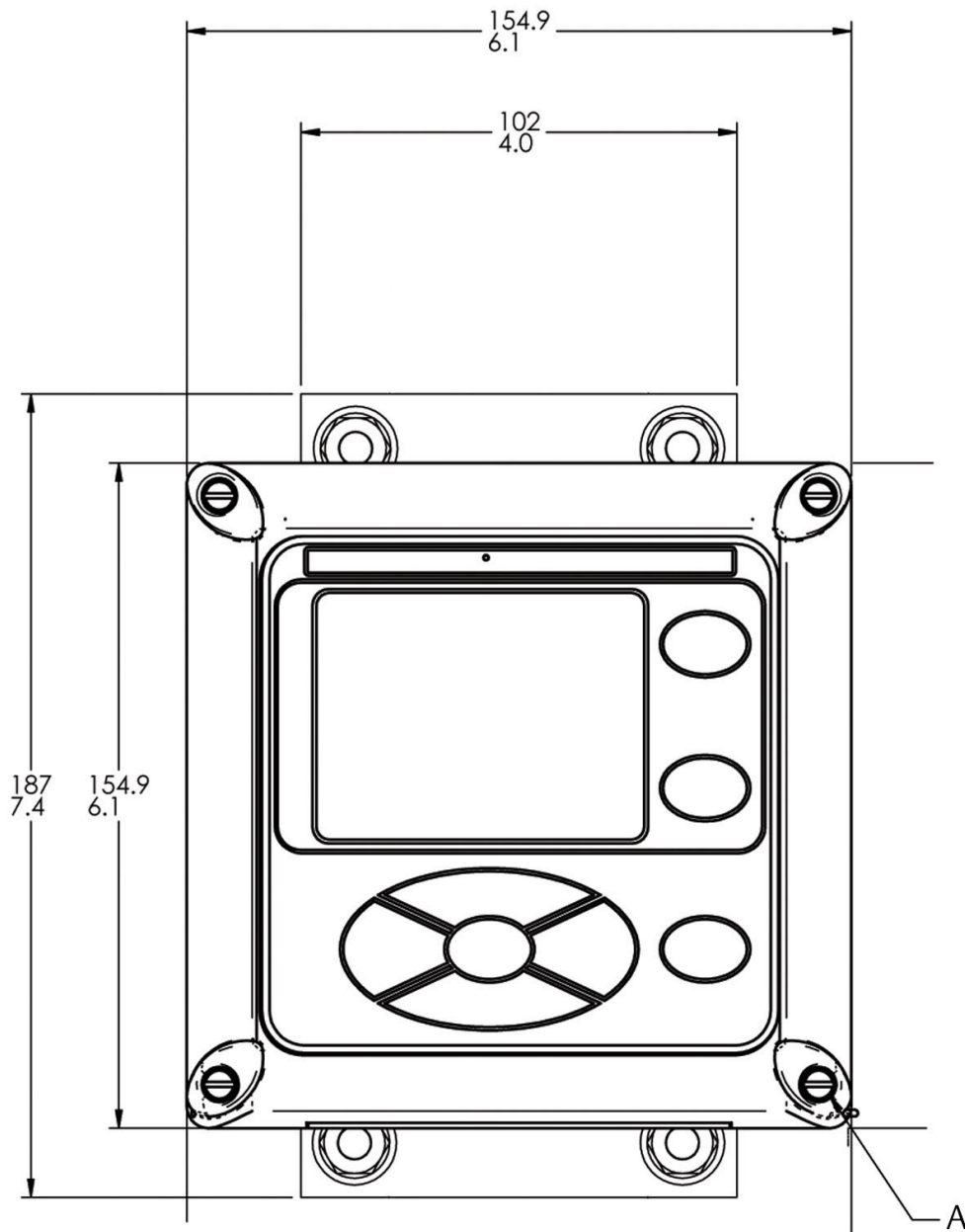

A. Four cover screws

Figure 1-6: Wall mount side

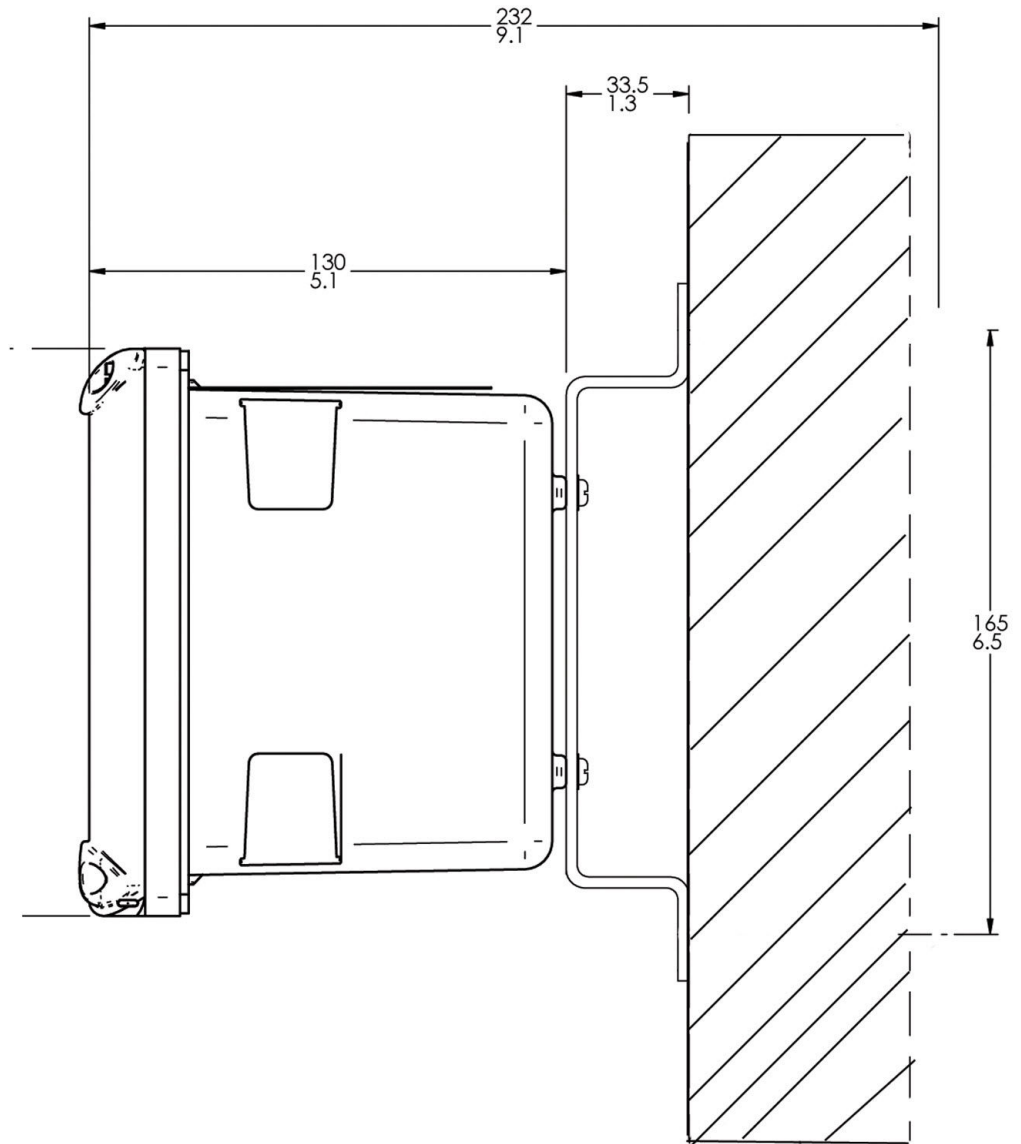
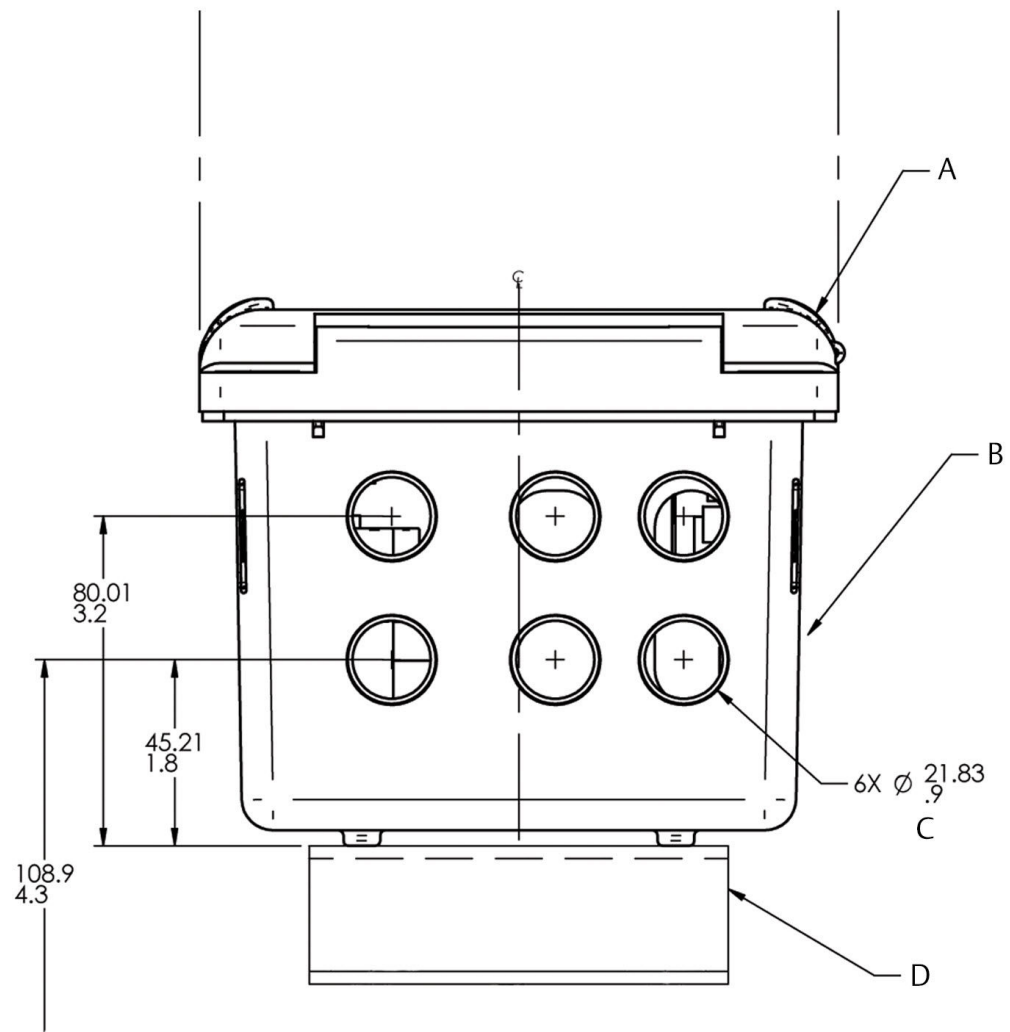

Figure 1-7: Pipe mount bottom



- A. Front panel
- B. Panel and pipe mount enclosure
- C. Conduit openings
- D. 2-in. (51 mm) pipe mount bracket

2 Wiring

2.1 General wiring information

The transmitter includes removable connectors and slide-out signal input boards for sensors. The front panel is hinged at the bottom. The panel swings down for easy access to the wiring locations.

2.1.1 Removable connectors and signal input boards

The transmitter uses removable signal input boards to facilitate wiring and installation. If using the Profibus® protocol, you need to use a communication board as well.

You can remove each of the signal boards either partially or completely from the enclosure for wiring. The transmitter has three slots for placement of up to two signal input boards and one communication board.

Slot 1 - left	Slot 2 - center	Slot 3 - right
Communication board (only for Profibus)	Input board 1	Input board 2

2.1.2 Wire the signal input boards

Slots 2 and 3 are for signal input measurement boards.

Procedure

1. Wire the sensor leads to the measurement board following the lead locations marked on the board.
2. Carefully slide the wired board fully into the enclosure slot and take up the excess sensor cable through the cable gland.
3. Tighten the cable gland nut to secure the cable and ensure a sealed enclosure.

2.1.3 Digital communication boards

HART® and Profibus® DP communication boards will be available in the future as options for Rosemount 1056 digital communication with a host.

The HART board supports Bell 202 digital communication over an analog 4-20 mA current output. Profibus DP is an open communication protocol that operates over a dedicated digital line to the host.

2.1.4 Alarm relays

Emerson supplies four dry contact alarm relays with the switching power supply (85 to 264 Vac, 03 order code) and the 24 Vdc power supply (20 - 30 Vdc, 02 order code). You can use all relays for process measurement(s) or temperature. You can also configure any relay as a fault alarm instead of a process alarm. In addition, you may configure any relay independently and program it to activate pumps or control valves.

All process alarms, alarm logic (high or low activation or user-selectable percentage [USP*]), and deadband are user-programmable. You may program the USP* alarm to

activate when the conductivity is within a user-selectable percentage of the limit. USP* alarming is available only when a contacting conductivity measurement board is installed.

2.2 Preparing conduit openings

There are six conduit openings in all configurations of the transmitter.

Note

Emerson fits four of the openings with plugs upon shipment.

Figure 2-1: Conduit openings

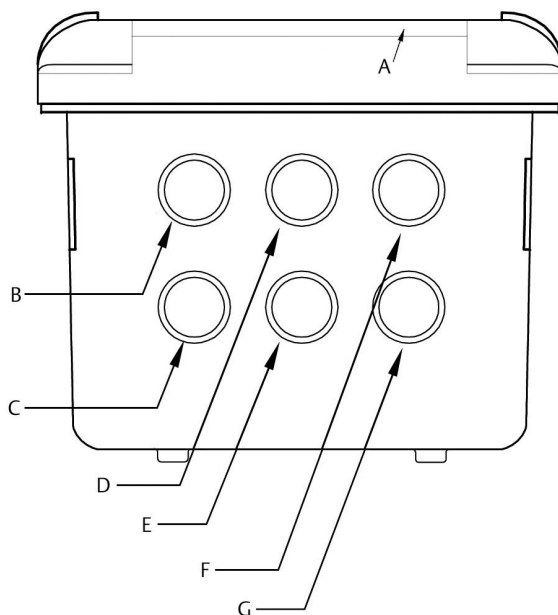

- A. Front panel/keypad
- B. Power leads
- C. Alarm relay leads
- D. Sensor 1 cable
- E. 4-20 mA/HART®/Profibus® leads
- F. Sensor 2 cable
- G. Spare opening

NOTICE

Always use proper cable gland fittings and plugs for wire and cable installations.

Conduit openings accept 0.5 in (13 mm) conduit fittings or PG13.5 cable glands. To keep the case watertight, block unused openings with Type 4X or IP66 conduit plugs.

NOTICE

Use watertight fittings and hubs that comply with your requirements. Connect the conduit hub to the conduit before attaching the fitting to the transmitter.

2.3 Preparing sensor cable

The Rosemount 1056 is intended for use with all Rosemount sensors. Refer to the sensor Quick Start Guide for details on preparing sensor cables.

2.4 Power, output, and sensor connections

2.4.1 Power wiring

Emerson offers three power supplies for the Rosemount 1056.

- 115/230 Vac power supply (01 ordering code)
- 24 Vdc (20-30 V) power supply (02 ordering code)
- 85-265 Vac switching power supply (03 ordering code)

AC mains (115 or 230 V) leads and 24 Vdc leads are wired to the power supply board, which is mounted vertically on the left side of the main enclosure cavity. Each lead location is marked clearly on the power supply board. Wire the power leads to the power supply board using the lead markings on the board.

The grounding plate is connected to the earth terminal of power supply input connector TB1 on the 01 (115/230 Vac) and 03 (85-265 Vac) power supplies. The green screws on the grounding plate are intended for connection to some sensors to minimize radio frequency interference. The green screws are not intended to be used for safety purposes.

Figure 2-2: 115/230 Vac power supply (01 ordering code)

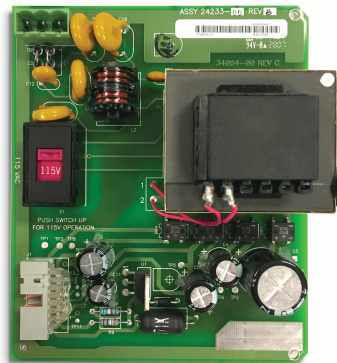

NOTICE

The AC power switch is shipped in the 230 Vac position. Adjust the switch upwards to the 115 Vac position for 110 Vac to 120 Vac operation.

Figure 2-3: 24 Vdc power supply (02 ordering code)

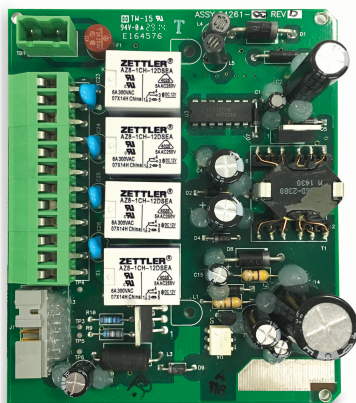

This power supply automatically detects DC power and accepts 20 Vdc to 30 Vdc inputs. Four programmable alarm relays are included.

Figure 2-4: Switching AC power supply (03 ordering code)

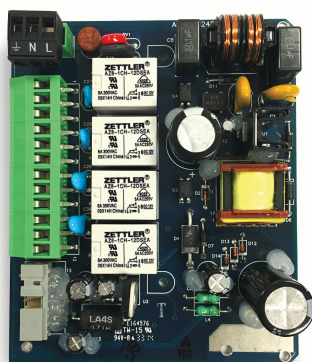

This power supply automatically detects AC line conditions and switches to the proper line voltage and line frequency.

Four programmable relays are included.

2.4.2 Current output wiring

Wiring locations for the outputs are on the main board, which is mounted on the hinged door of the transmitter. Wire the relay leads on each of the independent relays to the correct position on the main board using the lead markings (+/positive, -/negative) on the board. Emerson provides male mating connectors with each unit.

NOTICE

Twisted pairs are required to minimize noise pickup in the flow and current sensor inputs. For high electromagnetic interference/radio frequency interference (EMI/RFI) environments, use shielded sensor wire. Emerson also recommends using shielded sensor wire in other installations.

Figure 2-5: Current output wiring

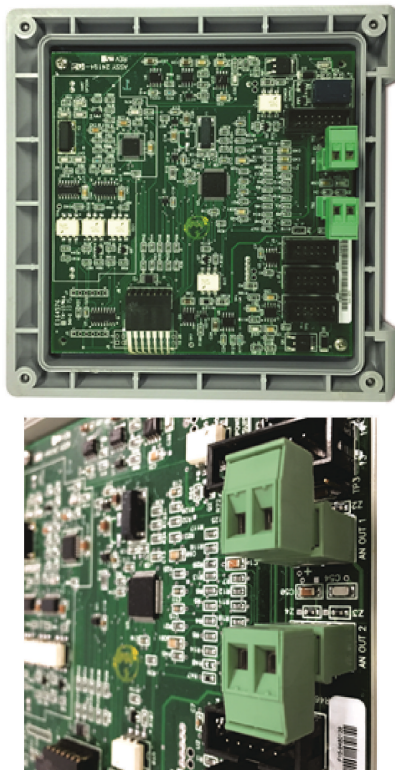

2.4.3 Alarm relay wiring

Emerson supplies four alarm relays with the switching power supply (85 to 265 Vac, 03 order code) and the 24 Vdc power supply (20-30 Vdc, 02 order code).

Wire the relay leads on each of the independent relays to the correct position on the power supply board using the printed lead markings (**NO**/Normally open, **NC**/Normally closed, or **Com**/Common) on the board. See [Figure 2-6](#)

Figure 2-6: Alarm relay wiring for Rosemount 1056 switching power supply (03 ordering code)

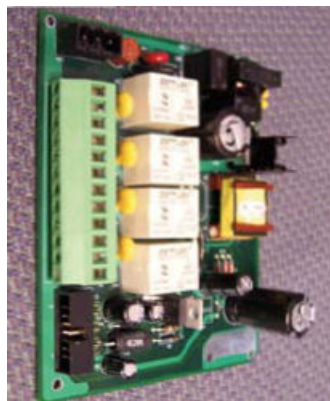

Table 2-1: Relays

NO1	Relay 1
COM1	
NC1	
NO2	Relay 2
COM2	
NC2	
NO3	Relay 3
COM3	
NC3	
NO4	Relay 4
COM4	
NC4	

2.4.4 Wire sensor to signal boards

Procedure

1. Wire the correct sensor leads to the main board using the lead locations marked directly on the board.
2. Carefully slide the wired board fully into the enclosure slot and take up the excess sensor cable through the cable gland.
For best electromagnetic interference (EMI) and radio frequency interference (RFI) protection, use shielded output signal cable enclosed in an earth-grounded metal conduit. AC wiring should be 14 gauge or greater.
3. Provide a switch or breaker to disconnect the transmitter from the main power supply. Install the switch or breaker near the transmitter and label it as the disconnecting device for the transmitter.

⚠ WARNING

Electrical shock

Installation and servicing of this product may expose personnel to dangerous voltages.

Electrical installation must be in accordance with the National Electrical Code (ANSI/National Fire Protection Agency-70) and/or any other national or local codes.

The equipment is protected throughout by double insulation.

Disconnect main power, wired to separate power source, before servicing.

Ensure that all equipment doors are closed and protective covers are in place, except when maintenance is being performed by qualified personnel.

Signal wiring must be rated at least 240 V.

Non-metallic cable strain reliefs do not provide grounding between conduit connections. Use grounding type bushings and jumper wires.

Make sure that the instrument is connected and properly grounded through a three-wire power source.

Proper use and configuration is the operator's responsibility.

Install all protective equipment covers and safety ground leads after installation.

Operate only with front panel fastened and in place.

Disconnect and lock out power before connecting the power supply.

Keep sensor and output signal wiring separate from loop power wiring. Do not run sensor and power wiring in the same conduit or close together in a cable tray.

NOTICE

Twisted pairs are required to minimize noise pickup in the flow and current sensor inputs. For high electromagnetic interference/radio frequency interference (EMI/RFI) environments, use shielded sensor wire. Emerson also recommends using shielded sensor wire in other installations.

Figure 2-7: Contacting conductivity signal board and sensor cable leads



Figure 2-8: Toroidal conductivity signal board and sensor cable leads

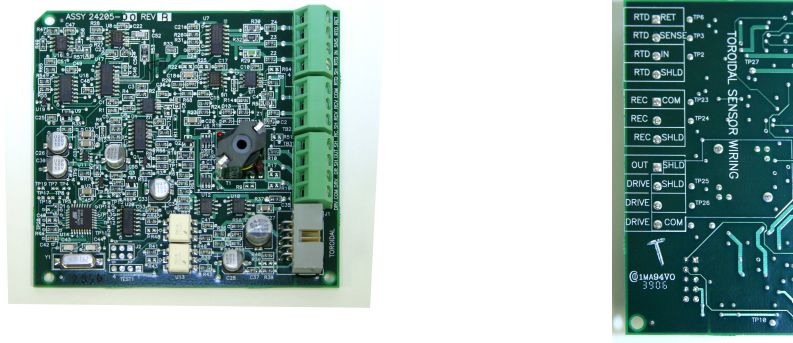

Figure 2-9: pH/ORP signal board and sensor cable leads

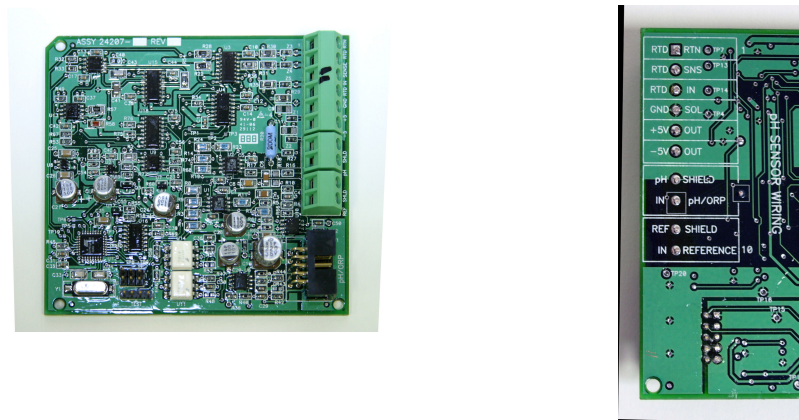

Figure 2-10: Chlorine, dissolved oxygen, and ozone signal boards and sensor cable leads

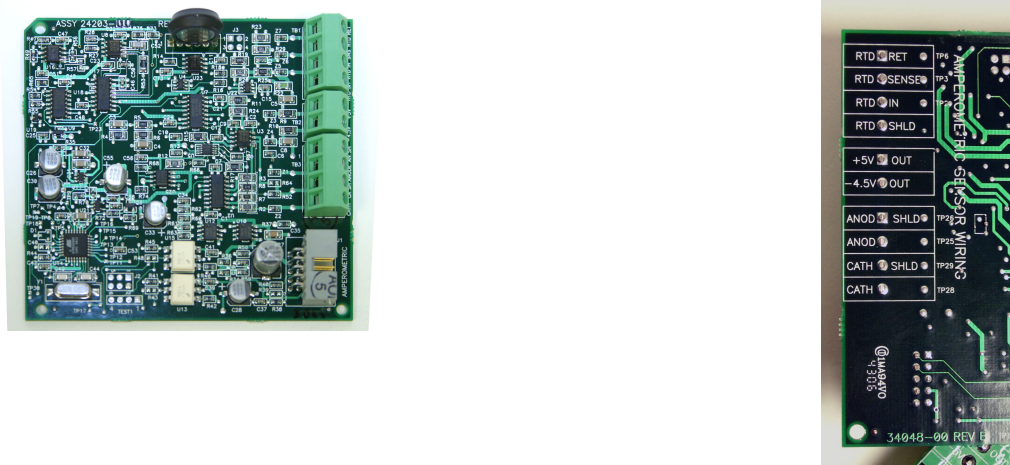

Figure 2-11: Turbidity signal board with plug-in sensor connection

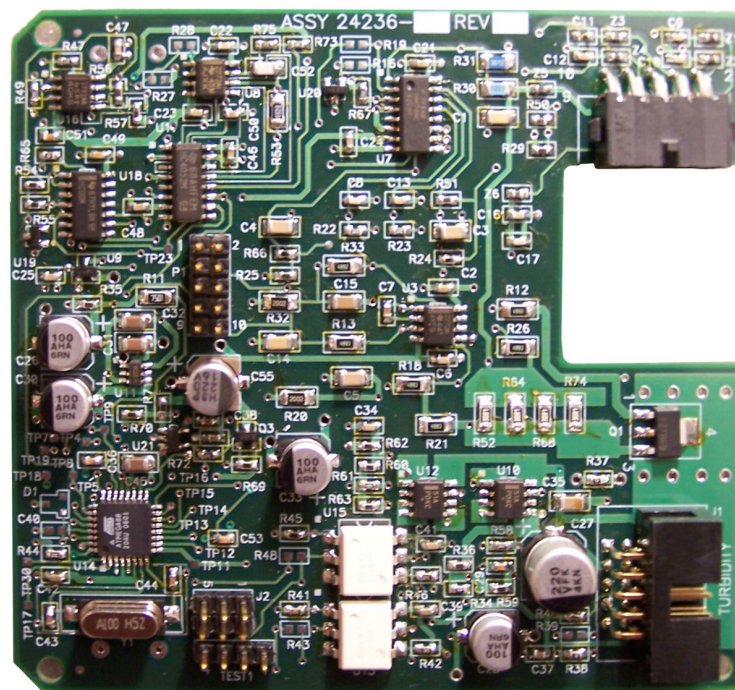

Figure 2-12: Flow/current input signal board and sensor cable leads

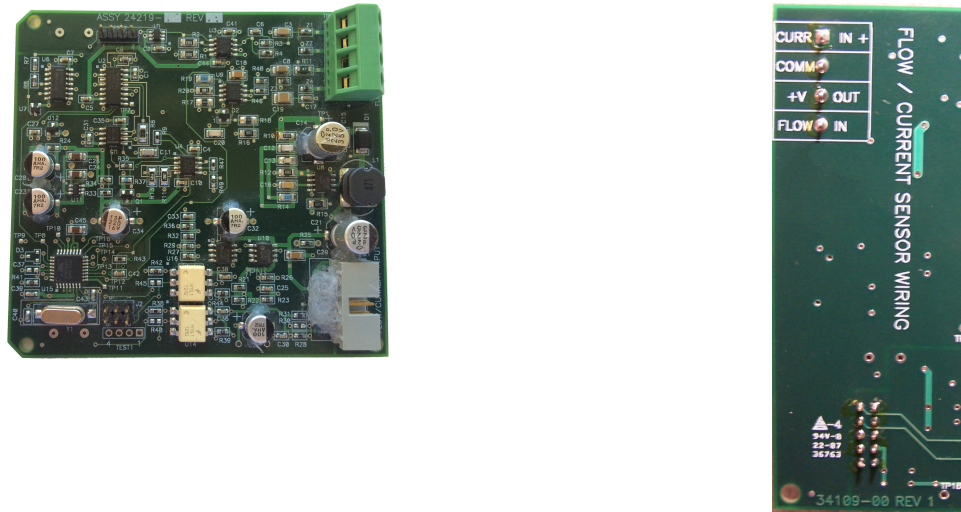
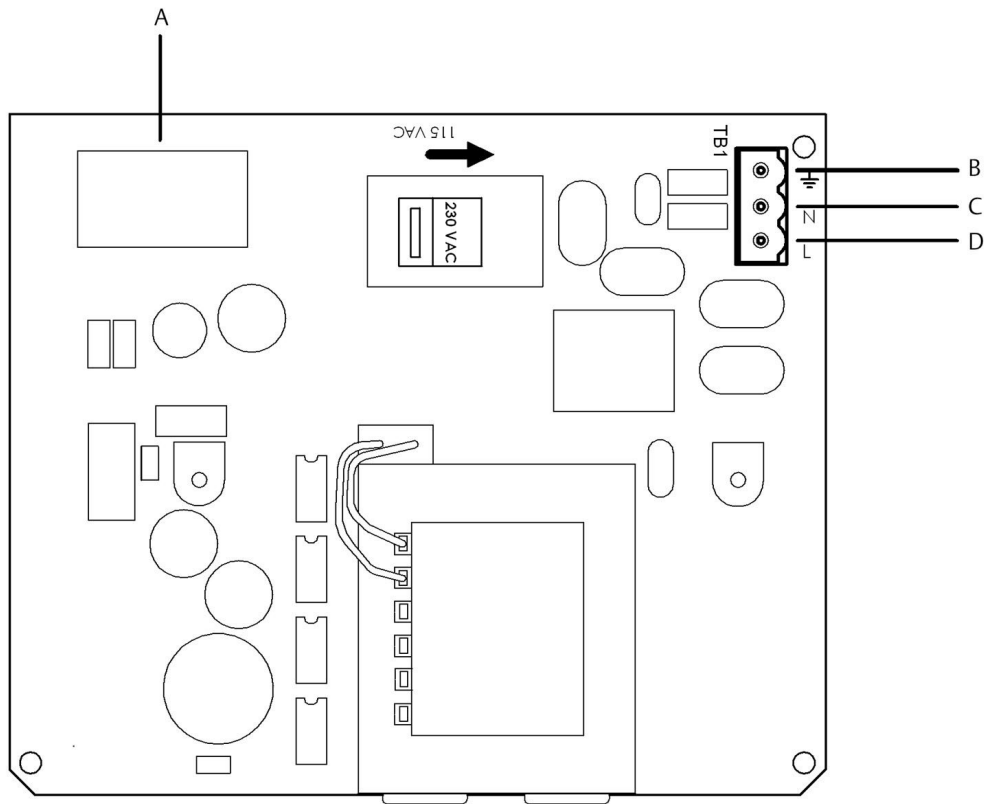
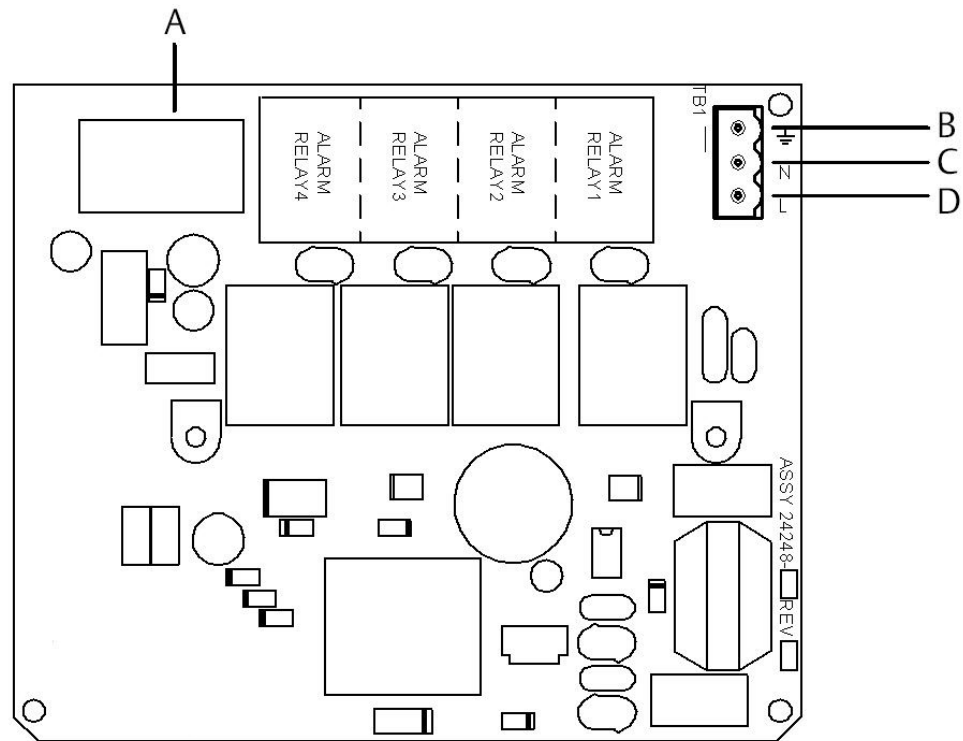

Figure 2-13: Power wiring for the Rosemount 1056 115/230 Vac power supply (01 order code)



- A. To main board
- B. Earth ground
- C. Neutral
- D. Line

Figure 2-14: Power wiring for the Rosemount 1056 85-265 Vac power supply (03 ordering code)



- A. To main board
- B. Earth ground
- C. Neutral
- D. Line

Figure 2-15: Output wiring for Rosemount 1056 main PCB

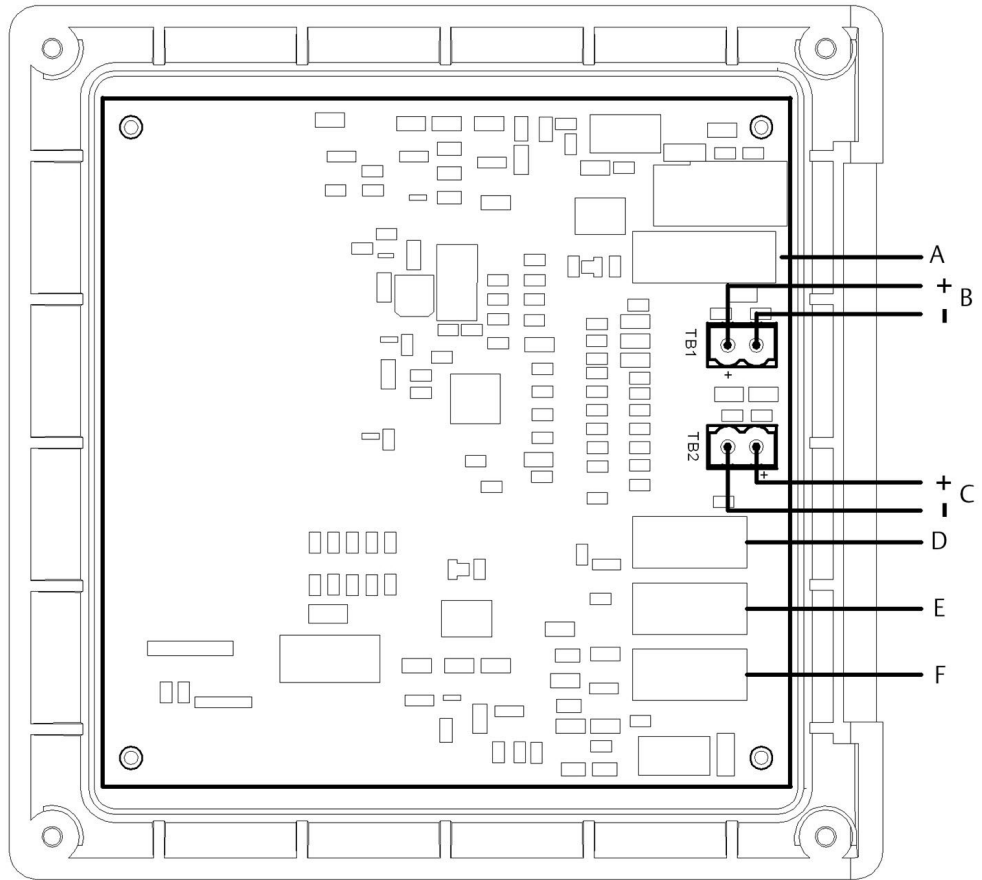

- A. To power supply PCB
- B. Analog output 1
- C. Analog output 2
- D. To digital input/output PCB
- E. To sensor 1 PCB
- F. To sensor 2 PCB

Figure 2-16: Power wiring for Rosemount 1056 24 Vdc power supply (02 ordering code)

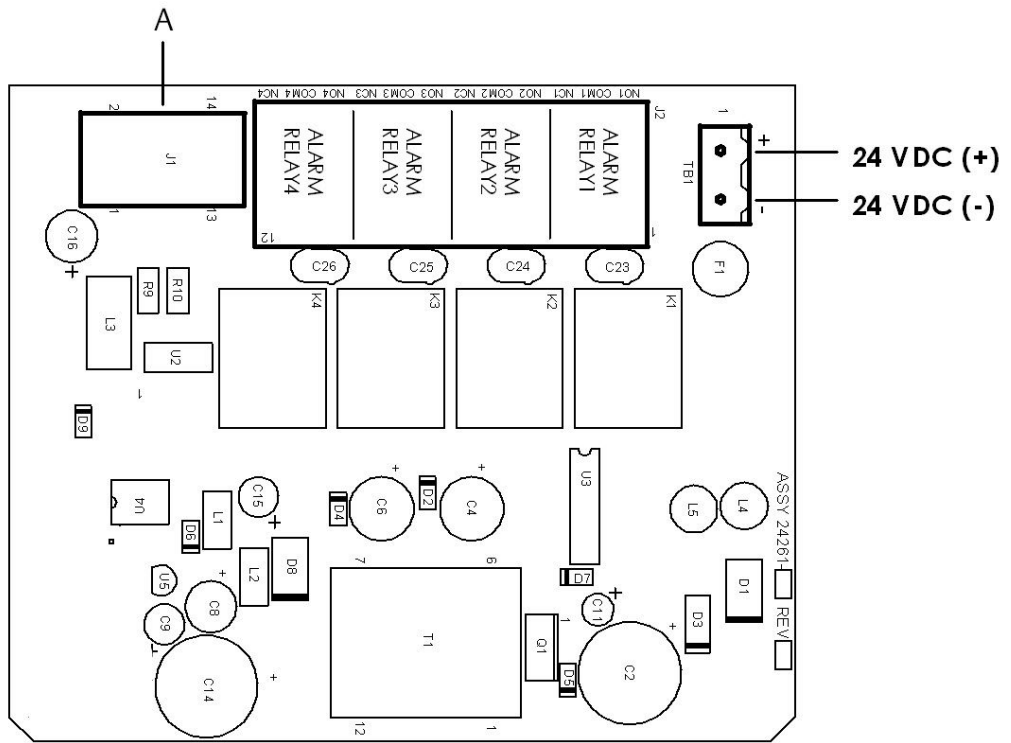

A. To main board

3 Navigating the display

3.1 User interface

The Rosemount 1056 has a large display which shows two live measurement readouts in large digits and up to four additional process variables or diagnostic parameters concurrently. The display is back-lit, and you can customize the format to meet your requirements.

Press **MENU** to access calibration, hold (of current outputs), programming, and display functions. In addition, a dedicated **DIAGNOSTIC** button is available to provide access to useful operational information on installed sensor(s) and any problematic conditions that might occur. The display flashes *Fault* and/or *Warning* when these conditions occur.

The transmitter displays **Help** screens for most fault and warning conditions to guide you in troubleshooting. During calibration and programming, key presses cause different displays to appear. The displays are self-explanatory and guide you step-by-step through the procedure.



3.2 Keypad

Press **MENU** to access menus for programming and calibrating the transmitter. There are four function keys and four selection keys on the keypad.

Function keys

Four top-level menu items appear when you press **MENU**.

- Calibrate** Calibrate the attached sensor(s) and analog output(s).
- Hold** Suspend analog output(s).
- Program** Program outputs, measurement, temperature, security, and reset.
- Display** Program display format, language, warnings, and contrast.

Press **MENU** to display the main menu screen. Press **MENU** followed by **EXIT** to display the main display.

Press **DIAG** to display active Faults and Warnings and detailed transmitter information and sensor diagnostics, including:

- Faults
- Warnings

- Sensor 1 and 2 information
- Output 1 and 2 live current values
- Transmitter software version
- AC frequency

Press **ENTER** on Sensor 1 or Sensor 2 to display useful diagnostics and information, such as:

- Measurement
- Sensor type
- Raw signal value
- Cell constant
- Zero offset
- Temperature
- Temperature offset
- Selected measurement range
- Cable resistance
- Temperature sensor resistance
- Signal board software version

Press **ENTER** to store numbers and settings and move the display to the next screen.

Press **EXIT** to return to the previous screen without storing changes.

Selection keys

Surrounding the **ENTER** key, four selection keys (**Up**, **Down**, **Right**, and **Left**) move the cursor to all areas of the screen while using the menus.

Use selection keys to:

- Select items on the menu screens.
- Scroll up and down the menu lists.
- Enter or edit numeric values.
- Move the cursor to the right or left.
- Select measurement units during operation.

3.3 Main display

The Rosemount 1056 displays:

- One or two primary measurement values
- Up to four secondary measurement values
- Fault and Warning banner
- Alarm relay flags
- Digital communication icon

Process measurements

Two process variables are displayed if two signal boards are installed. One process variable and process temperature are displayed if one signal board is installed with one sensor. The upper display area shows the Sensor 1 process reading. The center display area shows the Sensor 2 process reading. For dual conductivity, you can assign the upper and center display areas to different process variables as follows:

Process variables for upper display	Process variables for center display
Measure 1	Measure 1
% Reject	Measure 2
% Pass	% Reject
Ratio	% Pass
	Ratio
	Blank

For single input configurations, the upper display area shows the live process variable, and you can assign the center display area to Temperature or blank.

Secondary values

Up to four secondary values are shown in display quadrants at the bottom half of the screen. You can program all four secondary value positions to any displayable parameter available.

Possible secondary values include:

- Slope 1
- Reference off 1
- GI impedance 1
- Reference impedance 1
- Raw
- mV input
- Temperature 1
- Manual temperature 1
- Manual temperature 2
- Output 1 mA
- Output 2 mA
- Output 1%
- Output 2%
- Measure 1
- Relay 1⁽¹⁾
- Relay 2⁽¹⁾
- Relay 3⁽¹⁾
- Relay 4⁽¹⁾

⁽¹⁾ Only for the 1056-02 or 1056-03.

- Blank

Fault and Warning banner

If the transmitter detects a problem with itself or the sensor, the word `Fault` or `Warning` will appear at the bottom of the display. A fault requires immediate attention. A warning indicates a problematic condition or an impending failure. For troubleshooting assistance, press **DIAG**.

Formatting the main display

You can program the main display screen to show primary process variables, secondary process variables, and diagnostics.

1. Press **MENU**.
2. Scroll down to `Display`. Press **ENTER**.
3. `Main Format` is highlighted. Press **ENTER**.
4. The Sensor 1 process value is highlighted in reverse video. Press the selection keys to navigate down to the screen sections that you wish to program. Press **ENTER**.
5. Choose the desired display parameter or diagnostic for each of the four display sections in the lower screen.
6. Continue to navigate and program all desired screen selections. Press **MENU** and **EXIT**. The screen returns to the main display.

For single sensor configurations, the default display shows the live process measurement in the upper display area and temperature in the center display area. You can elect to disable the display of temperature in the center display area using the Main Format function. For dual sensor configurations, the default display shows Sensor 1 live process measurement in the upper display area and Sensor 2 live process measurement in the center display area.

Figure 3-1: Formatting the main display

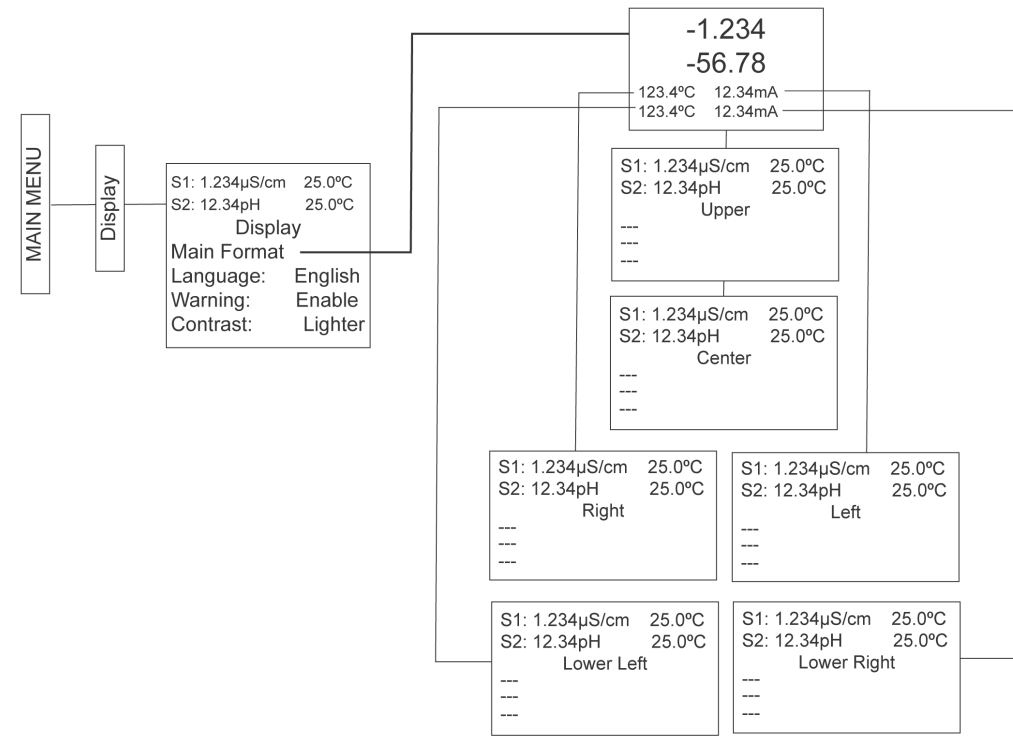

3.4 Menu system

The transmitter uses a scroll and select menu system. Press **MENU** at any time to open the top-level menu, including Calibrate, Hold, Program, and Display functions.

To find a menu item, scroll with the **Up** and **Down** keys until the item is highlighted. Continue to scroll and select menu items until the desired function is chosen. To select the menu item, press **ENTER**. To return to a previous menu level or to enable the main live display, press **EXIT** repeatedly. To return immediately to the main display from any menu level, press **MENU** and then **EXIT**.

The selection keys have the following functions:

- The **Up** key (above **ENTER**) increments numerical values, moves the decimal point one place to the right, or selects units of measurement.
- The **Down** key (below **ENTER**) decrements numerical values, moves the decimal point one place to the left, or selects units of measurement.
- The **Left** key (left of **ENTER**) moves the cursor to the left.
- The **Right** key (right of **ENTER**) moves the cursor to the right.

During all menu displays (except main display format and **Quick Start**), the live process measurements and secondary measurement values are displayed in the top two lines of the upper display area. This conveniently allows display of the live values during important calibration and programming operations.

Menu screens time out after two minutes and return to the main display.

4 Start up the transmitter

Procedure

1. Wire sensor(s) to the signal boards.
Refer to the sensor Quick Start Guide for additional details. Make current output, alarm relay, and power connections.
2. Once connections are secured and verified, apply power to the transmitter.

⚠ WARNING

Electrical shock

Installation and servicing of this product may expose personnel to dangerous voltages.

Electrical installation must be in accordance with the National Electrical Code (ANSI/National Fire Protection Agency-70) and/or any other national or local codes.

The equipment is protected throughout by double insulation.

Disconnect main power, wired to separate power source, before servicing.

Ensure that all equipment doors are closed and protective covers are in place, except when maintenance is being performed by qualified personnel.

Signal wiring must be rated at least 240 V.

Non-metallic cable strain reliefs do not provide grounding between conduit connections. Use grounding type bushings and jumper wires.

Make sure that the instrument is connected and properly grounded through a three-wire power source.

Proper use and configuration is the operator's responsibility.

Install all protective equipment covers and safety ground leads after installation.

Operate only with front panel fastened and in place.

Disconnect and lock out power before connecting the power supply.

When the transmitter is powered up for the first time, **Quick Start** screens appear. Quick Start operating tips are as follows:

- a. A back-lit field shows the position of the cursor.
 - b. To move the cursor left or right, use the keys to the left or right of the **ENTER** key. To scroll up or down or to increase or decrease the value of a digit, use the keys above and below the **ENTER** key. Use the **Left** or **Right** keys to move the decimal point.
 - c. Press **ENTER** to store a setting. Press **EXIT** to leave without storing changes. Press **EXIT** during Quick Start to return the display to the initial startup screen (**Select language**).
3. Complete the steps as shown in the [Figure 4-1](#).

Figure 4-1: Quick start flow diagram

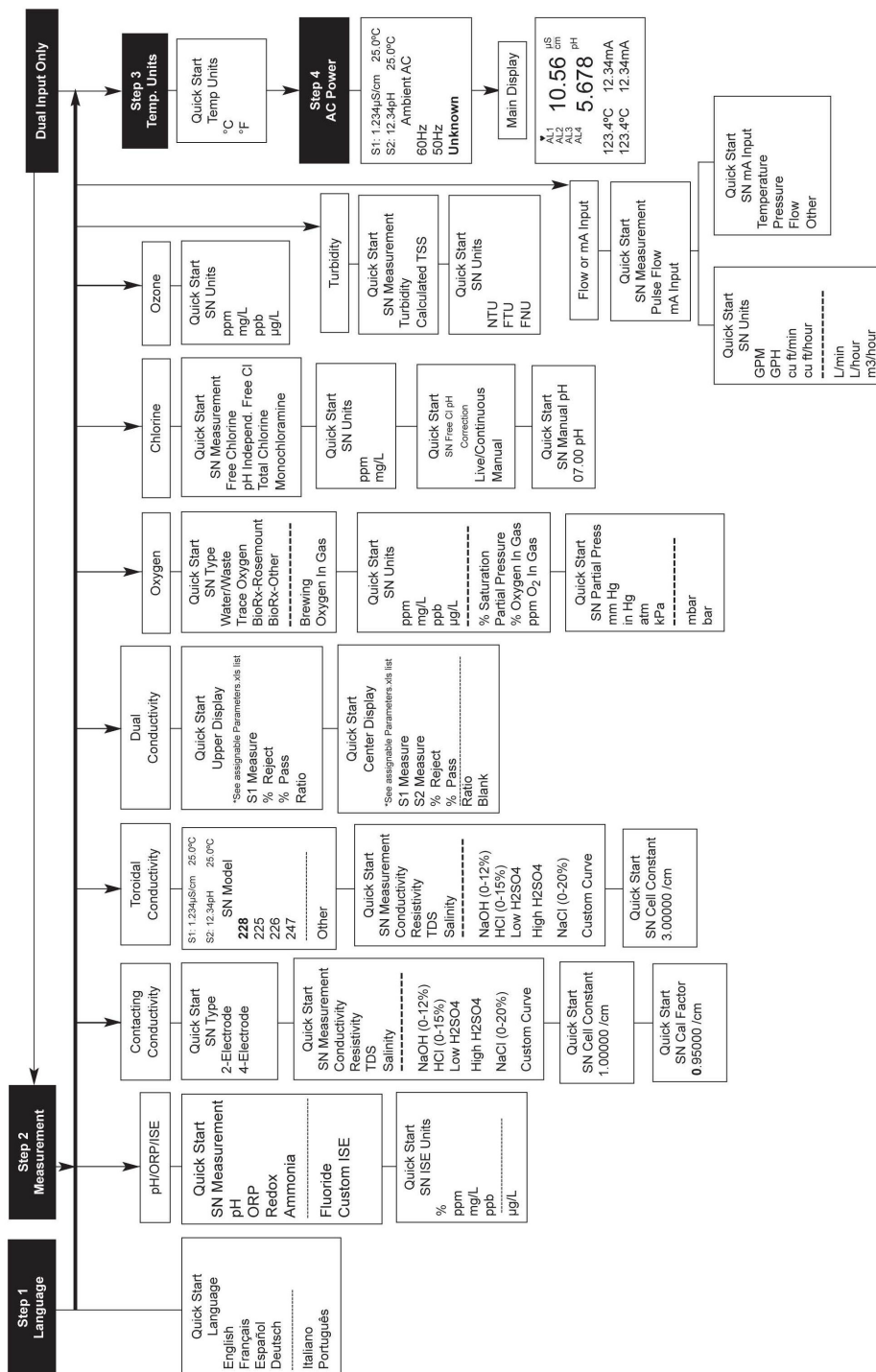

After the last step, the main display appears. The outputs are assigned to default values.

- To change output and temperature-related settings, go to **Main Menu** → **Program**. Follow the prompts.

Figure 4-2: Rosemount 1056 menu tree

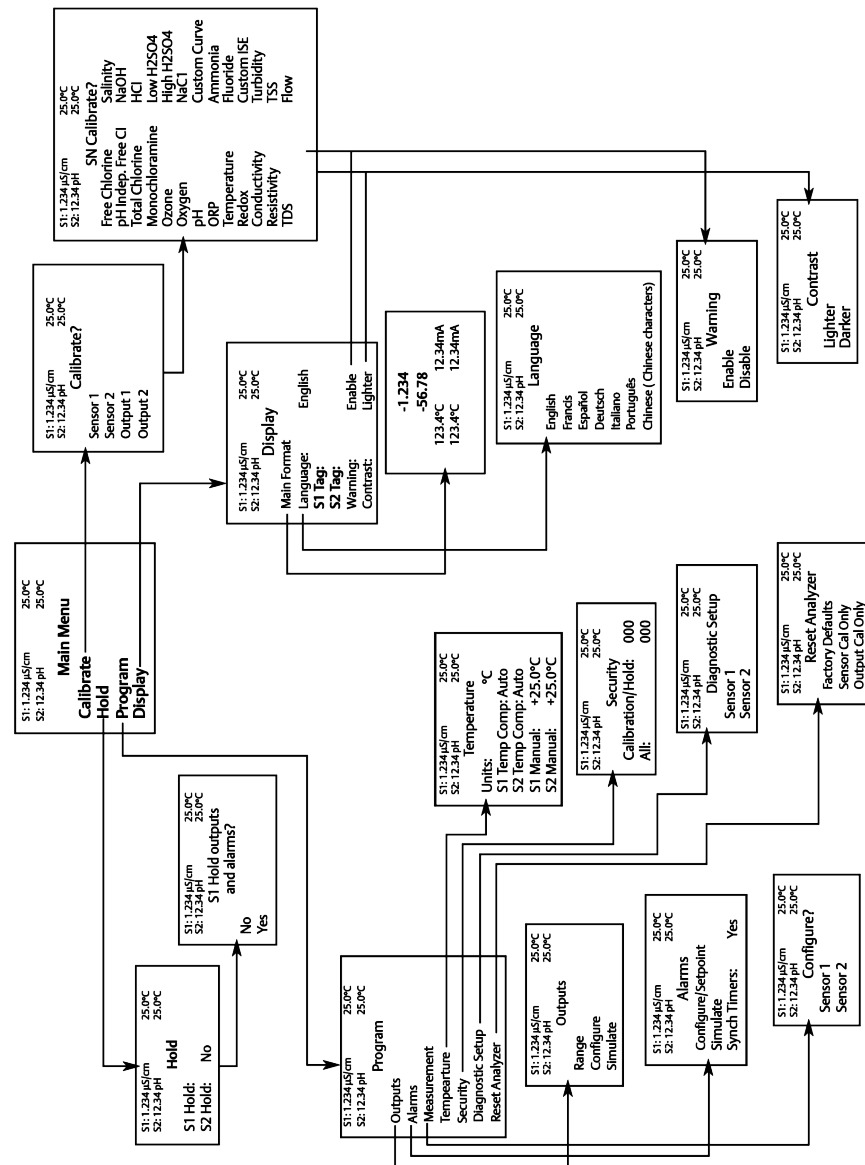

- To return the transmitter to the factory default settings, go to **Program** → **Reset**. Call the Emerson Customer Support Center at +1-800-999-9307 if you need further support.

5 Programming the transmitter

5.1 General programming information

Typical programming steps include the following procedures.

- Change the measurement type, measurement units, and temperature units.
- Choose temperature units and manual or automatic temperature compensation mode.
- Configure and assign values to the current outputs.
- Set a security code for two levels of security access.
- Access menu functions using a security code.
- Enable and disable Hold mode for current outputs.
- Choose the frequency of the AC power (needed for optimum noise rejection).
- Reset all factory defaults, calibration data only, or current output settings only.

5.2 Changing start-up settings

To change the measurement type, measurement units, or temperature units you initially entered in Quick Start, select Reset or access the **Program** menus for the sensor.

Table 5-1 displays the choices for specific measurement type and measurement units available for each sensor measurement board.

Table 5-1: Measurements and measurement units

Signal board	Available measurements	Measurement units
pH/oxidation reduction potential (ORP) 22, 32	<ul style="list-style-type: none"> • pH • ORP • Redox • Ammonia • Fluoride 	<ul style="list-style-type: none"> • pH • mV (ORP) • % • ppm • mg/L • ppb • µg/L

Table 5-1: Measurements and measurement units (continued)

Signal board	Available measurements	Measurement units
Contacting conductivity 20, 30	<ul style="list-style-type: none"> • Conductivity • Resistivity • Total dissolved solids (TDS) • Salinity • NaOH (0-12%) • HCl (0-15%) • Low H₂SO₄ • High H₂SO₄ • NaCl (0-20%) • Custom curve 	<ul style="list-style-type: none"> • μS/cm • mS/cm • S/cm • % (concentration)
Toroidal conductivity 21, 31	<ul style="list-style-type: none"> • Conductivity • Resistivity • TDS • Salinity • NaOH (0-12%) • HCl (0-15%) • Low H₂SO₄ • High H₂SO₄ • NaCl (0-20%) • Custom curve 	<ul style="list-style-type: none"> • μS/cm • mS/cm • S/cm • % (concentration)
Chlorine 24, 34	<ul style="list-style-type: none"> • Free chlorine • Total chlorine • Monochloramine • pH-independent free chlorine 	<ul style="list-style-type: none"> • ppm • mg/L
Oxygen 25, 35	<ul style="list-style-type: none"> • Oxygen (ppm) • Trace oxygen (ppb) • Percent oxygen in gas • Salinity 	<ul style="list-style-type: none"> • ppm • mg/L • ppb • μg/L • % saturation • Partial pressure • % oxygen in gas • ppm oxygen in gas
Ozone 26, 36	Ozone	<ul style="list-style-type: none"> • ppm • mg/L • ppb • μg/L

Table 5-1: Measurements and measurement units (continued)

Signal board	Available measurements	Measurement units
Temperature (all)	Temperature	<ul style="list-style-type: none"> • °F • °C

5.3 Choose temperature units and automatic/manual temperature compensation

Most liquid measurements (except oxidation reduction potential [ORP]) require temperature compensation.

The Rosemount 1056 performs temperature compensation automatically by applying internal temperature correction algorithms. You can also switch to manual temperature compensation. If using manual temperature compensation, the temperature you enter bypasses the one detected by the RTD in the sensor. You can use this method if the RTD in the sensor is malfunctioning.

Procedure

1. From the main menu, go to **Program** → **Temperature**.
2. Select automatic or manual temperature compensation
3. Set the manual reference temperature
4. Program temperature units to °F or °C.

See Figure 5-1.

Figure 5-1: Choosing temperature units and manual temperature compensation

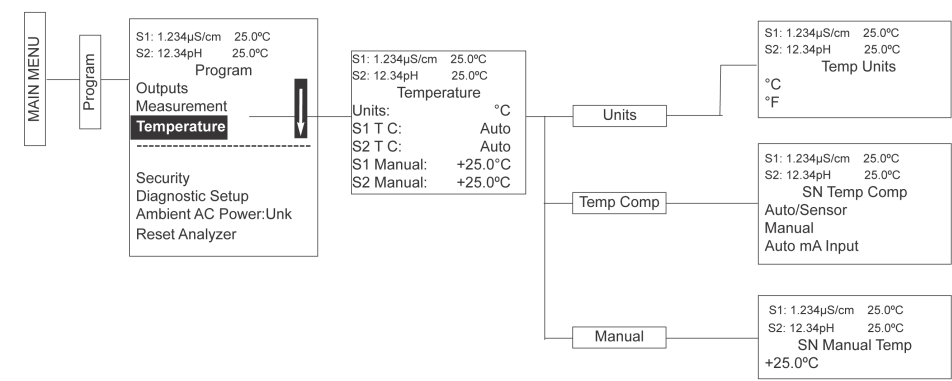

5.4 Configuring and ranging the current outputs

5.4.1 Purpose of configuring and ranging the current outputs

The Rosemount 1056 accepts input from two sensors and has two analog current outputs.

Ranging the outputs means assigning values to the low (0 or 4 mA) and high (20 mA) outputs.

NOTICE

Always configure the outputs before ranging them.

5.4.2 Definitions of outputs

Current outputs	The transmitter provides a continuous output current (4-20 mA or 0-20 mA) directly proportional to the process variable or temperature. You can set the low or high current outputs to any value.
Assigning outputs	Assign a measurement to Output 1 or Output 2.
Dampen	Output dampening smooths out noisy readings. It also increases the response time of the output. Output dampening does not affect the response time of the display.
Mode	You can make the current output directly proportional to the displayed value (linear mode) or directly proportional to the common logarithm of the displayed value (log mode).

5.4.3 Configure outputs

Under the **Program/Outputs** menu, [Figure 5-2](#) appears to allow configuration of the outputs.

Figure 5-2: Configure Output screen

S1: 1.234 μ S/cm 25.0°C
S2: 12.34pH 25.0°C
OutputM Configure
Assign: S1 Meas
Range: 4-20mA
Scale: Linear
Dampening: 0sec

Fault Mode: Fixed
Fault Value: 21.00mA

The screenshot shows a menu screen with a vertical scroll bar on the right side. The scroll bar has a white arrow pointing downwards, indicating that the 'OutputM Configure' section is currently selected and visible.

Follow the menu screens in [Figure 5-3](#) to configure the outputs.

Figure 5-3: Configure and range the current outputs

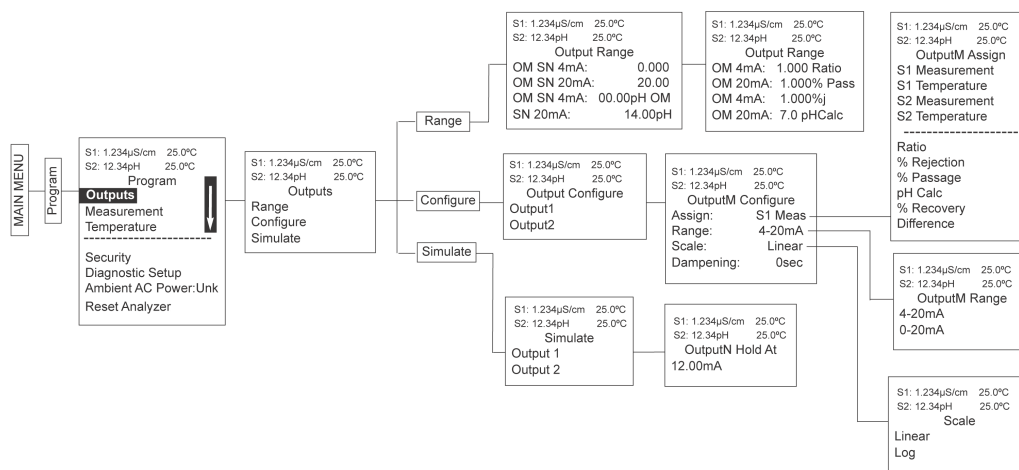

5.4.4 Assign measurements to the low and high current outputs

With these screens, you can assign a measurement, process value, or temperature input to each output

Procedure

1. Go to **Program** → **Output** → **Configure**.

Figure 5-4: Assign Output screen

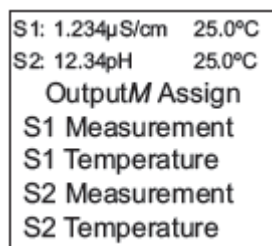

2. Assign measurements to the outputs.

5.4.5 Range current outputs

Go to **Program** → **Output** → **Range**.

Figure 5-5: Output Range screen

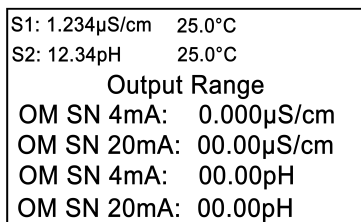

Enter a value for 4 mA and 20 mA (or 0 mA and 20 mA) for each output.

5.5 Set security code

Security codes prevent accidental or unwanted changes to program settings, displays, and calibration.

The Rosemount 1056 has two levels of security codes to control access and use of the transmitter. The two levels of security are:

- All** This is the supervisory security level. It allows access to all menu functions, including programming, calibration, hold, and display.
- Calibration/Hold** This is the operator or technician level menu. It allows access to only calibration and hold of the current outputs.

Procedure

1. Press **MENU**.
The **Main menu** screen appears.
2. Select **Program**.
3. Select **Security**.
The **Security** screen appears.
4. Enter a three digit security code for each of the desired security levels.
The security code takes effect two minutes after the last key stroke.
5. Record the security codes for future access and communication to operators or technicians as needed.

The display returns to the **Security** menu screen.

Figure 5-6 displays the security code screens.

Figure 5-6: Setting a security code

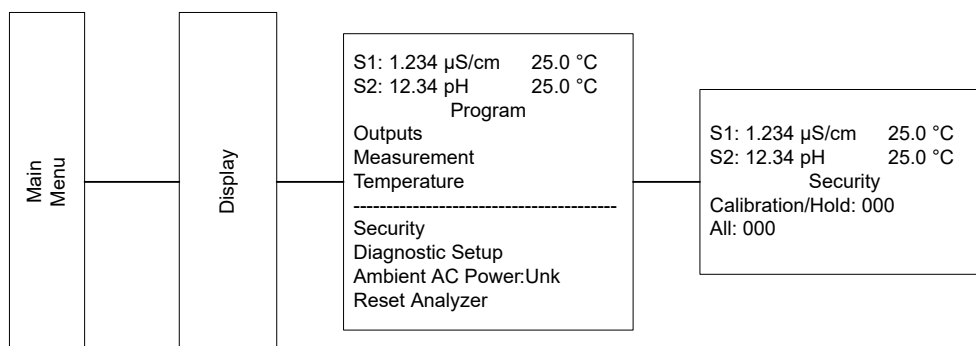

Postrequisites

Press **EXIT** to return to the previous screen. To return to the main display, press **MENU** and then **EXIT**.

5.6 Security access

5.6.1 How the security code works

To access the **Calibration** and **Hold** menus, enter the correct access code for the Calibration/Hold security level. This allows operators or technicians to perform routine maintenance. This does not allow access to the **Program** or **Display** menus.

To access all menu functions, including programming, calibration, hold, and display, enter the correct access code for the All security level.

5.6.2 Use a security code

If someone has programmed a security code, selecting the Calibrate, Hold, Program, or Display top menu items causes the **Security Code** screen to appear.

Figure 5-7: Security Code screen

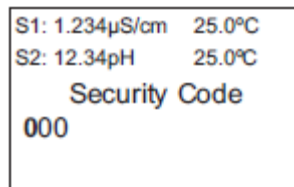

Procedure

Enter the three-digit security code for the appropriate security level.

If the entry is correct, the appropriate menu screen appears. If the entry is incorrect, the **Invalid Code** screen appears. The **Security Code** screen reappears after two seconds.

5.7 Using hold

5.7.1 Purpose of hold

The transmitter output is always proportional to measured value. To prevent improper operation of systems or pumps that are controlled directly by the current output, place the transmitter on hold before removing the sensor for calibration and maintenance.

Be sure to remove the transmitter from hold once you have finished calibrating the sensor. During hold, both outputs remain at the last value.

NOTICE

Once on hold, all current outputs remain on hold indefinitely.

5.7.2 Put outputs on hold

Figure 5-8: Hold menu tree

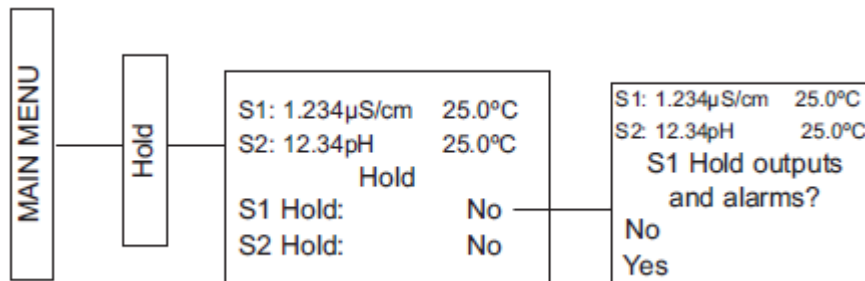

Procedure

1. Press **MENU**.
The **Main Menu** screen appears.
2. Select Hold.
The **Hold Outputs and Alarms?** screen appears.
3. Select Yes to place the transmitter on hold. Select No to take the transmitter out of hold.

NOTICE

There are no alarm relays with this configuration. Current outputs are included with all configurations.

The **Hold** screen appears.

NOTICE

Hold will remain on indefinitely until someone disables it.

5.8 Resetting factory default settings

5.8.1 Purpose of resetting factory default settings

Resetting factory default settings also clears all fault messages and returns the display to the first **Quick Start** screen.

The Rosemount 1056 offers three options for resetting factory defaults:

- Reset all settings to factory defaults.
- Reset sensor calibration data only.
- Reset analog output settings only.

5.8.2 Reset factory default settings

Procedure

To reset factory defaults, reset calibration data only, or reset analog outputs only, follow Figure 5-9.

Figure 5-9: Resetting factory default settings menu tree

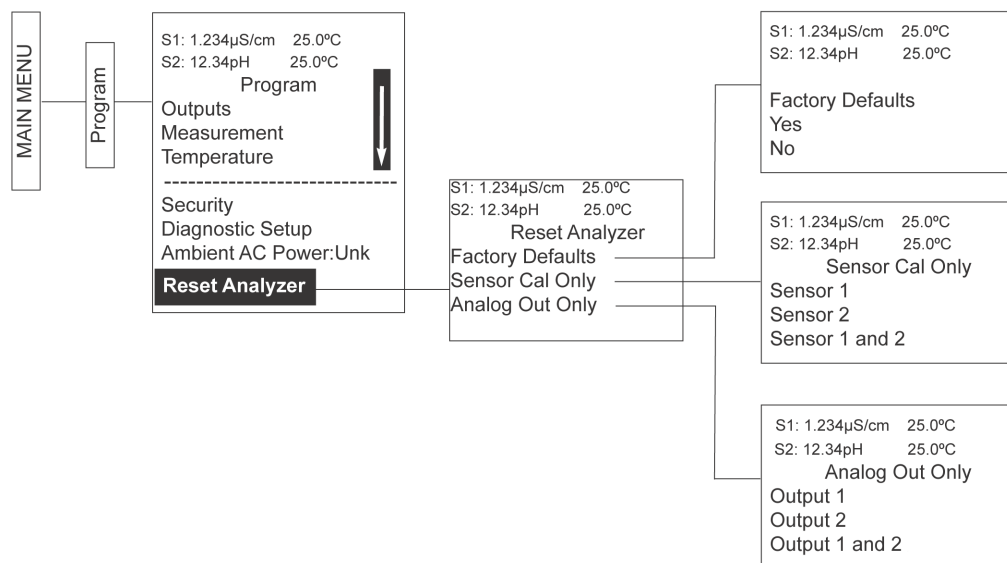

5.9 Program alarm relays

The Rosemount 1056 24 Vdc (02 order code) and the AC switching power supply (03 order code) provide four alarm relays for process measurements or temperature. You can configure each alarm as a fault alarm instead of a process alarm. You can also program each relay independently and/or as an interval timer.

Section	Default	Description
Enter setpoints	100.0 µS/cm	Enter alarm trigger value.
Assign measurement	S1 Measure	Select alarm assignment.
Set relay logic	High	Program relay to activate at high or low reading.
Program the deadband	0.00 µS/cm	Program the change in process value after the relay deactivates.
Program USP safety	0% ↓	Program percentage of the limit to activate the alarm.
Set normal state	Open	Program relay default condition as open or closed for failsafe operation.
Set interval time	24.0 hours	Time in hours between relay activations.
Set relay on-time	10 minutes	Enter the time in seconds that the relay is activated.

Section	Default	Description
Set recovery time	60 seconds	Enter time after the relay deactivation for process recovery.
Program Hold while active	S1	Holds current outputs during relay activation.
Select alarms to simulate	N/A	Manually simulate alarms to confirm relay operation.
Synchronize timers	Yes	Control the timing of two or more relay timers set as interval timers.

Procedure

1. Go to **Program** → **Alarms**.
Figure 5-10 appears to allow you to configure the alarm relays.

Figure 5-10: Alarms screen

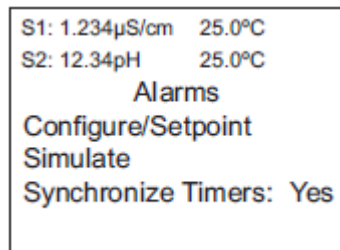

2. Follow the menu screens in Figure 5-3 to configure the outputs.
Figure 5-11 appears to allow you to select a specific alarm relay.

Figure 5-11: Configure/Setpoint screen

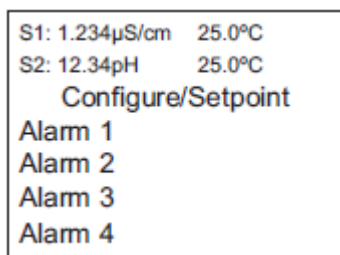

3. Select the desired alarm and press **ENTER**.
[Figure 5-12](#) appears to allow complete programming of each alarm.

Figure 5-12: Alarm Settings screen

S1: 1.234 μ S/cm	25.0°C
S2: 12.34pH	25.0°C
Alarm Settings	
Setpoint:	100.0uS/cm
Assign:	S1 Measure
Logic:	High
Deadband:	0.00uS/cm
USP Safety:	0%↓

Interval time:	24.0 hr
On Time:	120 sec
Recover time:	60 sec
Hold while active:	Sens1

Factory defaults are displayed as they would appear for an installed contacting conductivity board. USP safety appears only if alarm logic is set to USP. Interval time, On Time, Recover time, and Hold while active only appear if the alarm is configured as an interval timer.

5.9.1 Enter setpoints

Go to **Program** → **Alarms**. See [Figure 5-13](#) to configure the alarm relays.

Figure 5-13: Setpoint screen

S1: 1.234 μ S/cm	25.0°C
S2: 12.34pH	25.0°C
Alarm1 S2 Setpoint	
+100.0uS/cm	

Enter the desired value for the process measurement or temperature at which to activate an alarm event.

5.9.2 Assign measurement

See [Figure 5-14](#) (under the **Alarm Settings** menu) to assign alarm relays.

Figure 5-14: Alarm Assign screen

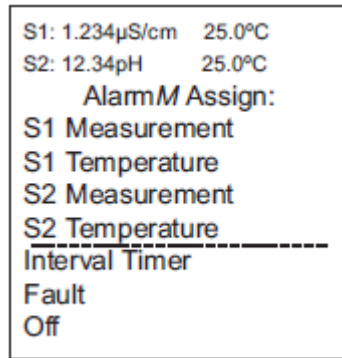

Procedure

Select an alarm assignment.

5.9.3 Set relay logic

See [Figure 5-15](#) (under the **Alarms Settings** menu) to set the alarm logic.

Figure 5-15: Alarm Logic screen

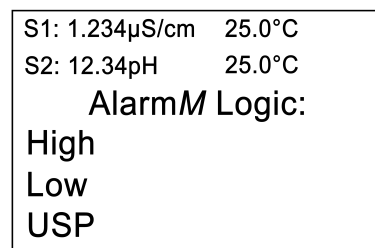

Select the desired relay logic to activate alarms at a high reading or a low reading. USP only appears if a contacting conductivity board is installed.

5.9.4 Program the deadband

See [Figure 5-16](#) (under the **Alarms Settings** menu) to program the deadband as a measurement value.

Enter the change in the process value needed after the relay deactivates to return to normal (thereby preventing repeated alarm activation).

Figure 5-16: Deadband screen

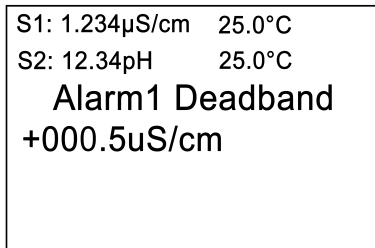

5.9.5 Set normal state

You can define a failsafe condition in the software by programming the alarm default state to normally open or normally closed upon power up. To display this alarm configuration item:

Procedure

1. Hold down the **EXIT** key for six seconds while in the main display mode to enter the **Expert** menus.
The screen prompt `Enable Expert Menu` appears.
2. Select Yes.
3. Under the **Alarm Settings** menu, select Normal State.

Figure 5-17: Normal State screen

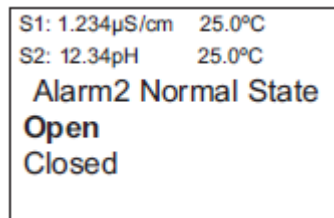

4. Select the alarm condition that you prefer each time the transmitter powers up.

5.9.6 Set interval time

See [Figure 5-18](#) (under the **Alarms Settings** menu) to set the interval time.

Figure 5-18: Interval Time screen

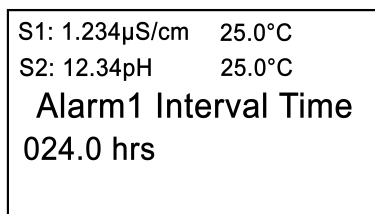

Enter the fixed time in hours between relay activations.

5.9.7 Set relay on-time

See [Figure 5-19](#) (under the **Alarm Settings** menu) to set the relay on-time.

Figure 5-19: On-Time screen

S1: 1.234 μ S/cm	25.0°C
S2: 12.34pH	25.0°C
Alarm1 On-Time	
00.00sec	

Enter the time in seconds that you want the relay to be activated for.

5.9.8 Set recovery time

See [Figure 5-20](#) (under the **Alarms Settings** menu) to set the relay recovery time.

Figure 5-20: Recovery screen

S1: 1.234 μ S/cm	25.0°C
S2: 12.34pH	25.0°C
Alarm1 Recovery	
060sec	

Enter time for process recovery after the relay deactivation.

5.9.9 Program Hold while active

See [Figure 5-21](#) (under the **Alarms Settings** menu) to program the feature that holds the current outputs while alarms are active.

Figure 5-21: Hold while active screen

S1: 1.234 μ S/cm	25.0°C
S2: 12.34pH	25.0°C
Alarm1 Hold while active	
Sensor 1	
Sensor 2	
Both	
None	

Select whether or not to hold the current outputs for Sensor 1, Sensor 2, or both sensors while the relay is activated.

5.9.10 Select alarms to simulate

You can manually set alarm relays to check devices, such as valves or pumps.

See [Figure 5-22](#) (under the **Alarms Settings** menu) to set manual forced activation of the alarm relays. Select the desired alarm condition to simulate.

Figure 5-22: Simulate Alarm screen

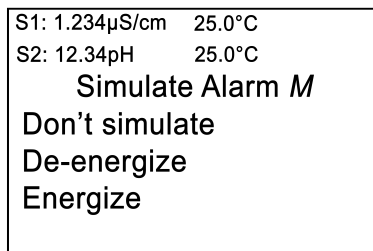

5.9.11 Synchronize timers

See [Figure 5-23](#) (under the **Alarms Settings** menu) to synchronize alarms that are set to interval timers.

Figure 5-23: Synchronize Timers screen

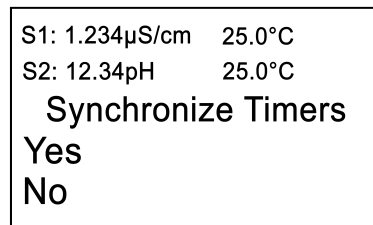

Select Yes or No to synchronize two or more timers.

6 Programming measurements

6.1 Introduction to programming measurements

The Rosemount 1056 automatically recognizes each installed measurement board upon first power-up and each time the transmitter is turned on.

Completing **Quick Start** screens upon first power-up enables measurements, but you may have to take additional steps to program the transmitter for the desired measurement application. This section covers the following programming and configuration functions:

1. Select measurement type or sensor type.
2. Identify the preamp location ([Program pH measurement](#)).
3. Enable manual temperature correction and enter a reference temperature.
4. Enable sample temperature correction and enter temperature correction slope.
5. Define measurement display resolution (pH and amperometric).
6. Define measurement display units.
7. Adjust the input filter to control display and output reading variability or noise.
8. Select a measurement range ([Program contacting conductivity measurement](#) and [Program toroidal conductivity measurement](#)).
9. Enter a cell constant for a contacting or toroidal sensor ([Program contacting conductivity measurement](#) and [Program toroidal conductivity measurement](#)).
10. Enter a temperature element/RTD offset or temperature slope ([Program contacting conductivity measurement](#) and [Program toroidal conductivity measurement](#)).
11. Create an application-specific concentration curve.
12. Enable automatic pH correction for free chlorine measurement ([Program chlorine measurement](#)).

To fully configure the transmitter for each installed measurement board, you may use the following:

1. Reset Analyzer function to reset factory defaults and configure the measurement board to the desired measurement. Follow the **Reset Analyzer** menu to reconfigure the transmitter to display new measurements or measurement units.
2. Program menus to adjust any of the programmable configuration items.

6.2 Program pH measurement

[Figure 6-1](#) is a detailed flow diagram for pH programming to guide you through all basic programming and configuration functions.

Figure 6-1: Flow diagram for pH and oxidation reduction potential (ORP) programming

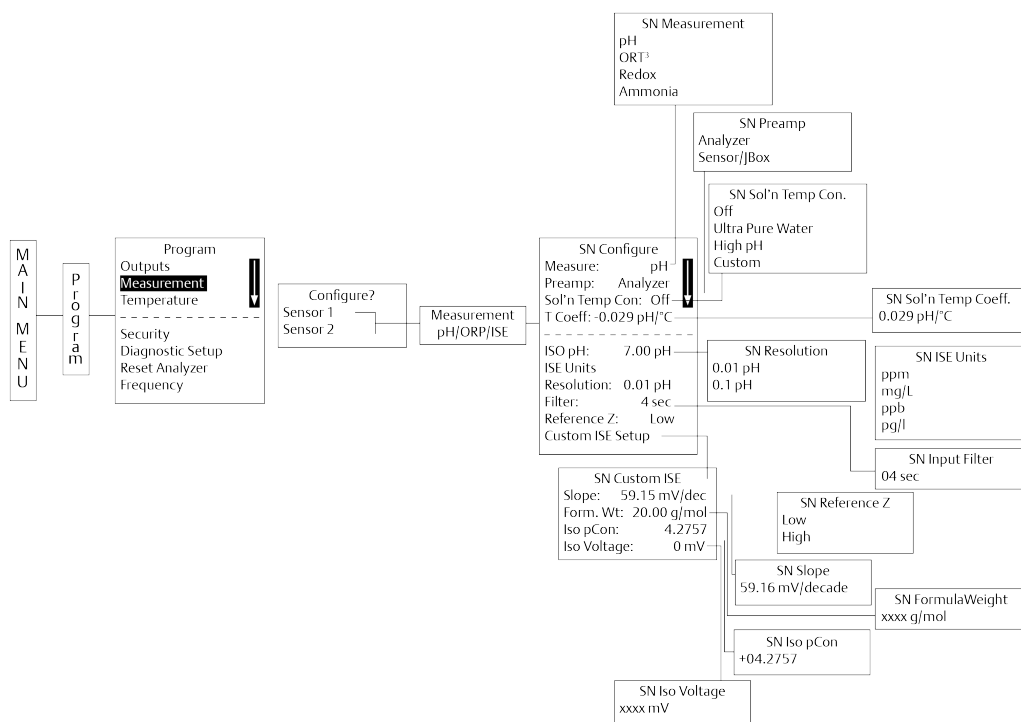

To configure the pH measurement board:

1. Press **MENU**.
2. Go to **Program** → **Measurement**.
3. Select Sensor 1 or Sensor 2 corresponding to pH. Press **ENTER**.

Figure 6-2 appears; factory default settings are shown.

Figure 6-2: Configure pH screen

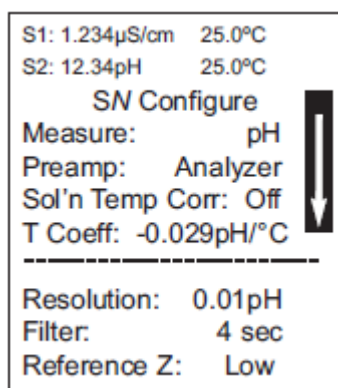

To change any setting, scroll to the desired item and press **ENTER**.

6.2.1 Select measurement type

See [Figure 6-3](#) to select the measurement type.

Figure 6-3: Measurement screen

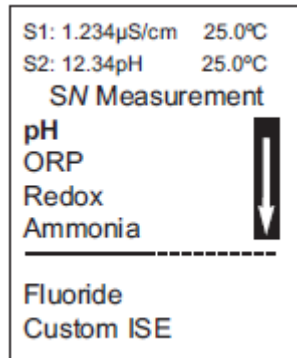

The default value (pH) is displayed in bold type. Refer to [Figure 6-1](#) to select a measurement type.

6.2.2 Select pH preamplifier location

See [Figure 6-4](#) to select the preamplifier (preamp) location.

Figure 6-4: Preamp screen

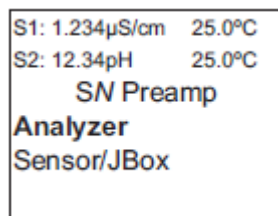

The default value (Analyzer) is displayed in bold type. Refer to [Figure 6-1](#) to select a preamp location.

6.2.3 Select solution temperature correction

See [Figure 6-5](#) to select the solution temperature correction algorithm.

Figure 6-5: Solution Temperature Correction screen

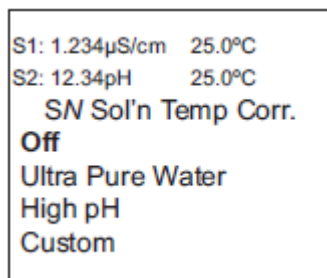

The default value (Off) is displayed in bold type. Refer to [Figure 6-1](#) to select a solution temperature correction algorithm.

6.2.4 Enter custom solution temperature coefficient

See [Figure 6-6](#) to enter a custom solution temperature coefficient.

Figure 6-6: Custom Solution Temperature Coefficient screen

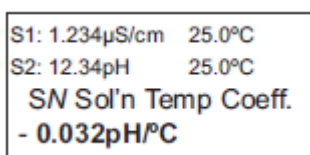

The default value (-0.032 pH/°C) is displayed in bold type. Refer to [Figure 6-1](#) to enter a custom coefficient.

6.2.5 Select display resolution

See [Figure 6-7](#) to select a display resolution.

Figure 6-7: Resolution screen

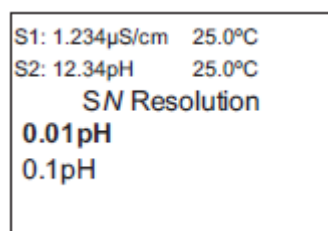

The default value (0.01 pH) is displayed in bold type. Refer to [Figure 6-1](#) to select a resolution.

6.2.6 Enter input filter value

See [Figure 6-8](#) to enter the input filter value in seconds.

Figure 6-8: Input Filter screen

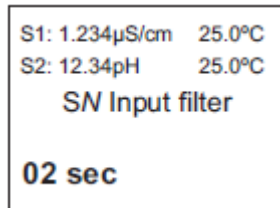

The default value (02 seconds) is displayed in bold type. Refer to [Figure 6-15](#) to enter the input filter value.

6.2.7 Select reference impedance

See [Figure 6-9](#) to select the reference impedance.

Figure 6-9: Reference Z screen

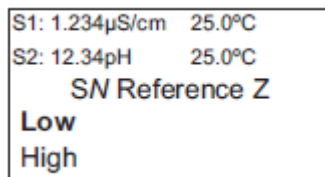

The default value (Low) is displayed in bold type. Refer to [Figure 6-1](#) to select the reference impedance.

6.3 Program oxidation reduction potential (ORP) measurement

[Figure 6-1](#) displays a detailed flow diagram for ORP programming to guide you through all basic programming and configuration functions.

To configure the ORP board:

1. Press **MENU**.
2. Go to **Program** → **Measurement**.
3. Select Sensor 1 or Sensor 2 corresponding to ORP. Press **ENTER**.

[Figure 6-10](#) appears; factory settings are shown.

Figure 6-10: Configure ORP screen

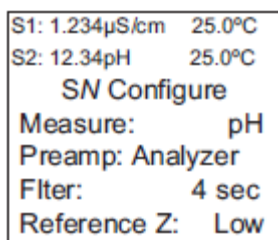

To change any setting, scroll to it and press **ENTER**.

6.3.1 Select measurement type

Figure 6-11 displays the screen from which you can select the measurement type.

Figure 6-11: Measurement Screen

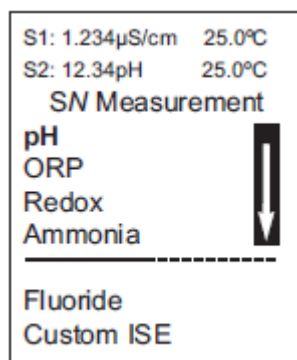

The default value is displayed in bold type. Refer to Figure 6-1 to select the measurement type.

6.3.2 Select preamp location

Figure 6-12 displays the screen from which you can select the preamp location.

Figure 6-12: Preamp Screen

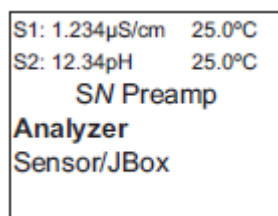

The default value is displayed in bold type. Refer to Figure 6-1 to select the preamp location.

6.3.3 Enter input filter value

Figure 6-13 displays the screen on which you can enter the input filter value.

Figure 6-13: Input Filter Screen

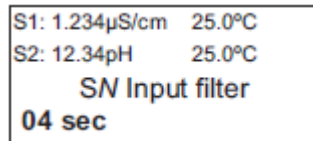

S1: 1.234µS/cm 25.0°C
S2: 12.34pH 25.0°C
SN Input filter
04 sec

The default value is displayed in bold type. Refer to Figure 6-1 to enter the input filter value.

6.3.4 Select reference impedance

Figure 6-14 displays the screen from which you can select the reference impedance.

Figure 6-14: Reference Z Screen

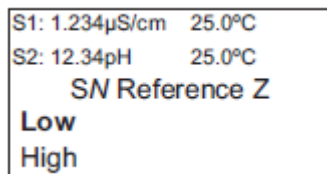

S1: 1.234µS/cm 25.0°C
S2: 12.34pH 25.0°C
SN Reference Z
Low
High

The default value is displayed in bold type. Refer to Figure 6-1 to select the reference impedance.

6.4 Program contacting conductivity measurement

Figure 6-15 guides you through how to configure transmitter to measure contacting conductivity.

Figure 6-15: Contacting Conductivity Flow Diagram

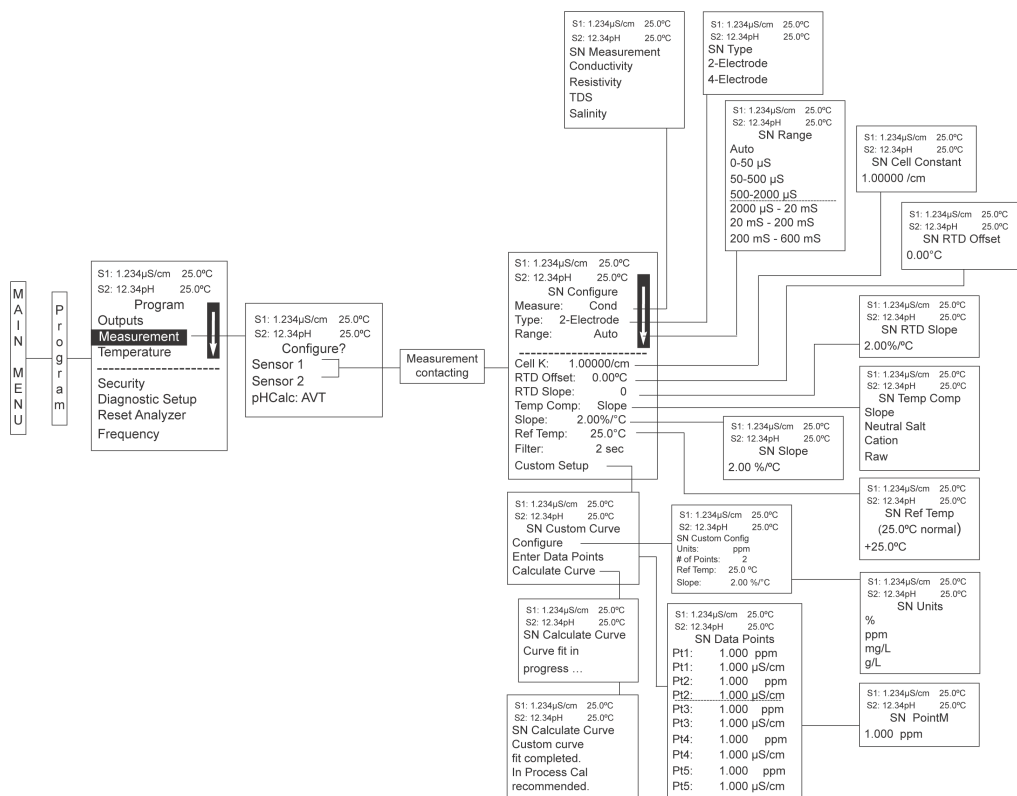

To configure the contacting conductivity measurement board:

Procedure

1. Press **MENU**.
2. Scroll down to Program. Press **ENTER**.

3. Select Sensor 1 or Sensor 2 corresponding to contacting conductivity. Press **ENTER**. [Figure 6-16](#) appears; factory default settings are shown.

Figure 6-16: Configure Conductivity Screen

```
S1: 1.234µS/cm  25.0°C
S2: 12.34pH    25.0°C
SN Configure
Type:  2-Electrode
Measure:  Cond
Range:  Auto
-----
Cell K:  1.00000/cm
RTD Offset:  0.00°C
RTD Slope:   0
Temp Comp:  Slope
Slope:      2.00%/°C
Ref Temp:   25.0°C
Filter:     2 sec
Custom Setup
```

4. To change any settings, scroll to the desired item and press **ENTER**.

6.4.1 Select sensor type

[Figure 6-17](#) displays the screen from which you can select the sensor type.

Figure 6-17: Sensor Type Screen

```
S1: 1.234µS/cm  25.0°C
S2: 12.34pH    25.0°C
SN Type
2-Electrode
4-Electrode
```

The default value is displayed in bold type. Refer to [Figure 6-15](#) to select the sensor type.

6.4.2 Select measurement type

Figure 6-18 displays the screen from which you can select the measurement type.

Figure 6-18: Measurement Screen

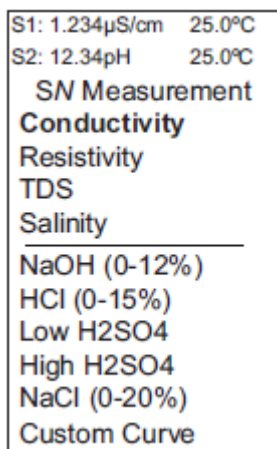

The default value is displayed in bold type. Refer to [Figure 6-15](#) to select a measurement type.

6.4.3 Select range

Figure 6-19 displays the screen from which you can select the sensor range.

Figure 6-19: Range Screen

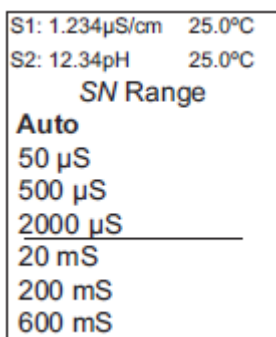

The default value is displayed in bold type.

Note

Ranges are shown as conductance, not conductivity.

Refer to [Figure 6-15](#) to select a range.

6.4.4 Enter cell constant

Figure 6-20 displays the screen on which you can enter the cell constant. The cell constant is on the sensor tag.

Figure 6-20: Cell Constant Screen

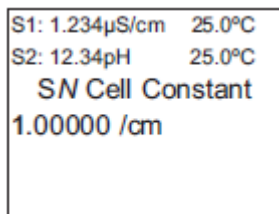

The default value is displayed in bold type. Refer to Figure 6-15 to enter the cell constant.

6.4.5 Resistance temperature detector (RTD) offset

Figure 6-21 displays the screen from which you can enter the RTD offset for a contacting conductivity sensor.

Figure 6-21: RTD Offset Screen

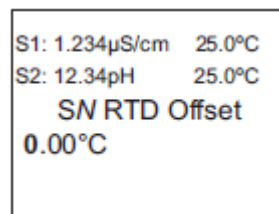

The default value is displayed in bold type. Refer to Figure 6-15 to set the RTD offset.

6.4.6 Resistance temperature detector (RTD) slope

Figure 6-22 displays the screen from which you can enter the RTD slope.

Figure 6-22: RTD Slope Screen

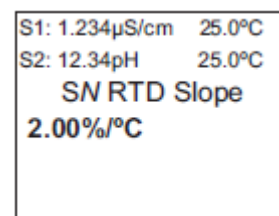

The default value is displayed in bold type. Refer to Figure 6-15 to enter the RTD slope.

6.4.7 Enter temperature compensation

Figure 6-23 displays the screen from which you can select the temperature compensation.

Figure 6-23: Temperature Compensation Screen



S1: 1.234 μ S/cm 25.0 $^{\circ}$ C
S2: 12.34pH 25.0 $^{\circ}$ C
SN Temp Comp
Slope
Neutral Salt
Cation
Raw

The default value is displayed in bold type. Refer to Figure 6-15 to select a temperature compensation.

6.4.8 Enter slope

Figure 6-24 displays the screen on which you can enter the slope.

Figure 6-24: Slope Screen

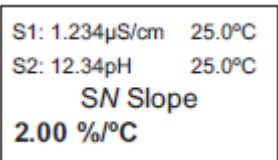

S1: 1.234 μ S/cm 25.0 $^{\circ}$ C
S2: 12.34pH 25.0 $^{\circ}$ C
SN Slope
2.00 %/ $^{\circ}$ C

The default value is displayed in bold type. Refer to Figure 6-15 to enter the slope.

6.4.9 Enter reference temperature

Figure 6-25 displays the screen on which you can enter the reference temperature manually.

Figure 6-25: Reference Temperature Screen

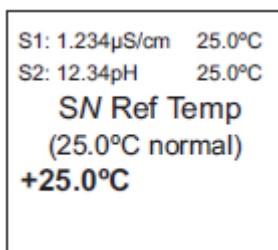

S1: 1.234 μ S/cm 25.0 $^{\circ}$ C
S2: 12.34pH 25.0 $^{\circ}$ C
SN Ref Temp
(25.0 $^{\circ}$ C normal)
+25.0 $^{\circ}$ C

The default value is displayed in bold type. Refer to Figure 6-15 to complete this function.

6.4.10 Enter input filter value

See [Figure 6-26](#) to enter the input filter value in seconds.

Figure 6-26: Input Filter screen

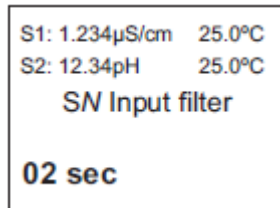

The default value (02 seconds) is displayed in bold type. Refer to [Figure 6-15](#) to enter the input filter value.

6.4.11 Create custom curve

[Figure 6-27](#) displays the screen from which you can create a custom curve for converting conductivity into concentration.

Figure 6-27: Custom Curve Screen

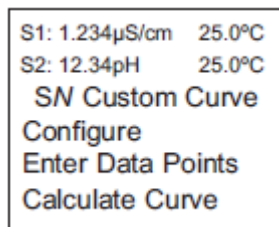

Refer to [Figure 6-15](#) to create a custom curve.

Procedure

Enter the custom curve data. Press **ENTER**.

The display confirms the determination of a custom curve fit to the entered data by displaying [Figure 6-28](#).

Figure 6-28: Calculate Curve Screen

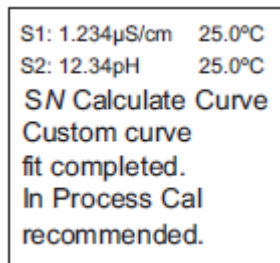

If the custom curve fit is not completed or is unsuccessful, [Figure 6-29](#) appears. The transmitter returns to the screen shown in [Figure 6-27](#).

Figure 6-29: Calculate Curve Failure Screen

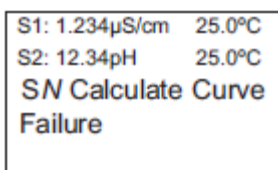

S1: 1.234 μ S/cm 25.0°C
S2: 12.34pH 25.0°C
**SN Calculate Curve
Failure**

6.4.12 Enter calibration factor

Figure 6-30 displays the screen on which you can enter a calibration factor.

Figure 6-30: Calibration Factor Screen

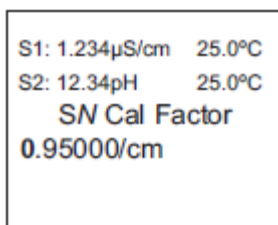

S1: 1.234 μ S/cm 25.0°C
S2: 12.34pH 25.0°C
**SN Cal Factor
0.95000/cm**

The default value is displayed in bold type.

Procedure

If you selected 4-electrode for the sensor type in the **Quick Start** menus, enter a cell constant and a calibration factor using the transmitter keypad.

The cell constant is needed to convert measured conductance to conductivity, as displayed on the transmitter screen. The calibration factor entry is needed to increase the accuracy of the live conductivity readings, especially at low conductivity readings below 20 μ S/cm. Both the cell constant and the calibration factor are printed on the tag attached to the four-electrode sensor cable.

6.5 Program toroidal conductivity measurement

Configure the transmitter for conductivity measurements using inductive/toroidal sensors.

Figure 6-31: Toroidal Conductivity Flow Diagram

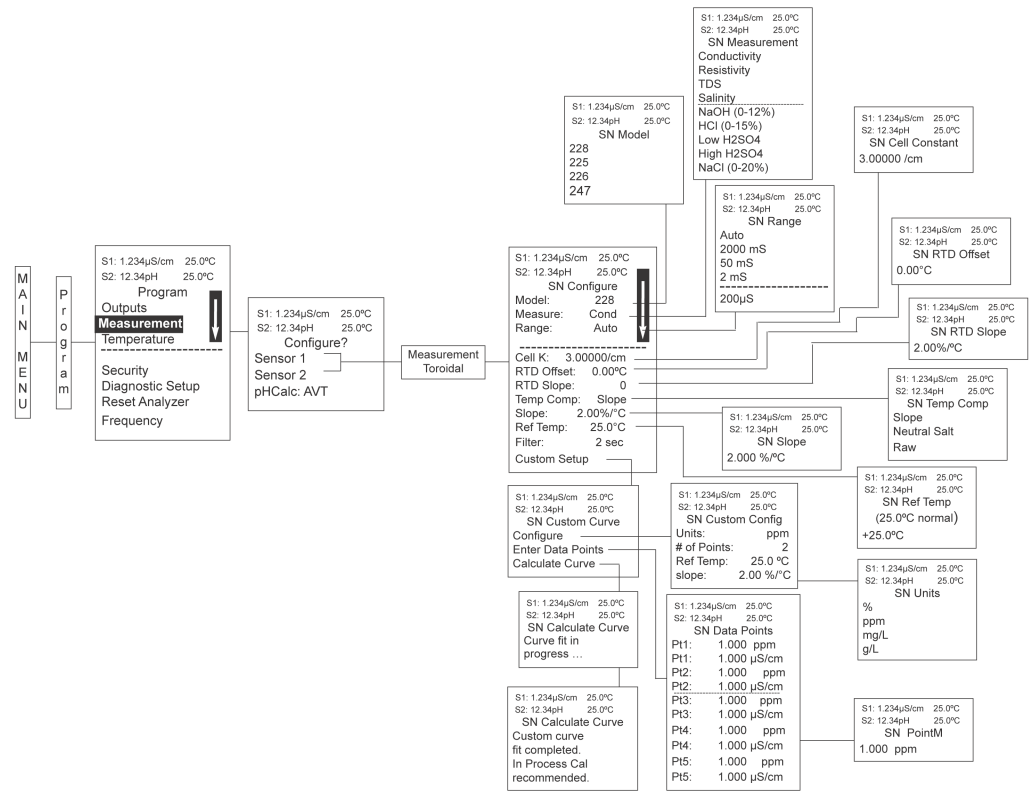

Figure 6-31 is a detailed flow diagram for programming toroidal conductivity.

To configure the toroidal conductivity measurement board:

Procedure

1. Press **MENU**.
2. Scroll down to Program. Press **ENTER**.
3. Scroll down to Measurement. Press **ENTER**.

4. Select Sensor 1 or Sensor 2 corresponding to toroidal conductivity. Press **ENTER**. [Figure 6-32](#) appears; factory default settings are shown.

Figure 6-32: Configure Toroidal Conductivity Sensor Screen

```
S1: 1.234µS/cm  25.0°C
S2: 12.34pH     25.0°C
  SN Configure
Model:         228
Measure:      Cond
Range:        Auto
-----
Cell K: 3.00000/cm
RTD Offset: 0.00°C
RTD Slope:    0
Temp Comp: Slope
Slope:       2.00%/°C
Ref Temp:    25.0°C
Filter:      2 sec
Custom Setup
```

5. To change any setting, scroll to the desired item and press **ENTER**.

6.5.1 Select sensor model

[Figure 6-33](#) displays the screen from which you can select the sensor model.

Figure 6-33: Sensor Model screen

```
S1: 1.234µS/cm  25.0°C
S2: 12.34pH     25.0°C
  SN Model
228
225
226
242
-----
Other
```

The default value is displayed in bold type. Refer to [Figure 6-31](#) to select a sensor model.

6.5.2 Select measurement type

Figure 6-34 displays the screen from which you can select the measurement type.

Figure 6-34: Measurement Type Screen

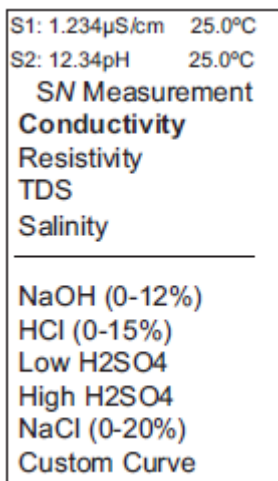

The default value is displayed in bold type. Refer to Figure 6-31 to select the measurement type.

6.5.3 Select sensor range

Figure 6-35 displays the screen from which you can select the sensor range.

Figure 6-35: Range Screen

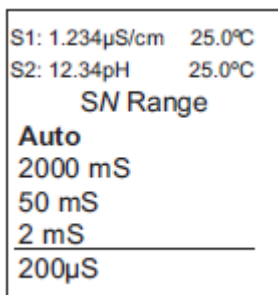

The default value is displayed in bold type.

Note

Ranges are shown as conductance, not conductivity.

Refer to Figure 6-31 to select a range.

6.5.4 Enter a cell constant

Figure 6-36 displays the screen from which you can enter the cell constant.

Figure 6-36: Cell Constant Screen

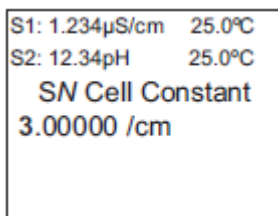

```
S1: 1.234µS/cm 25.0°C
S2: 12.34pH 25.0°C
SN Cell Constant
3.00000 /cm
```

The default value is displayed in bold type. Refer to [Figure 6-31](#) to enter the cell constant.

6.5.5 Select temperature compensation

Figure 6-37 displays the screen from which you can select the temperature compensation.

Figure 6-37: Temperature Compensation Screen

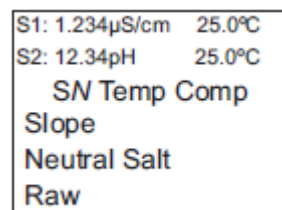

```
S1: 1.234µS/cm 25.0°C
S2: 12.34pH 25.0°C
SN Temp Comp
Slope
Neutral Salt
Raw
```

Refer to [Figure 6-31](#) to select the temperature compensation.

6.5.6 Enter slope

Figure 6-38 displays the screen on which you can enter the conductivity/temperature slope.

Figure 6-38: Slope Screen

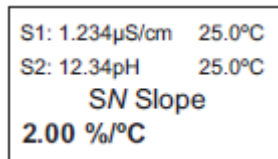

```
S1: 1.234µS/cm 25.0°C
S2: 12.34pH 25.0°C
SN Slope
2.00 %/°C
```

The default value is displayed in bold type. Refer to [Figure 6-31](#) to enter the slope.

6.5.7 Enter the reference temperature

Figure 6-39 displays the screen on which you can manually enter the reference temperature.

Figure 6-39: Reference Temperature Screen

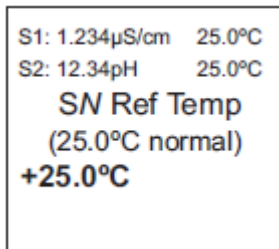

The default value is displayed in bold type. Refer to Figure 6-31 to enter the reference temperature.

6.5.8 Enter input filter value

Figure 6-40 displays the screen on which you can enter the input filter time in seconds.

Figure 6-40: Input Filter Screen

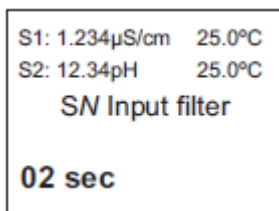

The default value is displayed in bold type. Refer to Figure 6-31 to enter the input filter time.

6.5.9 Create custom curve

Figure 6-41 displays the screen from which you can create a custom curve to convert conductivity to concentration.

Figure 6-41: Custom Curve Screen

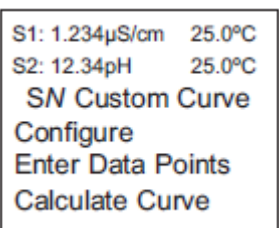

Refer to Figure 6-31 to complete this task.

Procedure

Enter the custom curve data and press **ENTER**.

The display confirms the determination of a custom curve fit to the entered data by displaying [Figure 6-42](#).

Figure 6-42: Calculate Curve Screen

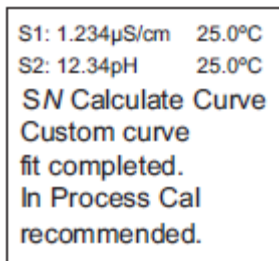

S1: 1.234 μ S/cm 25.0°C
S2: 12.34pH 25.0°C
SN Calculate Curve
Custom curve
fit completed.
In Process Cal
recommended.

If the custom curve fit is not completed or is unsuccessful, [Figure 6-43](#) appears and the transmitter returns to the screen shown in [Figure 6-41](#).

Figure 6-43: Curve Failure Screen

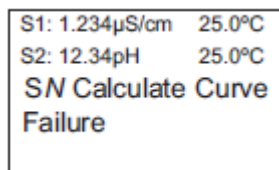

S1: 1.234 μ S/cm 25.0°C
S2: 12.34pH 25.0°C
SN Calculate Curve
Failure

6.6 Program chlorine measurement

With a chlorine measurement board installed, the transmitter can measure any of four variants of chlorine.

- Free chlorine
- Total chlorine
- Monochloramine
- pH-independent free chlorine

6.6.1 Program free chlorine measurement

Configure the Rosemount 1056 transmitter for free chlorine measurement using amperometric chlorine sensors.

Figure 6-44: Chlorine Measurements Flow Diagram

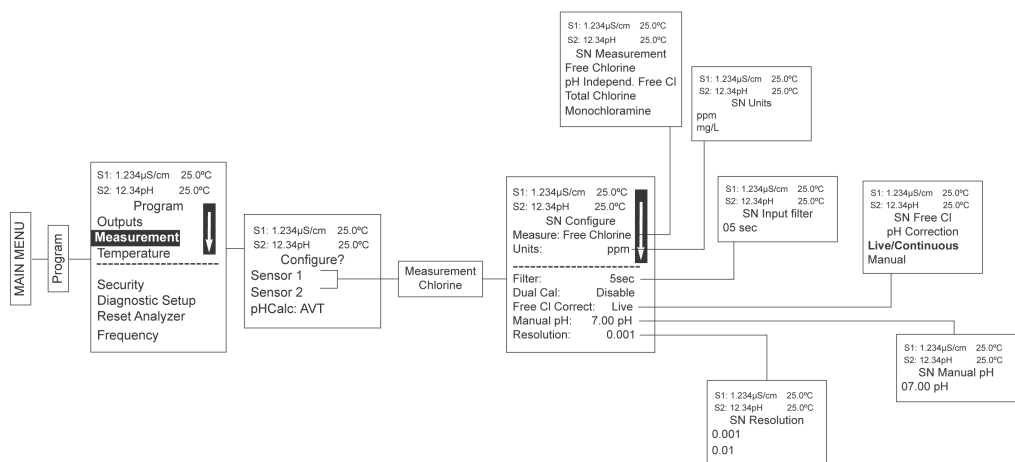

Figure 6-44 is a detailed flow diagram to guide you through all basic programming and configuration functions.

To configure the measurement board for free chlorine:

Procedure

1. Press **MENU**.
2. Scroll down to Program. Press **ENTER**.
3. Scroll down to Measurement. Press **ENTER**.
4. Select Sensor 1 or Sensor 2 corresponding to free chlorine. Press **ENTER**.
Figure 6-45 appears; factory default settings are shown.

Figure 6-45: Configure Free Chlorine Screen

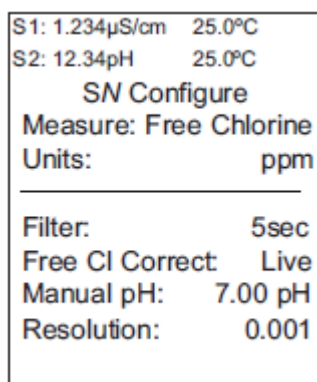

5. To change any setting, scroll to the desired item and press **ENTER**.

Select measurement type

Figure 6-46 displays the screen from which you can select the measurement type.

Figure 6-46: Measurement Screen

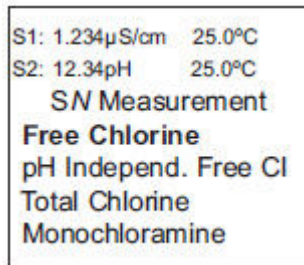

The default value is displayed in bold type.

Procedure

1. Select Free Chlorine.
2. Press **ENTER**.

Select measurement unit

Figure 6-47 displays the screen from which you can select a measurement unit.

Figure 6-47: Units Screen

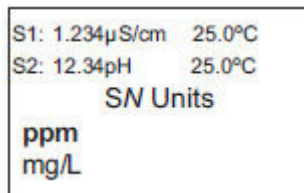

The default value is displayed in bold type.

Procedure

Refer to Figure 6-44 to select a measurement unit.

Enter input filter value

Figure 6-48 displays the screen on which you can enter the input filter value for free chlorine in seconds.

Figure 6-48: Input Filter Screen

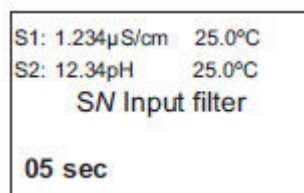

The default value is displayed in bold type.

Procedure

Refer to [Figure 6-44](#) to enter an input filter value.

Select pH correction

[Figure 6-49](#) displays the screen from which you can select live/continuous pH correction or manual pH correction.

Figure 6-49: Free Chlorine pH Correction Screen

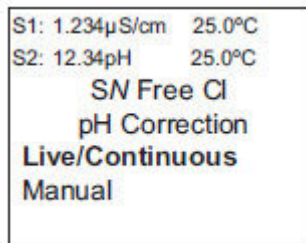

The default value is displayed in bold type.

Procedure

Refer to [Figure 6-44](#) to select the pH correction.

Enter pH correction manually

[Figure 6-50](#) displays the screen on which you can manually enter the pH value of the measured process liquid.

Figure 6-50: Manual pH Screen

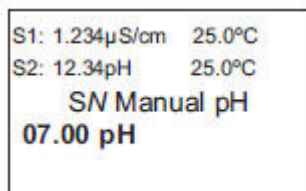

The default value is displayed in bold type.

Procedure

Refer to [Figure 6-44](#) to enter a pH value manually.

Select display resolution

Figure 6-51 displays the screen from which you can select a display resolution.

Figure 6-51: Resolution Screen

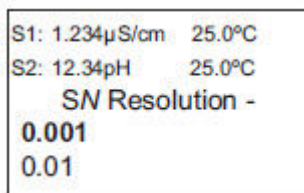

The default value is displayed in bold type.

Procedure

Refer to Figure 6-44 to select a display resolution.

6.6.2 Program total chlorine measurement

Configure the transmitter for total chlorine measurement using amperometric chlorine sensors.

Figure 6-44 is a detailed flow diagram for programming all chlorine measurements.

To configure the chlorine measurement board for total chlorine:

Procedure

1. Press **MENU**.
2. Scroll down to Program. Press **ENTER**.
3. Scroll down to Measurement. Press **ENTER**.
4. Select Sensor 1 or Sensor 2 corresponding to chlorine. Press **ENTER**.
Figure 6-52 will appear; factory default settings are shown.

Figure 6-52: Configure Chlorine Screen

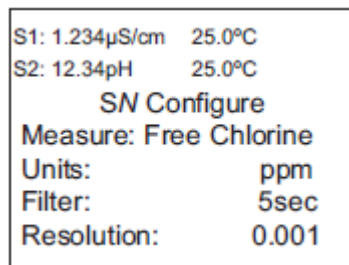

5. To change any setting, scroll to the desired item and press **ENTER**.

Select measurement type

Figure 6-53 displays the screen from which you can select the type of chlorine measurement.

Figure 6-53: Measurement Screen



The default value is displayed in bold type.

Procedure

Refer to Figure 6-44 to select a measurement type.

Select measurement units

Figure 6-54 displays the screen from which you can select measurement units as ppm or mg/L.

Figure 6-54: Units Screen

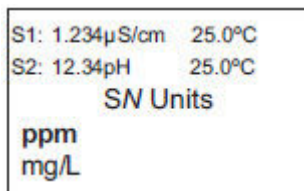

The default value is displayed in bold type.

Procedure

Refer to Figure 6-44 to select measurement units.

Enter input filter value

Figure 6-55 displays the screen on which you can enter the input filter value in seconds.

Figure 6-55: Input Filter Screen

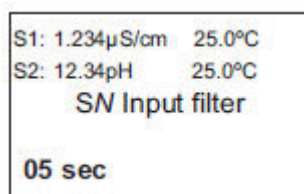

The default value is displayed in bold type.

Procedure

Refer to [Figure 6-44](#) to enter the input filter value.

Select display resolution

[Figure 6-56](#) displays the screen from which you can select the display resolution.

Figure 6-56: Resolution Screen

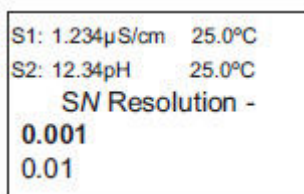

The default value is displayed in bold type.

Procedure

Refer to [Figure 6-44](#) to select the display resolution.

6.6.3

Program monochloramine measurement

Configure the transmitter to measure monochloramine using amperometric chlorine sensors.

To configure the chlorine measurement board for monochloramine:

Procedure

1. Press **MENU**.
2. Scroll down to Program. Press **ENTER**.
3. Scroll down to Measurement. Press **ENTER**.
4. Select Sensor 1 or Sensor 2 corresponding to chlorine. Press **ENTER**.
[Figure 6-57](#) appears; factory default settings are shown.

Figure 6-57: Configure Chlorine Screen

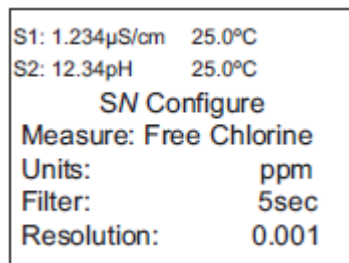

5. To change any settings, scroll to the desired item and press **ENTER**.

Select measurement type

Figure 6-58 displays the screen from which you can select the type of chlorine to measure.

Figure 6-58: Measurement Screen

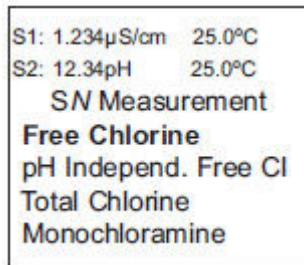

The default value is displayed in bold type.

Procedure

Refer to Figure 6-44 to select the monochloramine measurement type.

Select measurement units

Figure 6-59 displays the screen from where you can select measurement units: ppm or mg/L.

Figure 6-59: Units Screen

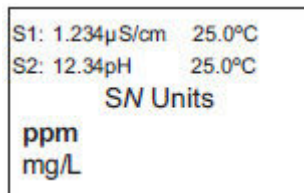

The default value is displayed in bold type.

Procedure

Refer to Figure 6-44 to select measurement units.

Enter input filter value

Figure 6-60 shows the screen on which you can enter the input filter value in seconds.

Figure 6-60: Input Filter Screen

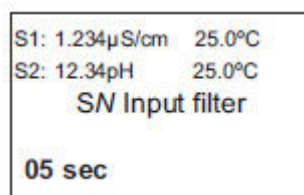

The default value is displayed in bold type.

Procedure

Refer to [Figure 6-44](#) to enter the input filter value.

Select display resolution

[Figure 6-61](#) displays the screen from which you can enter the display resolution.

Figure 6-61: Resolution Screen

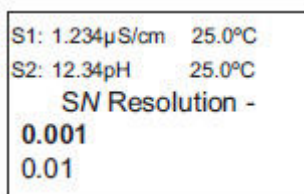

The default value is displayed in bold type.

Procedure

Refer to [Figure 6-44](#) to select the display resolution.

6.6.4 Program pH-independent free chlorine measurement

Configure the transmitter to measure pH-independent free chlorine using amperometric chlorine sensors.

See [Figure 6-44](#) to guide you through configuring the transmitter to measure pH-independent free chlorine.

To configure the chlorine measurement board for pH-independent free chlorine:

Procedure

1. Press **MENU**.
2. Scroll down to Program. Press **ENTER**.
3. Scroll down to Measurement. Press **ENTER**.
4. Select Sensor 1 or Sensor 2 corresponding to chlorine. Press **ENTER**.
[Figure 6-62](#) appears; factory default settings are shown.

Figure 6-62: Configure Chlorine Measurement Screen

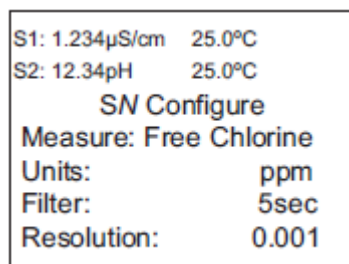

Select the pH-independent free chlorine measurement

Procedure

1. From the **Configure Chlorine** screen, select Measurement.
[Figure 6-63](#) appears. The default value is displayed in bold text.

Figure 6-63: Measurement Screen



2. Select pH Independ. Free Cl.

Select measurement units

Procedure

1. From the **Configure Chlorine** screen, select Units.
[Figure 6-64](#) appears. The default value is displayed in bold type.

Figure 6-64: Units Screen

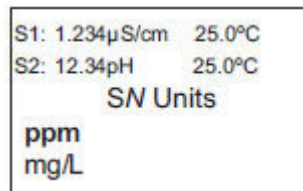

2. Refer to [Figure 6-44](#) to select units.

Enter input filter value

Procedure

1. From the **Configure Chlorine** screen, select Filter.
[Figure 6-65](#) appears. The default value is displayed in bold type.

Figure 6-65: Input Filter Screen

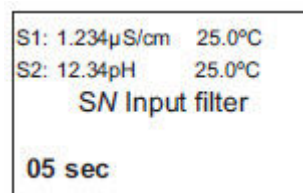

2. Refer to [Figure 6-44](#) to enter the input filter value in seconds.

Select display resolution

Procedure

1. From the **Configure Chlorine** screen, select Resolution. [Figure 6-66](#) appears. The default value is displayed in bold type.

Figure 6-66: Resolution Screen

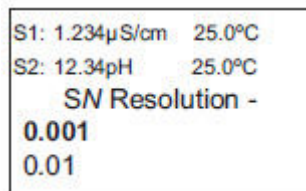

2. Refer to [Figure 6-44](#) to select a display resolution.

6.7 Program oxygen measurement

You can configure the Rosemount 1056 transmitter to measure dissolved and gaseous oxygen using amperometric oxygen sensors.

[Figure 6-67](#) is a detailed diagram for oxygen programming to guide you through all basic programming and configuration functions.

Figure 6-67: Programming Oxygen Measurement

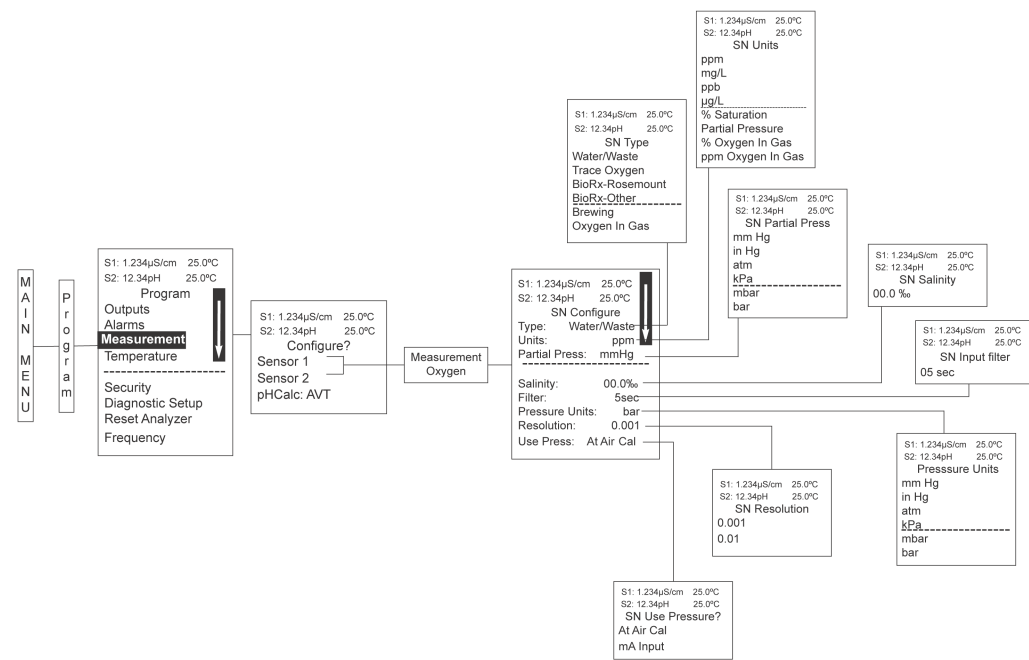

To configure the oxygen measurement board.

Procedure

1. Press **MENU**.
2. Scroll down to Program. Press **ENTER**.
3. Scroll down to Measurement. Press **ENTER**.
4. Select Sensor 1 or Sensor 2 corresponding to oxygen. Press **ENTER**.
[Figure 6-68](#) appears; factory default settings are shown.

Figure 6-68: Configure Oxygen Screen

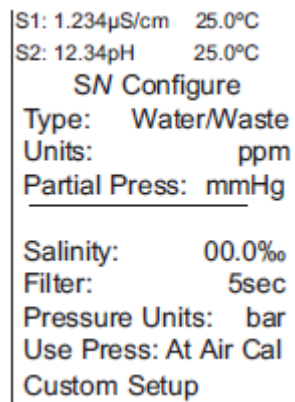

5. To change a setting, scroll to the desired item and press **ENTER**.

6.7.1 Select oxygen measurement application

Procedure

1. From the **Configure Oxygen** screen, select Type.
[Figure 6-69](#) appears.

Figure 6-69: Type Screen

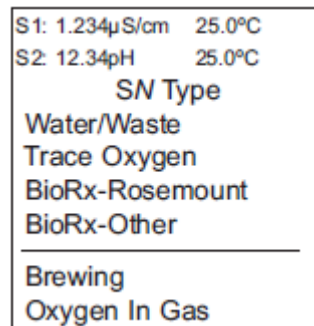

2. Refer to [Figure 6-67](#) to select the application.

6.7.2 Select measurement units

The default value is displayed in **bold type**.

Procedure

1. From the **Configure Oxygen** screen, select Units.
[Figure 6-70](#) appears.

Figure 6-70: Units Screen

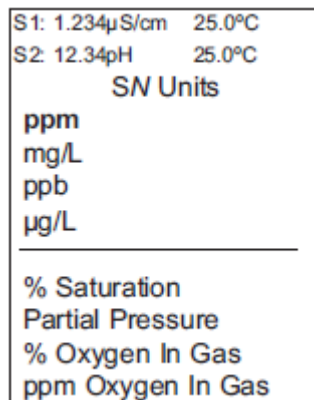

Measurement unit options are:

- ppm
- mg/L
- ppb
- μg/L
- % Saturation
- Partial Pressure
- % Oxygen in Gas
- ppm Oxygen in Gas

2. Refer to [Figure 6-67](#) to select a measurement unit.

6.7.3 Select partial pressure units

If you select Partial Pressure as the measurement unit on the **Units** screen, you need to select the partial pressure measurement units.

Procedure

1. From the **Configure Oxygen** screen, select Units.
The **Units** screen appears.

2. Select Partial Pressure.
[Figure 6-71](#) appears.

Figure 6-71: Partial Pressure Screen

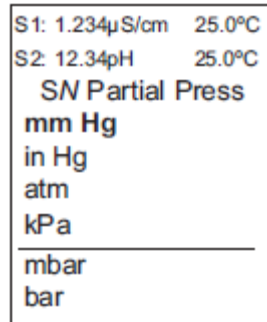

Partial pressure options are:

- mm Hg
- in Hg
- atm (atmospheric)
- kPa
- mbar
- bar

3. Refer to [Figure 6-67](#) to select a partial pressure unit.

6.7.4 Enter salinity

Procedure

1. From the **Configure Oxygen** screen, select Salinity.
[Figure 6-72](#) appears.

Figure 6-72: Salinity Screen

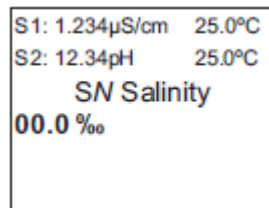

2. Enter the percentage of salinity in the process liquid.
Refer to [Figure 6-67](#).

6.7.5 Enter input filter value

Procedure

1. From the **Configure Oxygen** screen, select Filter.
[Figure 6-73](#) appears.

Figure 6-73: Input Filter Screen

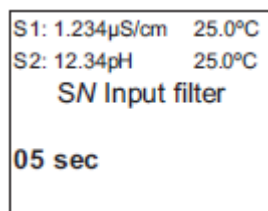

2. Refer to [Figure 6-67](#) to enter the input filter value in seconds.

6.7.6 Select atmospheric pressure units

Select atmospheric pressure units to determine how the transmitter will display atmospheric pressure measured by the pressure transducer on the oxygen measurement board.

Procedure

1. From the **Configure Oxygen** screen, select Pressure Units.
[Figure 6-74](#) appears.

Figure 6-74: Units Screen

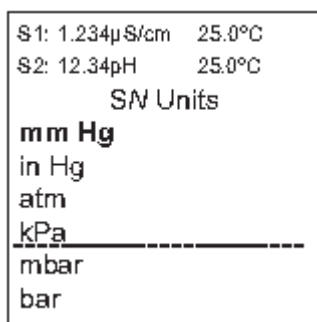

Pressure unit options are:

- mm Hg
- in Hg
- atm (atmospheric)
- kPa
- mbar
- bar

2. Refer to [Figure 6-67](#) to select the atmospheric pressure unit.

6.7.7 Enter display resolution

Procedure

1. From the **Oxygen Configure** screen, select Resolution.
[Figure 6-75](#) appears.

Figure 6-75: Resolution Screen

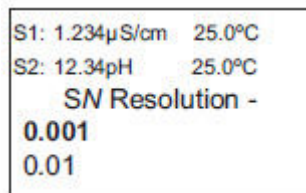

2. Refer to [Figure 6-67](#) to select the display resolution.

6.7.8 Select oxygen atmospheric pressure source

Procedure

1. From the **Oxygen Configure** screen, select Use Press.
[Figure 6-76](#) appears.

Figure 6-76: Use Pressure Screen

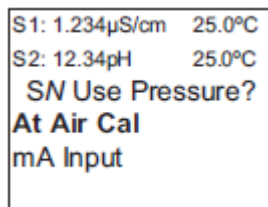

2. Refer to [Figure 6-67](#) to select the atmospheric pressure source.

6.8 Program ozone measurement

You can configure the Rosemount 1056 transmitter to measure ozone using amperometric ozone sensors.

Figure 6-77: Ozone Measurement Flow Diagram

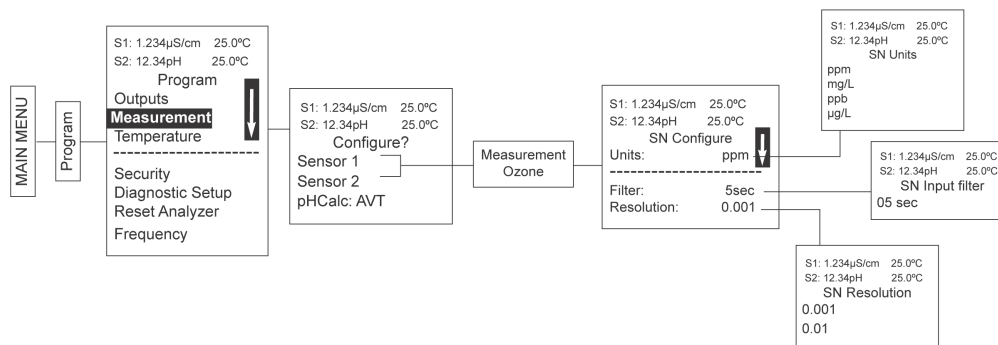

Figure 6-77 is a detailed flow diagram for ozone programming to guide you through all basic programming and configuration functions.

To configure the ozone measurement board:

Procedure

1. Press **MENU**.
2. Scroll down to Program. Press **ENTER**.
3. Scroll down to Measurement. Press **ENTER**.
4. Select Sensor 1 or Sensor 2 corresponding to ozone. Press **ENTER**.
Figure 6-78 appears; factory default settings are shown.

Figure 6-78: Configure Ozone Screen

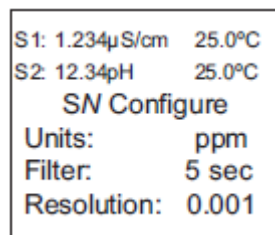

5. To program any displayed function, scroll to the desired item and press **ENTER**.

Note

The transmitter automatically detects ozone measurement boards. You don't need to select a measurement type.

6.8.1 Select measurement units

Procedure

1. From the **Ozone Configure** screen, select Units.
[Figure 6-79](#) appears.

Figure 6-79: Units Screen

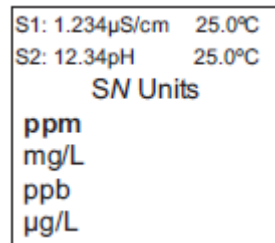

Ozone measurement unit options are:

- ppm
- mg/L
- ppb
- µg/L

2. Refer to [Figure 6-77](#) to select a measurement unit.

6.8.2 Enter input filter value

Procedure

1. From the **Ozone Configure** screen, select Filter.
[Figure 6-80](#) appears.

Figure 6-80: Input Filter Screen

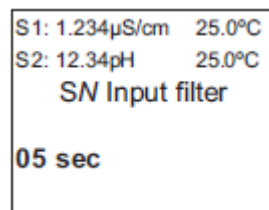

2. Refer to [Figure 6-77](#) to enter the input filter value in seconds.

6.8.3 Select display resolution

Procedure

1. From the **Ozone Configure** screen, select Resolution.
[Figure 6-81](#) appears.

Figure 6-81: Resolution Screen

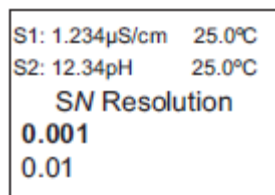

2. Refer to Figure 6-77 to select the display resolution.

6.9 Program turbidity measurement

Configure the Rosemount 1056 to measure turbidity.

Figure 6-82: Turbidity Flow Diagram

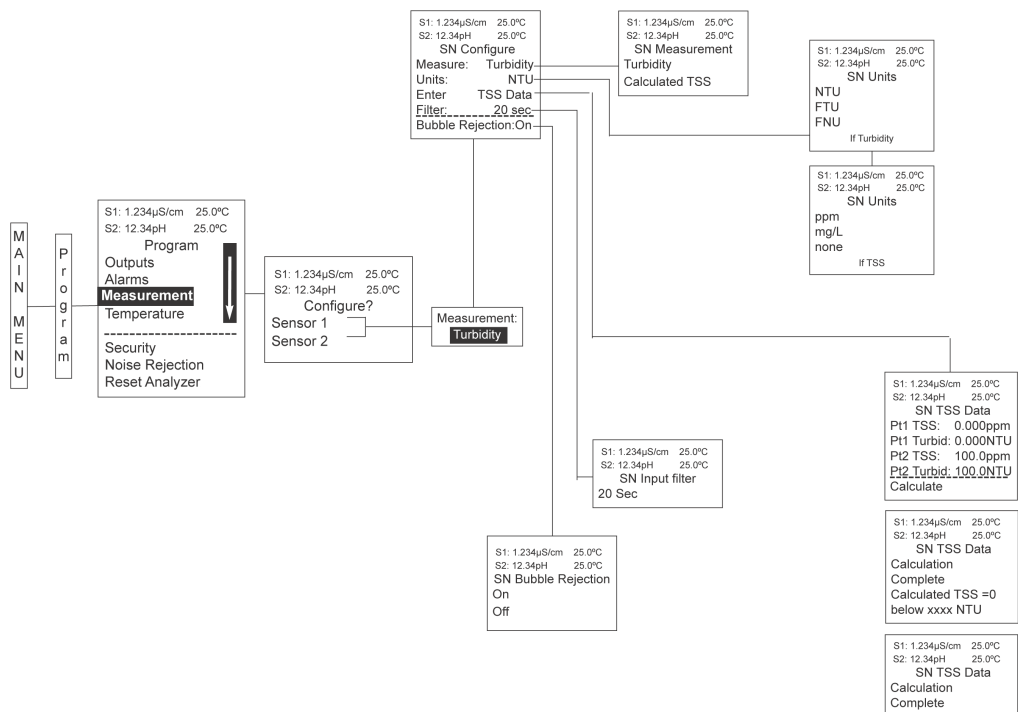

Figure 6-82 is a detailed flow diagram for turbidity programming; use it to guide you through all basic programming and configuration functions.

To configure the turbidity measurement board:

Procedure

1. Press **MENU**.
2. Scroll down to Program. Press **ENTER**.
3. Scroll down to Measurement. Press **ENTER**.

4. Select Sensor 1 or Sensor 2 corresponding to turbidity. Press **ENTER**. [Figure 6-83](#) appear; factory default settings are shown.

Figure 6-83: Configure Turbidity Screen

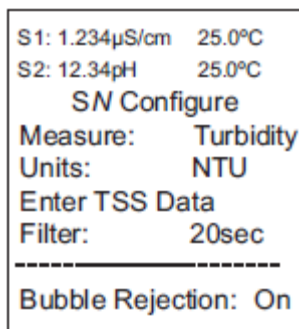

5. To change a setting, scroll to the desired item and press **ENTER**.

6.9.1 Select turbidity measurement

The display screen for selecting the measurement is shown.

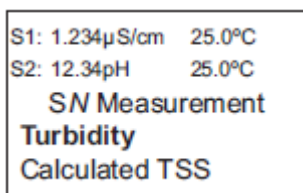

The default value is displayed in **bold type**.

Procedure

Refer to [Figure 6-82](#) to complete this function.

6.9.2 Select turbidity units

The display screen for selecting the measurement units is shown.

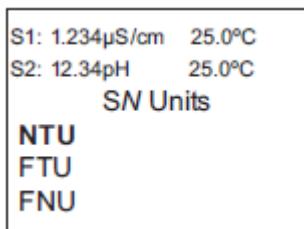

The default value is displayed in **bold type**.

Procedure

Refer to [Figure 6-82](#) to complete this function.

If you select the total suspended solids (TSS) calculation, the following screen will be displayed.

```
S1: 1.234µS/cm  25.0°C
S2: 12.34pH    25.0°C
      SN Units
ppm
mg/L
none
```

6.9.3 Enter TSS Data

The display screen for selecting total suspended solids (TSS) data is shown.

```
S1: 1.234µS/cm  25.0°C
S2: 12.34pH    25.0°C
      SN TSS Data
Pt1 TSS:      0.000ppm
Pt1 Turbid:   0.000NTU
Pt2 TSS:      100.0ppm
Pt2 Turbid:   100.0NTU
-----
Calculate
```

The default values are displayed.

Procedure

1. Refer to [Figure 6-82](#) to complete this function.

Note

Based on user-entered NTU data, calculating TSS as a straight line curve could cause TSS to go below zero. The following screen lets you know that TSS will become zero below a certain NTU value.

```
S1: 1.234µS/cm  25.0°C
S2: 12.34pH    25.0°C
      SN TSS Data
Calculation Complete
Calculated TSS = 0 below
xxxx NTU
```

[Figure 6-84](#) shows the potential for calculated TSS to go below zero.

Figure 6-84: TSS and Turbidity

- A. Normal case: TSS is always a positive number when turbidity is a positive number.
- B. Abnormal case: TSS can be a negative number when turbidity is a positive number.

2. After entering TSS data, press **ENTER**.
The display confirms the determination of a TSS straight line curve fit to the entered NTU/turbidity data by displaying this screen:

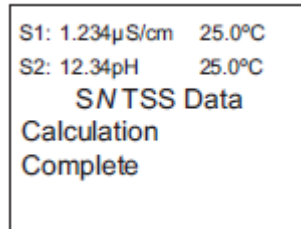

The following screen may appear if TSS calculation is unsuccessful.

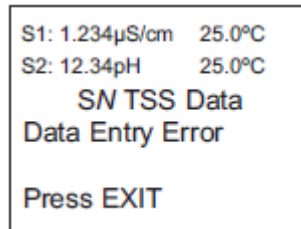

If you see this screen, you need to re-enter NTU and TSS data.

6.9.4 Enter turbidity input filter value

The display screen for entering the input filter value in seconds is shown.

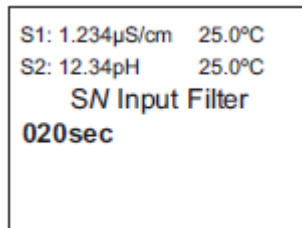

The default value is displayed in **bold type**.

Procedure

Refer to [Figure 6-82](#) to complete this function.

6.9.5 Enable bubble rejection

Bubble rejection is an internal software algorithm that characterizes turbidity readings as bubbles as opposed to true turbidity of the sample. With bubble rejection enabled, these erroneous readings are eliminated from the live measurements shown on the display and transmitted via the current outputs.

The display screen for selecting bubble rejection is shown.

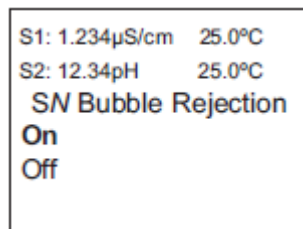

Procedure

Refer to [Figure 6-82](#) to complete this function.

6.10 Program flow measurement

You can configure the transmitter to measure flow using a compatible pulse flow sensor.

Figure 6-85: Flow Measurement Diagram

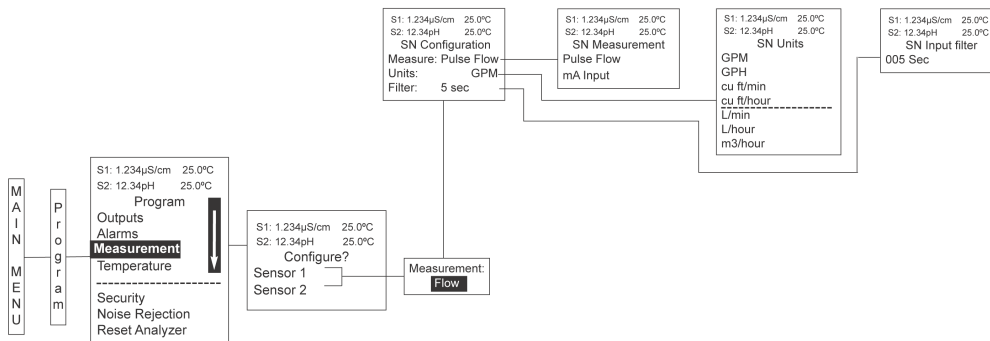

To configure the flow measurement board:

Procedure

1. Press **MENU**.
2. Scroll down to Program. Press **ENTER**.
3. Scroll down to Measurement. Press **ENTER**.
4. Select Sensor 1 or Sensor 2 corresponding to flow. Press **ENTER**.

6.10.1 Select measurement type

Procedure

1. From the **Configure Pulse Flow** screen, select Measure. [Figure 6-86](#) appears. The default measurement is displayed in bold type.

Figure 6-86: Measurement Screen

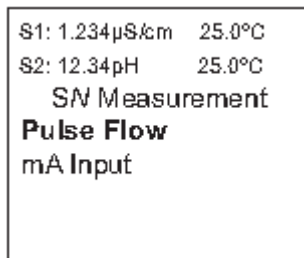

2. Refer to [Figure 6-85](#) to select a measurement type.

6.10.2 Select measurement units

Procedure

1. From the **Configure Pulse Flow** screen, select Units.
[Figure 6-87](#) appears. The default measurement unit is displayed in bold type.

Figure 6-87: Unit Screen

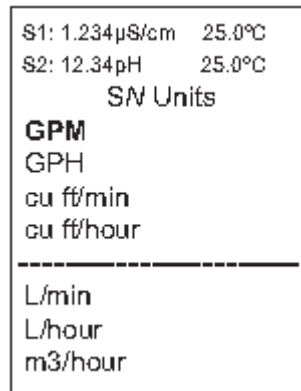

Flow unit options are:

- GPM
- GPH
- cu ft/min
- cu ft/hour
- L/min
- L/hour
- m3/hour

2. Refer to [Figure 6-85](#) to select a measurement unit.

6.10.3 Enter input filter value

Procedure

- From the **Configure Pulse Flow** screen, select Filter.
Figure 6-88 appears. The default value is displayed in bold type.

Figure 6-88: Input Filter Screen

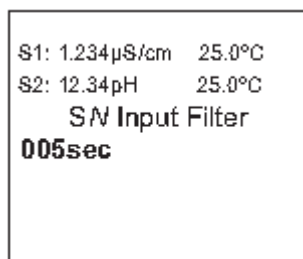

- Refer to Figure 6-85 to enter an input filter value in seconds.

6.11 Program current input measurement

Figure 6-89: Current Input Programming Flow Diagram

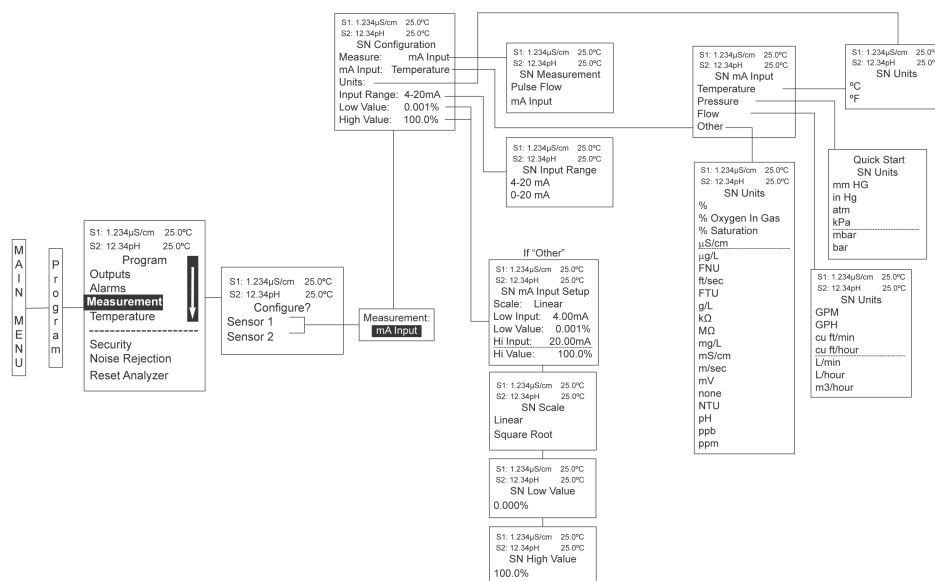

Procedure

1. Press **MENU**.
2. Scroll down to Program. Press **ENTER**.
3. Scroll down to Measurement. Press **ENTER**.
4. Select Sensor 1 or Sensor 2 corresponding to the current input. Press **ENTER**.
The factory default is Pulse Flow, not mA Input.
5. To enable the current input functionality, override the factory default and select mA Input.

[Figure 6-90](#) appears. The default measurement type is displayed in bold font.

Figure 6-90: mA Input Screen

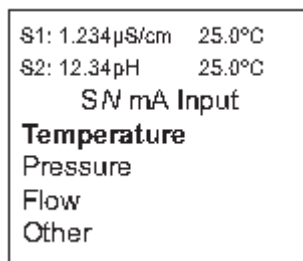

mA input options are:

- Temperature
- Pressure
- Flow
- Other

6. Refer to [Figure 6-89](#) to select an input type.

6.11.1 Select measurement units

Procedure

1. From the **Pulse Flow Configure** screen, select Units.
 - If you selected Temperature as the measurement type, [Figure 6-91](#) appears.

Figure 6-91: Temperature Units Screen

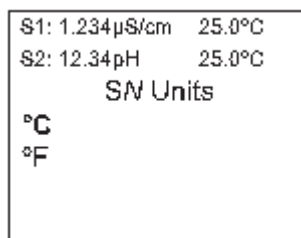

- If you selected Pressure as the measurement type, [Figure 6-92](#) appears.

Figure 6-92: Pressure Units Screen

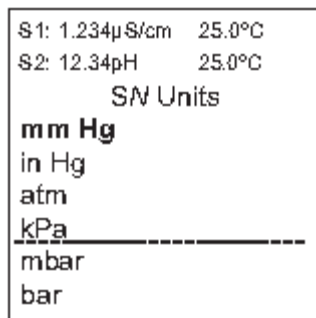

- If you selected Flow as the measurement type, [Figure 6-93](#) appears.

Figure 6-93: Flow Units Screen

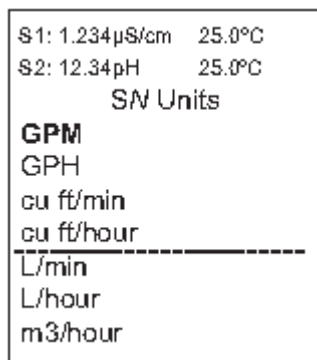

- If you select Other as the measurement type, [Figure 6-94](#) appears.

Figure 6-94: Other Units Screen

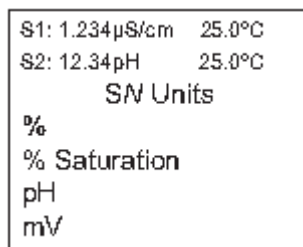

You can also select from the following units:

- μ S/cm
- mS/cm
- M Ω -cm
- k Ω -cm
- ppm
- ppb

- $\mu\text{g/L}$
- mg/L
- g/L
- NTU
- FTU
- FNU
- ft/sec
- m/sec
- none

2. Scroll to the unit of your choice and press **ENTER**.

6.11.2 Select input range

Procedure

1. From the **Pulse Flow Configure** screen, select Input Range. [Figure 6-95](#) appears.

Figure 6-95: Input Range Screen

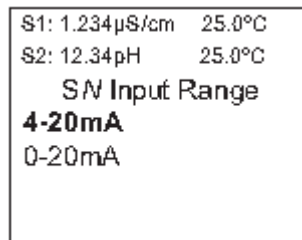

2. Refer to [Figure 6-89](#) to select an input range.

6.11.3 Enter low value

Procedure

1. From the **Puls Flow Configure** screen, select Low Value.
[Figure 6-96](#) appears. The default value is displayed in bold type.

Figure 6-96: Low Value Screen

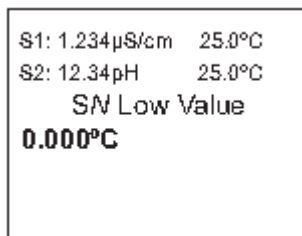

2. Refer to [Figure 6-89](#) to enter a low temperature value.

6.11.4 Enter high value

Procedure

1. From the **Pulse Flow Configure** screen, select High Value.
[Figure 6-97](#) appears. The default value for temperature is displayed in bold type.

Figure 6-97: High Value Screen

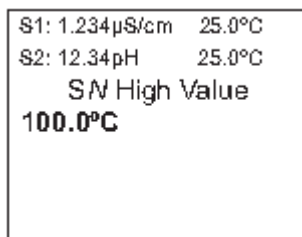

2. Refer to [Figure 6-89](#) to enter the high temperature value.

6.11.5 Enter input filter value

Procedure

1. From the **Pulse Flow Configure** screen, select Filter.
[Figure 6-98](#) appears.

Figure 6-98: Input Filter Screen

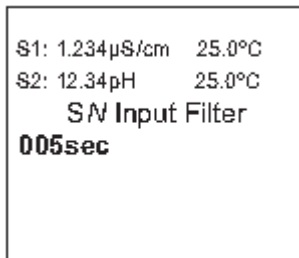

2. Refer to [Figure 6-89](#) to enter an input filter value in seconds.

7 Calibration

Calibration is the process of adjusting or standardizing the transmitter to a lab test or a calibrated laboratory instrument or standardizing to some known reference, such as a commercial buffer.

The transmitter's auto-recognition feature will enable the appropriate calibration screens to allow calibration for any single sensor configuration or dual sensor configuration. Completing the Quick Start when first powering up the transmitter enables live measurement, but does not ensure accurate readings in the lab or in process. Calibrate with each attached sensor to ensure accurate, repeatable readings.

7.1 Calibrate pH sensors

Calibrate new sensors before use and regularly recalibrate them.

Use auto calibration instead of manual calibration. Auto calibration avoids common pitfalls and reduces errors. The transmitter recognizes the buffers and uses temperature-corrected pH values when calibrating. Once the transmitter successfully completes calibration, it calculates and displays the calibration slope and offset. The slope is reported as the slope at 77 °F (25 °C).

Figure 7-1: pH calibration menu tree

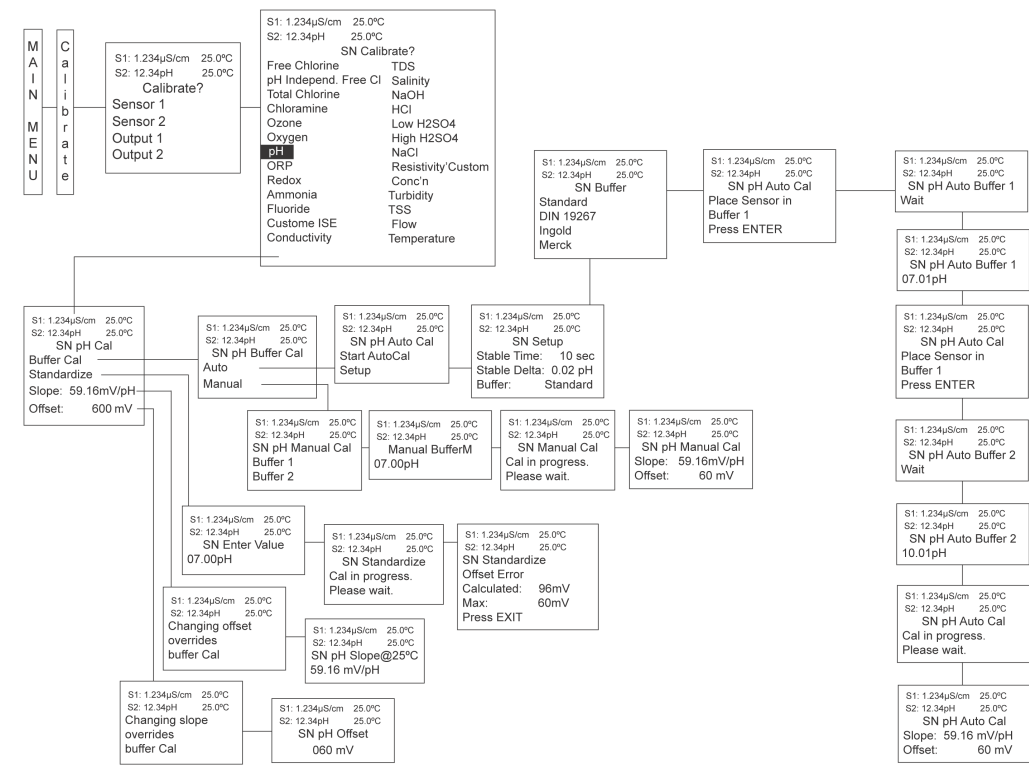

Procedure

1. Press **MENU**.
2. Select Calibrate. Press **ENTER**.

3. Select Sensor 1 or Sensor 2 corresponding to pH. Press **ENTER**.
4. Select pH. Press **ENTER**.

Figure 7-2: pH calibration screen



```
S1: 1.234µS/cm  25.0°C
S2: 12.34pH    25.0°C
      SN pH Cal
Buffer Cal
Standardize
Slope:  59.16mV/pH
Offset:  600 mV
```

5. If desired, change the auto calibration criteria.

Figure 7-3: Set up Auto Calibration Screen

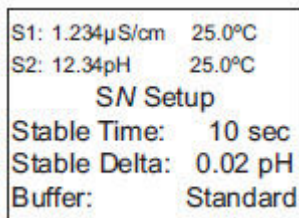

```
S1: 1.234µS/cm  25.0°C
S2: 12.34pH    25.0°C
      SN Setup
Stable Time:  10 sec
Stable Delta: 0.02 pH
Buffer:       Standard
```

You can adjust the following:

- Stabilization time (default 10 seconds)
- Stabilization pH value (default 0.02 pH)
- Type of buffer used for auto calibration (default is standard, non-commercial buffers)

The transmitter recognizes the following commercial buffer tables:

- Standard (NIST plus pH 7)
- DIN 19267
- Ingold
- Merck

Figure 7-4 appears if the auto calibration is successful:

Figure 7-4: pH Auto Calibration Screen

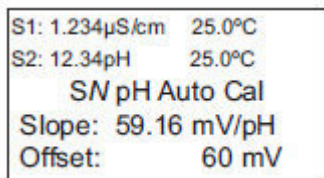

```
S1: 1.234µS/cm  25.0°C
S2: 12.34pH    25.0°C
      SN pH Auto Cal
Slope: 59.16 mV/pH
Offset: 60 mV
```

Figure 7-5 through Figure 7-7 may appear if the auto calibration is unsuccessful.

Figure 7-5: High Slope Error

```
S1: 1.234µS/cm  25.0°C
S2: 12.34pH    25.0°C
  SN pH Auto Cal
High Slope Error
Calculated: 62.11 mV/pH
Max: 62.00 mV/pH
Press EXIT
```

Figure 7-6: Low Slope Error

```
S1: 1.234µS/cm  25.0°C
S2: 12.34pH    25.0°C
  SN pH Auto Cal
Low Slope Error
Calculated: 39.11mV/pH
Min: 40.00 mV/pH
Press EXIT
```

Figure 7-7: Offset Error

```
S1: 1.234µS/cm  25.0°C
S2: 12.34pH    25.0°C
  SN pH Auto Cal
Offset Error
Calculated:  61.22mV
Max:         60.00mV
Press EXIT
```

7.1.1 Calibrate pH sensors manually

Use manual calibration only if using non-standard buffers. Otherwise, use auto calibration. Auto calibration avoids common pitfalls and reduces errors.

Figure 7-8: Manual Calibration Screen

```
S1: 1.234µS/cm  25.0°C
S2: 12.34pH    25.0°C
  SN pH Manual Cal
Buffer 1
Buffer 2
```

7.1.2 Enter a known slope value for pH sensors

Procedure

If you know the electrode slope from other measurements, enter it directly in the transmitter.

Enter the slope as the slope at 77.0 °F (25 °C).

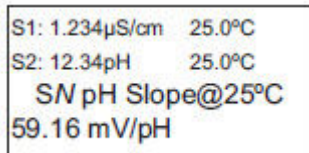

S1: 1.234 μ S/cm 25.0°C
S2: 12.34pH 25.0°C
SN pH Slope@25°C
59.16 mV/pH

7.1.3 Standardize pH sensors

You can change the pH measured by the transmitter to match the reading from a second or referee instrument. The process of making the two readings agree is called standardization.

During standardization, the difference between the two pH values is converted to the equivalent voltage. The voltage, called the referee offset, is added to all subsequent measured cell voltages before they are converted to pH. If you place a standardized sensor in a buffer solution, the measured pH will differ from the buffer pH by an amount equivalent to the standardization offset.



S1: 1.234 μ S/cm 25.0°C
S2: 12.34pH 25.0°C
SN Enter Value
07.00pH

7.2 Calibrate oxidation reduction potential (ORP) sensors

For process control, it is often important to make the measured ORP agree with the ORP of a standard solution. During calibration, the transmitter makes the measured ORP equal to the ORP of a standard solution at a single point.

Figure 7-9: Calibrate ORP menu tree

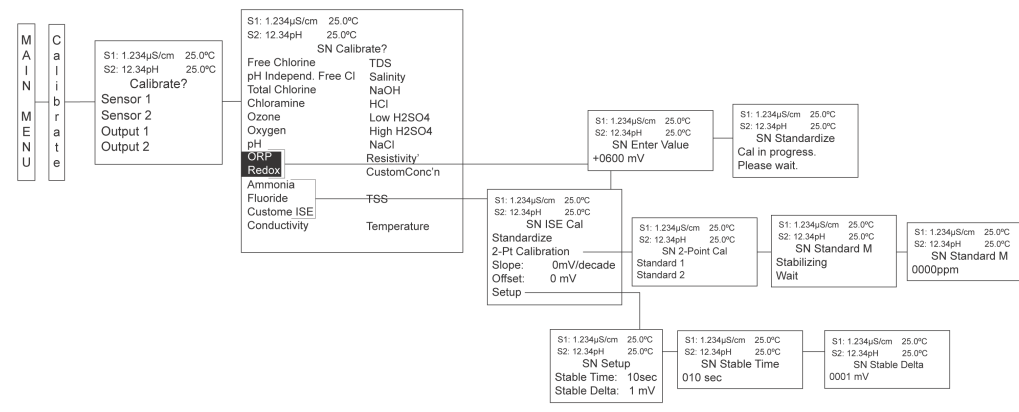

Procedure

1. Press **MENU**.
2. Select Calibrate. Press **ENTER**.
3. Select Sensor 1 or Sensor 2 corresponding to ORP. Press **ENTER**.

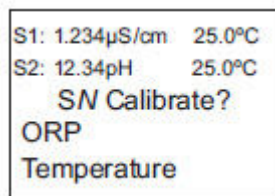

4. Select ORP. Press **ENTER**.

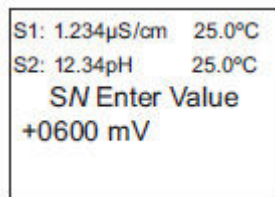
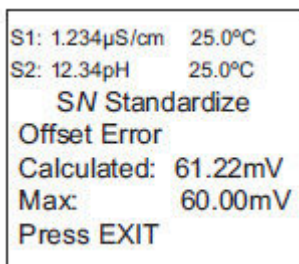

Figure 7-10 may appear if ORP calibration is unsuccessful.

Figure 7-10: Offset Error



7.3 Calibrate contacting conductivity sensors

Placing a new conductivity sensor in service

New conductivity sensors rarely need calibration. The cell constant printed on the label is accurate enough for most applications.

Figure 7-11: Calibrate conductivity sensors menu tree

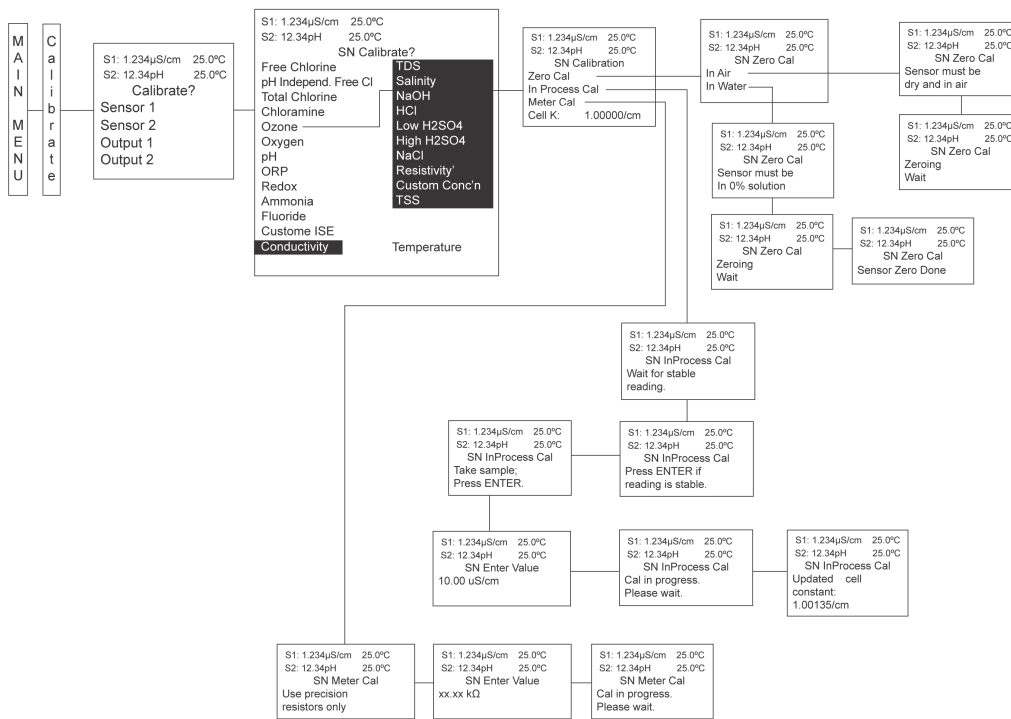

Calibrating an in-service conductivity sensor

After a conductivity sensor has been in service for a period of time, you may need to recalibrate it. There are three ways to calibrate a conductivity sensor:

1. Use a standard instrument and sensor to measure the conductivity of the process stream. You don't need to remove the sensor from the process piping. The temperature correction used by the standard instrument may not exactly match

the temperature correction used by the Rosemount 1056. To avoid errors, turn off temperature correction in both the transmitter and the standard instrument.

2. Place the sensor in a solution of known conductivity and make the transmitter reading match the conductivity of the standard solution. Use this method if you can easily remove the sensor from the process piping and have a standard available. Be careful using standard solutions with conductivity less than 100 $\mu\text{S}/\text{cm}$. Low conductivity standards are highly susceptible to atmospheric contamination. Avoid calibrating sensors with 0.01/cm cell constants against conductivity standards with conductivity greater than 100 $\mu\text{S}/\text{cm}$. The resistance of these solutions may be too low for an accurate measurement.
3. To calibrate a 0.01/cm sensor, check it against a standard instrument and another 0.01/cm sensor while both sensors are measuring water with conductivity between 5 and 10 $\mu\text{S}/\text{cm}$. To avoid drift caused by absorption of atmospheric carbon dioxide, saturate the sample with air before taking measurements.
To ensure adequate flow past the sensor during calibration, take the sample downstream from the sensor. For best results, use a flow-through standard cell. If the process temperature varies greatly from the ambient temperature, keep the connecting lines short and insulate the flow cell.

To calibrate the Rosemount 1056 with an attached conductivity sensor:

Procedure

1. Press **MENU**.
2. Select Calibrate. Press **ENTER**.
3. Select Sensor 1 or Sensor 2 corresponding to conductivity. Press **ENTER**.

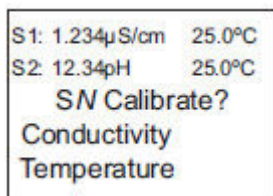

S1: 1.234 $\mu\text{S}/\text{cm}$ 25.0 $^{\circ}\text{C}$
S2: 12.34pH 25.0 $^{\circ}\text{C}$
SN Calibrate?
Conductivity
Temperature

4. To calibrate conductivity or temperature, scroll to the desired item and press **ENTER**.

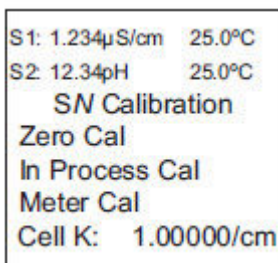

S1: 1.234 $\mu\text{S}/\text{cm}$ 25.0 $^{\circ}\text{C}$
S2: 12.34pH 25.0 $^{\circ}\text{C}$
SN Calibration
Zero Cal
In Process Cal
Meter Cal
Cell K: 1.00000/cm

5. Enter a cell constant only if you are installing the sensor for the first time, replacing the probe, or troubleshooting.

This procedure sets up the transmitter for the probe type connected to it. Each type of probe has a specific cell constant.

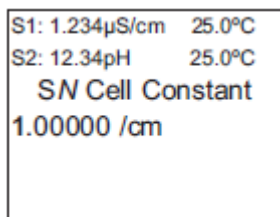

S1: 1.234 μ S/cm 25.0 $^{\circ}$ C
S2: 12.34pH 25.0 $^{\circ}$ C
SN Cell Constant
1.00000 /cm

7.3.1 Zero the transmitter

The purpose of zeroing the transmitter is to compensate for small offsets to the conductivity signal that are present even when there is no conductivity to be measured. This procedure is affected by the length of extension cable. Always repeat it if you make any changes in the extension cable or sensor.

Prerequisites

⚠ CAUTION

Ensure that the probe is dry.

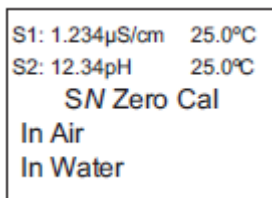

S1: 1.234 μ S/cm 25.0 $^{\circ}$ C
S2: 12.34pH 25.0 $^{\circ}$ C
SN Zero Cal
In Air
In Water

Procedure

1. Zero the transmitter by electrically connecting the conductivity probe as it will actually be used and placing the measuring portion of the probe in the air.
2. Select Zero Cal from the **Conductivity Calibration** screen.

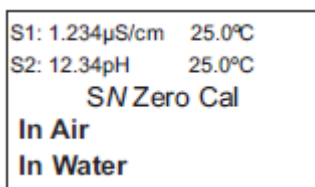

S1: 1.234 μ S/cm 25.0 $^{\circ}$ C
S2: 12.34pH 25.0 $^{\circ}$ C
SN Zero Cal
In Air
In Water

If zero calibration is successful, [Figure 7-12](#) appears.

Figure 7-12: Successful Zero Calibration

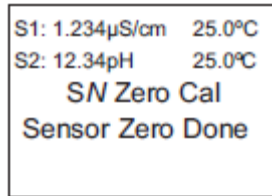

The transmitter returns to the **Conductivity Calibration** screen.

If zero calibration is unsuccessful, [Figure 7-13](#) may appear.

Figure 7-13: Zero Calibration Unsuccessful



7.3.2 Calibrate the sensor in a conductivity standard (In Process Cal)

Use this procedure to check and correct the transmitter's conductivity reading to ensure it is accurate. To do this, calibrate the sensor and transmitter against a solution of known conductivity.

Prerequisites

- Clean the probe.
- If necessary, check and standardize the temperature reading using a calibrated thermometer.

Procedure

1. Submerge the probe in a sample of known conductivity.
2. If necessary, adjust the displayed value to correspond to the conductivity value of the sample.
3. Turn temperature correction off and use the conductivity of the standard.

4. Select In Process Cal from the **Conductivity Calibration** screen.

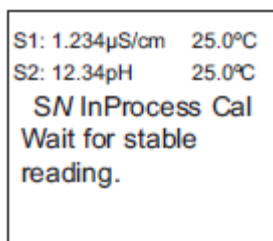

S1: 1.234 μ S/cm 25.0 $^{\circ}$ C
S2: 12.34pH 25.0 $^{\circ}$ C
SN InProcess Cal
Wait for stable
reading.

If in process calibration is successful, [Figure 7-14](#) appears and the transmitter returns to the **Conductivity Calibration** screen.

Figure 7-14: In Process Calibration Successful

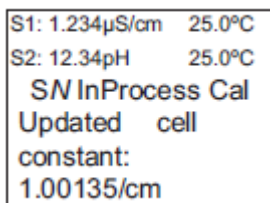

S1: 1.234 μ S/cm 25.0 $^{\circ}$ C
S2: 12.34pH 25.0 $^{\circ}$ C
SN InProcess Cal
Updated cell
constant:
1.00135/cm

If in process calibration is unsuccessful, [Figure 7-15](#) may appear.

Figure 7-15: Calibration Error

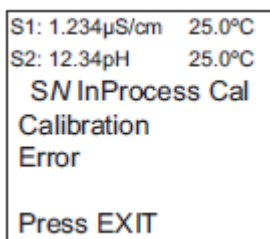

S1: 1.234 μ S/cm 25.0 $^{\circ}$ C
S2: 12.34pH 25.0 $^{\circ}$ C
SN InProcess Cal
Calibration
Error
Press EXIT

7.3.3 Calibrate the sensor to a laboratory instrument (Meter Cal)

Use this procedure to check and correct the conductivity reading of the transmitter using a laboratory conductivity instrument.

Procedure

1. Submerge the conductivity probe in a bath.
2. Measure the conductivity of a grab sample of the same bath water with a separate laboratory instrument.
3. Adjust the transmitter reading to match the conductivity reading of the lab instrument.

4. Select Meter Cal from the **Conductivity Calibration** screen.

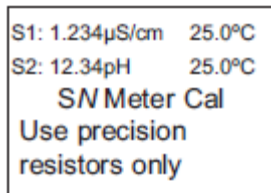

```
S1: 1.234µS/cm 25.0°C
S2: 12.34pH 25.0°C
SN Meter Cal
Use precision
resistors only
```

5. Press **ENTER**.
The display shows the live value measured by the sensor.

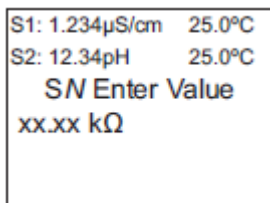

```
S1: 1.234µS/cm 25.0°C
S2: 12.34pH 25.0°C
SN Enter Value
xx.xx kΩ
```

If the meter calibration is successful, the screen returns to the **Conductivity Calibration** screen.

If meter calibration is unsuccessful, [Figure 7-16](#) appears.

Figure 7-16: Meter Calibration Error

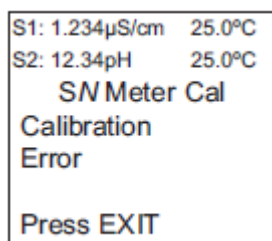

```
S1: 1.234µS/cm 25.0°C
S2: 12.34pH 25.0°C
SN Meter Cal
Calibration
Error
Press EXIT
```

7.3.4 Enter calibration factor

If you selected 4-electrode for the sensor type in the **Quick Start** menus upon initial installation and power up, you need to enter a cell constant and a calibration factor into the transmitter.

The cell constant is needed to convert measured conductance to conductivity as it is displayed on the transmitter screen. The calibration factor entry is needed to increase the accuracy of the live conductivity readings, especially at low conductivity readings below 20 µS/cm. Both the cell constant and the cal factor are printed on the tag attached to the four-electrode sensor/cable.

If necessary after initial installation and start-up, enter the calibration factor as printed on the sensor tag.

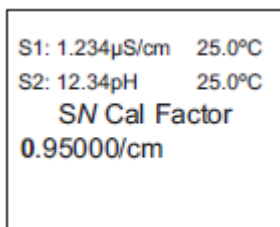

S1: 1.234 μ S/cm 25.0°C
S2: 12.34pH 25.0°C
SN Cal Factor
0.95000/cm

7.4 Calibrate toroidal conductivity sensors

Procedure

1. Press **MENU**.
2. Select Calibrate.
3. Press **ENTER**.
4. Select Sensor 1 or Sensor 2 corresponding to toroidal conductivity.
5. Press **ENTER**.
The following screen appears.

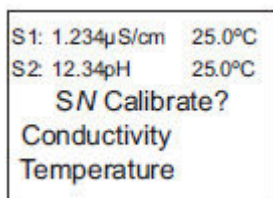

S1: 1.234 μ S/cm 25.0°C
S2: 12.34pH 25.0°C
SN Calibrate?
Conductivity
Temperature

6. Select Conductivity.
The following screen appears.

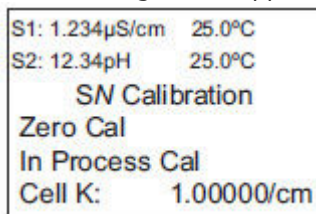

S1: 1.234 μ S/cm 25.0°C
S2: 12.34pH 25.0°C
SN Calibration
Zero Cal
In Process Cal
Cell K: 1.00000/cm

Postrequisites

The following sections show the initial display screen that appears for each calibration routine. Use the live screen prompts to complete calibration.

7.4.1 Entering cell constant

New conductivity sensors rarely need calibration. The cell constant printed on the label is sufficient for most applications.

Enter the cell constant:

- When you install the transmitter for the first time
- When you replace the probe
- When troubleshooting

Setting up the cell constant sets up the transmitter for the probe type connected to it. Each type of probe has a specific cell constant.

For toroidal conductivity sensors, the default value is 3.00000/cm.

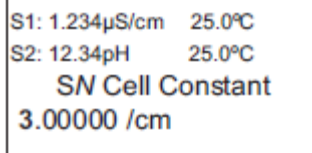

```
S1: 1.234µS/cm 25.0°C
S2: 12.34pH 25.0°C
SN Cell Constant
3.00000 /cm
```

7.4.2 Zero toroidal conductivity sensor

This procedure is used to compensate for small offsets in the conductivity signal that are present even when there is no conductivity to be measured.

This procedure is affected by the length of extension cable. Always repeat it after making any changes in extension cable or sensor.

Procedure

1. Electrically connect the conductivity probe as it will actually be used and place the measuring portion of the probe in air.
2. From the **Conductivity Calibration** screen, select Zero Cal. The following screen appears.

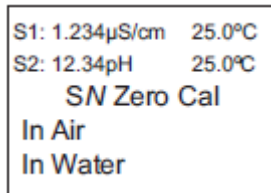

```
S1: 1.234µS/cm 25.0°C
S2: 12.34pH 25.0°C
SN Zero Cal
In Air
In Water
```

If zero calibration is successful the following screen appears.

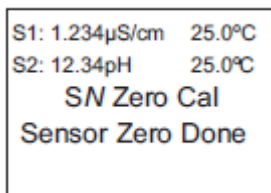

```
S1: 1.234µS/cm 25.0°C
S2: 12.34pH 25.0°C
SN Zero Cal
Sensor Zero Done
```

The screen returns to the **Conductivity Calibration** menu.

The following screen may appear if the zero calibration is unsuccessful.



```
S1: 1.234µS/cm 25.0°C
S2: 12.34pH 25.0°C
SN Zero Cal
Sensor Zero Fail
Offset too high
Press EXIT
```

7.4.3 Calibrate toroidal conductivity sensor in a conductivity standard (in process calibration)

This procedure is used to check and correct the conductivity reading of the Rosemount 1056 to ensure that the reading is accurate.

Prerequisites

Clean the probe and check and standardize the temperature reading before performing this procedure.

Procedure

1. Submerge the probe in a sample of known conductivity.
2. Select In Process Cal from the **Conductivity Calibration** screen. The following screen appears.

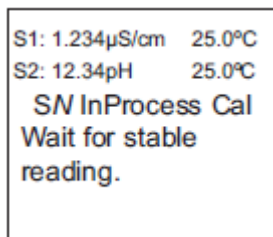

3. Adjust the displayed value on the transmitter, if necessary, to correspond to the conductivity value of the sample.

The following screen will appear if in process calibration is successful.

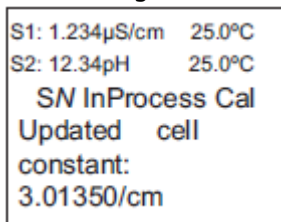

The screen returns to the **Conductivity Calibration** menu.

The following screen may appear if in process calibration is unsuccessful.

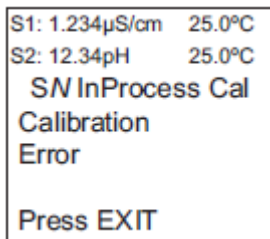

The screen returns to the **Conductivity Calibration** menu.

7.5 Chlorine calibration

With a chlorine measurement board and the appropriate sensor, the transmitter can measure any of the four variants of chlorine.

- Free chlorine
- Total chlorine
- Monochloramine
- pH-independent free chlorine

The following calibration routines are covered in the family of supported chlorine sensors:

- Air calibration
- Zero calibration
- In process calibration

Figure 7-17: Calibrate chlorine menu tree

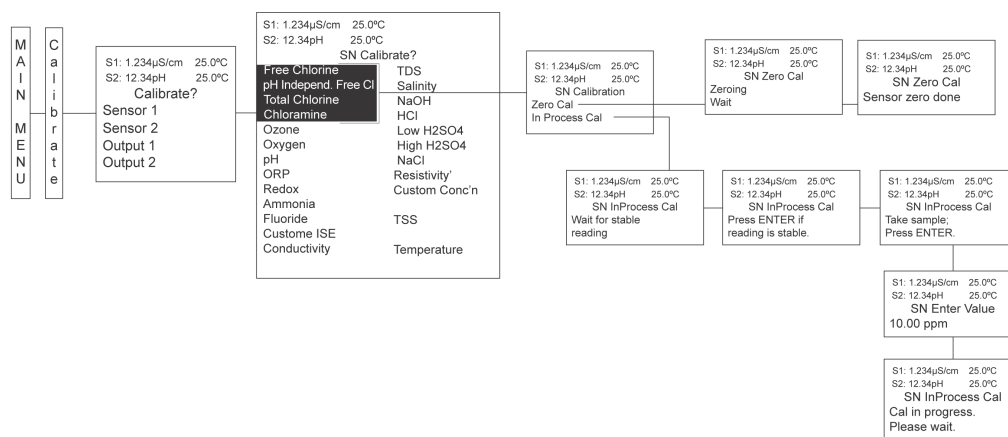

7.5.1 Calibrate free chlorine sensors

A free chlorine sensor generates a current directly proportional to the concentration of free chlorine in the sample. Calibrating the sensor requires exposing it to a solution containing no chlorine (zero standard) and to a solution containing a known amount of chlorine (full-scale standard).

Zero calibration is necessary, because chlorine sensors, even when no chlorine is present in the sample, generate a small current called the residual current. The transmitter compensates for the residual current by subtracting it from the measured current before converting the result to a chlorine value. Zero new sensors before placing them in service and whenever you replace the electrolyte solution.

Either of the following makes a good zero standard:

- Deionized water containing about 500 ppm sodium chloride. Dissolve 0.02 oz (0.5 g) of table salt in one liter of water.

⚠ CAUTION

Do not use deionized water alone for zeroing the sensor.
The conductivity of the zero water must be greater than 50 $\mu\text{S}/\text{cm}$.

- Tap water known to contain no chlorine. Expose tap water to bright sunlight for at least 24 hours.

The purpose of in process calibration is to establish the slope of the calibration curve. Because stable chlorine standards do not exist, calibrate the sensor against a test run on a grab sample of the in process liquid. Several manufacturers offer portable test kits for this purpose. Observe the following precautions when taking and testing the grab sample:

- Take the grab sample from a point as close to the sensor as possible. Be sure that taking the sample does not alter the flow of the sample to the sensor. It is best to install the sample tap just downstream from the sensor.
- Chlorine solutions are unstable. Run the test immediately after taking the sample. Try to calibrate the sensor when the chlorine concentration is at the upper end of the normal operating range.

To calibrate free chlorine:

Procedure

1. Press **MENU**.
2. Select Calibrate. Press **ENTER**.
3. Select Sensor 1 or Sensor 2 corresponding to free chlorine. Press **ENTER**.
4. Select Free Chlorine. Press **ENTER**.

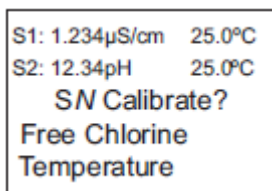

S1: 1.234 $\mu\text{S}/\text{cm}$ 25.0 $^{\circ}\text{C}$
S2: 12.34pH 25.0 $^{\circ}\text{C}$
SN Calibrate?
Free Chlorine
Temperature

After you select Free Chlorine, [Figure 7-18](#) appears.

Figure 7-18: Calibration Screen

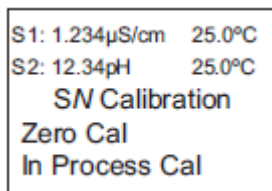

S1: 1.234 $\mu\text{S}/\text{cm}$ 25.0 $^{\circ}\text{C}$
S2: 12.34pH 25.0 $^{\circ}\text{C}$
SN Calibration
Zero Cal
In Process Cal

Related information

[Zero sensor](#)

[Calibrate sensor in process](#)

7.5.2 Calibrate total chlorine sensors

Total chlorine is the sum of free and combined chlorine.

The continuous determination of total chlorine requires two steps. First, the sample flows into a conditioning system (TCL) where a pump continuously adds acetic acid and potassium iodide to the sample. The acid lowers the pH, which allows total chlorine in the sample to quantitatively oxidize the iodide in the reagent to iodine. In the second step, the treated sample flows to the sensor. The sensor is a membrane-covered amperometric sensor, whose output is proportional to the concentration of iodine. Because the concentration of iodine is proportional to the concentration of total chlorine, you can calibrate the transmitter to read total chlorine. Because the sensor really measures iodine, calibrating the sensor requires exposing it to a solution containing no iodine (zero standard) and to a solution containing a known amount of iodine (full-scale standard).

Zero calibration is necessary because the sensor, even when no iodine is present, generates a small current called the residual current. The transmitter compensates for the residual current by subtracting it from the measured current before converting the result to a total chlorine value. Zero new sensors before placing them in service and whenever you replace the electrolyte solution. The best zero standard is deionized water.

Measure in process calibration with the Rosemount TCL Total Chlorine Sample Conditioning System.

Procedure

1. Press **MENU**.
2. Select Calibrate. Press **ENTER**.
3. Select Sensor 1 or Sensor 2 corresponding to total chlorine. Press **ENTER**.
4. Select Total Chlorine. Press **ENTER**.

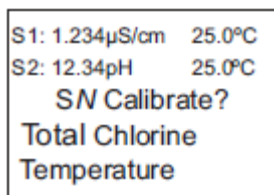

S1: 1.234 μ S/cm 25.0 $^{\circ}$ C
S2: 12.34pH 25.0 $^{\circ}$ C
SN Calibrate?
Total Chlorine
Temperature

5. To calibrate total chlorine or temperature, scroll to the desired item and press **ENTER**.

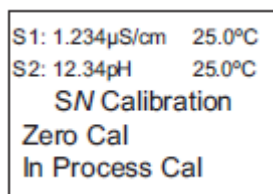

S1: 1.234 μ S/cm 25.0 $^{\circ}$ C
S2: 12.34pH 25.0 $^{\circ}$ C
SN Calibration
Zero Cal
In Process Cal

Related information

[Zero sensor](#)

[Calibrate sensor in process](#)

7.5.3 Calibrate pH-independent free chlorine sensors

A free chlorine sensor generates a current directly proportional to the concentration of free chlorine in the sample. Calibrating the sensor requires exposing it to a solution

containing no chlorine (zero standard) and to a solution containing a known amount of chlorine (full-scale standard).

Zero calibration is necessary because chlorine sensors, even when no chlorine is in the sample, generate a small current called the residual current. The transmitter compensates for the residual current by subtracting it from the measured current before converting the result to a chlorine value. Zero new sensors before placing them in service and whenever you change the electrolyte solution.

Either of the following makes a good zero standard:

- Deionized water
- Tap water known to contain no chlorine. Expose tap water to bright sunlight for at least 24 hours.

Use a pH-independent free chlorine sensor to measure pH-independent free chlorine.

To calibrate pH-independent free chlorine:

Procedure

1. Press **MENU**.
2. Select Calibrate. Press **ENTER**.
3. Select Sensor 1 or Sensor 2 corresponding to pH-independent free chlorine. Press **ENTER**.
4. Select pH Ind. Free Cl. Press **ENTER**.

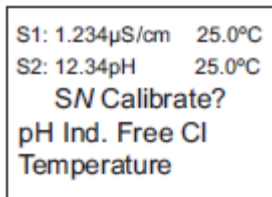

5. To calibrate pH-independent free chlorine or temperature, scroll to the desired item and press **ENTER**.

Related information

[Zero sensor](#)

[Calibrate sensor in process](#)

7.5.4 Calibrate monochloramine sensors

A monochloramine sensor generates a current directly proportional to the concentration of monochloramine in the sample. To calibrate the sensor, expose it to a solution containing no monochloramine (zero standard) and to a solution containing a known amount of monochloramine (full-scale standard).

Zero calibration is necessary because monochloramine sensors, even when no monochloramine is in the sample, generate a small current called the residual or zero current. The transmitter compensates for the residual current by subtracting it from the measured current before converting the result to a monochloramine value.

To calibrate monochloramine:

Procedure

1. Press **MENU**.
2. Select Calibrate. Press **ENTER**.

3. Select Sensor 1 or Sensor 2 corresponding to monochloramine. Press **ENTER**.
4. Select Monochloramine. Press **ENTER**.

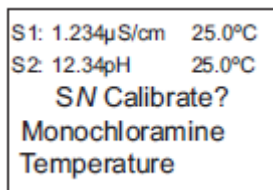

S1: 1.234 μ S/cm 25.0 $^{\circ}$ C
S2: 12.34pH 25.0 $^{\circ}$ C
SN Calibrate?
Monochloramine
Temperature

5. To calibrate monochloramine or temperature, scroll to the desired item and press **ENTER**.

After you select Monochloramine, [Figure 7-19](#) appears.

Figure 7-19: Calibration Screen

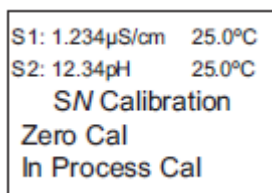

S1: 1.234 μ S/cm 25.0 $^{\circ}$ C
S2: 12.34pH 25.0 $^{\circ}$ C
SN Calibration
Zero Cal
In Process Cal

Related information

[Zero sensor](#)

[Calibrate sensor in process](#)

7.6 Calibrate oxygen sensors

Oxygen sensors generate a current directly proportional to the concentration of dissolved oxygen in the sample. To calibrate an oxygen sensor, you must expose it to a solution

containing no oxygen (zero standard) and to a solution containing a known amount of oxygen (full-scale standard).

Figure 7-20: Calibrate oxygen sensor menu tree

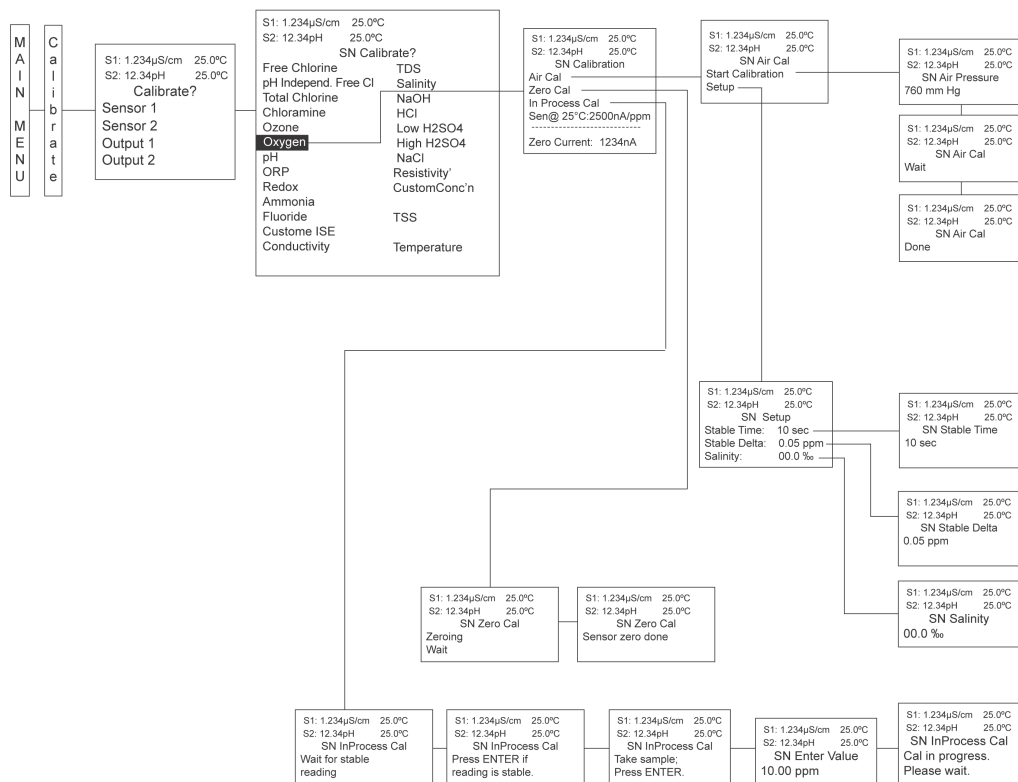

Zero calibration is necessary because oxygen sensors, even when no oxygen is present in the sample, generate a small current called the residual current. The transmitter compensates for the residual current by subtracting it from the measured current before converting the result to a dissolved oxygen value. Zero new sensors before placing them in service and whenever you replace the electrolyte solution. The recommended zero standard is five percent sodium sulfide in water, although you can also use oxygen-free nitrogen. The Rosemount 499ATrDO sensor, used to determine trace (ppb) oxygen levels, has very low residual current and does not normally require zeroing. The residual current in the Rosemount 499ATrDO sensor is equivalent to less than 0.5 ppb oxygen.

The purpose of in process calibration is to establish the slope of the calibration curve. Because the solubility of atmospheric oxygen in water as a function of temperature and barometric pressure is well known, the natural choice for a full-scale standard is air-saturated water. However, air-saturated water is difficult to prepare and use, so the universal practice is to use air for calibration. From the point of view of the oxygen sensor, air and air-saturated water are identical. The equivalence comes about because the sensor really measures the chemical potential of oxygen. Chemical potential is the force that causes oxygen molecules to diffuse from the sample into the sensor where they can be measured. It is also the force that causes oxygen molecules in air to dissolve until the water is saturated with oxygen. Once the water is saturated, the chemical potential of oxygen in the two phases (air and water) is the same.

Oxygen sensors generate a current directly proportional to the rate at which oxygen molecules diffuse through a membrane stretched over the end of the sensor. The diffusion

rate depends on the difference in chemical potential between oxygen in the sensor and oxygen in the sample. An electrochemical reaction, which destroys any oxygen molecules entering the sensor, keeps the concentration (and the chemical potential) of the oxygen inside the sensor equal to zero. Therefore, the chemical potential of oxygen in the sample alone determines the diffusion rate and the sensor current.

When you calibrate the sensor, the chemical potential of oxygen in the standard determines the sensor current. Whether the sensor is calibrated in air or air-saturated water is immaterial. The chemical potential of oxygen is the same in either phase. Normally, to make calculating solubility in common units (like ppm dissolved oxygen) simpler, it is convenient to use water-saturated air for calibration. Automatic air calibration is standard. Simply expose the sensor to water-saturated air. The transmitter measures the sensor current. When the current is stable, the transmitter stores the current and measures the temperature using a temperature element inside the oxygen sensor. Enter the barometric pressure.

From the temperature, the transmitter calculates the saturation vapor pressure of water. Next, it calculates the pressure of dry air by subtracting the vapor pressure from the barometric pressure. Using the fact that dry air always contains at least 20.95 percent oxygen, the transmitter calculates the partial pressure of oxygen. Once the transmitter knows the partial pressure of oxygen, it uses the Bunsen coefficient to calculate the equilibrium solubility of atmospheric oxygen in water at the prevailing temperature. At 77.0 °F (25 °C) and 29.92 in (760 mm) Hg, the equilibrium solubility is 8.24 ppm. Often, it is too difficult or messy to remove the sensor from the process liquid for calibration. In this case, you can calibrate the sensor against a measurement made with a portable laboratory instrument. The laboratory instrument typically uses a membrane-covered amperometric sensor that has been calibrated against water-saturated air.

To calibrate oxygen:

Procedure

1. Press **MENU**.
2. Select Calibrate. Press **ENTER**.
3. Select Sensor 1 or Sensor 2 corresponding to oxygen. Press **ENTER**.
4. Select Oxygen. Press **ENTER**.

S1: 1.234µS/cm	25.0°C
S2: 12.34pH	25.0°C
SN Calibrate?	
Oxygen	
Temperature	

5. To calibrate oxygen or temperature, scroll to the desired item and press **ENTER**.

S1: 1.234µS/cm	25.0°C
S2: 12.34pH	25.0°C
SN Calibration	
Air Cal	
Zero Cal	
In Process Cal	
Sen@ 25°C:2500nA/ppm	
Zero Current: 1234nA	

6. Select Air Cal to adjust air calibration criteria.
You can adjust the following:
 - Stabilization time (default 10 sec)
 - Stabilization pH value (default 0.05 ppm)
 - Salinity of the solution to be measured (default 00.0 parts per thousand)

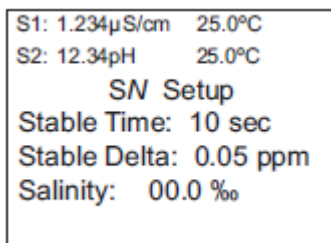

```
S1: 1.234µS/cm 25.0°C
S2: 12.34pH 25.0°C
SN Setup
Stable Time: 10 sec
Stable Delta: 0.05 ppm
Salinity: 00.0 ‰
```

Related information

[Zero sensor](#)
[Calibrate sensor in air](#)
[Calibrate sensor in process](#)

7.6.1 Calibrate sensor in air

Procedure

From the **Oxygen Calibration** screen, select Air Cal.

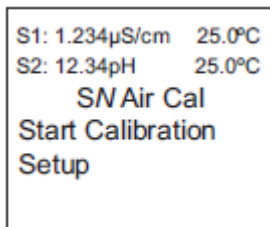

```
S1: 1.234µS/cm 25.0°C
S2: 12.34pH 25.0°C
SN Air Cal
Start Calibration
Setup
```

If air calibration is successful, [Figure 7-21](#) appears.

Figure 7-21: Air Cal Done

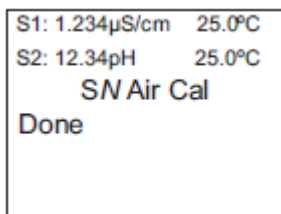

```
S1: 1.234µS/cm 25.0°C
S2: 12.34pH 25.0°C
SN Air Cal
Done
```

The transmitter returns to the **Amperometric Calibration** screen.

If air calibration is unsuccessful, [Figure 7-22](#) appears.

Figure 7-22: Air Cal Failure

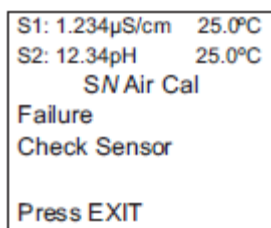

The transmitter returns to the *Amperometric Calibration* screen.

7.7 Calibrate ozone sensors

An ozone sensor generates a current directly proportional to the concentration of ozone in the sample. To calibrate an ozone sensor, you must expose it to a solution containing no ozone (zero standard) and to a solution containing a known amount of ozone (full-scale standard).

Figure 7-23: Calibrate ozone sensor menu tree

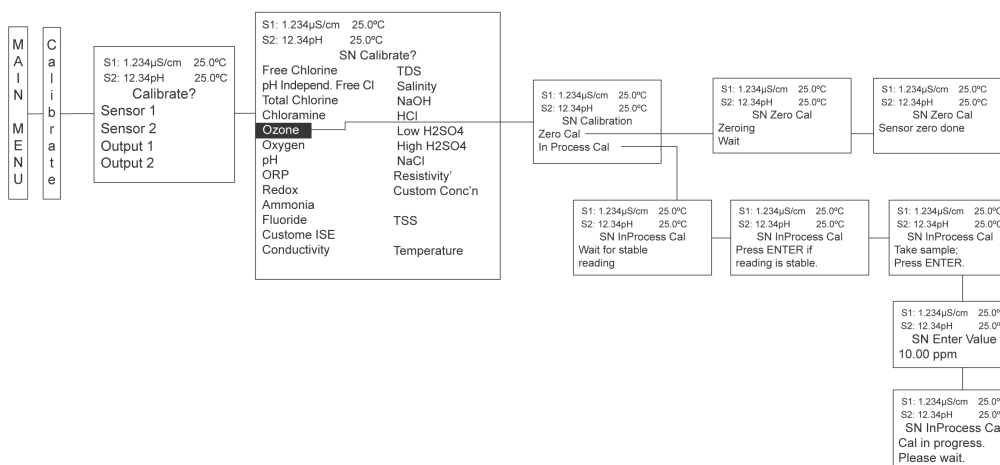

Zero calibration is necessary because ozone sensors, even when no ozone is in the sample, generate a small current called the residual or zero current. The transmitter compensates for the residual current by subtracting it from the measured current before converting the result to an ozone value. Zero new sensors before placing them in service and whenever you replace the electrolyte solution. The best zero standard is deionized water.

To calibrate ozone:

Procedure

1. Press **MENU**.
2. Select Calibrate. Press **ENTER**.
3. Select Sensor 1 or Sensor 2 corresponding to ozone. Press **ENTER**.

4. Select Ozone. Press **ENTER**.

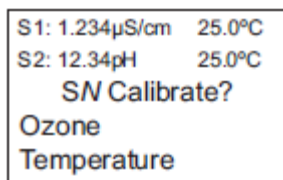

S1: 1.234µS/cm 25.0°C
S2: 12.34pH 25.0°C
SN Calibrate?
Ozone
Temperature

5. To calibrate ozone or temperature, scroll to the desired item and press **ENTER**.

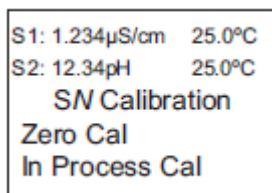

S1: 1.234µS/cm 25.0°C
S2: 12.34pH 25.0°C
SN Calibration
Zero Cal
In Process Cal

Related information

[Zero sensor](#)

[Calibrate sensor in process](#)

7.8 Zero sensor

This procedure applies to amperometric sensors only.

Prerequisites

Run the sensor in the zero solution for at least two hours before zeroing.

Procedure

From the **Calibration** screen, select Zero Cal.

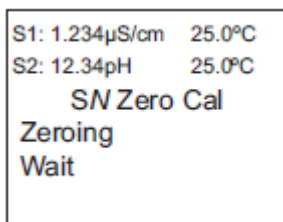

S1: 1.234µS/cm 25.0°C
S2: 12.34pH 25.0°C
SN Zero Cal
Zeroing
Wait

If zero calibration is successful, [Figure 7-24](#) appears.

Figure 7-24: Zero Calibration Successful

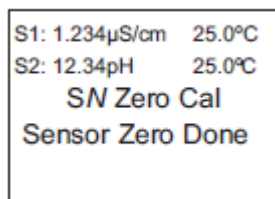

S1: 1.234µS/cm 25.0°C
S2: 12.34pH 25.0°C
SN Zero Cal
Sensor Zero Done

The transmitter returns to the **Amperometric Calibration** screen.

If zero calibration is unsuccessful, [Figure 7-25](#) may appear.

Figure 7-25: Zero Failed

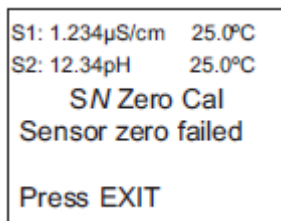

S1: 1.234μS/cm 25.0°C
S2: 12.34pH 25.0°C
SN Zero Cal
Sensor zero failed
Press EXIT

The transmitter returns to the **Amperometric Calibration** screen.

7.9 Calibrate sensor in process

Procedure

From the **Calibration** screen, select In Process Cal.

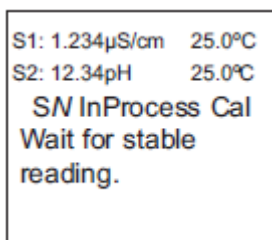

S1: 1.234μS/cm 25.0°C
S2: 12.34pH 25.0°C
SN InProcess Cal
Wait for stable
reading.

If the in process calibration is successful, the transmitter returns to the **Calibration** screen.

If calibration is unsuccessful, [Figure 7-26](#) may appear.

Figure 7-26: Calibration Error

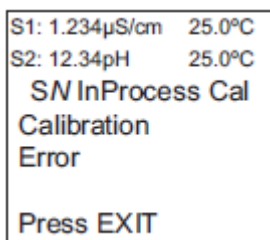

S1: 1.234μS/cm 25.0°C
S2: 12.34pH 25.0°C
SN InProcess Cal
Calibration
Error
Press EXIT

The transmitter returns to the **Amperometric Calibration** screen.

7.10 Calibrate temperature

Most liquid analytical measurements (except oxidation reduction potential [ORP]) require temperature compensation. The transmitter automatically compensates for temperature by applying internal temperature correction algorithms. You can also turn off temperature

correction. If you turn temperature correction off, the transmitter uses the manual temperature you enter in all temperature correction calculations.

To calibrate temperature:

Procedure

1. Press **MENU**.
2. Select Calibrate. Press **ENTER**.
3. Select Sensor 1 or Sensor 2 corresponding to the desired measurement. Press **ENTER**.
4. Select Temperature. Press **ENTER**.

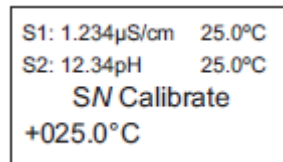

S1: 1.234 μ S/cm 25.0°C
S2: 12.34pH 25.0°C
SN Calibrate
+025.0°C

5. The transmitter calibrates temperature.

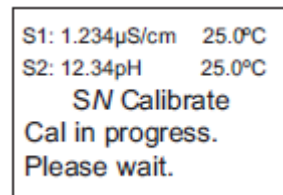

S1: 1.234 μ S/cm 25.0°C
S2: 12.34pH 25.0°C
SN Calibrate
Cal in progress.
Please wait.

6. If the temperature offset is greater than 5 °C from the default value, [Figure 7-27](#) may appear.

Figure 7-27: Temperature Offset Screen

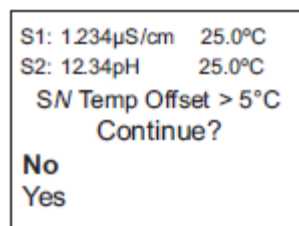

S1: 1.234 μ S/cm 25.0°C
S2: 12.34pH 25.0°C
SN Temp Offset > 5°C
Continue?
No
Yes

7. To continue, select Yes. To suspend the operation, select No.

If the temperature calibration is successful, the transmitter returns to the **Calibration** screen.

Related information

[Enter temperature compensation](#)

7.11 Calibrate turbidity

You can calibrate the turbidity sensor against a user-prepared standard as a two-point calibration with deionized water, against a 20 NTU user-prepared standard as a single point calibration, and against a grab sample using a reference turbidimeter.

Figure 7-28: Turbidity Flow Diagram

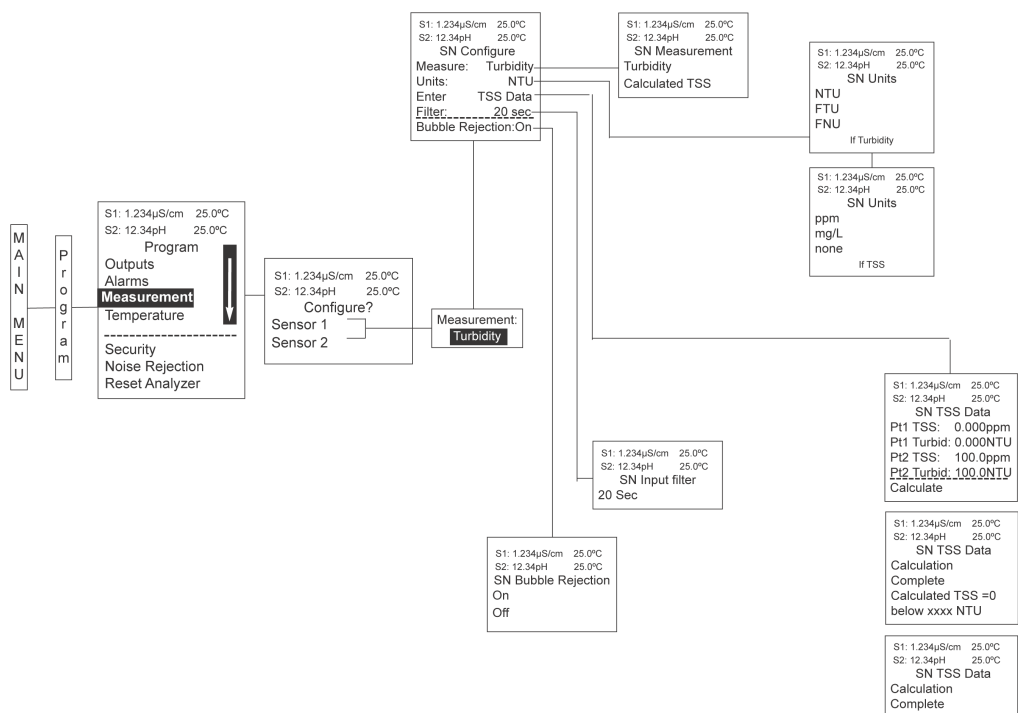

Procedure

1. Press **MENU**.
2. Select Calibrate. Press **ENTER**.
3. Select Sensor 1 or Sensor 2 corresponding to turbidity. Press **ENTER**.
4. Select Turbidity. Press **ENTER**.

Figure 7-29: Calibrate Turbidity Screen

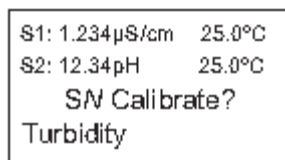
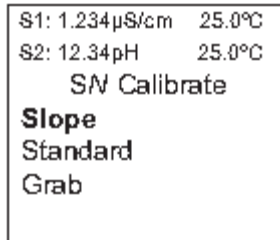

Figure 7-30: Select Calibration Type Screen



7.11.1 Conduct a two-point calibration

Conduct a two-point calibration of the turbidity sensor against a user-prepared 20 NTU standard.

Procedure

1. Immerse the sensor in filtered water having very low turbidity and measure the sensor output.
2. Increase the turbidity of the filtered water by a known amount (typically 20 NTU) and measure the sensor output again.
3. On the transmitter, select Slope.

Figure 7-31: Slope Calibration Screen

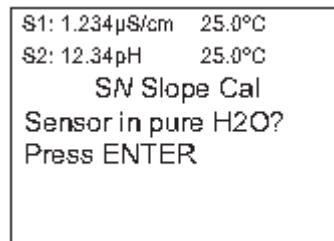

The transmitter takes the two measurements, applies a linear correction (if necessary), and calculates the sensitivity. Sensitivity is the sensor output (in mV) divided by turbidity. A typical new sensor has a sensitivity of about 10 mv. As the sensor ages, the sensitivity decreases. [Figure 7-32](#) illustrates how turbidity two-point calibration works.

Figure 7-32: Turbidity Two-Point Calibration

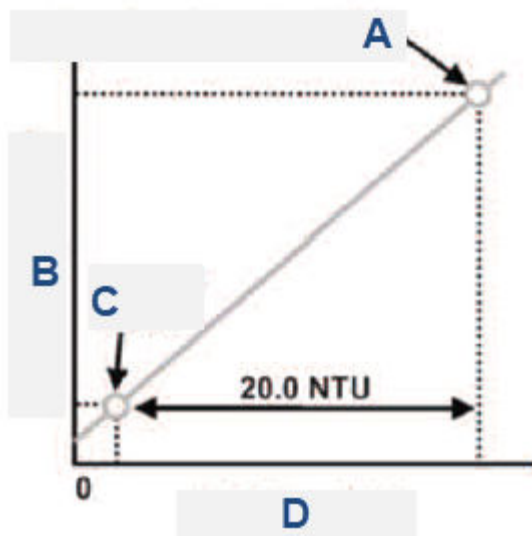

- A. Filtered water + 20.0 ntu
- B. Sensor signal, mV
- C. Filtered water
- D. Turbidity, NTU

Before beginning the calibration, the transmitter does a dark current measurement. Dark current is the signal generated by the detector when no light is falling on it. The transmitter subtracts the dark current from the raw scattered light signal and converts the result to turbidity. In highly filtered samples, which scatter little light, the dark current can be a substantial amount of the signal the sensor generates.

Figure 7-33 appears if the slope calibration is successful.

Figure 7-33: Slope Cal Complete Screen

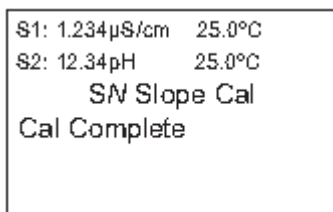

The screen then returns to the **Turbidity Calibration** screen.

Figure 7-34 may appear if the slope calibration is unsuccessful.

Figure 7-34: Slope Calibration Error Screen

```
S1: 1.234µS/cm  25.0°C
S2: 12.34pH    25.0°C
      SN Slope Cal
      Calibration
      Error
      Press EXIT
```

7.11.2 Calibrate against a standard

You can also calibrate a turbidity sensor against a commercial standard.

Stable 20.0 ntu standards are available from a number of sources. Filtered deionized water is not required for this type of calibration.

Procedure

1. On the transmitter, select Standard from the **Calibration** screen.

Figure 7-35: Standard Calibration Screen

```
S1: 1.234µS/cm  25.0°C
S2: 12.34pH    25.0°C
      SN Standard Cal
      Sensor in Standard?
      Press ENTER
```

2. Put the sensor in the standard and press **ENTER** on the transmitter.
Before beginning the calibration, the transmitter does a dark current measurement. Dark current is the signal generated by the sensor even when no light is falling on it. The transmitter subtracts the dark current from the raw scattered light signal and converts the result to turbidity. In highly filtered samples, which scatter little light, the dark current can be a substantial amount of the signal the sensor generates.

Figure 7-36 appears if the standard calibration is successful.

Figure 7-36: Standard Calibration Complete Screen

```
S1: 1.234µS/cm  25.0°C
S2: 12.34pH    25.0°C
      SN Standard Cal
      Cal Complete
```

The transmitter returns to the **Turbidity Calibration** screen.

Figure 7-37 may appear if the standard calibration is unsuccessful.

Figure 7-37: Standard Calibration Error Screen

```
S1: 1.234µS/cm  25.0°C  
S2: 12.34pH    25.0°C  
      SN Standard Cal  
Calibration  
Error  
  
Press EXIT
```

7.11.3 Conduct a grab calibration

You can calibrate the turbidity sensor against the turbidity reading from another sensor.

The transmitter treats the value you enter as though it were the true turbidity of the sample. Therefore, grab sample calibration changes the sensitivity; it does not apply an offset to the reading.

Procedure

1. On the transmitter's **Calibration** screen, select Grab.

Figure 7-38: Grab Calibration Screen

```
S1: 1.234µS/cm  25.0°C  
S2: 12.34pH    25.0°C  
      SN Grab Cal  
Wait for stable  
reading
```

2. Enter the turbidity reading into the transmitter.

[Figure 7-39](#) appears if the grab calibration is successful.

Figure 7-39: Grab Calibration Complete

```
S1: 1.234µS/cm  25.0°C  
S2: 12.34pH    25.0°C  
      SN Grab Cal  
Cal Complete
```

The transmitter returns to the **Turbidity Calibration** screen.

[Figure 7-40](#) may appear if the grab calibration is unsuccessful.

Figure 7-40: Grab Calibration Error

```

S1: 1.234µS/cm  25.0°C
S2: 12.34pH    25.0°C
                SN Grab Cal
Calibration
Error

Press EXIT
    
```

7.12 Calibrate pulse flow sensors

If flow signal boards are installed in the transmitter, you can wire a variety of pulse flow sensors to the flow signal input board to measure flow volume, total volume, and flow difference. The transmitter flow signal board supports flow sensors that are self-driven (powered by the rotation of the impeller paddle-wheel).

Figure 7-41: Pulse Flow Sensor Calibration Diagram

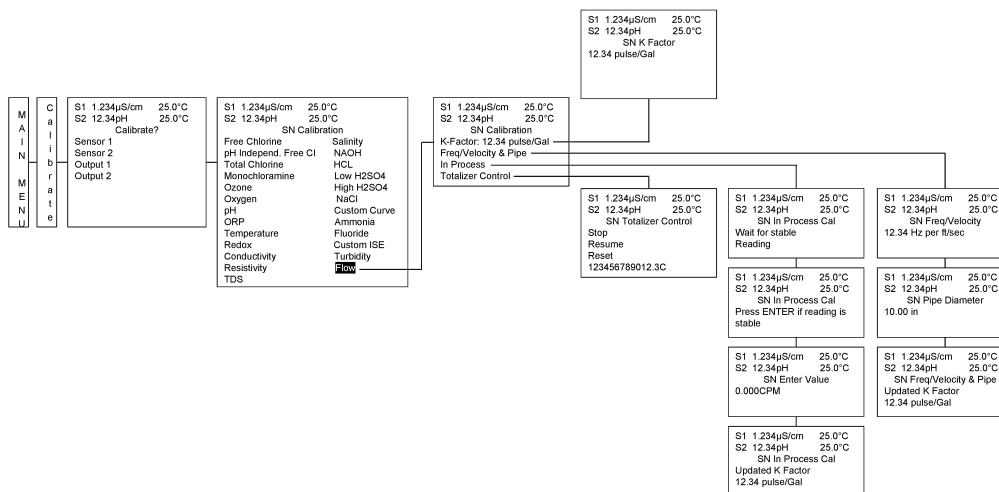

Emerson Confidential

Procedure

1. Press **MENU**.
2. Select Calibrate. Press **ENTER**.
3. Select Sensor 1 or Sensor 2 corresponding to Flow. Press **ENTER**.

4. Select Pulse Flow. Press **ENTER**.
[Figure 7-42](#) appears.

Figure 7-42: Calibrate Pulse Flow Screen

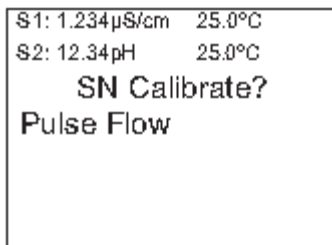

7.12.1 Calibrate pulse flow with K factor

Procedure

1. From the **Pulse Flow Calibration** screen, select K Factor.
[Figure 7-43](#) appears.

Figure 7-43: K Factor Screen

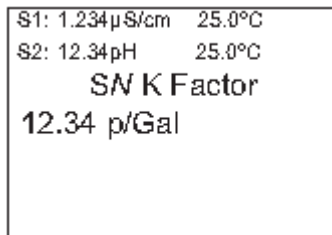

2. Enter the known K factor provided with the flow sensor specifications.
The transmitter returns to the **Pulse Flow Calibration** screen, showing the updated K factor.

7.12.2 Calibrate pulse flow with frequency/velocity ratio and pipe diameter

Procedure

1. From the **Pulse Flow Calibration** screen, select Freq/Velocity & Pipe.
[Figure 7-44](#) appears.

Figure 7-44: Freq/Velocity Screen

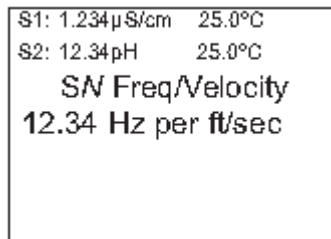

2. Enter the frequency/velocity ratio.
[Figure 7-45](#) appears.

Figure 7-45: Pipe Diameter Screen

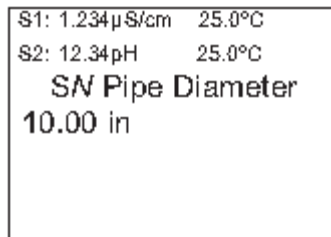

3. Enter the pipe diameter.

If the entries are successful, [Figure 7-46](#) appears.

Figure 7-46: Updated Calibration Screen

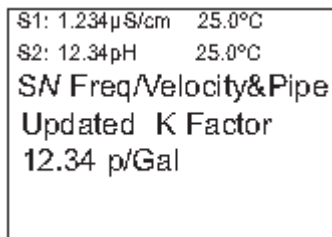

If the results are unsuccessful, [Figure 7-47](#) may appear.

Figure 7-47: Freq/Velocity&&Pipe Calibration Error Screen

```
S1: 1.234µS/cm  25.0°C  
S2: 12.34pH    25.0°C  
SN Freq/Velocity&Pipe  
Calibration  
Error  
  
Press EXIT
```

7.12.3 Calibrate pulse flow in process

Procedure

1. From the **Pulse Flow Calibration** screen, select In Process.
2. Enter the in process calibration.

If the entry is successful, [Figure 7-48](#) appears.

Figure 7-48: In Process Calibration Updated Screen

```
S1: 1.234µS/cm  25.0°C  
S2: 12.34pH    25.0°C  
SN InProcess Cal  
Updated K Factor  
12.34 p/Gal
```

If the entry is unsuccessful, [Figure 7-49](#) may appear.

Figure 7-49: In Process Calibration Error Screen

```
S1: 1.234µS/cm  25.0°C  
S2: 12.34pH    25.0°C  
SN InProcess Cal  
Calibration  
Error  
  
Press EXIT
```

7.12.4 Calibrate pulse flow with totalizer control

Procedure

1. From the **Pulse Flow Calibration** screen, select Totalizer Control.
[Figure 7-50](#) appears.

Figure 7-50: Totalizer Control Screen

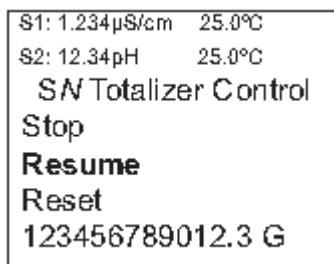

2. To suspend the totalizer, select Stop. To re-enable the totalizer, select Resume. To reset the totalizer count to zero, select Reset.
The live totalizer count result is displayed at the bottom of the **Totalizer Control** screen.

For more information: [Emerson.com/global](https://emerson.com/global)

©2023 Emerson. All rights reserved.

Emerson Terms and Conditions of Sale are available upon request. The Emerson logo is a trademark and service mark of Emerson Electric Co. Rosemount is a mark of one of the Emerson family of companies. All other marks are the property of their respective owners.

ROSEMOUNT™

