

Micro Motion™ 5700 Transmitters

PROFINET Siemens PLC Manual



Safety messages

Safety messages are provided throughout this manual to protect personnel and equipment. Read each safety message carefully before proceeding to the next step.

Safety and approval information

This Micro Motion product complies with all applicable European directives when properly installed in accordance with the instructions in this manual. Refer to the EU Declaration of Conformity for directives that apply to this product. The following are available: the EU Declaration of Conformity, with all applicable European directives, and the complete ATEX installation drawings and instructions. In addition, the IECEx installation instructions for installations outside of the European Union and the CSA installation instructions for installations in North America are available at Emerson.com/global or through your local Micro Motion support center.

Other information

Troubleshooting information can be found in the appropriate Configuration and Use Manual. Product Data Sheets and Manuals are available from the Micro Motion website at Emerson.com/global.

Return policy

Follow Emerson procedures when returning equipment. These procedures ensure legal compliance with government transportation agencies and help provide a safe working environment for Emerson employees. If you fail to follow Emerson procedures, then Emerson will not accept your returned equipment.

Return procedures and forms are available on our web support site at Emerson.com/global, or by calling the Micro Motion Customer Service department.

Contents

Chapter 1	Before you begin.....	5
	1.1 About this document.....	5
	1.2 Related documentation.....	5
Chapter 2	5700 transmitters in Ethernet networks.....	7
	2.1 Star topology.....	7
	2.2 Ring topology.....	8
	2.3 Daisy-chain topology.....	9
Chapter 3	Establish cyclic data.....	10
	3.1 Install the GSDXML file.....	10
	3.2 Create a PROFINET network.....	11
	3.3 Configure Ethernet IP address and device name.....	17
	3.4 Verify communications.....	20
	3.5 Troubleshooting the PROFINET integration.....	22
Chapter 4	Configuring Siemens PLC read/write operation.....	24
Appendix A	Input and output slots.....	32
	A.1 Input slots.....	32
	A.2 Output slots.....	40

1 Before you begin

1.1 About this document

This document provides information about how to integrate a Model 5700 Ethernet transmitter communicating with a Siemens Simatic S7-400 PLC using a Simatic Manager project.

Important

This manual assumes that:

- The transmitter has been installed correctly and completely according to the instructions in the transmitter installation manual.
 - Users understand basic transmitter and sensor installation, configuration, and maintenance concepts and procedures.
-

1.2 Related documentation

You can find all product documentation via the product documentation DVD shipped with the product or at [Emerson.com](https://www.emerson.com).

- [Micro Motion 5700 Transmitters Product Data Sheet](#)
- [Micro Motion 5700 Ethernet Transmitters: Installation Manual](#)
- Hazardous area installation — See the approval documentation shipped with the transmitter, or download the appropriate documentation.

2 5700 transmitters in Ethernet networks

- Make sure that each cable is no longer than 328 ft (100 m).
- Connect the 5700 Ethernet transmitter to the host system via a LAN (Local Area Network) and not a WAN (Wide Area Network).
- Follow all network security best practices.

2.1 Star topology

5700 Ethernet transmitters can be installed in a star network.

Figure 2-1: 5700 star network

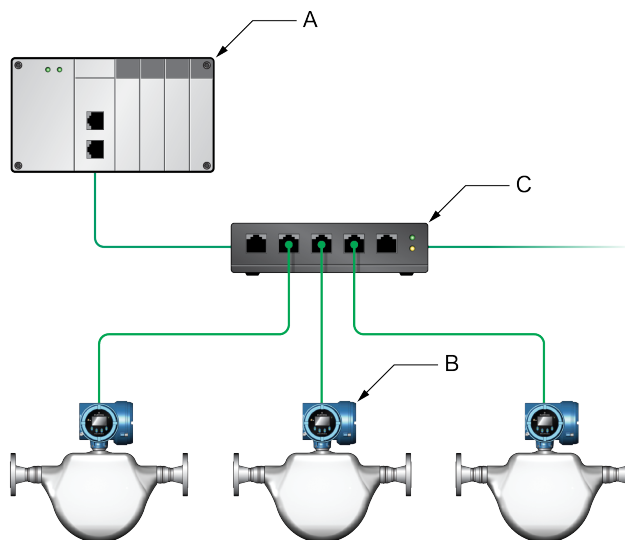

- A. Programmable Logic Controller (PLC)
- B. 5700 with Ethernet output
- C. External Ethernet switch

2.2 Ring topology

5700 Ethernet transmitters can be installed in a ring network.

Figure 2-2: 5700 ring network

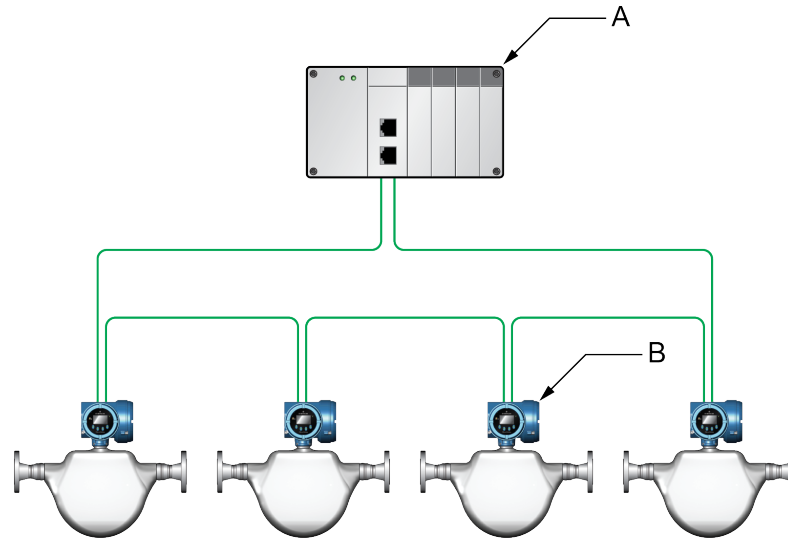

- A. Programmable Logic Controller (PLC)
- B. 5700 with Ethernet output

Note

Ring network topology is not supported if the port mode is set to Independent mode.

2.3 Daisy-chain topology

5700 Ethernet transmitters can be installed in a daisy-chain network.

Figure 2-3: 5700 daisy-chain network

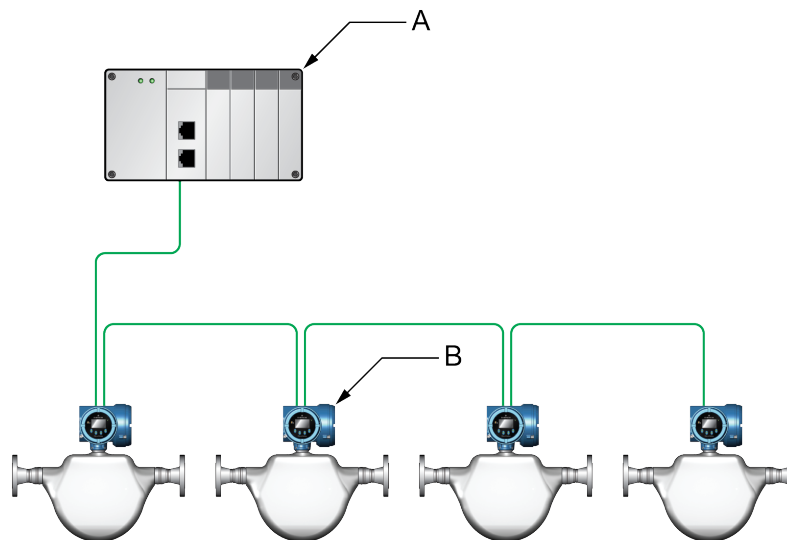

A. Programmable Logic Controller (PLC)

B. 5700 with Ethernet output

Note

Daisy-chain network topology is not supported if the port mode is set to Independent mode.

3 Establish cyclic data

3.1 Install the GSDXML file

Procedure

1. Download the GSDXML file using one of the following methods:

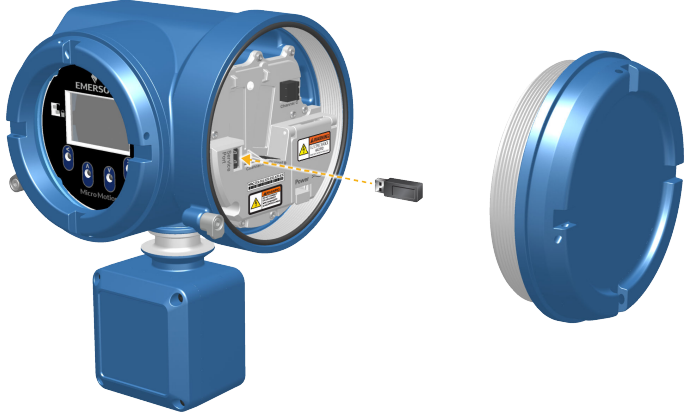
Option	Description
Use a USB memory drive	<ol style="list-style-type: none"> a. Insert a USB memory drive into the 5700 Ethernet service port. The service port connection is located under the transmitter cap.  <ol style="list-style-type: none"> b. From the transmitter display, choose Menu → USB Options → Transmitter → USB Drive → Download Support Files → GSD file. c. Follow the menu to copy the GSDXML file to the USB memory drive. d. Copy the zip file from the USB memory drive to the PC where SIMATIC Manager is installed. e. Unzip the file to a chosen location.
Download the file	<ol style="list-style-type: none"> a. Download the GSDXML file from the Micro Motion 5700 Ethernet product website. b. Unzip the file to a chosen location.

2. To install the 5700 PROFINET GSDXML file into your GSD file catalog using the HW config in SIMATIC Manager:
 - a) Choose **Options** → **Install GSD File**.

Example

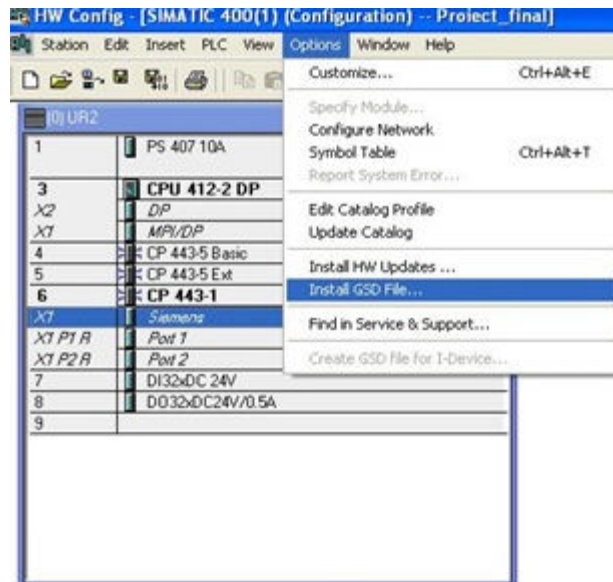

- b) Select **Install**.
- c) Choose **Update Catalog**.

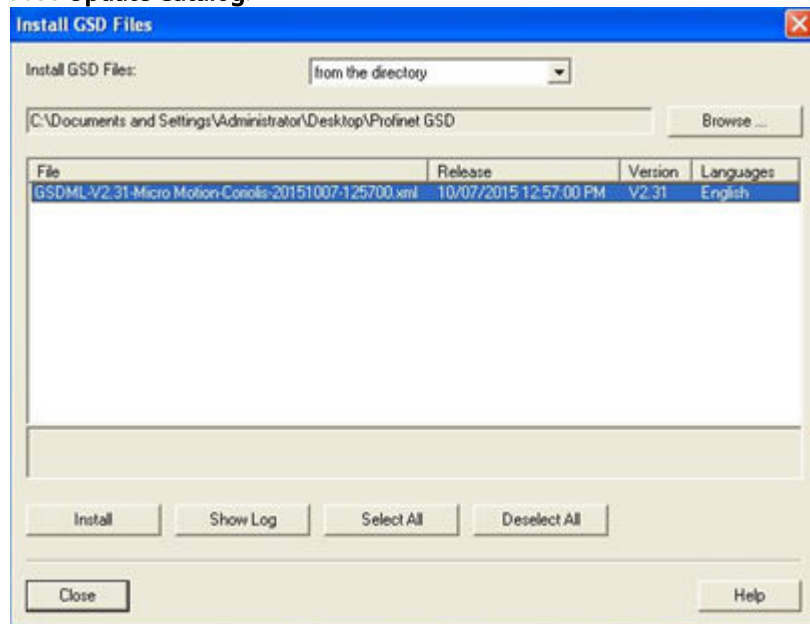

3.2 Create a PROFINET network

Procedure

1. Configure the primary protocol as PROFINET in the 5700 device:
 - a) From the transmitter display, choose **Device Tools** → **Configuration** → **Network Settings**.

b) Select **Profinet**.

- From SIMATIC Manager, choose **File** → **'New Project' Wizard**.
- Follow the wizard to select the CPU for your PLC.

Example

CPU 400

- In the **Component View**, click on the CPU.
- Double-click **Connections**.
A graphical representation of the network is displayed.
- Double-click the CPU icon.
The **HW Config** screen is displayed.
- Double-click the interface, then click **Properties**.

Example

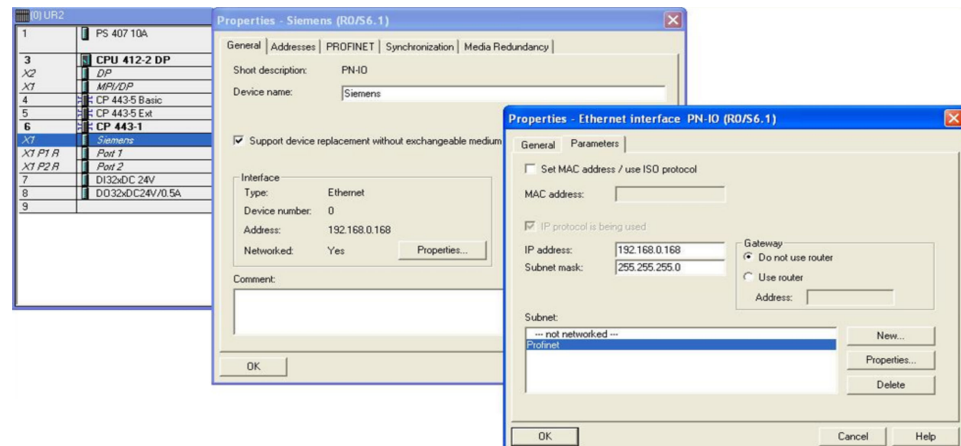

The network settings of the S7 400 PLC Ethernet interface are configured.

- Right-click on the Ethernet interface, and select **Insert PROFINET IO System**.

Example

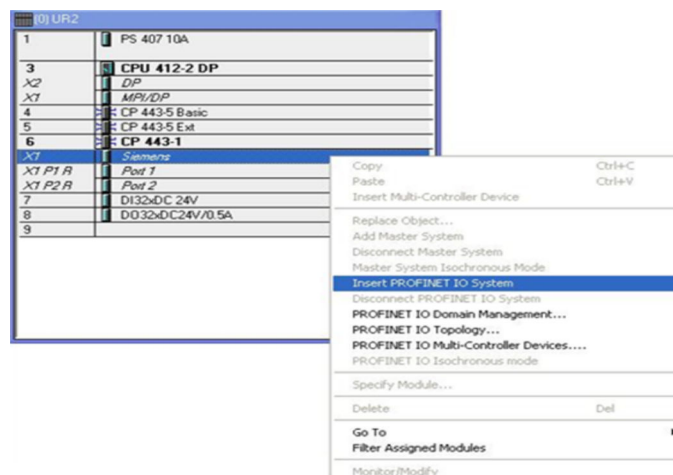

The Ethernet network is created.

- Double-click on the PROFINET network you just created.
The **Properties** menu is displayed.

10. Enter the name of the network.

Example

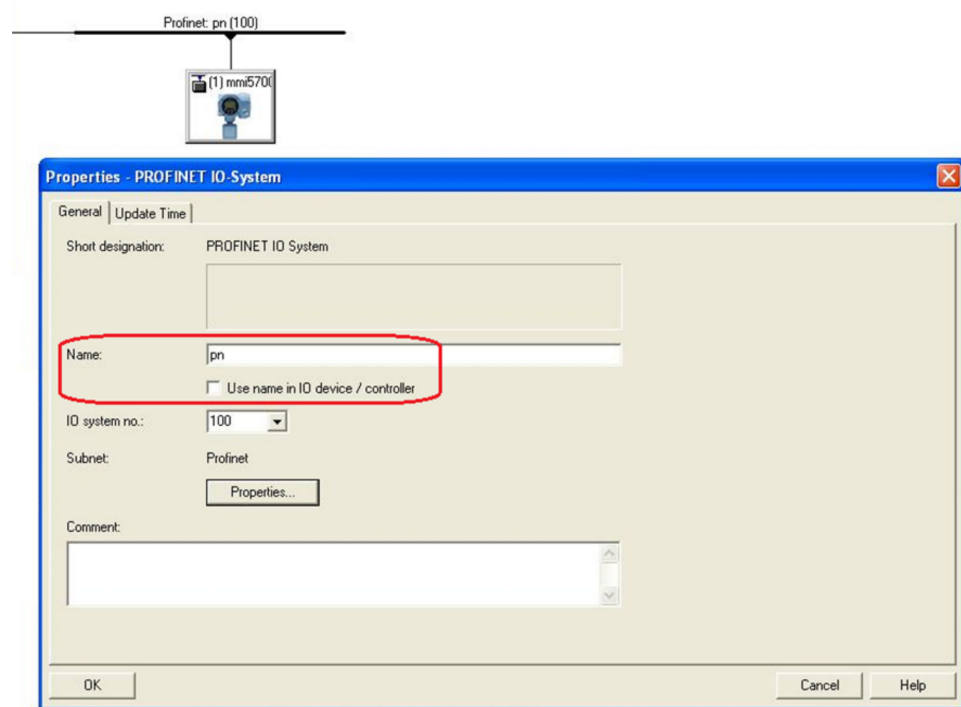

11. (Optional) To use the network name in the IO device and in the controller, check **Use the name in IO device/controller**.
12. Drag and drop the device called **Standard** from the GSD file catalog to the 5700 Ethernet network.
The 5700 Ethernet network is located at **PROFINET IO** → **Additional Field Devices** → **Sensors** → **Coriolis** → **5700 Coriolis Meter**.

Example

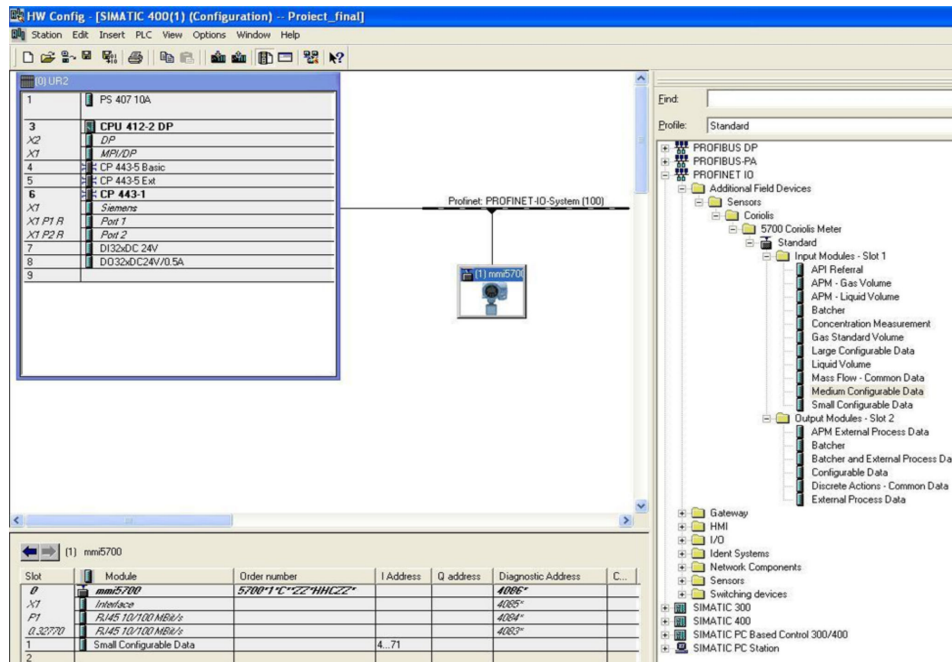

13. Double-click on the device to enter the configuration menu.
14. Enter the **Device name**.

Note

The **Device name** must:

- Follow all DNS conventions
- Cannot start with a number
- Cannot contain uppercase alpha characters

15. Make the appropriate IP address configuration of the device, and press **Ok**. You can use the **Ethernet** button if required.

If the **Use name in IO device/controller** checkbox is checked in the network properties, then **Device name** will have the following format:
device_name.network_name.

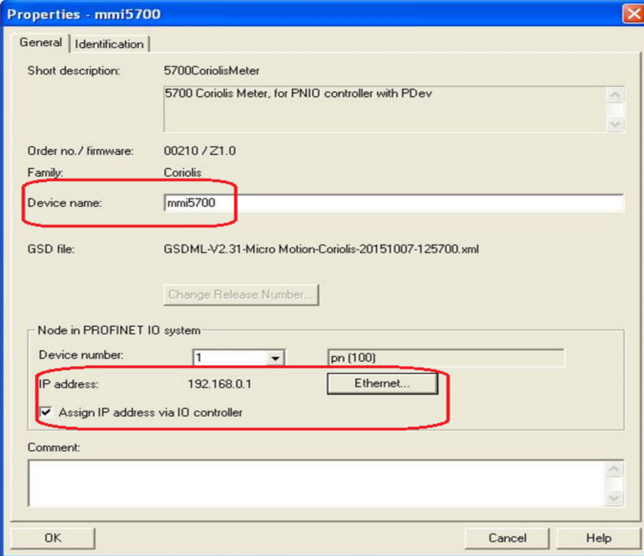
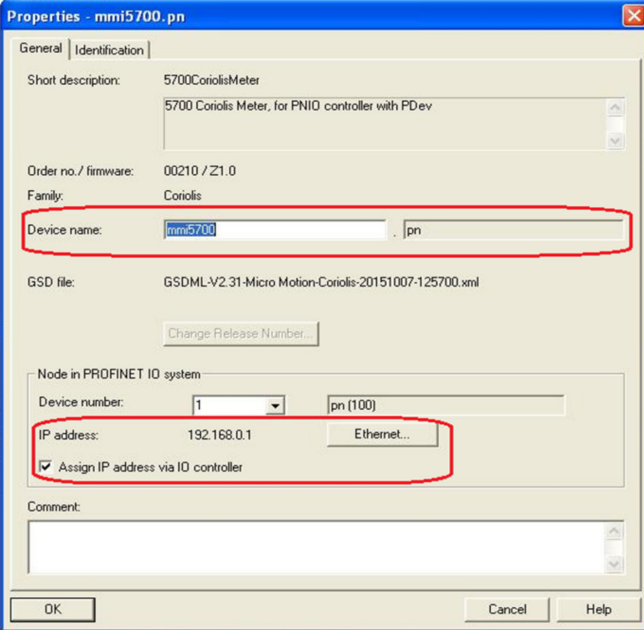
Option	Description
<p>Device name when the Use name in IO device/ controller checkbox is unchecked</p>	
<p>Device name when the Use name in IO device/ controller checkbox is checked</p>	

16. Click on the 5700 Ethernet icon to display the HW configuration in the lower screen.
17. From the HW Catalog, drag the input and output slots to one of the following locations:
 - **PROFINET IO → Additional Field Devices → Sensors → Coriolis → 5700 Coriolis Meter → Standard → Input Modules – Slot 1**

- PROFINET IO → Additional Field Devices → Sensors → Coriolis → 5700 Coriolis Meter → Standard → Output Modules – Slot 2

Example

If **Empty** is selected, delete the slot by right-clicking on the slot, and selecting **Delete**. For a description of the Input and Output slots, see [Input and output slots](#).

Example

In this example, Small Configurable Data has been added to Slot 1.

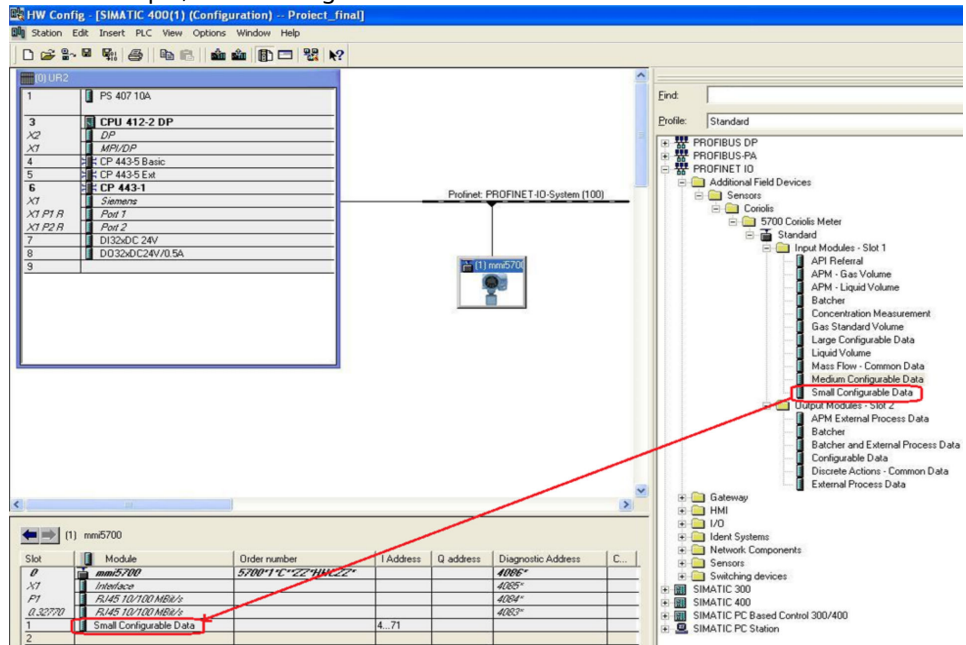

18. Press **Save and Compile**.
19. Press **Download to Module** to download the configuration into the CPU module.

Note

The modules configured and downloaded in the HW Config are set in the transmitter. You do not need to set the Input or Output modules on the transmitter first. You can configure the variables in the input data sets using the web server or ProLink III.

Example

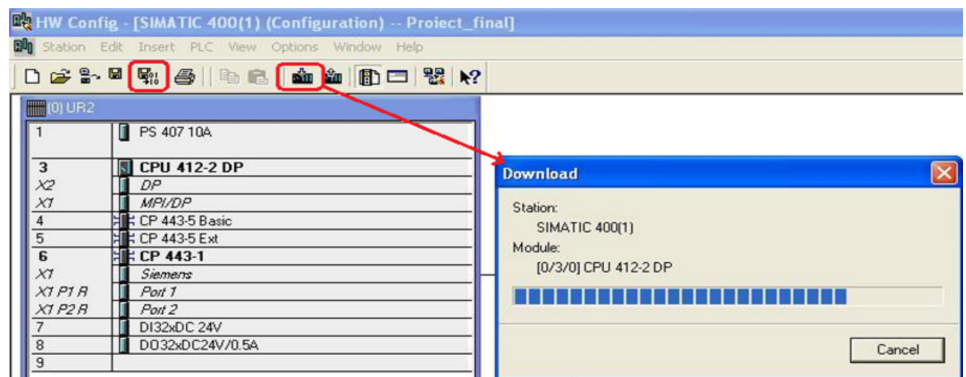

The configuration is downloaded into the CPU module. The PLC should show a red LED bus fault.

3.3 Configure Ethernet IP address and device name

Use this procedure to configure the Ethernet IP address and device name for the Model 5700 Ethernet device.

Procedure

1. Choose **PLC** → **Ethernet** → **Edit Ethernet Node**.

Example

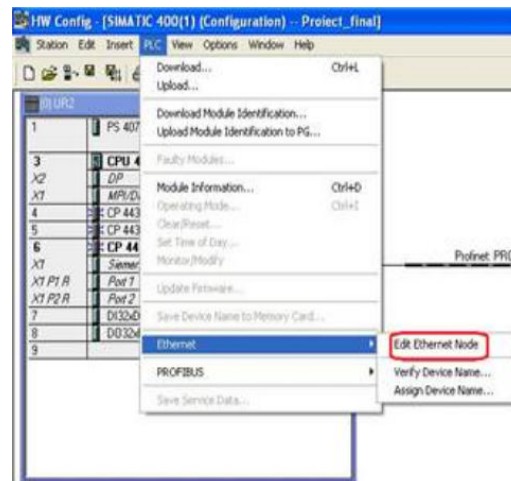

2. To configure the programming machine (PG) to PC interface, choose **Options** → **Set PG/PC Interface...**

Example

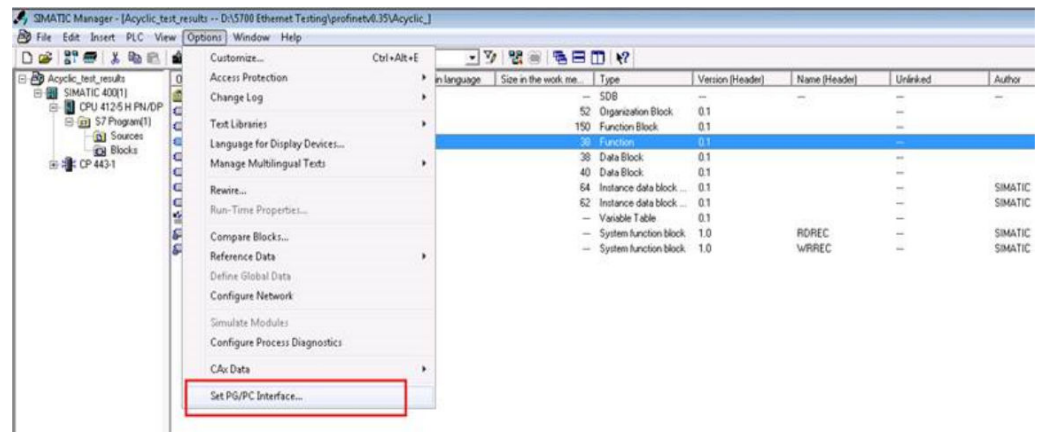

3. Press **Browse** to find the Model 5700 Ethernet device on the network.

Tip

If you cannot find the Model 5700 device, turn off your firewall. Firewalls sometimes prevent SIMATIC Manager from browsing network devices.

Example

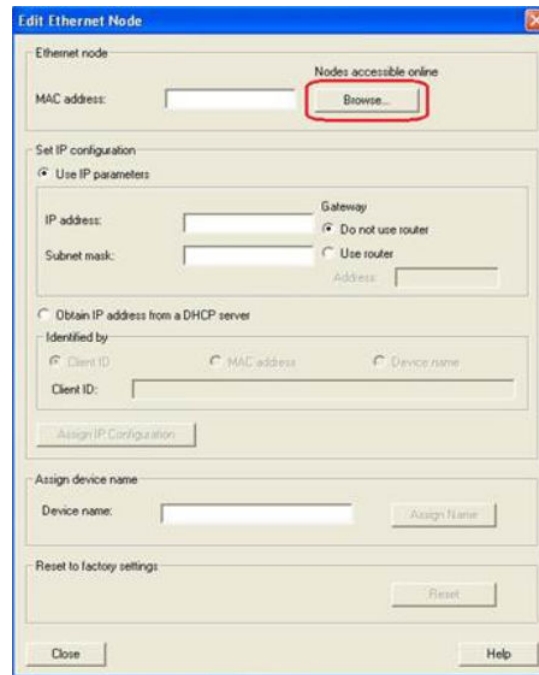

4. Select the device from the list and press **Ok**.

Example

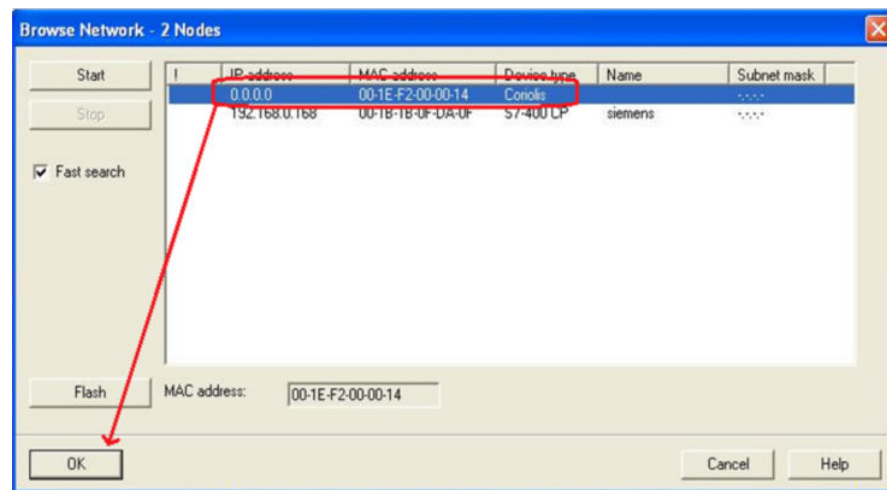

5. Fill in the appropriate network settings and press **Assign IP Configuration**.
6. Fill in the device name and press **Assign Name**.

Make sure the IP configuration and device name are the same as what you configured in [Create a PROFINET network](#).

Example

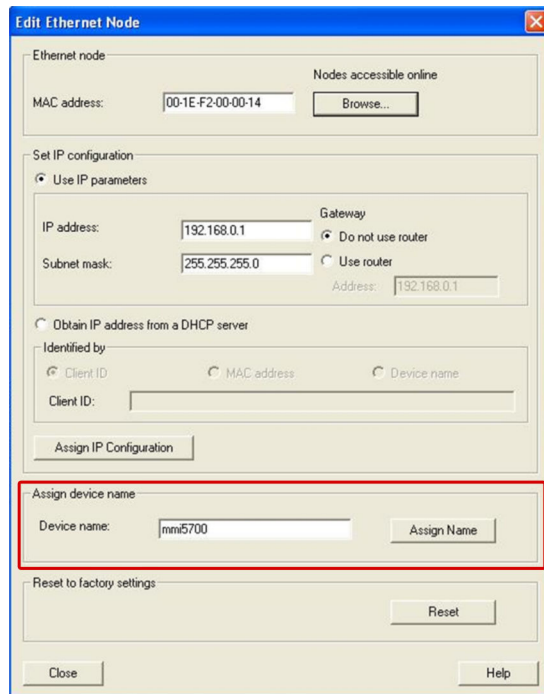

7. Press **Browse** again to make sure the changes were applied to the device.

Example

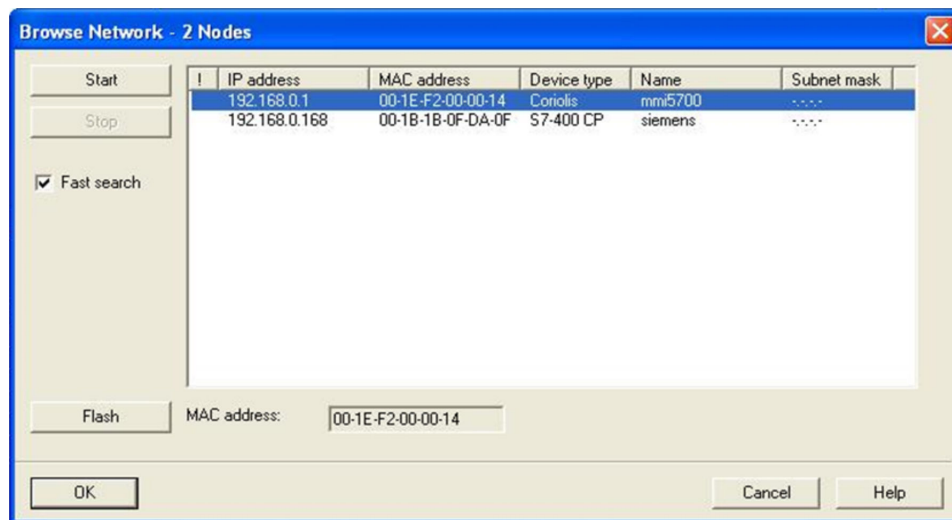

8. Choose **PLC** → **Ethernet** → **Verify Device Name** to verify the device name was properly assigned.

Example

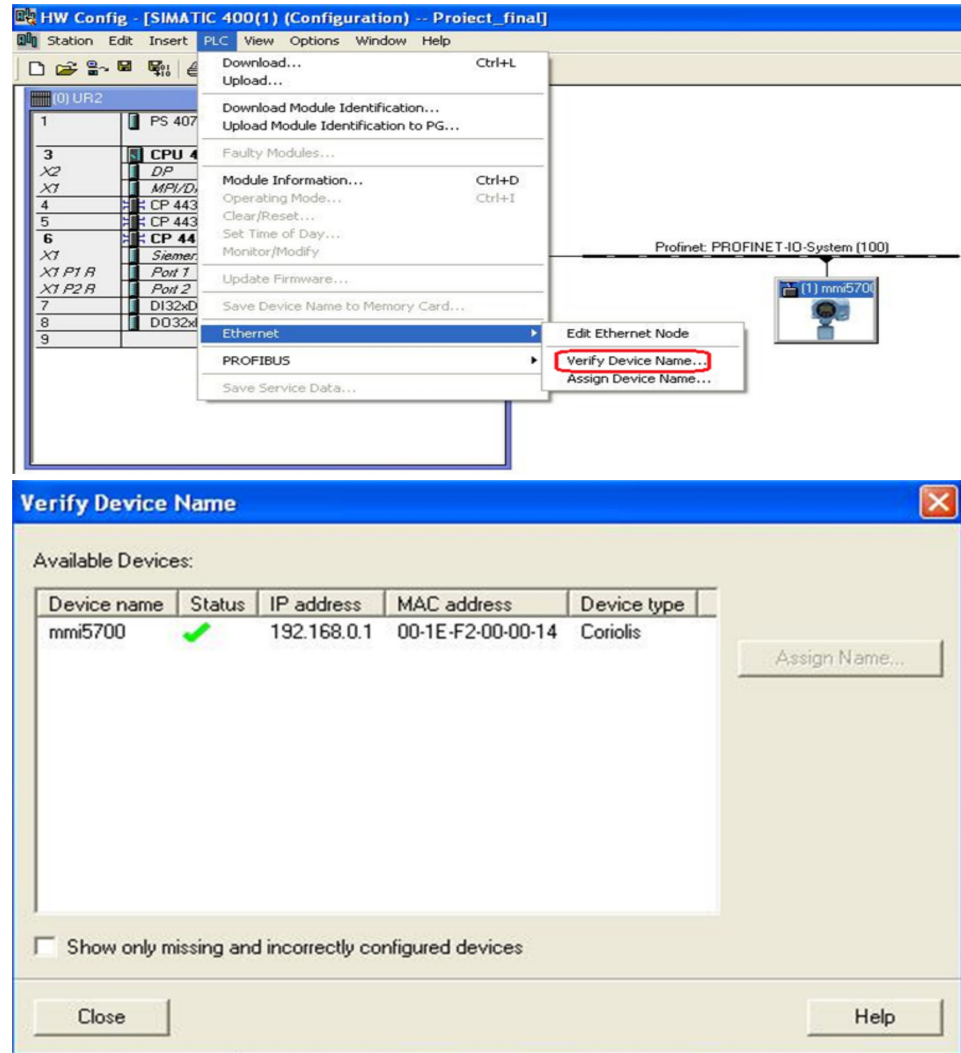

3.4 Verify communications

Procedure

1. Verify that the PLC shows no faults (red lights).
The most likely error will be a Bus Fault (BF LED is red), which means either the **Device Name**, the **IP address**, the **Input Slot**, or the **Output Slot** between the PLC and the Model 5700 Ethernet transmitter does not match.
2. To verify you are receiving data:
 - a) In the HW Config, click the Model 5700 Ethernet icon.
 - b) Right-click on the **Input Slot** and press **Monitor/Modify**.
 - c) Click the **I/O Display** box and the **Monitor** box to see the process variables updating.

Example

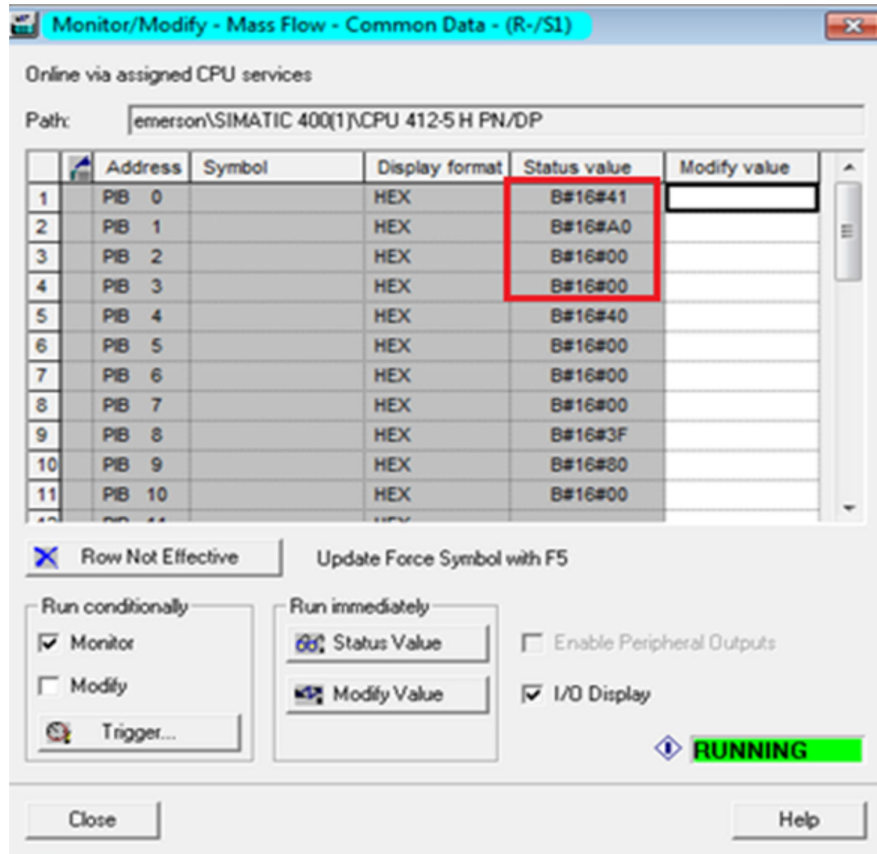

3. If the transmitter is still not communicating, from the transmitter display, choose **Menu** → **Configuration** → **Ethernet settings** → **Primary Protocol** → **Profinet** to verify that PROFINET is the configured primary protocol on the Model 5700 Ethernet transmitter.

3.5 Troubleshooting the PROFINET integration

3.5.1 Cannot download PROFINET into the PLC controller

Procedure

1. Choose **PLC** → **Ethernet** → **Edit Ethernet Node**.
2. Select **Browse**.
A list of network devices with MAC IDs is displayed.
3. Select the PROFINET controller and press **OK**.

Example

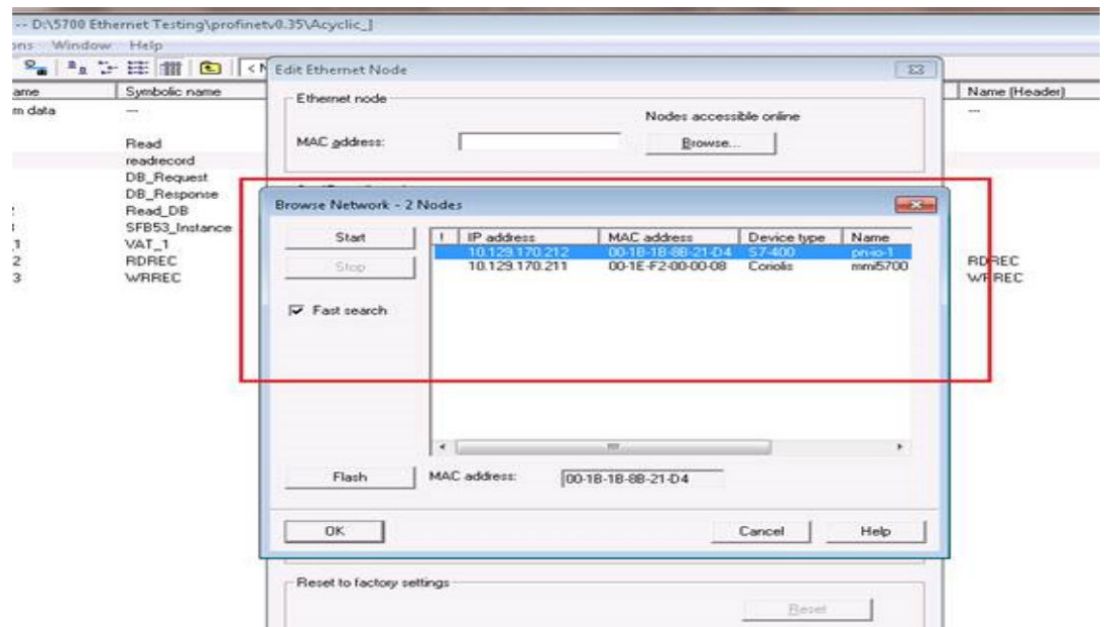

4 Configuring Siemens PLC read/write operation

Procedure

1. To insert the data blocks:
You will use the data blocks to configure the request and response parameters on the Siemens PLC.
 - a) From the **SIMATIC Manager** screen, select **Insert** → **S7 Block** → **Data Block**.

Example

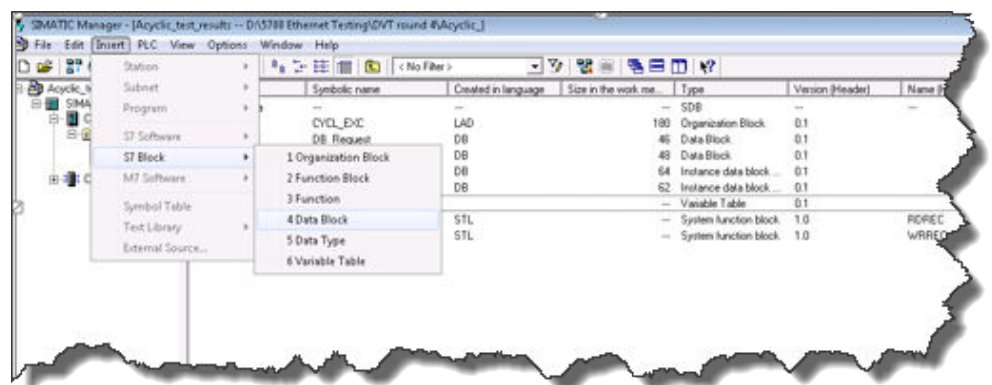

- b) From the **Properties** screen, enter the values as shown in the following example and select **OK**.

Example

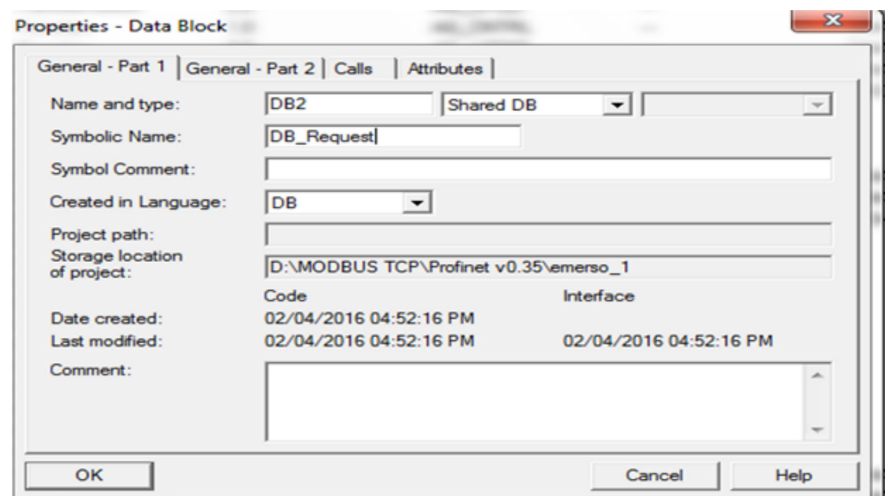

The first of two data blocks is created.

- c) From the **Properties** screen, enter the values as shown in the following example and select **OK**.

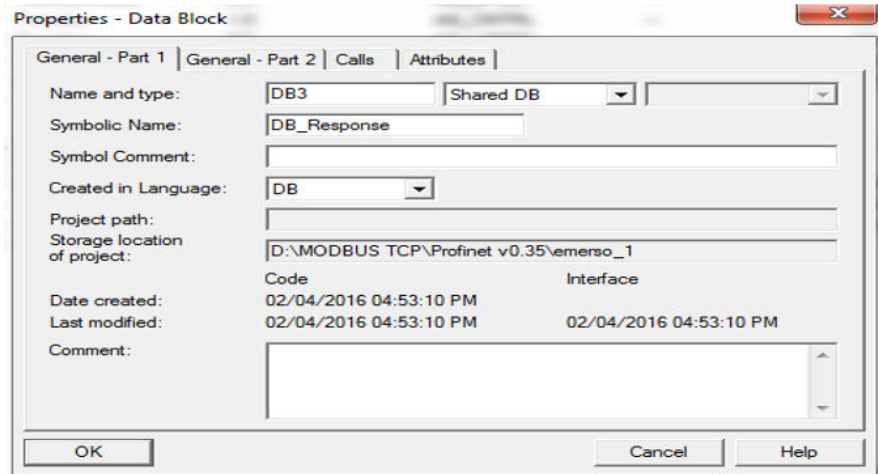

The second of two data blocks is created.

2. To copy the SFB52 and SFB53 data blocks to your project:
 - a) From the **SIMATIC Manager** screen, select **File** → **Open** and select the **Library** tab.
 - b) Select **Standard Library** and press **OK**.

Example

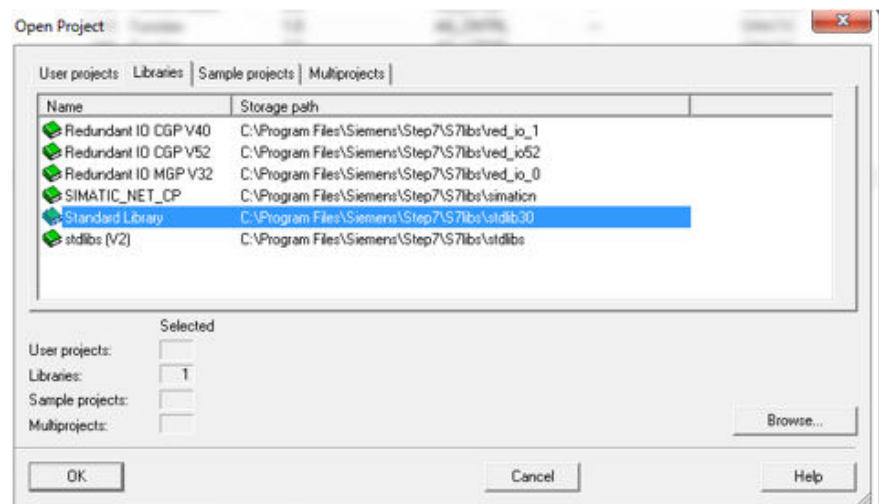

The pre-defined library opens.

- c) From the **Standard Library** tree view, select **System Function Blocks** → **Blocks**.
 - d) From the right panel, select **SFB52** and **SFB53**, and select **Copy**.

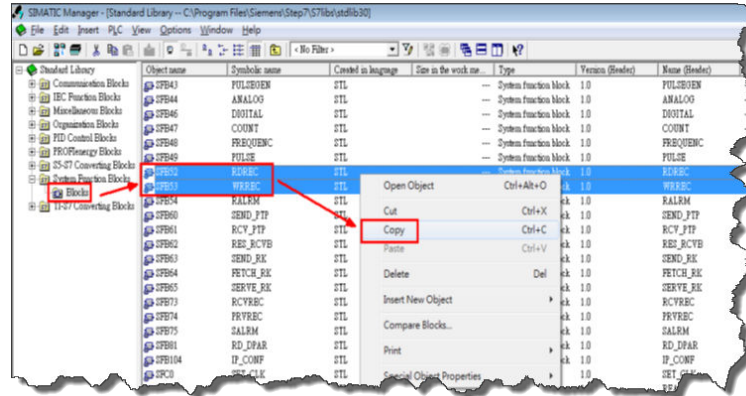

SFB52 and SFB53 are copied to your **Projects** folder under **CPU → S7 Program → Blocks**.

3. To add the SFB52 and SFB53 DB instances:
 - a) To create the data blocks, choose **Insert → S7 Block → Data Block**.
 - b) Enter the values as shown in the following example and select **OK**.

Example

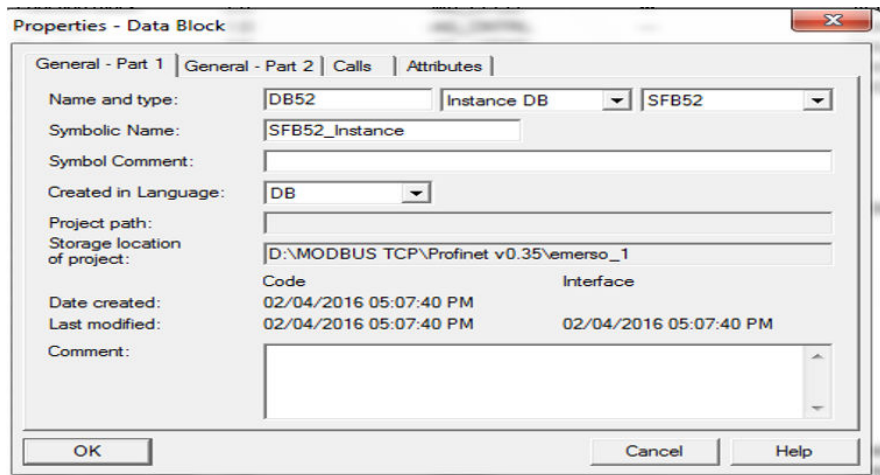

The first of the two data block DB instances is added.

- c) Enter the values as shown in the following example and select **OK**.

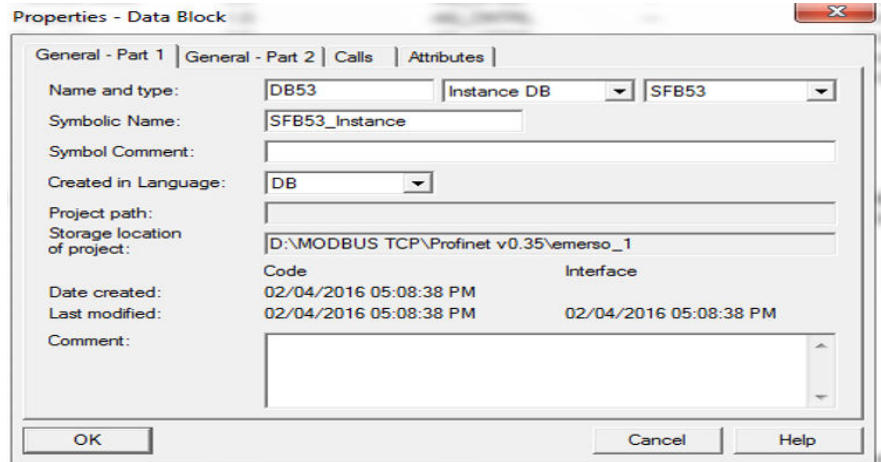

The second of the two data block DB instances is added. The SIMATIC Manager displays the entries.

Object name	Symbolic name	Created in language	Size in the work me...	Type	Version (Header)
System data	SDB	...
OB1	CYCL_EXC	LAD	180	Organization Block	0.1
DB2	DB_Request	DB	46	Data Block	0.1
DB3	DB_response	DB	48	Data Block	0.1
DB52	SFB52_Instance	DB	64	Instance data block ...	0.1
DB53	SFB53_Instance	DB	62	Instance data block ...	0.1
VAT_1	VAT_1	Variable Table	0.1
SFB52	RDREC	STL	...	System function block	1.0
SFB53	WRREC	STL	...	System function block	1.0

- To configure the DB2 Request data block, double-click **DB2 Request** and enter the values as shown in the following example.

Example

Address	Name	Type	Initial value	Comment
0.0		STRUCT		
+0.0	Word2	WORD	W#16#0	
+2.0	Word3	WORD	W#16#0	
+4.0	Word4	WORD	W#16#0	
+6.0	Word5	WORD	W#16#0	
=8.0		END_STRUCT		

- To configure the DB3 Response data block, double-click **DB3 Response** and enter the values as shown in the following example.

Example

Address	Name	Type	Initial value	Comment
0.0		STRUCT		
+0.0	ReadWord1	REAL	0.000000e+000	
+4.0	ReadWord2	REAL	0.000000e+000	
+8.0	ReadWord3	REAL	0.000000e+000	
=12.0		END_STRUCT		

- To program acyclic read:
 - Double-click **OB1**.

Example

Object name	Symbolic name	Created in language	Size in the work me...	Type	Version (Header)
System data	SDB	...
OB1	CYCL_EXC	LAD	174	Organization Block	0.1
DB2	DB_Request	DB	46	Data Block	0.1
DB53	SFB53_Instance	DB	62	Instance data block ...	0.1
VAT_1	VAT_1	Variable Table	0.1
SFB52	RDREC	STL	...	System function block	1.0
SFB53	WRREC	STL	...	System function block	1.0

b) Choose **Insert** → **Network**.

Example

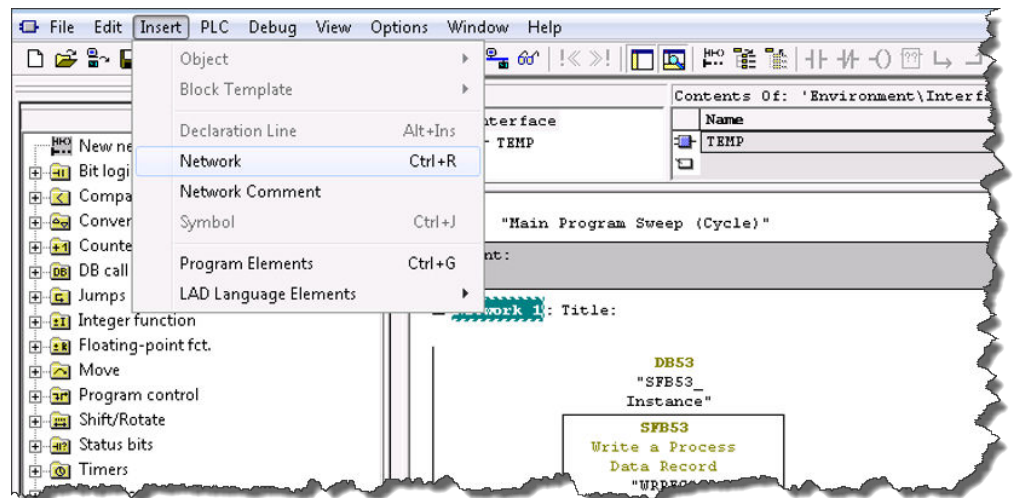

c) To configure the input and output parameters, from **SFB blocks**, drag **SFB52** to **Network**.

Example

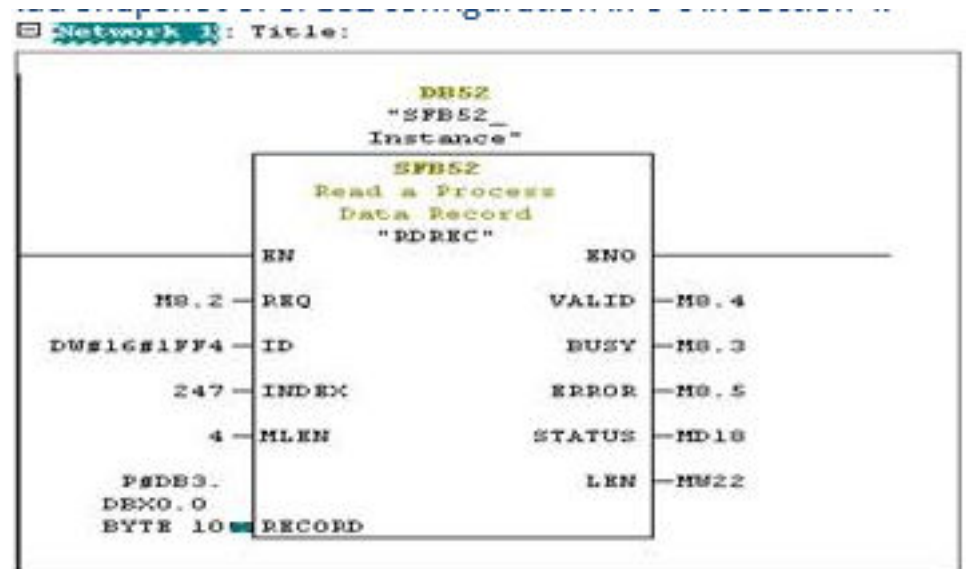

Parameter	Description
REQ	The Read request is sent to the Model 5700 using bit memory M8.2. You have the following options: <ul style="list-style-type: none"> • 1 (true) starts the read request. You must end the request. • 0 (false) ends the request. Reset Bit logic is used to reset M8.2.
VALID	Bit memory M8.4 indicates whether a new data record was received and valid.
BUSY	Bit memory M8.3 indicates whether the read process has terminated or not.
ERROR	Bit memory M8.5 indicates whether an error has occurred while processing the function.
STATUS	The double-word bit memory MD18 contains an error code. For error descriptions, see <i>Help on system functions / function blocks</i> .
ID	Displays the PN-IO diagnostic address (for example, "8180" = 1FF4 hex). This address is used for PROFINET acyclic read/write to the Model 5700E station to perform pre-defined diagnoses.
INDEX	Displays the data record number (247 – starting Modbus register for mass flow). For the Model 5700, the starting address is 1.
MLEN	The maximum length in bytes of data record information to be fetched.
RECORD	The destination area for the read data record. For DB3 in this example, the starting address is 0 and the address length is two bytes.

- d) Read the acyclic parameters displayed in the **Actual value** field.

Example

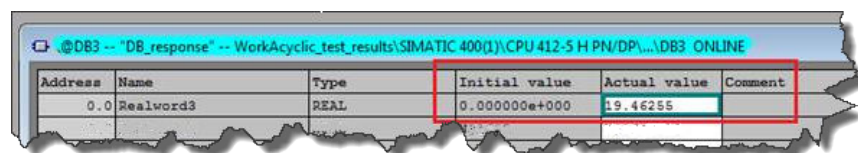

7. To program acyclic write, choose **S7 Program** → **Blocks** and double-click **OB1**.
The OB1 block is a Program Cycle Organization Block. The S7 CPU operating system executes OB1 periodically. When OB1 has been executed, the operating system restarts it. Cyclic execution of OB1 is started after the start-up has been completed.
- To edit the program, select **OB1**.
 - Choose **Insert** → **Network**.

- c) From **SFB blocks**, drag **SFB53** to **Network and** and configure the input and output as shown in the following example.

Example

Network 2: Title:

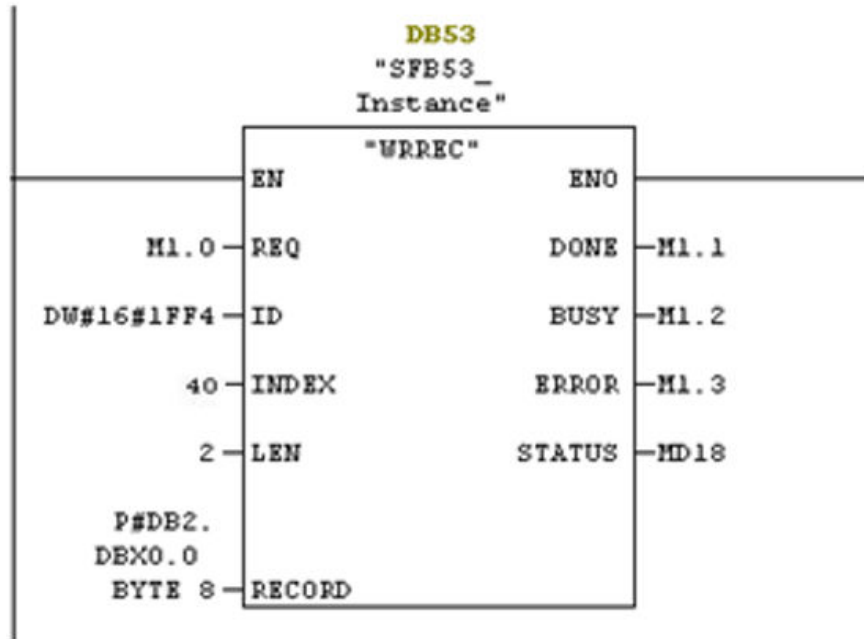

8. To create a variable table:

Use the variable table to modify and monitor the connected PLC variables and memory content.

- a) From the **SIMATIC Manager** screen, choose **Insert** → **S7 Block** → **Variable Table**.
b) Enter the values as shown in the following examples and save your changes.

Example

VAT_ACYCLIC -- @Project_finalSIMATIC 400(1)CPU 412-2 DP/S7 Program(1) ONLINE					
	Address	Symbol	Display format	Status value	Modify value
1	M 1.0		BOOL	true	true
2	DB2.DBW 0	"DB_Request" Word1	HEX	VW#16#005B	VW#16#005B
3					
4					
5					

The write request is sent to the Model 5700 using bit memory M1.0.

- c) To start the read request, enter **1** (true) in the **Modify value** field, right-click, and press **Modify**.
d) To end the request, enter **0** (false) in the **Modify value** field, right-click, and press **Modify**.
9. To download a project to PLC:

- a) From the **SIMATIC Manager** screen, select the **Download to Module** icon.
The configuration is downloaded to your CPU.
- b) After the project downloads, open the vat table and make the corresponding M 1.0, 8.2 bits high for read and read/write.
The read request is sent to the Model 5700 using bit memory M8.2. The write request is sent to the Model 5700 using bit memory M1.0.
- c) Go online to read and write acyclic data into the Model 5700 device module.

A Input and output slots

A.1 Input slots

Empty

Use the Empty Input slot when no input data is required. Typically for an Ethernet mass flow meter, the Empty Input slot is unused because this meter is a measuring device.

Table A-1: Common input data

Assembly Dword index	Name		Data type
0	Mass Flow		REAL
1	Temperature		REAL
2	Density		REAL
3	Drive Gain		REAL
4	Totalizer 1 (default = Mass Total)		REAL
5	Inventory 1 (default = Mass Inventory)		REAL
6	Status		DWORD
	Severity (bits 0-15)	<ul style="list-style-type: none"> • Bit #0 = Immediate Failure • Bit #1 = Last Measure Value Failure • Bit #2 = Function Check • Bit #3 = Out of Specification • Bit #4 = Maintenance Required 	
	Counter/Heartbeat (bits 16-32)	The PLC will display the counter/heartbeat as a signed INT, therefore the counter can be negative.	

Table A-1: Common input data (continued)

Assembly Dword index	Name		Data type
7	Alert detail	<ul style="list-style-type: none"> • Bit #0 = Electronics Failure • Bit #1 = Sensor Failed • Bit #2 = Configuration Error • Bit #3 = Core Low Power • Bit #4 = Security Breach • Bit #5 = Sensor-Transmitter Communication Error • Bit #6 = Tube Not Full • Bit #7 = Extreme Primary Purpose Variable • Bit #8 = Reserved • Bit #9 = Flowmeter Initializing • Bit #10 = Function Check in Progress • Bit #11 = Sensor Being Simulated • Bit #12 = Output Fixed • Bit #13 = Drive Over Range • Bit #14 = Process Aberration • Bit #15 = Discrete Event X Active • Bit #16 = Output Saturated • Bit #17 = Function Check Failed • Bit #18 = Web Server Passwords have not been changed 	DWORD
8	Echo Output Data Discrete Actions		DWORD

Table A-2: Liquid volume flow

Assembly Dword index	Name	Data type
0-8	Common input data	See Table A-1
9	Volume Flow	REAL
10	Totalizer 2 (default = Volume Total)	REAL
11	Inventory 2 (default = Volume Inventory)	REAL

Table A-3: Gas volume flow

Assembly Dword index	Name	Data type
0-8	Common input data	See Table A-1
9	Gas Volume Flow	REAL
10	Totalizer 4 (default = Gas Volume Total)	REAL
11	Inventory 4 (default = Gas Volume Inventory)	REAL

Table A-4: API referral

Assembly Dword index	Name	Data type
0-8	Common input data	See Table A-1
9	Volume Flow	REAL
10	Totalizer 2 (default = Volume Total)	REAL
11	Inventory 2 (default = Volume Inventory)	REAL
12	Corrected Density	REAL
13	Corrected Vol Flow	REAL
14	Totalizer 3 (default = Corrected Vol Total)	REAL
15	Inventory 3 (default = Corrected Vol Inv)	REAL
16	Avg Density	REAL
17	Avg Temperature	REAL
18	CTL	REAL

Table A-5: Concentration measurement

Assembly Dword index	Name	Data type
0-8	Common input data	See Table A-1
9	Volume Flow	REAL
10	Totalizer 2 (default = Volume Total)	REAL
11	Inventory 2 (default = Volume Inventory)	REAL
12	Density at Reference	REAL
13	Std Vol Flow Rate	REAL
14	Totalizer 5 (default = Std Vol Total)	REAL
15	Inventory 5 (default = Std Vol Inv)	REAL
16	Net Mass Flow Rate	REAL
17	Totalizer 6 (default = Net Mass Total)	REAL
18	Inventory 6 (default = Net Mass Inv)	REAL

Table A-5: Concentration measurement (continued)

Assembly Dword index	Name	Data type
19	Net Vol Flow Rate	REAL
20	Totalizer 7 (default = Net Vol Flow Total)	REAL
21	Inventory 7 (default = Net Vol Flow Inv)	REAL
22	Concentration	REAL
23	Density - Fixed SG Units	REAL
24	Density - Special Density Units	REAL

Table A-6: Batcher

Assembly Dword index	Name	Data type
0-8	Common input data	See Table A-2
9-11	Liquid Volume	
12	Batch Total	REAL
13	Overshoot Compensation Value (Reg 1457)	REAL
14	Batch Fill Time	REAL
15	Fill status and diagnostics <ul style="list-style-type: none"> • Bit #0 - Primary Fill in progress (reg 2495 bit 0) • Bit #1 - Primary AOC training (reg 2495 bit 9) • Bit #2 = Primary Valve (reg 2495 bit 5) • Bit #3 = Secondary Status (Open/Closed) • Bit #4 = Pump Status (On/Off) • Bit #5 = Ready to Batch (1-Ready) • Bit #6 - Fill Start Not Okay (reg 2496 bit 0) • Bit #7 - AOC Flow Rate Too High (reg 2496 bit 1) • Bit #8 - Maximum Fill Time Exceeded (reg 2496 bit 2) • Bit #9 - Slug Flow (reg 2496 bit 3) • Bit #10 - Tube Not Full (reg 2496 bit 4) • Bit #11 - Drive Overrange (reg 2496 bit 5) • Bit #12 - Critical Sensor Failure (reg 2496 bit 6) • Bit #13 - Critical Transmitter Failure (reg 2496 bit 7) • Bit #14 - Density Out of Limits (reg 2496 bit 8) • Bit #15 - Temperature Out of Limits (reg 2496 bit 9) • Bit #16 - Bit #31 for future expansion 	DWORD
16	Batch Target	REAL
17	Batch Preset	DINT

Table A-7: Small input configurable data set

Assembly Dword index	Name	Data type
0-8	Common input data	See Table A-1
9-16	8 configurable slots	REAL *8

Table A-8: Medium input configurable data set

Assembly Dword index	Name	Data type
0-8	Common input data	See Table A-1
9-24	16 configurable slots	REAL *16

Table A-9: Large input configurable data set

Assembly Dword index	Name	Data type
0-8	Common input data	See Table A-1
9-40	32 configurable slots	REAL *32

Table A-10: Advanced Phase Measurement (APM) - liquid

Assembly Dword index	Name	Data type
0-8	Common input data	See Table A-1
9	Volume Flow	REAL
10	Totalizer 2 (default = Volume Total)	REAL
11	Inventory 2 (default = Volume Inventory)	REAL
12	Gas Void Fraction	REAL
13	Contract Total 1	REAL
14	Contract Total 2	REAL
15	Contract Total 3	REAL
16	Contract Total 4	REAL
17	Net Oil Flow @ Line	REAL
18	Net Water Flow @ Line	REAL
19	Watercut @ Line	REAL
20	Net Oil Total @ Line	REAL
21	Net Water Total @ Line	REAL
22	Density Oil @ Line	REAL
23	Net Oil Flow @ Ref	REAL

Table A-10: Advanced Phase Measurement (APM) – liquid (continued)

Assembly Dword index	Name	Data type
24	Net Water Flow @ Ref	REAL
25	Watercut @ Ref	REAL
26	Net Oil Total @ Ref	REAL
27	Net Water Total @ Ref	REAL

Table A-11: Advanced Phase Measurement (APM) – gas volume

Assembly Dword index	Name	Data type
0-8	Common input data	See Table A-1
9	Gas Volume Flow	REAL
10	Totalizer 4 (default = Gas Volume Total)	REAL
11	Inventory 4 (default = Gas Volume Inventory)	REAL
12	Contract Total 1	REAL
13	Contract Total 2	REAL
14	Contract Total 3	REAL
15	Contract Total 4	REAL
16	Total time mist detected	DINT
17	APM Status <ul style="list-style-type: none"> • Bit #0 – TMR Algorithm Active (reg 433 bit 12) • Bit #1 – Bit #15 currently not defined • Bit #16 – Bit #31 for future expansion 	DWORD
18	Liquid Mass Flow Estimate	REAL
19	Watercut @ Ref	REAL

Table A-12: Advanced Phase Measurement (APM) –Wet Gas Measurement

Assembly Dword index	Name	Data type
0-8	Common input data	See Table A-1
9	Gas Volume Flow	REAL
10	Totalizer 4 (default = Gas Volume Total)	REAL
11	Inventory 4 (default = Gas Volume Inventory)	REAL
12	Gas Void Fraction	REAL
13	Totalizer 2 (default = Volume Total)	REAL
14	Inventory 2 (default = Volume Inventory)	REAL
15	Contract Total 1	REAL

Table A-12: Advanced Phase Measurement (APM) -Wet Gas Measurement (continued)

Assembly Dword index	Name	Data type
16	Contract Total 2	REAL
17	Contract Total 3	REAL
18	Contract Total 4	REAL
19	Total time mist detected	DINT
20	APM Status <ul style="list-style-type: none"> • Bit #0 – TMR Algorithm Active (reg 433 bit 12) • Bit #1 – Bit #15 undefined • Bit #16 – Bit #31 for future expansion 	DWORD
21	Liquid Mass Flow Estimate	REAL
22	Watercut @ Ref	REAL
23	Gas Mass Flow (Reg 2008)	REAL
24	Liquid Volume Flow (Reg 2261)	REAL
25	Gas to Liquid Ratio (Reg 2255)	REAL
26	Gas to Oil Ratio (Reg 2263)	REAL
27	Net Oil Flow @ Ref	REAL
28	Net Water Flow @ Ref	REAL
29	Net Oil Total @ Ref	REAL
30	Net Water Total @ Ref	REAL

Table A-13: Device Status

Assembly Dword index	Name	Data type
0	Status & Diagnosis <ul style="list-style-type: none"> • Bit #0 – Smart Meter Verification Running • Bit #1 – Smart Meter Verification Passed • Bit #2 – Smart Meter Verification Failed • Bit #3 – Smart Meter Verification Aborted • Bit #4 – Bit #31 for future expansion 	DWORD
1	LPO	REAL
2	RPO	REAL
3	Live Zero	REAL
4	Tube Frequency	REAL
5	Core Temperature	REAL
6	Case Temperature	REAL
7	Core In Volts	REAL

Table A-13: Device Status (continued)

Assembly Dword index	Name	Data type
8	Flow Verification Zero	REAL
9	Result 1 (LPO Normalized Stiffness Reg 5782)	REAL
10	Result 1 (RPO Normalized Stiffness Reg 5784)	REAL
11	Result 3 - Future Use	REAL
12	Result 4 - Future Use	REAL
13	Result 5 - Future Use	REAL
14	Result 6 - Future Use	REAL
15	Data 1 - (Confidence Interval LPO Reg 6360)	REAL
16	Data 2 - (Confidence Interval RPO Reg 6362)	REAL
17	Data 3 - (LPO Std. Dev. Reg 6356)	REAL
18	Data 4 - (RPO Std. Dev. Reg 6358)	REAL
19	Data 5 - (LPO Meter Factor Reg 6371)	REAL
20	Data 6 - (RPO Meter Factor Reg 6373)	REAL
21	Data 7 - Future Use	REAL
22	Data 8 - Future Use	REAL
23	Data 9 - Future Use	REAL
24	Smart Meter Verification Run Number (Reg 5826)	DINT
25	Smart Meter Verification Progress (Reg 3020)	DINT
26	Code 1 (Abort Code Reg 3002)	DINT
27	Code 2 - Future Use	DINT
28	Code 3 - Future Use	DINT

A.2 Output slots

Common output data is required for every output assembly in order to access 5700 functions. Depending on the application, not all functions may be used.

Empty

Use the Empty Input slot when no output data is required. No output data is a typical application and is the default.

Table A-14: Common output data — Discrete actions only

Assembly Dword index	Name	Data type
0	Discrete Actions: <ul style="list-style-type: none"> • Bit #0 – Start Sensor Zero (trigger start with a 1, no abort) • Bit #1 – Reset All Process Totals (same as setting bits 2-8) • Bit #2 – Reset Totalizer 1 (Mass Total by default) • Bit #3 – Reset Totalizer 2 (Volume Total by default) • Bit #4 – Reset Totalizer 3 (PM Ref Vol Total by default) • Bit #5 – Reset Totalizer 4 (GSV Total by default) • Bit #6 – Reset Totalizer 5 (CM Ref Vol Total by default) • Bit #7 – Reset Totalizer 6 (CM Net Mass Total by default) • Bit #8 – Reset Totalizer 7 (CM Net Vol Total by default) • Bit #9 – Start All Totals (trigger start with a 1) • Bit #10 – Stop All Totals (trigger stop with a 1) If both start and stop =1, then totals are stopped • Bit #11 – Start Smart Meter Verification (Continue Measuring Mode only) Trigger start with a 1, no abort • Bit #12 – Reset all Inventory Totals • Bit #13 – Bit #31 for future expansion 	DWORD

Table A-15: External process data

Assembly Dword index	Name	Data type
0	Common output data	See Table A-14
1	External Pressure	REAL
2	External Temperature	REAL

Table A-16: Batcher

Assembly Dword index	Name	Data type
0	Common output data	See Table A-14
1	Batch Target	REAL
2	Batcher Control - Discrete Actions <ul style="list-style-type: none"> • Bit #0 - Reserved • Bit #1 - Start Fill • Bit #2 - End Fill • Bit #3 - Pause Fill • Bit #4 - Resume Fill • Bit #5 - Reserved • Bit #6 - Start Training • Bit #7 - Save AOC Calibration • Bit #8 - Reset Batch Total • Bit #9 - Print Batch Ticket • Bit #10 - Reset Preset 1 Inventory • Bit #11 - Reset Preset 2 Inventory • Bit #12 - Reset Preset 3 Inventory • Bit #13 - Reset Preset 4 Inventory • Bit #14 - Reset Preset 5 Inventory • Bit #15 - Reset Preset 6 Inventory • Bit #16 - Inhibit Totalizer • Bit #17 - Inhibit Flow • Bit #18 - Inhibit Batch • Bit #19 - Bit #31 for future expansion 	DWORD
3	Maximum Batch Time (Reg 1305)	REAL
4	Batch Preset	DINT

Table A-17: Batcher and external process data

Assembly Dword index	Name	Data type
0-2	External process data	See Table A-15
3	Batch Target	REAL

Table A-17: Batcher and external process data (continued)

Assembly Dword index	Name	Data type
4	Batcher Control – Discrete Actions <ul style="list-style-type: none"> • Bit #0 – Reserved • Bit #1 – Start Fill • Bit #2 – End Fill • Bit #2 – Pause Fill • Bit #4 – Resume Fill • Bit #5 – Reserved • Bit #6 – Start Training • Bit #7 – Save AOC Calibration • Bit #8 – Reset Batch Total • Bit #9 – Print Batch Ticket • Bit #10 – Reset Preset 1 Inventory • Bit #11 – Reset Preset 2 Inventory • Bit #12 – Reset Preset 3 Inventory • Bit #13 – Reset Preset 4 Inventory • Bit #14 – Reset Preset 5 Inventory • Bit #15 – Reset Preset 6 Inventory • Bit #16 – Inhibit Totalizer • Bit #17 – Inhibit Flow • Bit #18 – Inhibit Batch • Bit #19 – Bit #31 for future expansion 	DWORD
5	Maximum Batch Time (Reg 1305)	REAL
6	Batch Preset	DINT

Table A-18: Output configurable data

Assembly Dword index	Name	Data type
0	Common output data	DWORD
1	Configurable Slot 1 (Register)	DWORD
2	Configurable Slot 2 (Register)	DWORD
3	Configurable Slot 3 (Register)	DWORD
4	Configurable Slot 4 (Register)	DWORD
5	Configurable Slot 5 (Register)	DWORD
6	Configurable Slot 6 (Register)	DWORD
7	Configurable Slot 7 (Register)	DWORD

Table A-18: Output configurable data (continued)

Assembly Dword index	Name	Data type
8	Configurable Slot 8 (Register)	DWORD
9	Configurable Slot 9 (Coil)	DWORD
10	Configurable Slot 10 (Coil)	DWORD
11	Configurable Slot 11 (Coil)	DWORD
12	Configurable Slot 12 (Coil)	DWORD

Table A-19: Advanced Phase Measurement (APM)

Assembly Dword index	Name	Data type
0	Common output data	See Table A-14
1	External Pressure	REAL
2	External Temperature	REAL
3	External Water Cut	REAL



MMI-20029785
Rev. AC
2024

For more information: [Emerson.com/global](https://www.emerson.com/global)

©2024 Micro Motion, Inc. All rights reserved.

The Emerson logo is a trademark and service mark of Emerson Electric Co. Micro Motion, ELITE, ProLink, MVD and MVD Direct Connect marks are marks of one of the Emerson Automation Solutions family of companies. All other marks are property of their respective owners.

MICRO MOTION™

