

# Rosemount™ 6888Xi

Advanced Electronics for Zirconium Oxide  
Flue Gas O<sub>2</sub> Probes





# Essential instructions

## Read this page before proceeding

Emerson designs, manufactures, and tests its products to meet many national and international standards. Because these instruments are sophisticated technical products, you **MUST** properly install, use, and maintain them to ensure they continue to operate within their normal specifications. The following instructions **MUST** be adhered to and integrated into your safety program when installing, using, and maintaining Rosemount products. Failure to follow the proper instructions may cause any one of the following situations to occur: loss of life; personal injury; property damage; damage to this instrument; and warranty invalidation.

- Read all instructions prior to installing, operating, and servicing the product.
- If you do not understand any of the instructions, contact your Emerson representative for clarification.
- Follow all warnings, cautions, and instructions marked on and supplied with the product.
- Inform and educate your personnel in the proper installation, operation, and maintenance of the product.
- Install your equipment as specified in the installation instructions of the appropriate Manual and per applicable local and national codes. Connect all products to the proper electrical and pressure sources.
- To ensure proper performance, use qualified personnel to install, operate, update, program, and maintain the product.
- When replacement parts are required, ensure that qualified people use replacement parts specified by Emerson. Unauthorized parts and procedures can affect the product's performance, place the safe operation of your process at risk, and **VOID YOUR WARRANTY**. Look-alike substitutions may result in fire, electrical hazards, or improper operation.
- Ensure that all equipment doors are closed and protective covers are in place, except when maintenance is being performed by qualified persons, to prevent electrical shock and personal injury.

The information contained in this document is subject to change without notice.

### NOTES

**The 375 Field Communicator must be upgraded to System Software 2.0 with Graphic License for operation with the Rosemount 6888Xi Electronics. The Asset Management Solutions (AMS) software must be upgraded to AMS 8.0 or above. Contact Emerson's Global Service Center (GSC) at 1-800-833-8314 to upgrade the 375 Field Communicator software to System Software 2.0 with Graphic License.**



# Table of contents

Essential instructions.....	I
<b>Section 1: Introduction</b>	
1.1 Preface .....	1
1.2 Definitions .....	1
1.3 Symbols.....	2
1.4 Overview .....	2
1.5 Technical support hotline .....	2
<b>Section 2: Description and specifications</b>	
2.1 Component checklist .....	3
2.2 System overview .....	3
2.2.1 Power supply - current loop wiring .....	3
2.2.2 System configurations.....	4
2.2.3 Automatic calibration.....	5
2.2.4 Communication options .....	6
2.3 Specifications .....	8
<b>Section 3: Installation</b>	
3.1 System considerations .....	12
3.2 Mechanical installation.....	13
3.3 Electrical installation .....	15
<b>Section 4: Configuration, start-up, and operation</b>	
4.1 Overview .....	25
4.2 Start-up .....	25
4.2.1 Configuration.....	26
4.2.2 Operation.....	26
4.2.3 Start-up display .....	26
4.2.4 Error conditions.....	27
4.2.5 Keypad .....	27
4.2.6 Password protection. ....	34
4.3 Optional advanced features .....	34
4.3.1 Extended temperature .....	35
4.3.2 Stoichiometer.....	35
4.3.3 Programmable reference .....	36
4.3.4 Plugged diffusion element diagnostic .....	36
4.4 System parameter descriptions.....	40
4.5 Probe parameter descriptions. ....	40
4.6 Operation via HART/Asset Management Solutions (AMS) software .....	40
4.6.1 Field Communicator signal line connections.....	48
4.6.2 Field Communicator menu trees.....	48

4.7	Parameter setup.....	48
4.7.1	Test gas values.....	48
4.7.2	Test gas times.....	53
4.7.3	Output tracking during calibration .....	54
4.7.4	Tolerance check.....	54
4.7.5	Alarm relay output configuration. ....	55
4.7.6	Analog output configuration .....	57
4.7.7	Autocalibration.....	58
4.7.8	Calibration recommended setup.....	58
4.7.9	Calibration acknowledged setup. ....	59
4.7.10	Plug diffuser diagnostic. ....	59
4.7.11	Low temperature set point .....	61
4.8	Calibration - general .....	62
4.8.1	General.....	62
4.8.2	Calibration procedure .....	62
4.8.3	Calibration log.....	67
4.8.4	Reset calibration.....	67
4.9	D/A trim. ....	68

## Section 5: Troubleshooting

5.1	Overview of operating principles.....	71
5.2	General.....	72
5.2.1	Grounding.....	72
5.2.2	Electrical noise .....	72
5.2.3	Electrostatic discharge .....	72
5.3	Alarm indications .....	72
5.4	Identifying and correcting fault indications.....	73
5.5	Calibration passes, but still reads incorrectly .....	74
5.5.1	Probe passes calibration, O <sub>2</sub> still reads high .....	75
5.5.2	Probe passes calibration, O <sub>2</sub> still reads low .....	76
5.5.3	How do I detect a plugged diffuser? .....	76
5.5.4	Can I calibrate a badly plugged diffuser? .....	76

## Section 6: Maintenance and service

6.1	Overview .....	79
6.2	Maintenance intervals .....	79
6.3	Calibration.....	80
6.3.1	Automatic calibration.....	80
6.3.2	Manual calibration.....	80
6.4	Replacement parts .....	81
6.5	Rosemount 6888Xi components replacement.....	81
6.5.1	Input/output (IO) board replacement .....	81

6.5.2	AC relay board replacement .....	85
6.5.3	Power supply board replacement .....	87
6.5.4	Front panel replacement .....	88
6.5.5	DR board replacement .....	90

## Section 7: Replacement parts

7.1	Rosemount 6888Xi electronics .....	93
7.2	Calibration components.....	93

## Section 8: Optional accessories

8.1	HART handheld 475 Field Communicator .....	95
8.2	Asset Management Solutions (AMS) software .....	95
8.3	By-pass packages .....	95
8.4	Rosemount SPS 4001B Single Probe Autocalibration Sequencer .....	96
8.5	O <sub>2</sub> calibration gas. ....	97
8.6	OxyBalance Display and Averaging System .....	98

## Appendix A: Safety data

A.1	Safety instructions.....	99
-----	--------------------------	----

## Appendix B: Return of material

B.1	Returning Material.....	100
-----	-------------------------	-----

## Appendix C: Declaration of Conformity .....

## Appendix D: China RoHS table .....





# Section 1: Introduction

## 1.1 Preface

The purpose of this manual is to provide information concerning components, functions, installation and maintenance of the 6888Xi Electronics. Some sections may describe equipment not used in your configuration. The user should become thoroughly familiar with the operation of this module before operating it. Read this instruction manual completely.

## 1.2 Definitions

The following definitions apply to WARNINGS, CAUTIONS, and NOTES

### WARNING

Highlights an operation or maintenance procedure, practice, condition, statement, etc. If not strictly observed, could result in injury, death, or long-term health hazards of personnel.





### CAUTION

Highlights an operation or maintenance procedure, practice, condition, statement, etc. If not strictly observed, could result in damage to or destruction of equipment, or loss of effectiveness.

### NOTE

Highlights an essential operating procedure, condition, or statement.

## 1.3 Symbols

-  : EARTH (GROUND) TERMINAL
-  : PROTECTIVE CONDUCT OR TERMINAL
-  : RISK OF ELECTRICAL SHOCK
-  : WARNING: REFER TO INSTRUCTION MANUAL

## 1.4 Overview

The Rosemount 6888Xi is specifically designed to control a zirconium oxide probe for measuring oxygen, usually the O<sub>2</sub> remaining from a combustion process. Call the Rosemount Customer Support Center (CSC) to get recommendations for other oxygen probes.

Phone : +1 855 724 2628

The 6888Xi electronics has several main functions:

1. Heater Control - The electronics receives a type K thermocouple input from an O<sub>2</sub> probe and switches power on and off to the probe's heater in order to maintain a temperature setpoint of 736 °C.
2. Signal Conditioning - The electronics receives the raw millivolt signal from the O<sub>2</sub> sensing cell, then linearizes and amplifies the signal to provide a linear 4-20 mA output signal used for recording or as an input into a DCS system for control purposes.
3. Calibration - A bottled calibration gas of known value is typically flowed into the probe's sensor to verify that it is reading correctly. If the signal is out of calibration, the calibration gas is used to adjust the 4-20 mA output signal. During calibration the 6888Xi prompts the technician to flow two calibration gases into the probe and, with the calibration gases flowing, automatically adjusts the O<sub>2</sub> signal. With the addition of a Single Probe Sequencer (SPS), the 6888Xi Advanced Electronics can also switch the calibration gases on and off.
4. Diagnostics - Multiple alarms are available for display. The alarm displays are intended to assist a technician in locating where an instrument problem may reside.

The Rosemount 6888Xi Advanced Electronics has been verified to operate the following probes:

- Westinghouse 218 and World Class (115 V heater only)
- Rosemount Oxymitter and 6888
- Yokogawa

The Rosemount 6888Xi Advanced Electronics will not operate the following probes:

- World Class (44 V Heater)
- XSTREAM O<sub>2</sub> Probe (Transmitter, Integral Electronics)

## 1.5 Technical support hotline

For assistance with technical problems, please call the Customer Support Center (CSC).

Phone: +1 855 724 2638

In addition to the CSC, you may also contact Field Watch. Field Watch coordinates Emerson's field service throughout the U.S. and abroad.

Phone: 1-800-654-RSMT (1-800-654-7768)

e-mail: [gas.csc@emerson.com](mailto:gas.csc@emerson.com)

# Section 2: Description and specifications

## 2.1 Component checklist

A typical Rosemount O<sub>2</sub> Combustion Flue Gas Transmitter should contain the items shown in Figure 1-1. A complete Oxygen Analyzer system will include some or all of the equipment shown. However, this manual describes item 8 only. Record the part number, serial number, and order number for the Rosemount 6888Xi Advanced Electronics in the table located on the back cover of this manual.

Also, use the product matrix (Table 1-1) at the end of this section to compare your order number against your unit. The first part of the matrix defines the model. The last part defines the various options and features. Ensure the features and options specified by your order number are on or included with the unit.

## 2.2 System overview

### 2.2.1 Power supply - current loop wiring

This Manual is designed to supply details needed to install, start up, operate, and maintain the Rosemount 6888Xi Advanced Electronics. Signal conditioning electronics outputs a 4-20 mA signal representing an O<sub>2</sub> value. This information, plus additional details, can be accessed with the handheld HART Model 375/475 Field Communicator or Asset Management Solutions (AMS) software.

Figure 2-1. Typical System Package

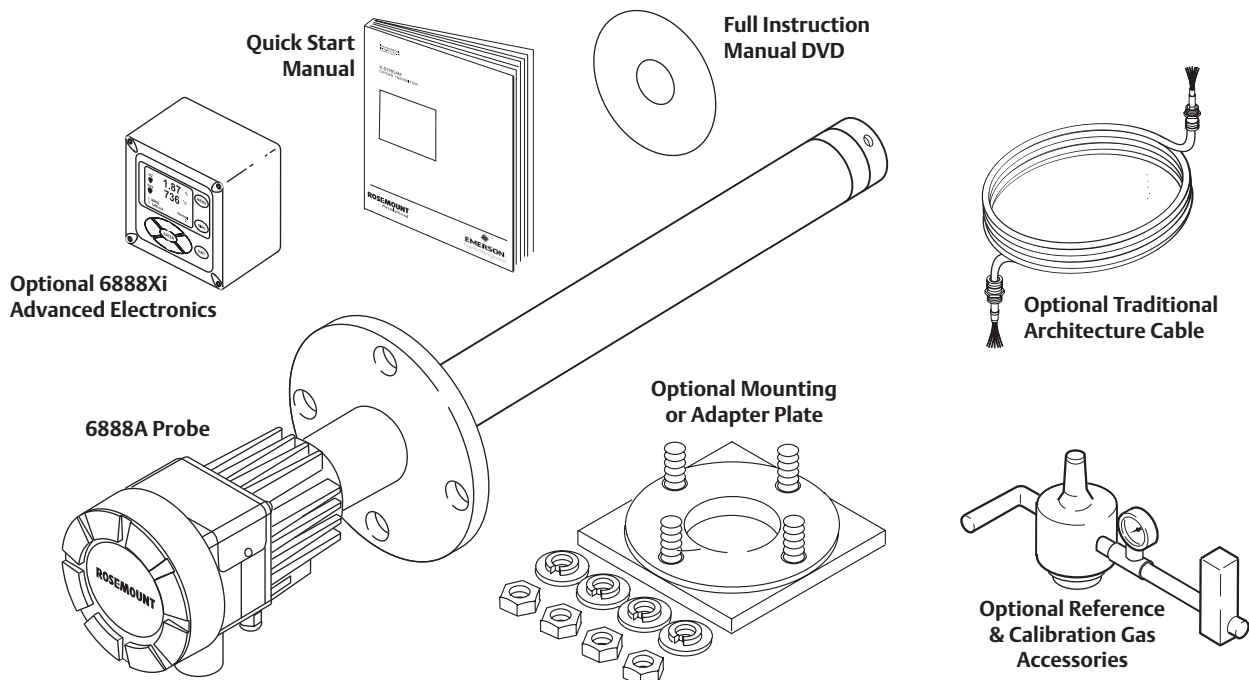

## 2.2.2 System configurations

### Integral Transmitter Electronics, HART and 6888Xi Communications

The Rosemount 6888Xi Advanced Electronics, Figure 1-2, provide a local display/keypad for setting up, calibrating, and displaying O<sub>2</sub>, and for diagnosing probe problems. The 6888Xi also offers additional features including a "Calibration Recommended" diagnostic, fully automatic calibration, optional flame safety interface (single probe version only), extended process temperature capability, stoichiometer, programmable reference, and plugged diffusor. These additional features will be discussed in other sections of this manual. The 6888Xi can be purchased to operate a single probe, or as a dual channel unit to run two probes.

**Figure 2-2. 6888A with Integral Transmitter Electronics and Optional 6888Xi Advanced Electronics**

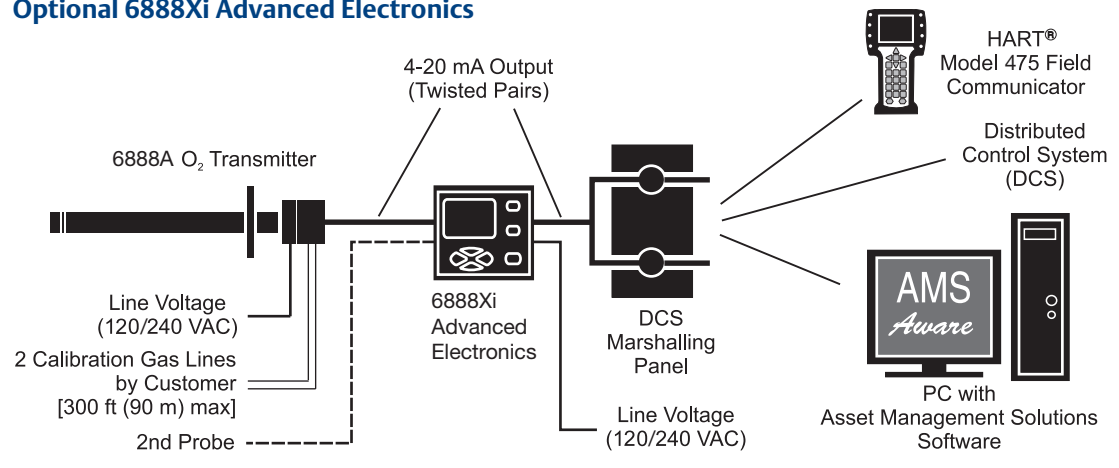

### Traditional Architecture, HART and 6888Xi Communications

Some customers prefer not to mount electronics onto the probe, so a "traditional architecture" version is offered. This probe sends raw millivolt signals via a 7-conductor cable to the 6888Xi electronics, Figure 1-3, which does all heater control and signal conditioning in addition to its display/keypad functions. The 6888Xi Advanced Electronics is offered to support direct replacement probes with 120 volt heaters.

**Figure 2-3. Direct Replacement Probe With Traditional Architecture Electronics**

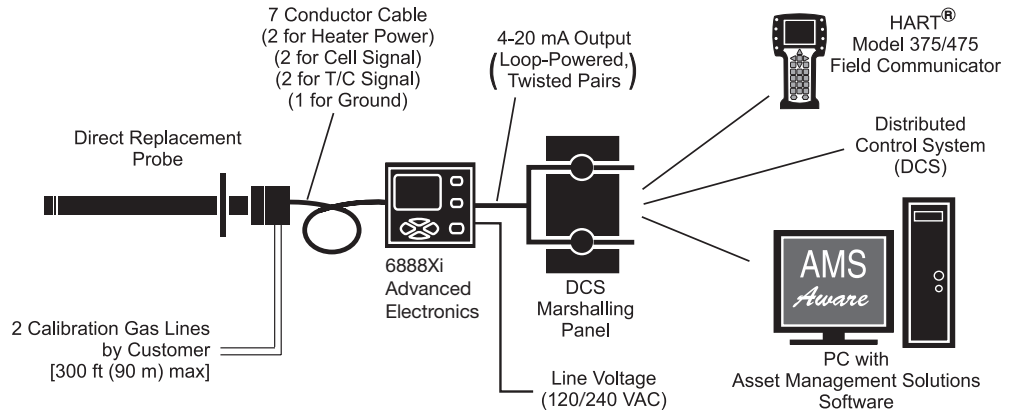

## 2.2.3 Automatic calibration

Calibrations consist of introducing bottled gases of known value into the probe so the electronics can make automatic adjustments to the O<sub>2</sub> readings to match the bottled gas value. 0.4% O<sub>2</sub> and 8% O<sub>2</sub> (balance nitrogen) gases are recommended. Never use nitrogen as a calibration gas.

Flowmeters (for calibration gases) and regulators and flowmeters (for reference air) are available as loose components, mounted into an optional manual calibration switching panel, or as a fully automatic calibration system, Figure 1-4, where calibration solenoids are switched from the 6888Xi Advanced Electronics. See the SPS 4001B Single Probe Autocalibration Sequencer Manual for additional details.

**Figure 2-4. 6888A Probe with Optional 6888Xi Advanced Electronics and Calibration Accessories**

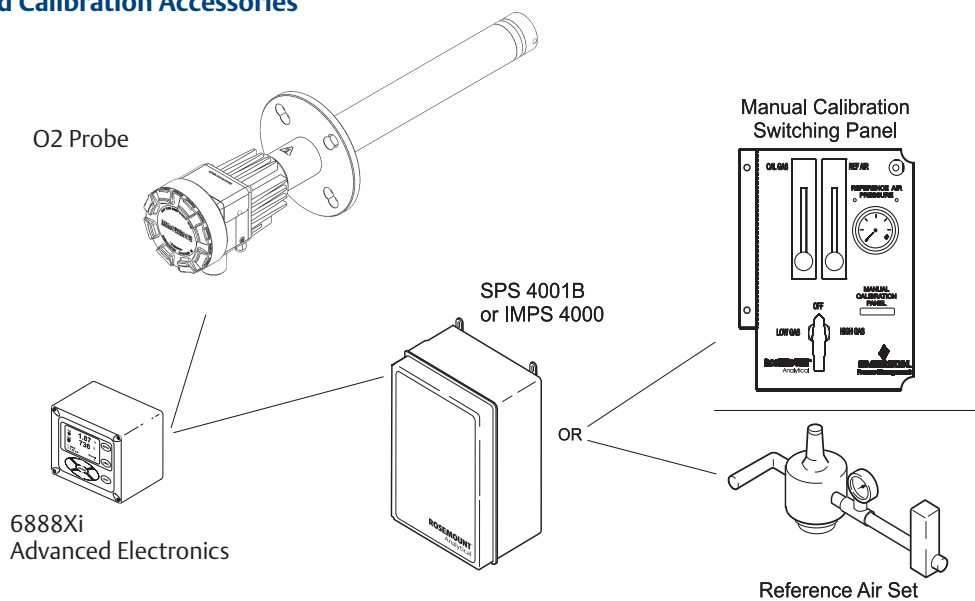

## 2.2.4 Communication options

### Data communications

An operator can configure and troubleshoot the O2 Probe system in one of two ways:

1. Using the 6888Xi Advanced Electronics keypad and display to access the following optional advanced features:
  - Probe configuration
  - Fully automatic calibration
  - Failure diagnostics
  - Flame safety interface
  - High temperature operation [above 700 °C (1292 °F) standard temperature].
  - Stoichiometer feature provides the ability to indicate O2 efficiency when the combustion process goes into reducing conditions (0% O2).
  - Programmable reference provides enhanced accuracy when measuring at or near O2 level (20.95% O2).
  - Plugged diffusor diagnostics
2. Using the HART Interface. The 6888Xi's 4-20 mA output line transmits an analog signal proportional to the oxygen level. The HART output is superimposed on the 4-20 mA output line. This information can be accessed through the following:
  - Rosemount Model 375/475 Field Communicator - The handheld communicator requires Device Description (DD) software specific to the 6888Xi. The DD software will be supplied with many Model 375/475 units but can also be programmed into existing units at most Emerson service offices. See Section 4, Startup and Operation, for additional information.
  - Personal Computer (PC) - The use of a personal computer requires AMS software available from Emerson.
  - Delta V and Ovation Distributed Control System (DCS) with AMS-inside capability.

#### NOTE

**The 375 Field Communicator must be upgraded to System Software 2.0 with Graphic License for operation with the 6888Xi. The AMS software must be upgraded to AMS 8.0 or above. Contact Emerson's Global Service Center (GSC) at 1-800-833-8314 to upgrade the 375 Field Communicator software to System Software 2.0 with Graphic License.**

- The 6888Xi can also transmit HART information wirelessly via a wireless THUM Adapter, Figure 1-5. The THUM Adapter threads into the 6888Xi conduit port and converts the 4-20 mA O<sub>2</sub> signal to a wireless protocol. All other HART information is also transmitted.

In addition to the wireless THUM Adapter, a hard-wire connection of the 4-20 mA signal to the DCS may be used at the same time. More detailed information regarding the application of the THUM Adapter is available in Product Data Sheet 00813-0100-4075.

**FIGURE 2-5. Wireless THUM Adapter with 6888Xi**



- The 6888Xi can be configured to communicate with a 6888A FOUNDATION Fieldbus probe. Refer to section 3.2.1 Configuration to set up for FOUNDATION Fieldbus communications.

### Optional OxyBalance Display and Averaging System

Receives up to eight 4-20 mA signals from individual 6888Xi units. Trends individual outputs and calculates four programmable averages as additional 4-20 mA outputs. OxyBalance graphic displays are shown in Figure 1-5. See IM-106-4050, OxyBalance Oxygen Display and Averaging System, for additional details.

**FIGURE 2-6. OxyBalance Displays**

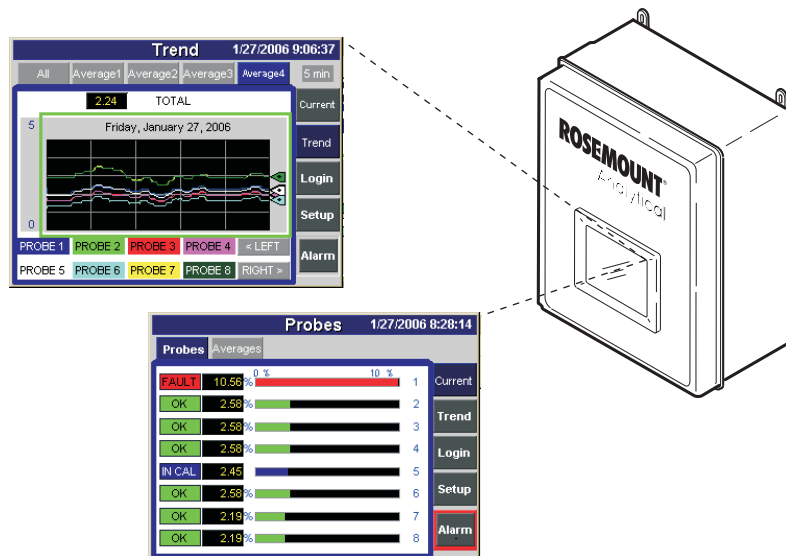

## 2.3 Specifications

### Measurement Specifications

Net O2 Range:	0 to 50% O2 user scalable -2 to 50% O2 user scalable with stoichiometer
Lowest Detectable Limit:	0.01% O2
Signal Stability:	±0.03% O2
Accuracy in Reducing Conditions:	±10% of reading or 0.1% O2
System Response in Reducing Conditions:	going from oxidizing to reducing -T90 in 120 seconds going from reducing to oxidizing -T90 in 30 seconds
Ambient Temperature Effect on Xi 4-20 mA Signal:	less than 0.0025% O2 per degree Celsius

### Environmental Specifications

6888Xi Advanced Electronics:	Type 4X, Polycarbonate Material
Ambient Temperature Limits:	-20 °C to 50 °C (-4 °F to 122 °F) -20 °C to 70 °C (-4 °F to 158 °F) as measured by electronics
6888Xi LCD display:	
Ambient Temperature Limits	-20 °C to 55 °C (-4 °F to 131 °F)
General Purpose Certifications:	



### Installation Specifications

Mounting:	Panel, wall, or pipe.
Reference Air:	2 scfh (1L /min), clean, dry, instrument-quality air (20.95% O2), regulated to 5 psi (34 kPa)
Calibration:	Semi-automatic or automatic
Cal Gases:	0.4% O2 and 8% O2, balance N2 recommended
Traditional Architecture Cable	200 ft (61 m) maximum length
Transmitter Electrical Power:	12 - 24 VDC (loop-powered from control room or 6888Xi)

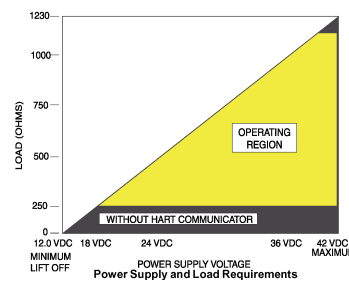

Electrical Power for 6888Xi:	120/240VAC ±10%, 50/60 Hz
Power Consumption of 6888Xi:	12 VA maximum or 1020 VA maximum with Traditional Architecture, 120V Probes
Alarm Relay Outputs:	Two provided - 2 Amperes, 30 VDC, Form-C
Optional Loss of Flame Input:	Internally powered input to remove heater power actuated via dry contact output from user's flame scanner

**CE** Emerson has satisfied all obligations from the European legislation to harmonize the product requirements in Europe. All static performance characteristics are with operating variables constant. Specifications subject to change without notice.



Table 2-1. Product Matrix, Advanced Electronics

6888Xi	Advanced Electronics
--------	----------------------

Code	Remote Type
10XY	Single Channel O2
20XY	Single Channel O2 with Flame Safety Interlock for Heater
30XY	Dual Channel O
40XY	Single Channel O2, Traditional Architecture for 120V Probes

Code	Mounting
00	No Hardware
01	Panel Mount Kit with Gasket
02	2" Pipe / Wall Mount Kit

Code	Cable
00	No Cable
10	20' (6m) Cable
11	40' (12m) Cable
12	60' (18m) Cable
13	80' (24m) Cable
14	100' (30m) Cable
15	150' (45m) Cable
16	200' (60m) Cable

Code	Stoichiometer Function
00	No
01	Single Channel
02	Dual Channel

Code	Programmable Reference Function
00	None
01	Single Channel
02	Dual Channel

Code	Extended Temperature Function
00	None
01	Single Channel
02	Dual Channel

Code	Plugged Diffuser Diagnostic Function
00	None
01	Single Channel
02	Dual Channel

**Table 2-2. Product Matrix, O<sub>2</sub> Autocalibration Accessories**

XSO2CAL	O2 Autocalibration Accessories
<b>Code</b>	<b>Single Probe Sequencers Autocalibration Options</b>
00	None
01	SPS 4001B Single Probe Sequencer, general purpose NEMA 4X, includes check valve for probe

**TABLE 2-3. Calibration Glass**

Part Number	Description
1A99119G01	Two disposable calibration gas bottles - 0.4% and 8% O <sub>2</sub> , balance nitrogen - 550 liters each *
1A99119G02	Two flow regulators for calibration gas bottles
1A99119G03	Bottle rack

\*Calibration gas bottles cannot be shipped via airfreight.

## Section 3: Installation

 **WARNING**

Before installing this equipment read the "Safety instructions for the wiring and installation of this apparatus" at the front of this Manual. Failure to follow safety instructions could result in serious injury or death.

---

 **WARNING**

Install all protective equipment covers and safety ground leads after installation. Failure to install covers and ground leads could result in serious injury or death.

---

 **WARNING**

The 6888Xi Advanced Electronics can be installed in general purpose areas only. Do not install the 6888Xi in hazardous areas or in the vicinity of flammable liquids.

---

 **CAUTION**

If external loop power is used, the power supply must be a safety extra low voltage (SELV) type.

---

## 3.1 System considerations

A typical system installation for a 6888Xi and O<sub>2</sub> Probe is shown in Figure 3-1.

FIGURE 3-1. Typical System installation

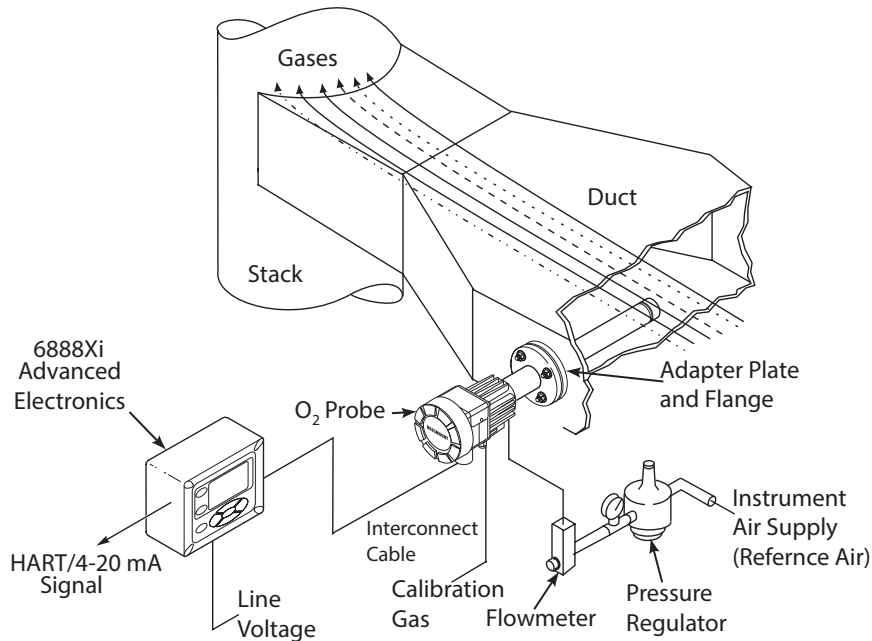

## 3.2 Mechanical installation

### 3.2.1 6888Xi Advanced Electronics

The 6888Xi Advanced Electronics is available in a panel mounting, wall mounting, or pipe mounting configuration. Refer to Figure 3-2 or Figure 3-3 for the panel, wall, or pipe mounting details.

1. Ensure all components are available to install the 6888Xi.
2. Select a mounting location near or removed from the O<sub>2</sub> Probe. Consider the temperature limitations of the 6888Xi (see "Specifications") when selecting the mounting location.
3. Mount the 6888Xi at a height convenient for viewing and operating the interface. Approximately 5 ft (1,5 m) is recommended.
4. The keypad window on the 6888Xi may have interior and exterior protective membranes. Remove the protective membranes prior to use of the 6888Xi enclosure. Failure to remove the protective membranes may cause the display to appear distorted. The membrane may be difficult or impossible to remove after extended use at elevated temperatures.

**FIGURE 3-2. 6888XI Advanced Electronics - Panel Mounting Details**

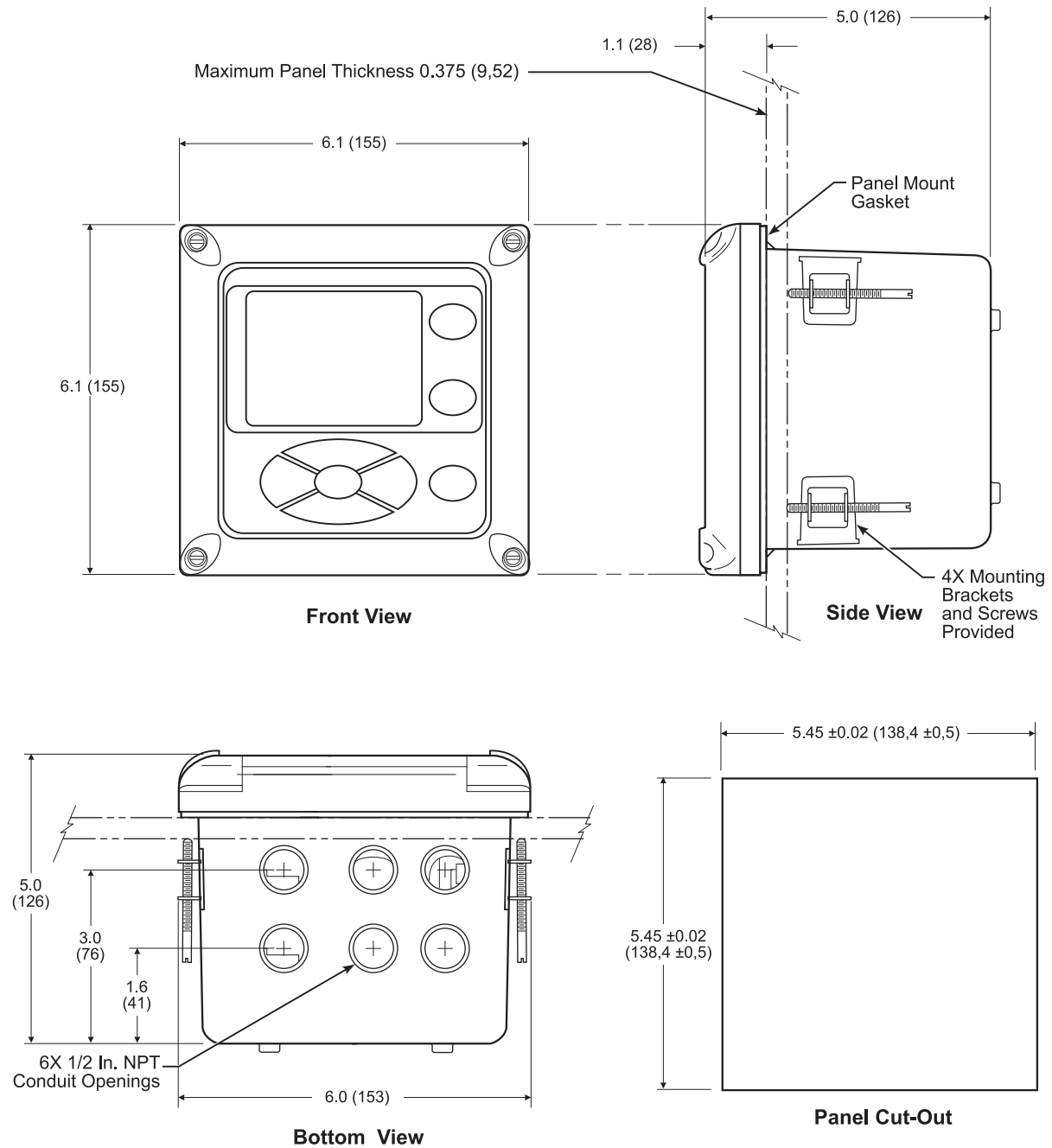

- NOTES: 1. Dimensions are in inches with millimeters in parentheses.  
2. The front panel is hinged at the bottom. The panel swings down for easy access to the wiring locations.

FIGURE 3-3. 6888XI Advanced Electronics - Wall/Surface and Pipe Mounting Details

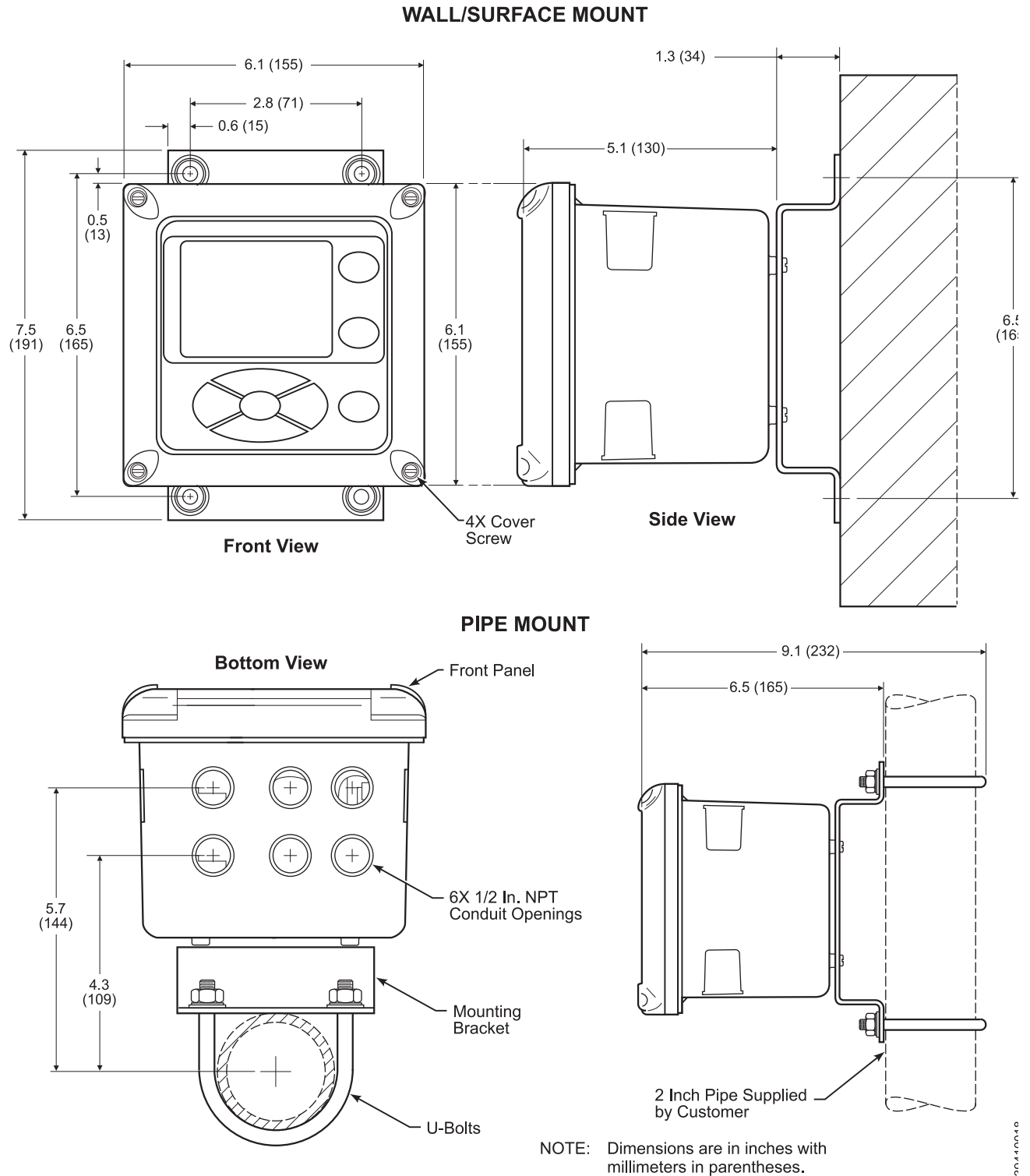

## 3.3 Electrical installation

### 3.3.1 Rosemount 6888Xi Advanced Electronics

All wiring must conform to local and national codes. Multiple wiring diagrams are shown in this section. Always refer to the diagrams that apply to your transmitter configuration and disregard all other wiring diagrams.

#### WARNING

Disconnect and lock out power before connecting the power supply.

#### WARNING

Install all protective covers and safety ground leads after installation. Failure to install covers and ground leads could result in serious injury or death.

#### WARNING

To meet the Safety Requirements of IEC 61010 (EC requirement), and ensure safe operation of this equipment, connection to the main electrical power supply must be made through a circuit breaker (min 10A) which will disconnect all current-carrying conductors during a fault situation. This circuit breaker should also include a mechanically operated isolating switch. If not, then another external means of disconnecting the supply from the equipment should be located close by. Circuit breakers or switches must comply with a recognized standard such as IEC 947.

#### NOTE

Line voltage, signal, and relay wiring must be rated for at least 105 °C (221 °F).

#### NOTE

If metal conduit is used with the 6888Xi the conduit should be reliably bonded to protective earth. The grounding plate inside the 6888Xi is not bonded to PE and does not provide adequate grounding.

1. Remove cover screws from the front cover of the 6888Xi. Swing down the front cover of the interface box.
2. Pull out the I/O board on the right-hand side of the card rack inside the 6888Xi. If your system is configured to operate two transmitter probes there are two I/O interface boards.
3. See Figures 2-5, 2-6 and 2-7. Connect the 4-20 mA signal wires at J4 of the I/O board. Attach the supplied ferrite clamp over the 4-20 mA OUT wires that extend past the shield.

#### NOTE

Installation of the ferrite clamp over the 4-20 mA OUT wires is required for compliance with the European EMC Directive.

4. Terminate the shield of the 4-20 mA signal wires at the designated ground terminal of the 6888Xi. Do not allow bare shield wires to contact the circuit boards. Insulate the shield wires prior to termination.
5. Connect the signal wires from the SPS (if used) to the applicable terminals of J3. Refer to the SPS manual for wiring details.

6. Connect the customer's alarm indicator devices to the alarm indicator relay terminals.
7. Reinstall the I/O board in the card rack of the 6888Xi.
8. If your system is configured for two channel operation, repeat steps 2 through 7 to connect the other signal wires.
9. Remove the connector from the power supply board located on the left-hand side of the card rack inside the 6888Xi.
10. Connect the line, or L1 wire to the L1 terminal and the neutral, or L2 wire, to the N terminal.
11. Reinstall the power supply connector in the power supply board.

#### Flame Safety Interlock

A flame safety interlock by Emerson is available for heater power disconnect whenever there is a loss of the process flame or a heater runaway condition (heater over-temperature) in the O<sub>2</sub> Probe. This input is internally powered by the 6888Xi and is actuated via a dry contact output from the user's flame scanner. A closed contact indicates a flame is present. An open contact indicates a loss of flame.

1. Connect the signal wires from the burner management system flame status output to the flame status input terminals of J2. The flame status sensing device is supplied by the customer. Refer to the applicable OEM documents for signal wiring details.
2. Remove the J1 and J2 connectors from the AC relay board.
3. Connect the AC line input to the J1 connector.
4. Connect the AC power to the 6888A probe to the J2 connector.
5. Reinstall connector J1 and J2 to the AC relay board.

#### Traditional Architecture Cable Connections

A traditional architecture configuration is used to provide for remote location of the transmitter electronics. All electronics are housed inside the 6888Xi. A multi-conductor power/signal cable connects between the probe and the 6888Xi. Use the following procedure to connect the traditional architecture probe to the 6888Xi.

---

#### NOTE

The Traditional Architecture cable is provided at the specified length and is ready for installation. The cable glands must be properly terminated to maintain EMC/EMI noise protection.

---

**FIGURE 3-4. Traditional Architecture Cable Gland Assembly**



1. Run the 7-conductor cable between the traditional architecture probe and the installation site for 6888Xi. Use new cable conduit or trough as needed.
2. Install the cable and lead wires to the probe per manufacturer's instructions.
3. Install the cable at the probe housing and at the 6888Xi enclosure according to the following procedure:
  - a. Unscrew locking nut from gland assembly, Figure 2-4, and slide locking nut back along cable.
  - b. Pull the gland body away from the plastic insert. Use care not to damage the cable shield braid.
  - c. Insert the cable wires into the proper entry port in either the probe housing or the 6888Xi enclosure.
  - d. At the probe housing, apply Teflon tape or similar sealing compound to the tapered pipe threads. Thread the gland body into the probe housing until properly seated.



- e. At the 6888Xi enclosure, insert the gland body into the left front cable port from the inside of the enclosure. Use the rubber O-ring provided to seal the cable port.
  - f. Ensure the cable shield braid is evenly formed over the gray insert. When properly formed, the braid should be evenly spaced around the circumference of the insert and not extend beyond the narrow diameter portion.
  - g. Carefully press the gray insert into the gland body. The grooves on the insert should align with similar grooves inside the gland body. Press the insert in until it bottoms out in the gland body.
  - h. Slide the locking nut up and thread it onto the gland body. Tighten the locking nut so the rubber grommet inside the plastic insert compresses against the cable wall to provide an environmental seal.
- 4 At the 6888Xi, connect the cable leads to the connectors on the transmitter I/O board as indicated in Figure 2-7.

FIGURE 3-5. Single/Dual Channel Wiring Diagram

- NOTES:
- EXCEPT FOR JP5, JP7 AND JP8 ON IO BOARD, JUMPER AND SWITCH SETTING ARE FACTORY SET AND ARE SHOWN FOR REFERENCE ONLY.
  - IO BOARD 4-20mA/HART LOOP POWER SETTINGS  
 JP5: PINS 1-2 INTERNAL POWER 6888XI TO 6888 TRANSMITTER  
 PINS 2-3 EXTERNAL POWER 6888XI TO 6888 TRANSMITTER  
 (REQUIRES 250Ω RESISTOR ACROSS J4, PR+ TO PR-)  
 JP7/JP8: PINS 1-2 INTERNAL POWER 6888XI TO DCS  
 PINS 2-3 EXTERNAL POWER 6888XI TO DCS

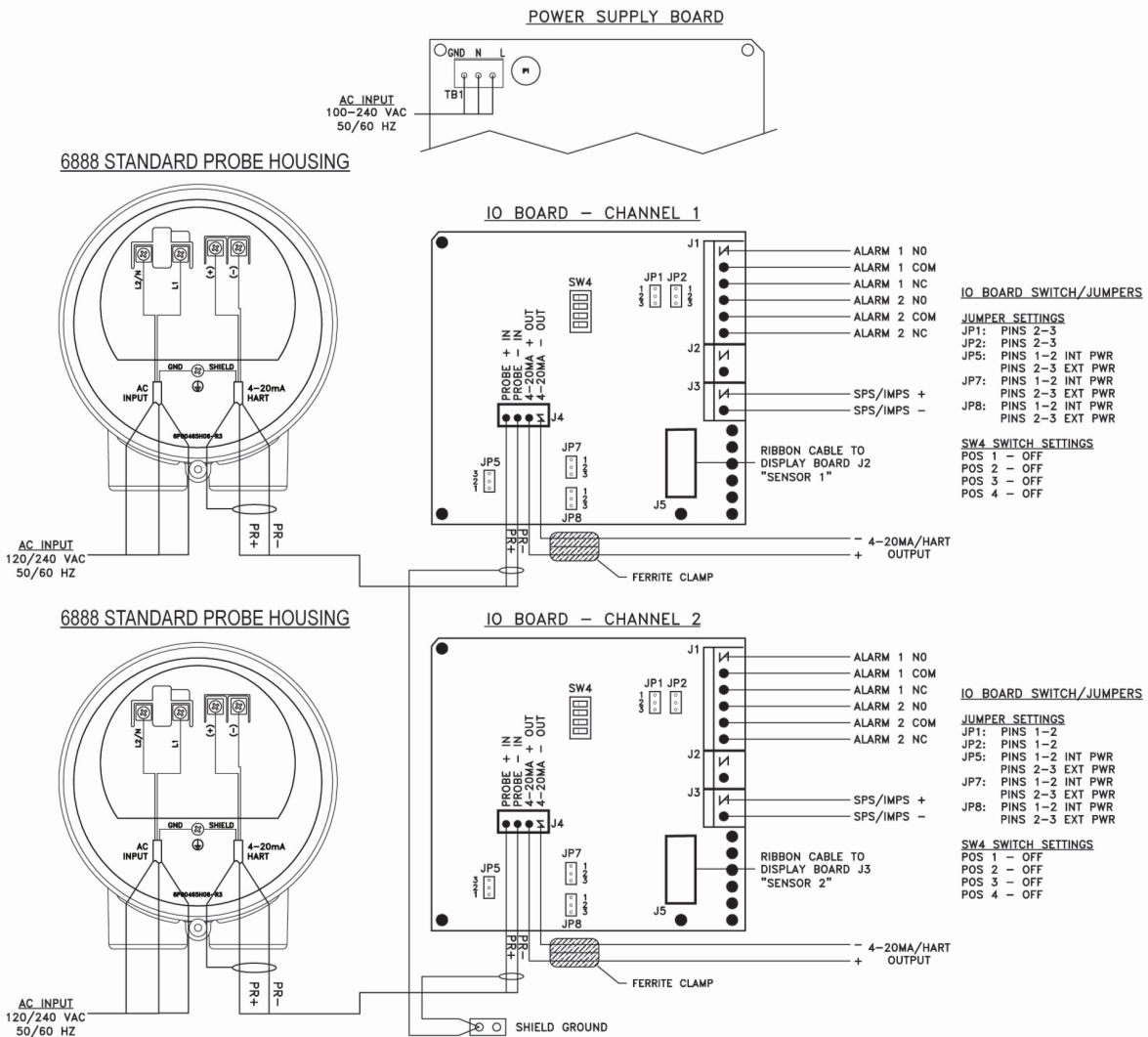

FIGURE 3-5 cont. Single/Dual Channel Wiring Diagram

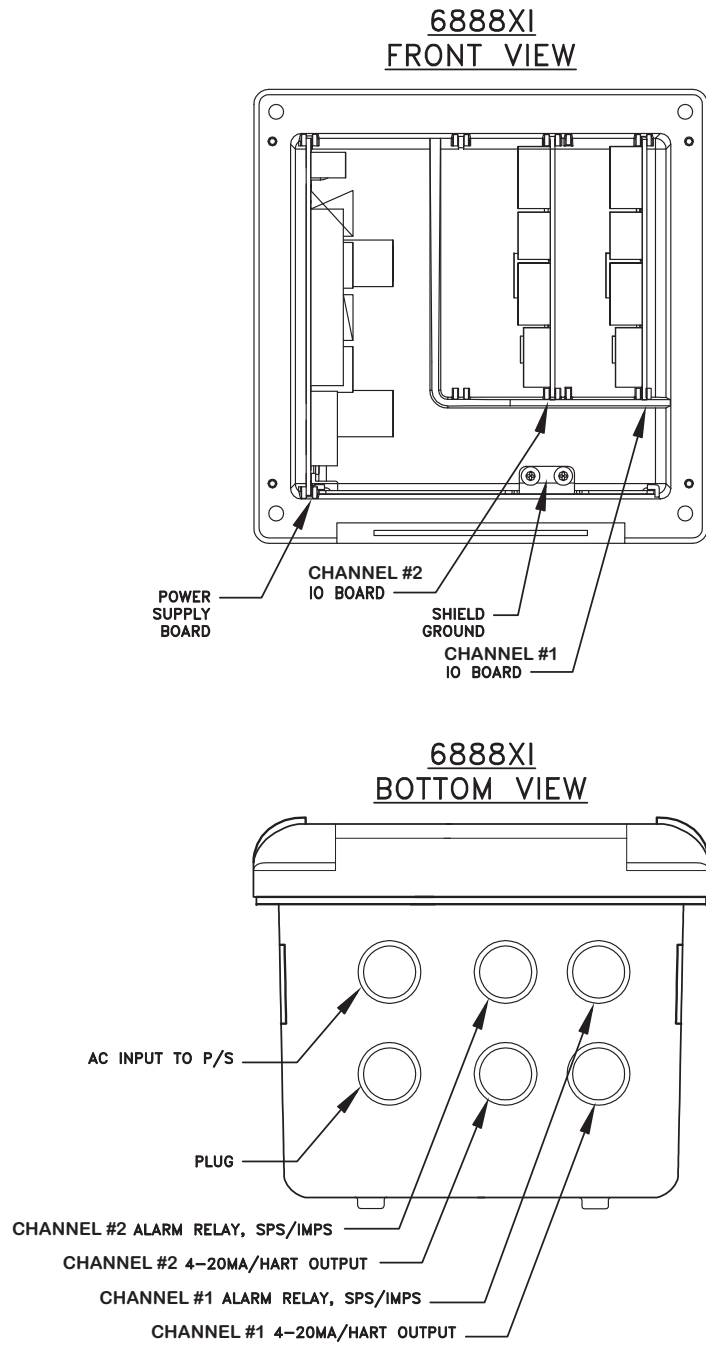

FIGURE 3-6. Single Channel with Flame Safety Wiring Diagram

NOTES:

1. SEE INSTRUCTION MANUAL 51-6888Xi FOR ADDITIONAL INSTALLATION AND OPERATING INSTRUCTIONS.
2. ALL WIRING MARKED WITH AN ASTERISK (\*) IS FACTORY WIRING INSIDE THE 6888XI.
3. EXCEPT FOR JP5, JP7 AND JP8 ON IO BOARD, JUMPER AND SWITCH SETTING ARE FACTORY SET AND ARE SHOWN FOR REFERENCE ONLY.
4. IO BOARD 4-20mA/HART LOOP POWER SETTINGS  
 JP5: PINS 1-2 INTERNAL POWER 6888XI TO 6888 TRANSMITTER  
 PINS 2-3 EXTERNAL POWER 6888XI TO 6888 TRANSMITTER  
 (REQUIRES 250Ω RESISTOR ACROSS J4, PR+ TO PR-)  
 JP7/JP8: PINS 1-2 INTERNAL POWER 6888XI TO DCS  
 PINS 2-3 EXTERNAL POWER 6888XI TO DCS

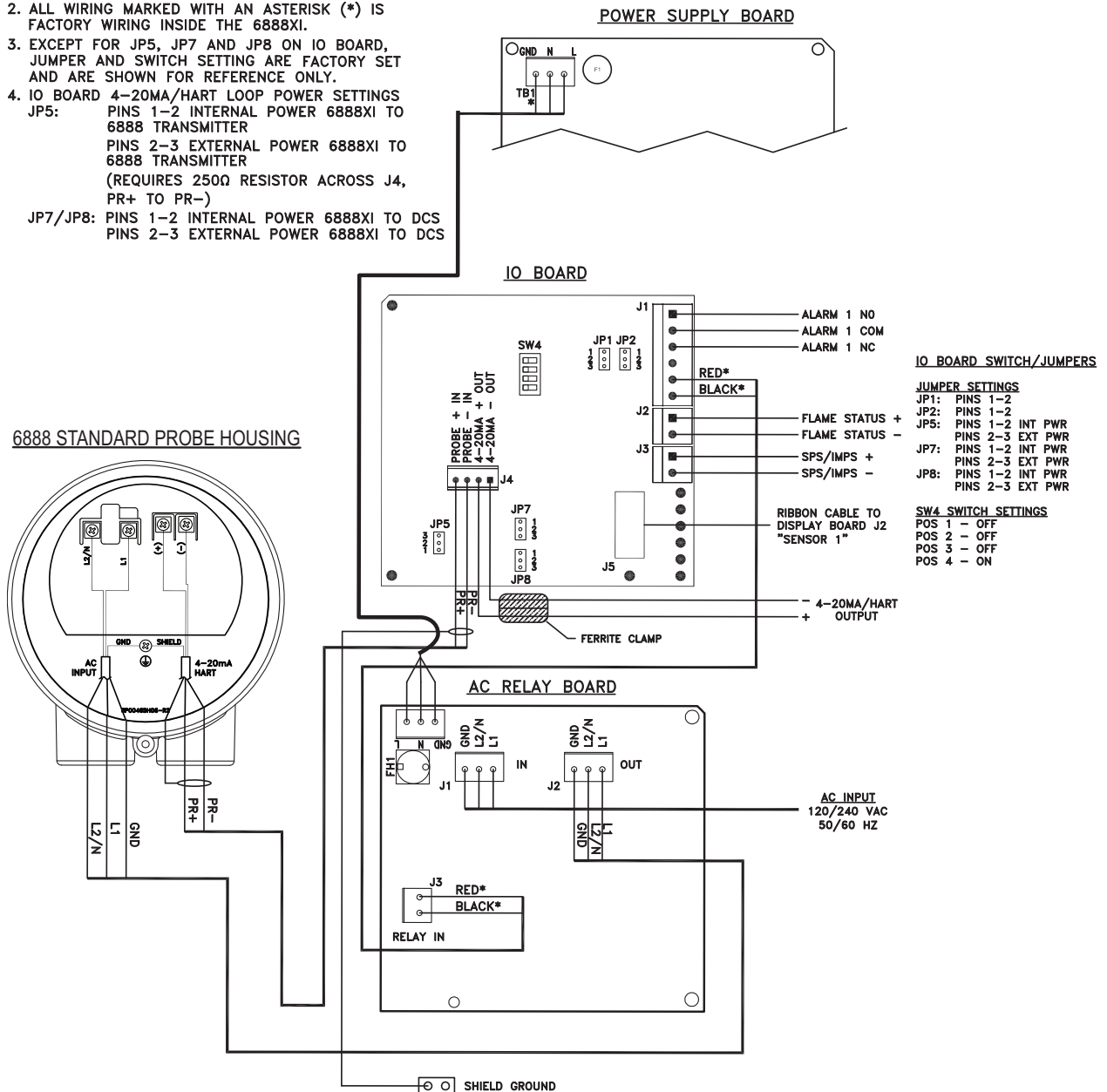

FIGURE 3-6 cont. Single Channel with Flame Safety Wiring Diagram

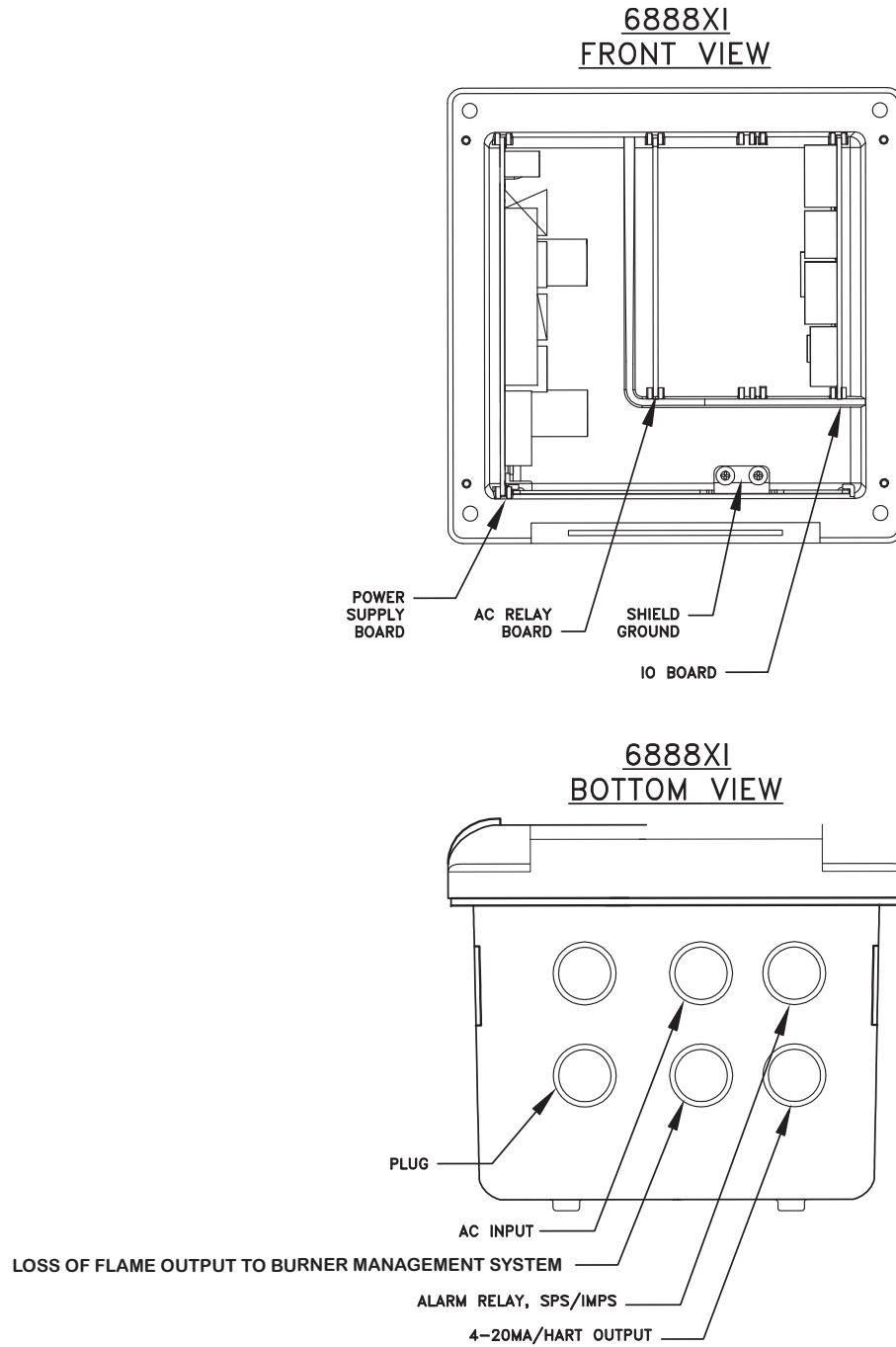

FIGURE 3-7. Traditional Architecture Wiring Diagram

NOTES:

1. SEE INSTRUCTION MANUAL FOR ADDITIONAL INSTALLATION AND OPERATING INSTRUCTIONS.
2. ALL WIRING MARKED WITH AN ASTERISK (\*) IS FACTORY WIRING INSIDE THE 6888XI.
3. EXCEPT FOR JP7 AND JP8 ON IO BOARD, JUMPER AND SWITCH SETTING ARE FACTORY SET AND ARE SHOWN FOR REFERENCE ONLY.

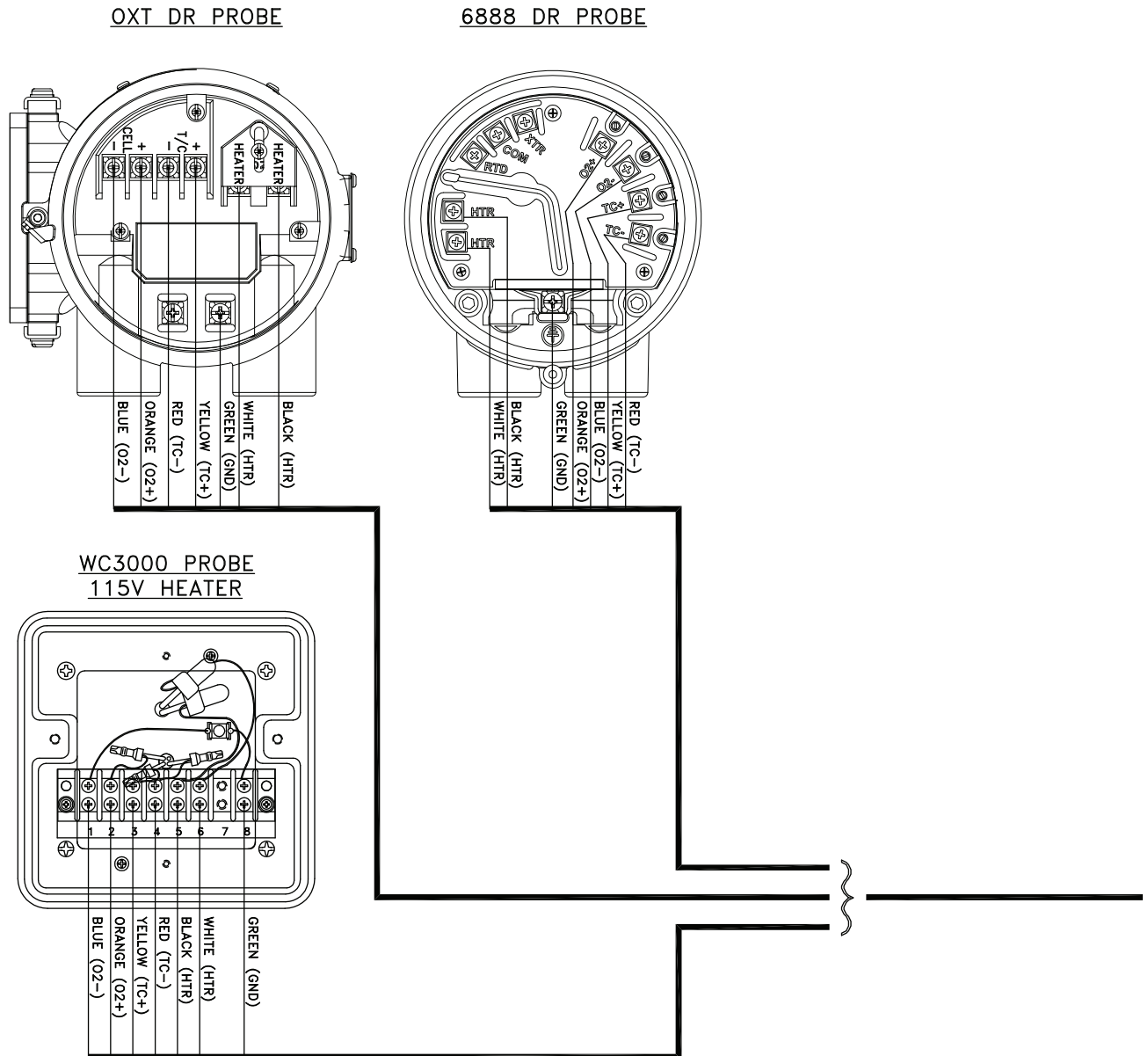
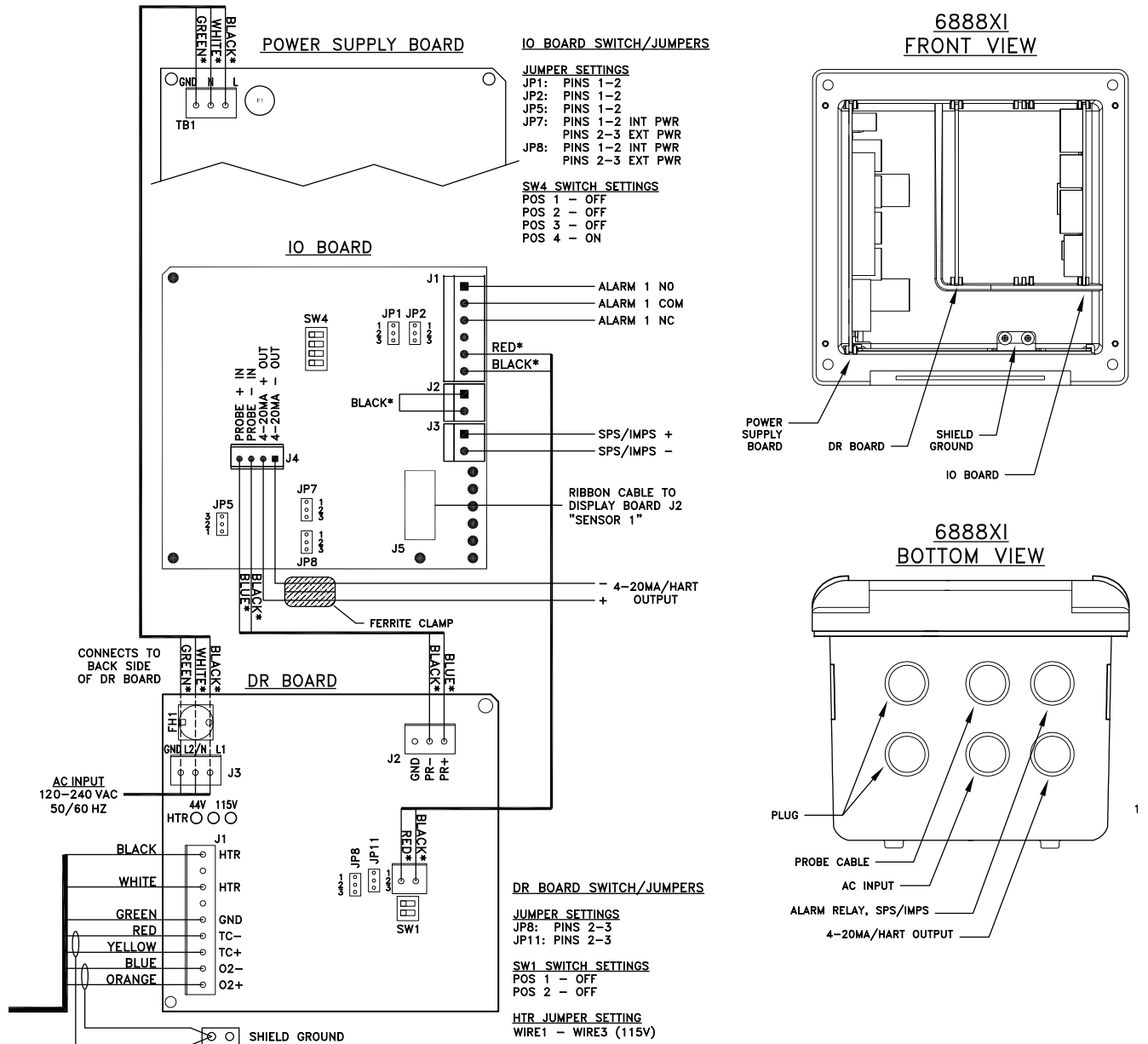

FIGURE 3-7 cont. Traditional Architecture Wiring Diagram







# Section 4: Configuration, start-up, and operation

## WARNING

Install all protective equipment covers and safety ground leads before equipment startup. Failure to install covers and ground leads could result in serious injury or death.

## CAUTION

If external loop power is used, the power supply must be a safety extra low voltage (SELV) type.

## 4.1 Overview

Interface to the 6888Xi for setup, calibration and diagnostics can be via a 375/475 Field Communicator or Asset Management System. Setup, calibration and diagnostic operations will differ depending on the selected interface for communications with the transmitter.

## 4.2 Start-up

### NOTE

The 6888Xi offers optional advanced features such as extended temperature capability, autocalibration via an SPS, a stoichiometer feature for indicating the level of oxygen deficiency in reducing conditions, programmable reference to enhance accuracy at near ambient levels of O<sub>2</sub> and plugged diffuser diagnostics to help detect when the diffuser requires maintenance.

### 4.2.1 Configuration

Refer to Figure 3-1 for the configuration of jumpers JP1 through JP8. The jumper configuration for your I/O board depends on the system design and system components used in your installation.

The setting of switch SW4 and the configuration of jumpers JP1 through JP8 must be verified on the I/O board in the 6888Xi. Refer to figures 2-5, 2-6 and 2-7 in Section 2 for additional details.

If necessary, the I/O Board can be reset to factory default settings in order to configure the following parameters:

Sensor Type – O<sub>2</sub> or CO

O<sub>2</sub> - For Rosemount O<sub>2</sub> probe models including Oxymitter and 6888, and most similar competitor oxygen probes

CO - Reserved for future use

Device Type – HART or FOUNDATION Fieldbus

1. HART - For Rosemount O<sub>2</sub> probes models including Oxymitter and 6888, and most similar competitor oxygen probes

2. FOUNDATION Fieldbus - For 6888 models with FOUNDATION Fieldbus electronics only
  - Autocal Setting – None, SPS, or Integral
    1. None – Manual calibration with the standard probe housing configuration
    2. **SPS** - Automatic calibration with the standard probe housing configuration using the SPS4001B
    3. **Integral** – Automatic calibration with the 6888 integral autocal probe housing configuration.

**WARNING**  
Resetting the I/O Board clears any existing probe data.

To reset the I/O board:

1. Apply power to 6888XI.
2. Press MENU until the “System” menu appears.
3. Select CONFIGURE IOB.
4. Press the ENTER key to continue.
5. Select I/O BOARD 1. (Note: With a dual channel 6888XI, either or both I/O boards may be reset and reconfigured.)
6. Press the ENTER key to continue.
7. Select RESET I/O BOARD. Press the ENTER key to continue.
8. When the reset menu appears, select FACTORY DEFAULTS. Press the ENTER key to continue.

**FIGURE 4-1. I/O Board Jumper Configuration**

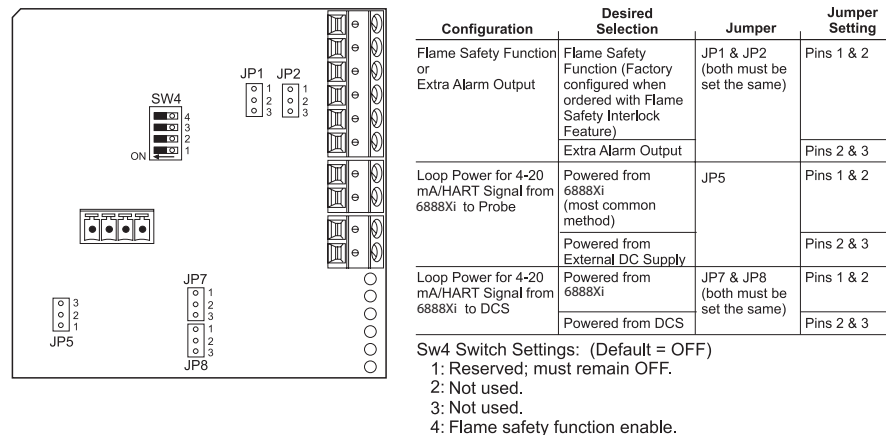

## 4.2.2 Operation

The following procedures describe operations using the 6888Xi to set up and calibrate the system. Additional operating instructions are included in the SPS 4001B manual, if applicable to your system.

## 4.2.3 Start-up display

The O<sub>2</sub> Probe will take approximately 45 minutes to warm up to the 736 °C heater setpoint. The 4-20 mA signal will remain at a default value of 3.5 mA through this warm-up period. Once warm, the probe will be reading oxygen and the 4-20 mA signal display will be the 0 to 10% O<sub>2</sub> value.

FIGURE 4-2. 6888Xi Display (Typical)

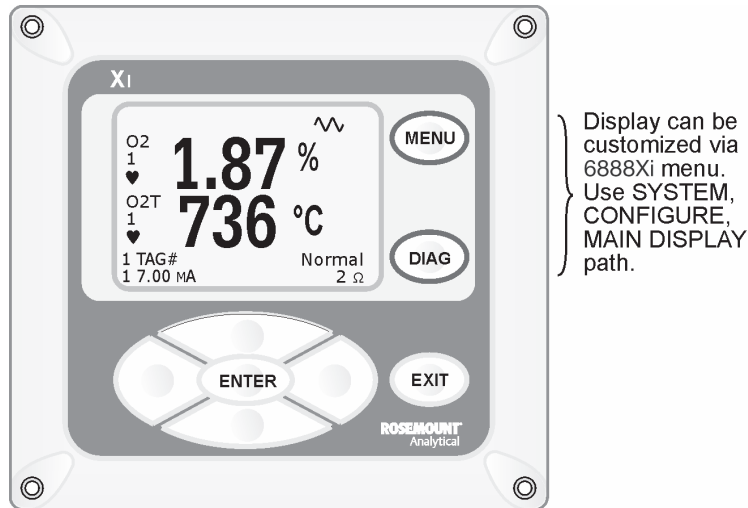

## 4.2.4 Error conditions

If there is an error condition at startup, an alarm message will be displayed. Refer to Section 4: Troubleshooting, to determine the cause of the error. Clear the error and cycle power. The O<sub>2</sub> and temperature display should return less the alarm message.

## 4.2.5 Keypad

The 6888Xi can be used to change the software and alarm settings, to adjust the high and low gas settings, and to initiate the calibration sequence. Refer to the following control descriptions. Use the control keys on the front panel of the 6888Xi, Figure 3-2, to navigate the 6888Xi menu, Figure 3-3.

**MENU** toggles between three Main menu options: System, Probe1, and Probe2 (if available). The top level of the selected main menu is displayed.

**DIAG** toggles between the Alarms list of the three main menus. All faults and warnings related to the selected main menu device are displayed.

**ENTER** saves newly entered data and returns you to previous menu level.

**EXIT** returns you to the previous menu level without saving newly entered data. When navigating the menu tree, pressing EXIT returns you to the Main menu.

**UP/DOWN** keys scroll up and down through menu items. During data entry the Up/Down keys increment and decrement the data values.

**LEFT** arrow key returns you to the previous menu level. During data entry, the left arrow key moves the cursor one digit to the left.

**RIGHT** arrow key advances you to the next menu level and, when a menu item is highlighted, selects the item from a list of menu options. During data entry, the right arrow key moves the cursor one digit to the right.

## 4.2.6 Password protection

The main display and diagnostic screens of the 6888Xi can be viewed at any time, but further access and unauthorized configuration changes can be prevented by enabling a password protection feature. However, the 6888Xi is shipped with password protection disabled.

Password protection can be enabled by selecting: System Main Menu > Configure UIB > Security > Enable Password (see the 6888Xi Menu, Figure 3-3).

Figure 4-3. 6888Xi Menu (Sheet 1 of 6)

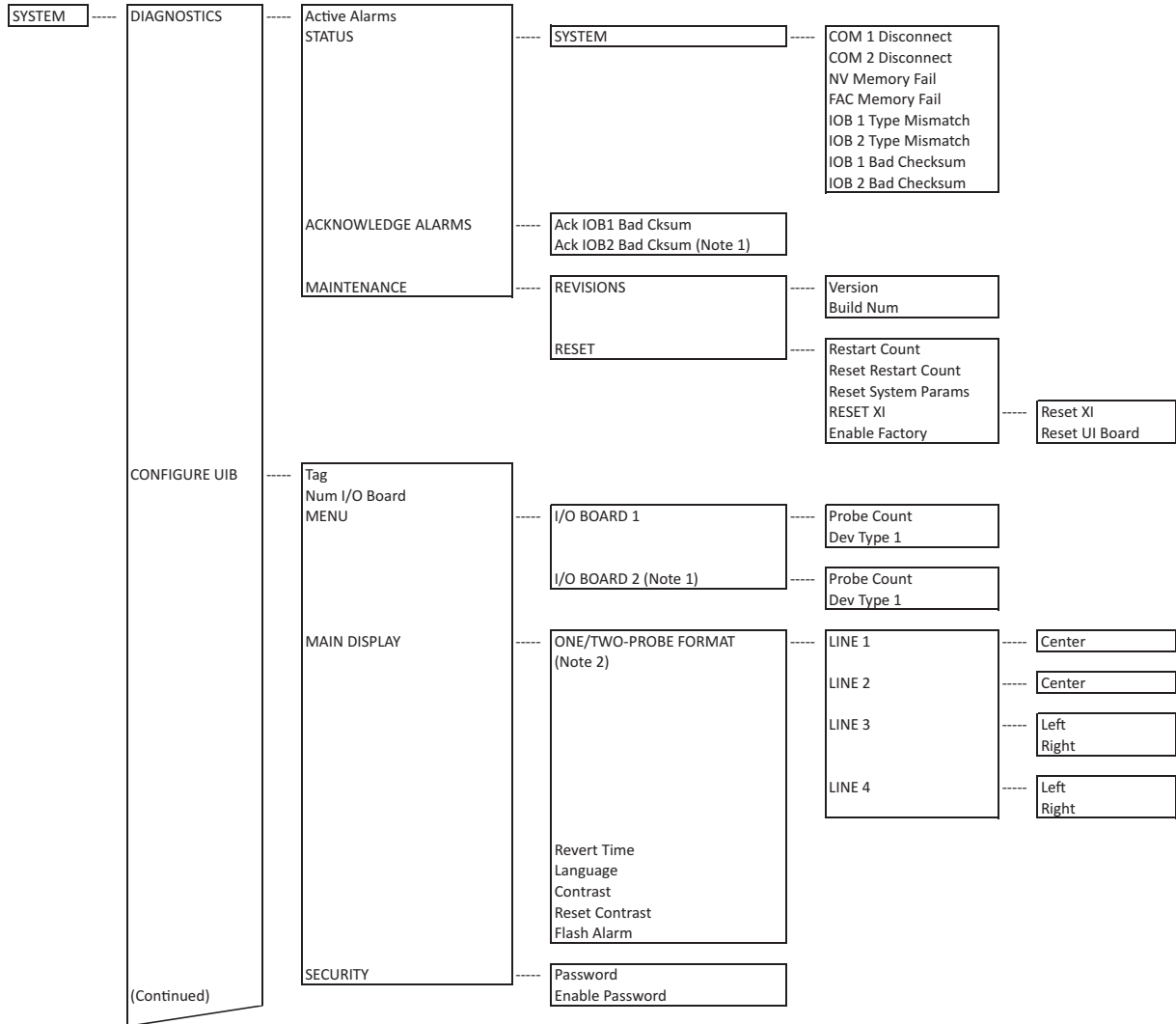
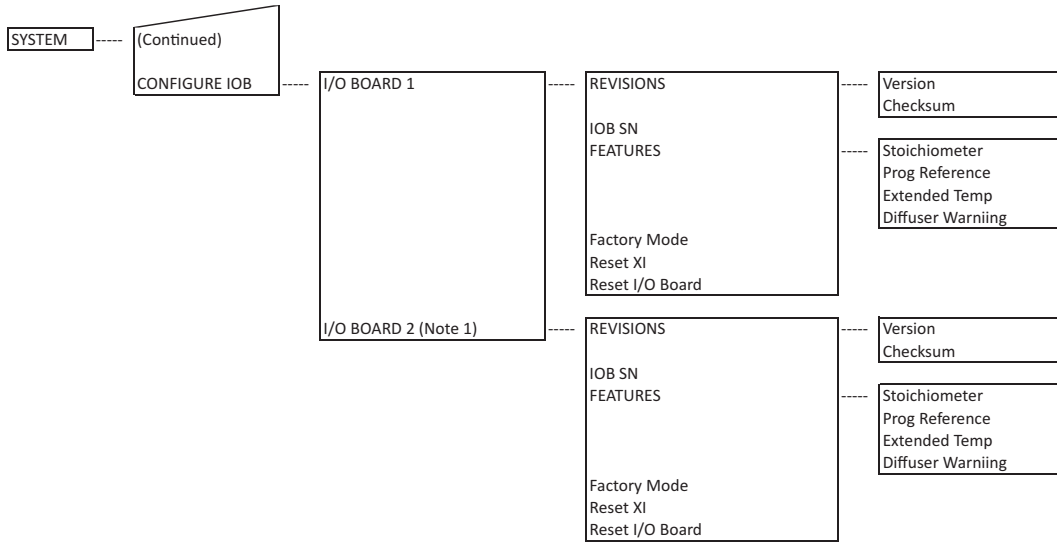

Figure 4-3. 6888Xi Menu (Sheet 2 of 6)



Note 1: Visible if the device is configured for 2 I/O boards.  
Note 2: Label differently based on one or two I/O boards.

Figure 4-3. 6888Xi Menu (Sheet 3 of 6)

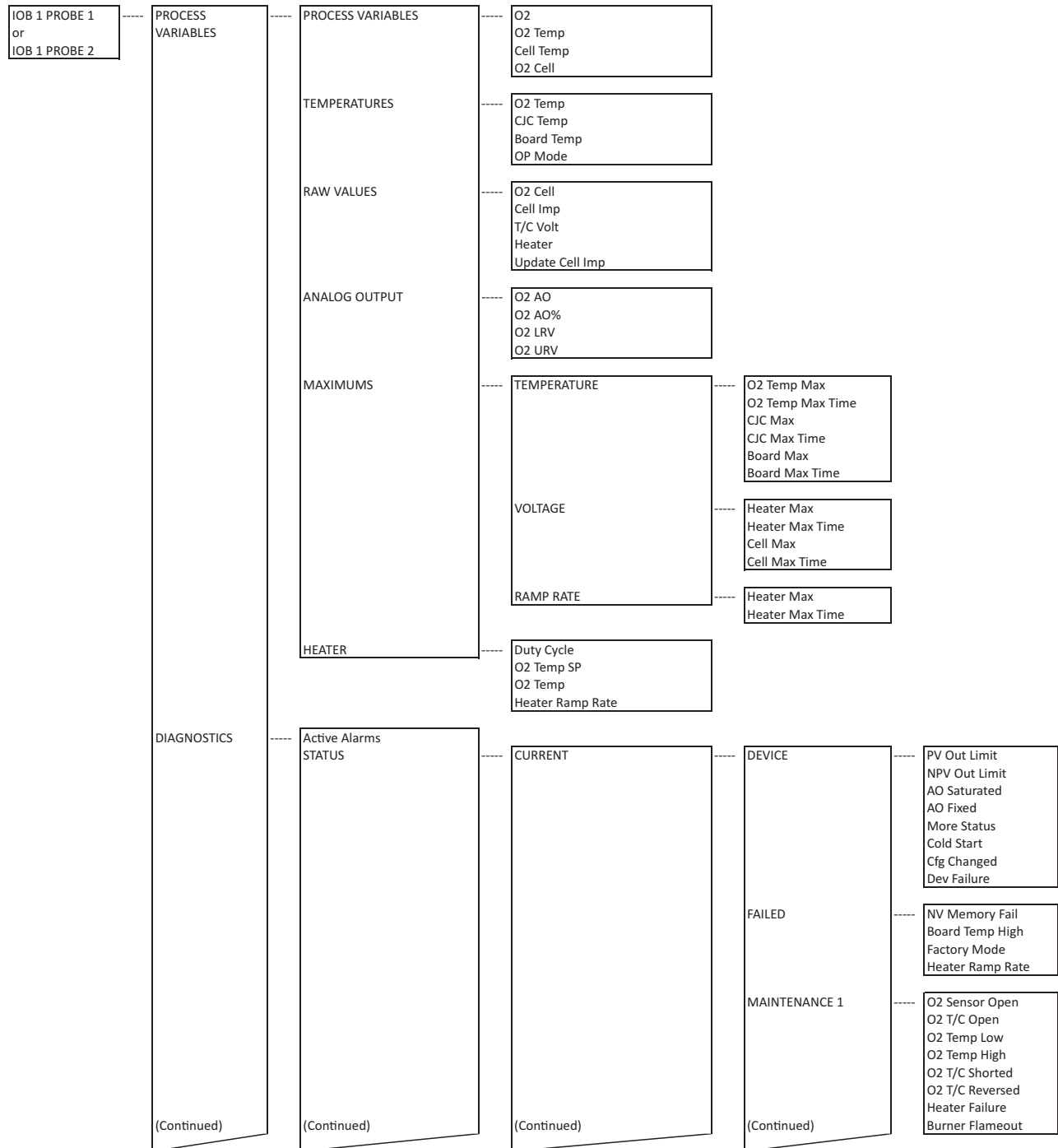

Figure 4-3. 6888Xi Menu (Sheet 4 of 6)

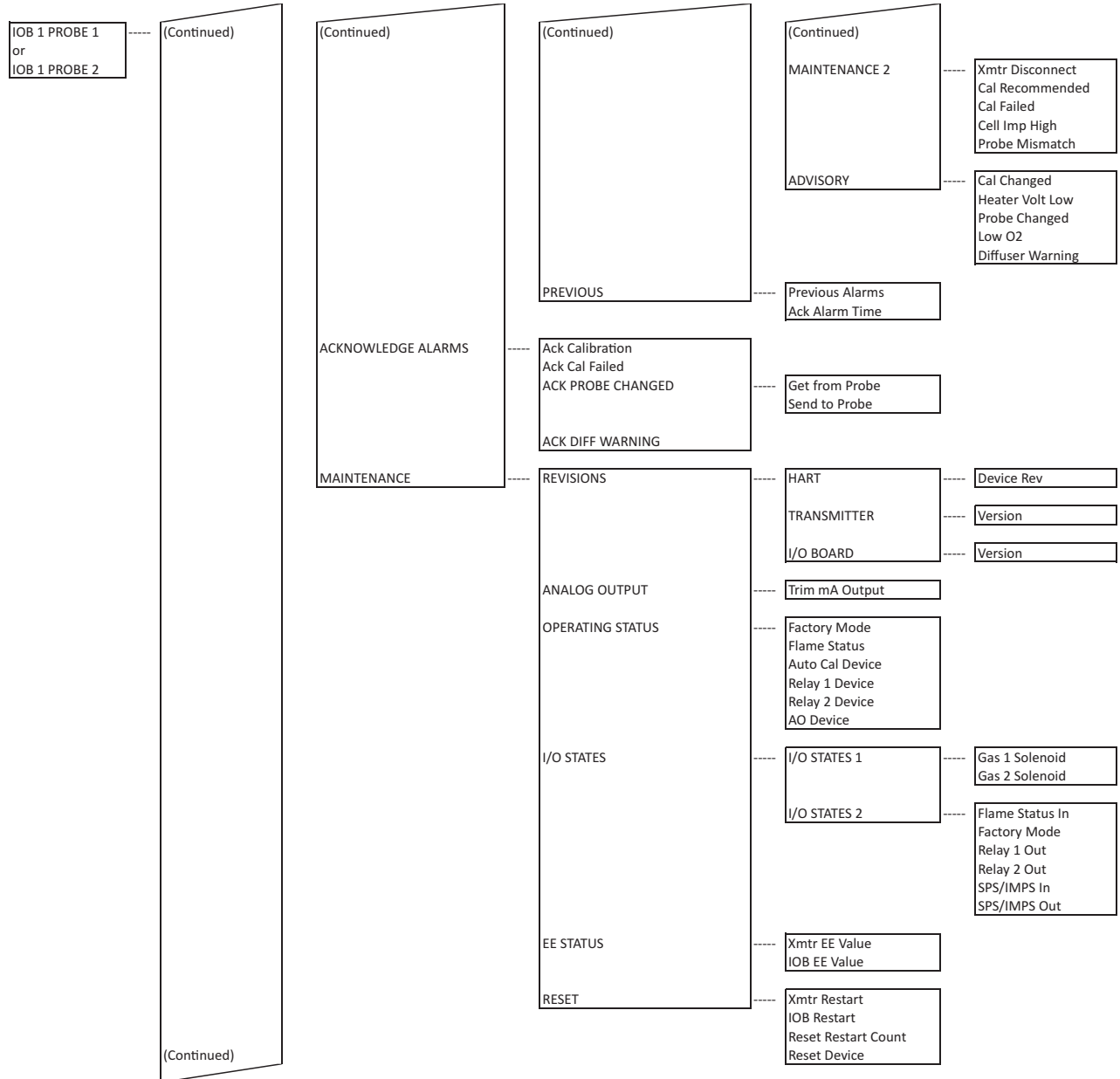

Figure 4-3. 6888Xi Menu (Sheet 5 of 6)

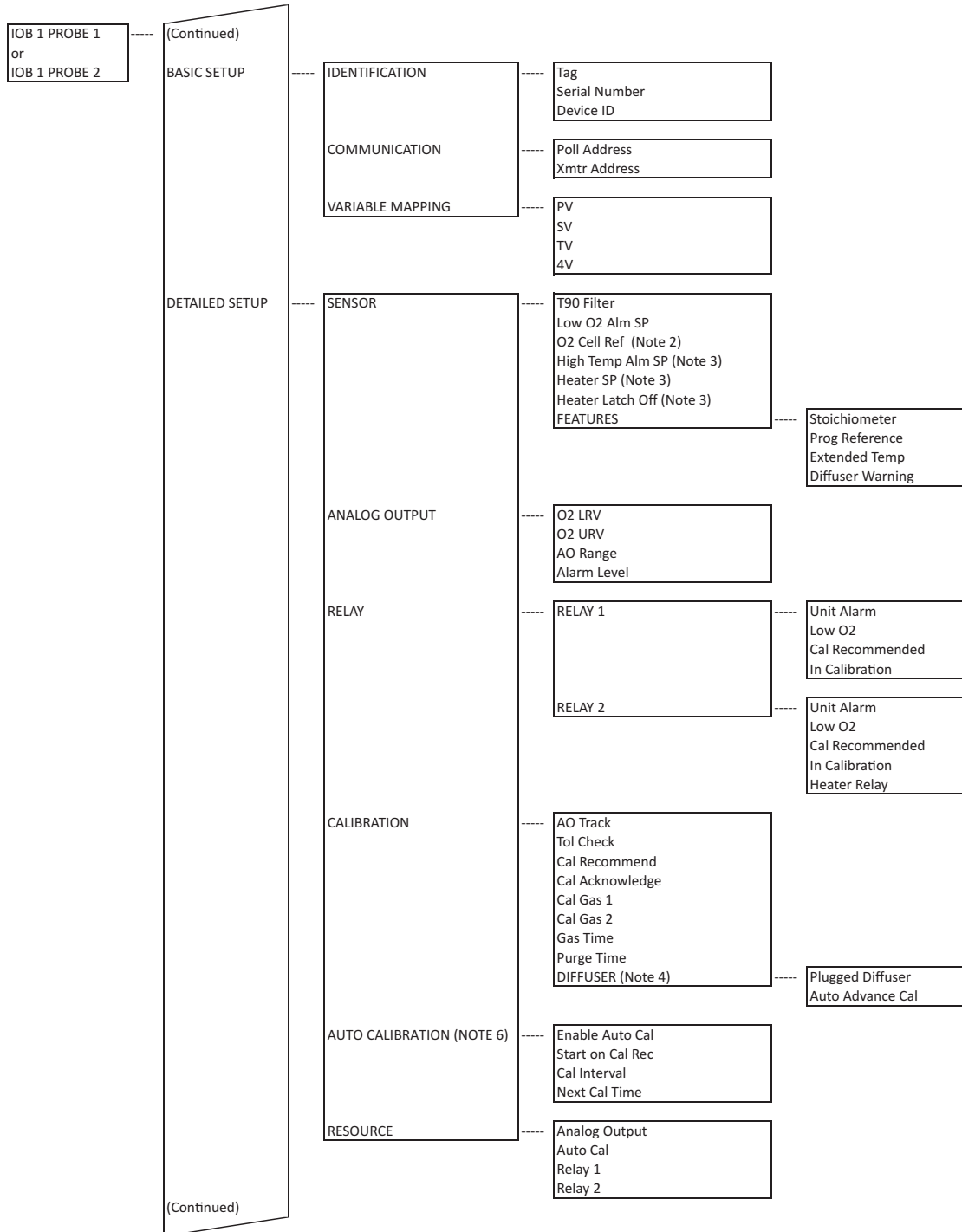
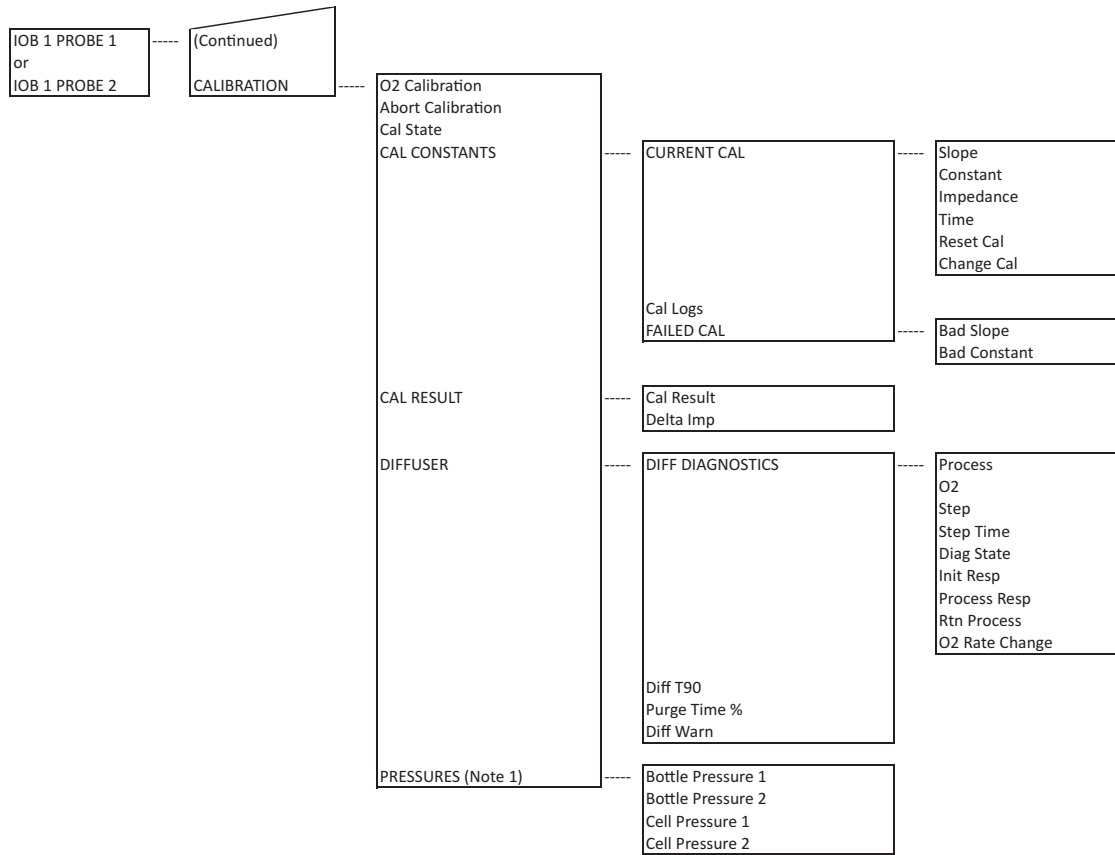



Figure 4-3. 6888Xi Menu (Sheet 6 of 6)



- Note 1: Visible if the device is configured for HSPS Autocal.
- Note 2: Visible if the Programmable Reference software feature is enabled.
- Note 3: Visible if the Extended Temperature software feature is enabled.
- Note 4: Visible if the Diffuser Warning software feature is enabled.
- Note 5: Visible if the Factory Mode switch is on.
- Note 6: Visible if the device is configured for Autocal.

The factory default upon enabling the password protection is 0000, but the password can consist of any 4 numeric characters.

If the user forgets the password, call Rosemount Customer Support Center at +1 855 724 2628 to gain access to a master password.

A "Lock" icon will be displayed at the top right corner of the main display when password protection is in effect.

The password protection will relock itself after a certain number of seconds with no button pushes (defined as "revert time" in the same "LCD setup" menu).

The 6888Xi has a "Reset" function that reestablishes all factory default conditions, including the password protection feature, i.e. the password protection will fall back to a disabled condition after a reset.

## 4.3 Optional advanced features

Advanced features are typically ordered factory programmed. However, these advanced features are also available for field retrofit.

A 6888Xi is shipped from the factory with the optional enhanced software features enabled based on the model configuration.

### 4.3.1 Extended temperature

The Oxygen Analyzer employs a heater and thermocouple to maintain a temperature normal set point at 736 °C (1357 °F). Temperature control is maintained within  $\pm 1$  °C to process temperatures of about 705 °C (1300 °F). This is satisfactory for most applications, but excursions to high-temperatures can occur in some processes.

#### WARNING

**The I/O Board is shipped from the factory without any of the enhanced software features activated. These features must be activated once the new board has been installed and before the Remote Interface is put into service.**

#### WARNING

**If the existing I/O Board has been operated with the Stoichiometric enhanced software feature, this feature must be activated in the new board before the Remote Interface is put back into service. Failure to do so will cause a false analog output signal to the DCS.**

#### NOTE

For enhanced software feature option upgrades or to enable the feature to duplicate the existing configuration, contact Emerson at 1-800-433-6076. Reference the following:

6A00269G01	Enhanced Software Option Upgrade, Stoichiometric Function
6A00269G02	Enhanced Software Option Upgrade, Programmable Reference Function
6A00269G03	Enhanced Software Option Upgrade, Extended Temperature Function
6A00269G04	Enhanced Software Option Upgrade, Diffuser Warning Function

The extended temperature function allows the heater to be turned off and the process temperature used to heat the sensing cell. The function also provided for configuring the heater to operate at either 736 °C (1357 °F) or 550 °C (1022 °F). A lower temperature may be desirable by turning off the heater at a lower temperature to reduce the instance of an ignition source in the process. Furthermore, the user has the ability to choose whether or not the heater will turn back on if the process temperature falls below the set point. Again, this reduces the instance of an ignition source in the process if a flameout condition should occur.

When the extended temperature function is disabled the heater normal set point is at 736 °C. An alarm will occur if the heater falls below 726 °C or rises above 750 °C. Either of these alarms will also force the analog output signal to a critical alarm level of either 3.5 mA or 21.5 mA as configured. When the extended temperature function is enabled, an alarm will occur if the heater falls 10 °C below the set point of either 550 °C or 736 °C and will force the analog output signal level to either 3.5 mA or 21.5 mA. With either set point, the high temperature alarm defaults to 750 °C but can be configured to any temperature between 750 °C and 850 °C. However, a heater temperature above this level will cause an alarm but will not force the analog output signal level to either 3.5 mA or 21.5 mA.

When the heater turns off, the oxygen reading is adjusted continuously to compensate for the varying process temperatures. It should be noted that cell life will be reduced by continuous operation at temperatures above 736 °C (1357 °F). If process temperatures are expected to be continuously above 705 °C, the use of an optional bypass or probe mounting jacket accessory is recommended.

### 4.3.2 Stoichiometer

Process upsets can sometimes cause a combustion process to go into sub-stoichiometric or reducing conditions. The oxygen readings from one or more probes may decline all the way to zero. The stoichiometer cell will measure the amount of oxygen deficiency during these reducing conditions. The trends in your DCS can be set up for a lower range limit of -1 or -2% oxygen to depict the level of oxygen deficiency.

The operator can see if his control recovery actions are having the desired effect. These types of events do not occur frequently, but knowing the parameters of the situation prevents over-correcting while coming out of the reducing condition. The stoichiometer feature requires purchasing the acid resistant stoichiometer cell and the stoichiometer feature inside the 6888Xi.

#### NOTE

Make sure the DCS is configured for the same range as the 6888Xi. For instance: -1% O<sub>2</sub> to 10% O<sub>2</sub>.

### 4.3.3 Programmable reference

The zirconium oxide sensing technology has historically measured process oxygen by using ambient or instrument air as a reference (20.95% oxygen). The sensor develops most of its signal at the low oxygen levels typically found in combustion flue gasses (2-4% oxygen), and is most accurate at these levels. When measuring near 20.95% O<sub>2</sub>, the sensor develops only a few millivolts of signal, and accuracy degrades.

The programmable reference feature permits the user to use a bottled reference gas of low oxygen value (0.4% oxygen recommended). When measuring at or near 21% oxygen, a strong negative oxygen signal results, with much improved accuracy. A bottle of reference gas typically lasts about a month at the low flows required. Typical applications would be:

Flue gas recirculation - controlling the mixing of flue gasses into the burner windbox prior ahead of the burner to reduce NO<sub>x</sub> emissions.

Moisture monitoring - measuring the amount of moisture coming off of industrial dryers by noting the dilution effect water vapor has on the normal 20.95% ambient drying air. (Non-combustion drying processes only.)

Enriched oxygen concentration - pure oxygen is sometimes mixed in with the combustion air to increase heat at the flame. This is used in steel and other metals reduction processes and in some catalyst regenerators.

### 4.3.4 Plugged diffusion element diagnostic

In situ analyzers do very well in high particulate flue gases resulting from processes as such coal or biofuel boilers, or lime and cement kilns because the passive filter, or "diffusion element" does not foul or plug off easily. Since the probe sensing cell is inserted entirely into the flue gas stream, the process gasses can diffuse (migrate) into the cell area with minimal fouling of the filter media. After many months or years of operation, however, the diffusion element may plug off. The operator at the DCS console may notice that the O<sub>2</sub> measurement is not as active as previously or that the speed of response back to the process (purge time) after calibration gases are removed has increased considerably. A new diffusion element will start to come back to the process value in 3-5 seconds ( $T_{initial}$ ), and will be all the way back to the process reading in 30-40 seconds ( $T_{final}$ ). As the diffuser plugs off over many months, these times will get longer and longer.

Another indication of a plugged diffuser is a large increase of the "cell constant" after a calibration. A slower speed of response not only delays O<sub>2</sub> information for the operator or the automatic O<sub>2</sub> trim control loop, it can also cause technicians to induce a calibration error while doing calibrations. Published specifications call for a 5 SCFH flow of calibration gases with a new diffuser. This slightly pressurizes the cell area with cal gas, ensuring that no flue gases mix in with the calibration test gasses. As the diffuser plugs off over time, the calibration flow rate will drop and the cell area becomes increasingly more pressurized. Pressurizing the sensing cell during the calibration procedure will induce an error in the O<sub>2</sub> reading once the calibration gases are removed and pressures return to the normal operating duct pressures. The O<sub>2</sub> reading will be shifted lower by 1.5% of reading (not 1.5% O<sub>2</sub>, or 1.5% of full scale) for every 7 inches of water column pressure induced during the calibration.

The calibration induced error will be further increased if the calibration gas flow rate is adjusted to compensate for the reduced flow caused by the plugging diffuser. For example, an instrument technician may do a calibration on a probe with a badly plugged diffuser. He notices when he opens the bottle and sets his pressure regulator to 20 PSI that the flow meter is reading 2 SCFH instead of the normal 5 SCFH. He tries to readjust the flow rate on the flowmeter, but still cannot get the specified 5 SCFH, so he adjusts the pressure of the pressure regulator upward until he can get the 5 SCFH flow. This results in doing the calibration with a pressure on the cell, for example, of 2 PSI (approximately 56 inches of water column). When he removes his calibration gases, and the probe sensing cell returns to the normal duct pressure of -1 inch of water column, the probe will be reading low by approximately 0.5% O<sub>2</sub>:

- 56 inches H<sub>2</sub>O pressure during calibration = 12% of reading shift (56 in H<sub>2</sub>O / 7 inH<sub>2</sub>O x 1.5% = 12%)
- If normal process O<sub>2</sub> readings are 4% O<sub>2</sub> then 4 x 0.12 = 0.48 % O<sub>2</sub> shift downwards (3.52% O<sub>2</sub>)

Although instruction manuals are clear in warning against this situation, it still occurs.

The new Plugged Diffuser Diagnostic in the 6888Xi electronics operates on the principle of measuring the "return to process" time during the calibration purge cycle (after the second calibration gas is removed). The return to process time measurement is used to calculate a diffuser response time (Diff T90) and to generate a warning to the user when the return to process time has exceeded 75% of the configured purge time. Default purge time is 300 seconds, but it's important for the user to configure the actual purge time for their process conditions. A purge time that is too long will prevent a plugged diffuser alarm from triggering until the diffuser pluggage is very bad. If the purge time is set too short, and probe has not fully returned to the process reading after the configured purge time expires, then the process reading will be in error due to test gas not being fully purged from the sensing cell area. As the diffuser becomes more plugged, the time to fully purge the sensing cell area of calibration test gas will increase.

The plugged diffuser feature works best with an automatic calibration system, where the probe electronics knows the exact timing of the solenoid gas switching. The diagnostic will also work for manual calibrations by detecting millivolt changes at the sensing cell during the stop gas phase of the calibration, when the second calibration gas has been disconnected.

In addition to providing a warning of possible diffuser pluggage, this feature can also be used to minimize the usage of calibration test gas and the time to perform a calibration. This capability is enabled by configuring the Auto Advance Cal parameter. When Auto Advance Cal is enabled, the plugged diffuser diagnostic will advance an automatic calibration when the readings for test gasses and the process measurement have become stable. By doing this, the amount of time that test gasses flow and purge are kept to a minimum.

The rate method is recommended for the plugged diffuser diagnostic. The rate method should work best for most applications, however if the diagnostic generates warnings with a new probe and/or diffuser, it may be necessary to switch the detection method to proximity.

By default, the Auto Advance Cal feature is disabled. Enabling Auto Advance Cal minimizes test gas usage and calibration time. When using the Auto Advance Cal feature, it is recommended using the default settings for gas time and purge time configuration (300 seconds).

A "Diffuser Warning" alarm will be generated within the 6888Xi if the diagnostic detects a variety of problems related to measuring the "return to process" time. To determine the exact cause for the Diffuser Warning alarm it is necessary to look at the Diffuser Warn parameter. See the Parameter Descriptions for a description of all possible Diffuser Warning indications in the Diff

Warn parameter.

The most important Diffuser Warning indication is “Diffuser Plugging” which is triggered if the time to return to process reaches greater than 75% of the configured purge time. If using the default purge time of 300 seconds, the warning will be generated when the plugging diffuser increases the actual purge time to 225 seconds. The purge time may be configured to a larger value if desired to stop the warning from occurring after future calibrations. Once the diffuser plugs enough to increase the actual purge time to 75% of the new configured value, the warning will start appearing again. Once the warning has occurred, it can be cleared by acknowledging the alarm. Note that if the configured purge time is set shorter than the actual purge time determined by the diagnostic, the Diffuser Warning indication will typically be “Purge End Premature.”

Also note that the Diffuser Warning alarm will never cause the O2 output signal to go to a “fail” condition (typically 3.5 mA).

The plugged diffuser diagnostic parameters are located in two separate locations in the 6888Xi menu.

- Setup parameters are located at: Menu\Detailed Setup\Calibration\Diffuser
- Diagnostic results parameters are located at: Menu\Calibration\Diffuser

Each parameter is described below:

#### **Menu\Detailed Setup\Calibration\Diffuser\Plugged Diffuser**

- Disabled – The plugged diffuser diagnostic is disabled.
- Rate – The plugged diffuser diagnostic is enabled with the rate mode algorithm. With this mode, the “returned to process” is indicated by the process reading having a small rate of change. This mode will function correctly even if the process is likely to be different at the end of the calibration than at the beginning. This is the default and recommended mode of operation.
- Proximity – The plugged diffuser diagnostic is enabled with the proximity mode algorithm. With this mode, the “return to process” is indicated when the process reading returns close to the value that it had when the calibration was started. This mode will function correctly when the process reading is stable throughout the calibration.
- Rate & Prox. – The plugged diffuser diagnostic is enabled with both Rate and Proximity mode algorithms. With this mode, the “return to process” is indicated when both the Rate and Proximity criteria are met.

#### **Menu\Detailed Setup\Calibration\Diffuser\Auto Advance Cal**

- Yes – Enables the Auto Advance Cal option to sequence an automatic calibration system. If an automatic calibration system is used, test gases will be switched automatically once the readings settle out rather than waiting for the configured gas time to expire. If manual calibration gas switching is used, the technician will be prompted to switch gases. In either case, the purge time will be ended automatically once the process reading has settled rather than wait for the configured purge time to expire.
- No – The Auto Advance Cal option is disabled. Test gas time and purge time will always follow the configured value.

#### Menu\Calibration\Diffuser\Diff Diagnostics

- Process – This is the sensor voltage output value at the start of the calibration. For the “Proximity” and “Rate&Prox” modes of the plugged diffuser diagnostic algorithm, it will be used to determine when the sensor has returned to the process measurement.
- O<sub>2</sub> – The real-time sensor voltage output value during calibration .
- Step – The current step of the calibration process.
- Step Time – The time remaining for the current calibration step.
- Diag Step – The current step of the plugged diffuser diagnostic algorithm.
- Init Response – The time for the Initial response of the cell after the calibration test gas is applied. Applies only when automatic calibration sequencing is utilized (as opposed to manually applying calibration test gasses).
- Process Resp – Initial response back to the process after the calibration test gas is removed (Tinitial). Applies only when automatic calibration sequencing is utilized (as opposed to manually applying calibration test gasses).
- Rtn Process – Return to process time (Tfinal) which is also the actual purge time. This may also be defined as the time it takes to get back to the initial "process" reading, or the time for the "rate" of the sensor output change to reach near zero, or both depending on which mode of the diagnostic has been enabled.
- O2 Rate Change – The rate of change of the O2 sensor output in mV/sec. This is used to determine when calibration test gasses and the process measurement have settled.

#### Menu\Calibration\Diffuser\Diff T90

- 90% of the Rtn Process time. This is a quantitative measure of the diffuser pluggage.

#### Menu\Calibration\Diffuser\Purge Time %

- The plugged diffuser diagnostic operates during the purge cycle (the time after the last calibration test gas is removed to give the process gas time to replace the calibration test gas in the sensing cell). Purge time % is the return to process time as a % of the configured Purge Time.

#### Menu\Calibration\Diffuser\Diff Warn

- None – This Diff Warn result will not produce a Diffuser Warning alarm. This result indicates that the diffuser diagnostic has not detected anything to report to the user. This is also the result after a power on reset or after acknowledging the Diffuser Warning alarm.
- Gas 1 no detect – Gas 1 was not detected at the sensing cell, indicating that Gas 1 is not flowing or the Gas 1 calibration test gas is very close to the actual process value.
- Gas 2 no detect – Gas 2 was not detected at the sensing cell, possibly indicating that Gas 2 is not flowing (with a significantly plugged diffuser) or the Gas 2 calibration test gas value is nearly the same as Gas 1.
- Gas 1 unstable- The Gas 1 reading did not settle within the Gas Flow Time.
- Gas 2 unstable – The Gas 2 reading did not settle within the Gas Flow Time.
- Process No Detect – The process gas was not detected during the purge cycle, possibly indicating that Gas 2 is not flowing or the Gas 2 calibration test gas is very close to the actual process value.

- Purge End Premature – This indicates that the configured Purge Time expired prior to the diagnostic algorithm determining that the sensing cell is completely returned to the process reading. This would occur primarily with the Rate mode algorithm.
- Fail Reach Process – This indicates that the configured Purge Time expired prior to the diagnostic algorithm reaching the process reading that was indicated at the start of the calibration. This would occur primarily with the Proximity mode algorithm.
- Diffuser Plugging – This warning is generated when Purge Time % has reached 75% indicating a near term risk that the configured purge time could expire before the process value is reached after a calibration purge.
- Constant Shifting – This indicates that the calibration constant is trending negative over an extended period of time which could also indicate that calibration test gas is causing excessive pressurization of the sensing cell during the calibration.

## 4.4 System parameter descriptions

Among the parameters available through the 6888Xi and 375/475 Field Communicator menus are a number of "System Parameters". The system parameters define variables that configure the 6888Xi in the transmitter system. System parameters are described in Table 3-4.

## 4.5 Probe parameter descriptions

Among the parameters available through the 6888Xi and 375/475 Field Communicator menus are a number of "Probe Parameters". The probe parameters define variables that configure a specific probe in the transmitter system. Probe parameters are described in Table 3-5.

## 4.6 Operation via HART/Asset Management Solutions (AMS) software

The 375/475 Field Communicator is a handheld communications interface device. It provides a common communications link to all microprocessor-based instruments that are HART compatible. The handheld communicator contains a liquid crystal display (LCD) and 21 keys. A pocket-sized manual, included with the 375/475 Field Communicator, details the specific functions of all the keys.

The 375/475 Field Communicator accomplishes its task using a frequency shift keying (FSK) technique. With the use of FSK, high-frequency digital communication signals are superimposed on the 6888Xi's 4-20 mA current loop. The 375/475 Field Communicator does not disturb the 4-20 mA signal, since no net energy is added to the loop.

### NOTE

**The 375 Field Communicator must be upgraded to System Software 2.0 with Graphic License for operation with the 6888Xi. The AMS software must be upgraded to AMS 8.0 or above for operation with the 6888Xi.**

**Contact Emerson's Global Service Center (GSC) at 1-800-833-8314 to upgrade the 375 Field Communicator software to System Software 2.0 with Graphic License.**



Table 4-4. System Parameters (1 of 3)

CPU	Parameter Name	Units	Description
Y	Active Alarms	--	Current Alarms
Y	Version	--	Software version number for the User Interface board
Y	Build Num	--	Software build number for the User Interface board
Y	Restart Count	--	Device restarts counter for the User Interface board
Y	Tag	--	System Tag: Up to 8 characters long.
Y	Num I/O Board	--	Number of I/O Board: 1 or 2. Default to 1 I/O board.
Y	Probe Count		Number of probes per I/O board. Default to 1 probe per I/O board. Configure to more than 1 probe per I/O board is reserved for future release.
Y	Dev Type		Device Type. Default to 6888-O2.
Y	One-Probe Format Line1, Center	--	Main display: Line 1 data for one probe configuration: 0 displays PV (O <sub>2</sub> ) 1 displays SV (O <sub>2</sub> Temp)
Y	One-Probe Format Line2, Center	--	Main display: Line 2 data for one probe configuration: 0 displays PV (O <sub>2</sub> ) 1 displays SV (O <sub>2</sub> Temp)
Y	One-Probe Format Line3, Left	--	Main display: Line 3 left hand side data for one probe configuration: 0 displays PV (O <sub>2</sub> ) 1 displays SV (O <sub>2</sub> Temp) 2 displays TV (Cell Imp) 3 displays 4V (Cell mV) 4 displays CJC Temp 5 displays AO 6 displays OP Mode 7 displays Tag
Y	One-Probe Format Line 3, Right	--	Main display: Line 3 right hand side data for one probe configuration: 0 displays PV (O <sub>2</sub> ) 1 displays SV (O <sub>2</sub> Temp) 2 displays TV (Cell Imp) 3 displays 4V (Cell mV) 4 displays CJC Temp 5 displays AO 6 displays OP Mode 7 displays Tag
Y	One-Probe Format Line4, Left	--	Main display: Line 4 left hand side data for one probe configuration: 0 displays PV (O <sub>2</sub> ) 1 displays SV (O <sub>2</sub> Temp) 2 displays TV (Cell Imp) 3 displays 4V (Cell mV) 4 displays CJC Temp 5 displays AO 6 displays OP Mode 7 displays Tag
Y	One-Probe Format Line4, Right	--	Main display: Line 4 right hand side data for one probe configuration: 0 displays PV (O <sub>2</sub> ) 1 displays SV (O <sub>2</sub> Temp) 2 displays TV (Cell Imp) 3 displays 4V (Cell mV) 4 displays CJC Temp 5 displays AO 6 displays OP Mode 7 displays Tag

**Table 4-4. System Parameters (2 of 3)**

CPU	Parameter Name	Units	Description
Y	Two-Probe Format Line1, Center	--	Main display: Line 1 data for two probe configuration: 0 displays PV (O2) 1 displays SV (O2 Temp) Line 1 & Line 3 are dedicated for probe 1 in a two probe configuration.
Y	Two-Probe Format Line2, Center	--	Main display: Line 2 data for two probe configuration: 0 displays PV (O2) 1 displays SV (O2 Temp) Line 2 & Line 4 are dedicated for probe 2 in a two probe configuration.
Y	Two-Probe Format Line3, Left	--	Main display: Line 3 left hand side data for two probe configuration: 0 displays PV (O2) 1 displays SV (O2 Temp) 2 displays TV (Cell Imp) 3 displays 4V (Cell mV) 4 displays CJC Temp 5 displays AO 6 displays OP Mode 7 displays Tag Line 1 & Line 3 are dedicated for probe 1 in a two probe configuration.
Y	Two-Probe Format Line3, Right	--	Main display: Line 3 right hand side data for two probe configuration: 0 displays PV (O2) 1 displays SV (O2 Temp) 2 displays TV (Cell Imp) 3 displays 4V (Cell mV) 4 displays CJC Temp 5 displays AO 6 displays OP Mode 7 displays Tag Line 1 & Line 3 are dedicated for probe 1 in a two probe configuration.
Y	Two-Probe Format Line4, Left	--	Main display: Line 4 left hand side data for two probe configuration: 0 displays PV (O2) 1 displays SV (O2 Temp) 2 displays TV (Cell Imp) 3 displays 4V (Cell mV) 4 displays CJC Temp 5 displays AO 6 displays OP Mode 7 displays Tag Line 2 & Line 4 are dedicated for probe 2 in a two probe configuration.
Y	Two-Probe Format Line4, Right	--	Main display: Line 4 right hand side data for two probe configuration: 0 displays PV (O2) 1 displays SV (O2 Temp) 2 displays TV (Cell Imp) 3 displays 4V (Cell mV) 4 displays CJC Temp 5 displays AO 6 displays OP Mode 7 displays Tag Line 2 & Line 4 are dedicated for probe 2 in a two probe configuration.
Y	Revert Time	min	The period of time the display to revert back to the Main Display without button activity.
Y	Language	--	Supported languages: 0 displays English 1 displays Spanish 2 displays German

Table 4-4. System Parameters (3 of 3)

CPU	Parameter Name	Units	Description
Y	Contrast	--	Display contrast. (120-220)
Y	Password	--	Xi Password: 4 numeric characters.
Y	Enable Password	--	Enable password protection. (No/Yes)
Y	Flash Alarm	--	Turn off/on the flashing on the main display when alarms occurred. (No/Yes)
N	Version	--	I/O board software version.
N	Checksum	--	I/O board software checksum.
N	IOB SN	--	I/O board serial number. Use this number for licensed feature code generation.
N	Features	--	Available advanced licensed features for the I/O board. ON: Feature supported OFF: Feature not supported
N	Factory Mode	--	I/O board factory mode (Always OFF, internal use only)
N	Resource – Analog Output	--	I/O board analog output resource mapping. One for each probe: Index 0x00000001 contains IOB AO Index 0x00000002 contains TX AO
N	Resource - Auto Cal	--	I/O board auto calibration resource mapping. One for each probe: Index 0x00000100 means SPS
N	Resource - Relay 1	--	I/O board's relay 1 resource mapping. One for each probe: Index 0x00010000 indicates IOB RELAY 1
N	Resource - Relay 2	--	I/O board's relay 2 resource mapping. One for each probe: Index 0x02000000 indicates IOB RELAY 2

**Table 4-5. Probe Parameters (1 of 4)**

TX	IOB	Parameter Name	Unit	Description
Y	Y	O2	%	Current oxygen concentration value (O2 %). The value should reflect the last good O2 value if it is in the "Lock" state during calibration.
Y	Y	O2 Temp	°C	Current O2 sensor temperature.
Y	Y	CJC Temp	°C	Current cold junction temperature.
N	Y	Board Temp	°C	Current electronic temperature measured at the I/O board.
Y	Y	O2 Cell	mV	Raw mV value for O2 sensor.
N	Y	T/C Volt	mV	O2 T/C voltage.
Y	Y	Cell Imp	ohm	Cell impedance/sensor resistance measured.
Y	Y	Heater	V	Heater voltage.
N	Y	Bottle Pressure1	psi	Gas 1 bottle pressure. (Valid if device is configured for HSPS autocal.)
N	Y	Bottle Pressure2	psi	Gas 2 bottle pressure. (Valid if device is configured for HSPS autocal.)
N	Y	Cell Pressure1	in H2O	Cell pressure measured while applying gas 1. (Valid if device is configured for HSPS autocal.)
N	Y	Cell Pressure2	in H2O	Cell pressure measured while applying gas 2. (Valid if device is configured for HSPS autocal.)
Y	Y	O2 AO	mA	Analog output value represents the O2 concentration measurement.
N	Y	O2 AO %	%	Analog output percentage for O2 AO.
Y	Y	O2 Temp Max	°C	This is the highest O2 sensor temperature reached since last reset.
Y	Y	O2 Temp Max Time	Days ago	Time stamp of the highest O2 sensor temperature reached since last reset.
Y	Y	Temperature   CJC Max	°C	This is the highest temperature reached at the cold junction since last reset.
Y	Y	Temperature   CJC Max Time	Days ago	Time stamp of the highest temperature reached at the cold junction since last reset.
N	Y	Temperature   Board Max	°C	This is the highest temperature reached at the IO board since last reset.
N	Y	Temperature   Board Max Time	Days ago	Time stamp of the highest temperature reached at the IO board since last reset.
Y	Y	Voltage   Heater Max	°C	This is the highest heater voltage reached since last reset.
Y	Y	Voltage   Heater Max Time	Days ago	Time stamp of the highest heater voltage reached since last reset.
Y	Y	Voltage   Cell Max	°C	This is the highest cell voltage reached since last reset.
Y	Y	Voltage   Cell Max Time	Days ago	Time stamp of the highest cell voltage reached since last reset.
N	Y	Ramp Rate   Heater Max	°C	This is the highest heater ramp rate reached since last reset.
N	Y	Ramp Rate   Heater Max Time	Days ago	Time stamp of the highest heater ramp rate reached since last reset.
Y	Y	OP Mode	--	Device operating mode: PO=Power up; WU=Warm Up (analog output is railed); NM=Normal operation; CA=Calibrating (analog output can be tracking or locked at last good value based on "AO Tracks" configuration); AL=Alarm detected (recoverable); SF=Alarm detected (non-recoverable)
Y	Y	Active Alarms	--	Current Alarms (See Section 4, Troubleshooting)
Y	Y	Device	--	Alarm state
Y	Y	Failed	--	Alarm state: On/Off NV Memory Fail, Board Temp High, Factory Mode, Heater Ramp Rate

**Table 4-5. Probe Parameters (2 of 4)**

<b>TX</b>	<b>IOB</b>	<b>Parameter Name</b>	<b>Unit</b>	<b>Description</b>
Y	Y	Maintenance 1	--	Alarm state: On/Off O2 Sensor Open, O2 T/C Open, O2 Temp Low, O2 Temp High, O2 T/C Shorted, O2 T/C Reversed, Heater Failure, Burner Flameout
Y	Y	Maintenance 2	--	Alarm state: On/Off Xmtr Disconnect, Cal Recommended, Cal Failed, Cell Imp High, Probe Mismatch
Y	Y	Advisory	--	Alarm state: Cal Changed, Htr Volt Low, Probe Changed, Low O2, Diffuser Warning
N	Y	Previous Alarms	--	Previous Alarms (See Section 4, Troubleshooting)
N	Y	Ack Alarm Time	Days ago	Time stamp of the previous alarms last acknowledged.
Y	Y	Duty Cycle	--	O2 heater duty cycle. Value between 0 and 1.
Y	Y	O2 Temp SP	°C	PID temperature set point
Y	Y	Heater Ramp Rate	°C/s	Heater ramp rate calculated in degree C per second.
Y	Y	Operating Status	--	Device configuration: On/Off Factory Mode, Flame Status (IO Board DIP Switch setting), Auto Cal Device, Relay 1 Device, Relay 2 Device, AO Device
N	Y	I/O States 1	--	I/O state: On/Off Gas 1 Solenoid, Gas 2 Solenoid
N	Y	I/O States 2	--	I/O state: On/Off Flame Status In, Factory Mode, Relay1 Out, Relay2 Out, SPS In, SPS Out
Y	Y	Xmtr EE Val	--	Transmitter board nonvolatile memory diagnostic.
N	Y	IOB EE Val	--	I/O board nonvolatile memory diagnostic.
Y	Y	Xmtr Restart	--	Software restarts count for the Transmitter.
N	Y	IOB Restart	--	Software restarts count for the IO board.
Y	Y	HART   Device Rev	--	HART Device Revision number.
Y	Y	Transmitter   Version	--	Software version number for the Transmitter.
N	Y	I/O Board   Version	--	Software version number for the I/O board
Y	Y	Tag	--	Device tag: Up to 8 characters long.
Y	Y	Serial Number	--	Probe serial number.
Y	Y	Device ID	--	Unique Device ID number. (HART)
Y	Y	PV	--	Primary variable assignment: O2 (HART)
Y	Y	SV	--	Secondary variable assignment: O2 Temp (HART)
Y	Y	TV	--	Third variable assignment: Cell Imp (HART)
Y	Y	4V	--	Fourth variable assignment: O2 Cell (HART)
N	Y	Poll Address	--	I/O board polling address
Y	Y	Xmtr Address	--	Transmitter board polling address
N	Y	T90 Filter	sec	Analog output T90 time. It represents the time to take a step change in oxygen to reach 90% of the final value at the filter output.
N	Y	Low O2 Alm SP	%	Low O2 alarm threshold.
N	Y	O2 Cell Ref	%	O2 sensor reference gas percentage. It allows using a sensor reference gas other than air. (Parameter for Programmable Reference feature.)
N	Y	High Temp Alm SP	°C	High temperature alarm threshold. (Parameter for Extended Temperature feature.)
N	Y	Heater SP	--	Heater set point. (Parameter for Extended Temperature feature.) 0 = Normal (736C), 1 = Low (550C)

Table 4-5. Probe Parameters (3 of 4)

TX	IOB	Parameter Name	Unit	Description
N	Y	Heater Latch Off	--	Heater latch Off. (Parameter for Extended Temperature feature.) No = The heater will turn back on once the temperature falls below the heater set point Yes = The heater will not turn back on once the temperature falls below the heater set point
N	Y	Features	--	Advanced software features: 0 = Stoichiometer, 1 = Prog Reference, 2 = Extended Temp, 4 = Diffuser Warning
Y	Y	O2 LRV	%	Primary variable (O2 %) lower range value.
Y	Y	O2 URV	%	Primary variable (O2 %) upper range value
N	Y	AO Range	--	Analog output polarity: 0 = 4-20mA, 1 = 20-4mA
Y	Y	Alarm Level	--	O2 alarm level: 0 = 3.5 mA, 1 = 21.1mA
N	Y	Relay 1	--	Alarm Relay 1 mode: 0 = Unit alarm, 1 = Low O2, 2 = Cal Recommended, 3 = In Calibration
N	Y	Relay 2	--	Alarm Relay 2 mode: 0 = Unit alarm, 1 = Low O2, 2 = Cal Recommended, 3 = In Calibration, 4 = Heater Relay (Default)
N	Y	AO Track	--	Analog output track O2 sensor measurement during a calibration: No/Yes
N	Y	Tol Check	--	Enable/Disable tolerance check during calibration: No/Yes
N	Y	Cal Recommend	--	Enable/Disable calibration recommended alarm: No/Yes
N	Y	Cal Acknowledge	--	Enable/Disable calibration acknowledge before update calibration constants: No/Yes
Y	Y	Cal Gas 1	%	Test Gas 1 value. This is the actual value of the gas being applied during the Test Gas 1 phase of a calibration.
Y	Y	Cal Gas 2	%	Test Gas 2 value. This is the actual value of the gas being applied during the Test Gas 2 phase of a calibration.
Y	Y	Gas Time	sec	Test Gas application time. This is the length of time test gases are applied to the O2 probe during low or high Test Gas phase of a calibration.
Y	Y	Purge Time	sec	Test Gas purge time. This is the length of time before the output will be returned to the process reading after a calibration.
N	Y	Plugged Diffuser	--	Enable Plugged Diffuser functionality: (Parameter for Diffuser Warning feature.) 0 = Disable, 1 = Rate, 2 = Proximity, 3 = Rate & Prox
N	Y	Auto Advance Cal	--	Auto advance calibration state machine when it detects that the cell response has stabilized during test gas flow and purge: No/Yes (Parameter for Diffuser Warning feature.)
N	Y	Enable Auto Cal	--	Enable/disable automatic calibration: No/Yes
N	Y	Start on Cal Rec	--	Start automatic calibration on Cal Recommended state: No/Yes
N	Y	Cal Interval	hr	Automatic calibration interval. The number 9999 disable the automatic timed calibration.
N	Y	Next Cal Time	hr	Time remaining until the next automatic periodic calibration. The number 9999 disable the next automatic timed calibration.
N	Y	Resource   Analog Output		I/O board analog output resource mapping. One for each probe: 0x00000001 is for IOB AO 0x00000002 is for TX AO
N	Y	Resource   Auto Cal		I/O board auto calibration resource mapping. One for each probe: 0x00000100 is for SPS
N	Y	Resource   Relay 1		I/O board's relay 1 resource mapping. One for each probe: 0x00010000 is for IOB RELAY 1
N	Y	Resource   Relay 2		I/O board's relay 2 resource mapping. One for each probe: 0x02000000 is for IOB RELAY 2

**Table 4-5. Probe Parameters (4 of 4)**

<b>TX</b>	<b>IOB</b>	<b>Parameter Name</b>	<b>Unit</b>	<b>Description</b>
Y	Y	Slope	mV/Dec	Current calibration slope. This is the slope value that was calculated as a result of the last successful calibration.
Y	Y	Constant	mV	Current calibration constant. This is the constant value that was calculated as a result of the last successful calibration.
Y	Y	Impedance	ohm	Cell Impedance. This is the sensor resistance that was calculated as a result of the last successful calibration.
Y	Y	Time	Days ago	Time stamp of the last successful calibration.
Y	Y	Cal Logs   Slope	mV/Dec	Previous calibration slope. There are ten calibration results. 1 is the most recent and 10 is the least recent calibration slope
Y	Y	Cal Logs   Constant	mV	Previous calibration constant. There are ten calibration results. 1 is the most recent and 10 is the least recent calibration constant.
Y	Y	Cal Logs   Impedance	ohm	Previous Cell Impedance. This is the sensor resistance that was calculated as a result of previous successful calibration. . There are ten calibration results. Index 1 is the most recent and Index 10 is the least recent sensor resistance measured.
Y	Y	Cal Logs   Time	Days ago	Time stamp of the previous successful calibration. There are ten calibration time stamp. Index 1 is the most recent and Index 10 is the least recent time stamp.
N	Y	Bad Slope	mV/Dec	Failed calibration slope.
N	Y	Bad Constant	mV	Failed calibration constant.
Y	Y	Cal Result	--	Calibration result: 0 = None, 1 = Success, 2 = Failed Constant, 3 = Failed Slope, 4 = Failed Temperature, 5 = Gas 1 Tolerance Error, 6 = Gas 2 Tolerance Error, 7-10 (future), 11 = AutoCal No Resp, 12 = AutoCal OutofSync, 13 = AutoCal Abort, 14 = No Solenoid, 15 = WarmUp Abort, 16 Alarm Abort
N	Y	Delta Imp	--	Delta impedance since last calibration.
N	Y	Cal Step	--	This represents the step of the calibration cycle is in: 0 = Idle, 1 = Reserved, 2 = Apply Gas 1, 3 = Flow Gas 1, 4 = Read Gas 1, 5 = Apply Gas 2, 6 = Flow Gas 2, 7 = Read Gas 2, 8 = Cal Abort, 9 = Stop Gas, 10 = Purge
N	Y	Time Remain	sec	Time remaining in the present calibration cycle state.
N	Y	Process	mV	Cell mV reading just prior to start of calibration. (Diagnostic parameter for Diffuser Warning feature.)
N	Y	Diag State	--	The state of the Diffuser Warning state machine: (Diagnostic parameter for Diffuser Warning feature.) 0 = Idle, 1 = Wait Gas 1, 2 = Stable Gas 1, 3 = Read Gas 1, 4 = Wait Gas 2, 5 = Stable Gas 2, 6 = Read Gas 2, 7 = Wait Process, 8 = Rtn Process
N	Y	Init Resp	sec	The time it takes for the first calibration test gas to reach the sensor cell after the solenoid is energized. (Diagnostic parameter for Diffuser Warning feature.)
N	Y	Process Resp	sec	The time it takes to see the initial response of the process after the gas 2 solenoid is turned off. (Diagnostic parameter for Diffuser Warning feature.)
N	Y	Rtn Process	sec	The time it takes from the initial response of the process until the process value has stabilized close to the value of the process when the calibration started. (Diagnostic parameter for Diffuser Warning feature.)
N	Y	O2 Rate Change	mV/s	The O2 cell mV rate of change. (Diagnostic parameter for Diffuser Warning feature.)
N	Y	Diff T90	sec	The time it takes from the gas-2 solenoid is turned off to return to 90% of the process when the calibration started. (Diagnostic parameter for Diffuser Warning feature.)
N	Y	Purge Time %	%	The percent of purge time used. This parameter can be used to estimate amount of diffuser pluggage. (Diagnostic parameter for Diffuser Warning feature.)
N	Y	Diff Warn	--	The reason of the Diffuser Warning alarm: (Diagnostic parameter for Diffuser Warning feature.) 0 = None, 1 = Gas 1 No Detect, 2 = Gas 2 No Detect, 3 = Gas 1 Unstable, 4 = Gas 2 Unstable, 5 = Process No Detect, 6 = Purge End Premature, 7 = Fail Reach Process, 8 = Diffuser Plugging, 9 = Constant Shifting

FIGURE 4-5. 375/475 Field Communicator Connection at the 6888Xi

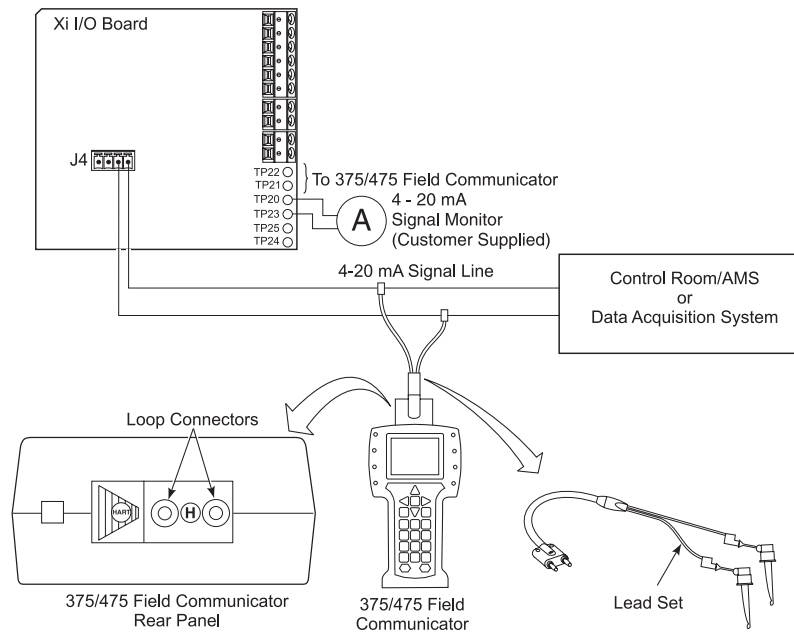

## 4.6.1 Field Communicator signal line connections

When working at the 6888Xi, the 375/475 Field Communicator can be connected directly to test points TP21 and TP22 on the 6888Xi I/O Board as shown in Figure 3-5. The AM+ and AM- test points are provided to monitor the 4-20 mA signal without breaking into the loop.

## 4.6.2 Field Communicator menu trees

Connect the 375/475 Field Communicator in the 6888Xi (6888Xi-to-DCS) 4-20 mA signal loop or to the 6888Xi terminals as shown in Figure 3-5 and refer to Figure 3-6 for the 375/475 Field Communicator 6888Xi menu tree.

## 4.7 Parameter setup

### 4.7.1 Test gas values

Use a Field Communicator or the 6888Xi to set test gas values for calibration.

When using the 6888Xi with an SPS4001B, the test gas values for Gas 1 and Gas 2 correspond with Lo Gas and Hi Gas, respectively. Care must be taken to ensure the test gas values are properly matched and the test gases are plumbed correctly to the SPS4001B. Failure to do so may cause errors on the calibration sequence or trigger an error if tolerance check is set on.



FIGURE 4-6. 375/475 Field Communicator 6888Xi Menu Tree (Sheet 1 of 4)

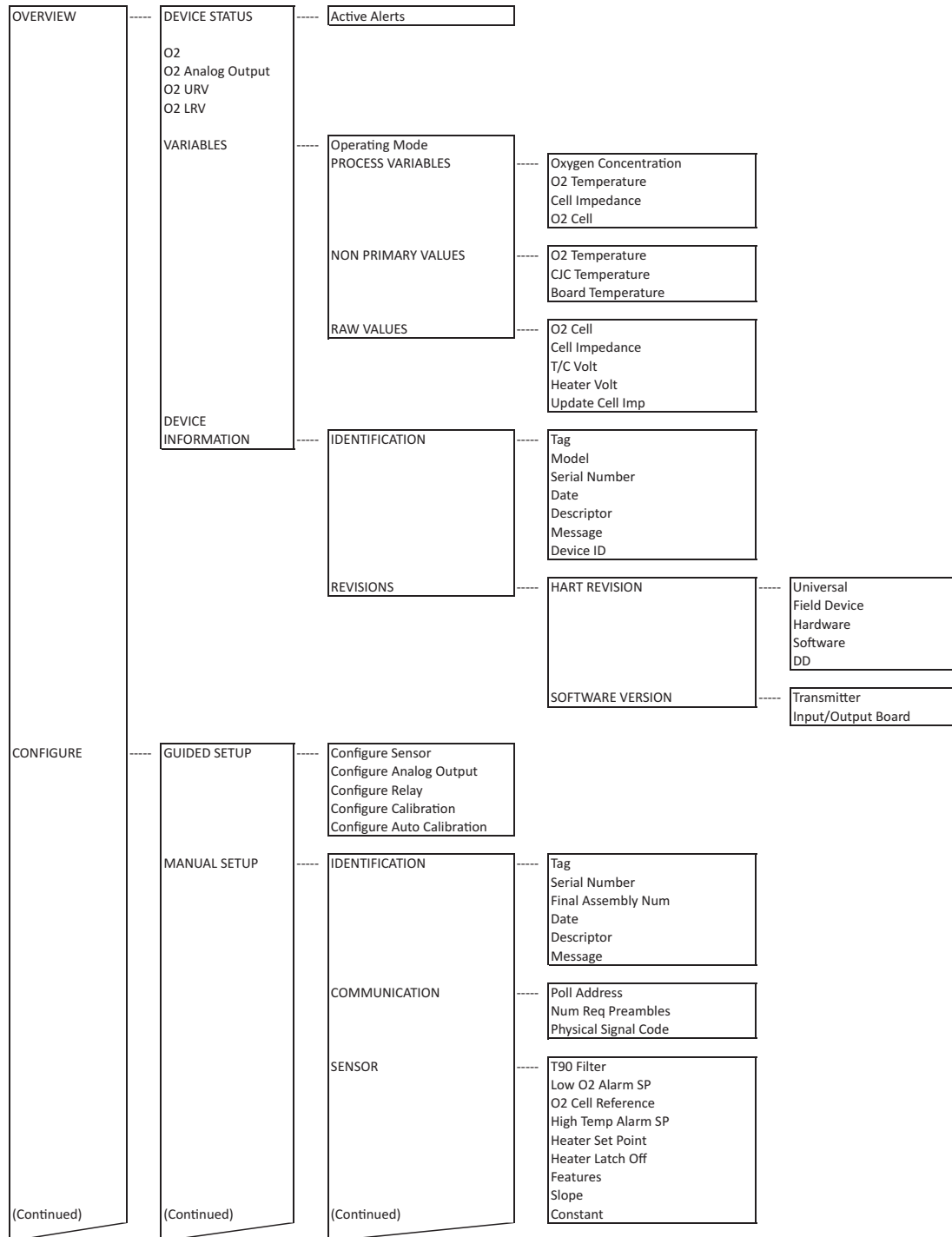

FIGURE 4-6. 375/475 Field Communicator 6888Xi Menu Tree (Sheet 2 of 4)

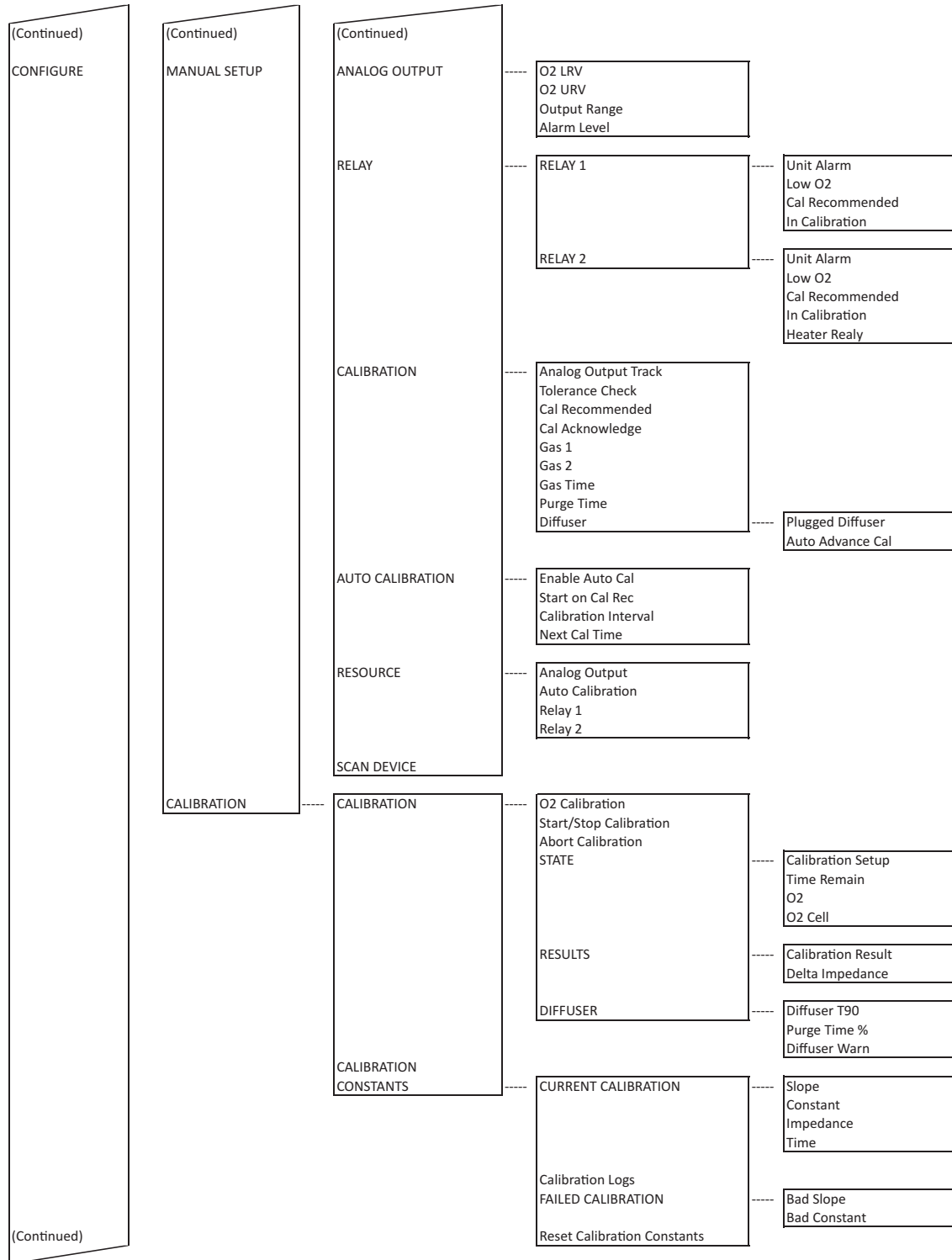

FIGURE 4-6. 375/475 Field Communicator 6888Xi Menu Tree (Sheet 3 of 4)

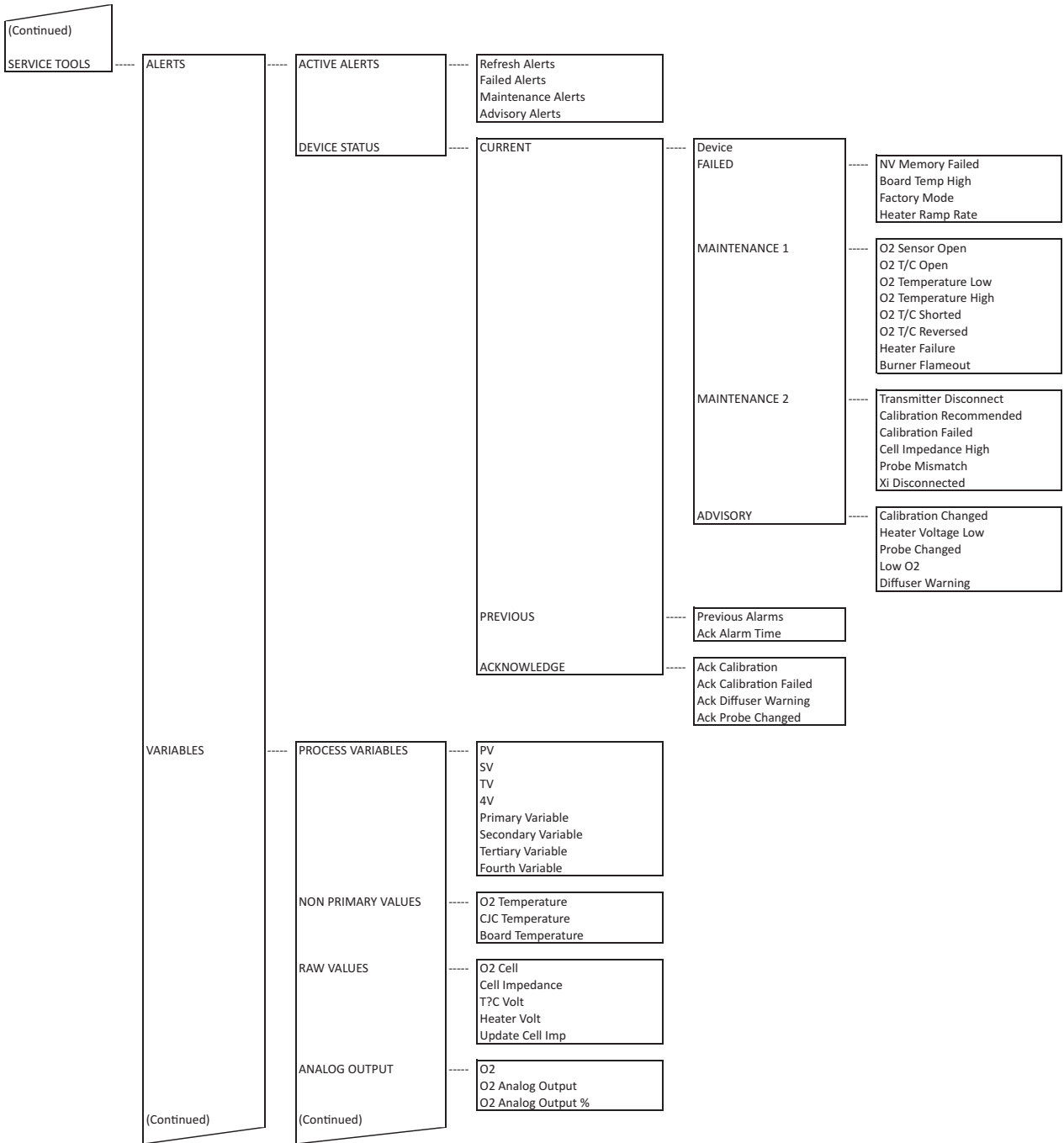
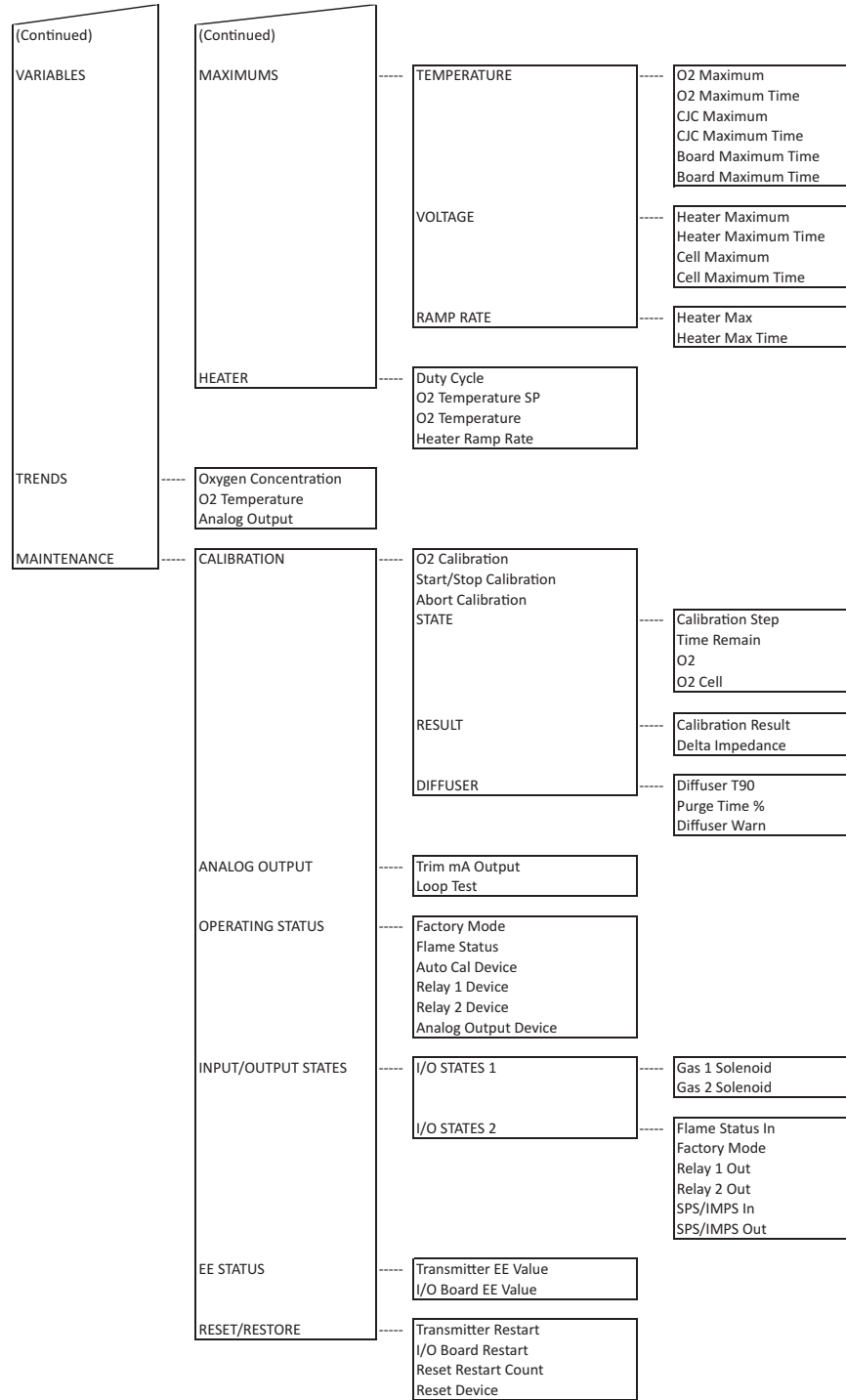

FIGURE 4-6. 375/475 Field Communicator 6888Xi Menu Tree (Sheet 3 of 4)



A 6888Xi shipped from the factory has test gas values for low and high set to 0.4% and 8.0% respectively. This same process must be performed any time an I/O Board is replaced.

#### **Setting Test Gas Values Using the 6888Xi Keypad/Display**

1. Press the MENU button repeatedly until the IOB1 Probe 1 menu displays.
2. From the main menu, select DETAILED SETUP then press ENTER.
3. From the DETAILED SETUP menu, select CALIBRATION then press ENTER.
4. From the CALIBRATION menu, select CAL GAS 1 then press ENTER.
5. Press the RIGHT arrow key to edit the value. Use the RIGHT and LEFT arrow keys to select the digit to edit, then the UP and DOWN arrow keys to change the value of the digit. Press ENTER to save the new value. Press the LEFT arrow key to return to the CALIBRATION menu.
6. From the CALIBRATION menu, select CAL GAS 2 then press ENTER. Repeat step 5 for calibration gas 2.
7. Press the EXIT key to return to the main menu.
8. Repeat steps 1 through 7 for PROBE 2 if configured for dual channel.

#### **Setting Test Gas Values Using Field Communicator in Manual Configure Mode**

1. Use the 375/475 Field Communicator to access the main HART menu.
2. From the main menu, select CONFIGURE.
3. From the CONFIGURE menu, select MANUAL SETUP.
4. From the MANUAL SETUP menu, select CALIBRATION.
5. From the CALIBRATION menu, select GAS 1.
6. Press the RIGHT arrow key to edit the gas value.
7. Use the stylus on the screen to enter the new gas value then press ENTER when finished.
8. Use the stylus on the screen to select SEND to update the 6888Xi.
9. Repeat steps 5 through 8 for GAS 2.

## 4.7.2 Test gas times

Use a Field Communicator or the 6888Xi to set test gas flow time and purge time for calibration.

A 6888Xi shipped from the factory has test gas flow time and purge time set to 300 seconds. This same process must be performed any time an I/O Board is replaced.

#### **Setting Test Gas Times Using the 6888Xi Keypad/Display**

1. Press the MENU button repeatedly until the IOB1 Probe 1 menu displays.
2. From the main menu, select DETAILED SETUP then press ENTER.
3. From the DETAILED SETUP menu, select CALIBRATION then press ENTER.
4. From the CALIBRATION menu, select GAS TIME then press ENTER.
5. Press the RIGHT arrow key to edit the value. Use the RIGHT and LEFT arrow keys to select the digit to edit, then the UP and DOWN arrow keys to change the value of the digit. Press ENTER to save the new value. Press the LEFT arrow key to return to the CALIBRATION menu.
6. From the CALIBRATION menu, select PURGE TIME then press ENTER. Repeat step 5 for purge time 2.
7. Press the EXIT key to return to the main menu.
8. Repeat steps 1 through 7 for PROBE 2 if configured for dual channel.

#### **Setting Test Gas Times Using Field Communicator in Manual Configure Mode**

1. Use the 375/475 Field Communicator to access the main HART menu.
2. From the main menu, select CONFIGURE.

3. From the CONFIGURE menu, select MANUAL SETUP.
4. From the MANUAL SETUP menu, select CALIBRATION.
5. From the CALIBRATION menu, select GAS TIME.
6. Press the RIGHT arrow key to edit the gas value.
7. Use the stylus on the screen keypad to enter the new gas value then press ENTER when finished.
8. Use the stylus on the screen to select SEND to update the 6888Xi.
9. From the CALIBRATION menu, select PURGE TIME.
10. Press the RIGHT arrow key to edit the gas value.
11. Use the stylus on the screen to enter the new gas value then press ENTER when finished.
12. Use the stylus on the screen to select SEND to update the 6888Xi.

### 4.7.3 Output tracking during calibration

Use a Field Communicator or the 6888Xi to set how the analog output value will function during calibration.

A 6888Xi shipped from the factory has the output tracking set to No, i.e. the analog output will hold the last value during the calibration cycle. This same process must be performed any time an I/O Board is replaced.

#### Setting Output Tracking Using the 6888Xi Keypad/Display

1. Press the MENU button repeatedly until the IOB1 Probe 1 menu displays.
2. From the main menu, select DETAILED SETUP then press ENTER.
3. From the DETAILED SETUP menu, select CALIBRATION then press ENTER.
4. From the CALIBRATION menu, select AO TRACK then press ENTER.
5. Press the RIGHT arrow key to edit the value.
  - No – The analog output will hold the last value during calibration
  - Yes – The analog output will track the actual measurement during calibrationUse the UP and DOWN arrow keys to change the value from NO to YES or YES to NO. Press ENTER to save the new value. Press the LEFT arrow key to return to the CALIBRATION menu.
6. Press the EXIT key to return to the main menu.
7. Repeat steps 1 through 6 for PROBE 2 if configured for dual channel.

#### Setting Output Tracking Using Field Communicator in Manual Configure Mode

1. Use the 375/475 Field Communicator to access the main HART menu.
2. From the main menu, select CONFIGURE.
3. From the CONFIGURE menu, select MANUAL SETUP.
4. From the MANUAL SETUP menu, select CALIBRATION.
5. From the CALIBRATION menu, select ANALOG OUTPUT TRACK.
6. Press the RIGHT arrow key to change the value from NO to YES or YES to NO.
  - No – The analog output will hold the last value during calibration
  - Yes – The analog output will track the actual measurement during calibration
7. Use the stylus on the screen to press ENTER when finished.
8. Use the stylus on the screen to select SEND to update the 6888Xi.

### 4.7.4 Tolerance check

Use a Field Communicator or the 6888Xi to set whether or not the measured calibration gas value is validated against the programmed value. If configured Yes, the 6888Xi will create an alarm if the measured value varies more than  $\pm 10\%$  from the programmed value. Also, when configured Yes, the 6888 must be calibrated using calibration gas 1 first then calibration gas 2 second and the gas

values must be set properly.

When using the 6888Xi with an SPS4001B, the test gas values for Gas 1 and Gas 2 correspond with Lo Gas and Hi Gas, respectively. Care must be taken to ensure the test gas values are properly matched and the test gases are plumbed correctly to the SPS4001B. Failure to do so may cause errors on the calibration sequence or trigger an error if tolerance check is set on.

A 6888Xi shipped from the factory has the tolerance check set to No. This same process must be performed any time an I/O Board is replaced.

#### Setting Tolerance Check Using the 6888Xi Keypad/Display

1. Press the MENU button repeatedly until the IOB1 Probe 1 menu displays.
2. From the main menu, select DETAILED SETUP then press ENTER.
3. From the DETAILED SETUP menu, select CALIBRATION then press ENTER.
4. From the CALIBRATION menu, select TOL CHECK then press ENTER.
5. Press the RIGHT arrow key to edit the value.
  - No – Tolerance Check active
  - Yes – Tolerance Check inactive

Use the UP and DOWN arrow keys to change the value from NO to YES or YES to NO. Press ENTER to save the new value. Press the LEFT arrow key to return to the CALIBRATION menu.
6. Press the EXIT key to return to the main menu.
7. Repeat steps 1 through 6 for PROBE 2 if configured for dual channel.

#### Setting Tolerance Check Using Field Communicator in Manual Configure Mode

1. Use the 375/475 Field Communicator to access the main HART menu.
2. From the main menu, select CONFIGURE.
3. From the CONFIGURE menu, select MANUAL SETUP.
4. From the MANUAL SETUP menu, select CALIBRATION.
5. From the CALIBRATION menu, select TOLERANCE CHECK.
6. Press the RIGHT arrow key to change the value from NO to YES or YES to NO.
  - No – Tolerance Check active
  - Yes – Tolerance Check inactive

Use the stylus on the screen to press ENTER when finished.
7. Use the stylus on the screen to select SEND to update the 6888Xi.

## 4.7.5 Alarm relay output configuration

The 6888Xi has two dry contact Form-C alarm relay output signals that can be configured in

**Table 4-3 - Alarm Relay Output Configurations**

Mode	Configuration
No Alarm	All modes set to OFF
Unit Alarm	The alarm output is configured for a Unit Alarm (i.e. any alarm that affects heater operation). These alarms are non-recoverable and require a power cycle or service to clear
Low O2	The alarm output is configured for Low O2 Alarm
Cal Recommended	The alarm output is configured for a Calibration Recommended Alarm
In Calibration	The alarm output is configured for an In Calibration indication
Heater Relay	The alarm output is configured for Flame Safety Interlock

multiple modes through the 6888Xi keypad display or the 375/475 Field Communicator. A list of modes is shown in Table 3-3. Each alarm relay output can be configured separately and one or all modes can be turned on in any combination.

If the 6888Xi is configured with the optional Flame Safety Interlock or for Traditional Architecture, Alarm 2 is preconfigured with "Heater Relay" and prewired to either the AC Relay Board or DR Board. In this condition the relay configuration cannot be changed to any other setting. If changes are attempted to be made, the 6888Xi will respond with an "Access Restricted" warning. If the 6888Xi is not configured with the optional Flame Safety Interlock, "Heater Relay" is not valid and cannot be chosen for Alarm 2.

#### **Configuring the Alarm Relays Using the 6888Xi Keypad/Display**

1. Press the MENU button repeatedly until the IOB1 Probe 1 menu displays.
2. From the main menu, select DETAILED SETUP then press ENTER.
3. From the DETAILED SETUP menu, select RELAY then press ENTER.
4. From the RELAY menu, select RELAY 1 then press ENTER.
5. From the RELAY 1 menu, use the UP and DOWN arrow keys to select the mode and the ENTER key to toggle the value from ON to OFF or OFF to ON. Relay modes are as follows:  
**Unit Alarm**  
**Low O2**  
**Cal Recommended**  
**In Calibration**
6. Press ENTER key to accept settings. When questioned, use the UP and DOWN arrow keys to select YES or NO to save configuration. Press ENTER to continue.
7. From the RELAY menu, select RELAY 2 then press ENTER.
8. From the RELAY 2 menu, use the UP and DOWN arrow keys to select the mode and the ENTER key to toggle the value from ON to OFF or OFF to ON. Relay modes are as follows:  
**Unit Alarm**  
**Low O2**  
**Cal Recommended**  
**In Calibration**  
**Heater Relay**
9. Press LEFT arrow key. When questioned, use the UP and DOWN arrow keys to select YES or NO to save configuration. Press ENTER to continue.
10. Press the EXIT key to return to the main menu.
11. Repeat steps 1 through 10 for PROBE 2 if configured for dual channel.

#### **Configuring the Alarm Relays Using Field Communicator in Manual Configure Mode**

1. Use the 375/475 Field Communicator to access the main HART menu.
2. From the main menu, select CONFIGURE.
3. From the CONFIGURE menu, select MANUAL SETUP.
4. From the MANUAL SETUP menu, select RELAY.
5. From the RELAY menu, select RELAY 1.
6. From the RELAY 1 menu, use the stylus on the screen to select the mode then either the ON or OFF buttons. Relay modes are as follows:  
**Unit Alarm**  
**Low O2**  
**Cal Recommended**



### **In Calibration**

Use the stylus on the screen to select ENTER, then SEND to update the 6888Xi.

7. From the RELAY menu, select RELAY 2.
8. From the RELAY 2 menu, use the stylus on the screen to select the mode then either the ON or OFF buttons. Relay modes are as follows:

#### **Unit Alarm**

#### **Low O<sub>2</sub>**

#### **Cal Recommended**

#### **In Calibration**

#### **Heater relay**

Use the stylus on the screen to select ENTER, then SEND to update the 6888Xi.

## 4.7.6 Analog output configuration

The analog output signal from the 6888Xi can be configured for the 4-20 mA range and fault condition.

A 6888Xi shipped from the factory has the analog outputs set to a 4 to 20 mA range with a 3.5 mA alarm level. This same process must be performed any time an I/O Board is replaced.

### **Configuring the Analog Output Using the 6888Xi Keypad/Display**

1. Press the MENU button repeatedly until the IOB1 Probe 1 menu displays.
2. From the main menu, select DETAILED SETUP then press ENTER.
3. From the DETAILED SETUP menu, select ANALOG OUTPUT then press ENTER.
4. From the ANALOG OUTPUT menu, select from the following parameters then press ENTER:
  - O<sub>2</sub> LRV – O<sub>2</sub> value at lower analog output value (0 mA or 4 mA)
  - O<sub>2</sub> URV – O<sub>2</sub> value at upper analog output value (20 mA)
  - AO Range – Range of analog output (0-20 mA or 4-20 mA)
  - Alarm Level – O<sub>2</sub> alarm level (3.5 mA or 21.1 mA)
5. Press the RIGHT arrow key to edit the value. Use the RIGHT and LEFT arrow keys to select the digit to edit, then the UP and DOWN arrow keys to change the value of the digit. Press ENTER to save the new value. Press the LEFT arrow key to return to the ANALOG OUTPUT menu.
6. Press the EXIT key to return to the main menu.
7. Repeat steps 1 through 6 for PROBE 2 if configured for dual channel.

### **Configuring the Analog Output Using Field Communicator in Manual Configure Mode**

1. Use the 375/475 Field Communicator to access the main HART menu.
2. From the main menu, select CONFIGURE.
3. From the CONFIGURE menu, select MANUAL SETUP.
4. From the MANUAL SETUP menu, select ANALOG OUTPUT.
5. From the ANALOG OUTPUT menu, select from the following parameters then press ENTER:
  - O<sub>2</sub> LRV – O<sub>2</sub> value at lower analog output value (0 mA or 4 mA)
  - O<sub>2</sub> URV – O<sub>2</sub> value at upper analog output value (20 mA)
  - Output Range – Range of analog output (0-20 mA or 4-20 mA)
  - Alarm Level – O<sub>2</sub> alarm level (3.5 mA or 21.1 mA)
6. Use the stylus on the screen keypad to enter the value then press ENTER when finished.
7. Use the stylus on the screen to select SEND to update the 6888Xi.

## 4.7.7 Autocalibration

If autocalibration is desired, the 6888Xi must be used with either an SPS 4001B. The 6888Xi must be properly configured before autocalibration can take place. Refer to the applicable SPS 4001B instruction manual for details on performing autocalibration. Refer to this section for details on manual calibration procedures.

A 6888Xi is shipped from the factory without autocalibration configured. This same process must be performed any time an I/O Board is replaced.

### Activating the Autocalibration Menu if not available

1. Apply power to 6888Xi.
2. Press MENU until the “System” menu appears.
3. Select CONFIGURE IOB.
4. Press the ENTER key to continue.
5. Select I/O BOARD 1. (Note: With a dual channel 6888Xi, either or both I/O boards may be reset and reconfigured.)
6. Press the ENTER key to continue.
7. Select RESET I/O BOARD. Press the ENTER key to continue.
8. When the reset menu appears, select FACTORY DEFAULTS. Press the ENTER key to continue.
9. At the SENSOR TYPE screen, select O2. Do not select CO as this option is reserved for future use. Press the ENTER key to continue.
10. At the DEVICE TYPE screen, select HART or FF (FOUNDATION Fieldbus), whichever applies.
11. At the AUTO CAL DEVICE screen, use the Up/Down keys to select the calibration method to be used.

The methods are defined as follows:

1. None - Manual calibration with the standard probe housing configuration
2. SPS - Automatic calibration with the standard probe housing configuration using the SPS4001B
3. Integral - Automatic calibration with the 6888A integral autocal probe housing configuration

### Configuring Autocalibration Using the 6888Xi Keypad/Display

1. Press the MENU button repeatedly until the IOB1 Probe 1 menu displays.
2. From the main menu, select DETAILED SETUP then press ENTER.
3. From the DETAILED SETUP menu, select AUTO CALIBRATION then press ENTER.
4. From the AUTO CALIBRATION menu, select ENABLE AUTO CAL then press ENTER.
5. Press the RIGHT arrow key to edit the value. Use the UP and DOWN arrow keys to change the value from NO to YES or YES to NO. Press ENTER to save the new value. Press the LEFT arrow key to return to the AUTO CALIBRATION menu.
6. Press the EXIT key to return to the main menu.
7. Repeat steps 1 through 6 for PROBE 2 if configured for dual channel.

### Configuring Autocalibration Using Field Communicator

1. Use the 375/475 Field Communicator to access the main HART menu.
2. From the main menu, select CONFIGURE.
3. From the CONFIGURE menu, select MANUAL SETUP.
4. From the MANUAL SETUP menu, select AUTO CALIBRATION.

5. From the AUTO CALIBRATION menu, select the ENABLE AUTOCAL parameter.
6. Press the RIGHT arrow key to edit. Use the stylus on the screen keypad to select YES or NO then press ENTER when finished.
7. Use the stylus on the screen to select SEND to update the 6888Xi.

## 4.7.8 Calibration recommended

The 6888Xi can be configured whether or not to announce a calibration recommended alarm. This alarm advises the user that the calibration is out of date and should be recalibrated.

A 6888Xi is shipped from the factory with the calibration recommended alarm enabled. This same process must be performed any time an I/O Board is replaced.

### **Configuring Calibration Recommended Using the 6888Xi Keypad/Display**

1. Press the MENU button repeatedly until the IOB1 Probe 1 menu displays.
2. From the main menu, select DETAILED SETUP then press ENTER.
3. From the DETAILED SETUP menu, select CALIBRATION then press ENTER.
4. From the CALIBRATION menu, select CAL RECOMMENDED then press ENTER.
5. Press the RIGHT arrow key to edit the value. Use the UP and DOWN arrow keys to change the value from NO to YES or YES to NO. Press ENTER to save the new value. Press the LEFT arrow key to return to the CALIBRATION menu.
6. Press the EXIT key to return to the main menu.
7. Repeat steps 1 through 6 for PROBE 2 if configured for dual channel.

### **Configuring Calibration Recommended Using Field Communicator in Manual Configure Mode**

1. Use the 375/475 Field Communicator to access the main HART menu.
2. From the main menu, select CONFIGURE.
3. From the CONFIGURE menu, select MANUAL SETUP.
4. From the MANUAL SETUP menu, select AUTO CALIBRATION.
5. From the AUTO CALIBRATION menu, select the START ON CAL REC parameter.
6. Press the RIGHT arrow key to edit. Use the stylus on the screen keypad to select YES or NO then press ENTER when finished.
7. Use the stylus on the screen to select SEND to update the 6888Xi.

## 4.7.9 Calibration acknowledged

The 6888Xi can be configured whether or not to allow the user to not accept a calibration.

A 6888Xi is shipped from the factory with the calibration acknowledged alarm disabled. This same process must be performed any time an I/O Board is replaced.

### **Configuring Calibration Acknowledged Using the 6888Xi Keypad/Display**

1. Press the MENU button repeatedly until the IOB1 Probe 1 menu displays.
2. From the main menu, select DETAILED SETUP then press ENTER.
3. From the DETAILED SETUP menu, select CALIBRATION then press ENTER.
4. From the CALIBRATION menu, select CAL ACKNOWLEDGE then press ENTER.
5. Press the RIGHT arrow key to edit the value. Use the UP and DOWN arrow keys to change the value from NO to YES or YES to NO. Press ENTER to save the new value. Press the LEFT arrow key to return to the CALIBRATION menu.
6. Press the EXIT key to return to the main menu.
7. Repeat steps 1 through 6 for PROBE 2 if configured for dual channel.

### Configuring Calibration Acknowledged Using Field Communicator in Manual Configure Mode

1. Use the 375/475 Field Communicator to access the main HART menu.
2. From the main menu, select CONFIGURE.
3. From the CONFIGURE menu, select MANUAL SETUP.
4. From the MANUAL SETUP menu, select CALIBRATION.
5. From the CALIBRATION menu, select the CAL ACKNOWLEDGE parameter.
6. Press the RIGHT arrow key to edit. Use the stylus on the screen keypad to select YES or NO then press ENTER when finished.
7. Use the stylus on the screen to select SEND to update the 6888Xi.

## 4.7.10 Plugged diffuser diagnostic

Use a Field Communicator or the 6888Xi to configure the plugged diffuser diagnostic.

The Plugged Diffuser Diagnostic setups are only valid if the 6888Xi is configured with the Plugged Diffuser Enhanced Software Option. If the Option is not enabled in the 6888Xi, the setup selections will not appear in the menu.

A 6888Xi shipped from the factory with the Plugged Diffuser Enhanced Software Option configured will initially have the feature disabled. This same process must be performed any time an I/O Board is replaced.

### Configuring the Plugged Diffuser Diagnostic Using the 6888Xi Keypad/Display

1. Press the MENU button repeatedly until the IOB1 Probe 1 menu displays.
2. From the main menu, select DETAILED SETUP then press ENTER.
3. From the DETAILED SETUP menu, select CALIBRATION then press ENTER.
4. From the CALIBRATION menu, select DIFFUSER then press ENTER.
5. From the DIFFUSER menu, select PLUGGED DIFFUSER then press ENTER.
6. Use the UP and DOWN arrow keys to select the mode.
  - Disable – Disables this feature
  - Rate – Uses rate of change of gas value during purge to determine when purge is complete
  - Proximity – Uses comparison of pre-calibration measurement versus post-calibration measurement purge to determine when purge is complete
  - Rate&Prox – Uses both methods to determine when purge is complete (e.g. both must be true)Press ENTER to save the selection. Press the LEFT arrow key to return to the CALIBRATION menu.
7. From the CALIBRATION menu, select AUTO ADVANCE CAL then press ENTER.
8. Press the RIGHT arrow key to edit the value.
  - No – Disables the function
  - Yes – Shortens cal gas flow time or purge time if the measured gas value stabilized before the manually configured timesUse the UP and DOWN arrow keys to change the value from NO to YES or YES to NO. Press ENTER to save the new value. Press the LEFT arrow key to return to the CALIBRATION menu.
9. Press the EXIT key to return to the main menu.
10. Repeat steps 1 through 9 for PROBE 2 if configured for dual channel

### Configuring the Plugged Diffuser Diagnostic Using Field Communicator in Manual Configure Mode

1. Use the 375/475 Field Communicator to access the main HART menu.
2. From the main menu, select CONFIGURE.
3. From the CONFIGURE menu, select MANUAL SETUP.
4. From the MANUAL SETUP menu, select CALIBRATION.
5. From the CALIBRATION menu, select DIFFUSER.
6. From the DIFFUSER menu, select PLUGGED DIFFUSER.
7. Press the RIGHT arrow key to edit the value. Use the UP and DOWN arrow keys to select the mode.
  - Disable – Disables this feature
  - Rate – Uses rate of change of gas value during purge to determine when purge is complete
  - Proximity – Uses comparison of pre-calibration measurement versus post-calibration measurement purgeto determine when purge is complete
  - Rate&Prox – Uses both methods to determine when purge is complete (e.g. both must be true)
8. Use the stylus on the screen keypad to press ENTER when finished.
9. Use the stylus on the screen to select SEND to update the 6888Xi.
8. From the DIFFUSER menu, select AUTO ADVANCE CAL.
9. Press the RIGHT arrow key to edit the value. Use the UP and DOWN arrow keys to select the mode.
  - No – Disables the function
  - Yes – Shortens cal gas flow time or purge time if the measured gas value stabilized before the manually configured times
10. Use the stylus on the screen keypad to press ENTER when finished.
11. Use the stylus on the screen to select SEND to update the 6888Xi.

## 4.7.11 Low temperature set point

Use a Field Communicator or the 6888Xi to configure the low temperature setpoint.

The Low Temperature Set Point setups are only valid if the 6888Xi is configured with the Extended Temperature Enhanced Software Option. If the Option is not enabled in the 6888Xi, the setup selections will not appear in the menu.

A 6888Xi shipped from the factory with the Extended Temperature Enhanced Software Option configured will initially have the heater set to normal and the heater latch off set to off. This same process must be performed any time an I/O Board is replaced.

#### Configuring the Low Temperature Set Point Using the 6888Xi Keypad/Display

1. Press the MENU button repeatedly until the IOB1 Probe 1 menu displays.
2. From the main menu, select DETAILED SETUP then press ENTER.
3. From the DETAILED SETUP menu, select SENSOR then press ENTER.
4. From the SENSOR menu, select HEATER SP then press ENTER.
5. Press the RIGHT arrow key to edit the value.
  - Normal – Heater set point at 736 °C
  - Low – Heater set point at 550 °CUse the UP and DOWN arrow keys to select the mode. Press ENTER to save the new value. Press the LEFT arrow key to return to the SENSOR menu.
6. From the SENSOR menu, select HIGH TEMP ALM SP then press ENTER.

7. Press the RIGHT arrow key to edit the value. Use the RIGHT and LEFT arrow keys to select the digit to edit, the the UP and DOWN arrow keys to change the value of the digit. The value must be between 750 °C and 850 °C. Press ENTER to save the new value. Press the LEFT arrow key to return to the SENSOR menu.
8. From the SENSOR menu, select HEATER LATCH OFF then press ENTER.
9. Press the RIGHT arrow key to edit the value.
  - No – Heater turns off above set point, then turns back on if process falls below set point
  - Yes – Heater turns off above set point, but does not then turn back on if process falls below set pointUse the UP and DOWN arrow keys to change the value from NO to YES or YES to NO. Press ENTER to save the new value. Press the LEFT arrow key to return to the SENSOR menu.
10. Press the EXIT key to return to the main menu.
11. Repeat steps 1 through 8 for PROBE 2 if configured for dual channel.

### Configuring the Low Temperature Set Point Using Field Communicator in Manual Configure Mode

#### WARNING

Failure to remove the 6888Xi from automatic control loops prior to performing this procedure may result in a dangerous operating condition.

1. Use the 375/475 Field Communicator to access the main HART menu.
2. From the main menu, select CONFIGURE.
3. From the CONFIGURE menu, select MANUAL SETUP.
4. From the MANUAL SETUP menu, select SENSOR.
5. From the SENSOR menu, select HEATER SET POINT.
6. Press the RIGHT arrow key to edit the value. Use the UP and DOWN arrow keys to select the mode.
  - Normal – Heater set point at 736 °C
  - Low – Heater set point at 550 °C
7. Use the stylus on the screen keypad to press ENTER when finished.
8. Use the stylus on the screen to select SEND to update the 6888Xi.
9. From the SENSOR menu, select HIGH TEMP ALM SP.
10. Use the stylus on the screen keypad to enter the high temperature alarm set point value. The value must be 750 °C and 850 °C. Press ENTER when finished.
11. Use the stylus on the screen to select SEND to update the 6888Xi
12. From the SENSOR menu, select HEATER LATCH OFF.
13. Press the RIGHT arrow key to edit the value. Use the UP and DOWN arrow keys to select the mode.
  - No – Heater turns off above set point, then turns back on if process falls below set point
  - Yes – Heater turns off above set point, but does not then turn back on if process falls below set point
14. Use the stylus on the screen keypad to press ENTER when finished.

FIGURE 4-7. Calibration Methods, Simplified

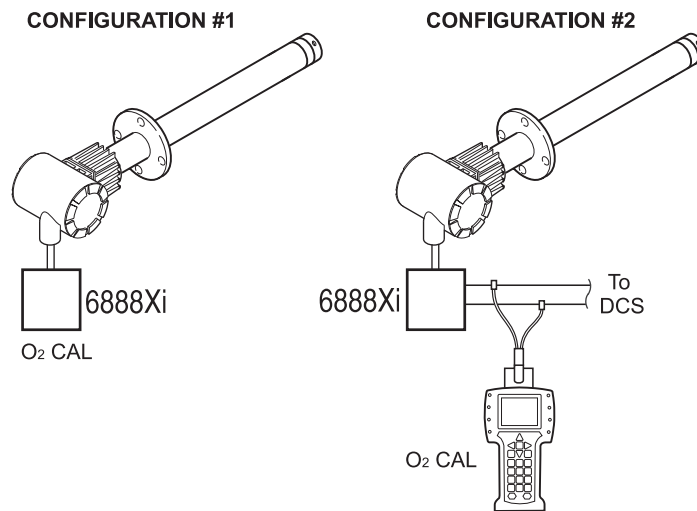

15. Use the stylus on the screen to select SEND to update the 6888Xi.

## 4.8 Calibration

### 4.8.1 General

New O<sub>2</sub> cells may operate for more than a year without requiring calibration, but older cells may require recalibration every few weeks as they near the end of their life.

A CALIBRATION RECOMMENDED alarm provides notice of when a calibration is required. This strategy ensures that the O<sub>2</sub> reading is always accurate and eliminates many unnecessary calibrations based on calendar days or weeks since previous calibration.

The O<sub>2</sub> Probe(s) can be calibrated manually through the handheld 375/475 Field Communicator or the 6888Xi. Fully automatic calibration can be performed automatically using the 6888Xi and the SPS 4001B Single Probe Autocalibration Sequencer.

### 4.8.2 Calibration procedure

This section covers manual calibration. For automatic calibration details see the Manual for the SPS 4001B Single Probe Autocalibration Sequencer.

Calibration can be performed using two basic calibration methods. The methods available to you for use depend on the configuration of your system. The paragraphs that follow describe how to perform a calibration for the configurations shown in Figure 3-7.

Setup of the calibration parameters should be performed before the first O<sub>2</sub> calibration. Thereafter, perform calibration setup only as needed to change the calibration parameters or to reset the parameters following the replacement of primary system components.

When performing a calibration, certain settings will cause specific actions to occur. If calibration acknowledge is set to yes, each calibration will generate an alarm condition that requires the operator to decide whether or not to accept the new calibration. The 6888XI will continue to function after the calibration completes, but the new slope and constant will not be implemented until accepted. If the 6888XI has the diffuser warning function activated, a diffuser warning alarm may occur after a calibration. If an alarm occurs, it will need to be acknowledged and the associated parameters need to be reviewed to determine if there is any significant fouling of the diffuser.

O<sub>2</sub> Calibration with 6888Xi

 **WARNING**

**Failure to remove the 6888Xi from automatic control loops prior to performing this procedure may result in a dangerous operating condition.**

For systems with configuration 1, shown in Figure 3-5, use the following procedure to perform a calibration using the 6888Xi. If necessary, use the 6888Xi menu tree in Figure 3-2 for reference. Multiprobe Test Gas Sequencer.

1. Press the MENU button repeatedly until the IOB1 Probe 1 menu displays.
2. From the main menu, select CALIBRATION then press ENTER.
3. From the CALIBRATION menu, select O2 CALIBRATION then press ENTER.
4. In the first screen, a “Ctrl Loop to Manual” warning occurs. Remove the 6888XI from any automatic controls loops to avoid a potentially dangerous operating condition. Press ENTER when ready to start calibration.
5. Follow the prompts on the 6888XI display to perform the calibration.
6. The STOP GAS 2 step screen just prior to the purge step will display the calibration result. In the event the calibration cycle fails, the reason will be displayed here as well. The calibration results are described as follows:

Success – Calibration completed successfully.

Failed Constant – The calculated calibration constant is outside the range of  $\pm 20.00$ .

Failed Slope – The calculated calibration slope is outside the range of 34.5 to 57.5.

Failed Temperature – With the extended temperature function enabled and the operating above the heater set point, the process temperature varied by more than  $\pm 5^{\circ}\text{C}$  during the calibration cycle.

Gas 1 Tolerance Error – The measured value for gas 1 varied more than  $\pm 10\%$  from the programmed value. Possible causes are incorrect gas value programmed in the 6888XI, incorrect gas value in bottle, or gas bottle is empty. This error can occur only if the Tolerance Check feature is active.

Gas 2 Tolerance Error – The measured value for gas 2 varied more than  $\pm 10\%$  from the programmed value. Possible causes are incorrect gas value programmed in the 6888XI, incorrect gas value in bottle, or gas bottle is empty. This error can occur only if the Tolerance Check feature is active.

AutoCal No Resp – No communication or loss of communication to the SPS4001B.

AutoCal OutofSync – Loss of communication synchronization to the SPS4001B.

AutoCal Abort – The SPS4001B aborted the calibration cycle due to a low gas bottle indication.

WarmUp Abort – Attempted to perform a calibration during warmup.

Alarm Abort – Another alarm occurred and caused the calibration cycle to abort.



- In the event of a calibration failure, perform the following steps. Otherwise, proceed to the next step.
- a. From the final calibration screen, press EXIT twice to return to the main display screen. The screen should indicate an alarm condition.
  - b. Press DIAG to view the alarms. A CAL FAILED alarm should be shown.
  - c. Press EXIT to return to the DIAGNOSTIC menu.
  - d. From the DIAGNOSTIC menu, select ACKNOWLEDGE ALARMS then press ENTER.
  - e. From the ACKNOWLEDGE ALARMS menu, select ACK CAL FAILED then press ENTER.
  - f. When complete, press EXIT twice to return to the main display screen.
  - g. Press DIAG to verify the CAL FAILED alarm no longer is shown.
7. If the Calibration Acknowledge parameter is ON, perform the following steps. Otherwise, proceed to the next step.
- a. From the final calibration screen, press EXIT twice to return to the main display screen. The screen should indicate an alarm condition.
  - b. Press DIAG to view the alarms. A CAL CHANGED alarm should be shown.
  - c. Press EXIT to return to the DIAGNOSTIC menu.
  - d. From the DIAGNOSTIC menu, select ACKNOWLEDGE ALARMS then press ENTER.
  - e. From the ACKNOWLEDGE ALARMS menu, select ACK CALIBRATION then press ENTER.
  - f. In this screen, a “Ctrl Loop to Manual” warning occurs. Remove the 6888XI from any automatic controls loops to avoid a potentially dangerous operating condition. Press ENTER when ready to continue.
  - g. The next screen shows the CURRENT CAL and NEW CAL slope and constant values. Press ENTER to continue.
  - h. Use the UP and DOWN arrow keys to change the value from NO to YES or YES to NO. Press ENTER to continue. Press EXIT twice to return to the main display screen.
  - i. Press DIAG to verify the CAL CHANGED alarm no longer is shown.
8. If the Diffuser Warning Function is active, perform the following steps. Otherwise, proceed to the next step.
- a. From the final calibration screen, press EXIT twice to return to the main display screen. The screen should indicate an alarm condition.
  - b. Press DIAG to view the alarms. A DIFFUSER WARNING alarm should be shown.
  - c. Press EXIT to return to the DIAGNOSTIC menu.
  - d. From the DIAGNOSTIC menu, select ACKNOWLEDGE ALARMS then press ENTER.
  - e. From the ACKNOWLEDGE ALARMS menu, select ACK DIFF WARN then press ENTER.
  - f. When complete, press EXIT twice to return to the main display screen.
  - g. Press DIAG to verify the DIFFUSER WARNING alarm no longer is shown.
9. Repeat steps 1 through 5 for PROBE 2 if configured for dual channel.

#### **Aborting O<sub>2</sub> Calibration with 6888Xi**

1. From the calibration prompt screen, press the LEFT arrow key to return to the CALIBRATION menu.
2. From the CALIBRATION menu, select ABORT CALIBRATION then press ENTER.
3. At the prompt, select ENTER to verify the abort command.
4. The cycle will halt in approximately 10 seconds. When prompted, press ENTER to continue.
5. The abort will continue with a purge delay according to the time programmed in the calibration setup. When the purge time expires and the step indicates IDLE, the abort process is completed. Press EXIT, then OK to return to the CALIBRATION menu.

#### **O<sub>2</sub> Calibration with 6888Xi and Field Communicator**

1. Use the 375/475 Field Communicator to access the main HART menu.
2. From the main menu, select CONFIGURE.

3. From the CONFIGURE menu, select CALIBRATION.
4. From the CALIBRATION menu, again select CALIBRATION.
5. From the CALIBRATION menu, select O2 CALIBRATION.
6. In the first screen, a “Loop should be removed from automatic control” warning occurs. Remove the 6888Xi from any automatic controls loops to avoid a potentially dangerous operating condition. Press OK when ready.
7. At the next screen when step shows APPLY GAS 1, press OK to return to the SELECT ACTION menu.
8. At the SELECT ACTION menu, select STEP CALIBRATION then ENTER to begin the calibration with Flow Gas 1.
9. When Flow Gas 1 and Read Gas 1 are complete and the step shows APPLY GAS 2, press OK to return to the SELECT ACTION menu.
10. At the SELECT ACTION menu, select STEP CALIBRATION then ENTER to continue the calibration with Flow Gas 2.
11. When Flow Gas 2 and Read Gas 2 are complete and the step shows STOP GAS, press OK to return to the SELECT ACTION menu.
12. At the SELECT ACTION menu, select STEP CALIBRATION then ENTER to continue the calibration with Purge.
13. When the step shows IDLE, press OK to return to the SELECT ACTION menu.
14. At the SELECT ACTION menu, select EXIT CALIBRATION, press ENTER, then OK to return to the CALIBRATION menu.
15. At the CALIBRATION menu, select RESULT.
16. At the RESULT menu, the results of the calibration will be displayed. In the event the calibration cycle fails, the reason will be displayed here as well. The calibration results are described as follows:
  - Success – Calibration completed successfully.
  - Failed Constant – The calculated calibration constant is outside the range of  $\pm 20.00$ .
  - Failed Slope – The calculated calibration slope is outside the range of 34.5 to 57.5.
  - Failed Temperature – With the extended temperature function enabled and the operating above the heater set point, the process temperature varied by more than  $\pm 5^{\circ}\text{C}$  during the calibration cycle.
  - Gas 1 Tolerance Error – The measured value for gas 1 varied more than  $\pm 10\%$  from the programmed value. Possible causes are incorrect gas value programmed in the 6888XI, incorrect gas value in bottle, or gas bottle is empty. This error can occur only if the Tolerance Check feature is active.
  - Gas 2 Tolerance Error – The measured value for gas 2 varied more than  $\pm 10\%$  from the programmed value. Possible causes are incorrect gas value programmed in the 6888XI, incorrect gas value in bottle, or gas bottle is empty. This error can occur only if the Tolerance Check feature is active.
  - AutoCal No Resp – No communication or loss of communication to the SPS4001B.
  - AutoCal OutofSync – Loss of communication synchronization to the SPS4001B.
  - AutoCal Abort – The SPS4001B aborted the calibration cycle due to a low gas bottle indication.
  - WarmUp Abort – Attempted to perform a calibration during warmup.
  - Alarm Abort – Another alarm occurred and caused the calibration cycle to abort. In the event of a calibration failure, perform the following steps. Otherwise, proceed to the next step.
    - a. From the RESULT menu, press HOME to return to the main menu.
    - b. From the main menu, select SERVICE TOOLS.

- c. From the OVERVIEW menu, select ALERTS.
  - d. From the ALERTS menu, select ACTIVE ALERTS.
  - e. The ACTIVE ALERTS menu should contain an A: CALIBRATION FAILED alarm. Press the left arrow key to return to the ALERTS menu.
  - f. From the ALERTS menu, select DEVICE STATUS.
  - g. From the DEVICE STATUS menu, select ACKNOWLEDGE.
  - h. From the ACKNOWLEDGE menu, select ACK CALIBRATION FAILED. When the process is complete, the screen will return to the ACKNOWLEDGE menu.
17. If the Calibration Acknowledge parameter is ON, perform the following steps. Otherwise, proceed to the next step.
- a. Press HOME to return to the main menu.
  - b. From the main menu, select SERVICE TOOLS.
  - c. From the OVERVIEW menu, select ALERTS.
  - d. From the ALERTS menu, select ACTIVE ALERTS.
  - e. The ACTIVE ALERTS menu should contain an M: CALIBRATION CHANGED alarm. Press the left arrow key to return to the ALERTS menu.
  - f. From the ALERTS menu, select DEVICE STATUS.
  - g. From the DEVICE STATUS menu, select ACKNOWLEDGE.
  - h. From the ACKNOWLEDGE menu, select ACK CALIBRATION.
  - i. The next screen shows the CURRENT CAL and NEW CAL slope and constant values. Press OK to continue.
  - j. Use the UP and DOWN arrow keys to change the value from NO to YES or YES to NO. Press ENTER to continue. If YES is selected, the Field Communicator will respond CALIBRATION CONSTANTS ACCEPTED. ALERT CLEARED. Press OK to return to the ACKNOWLEDGE menu.
18. If the Diffuser Warning Function is active, perform the following steps.
- a. Press HOME to return to the main menu.
  - b. From the main menu, select SERVICE TOOLS.
  - c. From the OVERVIEW menu, select ALERTS.
  - d. From the ALERTS menu, select ACTIVE ALERTS.
  - e. The ACTIVE ALERTS menu should contain an A: DIFFUSER WARNING alarm. Press the left arrow key to return to the ALERTS menu.
  - f. From the ALERTS menu, select DEVICE STATUS.
  - g. From the DEVICE STATUS menu, select ACKNOWLEDGE.
  - h. From the ACKNOWLEDGE menu, select ACK DIFFUSER WARNING. When the process is complete, the screen will return to the ACKNOWLEDGE menu.

#### **Aborting O<sub>2</sub> Calibration with 6888Xi and Field Communicator**

1. From the calibration prompt screen, press the OK button to return to the SELECT ACTION menu.
2. From the SELECT ACTION menu, select ABORT CALIBRATION then press ENTER.
3. The cycle will halt in approximately 10 seconds. When the step shows STOP GAS, press OK to return to the SELECT ACTION menu.
4. From the CALIBRATION menu, select STEP CALIBRATION then ENTER.
5. The abort will continue with a purge delay according to the time programmed in the calibration setup. When the step shows IDLE, press OK to return to the SELECT ACTION menu.
6. From the SELECT ACTION menu, select EXIT CALIBRATION then ENTER, the OK to return to

return to the CALIBRATION menu.

 **WARNING**

**Failure to remove the 6888Xi from automatic control loops prior to performing this procedure may result in a dangerous operating condition.**

### 4.8.3 Calibration log

The 6888Xi stores the current and 10 previous calibrations. The stored data includes the slope, constant, cell impedance and time (in days) since that calibration. The log can be accessed as follows:

Using the 6888Xi Keypad & Display: IOB 1 Probe 1(or 2)\Calibration\Cal Constants\  
Cal Logs

Using the Field Communicator: Configure\Calibration\Calibration  
Constants\Calibration Logs

When first entering the log, the screen will display calibration 1. This is the most recent previous calibration, not the current calibration. Calibration 0 displays the current calibration. Use the keypad or communicator keys to navigate through the logs. The factory default for log entries is a slope of 50.00 mV/Dec and constant of 0.00 mV. Any log entries with these values means there have not been at least 10 calibrations performed to fill the entire log.

 **WARNING**

**Failure to remove the 6888Xi from automatic control loops prior to performing this procedure may result in a dangerous operating condition.**

### 4.8.4 Reset calibration

The 6888Xi has the ability to reset the current calibration and replace it with the previous. A calibration may be reset in cases where the calibration was acknowledged in error or the calibration was known to contain invalid values. Resetting a calibration will transfer the slope and constant from calibration 1 in the log into the calibration 0 position. The cell impedance and days since calibration remain unchanged.

Reset the calibration as follows:

Using the 6888Xi Keypad & Display: IOB 1 Probe 1(or 2)\Calibration\Cal Constants\  
Current Cal\Reset Cal

Using the Field Communicator: Configure\Calibration\Calibration Constants\  
Reset Calibration Constants

FIGURE 4-8. D/A Trim Methods, Simplified

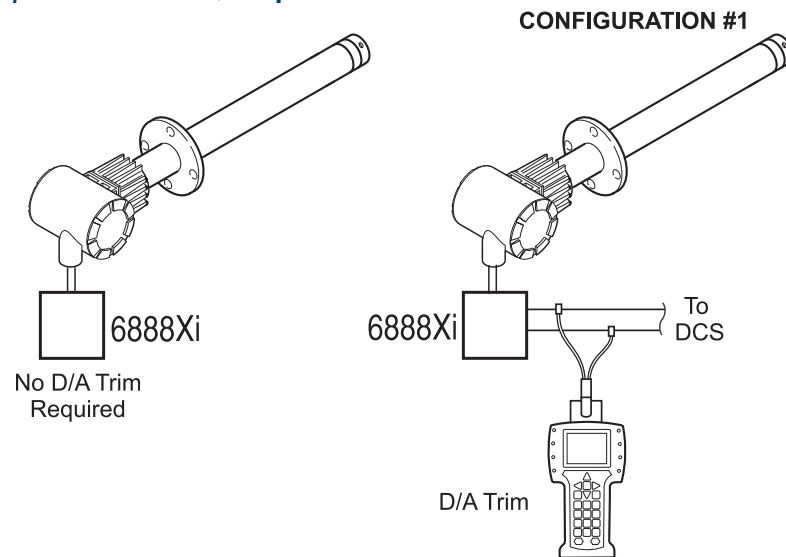

Follow the instructions on the screen to complete the reset function.

**WARNING**

Failure to remove the 6888Xi from automatic control loops prior to performing this procedure may result in a dangerous operating condition.

## 4.9 D/A trim

The D/A trim procedure is used to calibrate the 4-20 mA output signal to a precision mA measurement device. Only the signal to the DCS needs to be trimmed.

### D/A Trim with 6888Xi

1. Press the MENU button repeatedly until the IOB1 Probe 1 menu displays.
2. From the main menu, select DIAGNOSTICS then press ENTER.
3. From the DIAGNOSTICS menu, select MAINTENANCE then press ENTER.
4. From the MAINTENANCE menu, select ANALOG OUTPUT then press ENTER.
5. From the ANALOG OUTPUT menu, select TRIM mA OUTPUT then press ENTER.
6. In the first screen, a “Remove Loop from Auto” warning occurs. Remove the 6888Xi from any automatic controls loops to avoid a potentially dangerous operating condition. Press ENTER when ready to start.
7. Follow the prompts on the 6888Xi display to perform the trim.
8. Use the RIGHT and LEFT arrow keys to select the digit to edit, then the UP and DOWN arrow keys to change the value of the digit. Press ENTER to save the new value. Press ENTER to accept the change.
9. When complete, press EXIT to return to the ANALOG OUTPUT menu.
10. Repeat steps 1 through 9 for PROBE 2 if configured for dual channel.

### D/A Trim with 6888Xi and Field Communicator

1. Use the 375/475 Field Communicator to access the main HART menu.
2. From the main menu, select SERVICE TOOLS.

3. From the SERVICE TOOLS menu, select MAINTENANCE.
4. From the MAINTENANCE menu, select ANALOG OUTPUT.
5. From the ANALOG OUTPUT menu, select TRIM mA OUTPUT.
6. In the first screen, a “Loop should be removed from automatic control” warning occurs. Remove the 6888Xi from any automatic controls loops to avoid a potentially dangerous operating condition. Press OK when ready.
7. Follow the prompts on the 6888Xi display to perform the trim.
8. Use the stylus on the screen to enter the new measured analog output value then press ENTER to accept.
9. When trim is complete, press OK to return to the ANALOG OUTPUT menu.

# Section 5: Troubleshooting

## 5.1 Overview

When the Zirconium Oxide sensing cell is heated to its setpoint [736 °C (1357 °F)], the cell will generate a voltage that represents the difference between the process O<sub>2</sub>% and the reference O<sub>2</sub>% inside the probe (20.95% O<sub>2</sub> instrument or ambient air).

When flowing calibration gases, the raw cell millivolt value should represent the levels on the chart in Figure 4-1. Note that the raw cell millivolt value increases logarithmically as the O<sub>2</sub> concentration decreases.

**FIGURE 5-1. O<sub>2</sub> Sensor mV Reading vs %O<sub>2</sub> at 736°C (1357°F) (Reference Air, 20.95% O<sub>2</sub>)**

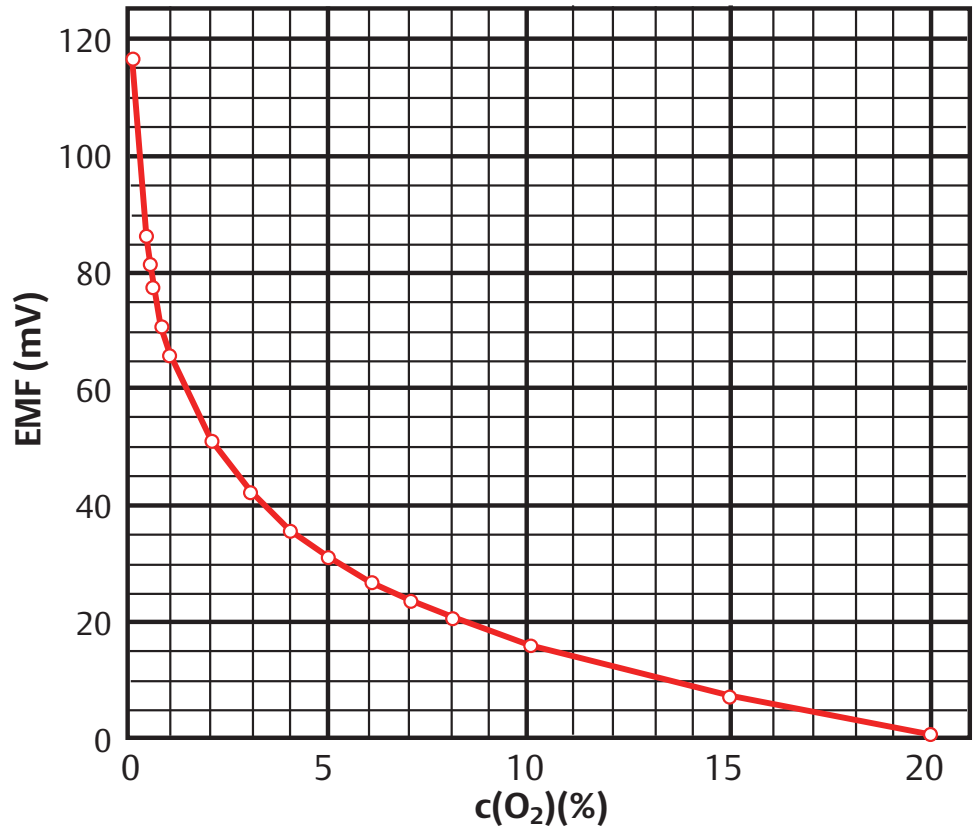

O <sub>2</sub> %	100	20	15	10	9	8	7	6	5	4
EMF (mV)	-34	1.0	7.25	16.1	18.4	21.1	23.8	27.2	31.2	36.0
O <sub>2</sub> %	3	2	1	0.8	0.6	0.5	0.4	0.2	0.1	0.01
EMF (mV)	42.3	51.1	66.1	71.0	77.5	81.5	86.3	101.4	116.6	166.8

## 5.2 General

### WARNING

**Install all protective equipment covers and safety ground leads after troubleshooting. Failure to install covers and ground leads could result in serious injury or death.**

Consider the following equipment conditions, features, and requirements when troubleshooting a problem.

### 5.2.1 Grounding

It is essential that adequate grounding precautions are taken when installing the system. Thoroughly check both the probe and electronics to ensure the grounding quality has not degraded during fault finding. The system provides facilities for 100% effective grounding and the total elimination of ground loops.

### 5.2.2 Electrical noise

The 6888Xi has been designed to operate in the type of environment normally found in a boiler room or control room. Noise suppression circuits are employed on all field terminations and main inputs. When fault finding, evaluate the electrical noise being generated in the immediate circuitry of a faulty system. Ensure all cable shields are connected to earth.

### 5.2.3 Electrostatic discharge

Electrostatic discharge can damage the ICs used in the electronics. Before removing or handling the circuit boards, ensure you are at ground potential.

## 5.3 Alarm indications

The first indication of a problem at the O<sub>2</sub> measuring system usually comes from the operators running the process. Critical alarms that render the O<sub>2</sub> measurement unusable will force the 4-20 mA analog output signal representing O<sub>2</sub> to go to a default condition, as follows:

**Table 5-1 - Alarm Indications**

4-20 mA Signal Alarm Level	Transmitter Condition
0 mA	Transmitter unpowered, or completely failed
3.5 mA	Critical Alarm - transmitter reading unusable (factory default)
3.8 mA	Reading Under Range (Example - user sets range to 2-10%. Current reading is 1.9%)
4 to 20 mA	Normal Operation
20.5 mA	Reading Over Range (Example - range is 0-10%. Current reading is 12%)
>21 mA	Critical Alarm - transmitter reading is unusable (user can choose this alarm level instead of the factory default level of 3.5 to 3.6 mA)



**NOTE**

For correct operation, ensure the Distributed Control System is configured to interpret these signal levels correctly.

Once an alarm condition is identified, the 6888Xi offers a number of diagnostics to interpret the specific alarm.

Alarm indications are available via the 6888Xi or the 475 Field Communicator and Rosemount Analytical's Asset Management software. When the error is corrected and/or power is cycled, the diagnostic alarms will clear or the next error on the priority list will appear.

## 5.4 Identifying and correcting fault indications

There are two types of alarms; recoverable and non recoverable. If an existing alarm is recoverable, the alarm-active indication will disappear when the alarm condition no longer exists. If an alarm is not recoverable, the alarm indication will continue to be displayed after the cause of the alarm condition is corrected. AC power to the 6888Xi must be cycled to clear a non-recoverable alarm.

Alarm messages are displayed on the 6888Xi display window when the alarm status display is accessed via the 6888Xi menu. A listing of the alarm/fault messages and the related fault status descriptions are shown in Table 4-2.

Fault conditions that give no fault indication and that allow the probe to pass calibration are listed and discussed after Table 4-2.

**Table 5-2 - Diagnostic/Unit Alarm Fault Definitions (1 of 2)**

Message	Status	Alert	Self Clearing	4-20 mA Critical Alarm
NV Memory Fail	A checksum error was detected in the nonvolatile memory configuration data when the unit was turned on. Default values have been loaded. Check to see that your configurations have not been changed. Cycle the power to clear alarm.	Failed	N	Y
Board Temp High	The electronics board temperature reading is above the threshold. The board may not function correctly. The predefined temperature threshold is 86 °C for IO board or 126 °C for Transmitter board.	Failed	N	Y
Heater Ramp Rate	Heater ramp rate is greater than the defined warm-up ramp rate. Heater may be out of control. Alarm condition: If the heater ramp rate stay above 3.5 °C/sec for 30 seconds continuously.	Failed	N	Y
O2 Sensor Open	The cell impedance voltage is reading less than -1.0 VDC indicating the O2 sensor wires may be disconnected or the O2 sensor junction may be open. Check wiring.	Maint	Y	Y
O2 T/C Open	The O2 sensor heater thermocouple voltage is reading more than 0.065 volt indicating the thermocouple wires may be disconnected or the thermocouple junction may be open. Check wiring.	Maint	Y	Y
O2 Temp Low	The sensor heater temperature is below the low temperature threshold. If Extended Temperature feature is not enabled, the predefined low temperature threshold is the 726 °C. If Extended Temperature feature is enabled, the predefined low temperature threshold is the 726 °C if the "Heater SP" is set to "Normal" or 540 °C for it is set to "Low".	Maint	Y	Y

**Table 5-2 - Diagnostic/Unit Alarm Fault Definitions (2 of 2)**

Message	Status	Alert	Self Clearing	4-20 mA Critical Alarm
O2 Temp High	The sensor heater temperature is above the high temperature threshold. If Extended Temperature feature is not enabled, the predefined high temperature threshold is 750 °C. If Extended Temperature feature is enabled, the high temperature threshold is the defined by the “High Temp Alm SP” parameter.	Maint	Y	Y N
O2 T/C Shorted	This diagnostic is only intended to detect a copper short of the thermocouple connections at the electronics connector. The Cell Heater T/C voltage is reading close to zero indicating the thermocouple wires may be shorted.	Maint	Y	Y
O2 T/C Reversed	The O2 sensor heater temperature thermocouple voltage is reading a negative voltage and is decreasing indicating the thermocouple wire connections may be reversed. Check wiring.	Maint	N	Y
Heater Failure	The O2 sensor heater temperature is not responding to the controller and can't reach final temperature set by the device, indicating the O2 heater may have failed.	Maint	Y	Y
Burner Flameout	The Flame Status Relay Input is set to the OFF state indicating it is not safe to operate the sensor heater and the heater should be turned off.	Maint	Y	Y
Xmtr Disconnect	Communication failures detected between transmitter and the IO board indicating the transmitter has been disconnected from the IO board. Check the connecting cable.	Maint	Y	Y
Cal Recommended	Probe calibration is recommended. The cell impedance has shifted enough (above 100 ohms and has shifted 50 ohms) since the last calibration that the accuracy may be compromised	Maint	Y	N
Cal Failed	A calibration error occurred during the last calibration. Check the Cal Result for more details. Acknowledge Calibration Failed or recalibrate to clear alarm.	Maint	Y	N
Cell Imp High	The cell impedance reading is above threshold (2000 Ohms) indicating the cell may be beyond its useful life.	Maint	Y	N
Probe Mismatch	The probe type does not match indicating wrong Transmitter board or probe is connected.	Maint	Y	Y
Xi Disconnect	It indicates using Transmitter's AO when connected to Xi and Xi is disconnected.	Maint	Y	Y
Cal Changed	Calibration constants have been changed. Acknowledge Calibration to update constants and clear alarm.	Adv	Y	N
Heater Volt Low	The heater voltage for the O2 heater is below 30 volt. Check Heater Power.	Adv	Y	N
Probe Changed	The probe or Transmitter board has been changed. Acknowledge Probe Changed to synchronize calibration constants and clear alarm.	Adv	Y	N
Low O2	The O2 reading is below the threshold. The threshold is defined by the “Low O2 Alm SP”.	Adv	Y	N
Diffuser Warning	There can be multiple causes for the alert. The diffuser or cal line may be plugged, the cell may be pressurized, the cal gas bottle may be empty, or cal gas may not be turned on. Acknowledge Diffuser Warning to clear alarm then check Diffuser Warn for more details.	Adv	Y	N

## 5.5 Calibration passes, but still reads incorrectly

There are a few fault conditions where no alarm indication is present and the probe passes calibration, but the O<sub>2</sub> reading may still be incorrect:

1. An incorrect flow rate of calibration gases can cause a shifted calibration. If the flow rate of calibration gases is too low, process gases can mix in with the calibration gases causing a mix-

ture at the cell that is different than what is noted on the calibration gas bottles. Always set the calibration flow rate when a new diffuser is installed, and never readjust this flow rate until another new diffuser is installed. For applications with heavy particulate loading, see "Probe Passes Calibration, O<sub>2</sub> Still Reads Low". Always use a two stage pressure regulator for calibration gas.

2. No or improper reference air supplied.

## 5.5.1 Probe passes calibration, O<sub>2</sub> still reads high

**External Reference Air Leak** - There may be a leak that is permitting ambient air to mix with the process gases. Since many combustion processes are slightly negative in pressure, ambient air can be drawn into the cell area, biasing the O<sub>2</sub> reading upward.

1. Make sure that the calibration gas line is capped tightly between calibrations.
2. If autocal is used, make sure the check valve is seating properly.
3. If an abrasive shield is used, a small leak at the probe flange gasket can migrate down the annular space between the probe OD and shield ID to the sensing cell causing a false high O<sub>2</sub> reading.

**FIGURE 5-2. Probe Leakage Paths**

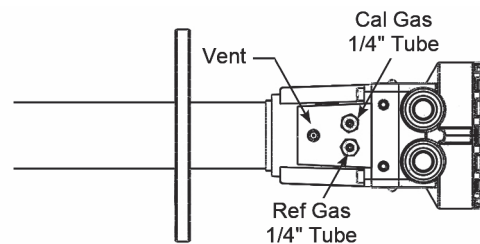

**Internal Reference Air Leak** - See Figure 4-2. There may be a leak inside the O<sub>2</sub> Probe itself, permitting the reference air (20.95% O<sub>2</sub>) to mix with the process gases at the cell. To confirm this leak condition, pressurize the inside (reference side) of the probe by plugging the reference air exhaust port with your finger for 1 minute. (The conduit ports where the signal and power wires pass may also need to be sealed.) The O<sub>2</sub> reading should decrease slightly. If the O<sub>2</sub> reading increases during this test there is a leak inside the probe.

1. Acid condensation inside the probe can degrade the hose that carries the cal gas to the cell. Inspect this hose. Dislodging or improper installation of the cal gas or reference air hose can cause a leakage path.

### NOTE

**Always install a new corrugated washer whenever the sensing cell is removed from the probe.**

2. The sensing cell is fastened to the end of the probe tube and uses a corrugated washer to separate the process gases from the ambient reference air. The corrugated washer may be damaged by corrosion. Discard used washer.

**Bad Reference Side Cell Electrode** - A bad reference side cell electrode can cause an elevated O<sub>2</sub> reading. This fault is usually indicated by a frequent "Calibration Recommended" alarm and increasing cell impedance readings. A high cell impedance can be calibrated out, but if the impedance continues to increase rapidly, the sensing cell must be replaced.

## 5.5.2 Probe passes calibration, O<sub>2</sub> still reads low

The diffusion element at the end of the probe is a passive filter. It plugs very slowly, since there is no active flow being drawn across it. In applications that have a heavy particulate loading (coal or wood fired boilers, cement and lime kilns, catalyst regeneration, recovery boilers, etc.), this diffusion element will eventually plug.

### NOTE

**It is important not to pressurize the sensing cell during calibrations by flowing excessive cal gas against a plugged diffuser. Always use a two-stage regulator for setting calibration gas pressure. Calibration flow rates should be set only when a new diffuser is installed. As the diffuser plugs, do not adjust the flow rates upward.**

## 5.5.3 How do I detect a plugged diffuser?

The O<sub>2</sub> cell's speed of response will degrade. The O<sub>2</sub> trend in the control room will become smoother.

When calibrating, the calibration gas flow rate will be noted to be lower. Never readjust this flow upwards to correct for a plugged diffuser. Adjust this flow only when a new diffuser is installed.

Always note the time it takes for the cell to recover to the normal process value after the cal gas is removed. As the diffuser plugs, this recovery time will get longer and longer. Use the Calibration Record provided to record and track Calibration Response times.

The 6888Xi Advanced Electronics is available with enhanced software feature to automatically characterize the rate of diffuser plugging during a calibration cycle.

## 5.5.4 Can I calibrate a badly plugged diffuser?

It may not be possible to immediately replace a plugged diffuser while the process is on line.

One can calibrate the probe without pressurizing the cell by adjusting the calibration gas flow rate downward before calibration. For instance, say the process is at 3%, and the first calibration gas is 8%. Adjust the flow of cal gas downward until the reading begins to migrate from 8% to lower values, indicating that process gases are now mixing in with the calibration gases.

Adjust the flow rate back up until this mixing is just eliminated. Calibrate at this flow rate. Replace the diffuser at the first opportunity.

### WARNING

**Install all protective equipment covers and safety ground leads after troubleshooting. Failure to install covers and ground leads could result in serious injury or death.**





## Section 6: Maintenance and service

### 6.1 Overview

 **WARNING**

**Install all protective equipment covers and safety ground leads after equipment repair or service. Failure to install covers and ground leads could result in serious injury or death.**

This section identifies the calibration methods available and provides the procedures to maintain and service the 6888Xi.

### 6.2 Maintenance intervals

The maintenance interval required is quite variable, depending on the type of service the analyzer is placed into. The zirconium oxide sensing cell is non-depleting, and has no specific shelf life or a defined life in flue gas operation. The cell of a probe that is mounted inside a boiler that is burning natural gas may shift very little over several years. Acidic compounds are the main aggressors to the sensing cell, typically SO<sub>2</sub> resulting from sulfur contained in coal and heavy oil fuels, and also HCl from the combustion of plastics in municipal incinerators and in industrial thermal oxidizers. Sensing cells may experience significant degradation and signal shift in this type of service, particularly if the operating levels of O<sub>2</sub> are very low (below 1% O<sub>2</sub>).

A calibration check is generally recommended on a quarterly basis (every 3 months) by flowing bottled gas to the probe. (Make sure that the operations personnel are notified when doing this, and also make sure that the O<sub>2</sub> control loop is placed in manual mode). If the probe readings vary significantly from the bottle values, then a formal calibration should be conducted as noted in Section 3: Configuration, Startup and Operation.

The 6888Xi offers a "calibration recommended" diagnostic that will indicate when the probe needs to be calibrated.

Combustion processes that have a high level of ash or other particulate content will cause the diffusion element on the end of the probe to plug off. A badly plugged diffuser will cause a slower speed of response to changing O<sub>2</sub> levels in the process. This can usually be seen on the recorded trends in the control room.

When performing a calibration check or actual calibration, the calibration flow meter may read lower if the diffuser is badly plugged. (Never increase the flow rate back up, however, as this can cause a shifted calibration. Adjust the calibration flow rate only when a new diffuser is installed). Always record the response time back to the process after the calibration gases are removed, as noted on the calibration record at the end of this section. Diffuser pluggage can be tracked through this record.

A visual inspection of the probe should be conducted during plant outages, paying particular attention to condensed components. Condensation can be reduced or eliminated by insulating the probe installation, including the probe mount, flange, and blue housing.

## 6.3 Calibration

The 6888Xi can calibrate an O<sub>2</sub> Probe manually through the front panel display or via a handheld 375/475 Field Communicator, or automatically through the SPS 4001B Single Probe Autocalibration Sequencer.

### 6.3.1 Automatic calibration

The 6888Xi can be used with the SPS 4001B in order to perform an auto / semi-auto calibration. Refer to the SPS 4001B Manual for further details on how to configure and perform an automatic calibration.

### 6.3.2 Manual calibration

Refer to the "Calibration - General" in Section 3: Configuration, Startup and Operation to perform a manual calibration.

FIGURE 6-1. 6888Xi Components

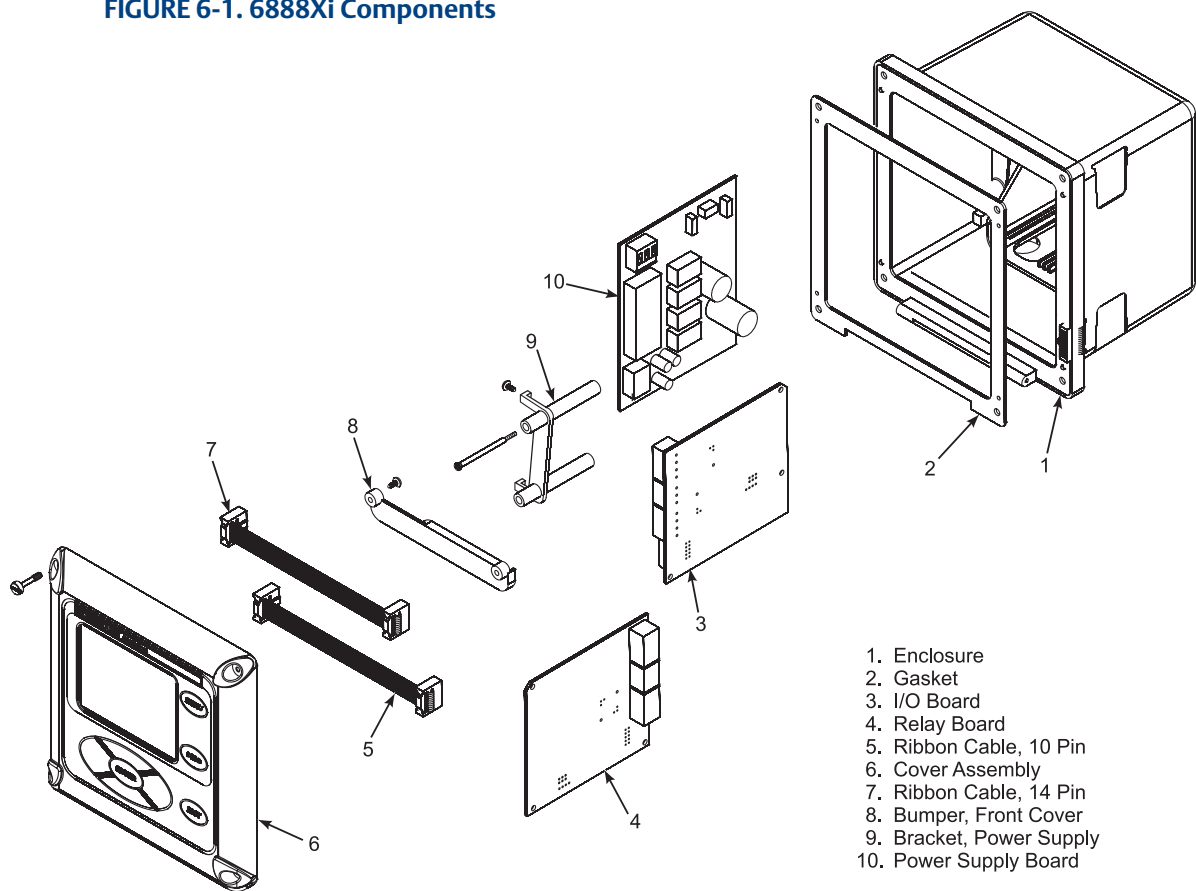



## 6.4 Replacement parts

Refer to Section 6: Replacement Parts for individual replacement parts and part replacement kits. Part replacement kits are available for each of the components discussed in this section.

## 6.5 Rosemount 6888Xi component replacement

Each of the following procedures detail how to replace a specific component of the 6888Xi. Most of these procedures include component setup instructions that must be performed before returning the related O2 Probe to service. Refer to Figure 5-1 and Figure 5-2 for illustrations of the 6888Xi components.

### 6.5.1 Input/output (I/O) board replacement

**⚠ WARNING**

Disconnect and lock out power before working on any electrical components.

**⚠ WARNING**

The I/O Board is shipped from the factory without any of the enhanced software features activated. These features must be activated once the new board has been installed and before the Remote Interface is put into service.

**FIGURE 6-2. 6888Xi Components**

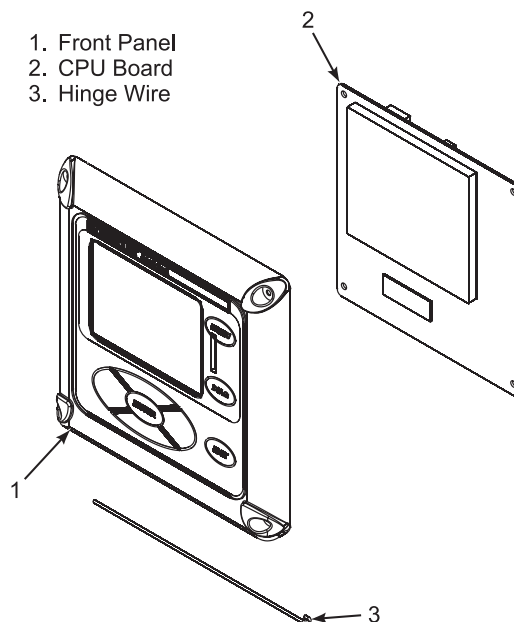
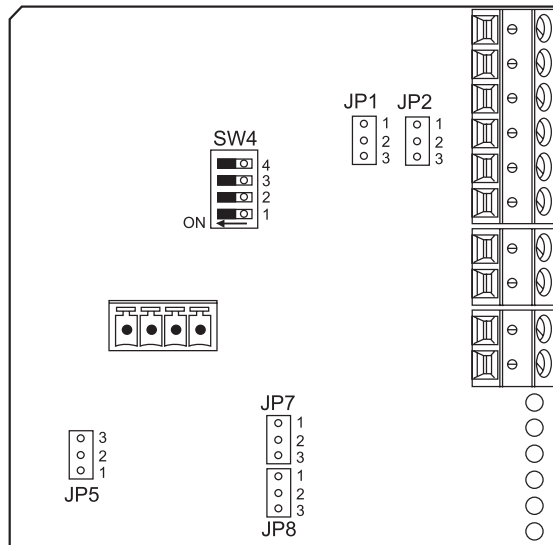

FIGURE 6-3. I/O Board Jumper & Switch Settings



Configuration	Desired Selection	Jumper	Jumper Setting
Flame Safety Function or Extra Alarm Output	Flame Safety Function (Factory configured when ordered with Flame Safety Interlock Feature)	JP1 & JP2 (both must be set the same)	Pins 1 & 2
	Extra Alarm Output		Pins 2 & 3
Loop Power for 4-20 mA/HART Signal from 6888Xi to Probe	Powered from 6888Xi (most common method)	JP5	Pins 1 & 2
	Powered from External DC Supply		Pins 2 & 3
Loop Power for 4-20 mA/HART Signal from 6888Xi to DCS	Powered from 6888Xi	JP7 & JP8 (both must be set the same)	Pins 1 & 2
	Powered from DCS		Pins 2 & 3

Sw4 Switch Settings: (Default = OFF)  
 1: Reserved; must remain OFF.  
 2: Not used.  
 3: Not used.  
 4: Flame safety function enable.

**WARNING**

If the existing I/O Board has been operated with enhanced software features, these features must be activated in the new board before the 6888Xi Electronics is put back into service. Failure to do so will cause a false analog output signal to the DCS.

Use the procedure that follows to replace and set up the I/O board in the 6888Xi.

**Replacing an Existing I/O Board**

- Loosen the four screws securing the 6888Xi cover. The screws are captive and do not need to be completely removed.
- Swing the 6888Xi cover down to expose the inner components.
- Disconnect the 10-pin ribbon cable from the I/O Board. A new cable is supplied in the replacement kit and should be used if the old one is damaged.
- Tag and disconnect wiring for Alarm Outputs, Flame Status Input and/or SPS, as applicable.
- Slide the I/O Board part way out of the 6888Xi enclosure.
- Disconnect the 4-position plug for the transmitter probe and output wiring. Remove the I/O Board completely from the 6888Xi enclosure.
- See Figure 5-3. Set jumpers JP1, JP2, JP5, JP7 and JP8 to their proper positions using the old I/O Board as a guide.
- Set switch SW4 to their proper positions using the old I/O Board as a guide.
- Partially slide the new I/O Board into the 6888Xi enclosure. Ensure the board is correctly aligned within the slots in the enclosure.
- Connect the 4-position plug for the transmitter probe and output wiring. Slide the I/O Board completely into the 6888Xi enclosure.
- Reinstall wiring for Alarm Outputs, Flame Status Input and/or SPS, as applicable. See Figure

FIGURE 6-4. I/O Board Wiring Connections

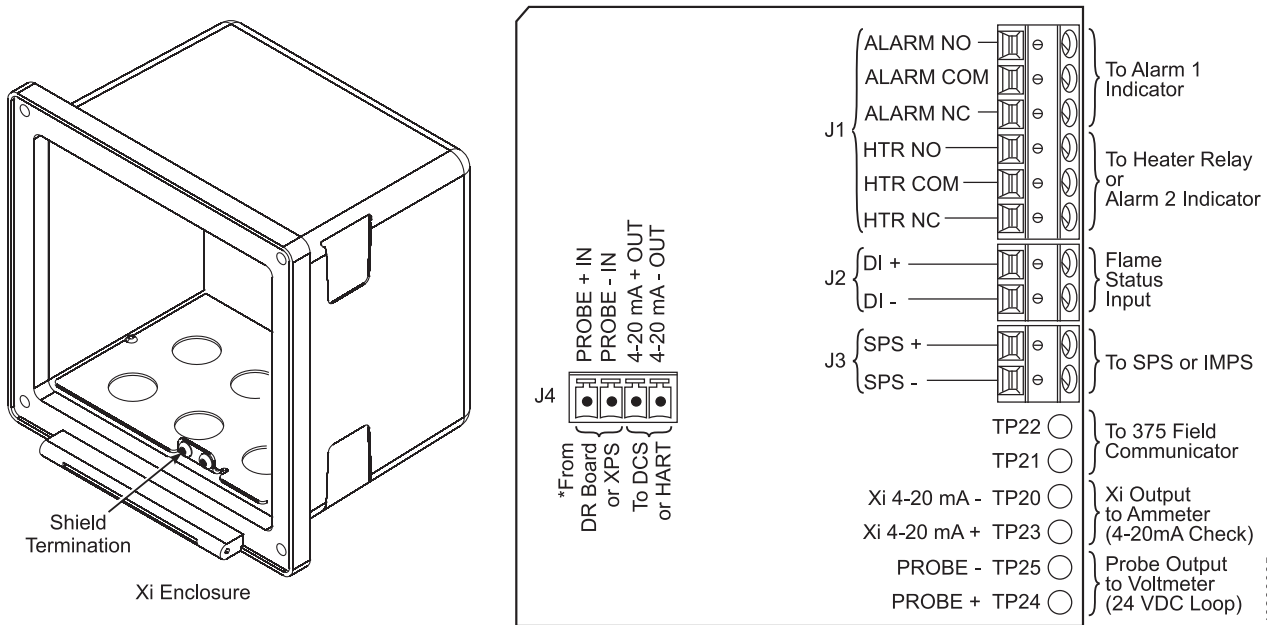
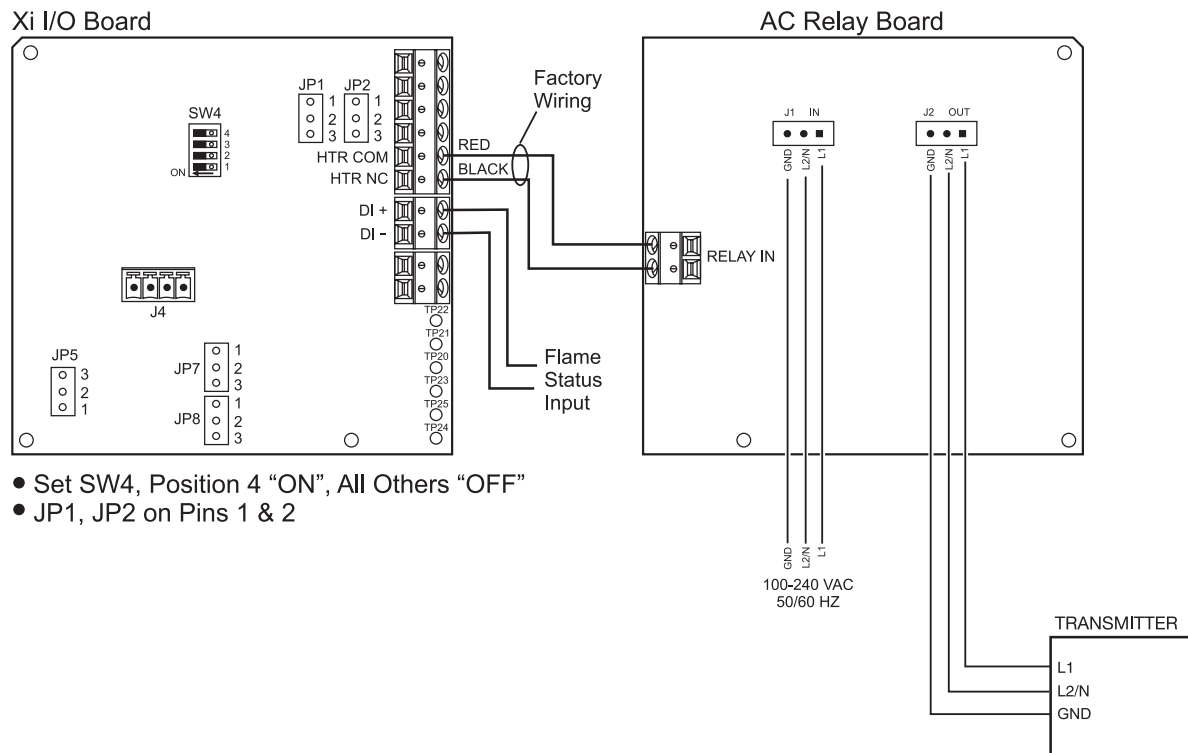
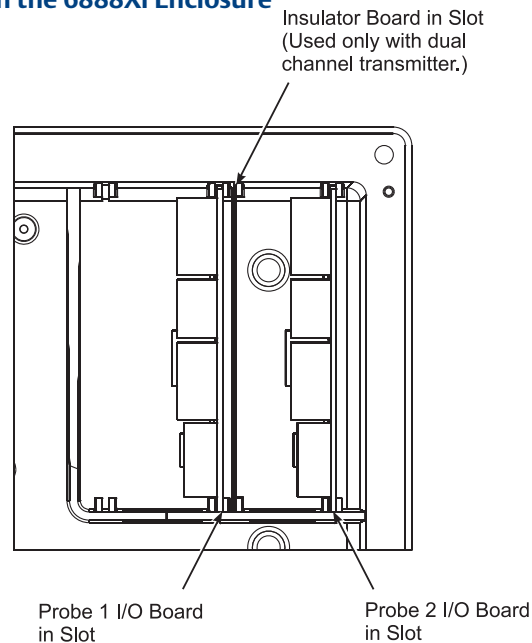

FIGURE 6-5. I/O Board Flame Safety Interlock Wiring



**FIGURE 6-6. I/O Board Positions in the 6888Xi Enclosure**



5-4 and Figure 5-5 for wiring diagrams. See Figure 5-6 for I/O board positions in the 6888Xi enclosure.

12. Connect the ribbon cable to the I/O Board. A new cable is supplied and should be used if the old one is damaged.
13. Swing the 6888Xi cover up in place and tighten the four screws.
14. Prior to operating the O<sub>2</sub> Probe and the 6888Xi, all optional software enhancements (previously enabled or not) must be enabled. Notify Rosemount Analytical Inc. and reference the following part numbers to enable the related software options:
15. Reapply power to the Remote Interface and Probe. When initialization is complete, the

Part Number	Description
6A00269G01	Enhanced Software Option Upgrade, Stoichiometric Function
6A00269G02	Enhanced Software Option Upgrade, Programmable Reference Function
6A00269G03	Enhanced Software Option Upgrade, Extended Temperature Function
6A00267604	Enhanced Software Option Upgrade, Diffuse Warning Function

**NOTE**

For enhanced software upgrades or to enable optional software features previously used in your 6888Xi configuration, contact Rosemount Analytical at 1-800-433-6076.

**NOTE**

The calibration parameters are stored in both the I/O Board and Transmitter Board. When the I/O Board is replaced, the calibration parameters must be either transferred from the Transmitter Board or the entire instrument must be recalibrated.

Probe will begin heating up, but an alarm condition will be shown. Prior to using the Transmitter for measurement purposes, perform one of the following:

- a. Recalibrate the O<sub>2</sub> Probe according to the applicable calibration instructions in Section 3.
- b. Synchronize the calibration parameters as follows:
  - i. Press the <DIAG> button once to view the alarms. A “Probe Changed” alarm will be shown.
  - ii. Press the <EXIT> button once to enter the “Diagnostic Menu”.
  - iii. Use the Up/Down keys to select “3-Acknowledge Alarms”. Press <ENTER>.
  - iv. Use the Up/Down keys to select “3-Ack Probe Changed”. Press <ENTER>.
  - v. Use the Up/Down keys to select “1-Get From Probe”. Press <ENTER> twice.
  - vi. When transfer is complete, press <EXIT> twice to return to the main menu.

## 6.5.2 AC relay board replacement

### WARNING

**Disconnect and lock out power before working on any electrical components.**

Use the procedure that follows to replace and set up the AC Relay board in the 6888Xi.

#### Replacing an 6888Xi AC Relay Board

1. Loosen the four screws securing the 6888Xi cover. The screws are captive and do not need to be completely removed.
2. Swing the 6888Xi cover down to expose the inner components.
3. Tag and disconnect wiring for the Relay In.
4. Slide the AC Relay Board part way out of the 6888Xi enclosure.
5. Tag and disconnect the two 3-position plugs for the AC input and transmitter probe heater wiring. Remove the AC Relay Board completely from the 6888Xi enclosure.
6. Partially slide the new AC Relay Board into the 6888Xi enclosure. Ensure the board is correctly aligned within the slots in the enclosure.
7. Connect the two 3-position plugs for the AC input and transmitter probe heater wiring. Slide the AC Relay Board fully into the 6888Xi enclosure.
8. Reinstall wiring for Relay In. See Figure 5-7 for wiring diagram.
9. Swing the cover up in place and tighten the four screws.

### CAUTION

**Installing and configuring an AC Relay Board for the Flame Status Interlock function will dedicate alarm output 2 for this function. Once configured for Flame Status Interlock, the software will override any previous alarm assignments for alarm output 2 and not allow it to be used for any other function.**

FIGURE 6-7. I/O & AC Relay Board Flame Safety Interlock Wiring

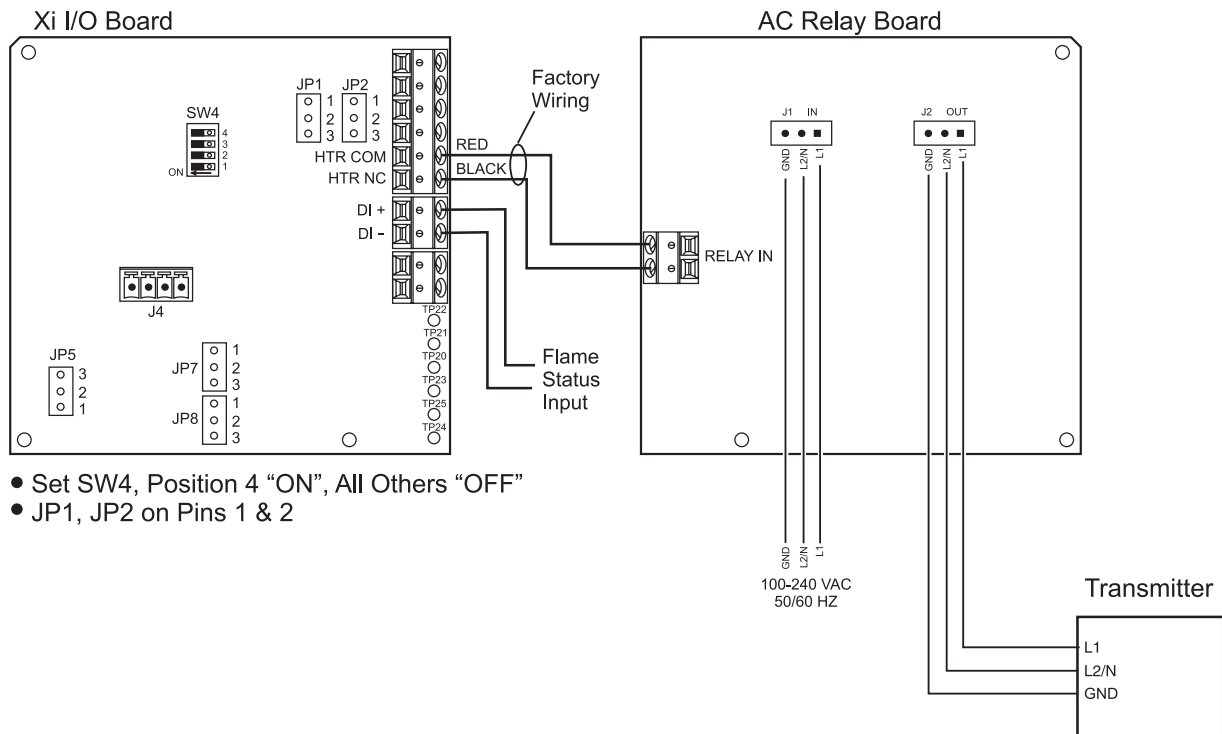

### Adding an AC Relay Board to the 6888Xi

1. Loosen the four screws securing the 6888Xi cover. The screws are captive and do not need to be completely removed.
2. Swing the 6888Xi cover down to expose the inner components.
3. Slide the I/O Board part way out of the 6888Xi enclosure.
4. Make the following jumper and switch settings:
  - a. Set SW4, Position 4 "ON" and all other positions "OFF".
  - b. Move the jumpers for both JP1 and JP2 to pins 1 and 2.
5. The I/O Board must be relocated to the right-most slot inside the 6888Xi enclosure. If there is enough service loop on the 6888Xi wiring, slide the I/O Board completely out of the enclosure and re-install it in the right-most slot. Ensure the board is correctly aligned within the slots. See Figure 5-8 for the correct location of the I/O Board.

### NOTE

An AC Relay Board can only be added to single channel 6888Xi, i.e. only one I/O Board controlling one O2 Probe. The Flame Status Interlock function requires a contact closure on the digital input of the I/O Board to indicate a flame is present. When properly connected and configured, AC power will be applied to the transmitter only when the flame is present.

6. If there is not sufficient wiring, tag and disconnect all wiring, and relocate the board. Then reinstall the wiring.

7. Partially slide the AC Relay Board into the left-most slot of the 6888Xi enclosure. The component side of the AC Relay board will be to the right with the fuse holder at the top. Ensure the board is correctly aligned within the slots in the enclosure. See Figure 5-8 for the correct location of the AC Relay Board.
8. Connect two wires approximately 6" long each between the "HTR COM" and the "HTR NC" connections on the I/O Board and the "RELAY IN" connections on the AC Relay Board; observe polarity. See Figure 5-7 for wiring details.
9. Connect the flame status indicator contact to the "DI+" and "DI-" on the AC Relay Board. See Figure 5-7 for wiring details.
10. Connect the AC input and output wiring to the Transmitter. See Figure 5-7 for wiring details.
11. Slide the AC Relay Board completely into the 6888Xi enclosure.
12. Swing the cover up in place and tighten the four screws.

### 6.5.3 Power supply board replacement

**⚠ WARNING**

**Disconnect and lock out power before working on any electrical components.**

Use the procedure that follows to replace the Power Supply board in the 6888Xi. Use this procedure to replace an original Linear Power Supply board or the current configuration Switching Power Supply board.

1. Loosen the four screws securing the 6888Xi cover. The screws are captive and do not need to be completely removed.
2. Swing the 6888Xi cover down to expose the inner components.
3. Refer to the wiring diagram in Figure 5-9. Unplug the AC input wiring plug from the Power Supply board. A new plug is supplied in the replacement kit and should be used if the 6888Xi plug is damaged.
4. Disconnect the 14-pin ribbon cable from the Power Supply board.
5. Remove the two long screws that secure the bracket (9, Figure 5-1) to the 6888Xi enclosure.
6. Hold the AC input wiring to the right and slide the Power Supply board out of the 6888Xi enclosure.

**FIGURE 6-8. I/O and AC Relay Board Position in 6888Xi Enclosure**

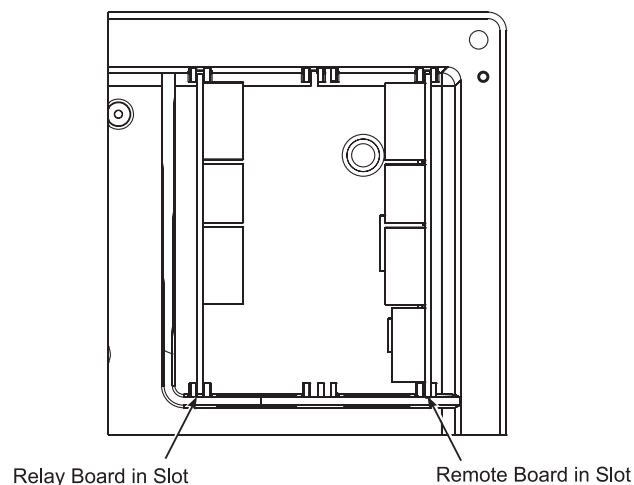
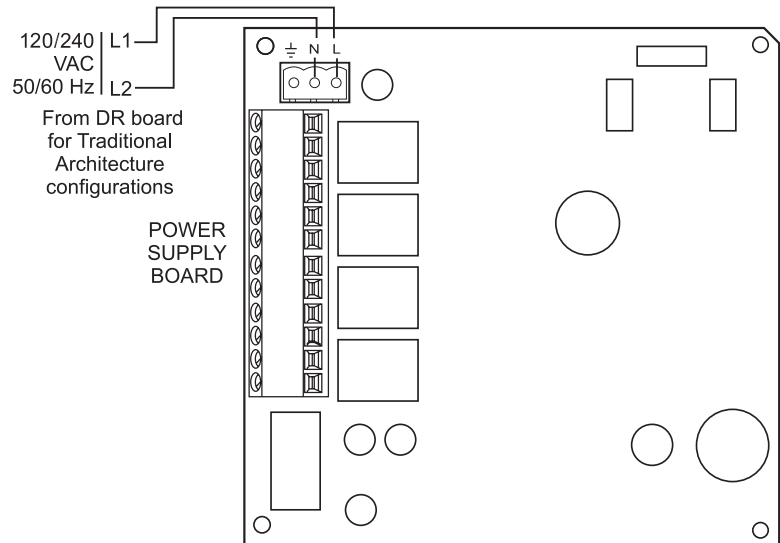

FIGURE 6-9. Power Supply Board Wiring



7. Install the new mounting bracket (9, Figure 5-1) on the new Power Supply board (10, Figure 5-1). A new bracket and mounting screws are provided in the replacement kit.
8. Slide the Power Supply board into the mating slots in the 6888Xi Enclosure. Make sure the board is correctly aligned in the slots.
9. Install and tighten the bracket mounting screws. Two new screws are provided in the replacement kit and should be used if the 6888Xi screws are damaged.
10. Connect the ribbon cable to the Power Supply board. A new ribbon cable (7, Figure 5-1) is provided in the replacement kit and should be used if the 6888Xi cable is damaged.
11. Connect the AC power plug to the Power Supply board.
12. Swing the 6888Xi cover up and tighten the four mounting screws.

## 6.5.4 Front panel replacement

### WARNING

Disconnect and lock out power before working on any electrical components.

Use the procedure that follows to replace the front panel on the 6888Xi. Replacement kits with and without the CPU board are available. Use the instructions that apply to the replacement kit you have.

#### Replacing Front Panel Assembly without CPU Board

1. Loosen the four screws securing the 6888Xi cover. The screws are captive and do not need to be completely removed.
2. Swing the 6888Xi cover down to expose the inner components.
3. Disconnect the 14-pin ribbon cable going to the Power Supply board. A new cable is supplied in the replacement kit and should be used if the old one is damaged.
4. Disconnect the 10-pin ribbon cable(s) going to the I/O Board(s). One new cable is supplied in the replacement kit and should be used if either of the ribbon cables are damaged.



 **WARNING**

**Installing and configuring an AC Relay Board for the Flame Status Interlock function will dedicate alarm output 2 for this function. Once configured for Flame Status Interlock, the software will override any previous alarm assignments for alarm output 2 and not allow it to be used for any other function.**

5. Remove the wire hinge from the right side of the 6888Xi cover. A paper clip or similar device can be inserted into the hole on the left side of the cover to push the hinge out of the cover. A new hinge pin is supplied in the replacement kit and should be used if the old one is damaged.
6. Position the new front panel assembly in place and reinstall the hinge pin. Ensure the hinge pin is fully seated into the 6888Xi cover.
7. The keypad window on the new front panel may be supplied with interior and exterior protective membranes. Remove the protective membranes prior to final assembly and use of the 6888Xi enclosure.
8. Reconnect the 10-pin ribbon cable from the I/O Board.
9. Reconnect the 14-pin ribbon cable from the Power Supply Board.
10. Swing the 6888Xi cover up in place and tighten the four screws.
11. If necessary, reconfigure the appearance of the main display. Refer to Section 3: Configuration, Startup and Operation.

### Replacing Front Panel Assembly without CPU Board

**NOTE**

**Prior to disassembly, observe the position of the plastic bumper with rubber insert as it is installed over the CPU board. The two longer screws are used on the top edge of the CPU board passing through the bumper.**

1. Loosen the four screws securing the 6888Xi cover. The screws are captive and do not need to be completely removed.
2. Swing the 6888Xi cover down to expose the inner components.
3. Disconnect the 14-pin ribbon cable going to the Power Supply board. A new cable is supplied in the replacement kit and should be used if the old one is damaged.
4. Disconnect the 10-pin ribbon cable(s) going to the I/O Board(s). One new cable is supplied in the replacement kit and should be used if either of the ribbon cables are damaged.
5. Remove the wire hinge from the right side of the 6888Xi cover. A paper clip or similar device can be inserted into the hole on the left side of the cover to push the hinge out of the cover. A new hinge pin is supplied in the replacement kit and should be used if the old one is damaged.
6. Place the front panel assembly on the bench. Remove the 4 screws securing the CPU board to the front cover.
7. Lift the CPU board off of the front cover using care not to damage the board.
8. Disconnect the keypad overlay ribbon cable from the CPU board. Discard the used front cover with the keypad overlay attached.

 **CAUTION**

**The new front panel assembly may be supplied with protective clear membranes over the interior and exterior of the window. Failure to remove the exterior protective membrane may cause the display to appear distorted. The membrane may be difficult or impossible to remove after extended use at elevated temperatures.**

9. The keypad window on the new front panel may be supplied with interior and exterior protective membranes. Remove the protective membranes prior to final assembly and use of the 6888Xi enclosure.

#### NOTE

**Prior to assembly, it is recommended that the inside of the keypad overlay window and LCD display window be gently cleaned to remove fingerprints and accumulated dust.**

10. Clean the inside of the keypad overlay window and LCD display window to remove fingerprints and accumulated dust. Use only a soft cloth; do not use any detergents or chemicals.
11. Connect the keypad overlay ribbon cable on the new front panel assembly to the CPU board. Use care not to damage the board.
12. Position the CPU board in place in the front panel assembly.
13. Reinstall the bumper and 4 screws to secure the CPU board in place. The two longer screws are used with the plastic bumper on the top edge of the CPU board.
14. Position the front panel assembly and reinstall the hinge pin. Ensure the hinge pin is fully seated into the 6888Xi cover.
15. Reconnect the 10-pin ribbon cable from the I/O Board.
16. Reconnect the 14-pin ribbon cable from the Power Supply Board.
17. Swing the 6888Xi cover up in place and tighten the four screws.
18. If necessary, reconfigure the appearance of the main display. Refer to Section 3: Configuration, Startup and Operation.

## 6.5.5 DR board replacement

#### WARNING

**Disconnect and lock out power before working on any electrical components.**

Use the procedure that follows to replace the DR board in the 6888Xi that is connected to a Direct Replacement probe.

1. Loosen the four screws securing the 6888Xi cover. The screws are captive and do not need to be completely removed.
2. Swing the 6888Xi cover down to expose the inner components.
3. Slide the DR board part way out of the 6888Xi enclosure.
4. Unplug the wiring harness plug from the connector J8 located on the bottom, left-hand side of the board. Refer to Figure 5-10.
5. Unplug the wiring harness plugs from the connectors J1, J2, and J3 located on the top, right-hand side of the board. Refer to Figure 6-11.
6. Tag and disconnect the wiring to connector J4.
7. Remove the DR board from the 6888Xi enclosure.
8. Partially slide the new DR board into the mating slots in the 6888Xi Enclosure. Make sure the board is correctly aligned in the slots.
9. Refer to the wiring diagram in Figure 6-10. Reconnect the wiring to connector J4.
10. Connect the wiring harness plugs to connectors J1, J2, J3, and J8.
11. Slide the DR board completely into the 6888Xi enclosure.

#### NOTE

**The calibration parameters are stored in both the I/O Board and Transmitter Board. When the I/O Board is replaced, the calibration parameters must be either transferred from the Transmitter Board or the entire instrument must be recalibrated.**

12. Reapply power to the Remote Interface and Probe. When initialization is complete, the Probe will begin heating up, but an alarm condition will be shown. Prior to using the Transmitter for measurement purposes, perform one of the following:
  - a. Recalibrate the O<sub>2</sub> Probe according to the applicable calibration instructions in Section 3.
  - b. Synchronize the calibration parameters as follows:
    - i. Press the <DIAG> button once to view the alarms. A “Probe Changed” alarm will be shown.
    - ii. Press the <EXIT> button once to enter the “Diagnostic Menu”.
    - iii. Use the Up/Down keys to select “3-Acknowledge Alarms”. Press <ENTER>.
    - iv. Use the Up/Down keys to select “3-Ack Probe Changed”. Press <ENTER>.
    - v. Use the Up/Down keys to select “1-Get From Probe”. Press <ENTER> twice.
    - vi. When transfer is complete, press <EXIT> twice to return to the main menu.

FIGURE 6-10. DR Board Wiring, Right-Hand Side

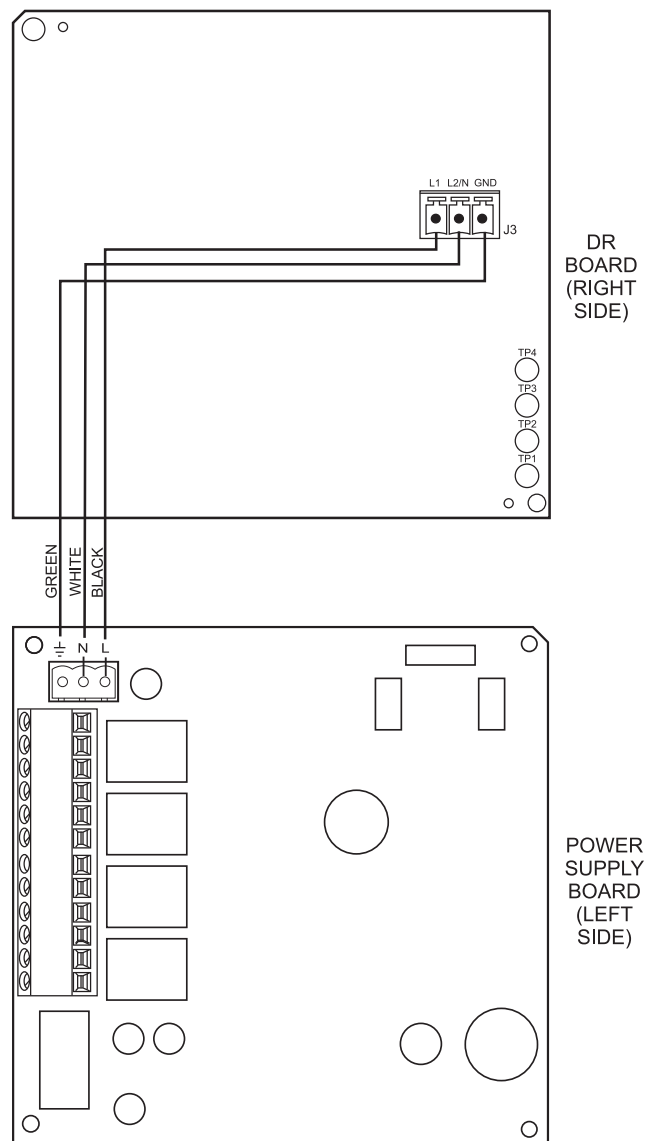
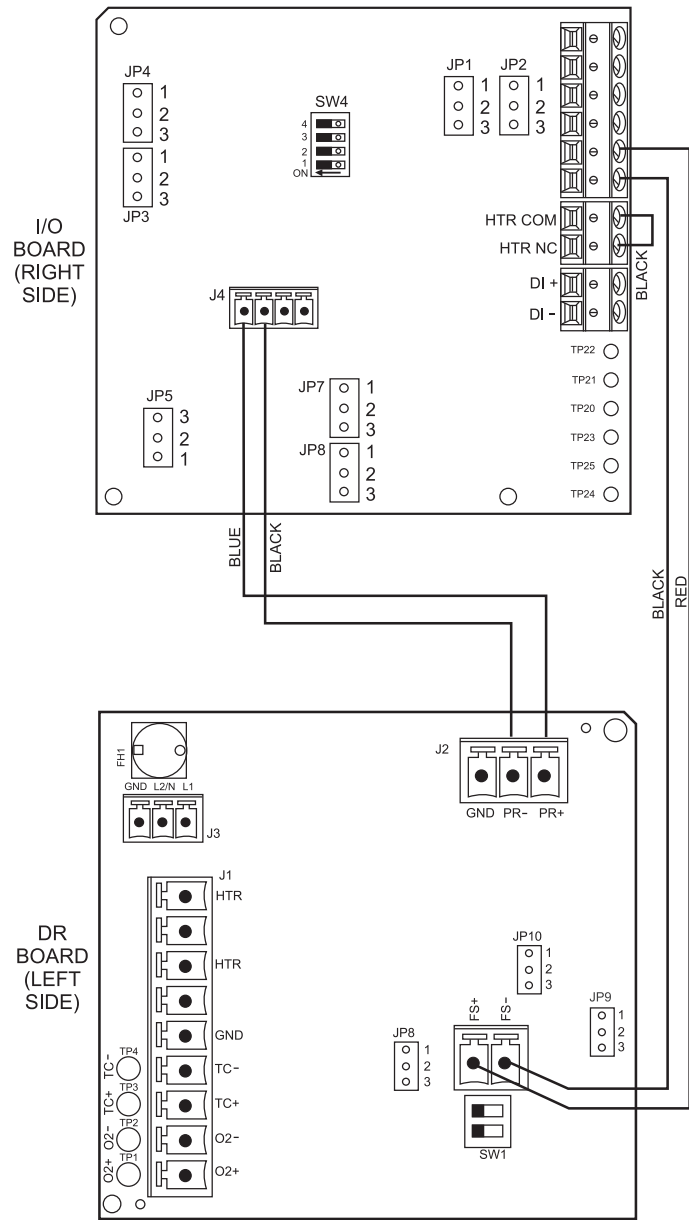

FIGURE 6-11. DR Board Wiring, Left-Hand Side



## Section 7: Replacement parts

### 7.1 Rosemount 6888Xi electronics

**TABLE 7-1. Replacement Parts for Rosemount 6888Xi**

Part Number	Description
6A00329G01	Kit, Switching Power Supply Board
6A00445G01	Kit, I/O Board*
6A00267G01	Kit, AC Relay Board
6A00446G01	Kit, DR Board
6A00447G01	Kit, Front Panel with Overlay & CPU Board
6A00447G02	Kit, Front Panel with Overlay
6A00269G01	Enhanced Software Option Upgrade, Stoichiometric Function
6A00269G02	Enhanced Software Option Upgrade, Programmable Reference Function
6A00269G03	Enhanced Software Option Upgrade, Extended Temperatures Function
6A00269G04	Enhanced Software Option Upgrade, Diffuser Warning Function
6A00237H24	Kit, Pipe & Wall Mount
6A00237H33	Kit, Panel Mount
6A00243G01	Ribbon Cable, 10 Pin (CPU Board to I/O Board)
6A00242G01	Ribbon Cable, 14 Pin (CPU Board to Power Supply Board)
6A00291H01	Insulator
6A00381G01	Kit, Hole Plug & Gland
6A00285H01	Gasket, Panel
6A00287H01	Gasket, Cover

\*Note: If the existing I/O Board has been operated with the Stoichiometric enhanced software feature, this feature must be activated in the new board before the 6888Xi is put back into service. Failure to do so will cause a false analog output signal to the DCS.

### 7.2 Calibration components

**TABLE 7-2. Replacement Parts for Calibration Components**

Part Number	Description
1A99119G01	Calibration Gas Bottles - 0.4% and 8% O <sub>2</sub> , balance nitrogen - 550 liters each*
1A99119G02	Two Flow Regulators (for calibration gas bottles)
1A99119G03	Bottle rack

\*Note: Calibration gas bottles cannot be shipped via airfreight



## Section 8: Optional accessories

### 8.1 HART® Handheld 375/475 Field Communicator

The 375/475 Field Communicator is an interface device that provides a common communication link to HART-compatible instruments, such as the 6888Xi. HART Communications Protocol permits all the information available from the 6888Xi's electronics to be transmitted over standard 4-20 mA signal wires. By attaching the 375/475 Field Communicator at a termination point along the

4-20 mA signal line, a technician can diagnose problems and configure and calibrate the 6888Xi as if he or she were standing in front of the instrument.

For more information, call Rosemount Analytical at 1-800-433-6076.

**FIGURE 8-1. 375/475 Field Communicator**

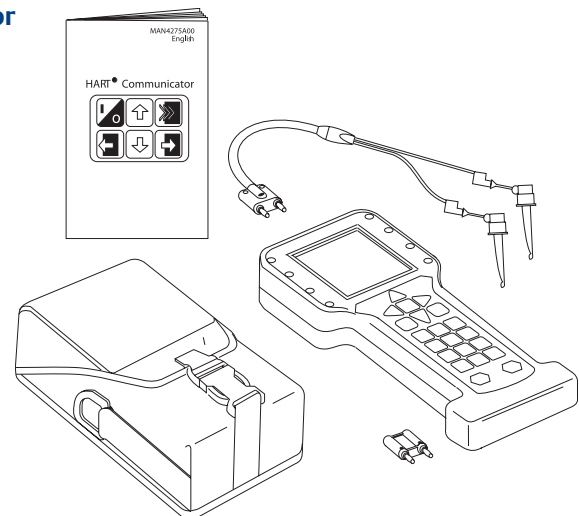

### 8.2 Asset Management Solutions (AMS) software

Asset Management Solutions (AMS) software works in conjunction with the HART Communication Protocol and offers the capability to communicate with all HART plant devices from a single computer terminal.

For more information, call Rosemount at 1-800-433-6076.

### 8.3 By-pass packages

The specially designed Rosemount By-Pass Package for oxygen analyzers has proven to withstand the high temperatures in process heaters while providing the same advantages offered by the in situ sensor. Inconel steel tubes provide effective resistance to corrosion, and the package uses no moving parts, air pumps, or other components common to other sampling systems.

For more information, call Rosemount at 1-800-433-6076.

## 8.4 Rosemount SPS 4001B Single Probe Autocalibration Sequencer

Rosemount Analytical Inc. specifically designed the SPS 4001B Single Probe Autocalibration Sequencer to provide the capability to perform automatic or on-demand calibrations. The SPS 4001B is fully enclosed in a NEMA cabinet suited for wall-mounting. This cabinet provides added protection against dust and minor impacts.

The SPS 4001B works in conjunction with the 6888Xi, eliminating out-of-calibration occurrences and the need to send a technician to the installation site.

For more information, call Rosemount Customer Support at +1 855 724 2628

FIGURE 8-2. SPS 4001B

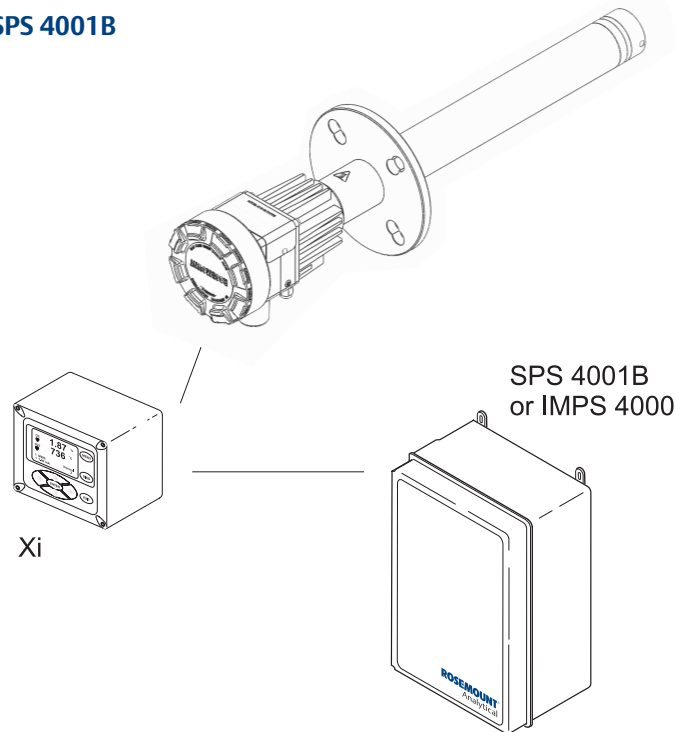



## 8.5 O<sub>2</sub> calibration gas

Rosemount Analytical's O<sub>2</sub> Calibration Gas and Service Kits have been carefully designed to provide a more convenient and fully portable means of testing, calibrating, and servicing.

Rosemount Analytical's oxygen analyzers. These lightweight, disposable gas cylinders eliminate the need to rent gas bottles.

For more information, call Rosemount Customer Support at +1 855 724 2628

**FIGURE 8-3. Calibration Gas Bottles**

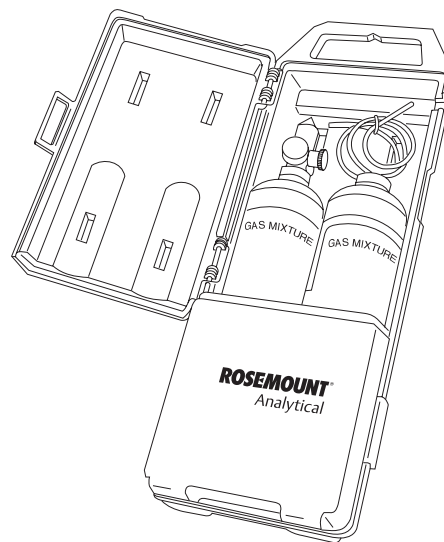

## 8.6 Oxybalance Display and Averaging System

Optional OxyBalance Display and Averaging System. Reviews up to eight 4-20 mA signals from individual probes. Trends individual outputs, calculates four programmable averages as additional 4-20 mA outputs.

For more information, call Rosemount Customer Support at +1 855 724 2628

---

**FIGURE 8-4. OxyBalance System**

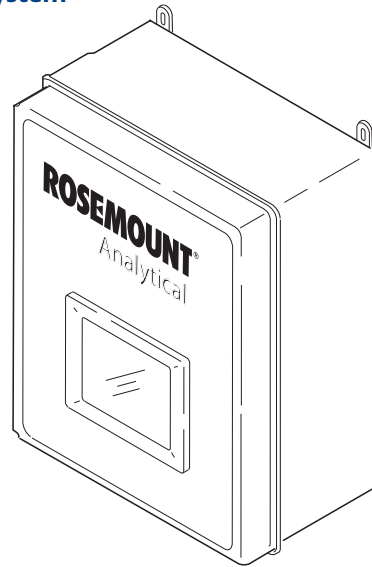

## Appendix A: Safety data



### IMPORTANT

#### SAFETY INSTRUCTIONS FOR THE WIRING AND INSTALLATION OF THIS APPARATUS

The following safety instructions apply specifically to all EU member states. They should be strictly adhered to in order to assure compliance with the Low Voltage Directive. Non-EU states should also comply with the following unless superseded by local or National Standards.

1. Adequate earth connections should be made to all earthing points, internal and external, where provided.
2. After installation or troubleshooting, all safety covers and safety grounds must be replaced. The integrity of all earth terminals must be maintained at all times.
3. Mains supply cords should comply with the requirements of IEC227 or IEC245.
4. All wiring shall be suitable for use in an ambient temperature of greater than 75°C.
5. All cable glands used should be of such internal dimensions as to provide adequate cable anchorage.
6. To ensure safe operation of this equipment, connection to the mains supply should only be made through a circuit breaker which will disconnect all circuits carrying conductors during a fault situation. The circuit breaker may also include a mechanically operated isolating switch. If not, then another means of disconnecting the equipment from the supply must be provided and clearly marked as such. Circuit breakers or switches must comply with a recognized standard such as IEC947. All wiring must conform with any local standards.
7. Where equipment or covers are marked with the symbol to the right, hazardous voltages are likely to be present beneath. These covers should only be removed when power is removed from the equipment - and then only by trained service personnel.
8. Where equipment or covers are marked with the symbol to the right, there is a danger from hot surfaces beneath. These covers should only be removed by trained service personnel when power is removed from the equipment. Certain surfaces may remain hot to the touch.
9. Where equipment or covers are marked with the symbol to the right, refer to the Operator Manual for instructions.
10. All graphical symbols used in this product are from one or more of the following standards: EN61010-1, IEC417, and ISO3864.
11. Where equipment or labels are marked "Do Not Open While Energized" or similar, there is a danger of ignition in areas where an explosive atmosphere is present. This equipment should only be opened when power is removed and adequate time as specified on the label or in the instruction manual has been allowed for the equipment to cool down and then only by trained service personnel.

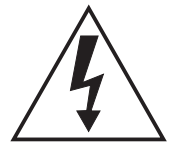

# Appendix B: Return of material

## B.1 Returning material

### SERVICE SUPPORT

To expedite the return process outside of the United States, contact the nearest Emerson representative. Within the United States, call the Emerson Instrument and Valves Response Center using the 1-800-654-RSMT (7768) toll-free number. This center, available 24 hours a day, will assist you with any needed information or materials. The center will ask for product model and serial numbers, and will provide a Return Material Authorization (RMA) number. The center will also ask for the process material to which the product was last exposed. Emerson Instrument and Valves Response Center representatives will explain the additional information and procedures necessary to return goods exposed to hazardous substances.

# Appendix C: Product certifications

## USA/Canada

### CSA

**Certificate:** 70130119

**Standards:** CAN//CSA C22.2 No. 61010-1-04, UL 61010-1:2004 (2nd Edition),  
CAN/CSA-C22.2 No.94-M91 (R2001), UL 50 (11th Ed.)  
CAN/CSA C22.2 No. 60529:05, IEC 60529 (Ed 2.1-2001-02), NEMA 250-2003





### Markings:

Type 4X

### Conditions of Acceptability

1. The unit is intended to be connected to supply mains by a qualified personal in accordance with national (e.g., CEC, NEC, etc) and local codes.
2. Suitable APPROVED switch and fuse or a circuit breaker shall be provided to facilitate the disconnection of mains power.
3. The maximum operating ambient is considered as follows: 50 degrees C for Xi Enhanced Remote Interface, Integral XPS and 6888 Xi Advanced Electronics.

# Appendix D: Declaration of Conformity

No: RAD1131 Rev. B		
	<h2>Declaration of Conformity</h2>	 / 
<p>We, <b>Rosemount Inc.</b> 6021 Innovation Blvd Shakopee, MN 55379 USA</p>		
<p>declare under our sole responsibility that the product,</p> <p style="text-align: center;"><b>Rosemount™ 6888 Advanced Electronics, Model 6888Xi</b></p>		
<p>Authorized Representative in Europe:</p> <p>Emerson S.R.L., company No. J12/88/2006, Emerson 4 street, Parcul Industrial Tetarom II, Cluj-Napoca 400638, Romania</p> <p>Regulatory Compliance Shared Services Department Email: <a href="mailto:europaeproductcompliance@emerson.com">europaeproductcompliance@emerson.com</a> Phone: +40 374 132 035</p>	<p>For product compliance destination sales questions in Great Britain, contact Authorized Representative:</p> <p>Emerson Process Management Limited at <a href="mailto:ukproductcompliance@emerson.com">ukproductcompliance@emerson.com</a> or +44 11 6282 23 64, Regulatory Compliance Department.</p> <p>Emerson Process Management Limited, company No 00671801, Meridian East, Leicester LE19 1UX, United Kingdom</p>	
<p>to which this declaration relates, is in conformity with:</p> <ol style="list-style-type: none"><li>1) the relevant statutory requirements of Great Britain, including the latest amendments, as shown in the attached schedule.</li><li>2) the provisions of the European Union Directives, including the latest amendments, as shown in the attached schedule.</li></ol>		
 _____ (signature & date of issue)	May 2, 2022	Mark Lee   Vice President, Quality   Boulder, CO, USA _____ (name) (function) (place of issue)
<p><b>EMC Directive (2014/30/EU)</b> Harmonized Standards: EN 61326-1:2013</p>	<p><b>Electromagnetic Compatibility Regulations 2016 (S.I. 2016/1091)</b> Designated Standards: EN 61326-1:2013</p>	
<p><b>Low Voltage Directive (2014/35/EU)</b> Harmonized Standards: EN 61010-1:2010</p>	<p><b>Electrical Equipment (Safety) Regulations 2016 (S.I. 2016/1101)</b> Designated Standards: EN 61010-1:2010</p>	

## Appendix E: China RoHS table

表格 1: 含有 China RoHS 管控物质超过最大浓度限值的部件型号列  
Table 1: List of Model Parts with China RoHS Concentration above MCVs

部件名称 Part Name	有害物质 / Hazardous Substances					
	铅 Lead (Pb)	汞 Mercury (Hg)	镉 Cadmium (Cd)	六价铬 Hexavalent Chromium (Cr +6)	多溴联苯 Polybrominated biphenyls (PBB)	多溴联苯醚 Polybrominated diphenyl ethers (PBDE)
电子组件 Electronics Assembly	X	O	O	O	O	O
传感器组件 Sensor Assembly	X	O	O	O	O	O

本表格系依据 SJ/T11364 的规定而制作。

This table is proposed in accordance with the provision of SJ/T11364

O: 意为该部件的所有均质材料中该有害物质的含量均低于 GB/T 26572 所规定的限量要求。

O: Indicate that said hazardous substance in all of the homogeneous materials for this part is below the limit requirement of GB/T 26572.

X: 意为在该部件所使用的所有均质材料里, 至少有一类均质材料中该有害物质的含量高于 GB/T 26572 所规定的限量要求。

X: Indicate that said hazardous substance contained in at least one of the homogeneous materials used for this part is above the limit requirement of GB/T 26572.

**For more information, see [Emerson.com](https://www.emerson.com)**

©2022 Emerson. All rights reserved.

The Emerson logo is a trademark and service mark of Emerson Electric Co. Rosemount is a mark of one of the Emerson family of companies. All other marks are the property of their respective owners.

The contents of this publication are presented for information purposes only, and while effort has been made to ensure their accuracy, they are not to be construed as warranties or guarantees, expressed or implied, regarding the products or services described herein or their use or applicability. All sales are governed by our terms and conditions, which are available on request. We reserve the right to modify or improve the designs or specifications of our products at any time without notice.