

# Replacement of Fisher™ FIELDVUE™ DVC6200 HC Digital Valve Controllers (Firmware 7) with DVC7K-H (Firmware 1)

## Table of Contents

- Management of Change .....2
- Background .....2
- Question and Answer Checklist .....2
- Comparison of Instruments with Firmware 7 to Instruments with Firmware 6 and Older .....4
- Required Updates to User Interface When Upgrading to DVC6200 Instruments with Firmware 7 .....7
- Frequently Asked Questions .....7
- Conclusion .....10



Figure 1. DVC7K (Firmware 1)

## Management of Change

Management of Change (MOC) is a procedure used to proactively manage changes that can potentially affect safety or general procedure within a process plant. Product changes often have a significant impact on plant efficiency throughout the transition period. In lieu of the complexity of completing an MOC approval process, this MOC Guide has been developed to prevent delays and difficulties while ensuring a successful product change.

## Background

To continue to increase the usefulness and value of the Fisher FIELDVUE digital valve controllers, additional features and functions have been implemented within the DVC7K. These additions include a Local User Interface available in thirteen configurable languages to enable tool free configuration and troubleshooting, an improved low power microprocessor for on board diagnostic analysis, additional on-board memory for field diagnostic capture and storage, battery backup to maintain instrument time and the addition of a position transmitter and two switches that can be used simultaneously.

This MOC Guide is not intended to be used as a stand-alone document. It must be used with the following documents, as applicable:

For the Fisher FIELDVUE DVC7K instrument:

- Instruction Manual for the DVC7K-H Digital Valve Controller ([D104767X012](#))
- Quick Start Guide for the DVC7K-H Digital Valve Controller ([D104766X012](#))

Contained in the following sections are design comparisons between the DVC7K instrument (FW1) and legacy DVC6200 instrument (FW7). These comparisons demonstrate how the design of technologies allows users to efficiently transition to new, more reliable Fisher products.

## Question and Answer Checklist

- 1. Q:** Does the proposed modification cause any changes to the piping and instrumentation diagram (P&ID)?  
**A:** Yes.
  
- 2. Q:** Does the proposed modification change process chemistry, technology or operating and control philosophies?  
**A:** No.
  
- 3. Q:** Have the operating and design limits of the proposed modification changed?  
**A:** Yes.

**4. Q:** Have the codes and standards to which the new equipment has been designed changed?

**A:** Yes.

**5. Q:** Does the proposed modification change the Hazardous Electrical Area classification?

**A:** Yes.

**6. Q:** Does the proposed modification change existing or create new demands for battery backup or other power supply redundancy or reliability?

**A:** No.

**7. Q:** Does the proposed modification introduce new equipment that needs to be operated and, has a new operations list been stated?

**A:** Yes.

**8. Q:** Does the proposed modification introduce new equipment items that require spare parts, training manuals, maintenance procedures or training to teach the maintenance department how to maintain them?

**A:** Yes.

**9. Q:** Does the proposed modification change the spares for existing pieces of equipment?

**A:** No.

**10. Q:** Does the proposed modification introduce new equipment items that require periodic predictive maintenance?

**A:** Yes.

## Comparison of DVC7K Firmware 1 with DVC6200 Firmware 7

**Table 1. FIELDVUE DVC7K Instrument Capabilities**

CAPABILITIES	DVC7K (FW1)	DVC6200 (FW7)
Housing Material	Copper-Free Aluminum	Aluminum
Paint	VOC Free Powder Coat	Wet Coat
Weight	3.9 kg / 8.9 lbs	3.5 kg / 7.7 lbs
Actuator Mounting Support	Integral mounting to Fisher 657/667 Integral mounting to Fisher Rotary Sliding Stem linear applications Quarter-turn rotary application IEC 60534-6-1 compliant actuators IEC 60534-6-2 compliant actuators VDI/VDE 3845 compliant actuators VDI/VDE 3847-1 and 2 NAMUR compliant actuators	Integral mounting to Fisher 657/667 Integral mounting to Fisher GX Integral mounting to Fisher Rotary Sliding Stem linear applications Quarter-turn rotary application IEC 60534-6-1 compliant actuators IEC 60534-6-2 compliant actuators VDI/VDE 3845 NAMUR compliant actuators
Travel Feedback	Linkageless Non-Contact	Linkageless Non-Contact
Conduit/Pneumatic Entries	Three 1/2" NPT / 1/4" NPT Three 1/2" NPT / G 1/4 Three M20 / G 1/4	Two 1/2" NPT / 1/4" NPT Two M20 / 1/4" NPT
Integral mounting 67CFR Regulator	Vertical Orientation	Horizontal Orientation
Pressure Gauges	Optional Gauge Block and Gauges	Optional Gauges
Standard Temperature Construction	-40 to 80 °C / -40 to 176 °F	-40 to 85 °C / -40 to 180 °F
Extreme Temperature Construction	-45 to 80 °C / -67 to 176 °F	-52 to 85 °C / -67 to 180 °F
Termination Hardware	Cage Clamp without Output Option Cage Clamp with Output Option	Terminals without Output Option Cage Clamp with Output Option
LUI – Local User Interface	Full text configurable to 13 languages Guided setup Active Alert Recommended Actions	Not Available
Valve Health Status LED	NE107 Valve Health LED	Not Available
Instrument Clock Battery Backup	Available for Standard Temperature	Not Available

- continued -

## Comparison of DVC7K Firmware 1 with DVC6200 Firmware 7 (Continued)

**Table 1. FIELDVUE DVC7K Instrument Capabilities (continued)**

CAPABILITIES	DVC7K (FW1)	DVC6200 (FW7)
Operation/Action	Single Acting, Direct Single Acting, Reverse Double Acting	Single Acting, Direct Single Acting, Reverse Double Acting
Low Bleed Relay	Available	Available
Power Source	4 to 20 mA DC 24 V DC (11 to 30 V DC at 8.5 mA)	4 to 20 mA DC Multi-Drop (11 to 30 V DC at 10 mA)
Setpoint Source	4 to 20 mA DC 24 V DC	4 to 20 mA DC
Minimum Voltage	10.2 V without HART 10.7 V with HART	9.5 V without HART 10 V with HART
Output Options	None 3 Outputs (1 Transmitter and 2 Switches)	None 1 Output (Transmitter or Switch)
Instrument Mode	Automatic, Manual	In Service, Out of Service
HART Burst Mode	Not Available	HART 7 Burst
HART Protocol	HART 7	HART 7 HART 5
Control Tiers	Throttling and On/Off On/Off Only	Throttling
Application Mode	Throttling On/Off	Not Available
Pressure Control and Fallback	Not Available	Available
Latch Behavior	None, Zero Power, Last Position	Not Available
Event Log	1000 entries	20 entries (Alerts Only)
Characterization	3 to 20 entry table	20 entry table
Specification Sheet	Fisher Specification Sheet ISA 20 Specification Sheet	Fisher Specification Sheet

- continued -

## Comparison of DVC7K Firmware 1 with DVC6200 Firmware 7 (Continued)

**Table 1. FIELDVUE DVC7K Instrument Capabilities (continued)**

CAPABILITIES	DVC7K (FW1)	DVC6200 (FW7)
Non-Volatile Memory Defect Alert	Available	Available
Volatile Memory Defect Alert	Available	---
Drive Signal Alert	Available	Available
Drive Current Alert	Available	Available
Transmitter Open Circuit Alert	Available	---
Electronic Defect Alert	Available	Available
Device Misconfigured Alert	Available	---
Instrument Time is Approximate Alert	Available	Available
Calibration in Progress Alert	Available	Available
Diagnostic in Progress Alert	Available	Available
Temperature High Alert	Available	---
Temperature Low Alert	Available	---
Loop Current Fixed Alert	Available	Available
Loop Current Saturated Alert	Available	Available
Instrument Mode Alert	Available	---
Travel Feedback Error Alert	Available	---
Travel Deviation Alert	Available	Available
Travel High Alert	Available	Available
Travel Low Alert	Available	Available
Travel Limit/Cutoff High Alert	Available	Available
Travel Limit/Cutoff Low Alert	Available	Available
Cycle Count High Alert	Available	Available
Travel Accumulator High Alert	Available	Available
Stroke Open Time Alert	Available	---
Stroke Close Time Alert	Available	---
Supply Pressure High Alert	Available	Available
Supply Pressure Low Alert	Available	Available
Pressure A Overpressurized Alert	Available	Available

## Required Updates to User Interface When Upgrading to DVC7K (FW1) from DVC6200 (FW7)

**Table 2. Device Description Requirements**

HART Communication Protocol	DVC7K (FW1)	DVC6200 (FW7)
HART 7	Device Revision 1, DD Rev 1	Device Revision 3, DD Rev 1
HART 5	Not Applicable	Device Revision 1, DD Rev 7

## Frequently Asked Questions

- Q:** Will there be new mountings for the DVC7K?











**A:** The DVC7K will use the same mountings as the DVC6200.
- Q:** Do I need to have different spare parts for the DVC7K?

**A:** Yes, some parts will change. However, the DVC7K shares the same I/P, Relay, magnetic array and mountings as the DVC6200.
- Q:** Can I configure my DVC7K with my current ValveLink software?

**A:** No, you cannot. However, you can set up your instrument with the Local User Interface (LUI) or using the Device Description (DD) on the Trex, your laptop using AMS Device Configurator or through any HART based Host System.
- Q:** How can I tell if there are active alerts in the DVC7K?

**A:** The LED will indicate if an alert is active. You can also see the active alerts, NE107 status and recommended actions on how to correct the alert from the LUI or using the DD. Figure 2 shows the NE107 Valve Health Indicators.

**Figure 2. NE107 Valve Health Indicators**

<b>Solid</b>			<b>Good</b>
<b>Blinking</b>			<b>Maintenance Required</b>
<b>Blinking</b>			<b>Out of Specification</b>
<b>Blinking</b>			<b>Check Function</b>
<b>Solid</b>			<b>Failed</b>

**5. Q:** Can I disable the buttons on the Local User Interface (LUI)?

**A:** Not for first release. However, the LED light can be disabled from the LUI. Additionally, there are protection methods planned for future releases to provide more restriction on access to the device both locally and remotely.

**6. Q:** Can I use the transmitter and switches at the same time?

**A:** Yes, if the DVC7K is ordered with the options package it will support a 4 to 20 mA position transmitter and two switches.

**7. Q:** Does the DVC7K maintain time during a power outage?

**A:** Yes, there is a battery backup onboard the instrument for the standard temperature and high temperature option. The extreme temperature option will not provide a battery backup of the instrument time.

**8. Q:** What pneumatic and electrical connections are available in the DVC7K?

**A:** There are three options for electrical and pneumatic connections:

- i. Imperial = 1/4" NPT electrical and 1/4" pneumatic
- ii. Metric = M20 electrical and G1/4 pneumatic
- iii. Metric/Imperial = M20 electrical and 1/4" pneumatic

**9. Q:** Does the DVC7K support multiple languages?

**A:** Yes, we will support 13 languages at initial release: Arabic, Chinese, Czech, English, French, German, Italian, Japanese, Korean, Polish, Portuguese, Russian and Spanish.

**10. Q:** Does the DVC7K support HART 5?

**A:** The device is HART 7 compliant. HART 7 is backwards compatible with most HART 5 systems. The main difference between HART 7 and HART 5 is that with HART 5 you will not have access to the Long Tag. You will be limited to the 8 characters that you are limited to in your current HART 5 device.



**11. Q:** How will I do firmware upgrades, and how long will it take?

**A:** Upgrading to firmware 2 will require a specific cable to download the new firmware. It is estimated to take around two to three minutes and requires the instrument to be in Manual Mode.

After the implementation of Bluetooth® wireless technology and if Bluetooth is enabled on the device, future firmware upgrades can also be done on a Trex, tablet or phone utilizing the Emerson Bluetooth App.

**12. Q:** Is the On/Off Control Tier a different DVC7K?

**A:** The DVC7K has two Control Tiers. The Control Tier determines the control available for the instrument.

- Throttling Control (TC): Supports Throttling and On/Off Application Modes
- Discrete Control (DC): Supports On/Off Application Mode

**13. Q:** Does the On/Off Control Tier have a SIL certificate?

**A:** No, this is not for SIL rated applications. This is only for On/Off applications. An SIS DVC7K is on the roadmap but not part of first release.

**14. Q:** Are there new alerts for the On/Off Control Tier?

**A:** Yes, there are stroke time degradation alerts that can be configured in the instrument.

**15. Q:** What are the differences in the pneumatic ports and electrical conduit entry points between the DVC7K and DVC6200 along the X, Y and Z axes?

**A:**

DVC7K PORT	AXIS, MM / IN.		
	X	Y	Z
Supply Port	3.77 mm / 0.148 in.	-25.65 mm / -1.01 in.	39.01 mm / 1.54 in.
Port A	-10.24 mm / -0.40 in.	-24.08 mm / -0.95 in.	-40.31 mm / -1.59 in.
Port B	-10.24 mm / -0.40 in.	50.56 mm / 1.99 in.	-40.31 mm / -1.59 in.
Lower, Left Electrical Conduit Entry	18.28 mm / 0.72 in.	-34.07 mm / -1.34 in.	13.92 mm / 0.55 in.

Figure 3. DVC6200 Perspective Drawing

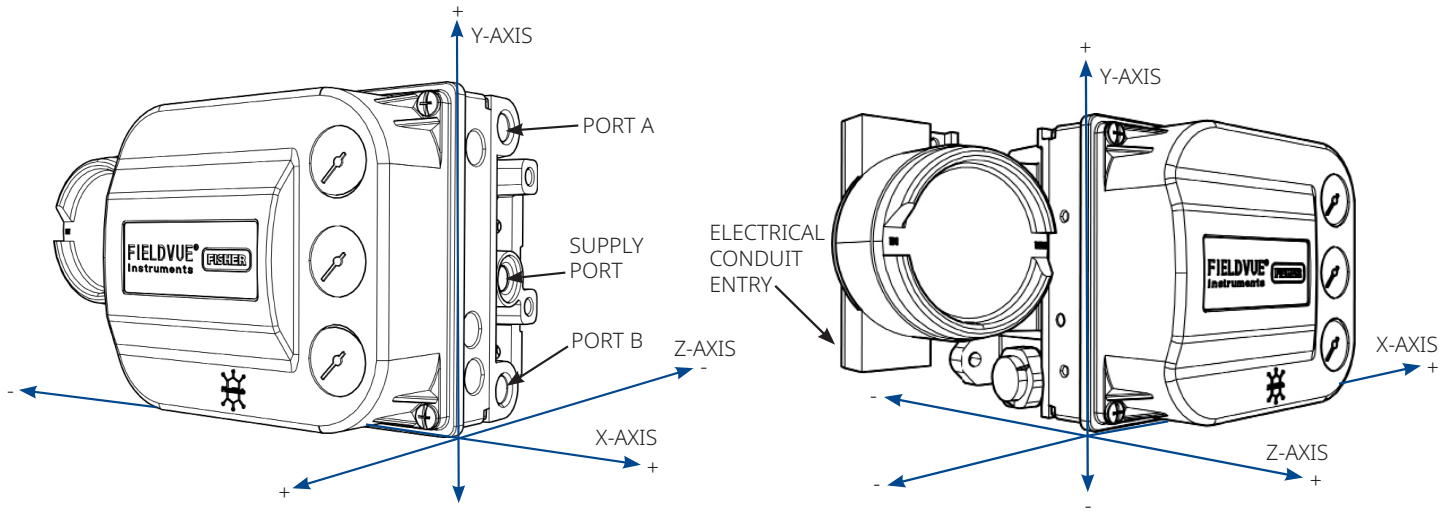

## Conclusion

The Fisher FIELDVUE DVC7K digital valve controller continues to be the most reliable digital valve controller in production. The design philosophy allows the user the flexibility to transition to the current DVC7K instrument minimizing MOC approval documents.

Please refer to the Fisher FIELDVUE DVC7K digital valve controller product bulletins, quick start guide and instruction manuals, available from your local [Emerson sales office](#), for complete features.



Fisher.com



Facebook.com/FisherValves



LinkedIn.com/groups/3941826



X.com/FisherValves

D353380X012 © 2023, 2025 Fisher Controls International LLC. All rights reserved.

**Neither Emerson, nor any of its affiliated entities assume responsibility for the selection, use or maintenance of any product. Responsibility for proper selection, use, and maintenance of any product remains solely with the purchaser and end user.**

Fisher, FIELDVUE, and ValveLink are marks owned by one of the companies in the Emerson business unit of Emerson Electric Co. Emerson and the Emerson logo are trademarks and service marks of Emerson Electric Co. All other marks are the property of their respective owners.

The contents of this publication are presented for informational purposes only, and while every effort has been made to ensure their accuracy, they are not to be construed as warranties or guarantees, express or implied, regarding the products or services described herein or their use or applicability. All sales are governed by our terms and conditions, which are available upon request. We reserve the right to modify or improve the designs or specifications of such products at any time without notice.

Emerson  
Marshalltown, Iowa 50158 USA  
Sorocaba, 18087 Brazil  
Cernay, 68700 France  
Dubai, United Arab Emirates  
Singapore 128461 Singapore

[www.Fisher.com](http://www.Fisher.com)

**FISHER™**

