

# ASCO®

## Redundant Control System

### Operation & Maintenance Guide

THIS DOCUMENT CONTROLLED BY  
RCS Ex CERTIFICATION



# **Operation & Maintenance Guide**



## **Redundant Control System**

### **Table of Contents**

<b>Product Description</b>	<b>3</b>
<b>ATEX Environmental Ratings</b>	<b>4</b>
<b>General Specifications</b>	<b>4</b>
<b>Nameplate Information (ATEX Versions Only)</b>	<b>5</b>
<b>Section 1-Normally Closed</b>	<b>7</b>
1. General Operation	7
2. Testing and Maintenance	9
<b>Section 2-Normally Open</b>	<b>10</b>
1. General Operation	10
2. Testing and Maintenance	11
<b>Section 3-Double Acting</b>	<b>12</b>
1. General Operation	12
2. Testing and Maintenance	13
<b>Section 4</b>	<b>14</b>
1. Functional Test Certification	14
2. Spare Parts	14
3. Packaging	14
4. Limited Warranty	14
5. Tools Required for Routine Service	14
RCS Base Unit Wiring Diagram (A)	15
RCS Base Unit with PLC Wiring Diagram (B)	16
RCS N.C. Piping Diagrams	17
RCS N.O. Piping Diagrams	18

## Documentation Conventions

This guide uses the following typographic conventions:

<b>EXAMPLE NOTE</b>	<b>Description</b>
	<i>Notes containing supplementary information.</i>
	<i>This symbol precedes information about potential equipment damage.</i>
	<i>This symbol precedes information about potential personnel hazards.</i>

## User Experience Prerequisites

To effectively use the Pneumatic RCS, users should have some experience with pneumatic systems.

## Warnings!

**READ THIS ENTIRE MANUAL AND ALL RELATED PUBLICATIONS PERTAINING TO THE WORK TO BE PERFORMED BEFORE INSTALLING, OPERATING OR SERVICING THIS EQUIPMENT.**

- Follow all appropriate safety codes and standards.
- Failure to follow instructions may result in personal injury and/or property damage.
- Use extreme caution when working around power-input cables. These cables may have potentially lethal or dangerous voltages.
- Prior to energizing the equipment, have qualified personnel verify all wiring and connections against vendor drawings. Incorrect wiring and/or connections can result in equipment damage or serious system failure. If you have questions or

need more information on installing and operating ASCO equipment, contact ASCO.

## OPERATIONAL ATMOSPHERE CONSIDERATIONS:

The ATEX version of the Redundant Control System (hereafter referred to as RCS) is designed in accordance with Annex II of the European Directive 2014/34/EU, and European standards EN 60079-0:2012 + A11:2013, EN 60079-1:2014, EN 60079-7:2015, and EN 60079-18:2015. Classification : Ex II 2G Ex db eb mb IIC Gb IP-56.

## MODELS COVERED BY ATEX APPROVAL:

ATEX Approval applies to RCS products having an ASCO Part Number beginning with "5RC", and that contain any combination of the following features:

**Manifold Architecture:** Normally Closed, Normally Open, or Double Acting.

**Enclosure Material:** 304 SS, 316 SS

**System Voltage:** 12 VDC, 24 VDC, 48 VDC, 120 VDC, 110/50-120/60, 230/50-240/50

**Operational Mode:** Energized to trip or De-energized to trip

**Optional Features:** Common Alarm, Local Initiation of SOV test, Local Initiation of Partial Stroke test, Bypass indication, Silver Contact for relay logic or Lever type bypass switch.

**User defined lights and push buttons:** Any combination of standard catalog lights and push buttons.

## Options not covered by ATEX Approval:

- RCS products having an ASCO Part Number beginning with "5RC" that include Local Manual Reset or a Composite Enclosure
- RCS units containing a PLC

## PRODUCT DESCRIPTION

The RCS is a two-out-of-two (2oo2) or one-out-of-one hot standby (1oo1 HS) voting, solenoid-operated valve system designed for use as a component in safety instrumented systems. It functions as a redundant pneumatic tripping device to control the pilot air signal to a process valve actuator. The RCS uses 2oo2 or 1oo1 HS voting solenoids to enhance the reliability of the circuit. The RCS consists of two electrically actuated solenoid valves (SOV1, SOV2) and a pneumatically operated (Manually Controlled) bypass valve, and three pressure switches. The pressure switches provide solenoid state feedback and are used during on-line testing of the RCS unit. The bypass valve allows for maintenance of the solenoid valves without having to shut down the process valve. The use of the Maintenance Bypass Valve is not required for functional testing of the RCS unit. The RCS is available as a base unit (5R) and base unit with on-board PLC (5L). The 5L unit with on-board PLC is programmed with the logic required for proper operation. The type of operation (2oo2 NC, 2oo2 NO, 2oo2 DA, 1oo1HS NC, 1oo1HS NO) must be specified by the customer at the time of order. During normal operation of a 5L construction power is routed through the PLC to SOV1 and SOV2. Pressure switches (PS1, PS2 and PS3) are monitored by the PLC. In the event of a PLC failure, SOV1 and SOV2 will be connected directly to the Diagnostic Control System (hereafter referred to as DCS) output, allowing the DCS to have supervisory control of SOV1 and SOV2. Normal operation of the processed valve unit will not be effected during this event. The RCS unit will continue to function with restricted capabilities.

### Under normal operating conditions:

The RCS allows for periodic testing of the solenoids by cycling one solenoid valve and then the other either manually or automatically therefore attaining the desired safety availability. This testing is performed online without the need for bypassing of the safety action and without interruption of the process.

For all constructions, three pressure switches are included to provide indication of each solenoid-operated valve and bypass valve position.

**Normally Closed Construction:** the RCS supplies air to the process valve actuator through the "Process" port when energized.

**Normally Open Construction:** the RCS blocks the incoming pneumatic signal and connects the "Process" port to the "Exhaust" port when energized.

**Double Acting Construction:** the incoming pneumatic control signal passes through the RCS to one side (C2) of the process valve actuator while the other side (C1) of the process valve actuator is vented through the RCS when energized. **The 1oo1 HS mode cannot be used with the double acting construction.**

### When a trip occurs:

**Normally Closed Construction:** the RCS blocks the incoming pneumatic signal and connects the "Process" port to the "Exhaust" port. This vents the air signal from the process valve actuator and allows the actuator return spring to move the process to its fail-safe position.

**Normally Open Construction:** the RCS supplies air to the process valve actuator through the "Process" port. This allows the actuator to move the process to its fail-safe position.

**Double Acting Construction:** (C2) of the process valve actuator is vented through the RCS while the pneumatic control signal is applied to (C1) of the process valve actuator. This causes the process valve actuator to move from its normal operating position to its fail-safe position.

## HARDWARE

For proper operation, a pneumatic pressure of 3-150 PSI must be supplied to the RCS [process connection] while a pressure of 40-150 PSI must be supplied to the [pilot connection]. It is housed in a 20" x 16" x 8" enclosure. The primary components include:

- Hard anodized aluminum manifold body
- Two low power solenoid-operated ISO-3 valves
- A key-actuated bypass valve.
- Three pressure switches (ATEX rated Ex d IIC).
- An electrical terminal block for wiring termination (ATEX rated Ex e IIC)
- Associated wiring.
- An on-board digital processor (RCS-L only)

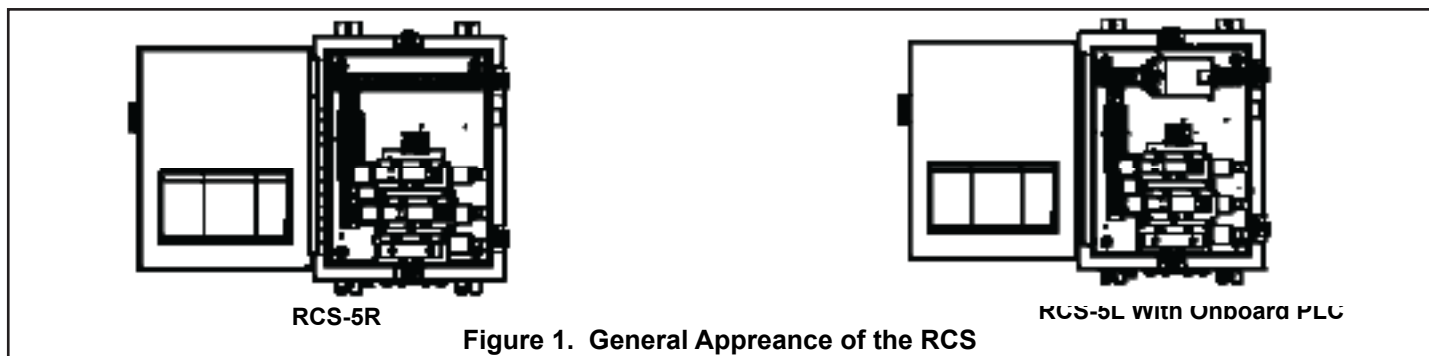

Figure 1. General Appearance of the RCS

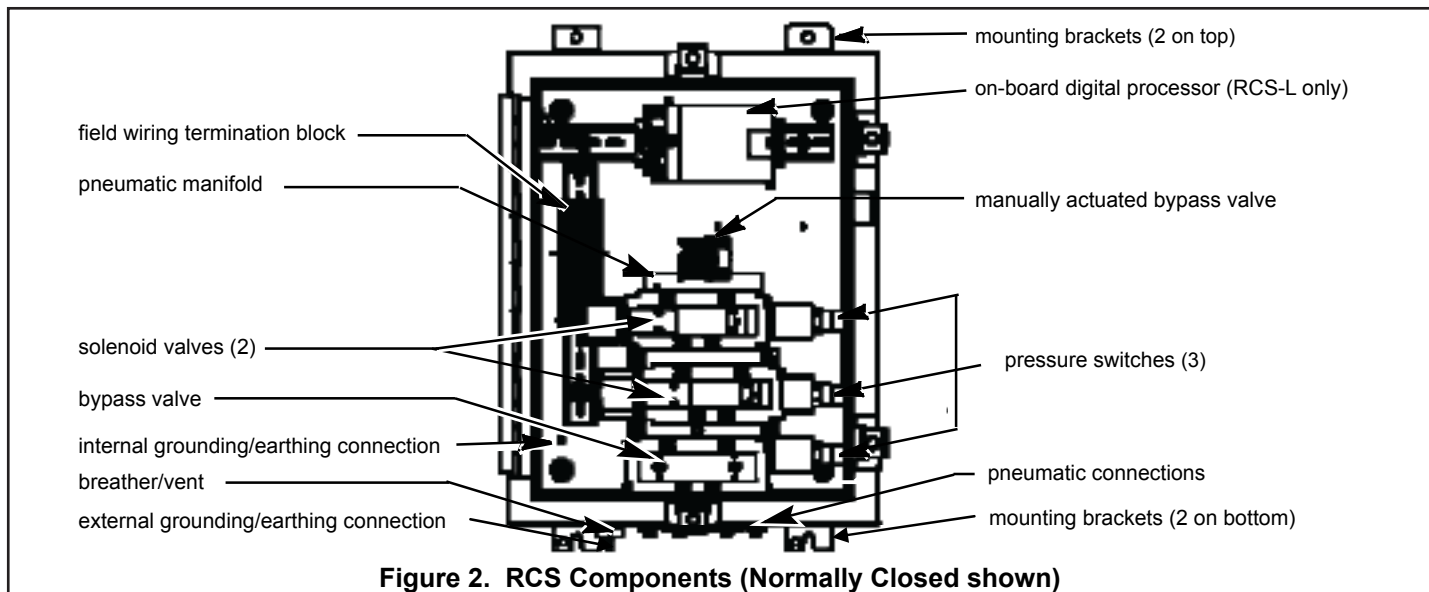



Figure 2. RCS Components (Normally Closed shown)

## ATEX ENVIRONMENTAL RATINGS

CE 0344  II 2G

Ex db eb mb IIC T\* Gb

- Ex : Explosion Protection Marking
- II: Equipment Group Other than Mines
- 2G: Category 2; Gas Atmosphere
- Ex : Explosion Protected
- db : Flameproof Protection Method

- eb : Increased Safety Protection Method
- mb : Encapsulation safety method (solenoid only)
- IIC : Atmosphere Group: Acetylene & Hydrogen
- \*T180°C : Temperature Class 180°C-120/60-110/50 or 230/50-240/50 Applications
- \*T6 : Temperature Class 85°C-12/DC, 24/DC, 48/DC or 120/DC Applications
- Gb : Equipment Protection level ("High" Level)

## GENERAL SPECIFICATIONS

### Solenoid Operator:

12, 24, 48 or 120 Volt DC Low Power, Class F coil-1.4 watts and 1.7 watts (1.7 watts does not apply to ATEX versions)  
120/60-110/50 or 230/50-240/50 AC  
10.1 Watts

### Pneumatic Valve:

ISO-3; 5/2 air-spring valve; solenoid operated/Requires external pilot air supply.

### Bypass Valve:

ISO-3; 5/2 air-spring valve; manually operated/Requires external pilot air supply.

### Manifold:

3- station ISO base; unique pneumatic circuit design

### Pressure Switches:

3 each (ATEX rated Ex II 2G D Ex IIC T6)

### Pressure Switch Type:

SPDT switches, hermetically sealed, Anodized Aluminum

### Switch Contact Rating:

Gold contacts (std) 1 amp suppressed resistive load; .5 amps inductive load @ 28 VDC.  
Silver contacts (opt) 5 amps suppressed resistive load; 3 amps inductive load @ 28 VDC.

### Connection & Setting:

1/4" NPTF; 3 psi increasing/ 1 psi decreasing; non-adjustable.

### Electrical:

#### Digital Processor (PLC):

RCS-L only, 14 inputs, 10 outputs

### Pneumatic Connections:

#### Pilot:

1/8" NPTF

#### Pilot Pressure:

40-150 psi

#### Inlet & Process:

1/2" NPTF

#### Exhaust Port:

1/2" NPTF

#### Process Pressure Range:

3 psi to 150 psi

#### Air Quality:

Instrument air per ANSI/ISA 7.0.01-1996  
Particle size ≤ 40 microns.

### Materials:

#### Enclosure:

Stainless Steel (304 SS, 316SS) or Fiberglass (Fiberglass does not apply to ATEX versions)

Size:  
24"x 16"x 8"

Weight:  
Approximately 75 lbs.

Mounting Panel  
Painted Steel

Manifold:  
Anodized aluminum.

Valves:  
Body – Die-cast Aluminum alloy, Sealing-  
Nitrile (NBR) and Polyurethane (PUR),  
Spool and Stainless Steel.

Solenoid Coil:  
Epoxy encapsulated.

Pressure Switches:  
316 Stainless Steel Wetted Surfaces

**Environmental:**  
Ambient temperature range:  
Consult panel nameplate to verify.  
• RCS-R = -40°F to 140°F (-40°C to 60°C)  
• RCS-R with local manual reset option  
= -4°F to 140°F (-20°C to 60°C)  
• RCS-L = -4°F to 131°F (-20°C to 55°C)

**Approvals:**  
Exida  
Certified SIL 3 capable (Standard  
Normally Open and Normally Closed  
constructions, see SIL certificate for  
special constructions).

## NAMEPLATE INFORMATION (ATEX VERSIONS ONLY)

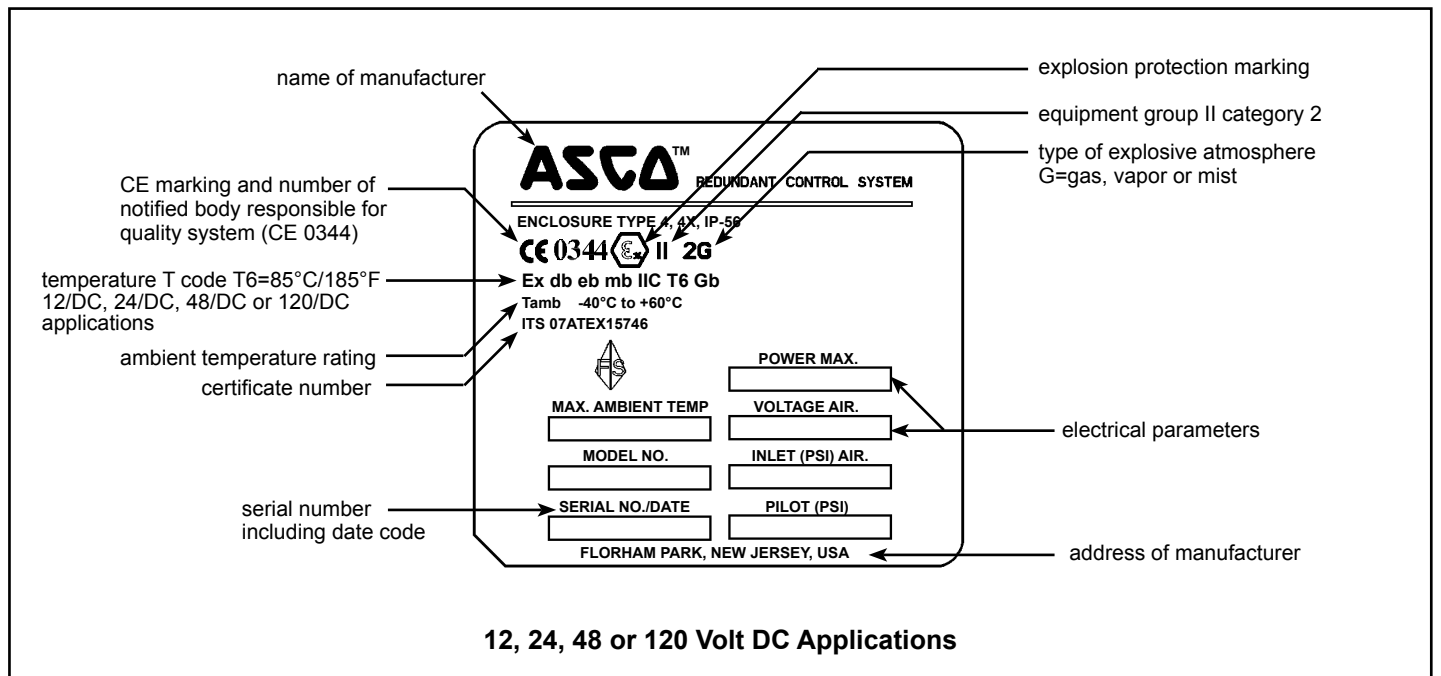
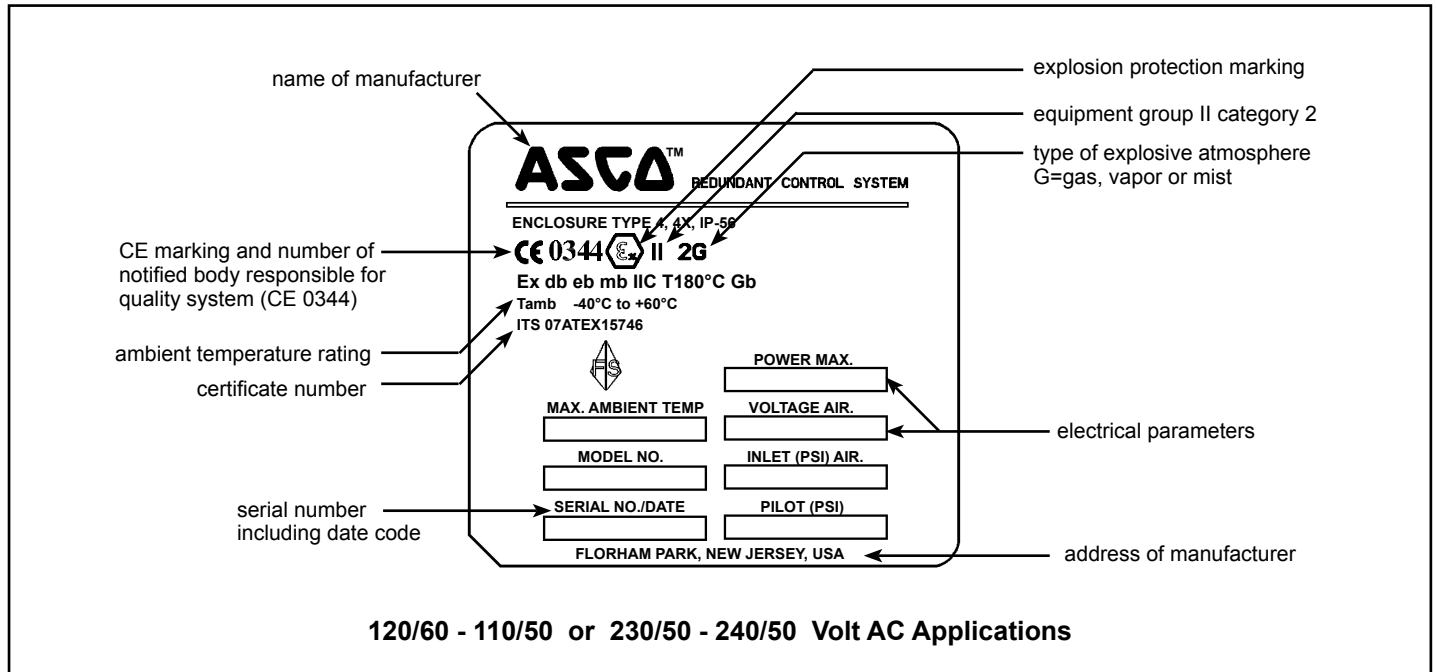

# INSTALLATION

This section provides the information needed to install the RCS.

## Unpacking:

Upon receipt of the RCS, unpack it carefully and visually check for damage. The packing list shows the complete model number and describes the features of the unit.

1. If the unit is damaged, immediately contact ASCO.
2. If everything is in order, proceed to the instructions in the following sections.

## Mounting Location Considerations:

The RCS is designed to be field mounted near the process valve to be actuated. The following factors should be considered when selecting a mounting location:

- **Accessibility:** Allow ample space for door operation, and for wiring and tubing runs.
- **Temperature:** Consider the amount of heat generated by equipment in the mounting area. The RCS is intended for operation in ambient temperatures from -40°C to 60°C (RCS-R), -20°C to 60°C (RCS-R with local manual reset option), from -20°C to 55°C (RCS-L).

**▲ WARNING: Explosion Hazard! Do not remove or replace any component while circuit is live unless the area is known to be nonhazardous.**

ASCO components are intended to be used only within the technical characteristics as specified on the nameplate. Changes to the equipment are only allowed after consulting the manufacturer or its representative. The Redundant Control System with ATEX certification is intended for installation in potentially explosive atmospheres, ATEX category 2G, gas Group IIC. The surface temperature classification depends on the voltage, wattage and ambient temperature which are stated on the nameplate. Depending on the ambient/operation temperature heat resistant cabling capable for the temperature as indicated on the nameplate must be used.

## Mounting:

The RCS is designed to be mounted using the four mounting brackets provided on the enclosure corners as shown in the figure below. It is recommended that four 3/8" or 10 mm diameter bolts be used.

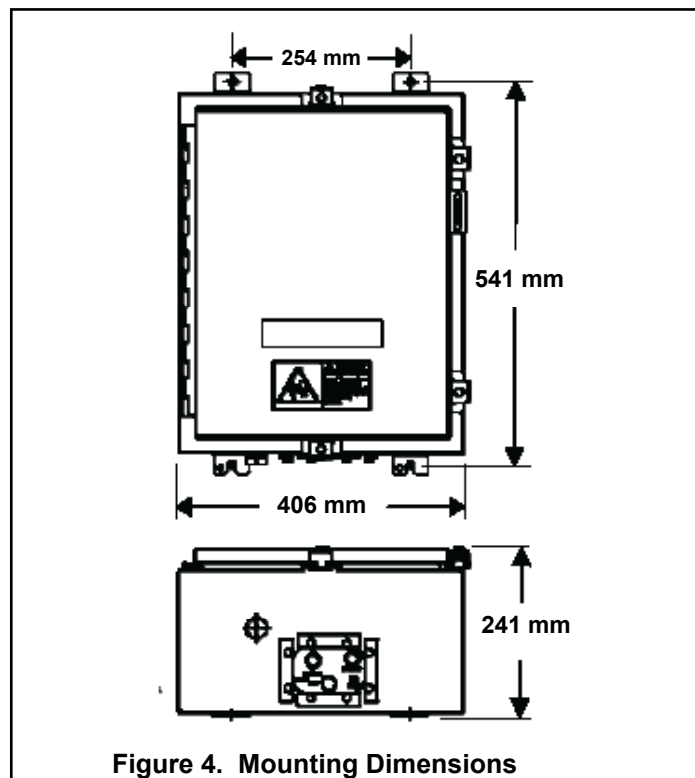

## Field Connections:

Pneumatic Connections (Figure 5 A)

**▲ WARNING: Explosion Hazard! Do not remove or replace any component while circuit is live unless the area is known to be nonhazardous.**

The RCS should be mounted as closely to the process valve as possible. In order to insure proper operation of the process valve, tubing runs should be as straight and short as possible. Recommended piping for the inlet and outlet pneumatic connections to the RCS is 1/2" stainless steel tubing. Recommended piping for pilot supply is 1/8" stainless steel tubing.

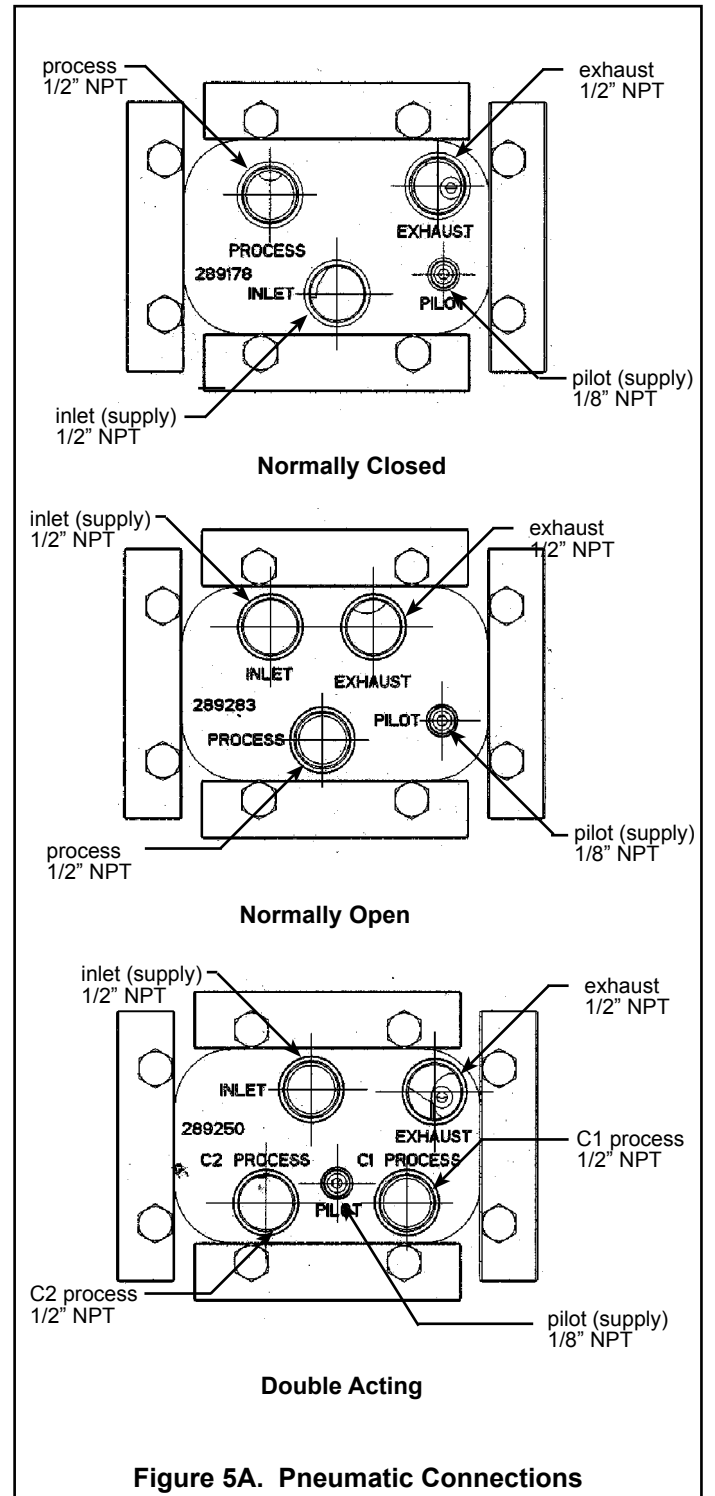

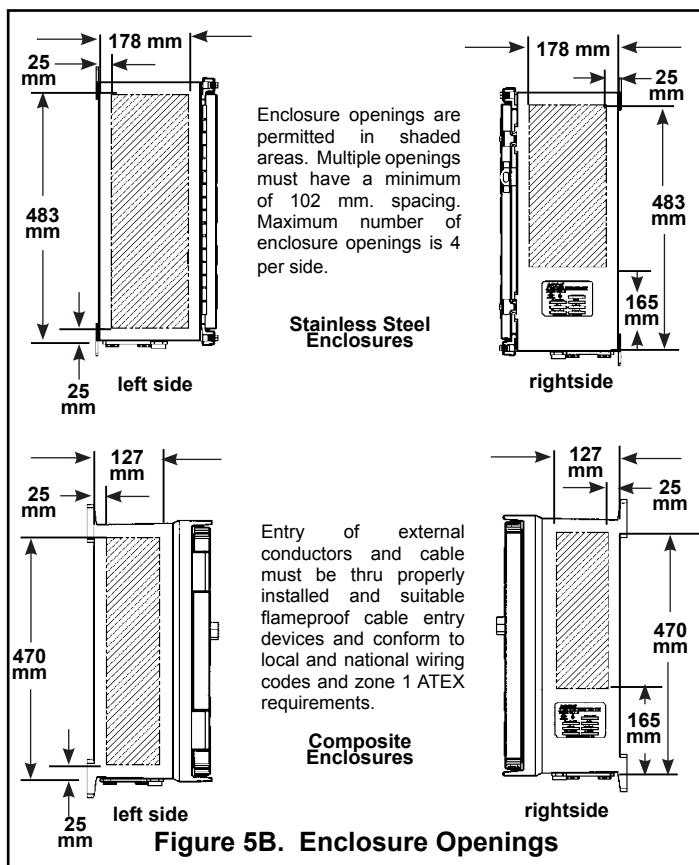

Figure 5B. Enclosure Openings

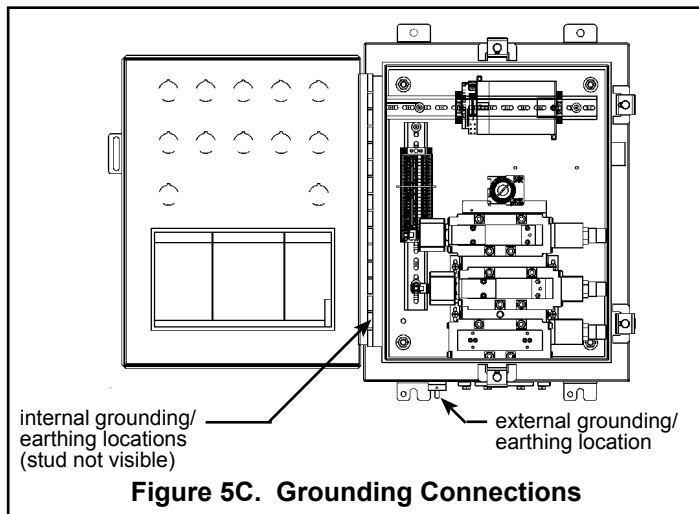

Figure 5C. Grounding Connections

## Wiring Guidelines

The following general guidelines apply to all wiring discussed in this document.

**▲WARNING: Circuit power must be removed from the device prior to disconnecting the wiring on either the field or internal side of the terminal strip.**

- Wiring shall be according to the National Electrical Code (ANSI-NFPA 70), Zone 1 ATEX requirements or other applicable codes.
- Wire size: stranded 16 and 18 AWG.
- The terminal clamps are designed for one wire only; DO NOT attempt to terminate multiple wires into one terminal.
- Use care when running signal wiring near to or crossing conduit or wiring that supplies power to motors, solenoids, lighting, horns, bells, etc.
- AC power wiring should be run in a separate conduit from DC power. All power wiring to and from the RCS should be in grounded conduit.

- The RCS should be connected to a high quality instrument grade ground with #14 AWG or heavier wire. A grounding stud is provided both inside and outside the enclosure.

## Electrical Connection (Customer Responsibility):

### General (Figure 5 B)

1. In all cases follow local and national electrical codes and confirm compliance with Zone 1 ATEX requirements.
2. Placement of the conduit connection is up to the customer, in compliance with Zone 1, ATEX requirements, based on location and ease of installation. The upper or lower left side of the box will give the shortest run to the wire terminal.
3. Cable/conduit connections can be added in location as shown on Figure 5 B. Entry of external conductors and cables must be through properly installed and suitable certified flameproof cable entry devices and in accordance with ATEX Zone 1 increased safety requirements. Assemble and install cable glands per manufacturer's instructions. Connect cable ground connections to the grounding/earthing terminal blocks or grounding / earth studs provided internally and externally.
4. It is recommended that standard industry practices are followed to prevent condensation from entering the enclosure and, in some cases of Class I, Div 2 or ATEX Zone 1 conditions, to prevent hazardous gasses and vapors from migrating through the conduit to the control room or open ignition source.

### Grounding and Earthing (Figure 5 C)

Internal and external grounding studs are provided on the RCS product. Ground/earth the product in accordance with local and national electric codes as well as ATEX Zone 1 requirements. Green earthing terminal blocks are provided for easy installation of conductor up to 4 mm sq.

Only insert one conductor per terminal block. Grounding studs are provided inside and outside of the enclosure for additional grounding/earthing requirements. (see Figure 5 C)

### RCS-R Base Unit (without on-board PLC)

1. Connect the power source to the designated terminals (SOV1, SOV2) as per wiring diagram provided with the RCS unit. Wiring diagrams are available on the Internet at: [www.ascovalve.com/rcsconfigurator](http://www.ascovalve.com/rcsconfigurator)
2. Wire the three pressure switches (PS1, PS2 & PS3) as per wiring diagram.
3. Wire optional accessories.

### RCS-L Base Unit (with on-board PLC)

1. Connect to the PLC as per wiring diagram provided with the RCS unit. Wiring diagrams are available on the Internet at: [www.ascovalve.com/rcsconfigurator](http://www.ascovalve.com/rcsconfigurator) (SOV1, SOV2, PS1, PS2 and PS3 are pre-wired to PLC by ASCO)
2. Use care when running signal wiring near to or crossing conduit or wiring that supplies power to motors, solenoids, lighting, horns, bells, etc.
3. AC power wiring should be run in a separate conduit from DC power. All power wiring to and from the RCS should be in grounded conduit.
4. The RCS should be connected to a high quality instrument grade ground with #14 AWG or heavier wire. A grounding stud is provided both inside and outside the enclosure.
5. Torque wire connection screw on PLC to 0.56Nm (5 inch-pound).

## Section 1. - Normally Closed

### 1. General Operation

The RCS is a two-out-of-two (2oo2) or one-out-of-one hot standby (1oo1 HS) voting, solenoid-operated valve system designed for use as a component in safety instrumented systems. It functions as a redundant pneumatic tripping device to control the pilot air signal to a process valve actuator. Both solenoids must be de-energized (De-Energize-To-Trip Version) or energized (Energize-To-Trip Version) prior to moving the process to its fail-safe position. Three pressure switches are included to provide indication of each solenoid-operated valve and bypass valve position.

The RCS allows for periodic testing of the solenoids by cycling one

solenoid valve and then the other either manually (when ordered with a local initiation of SOV test option) or automatically (by the system DCS or the onboard diagnostic processor) therefore maintaining the desired safety availability. This testing is performed online without the need for bypassing of the safety action and without interruption of the system process.

Under normal operating conditions, the RCS supplies pilot air to the process valve actuator through the “process” port. When a trip occurs, the RCS blocks the incoming pneumatic signal and connects the “process” port to the “exhaust” port. This vents the air signal from the process valve actuator and allows the actuator return spring to move the process to its fail-safe position.

**The pressure switches report solenoid valve positions as follows:**

**RUN MODE:**

- De-Energize-To-Trip:(Figure3a)  
If solenoid valve #1 (resp. #2) is in the energized position, the contact of pressure switch #1 (resp. #2) is open. Pressure vents from pressure switch #1 (resp #2). Pressure is applied to pressure switch #3 and contact closed.
- Energize-To-Trip:(Figure 3b)  
If solenoid valve #1 (resp. #2) is in the de-energized position,

the contact of pressure switch #1 (resp. #2) is open. Pressure vents from pressure switch #1 (resp. #2). Pressure is applied to pressure switch #3 and contact closed.

**BYPASS MODE:**

- The manually operated maintenance bypass valve is used to isolate and depressurize the solenoid valves and pressure switches during maintenance. The maintenance bypass valve position is indicated by pressure switch #3.
- In the Bypass mode, the RCS “inlet” port is directly connected to the “process” port. The solenoid valves and pressure switches are vented to “exhaust”.
- In the Bypass mode, the contacts of pressure switches #1, #2 and #3 are open which indicates that no pressure is on the valves or pressure switches.

**Manually-Actuated maintenance bypass valve operation:**

The manually-actuated bypass valve has two positions: **NORMAL** for system run and **MAINTENANCE BYPASS** for maintenance of the solenoid valves and pressure switches. To change positions simply rotate the key (a lever option is available in place of the key) to the desired position indicated on the valve.

Pressure Switches:

The pressure switches are factory set to actuate at 3 psig -increasing and 1 psig decreasing pressure. The pressure switches are fixed and not adjustable.

Status of SOVs	Pressure Switches indicate as shown		
Solenoid Valves	Pressure Switch 1	Pressure Switch 2	Pressure Switch 3
Both SOVs Energized	O	O	CL
Both SOVs De-Energized	CL	CL	CL
SOV 1 De-Energized Only	CL	O	CL
SOV 2 De-Energized Only	O	CL	CL
<b>Bypass Mode</b>	<b>O</b>	<b>O</b>	<b>O</b>

CL = Pressure switch Normally Open contact is Closed  
O = Pressure switch Normally Open contact is Open

**Figure 3a. Test Table of Solenoid Valve Status (Normally Closed, De-Energize-To-Trip)**

Status of SOVs	Pressure Switches indicate as shown		
Solenoid Valves	Pressure Switch 1	Pressure Switch 2	Pressure Switch 3
Both SOVs Energized	CL	CL	CL
Both SOVs De-Energized	O	O	CL
SOV 1 Energized Only	CL	O	CL
SOV 2 Energized Only	O	CL	CL
<b>Bypass Mode</b>	<b>O</b>	<b>O</b>	<b>O</b>

CL = Pressure switch Normally Open contact is Closed  
O = Pressure switch Normally Open contact is Open

**Figure 3b. Test Table of Solenoid Valve Status (Normally Closed, Energize-To-Trip)**

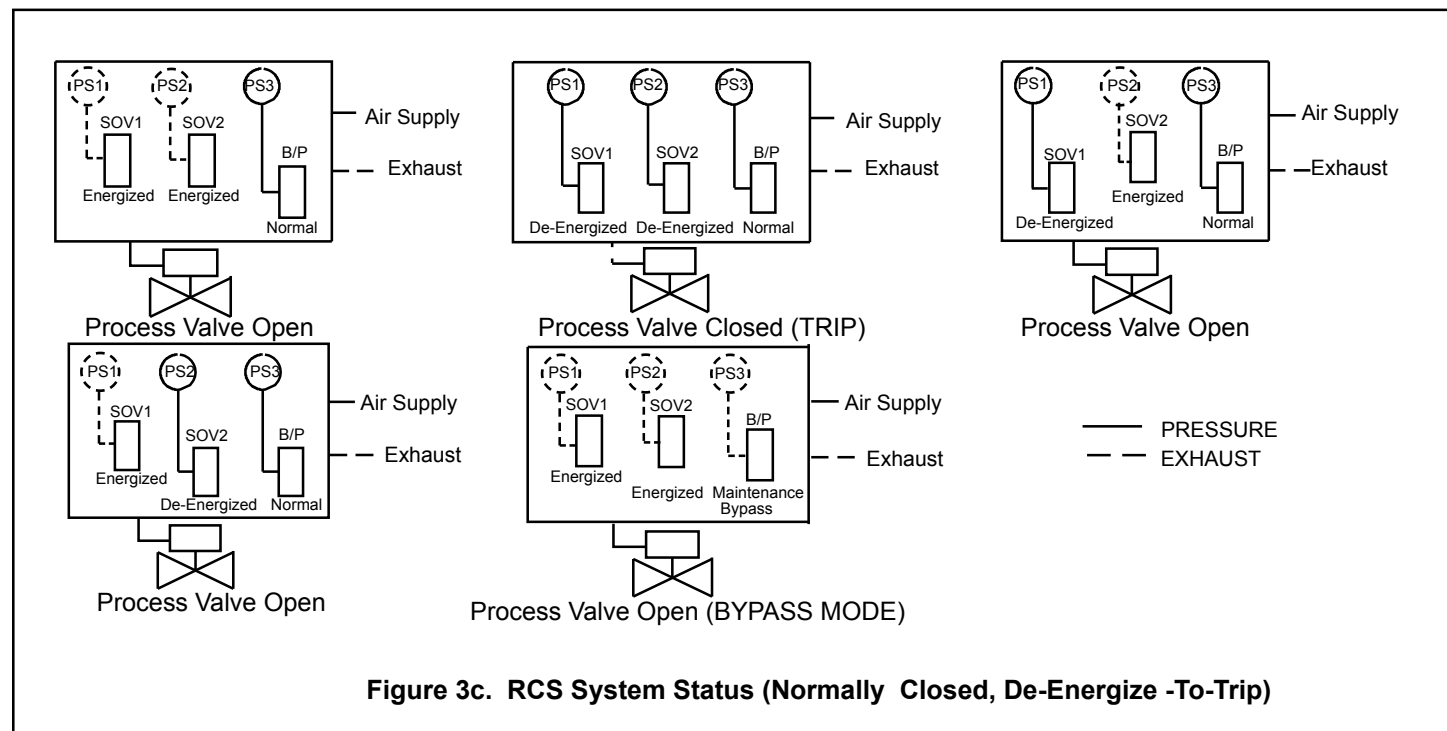

**Figure 3c. RCS System Status (Normally Closed, De-Energize -To-Trip)**



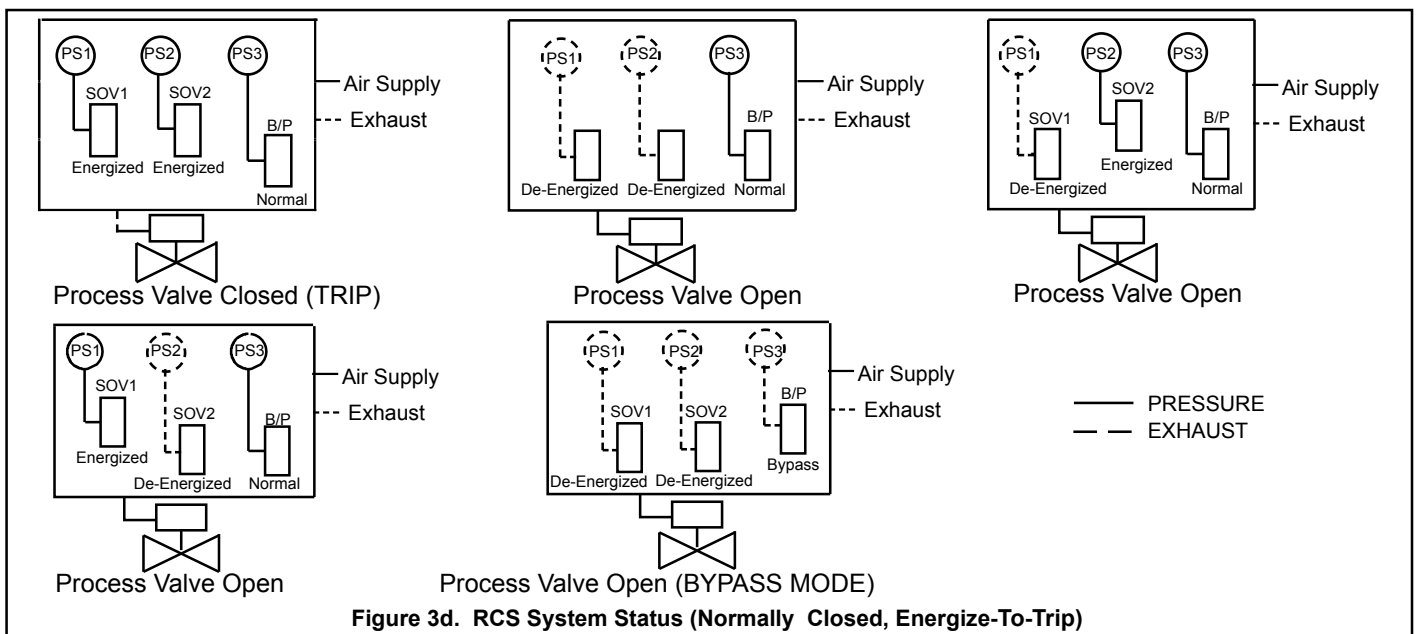

Figure 3d. RCS System Status (Normally Closed, Energize-To-Trip)

## 2. Testing and Maintenance:

### Testing:

#### Solenoid-operated valve testing

The solenoid-operated valves and their associated pressure switches can be tested online without interruption of the process. This testing is implemented by cycling each solenoid-operated valve and comparing the associated pressure switch contact reading to the test table (see Figure 3a and 3b).

#### Partial Stroke testing

A partial stroke of the process valve can be performed online without interruption of the process. This testing is implemented by performing solenoid-operated valve testing, then moving the process valve toward the safe state for a predetermined time. At the end of the predetermined time, the process valve is returned to the normal position.

Testing can be automated using a programmable logic controller (PLC), a distributed control system (DCS) or an on-board digital processor (RCS-L only).

**CAUTION: (De - Energize - To - Trip Version) De-energizing two solenoid valves at the same time will initiate a shutdown.**

**(Energize - To - Trip Version) Energizing two solenoid valves at the same time will initiate a shutdown.**

1. At all times during testing, one out of the two solenoid-operated valves must be in the energized position (De-Energize-To-Trip Version) or de-energized (Energize-To-Trip Version).
2. IF, during the test process, the pressure switches do not indicate what is expected according to the test table (see Figure 3a and 3b), the second solenoid-operated valve must not be de-energized (De-Energize-To-Trip Version) or energized (Energize-To-Trip Version).

### Maintenance:

**WARNING: Potential Electrostatic Charging Hazard. Use wet or damp cloth when cleaning any non-metallic/painted surfaces.**

The Pneumatic RCS requires no routine maintenance except periodic inspections for loose wires and fittings. The enclosure should be opened occasionally and the components checked to make sure they are tight, clean, and dry. The Breathe/Vent valve shall be inspected for obstruction and that it is free of debris during routine maintenance cycles and during manual proof testing.

#### Manually-Actuated Bypass Valve

If it is necessary to replace a solenoid-operated valve or pressure

switch during normal operation, the manually-operated bypass valve is used.

This valve is used to isolate and depressurize the solenoid valves and pressure switches for maintenance only.

When the switch is rotated to the bypass position, the RCS manifold channels the inlet pressure directly to the process port. Pressure to the solenoid valves and pressure switches are vented to "exhaust". Contacts to pressure switches #1, #2, and #3 are open which signals the PLC/DCS that the RCS is in bypass and not in shut down.

#### Manual Bypass Valve Operation (for maintenance only)

**WARNING: Explosion Hazard. Do not open the enclosure unless area is known to be non-hazardous.**

1. Turn the key clockwise from "Normal" to "Maintenance Bypass". The system pressure is now bypassed directly from "inlet" to "process" so that the process valve position is maintained.
2. Verify that all 3 pressure switch contacts are open, indicating the RCS is in Bypass.

**WARNING: Remove the maintenance bypass key from the switch and place the key in the bottom of the enclosure until maintenance has been completed.**

**WARNING: Explosion Hazard. Do not remove or replace any component while circuit is live unless area is known to be non-hazardous.**

3. Turn off power to the RCS; disconnect appropriate wires from terminal block.
4. Remove device (coil, solenoid valve, or pressure switch) and install the new device following instructions supplied. If replacing a solenoid valve, apply a small amount of anti-seize to the bolt threads and torque to 160-175 in-lbs in a crisscross pattern. Reconnect wires to appropriate terminal, (see wiring diagrams).
5. Turn on power to the RCS. Verify that each device has power and is in the correct state. (see Figure 3a and 3b).
6. Replace key in the Maintenance Bypass and rotate counter-clockwise to the "Normal" position.
7. Have the control room run through the programmed test to be sure the system is operating properly.

## Section 2. - Normally Open

### 1. General Operation

The RCS is a two-out-of-two (2oo2) or one-out-of-one hot standby (1oo1 HS) voting, solenoid-operated valve system designed for use as a component in safety instrumented systems. It functions as a redundant pneumatic tripping device to control the air signal to a process valve actuator. Both solenoids must be de-energized (De-Energize-To-Trip) or energized (Energize-To-Trip) prior to moving the process to its fail-safe position.

Three pressure switches are included to provide indication of each solenoid-operated valve and bypass valve position. The RCS allows for periodic testing of the solenoids by cycling one solenoid valve and then the other either manually (when ordered with a local initiation of SOV test option) or automatically (by the system DCS or the onboard diagnostic processor in the case of a 5L unit) therefore attaining the desired safety availability. This testing is performed online without the need for bypassing of the safety action and without interruption of the system process.

Under normal operating conditions, the RCS blocks the pilot air supply from the process valve and connects the "process" port to the "exhaust" port. When a trip occurs, the RCS supplies pilot air to the process valve actuator through the "process" port. This allows the actuator to move the process valve actuator to its fail-safe position.

#### Pressure Switches:

The pressure switches are factory set to actuate at 3 psig-increasing and 1 psig decreasing pressure. The pressure switches are fixed and not adjustable.

Status of SOVs	Pressure Switches indicate as shown		
Solenoid Valves	Pressure Switch 1	Pressure Switch 2	Pressure Switch 3
Both SOVs Energized	CL	CL	CL
Both SOVs De-Energized	O	O	CL
SOV 1 De-Energized Only	O	CL	CL
SOV 2 De-Energized Only	CL	O	CL
<b>Bypass Mode</b>	<b>O</b>	<b>O</b>	<b>O</b>

CL = Pressure switch Normally Open contact is Closed  
O = Pressure switch Normally Open contact is Open

**Figure 6a. Test Table of Solenoid Valve Status (Normally Open, De-Energize-To-Trip)**

The pressure switches report solenoid valve positions as follows:  
**RUN MODE:**

- De-Energize-To-Trip: (Figure 6a & 6c)  
If solenoid valve #1 (resp. #2) is in the energized position, the contact of pressure switch #1 (resp. #2) is closed. Pressure is applied to pressure switch #1 (resp. #2). Pressure is applied to pressure switch #3 and contact closed.
- Energize-To-Trip: (Figure 6b & 6d)  
If solenoid valve #1 (resp. #2) is in the de-energized position, the contact of pressure switch #1 (resp. #2) is closed. Pressure is applied to pressure switch #1 (resp. #2). Pressure is applied to pressure switch #3 and contact closed.

#### BYPASS MODE:

- The manually operated bypass valve is used to isolate and depressurize the solenoid valves and pressure switches during maintenance. The maintenance bypass valve position is indicated by pressure switch #3.
- In the Bypass mode the "inlet" air to the RCS is blocked, the "process" port is connected to the "exhaust". In addition, the solenoid valves and pressure switches, including pressure switch #3, are vented to "exhaust".
- In the Bypass mode, the contacts of pressure switches #1, #2 and #3 are open which indicates that no pressure is on the valves or pressure switches.

#### Manually-Actuated Bypass Valve Operation:

The manually-actuated bypass valve has two positions: **NORMAL** for system run and **MAINTENANCE BYPASS** for maintenance of the solenoid valves and pressure switches. To change positions simply rotate the key (a lever option is available in place of the key) to the desired position indicated on the valve.

Status of SOVs	Pressure Switches indicate as shown		
Solenoid Valves	Pressure Switch 1	Pressure Switch 2	Pressure Switch 3
Both SOVs Energized	O	O	CL
Both SOVs De-Energized	CL	CL	CL
SOV 1 Energized Only	O	CL	CL
SOV 2 Energized Only	CL	O	CL
<b>Bypass Mode</b>	<b>O</b>	<b>O</b>	<b>O</b>

CL = Pressure switch Normally Open contact is Closed  
O = Pressure switch Normally Open contact is Open

**Figure 6b. Test Table of Solenoid Valve Status (Normally Open, Energize-To-Trip)**

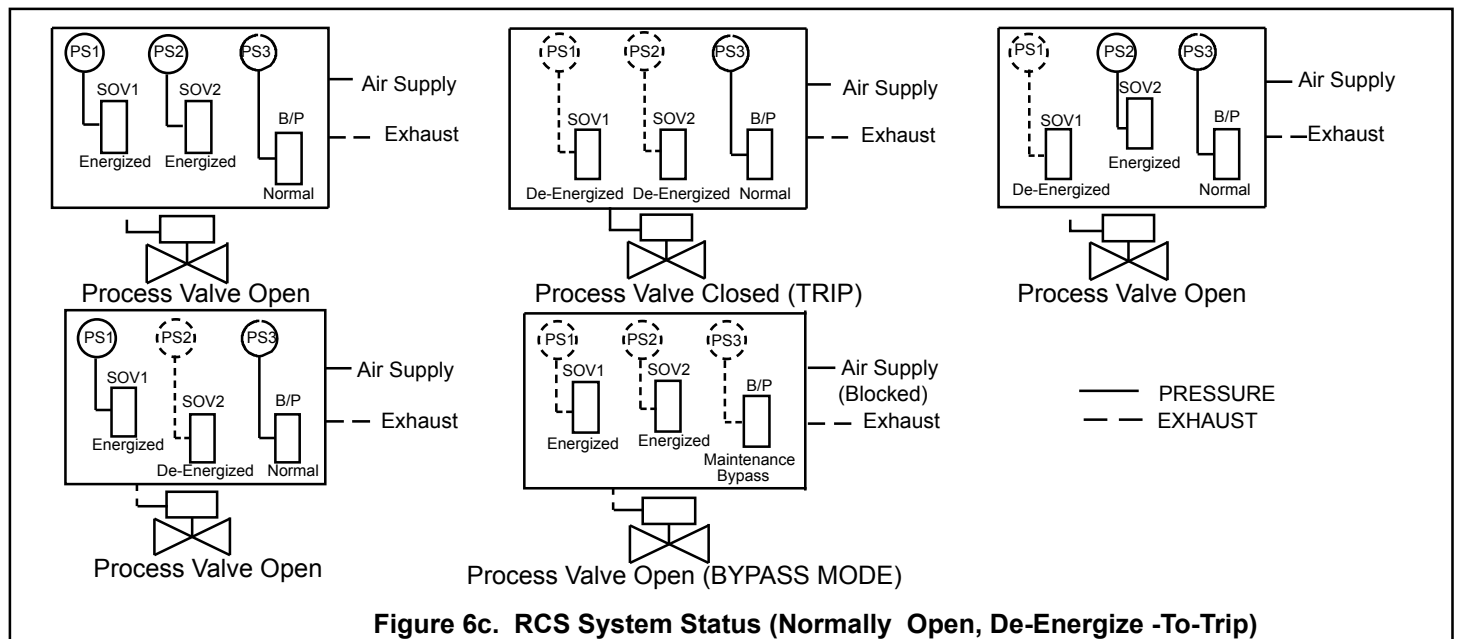

**Figure 6c. RCS System Status (Normally Open, De-Energize-To-Trip)**

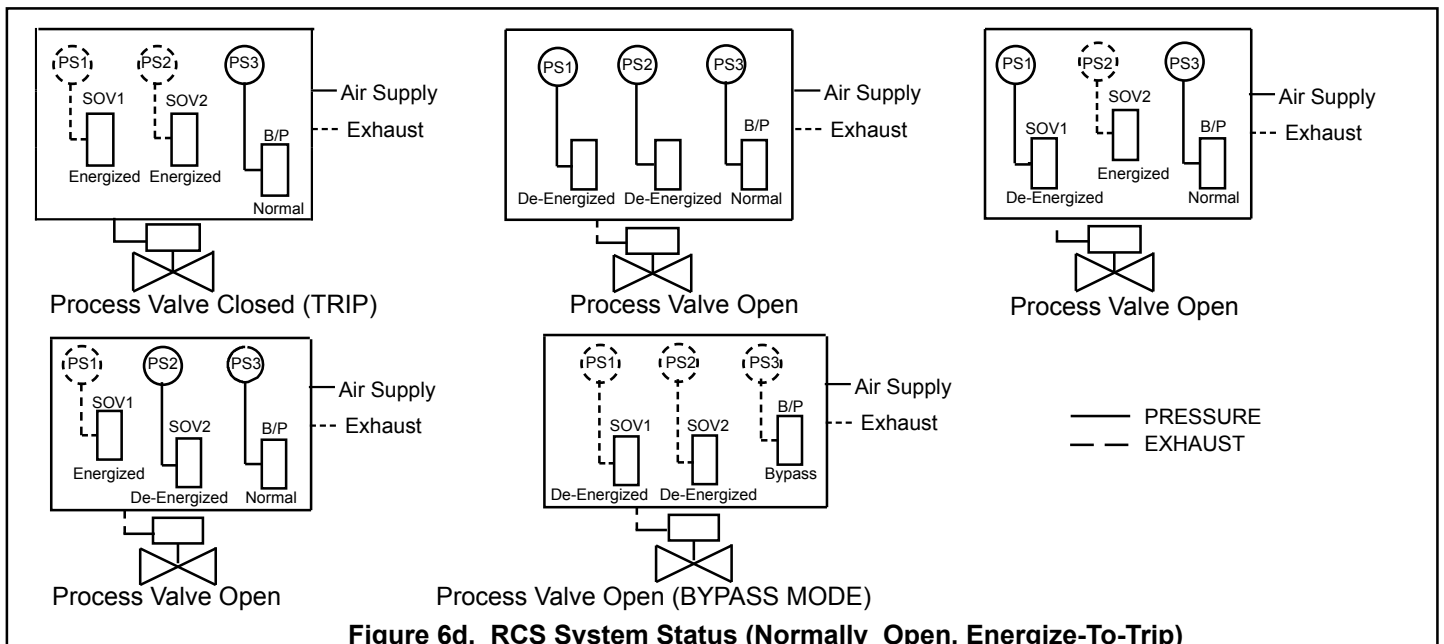

Figure 6d. RCS System Status (Normally Open, Energize-To-Trip)

## 2. Testing and Maintenance:

### Testing:

#### Solenoid-operated valve testing

The solenoid-operated valves and their associated pressure switches can be tested online without interruption of the process. This testing is implemented by cycling each solenoid-operated valve and comparing the associated pressure switch contact to the test table (see Figure 6a and 6b).

#### Partial Stroke testing

A partial stroke of the process valve can be performed online without interruption of the process. This testing is implemented by performing a solenoid-operated valve testing, then moving the process valve toward the safe state for a predetermined time. At the end of the predetermined time, the process valve is returned to the normal position. Testing can be automated using a programmable logic controller (PLC), a distributed control system (DCS) or an on-board digital processor (RCS-L only).

**CAUTION: (De - Energize - To - Trip Version) De - energizing two solenoid valves at the same time will initiate a shutdown.**

**(Energize - To - Trip Version) Energizing two solenoid valves at the same time will initiate a shutdown.**

1. At all times during testing, one out of the two solenoid-operated valves must be in the energized position (De-Energize-To-Trip Version) or de-energized (Energize-To-Trip Version).
2. IF, during the test process, the pressure switches do not indicate what is expected according to the test table (see Figure 6a and 6b), a second solenoid-operated valve must not be de-energized (De-Energize-To-Trip Version) or energized (Energize-To-Trip Version).

### Maintenance:

**WARNING: Potential Electrostatic Charging Hazard. Use wet or damp cloth when cleaning any non-metallic/painted surfaces.**

The Pneumatic RCS requires no routine maintenance except periodic inspections for loose wires and fittings. The enclosure should be opened occasionally and the components checked to make sure they are tight, clean, and dry.

#### Manually-Actuated Bypass Valve

If it is necessary to replace a solenoid-operated valve or pressure switch during normal operation, the manually operated bypass valve is used.

This valve is used to isolate and depressurize the solenoid valves and pressure switches for maintenance only.

When the switch is rotated to the bypass position, the “inlet” air to the RCS is blocked. The “process” port is connected to the “exhaust”. Pressure to the solenoid valves and pressure switches are vented to “exhaust”. Contacts to pressure switches #1, #2, and #3 are open which signals the PLC/DCS that the RCS is in bypass and not in shut down.

#### Manual Bypass Valve Operation (for maintenance only)

**WARNING: Explosion Hazard. Do not open the enclosure unless area is known to be non-hazardous.**

1. Turn the key clockwise from “Normal” to “Bypass”. The system pressure is now blocked by the RCS, “process” is connected to “exhaust”.
2. Verify that all 3 pressure switch contacts are open, indicating the RCS is in Bypass.

**WARNING: Remove the maintenance bypass key from the switch and place the key in the bottom of the enclosure until maintenance has been completed.**

**WARNING: Explosion Hazard. Do not remove or replace any component while circuit is live unless area is known to be non - hazardous.**

3. Turn off power to the RCS; disconnect appropriate wires from terminal block.
4. Remove device (coil, solenoid valve, or pressure switch) and install the new device following instructions supplied. If replacing a solenoid valve, apply a small amount of anti-seize to the bolt threads and torque to 160-175 in-lbs in a crisscross pattern. Reconnect wires to appropriate terminal (see wiring diagrams provided with unit). Wiring diagrams are available on the internet at: [www.ascovalve.com/rcsconfigurator](http://www.ascovalve.com/rcsconfigurator).
5. Turn on power to the RCS. Verify that each device has power and is in the correct state. (see Figure 6a and 6b).
6. Replace key in the Bypass and rotate counter-clockwise to the “Normal” position.
7. Have the control room run through the programmed test to be sure the system is operating properly.

### Section 3. - Double Acting

**NOTE: One-out-of-one hot standby (1oo1HS) mode cannot be used with the Double Acting RCS- L.**

#### 1. General Operation

The RCS is a two-out-of-two (2oo2) or one-out-of-one hot standby (1oo1 HS) voting, solenoid-operated valve system designed for use as a component in safety instrumented systems. Double acting RCS units are only available in 2oo2. It functions as a redundant pneumatic tripping device to control the air signal to a process valve actuator. Both solenoids must be de-energized (De-Energize-To-Trip) or energized (Energize-To-Trip) prior to moving the process to its fail-safe position.

Three pressure switches are included to provide indication of each solenoid-operated valve and bypass valve position. The RCS allows for periodic testing of the solenoids by cycling one solenoid valve and then the other either manually (when ordered with a local initiation of SOV test option) or automatically (by the system DCS or the onboard diagnostic processor in the case of the 5L unit) therefore attaining the desired safety availability. This testing is performed online without the need for bypassing of the safety action and without interruption of the system process.

Under normal operating conditions, the incoming pilot air supply for the process valve actuator passes through the RCS to one side (C2) of the process valve actuator while the other side (C1) of the process valve actuator is vented through the RCS.

When a trip occurs, (C2) of the process valve actuator is vented through the RCS while the pneumatic control signal is applied to (C1) of the process valve actuator. This forces the process

valve actuator to move from its normal operating position to its fail-safe position.

**The pressure switches report solenoid valve positions as follows:**

#### RUN MODE:

- **De-Energize-To-Trip:** (Figure9a&9c)  
If solenoid valve #1 (resp. #2) is in the energized position, the contact of pressure switch #1 (resp. #2) is open. Pressure vents from pressure switch #2. Pressure is applied to pressure switch #1 and #3.
- **Energize-To-Trip:** (Figure9b & 9d)  
If solenoid valve #1 (resp. #2) is in the de-energized position, the contact of pressure switch #1 (resp. #2) is open. Pressure vents from pressure switch #2. Pressure is applied to pressure switch #1 and #3.

#### BYPASS MODE:

- The manually operated maintenance bypass valve is used to isolate and depressurize the solenoid valves and pressure switches during maintenance. The maintenance bypass valve position is indicated by pressure switch #3.
- In the Bypass mode, the RCS “inlet” port is directly connected to the “process” port (C2), “process” port (C1) is directly connected to “exhaust”. In addition, the solenoid valves and pressure switches are vented to “exhaust”.
- In the Bypass mode, the contacts of pressure switches #2 and #3 are open, and #1 is closed, which indicates that no pressure is on the valves or pressure switches.

#### Manually-Actuated Bypass Valve Operation:

The manually-actuated bypass valve has two positions: **NORMAL** for system run and **MAINTENANCE BYPASS** for maintenance of the solenoid valves and pressure switches. To change positions simply rotate the key (a lever option is available in place of the key) to the desired position indicated on the valve.

#### Pressure Switches:

The pressure switches are factory set to actuate at 3 psig-increasing and 1 psig decreasing pressure. The pressure switches are fixed and not adjustable.

Status of SOVs	Pressure Switches indicate as shown		
Solenoid Valves	Pressure Switch 1	Pressure Switch 2	Pressure Switch 3
Both SOVs Energized	O	O	CL
Both SOVs De-Energized	CL	CL	CL
SOV 1 De-Energized Only	CL	O	CL
SOV 2 De-Energized Only	O	CL	CL
<b>Bypass Mode</b>	<b>CL</b>	<b>O</b>	<b>O</b>

CL = Pressure switch contact is Closed  
O = Pressure switch contact is Open

**Figure 9a. Test Table of Solenoid Valve Status (Double Acting, De-Energize-To-Trip)**

Status of SOVs	Pressure Switches indicate as shown		
Solenoid Valves	Pressure Switch 1	Pressure Switch 2	Pressure Switch 3
Both SOVs Energized	CL	CL	CL
Both SOVs De-Energized	O	O	CL
SOV 1 Energized Only	CL	O	CL
SOV 2 Energized Only	O	CL	CL
<b>Bypass Mode</b>	<b>CL</b>	<b>O</b>	<b>O</b>

CL = Pressure switch contact is Closed  
O = Pressure switch contact is Open

**Figure 9b. Test Table of Solenoid Valve Status (Double Acting, Energize-To-Trip)**

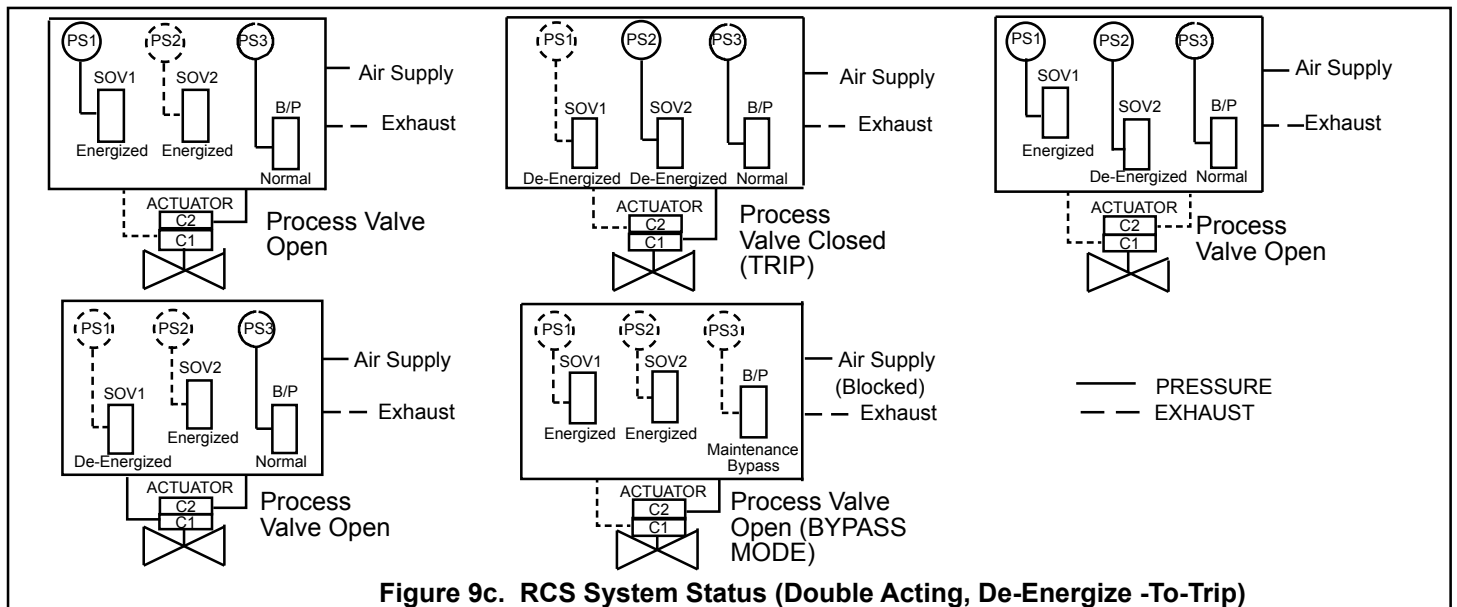

**Figure 9c. RCS System Status (Double Acting, De-Energize -To-Trip)**

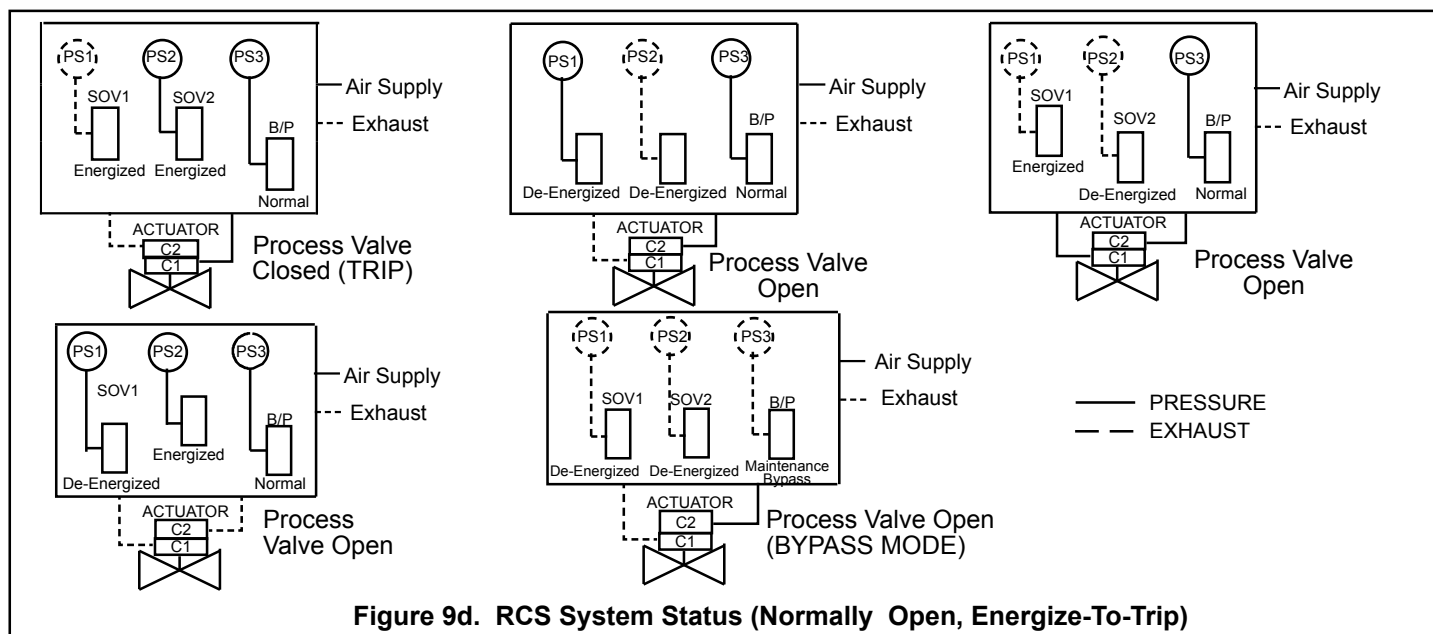

Figure 9d. RCS System Status (Normally Open, Energize-To-Trip)

## 2. Testing and Maintenance:

### Testing:

#### Solenoid-operated valve testing

The solenoid-operated valves and their associated pressure switches can be tested online without interruption to the process. This testing is implemented by cycling each solenoid-operated valve and comparing the associated pressure switch contact to the test table (see Figure 9a and 9b).

#### Partial Stroke testing

A partial stroke of the process valve can be performed online without interruption to the process. This testing is implemented by performing a solenoid-operated valve testing, then moving the process valve toward the safe state for a predetermined time. At the end of the predetermined time, the process valve is returned to the normal position. Testing can be automated using a programmable logic controller (PLC), a distributed control system (DCS) or an on-board digital processor (RCS - L only).

**⚠ CAUTION: (De - Energize - To - Trip Version) De - energizing two solenoid valves at the same time will initiate a shutdown.**

**(Energize - To - Trip Version) Energizing two solenoid valves at the same time will initiate a shutdown.**

1. At all times during testing, one out of the two solenoid-operated valves must be in the energized position (De-Energize-To-Trip Version) or de-energized (Energize-To-Trip Version).
2. IF, during the test process, the pressure switches do not indicate what is expected according to the test table (see Figure 9a and 9b), a second solenoid-operated valve must not be de-energized (DE-Energize-To-Trip Version) or energized (Energize-To-Trip Version).

### Maintenance:

**⚠ WARNING: Potential Electrostatic Charging Hazard. Use wet or damp cloth when cleaning any non-metallic/painted surfaces.**

The Pneumatic RCS requires no routine maintenance except periodic inspections for loose wires and fittings. The enclosure should be opened occasionally and the components checked to make sure they are tight, clean, and dry.

#### Manually-Actuated Bypass Valve

If it is necessary to replace a solenoid valve or pressure switch during normal operation, the manually operated bypass is used. The valve

is used to isolate and depressurize the solenoid valves and pressure switches for maintenance only.

When the maintenance bypass valve is in its maintenance bypass position, the RCS “inlet” port is directly connected to the “process” port (C2) allowing the process to continue. In addition, the solenoid valves and pressure switches, including (C1) and pressure switch #3, are vented to “exhaust”. In the Maintenance Bypass Mode, the contacts of pressure switches #2 and #3 are open, and #1 is closed, which indicates that no pressure is on the valves or pressure switches.

#### Manual Bypass Valve Operation

**(for maintenance only)**

**⚠ WARNING: Explosion Hazard. Do not open the enclosure unless area is known to be non-hazardous.**

1. Turn the key clockwise from “Normal” to “Maintenance Bypass”. The system pressure is now bypassed directly from “inlet” to “process” port (C2) so that the process valve position is maintained (a lever option is available in place of the key).
2. Verify pressure switch #1 is closed and #2 and #3 are open, indicating the RCS is in bypass.

**⚠ WARNING: Remove the maintenance bypass key from the switch and place the key in the bottom of the enclosure until maintenance has been completed.**

**⚠ WARNING: Explosion Hazard. Do not remove or replace any component while circuit is live unless area is known to be non - hazardous.**

3. Turn off power to the RCS; disconnect appropriate wires from terminal block.
4. Remove device (coil, solenoid valve, or pressure switch) and install the new device following instructions supplied. If replacing a solenoid valve, apply a small amount of anti-seize to the bolt threads and torque to 160-175 in-lbs in a crisscross pattern. Reconnect wires to appropriate terminal, (see wiring diagrams provided with the RCS unit).
5. Turn on power to the RCS. Verify that each device has power and is in the correct state. (see Figure 9a and 9b).
6. Replace key in the Maintenance Bypass and rotate counter-clockwise to the “Normal” position.
7. Have the control room run through the programmed test to be sure the system is operating properly.

## Section 4.

### 1. Functional Test Certification

Once assembled and inspected the RCS is cycled through a generic program to validate two-out-of-two (2oo2) or one-out-of-one hot standby (1oo1 HS); shut down function; partial stroke function; solenoid valve status and pressure switch indication table; manual bypass function.

### 2. Spare Parts

**▲ WARNING: Replacement parts are only to be obtained from ASCO or an authorized distributor or the certifications may be invalidated or there may be a risk of explosion.**

VALVES AND COILS			
APPLICATION	VOLTAGE	VALVE	COIL
De-Energize-To-Trip	24/DC	323406	238714-902-D
Energize-To-Trip	24/DC	323407	238714-902-D
De-Energize-To-Trip	120/60-110/50	323404	238814-032-D
Energize-To-Trip	120/60-110/50	323405	238814-032-D
De-Energize-To-Trip	12/DC	323531	238714-903-D
Energize-To-Trip	12/DC	323530	238714-903-D
De-Energize-To-Trip	48/DC	323533	238714-912-D
Energize-To-Trip	48/DC	323532	238714-912-D
De-Energize-To-Trip	120/DC	323535	238714-904-D
Energize-To-Trip	120/DC	323534	238714-904-D
De-Energize-To-Trip	230/50-240/50	323537	238814-059-D
Energize-To-Trip	230/50-240/50	323536	238814-059-D
Bypass	ALL	323408	

PRESSURE SWITCHES	
Pressure Switch SPDT Silver Contacts	323401
Pressure Switch SPDT Gold Contacts	323400
Pressure Switch DPDT Silver Contacts	323378

### 3. Packaging

While the package for RCS is designed to handle 2x the weight of the unit, there are always hazards in shipping. Upon receipt of product, unpack and check the product against the packing slip. If there is damage to the product, immediately contact the Authorized ASCO sales representative.

### 4. Limited Warranty

**WARRANTIES:** The manufacturer warrants its products and equipment to be free from defects in material and workmanship for a period of one year from the date of shipment from its factory.

The Manufacturer is not responsible for damage to its products through normal wear and tear, improper installation, maintenance, use, repairs or adjustment, or attempts to operate it above its rated capacity or voltage, intentional or otherwise, or for unauthorized repairs. To the extent the Manufacturer has relied upon specifications, information, representation of operating conditions or other are supplied by Buyer or its agents to Seller in the selection or design of the goods, and the operation conditions or other conditions differ from those represented by the Buyer and relied upon by Manufacture, and warranties or other provisions contained herein which are affected by such conditions shall be null and void.

NO OTHER REPRESENTATION, GUARANTEES OR WARRANTIES, EXPRESSED OR IMPLIED, ARE MADE BY THE MANUFACTURE AND THE FOREGOING WARRANTY IS IN LIEU OF ALL OTHER REPRESENTATIONS AND WARRANTIES, EXPRESSED OR IMPLIED, WHICH ARE HEREBY EXPRESSLY DISCLAIMED AND WAIVED BY BUYER, INCLUDING ANY WARRANTY OF MERCHANTABILITY OR OF FITNESS FOR PARTICULAR PURPOSE, WHETHER OR NOT THE PURPOSE OR USE HAS BEEN DISCLOSED TO SELLER IN SPECIFICATION, DRAWING OR OTHERWISE, AND WHETHER OR NOT THE PRODUCT IS SPECIFICALLY DESIGNED AND/OR MANUFACTURED FOR BUYERS USE OF PURPOSE.

### Disclaimer

Because of the variety of uses for the ASCO Redundant Control System (RCS), the user and those responsible for applying this equipment must satisfy themselves as to the acceptability of the RCS for each application.

The illustrations in this manual are solely intended to illustrate the text of this manual. Because of the many variables and requirements associated with this particular installation, ASCO cannot assume responsibility or liability for actual use based upon the illustrative uses and applications.

In no event will ASCO be responsible or liable for indirect or consequential damages resulting from the use or application of this equipment. ASCO disclaims any implied warranties of merchantability or fitness for a particular purpose.

### ASCO DISCLAIMS ANY IMPLIED WARRANTY OR FITNESS FOR A PARTICULAR PURPOSE.

No patent or copyright liability is assumed by ASCO with respect to use of information, circuits, equipment or software described in this text.

Reproduction of the content of this manual, in whole or in part, without written permission from ASCO is prohibited.

### 5. Tools Required for Routine Service of RCS

**Multi-meter**

**6 mm hex key**

**1/4" hex key**

**3/16" hex key**

**Large slotted screwdriver**

**small slotted screwdriver**

**wire cutter/stripper**

**1 1/2" open end wrench**

# RCS Base Unit Wiring Diagram (A)

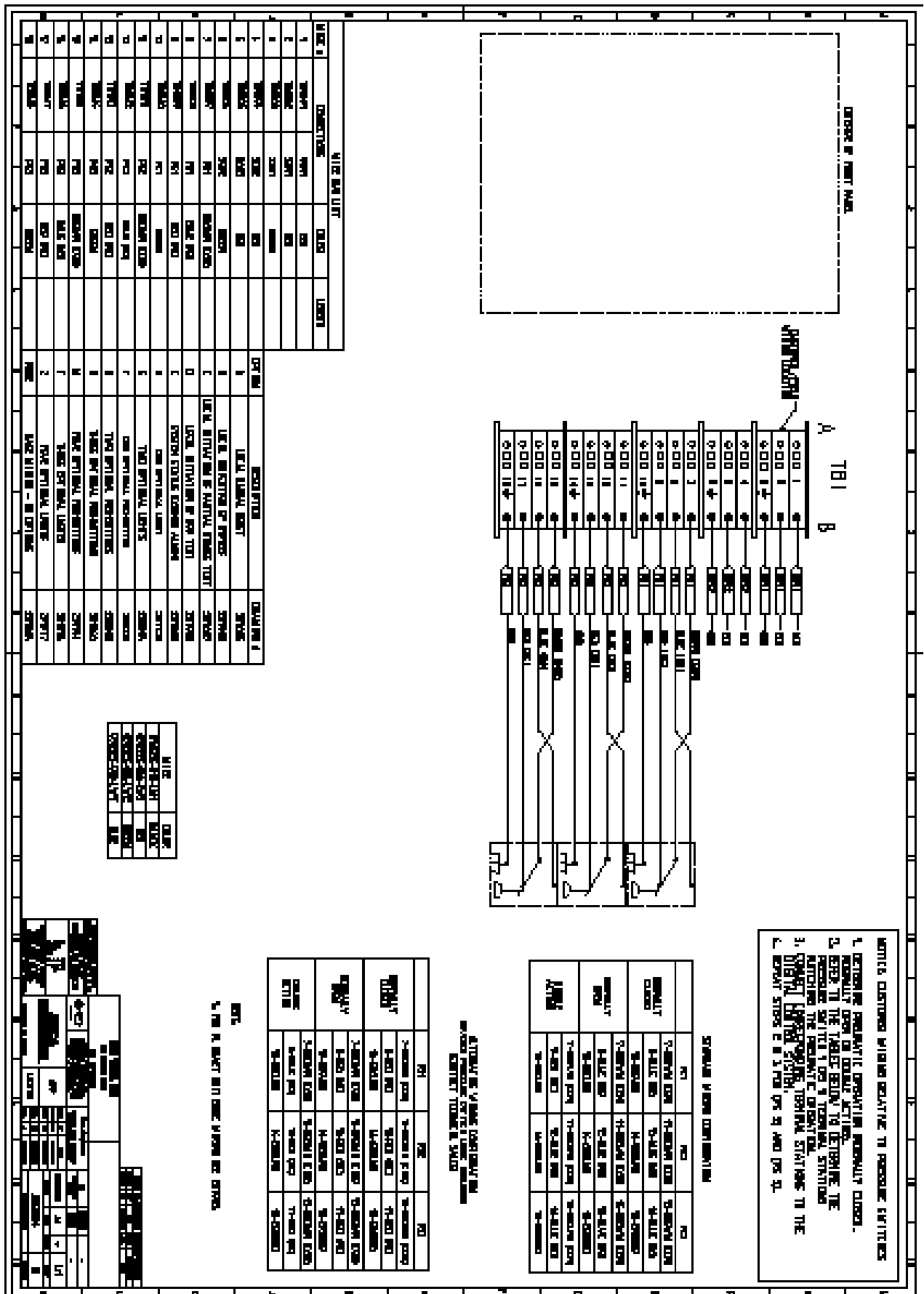

# RCS Base Unit wit PLC Wiring Diagrams (B)

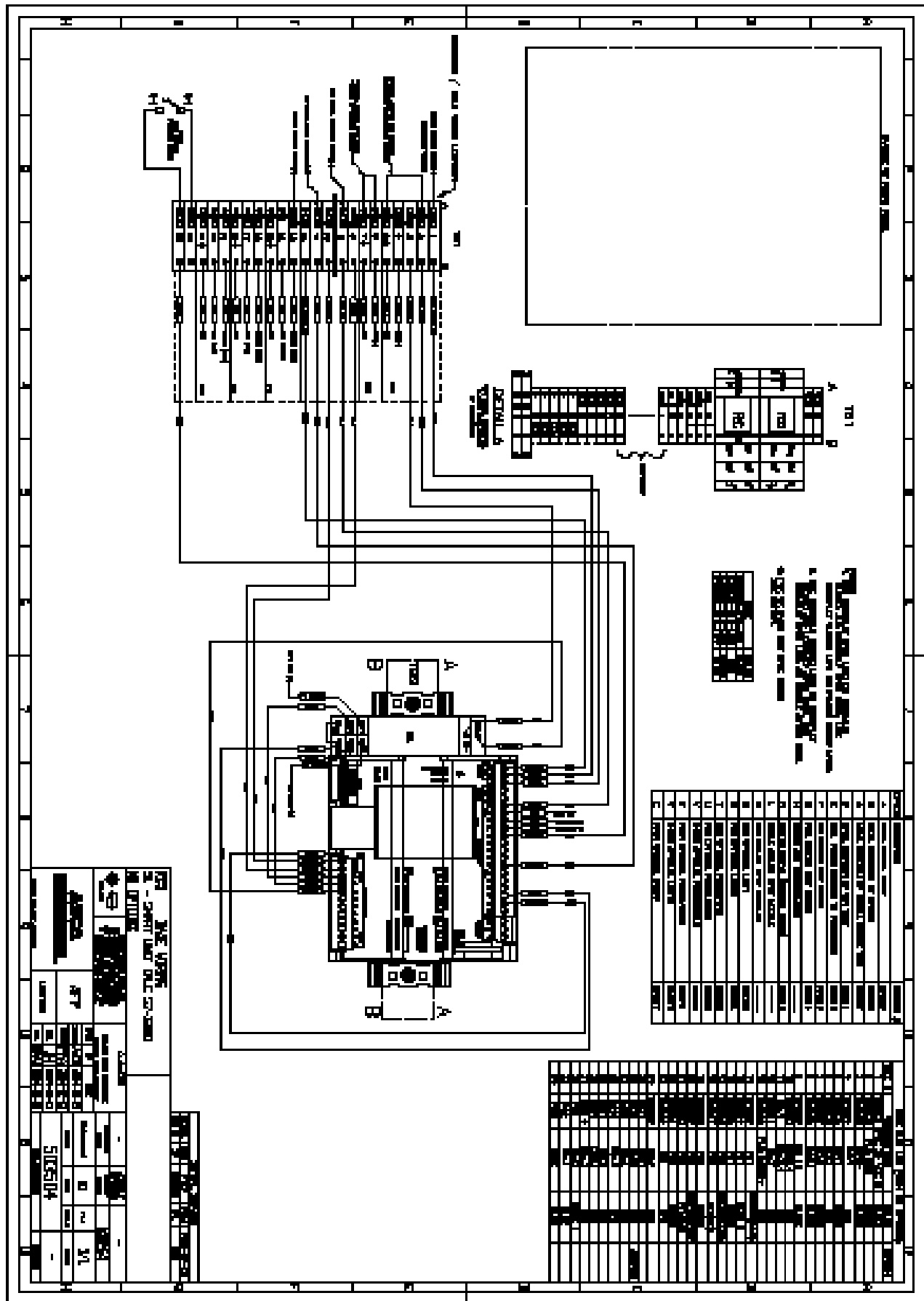



# RCS Normally Closed Piping Diagrams

RCS used as 3-way NC pilot valve with 40-150 psi instrument air supply required

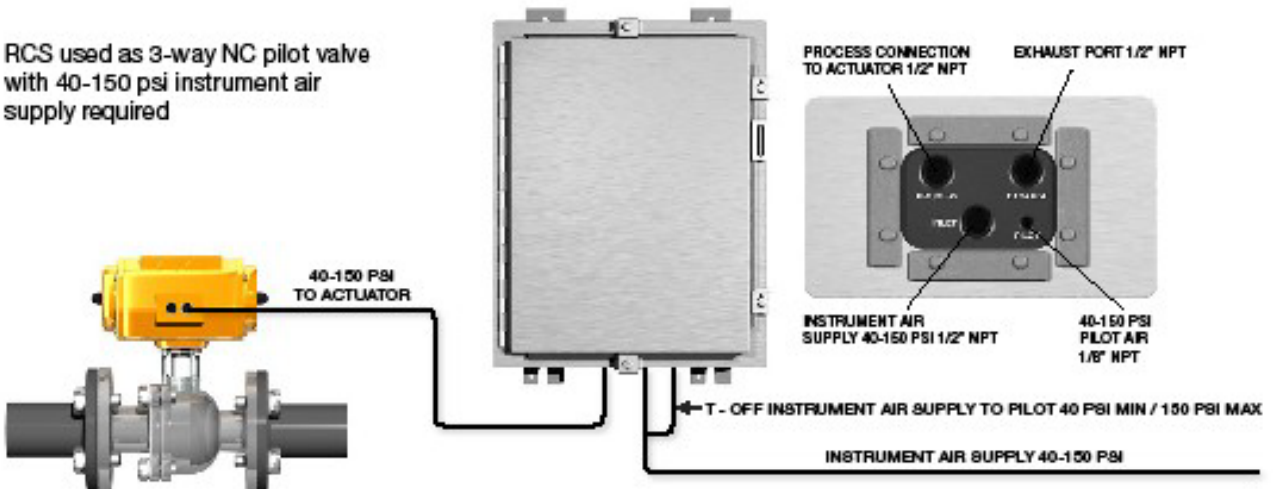

RCS used as 3-way NC pilot valve with 3-150 psi instrument air supply required

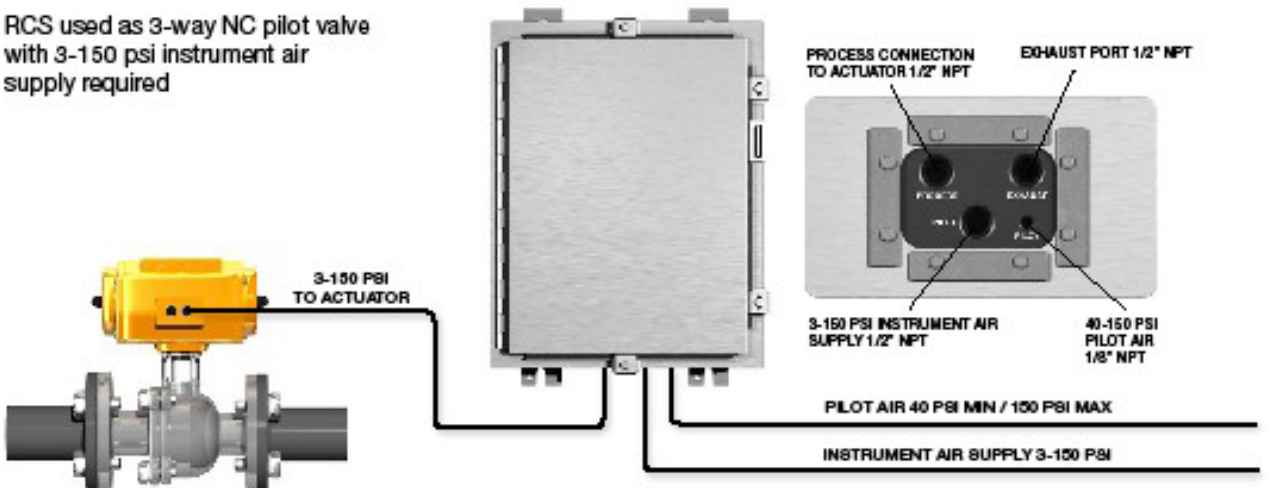

RCS used as 3-way NC pilot valve with valve controller

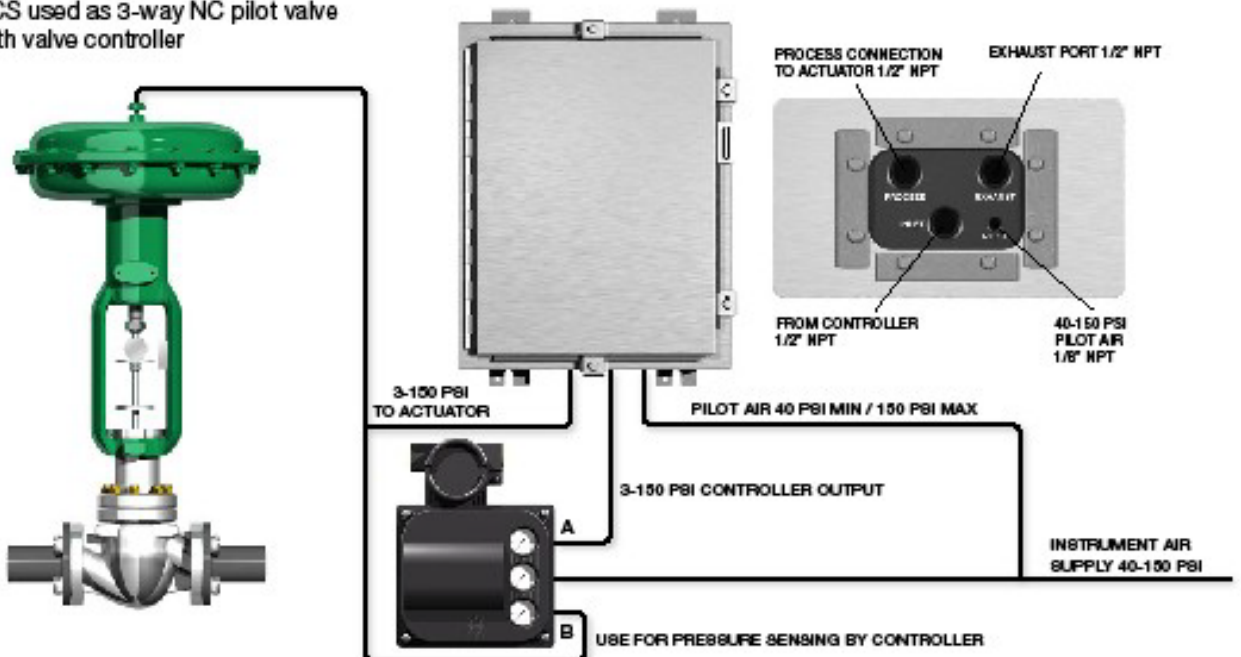

# RCS Normally Open Piping Diagrams

RCS used as 3-way NO pilot valve with 40-150 psi instrument air supply required

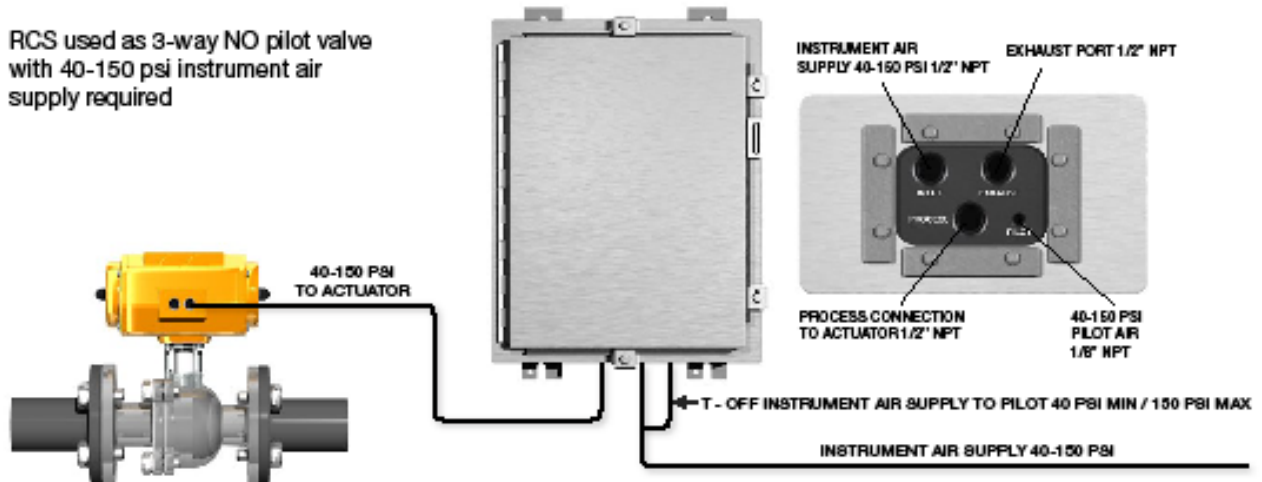

RCS used as 3-way NO pilot valve with 3-150 psi instrument air supply required

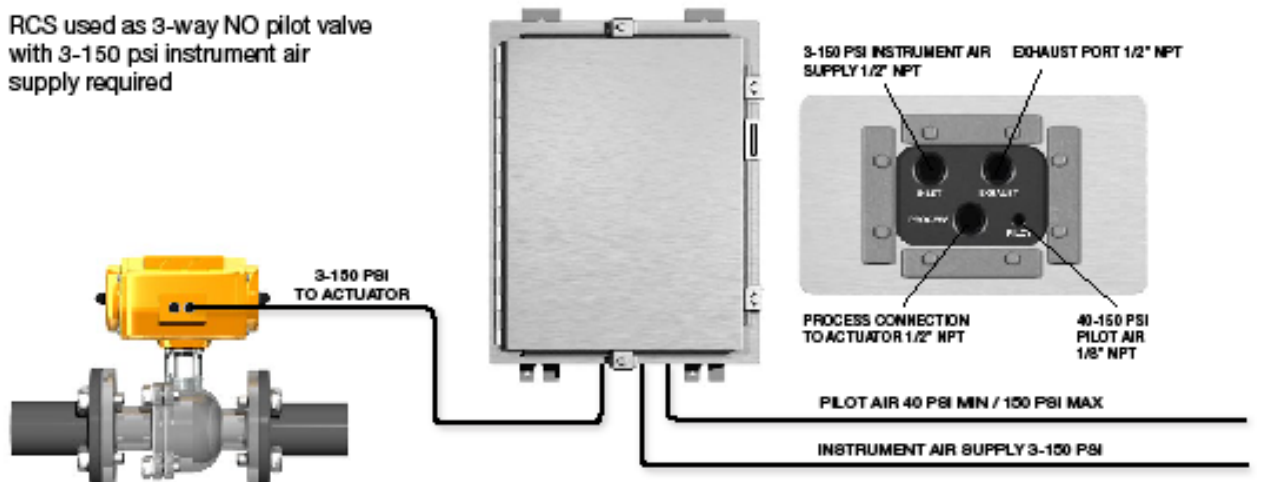

RCS used as 3-way NO pilot valve with valve controller

