

Fisher™ FIELDVUE™ DVC7K-H Digital Valve Controller



Table of Contents

Section 1: Introduction

1.1	Installation, Pneumatic and Electrical Connections and Initial Configuration.....	1
1.2	Scope of the Manual.....	1
1.3	Conventions Used in this Manual.....	1
1.4	Description.....	2
1.5	Specifications.....	3
1.6	Related Documents.....	6
1.7	Educational Services.....	6

Section 2: Security..... 7

Section 3: Wiring Practices

3.1	Control System Requirements.....	9
-----	----------------------------------	---

Section 4: Configuration

4.1	Guided Setup.....	13
4.2	Manual Setup.....	13
4.3	Specification Sheet.....	16
4.4	Tuning.....	31
4.5	Inputs.....	33
4.6	Outputs.....	34
4.7	Alert Setup.....	36

Section 5: Calibration

5.1	Travel Calibration.....	38
	Auto Calibration.....	38
	Manual Calibration.....	39
5.2	Sensor Calibration.....	41
	Pressure Sensor Calibration.....	41
	Input Current Calibration.....	43
5.3	Relay Adjustment.....	44

Section 6: Device Information, Diagnostics and Variables

6.1	Overview.....	46
	Status and Primary Purpose Variables.....	46
	Device Information.....	47
	Diagnostics.....	48
	Variables.....	55

Section 7: Maintenance and Troubleshooting

7.1	Removing the Magnetic Feedback Array Assembly	59
7.2	Component Replacement.....	59
	Tools Required	59
	I/P Converter	60
	Front Cover Assembly	62
	Pneumatic Relay	67
	Terminal Box	68
	Vent	70
	Gauge Block	72
7.3	Troubleshooting.....	73
	Checking Voltage Available	73
	Restore	74
7.4	DVC7K Technical Support Checklist.....	77

Section 8: Parts

8.1	Parts Ordering.....	79
8.2	Parts Kits.....	79
8.3	Pressure Gauges, Pipe Plugs or Tire Valve Assemblies.....	83

Appendix A: Principle of Operation

A.1	HART Communication.....	87
A.2	Control Tiers and Application Modes.....	88
A.3	DVC7K Digital Valve Controller	88

Appendix B: Handheld Communicator Menu Trees.....92

Appendix C: Local User Interface (LUI) Flow Chart

C.1	Overview	104
C.2	Configure.....	105
C.3	Service Tools	106

Appendix D: Third-Party Software Notices and Additional Terms and Conditions..... 107

Glossary.....110

Section 1: Introduction

1.1 Installation, Pneumatic and Electrical Connections and Initial Configuration

Refer to the DVC7K-H Quick Start Guide (D104766X012) for DVC7K installation, connection and initial configuration information. If a copy of this Quick Start Guide is needed, scan or click the QR code below, contact your [Emerson sales office](#), or visit our website at [Fisher.com](#).



Scan for Installation Documents and Field Support
emrson.co/FieldSupportDVC7K

1.2 Scope of the Manual

This instruction manual is a supplement to the DVC7K-H Quick Start Guide (D104766X012). This instruction manual includes product specifications, reference materials, custom setup information, maintenance procedures and replacement part details.

This instruction manual describes using an Emerson handheld communicator and the Local User Interface (LUI) to set up and calibrate the instrument.

⚠ WARNING

Do not install, operate or maintain a DVC7K digital valve controller without being fully trained and qualified in valve, actuator and accessory installation, operation and maintenance. To avoid personal injury or property damage, it is important to carefully read, understand and follow all contents of this manual, including all safety cautions and warnings. If you have any questions about these instructions, contact your [Emerson sales office](#) before proceeding.

1.3 Conventions Used in this Manual

Navigation paths are included for procedures and parameters that can be accessed using the Device Description (DD) with a handheld communicator or the Local User Interface (LUI).

For example, to access Guided Setup:

Handheld Communicator (DD)	Device Settings > Setup Overview > Guided Setup
Local User Interface (LUI)	Configure > Guided Setup

Refer to Appendix B for handheld communicator menu trees and Appendix C for the Local User Interface flow chart.

1.4 Description

DVC7K digital valve controllers (Figure 1 and 2) are communicating, microprocessor-based current-to-pneumatic instruments. In addition to the traditional function of converting an input current signal to a pneumatic output pressure, the DVC7K digital valve controller, using the HART® communications protocol, gives easy access to information critical to process operation. You can gain information from the principal component of the process, the control valve itself, using the Local User Interface (LUI) at the valve or a Device Description at the valve, at a field junction box or at the operator's console within the control room. Additionally, an option is available which provides isolated circuitry for a valve position transmitter (for separate valve position feedback) and two integrated switches that can be set as limit switches or alert switches.

Figure 1. FIELDVUE DVC7K Digital Valve Controller Mounted on a Fisher Sliding-Stem Valve Actuator



X1969-1

Figure 2. FIELDVUE DVC7K Digital Valve Controller Mounted to a Fisher 8590 Control Valve



X1975-2

Diagnostic information is available to aid you when troubleshooting. Input and output configuration parameters can be set and the digital valve controller can be calibrated.

Using the HART protocol, information from the field can be integrated into control systems or be received on a single loop basis.

The DVC7K digital valve controller is designed to directly replace standard pneumatic and electro-pneumatic valve mounted positioners.

1.5 Specifications

⚠ WARNING

Refer to Table 1 for specifications. Incorrect configuration of a positioning instrument could result in the malfunction of the product, property damage or personal injury.

Specifications for DVC7K digital valve controllers are shown in Table 1.

Table 1. Specifications

Available Mounting	Input Signal (continued)
<ul style="list-style-type: none"> ■ Direct actuator mounting to Fisher 657i/667i or GX actuators ■ Integral mounting to Fisher sliding-stem and rotary actuators ■ Quarter-turn rotary actuators <p>DVC7K digital valve controllers can also be mounted on other actuators that comply with IEC 60534-6-1, IEC 60534-6-2, VDI/VDE 3845 and NAMUR mounting standards.</p>	<p>24 V DC (On/Off only) Instrument Power: 11 to 30 V DC at 10 mA Reverse Polarity protected</p>
	Supply Pressure ⁽¹⁾
	<p>Minimum Recommended: 0.3 bar / 5 psig higher than maximum actuator requirements</p> <p>Maximum: 10.0 bar / 145 psig or maximum pressure rating of the actuator, whichever is lower</p>
Communication Protocol	Supply medium must be clean, dry and noncorrosive
HART 7	Per ISA Standard 7.0.01
Input Signal	A maximum 40 micrometer particle size in the air system is acceptable. Further filtration down to 5 micrometer particle size is recommended. Lubricant content is not to exceed 1 ppm weight (w/w) or volume (v/v) basis. Condensation in the air supply should be minimized.
<p>Point-to-Point Analog Input Signal: 4 to 20 mA DC, nominal; split ranging available</p> <p>Minimum voltage available at instrument terminals must be 10.2 V DC for analog control, 10.7 V DC for HART communication</p> <p>Minimum Control Current: 4.0 mA</p> <p>Minimum Current without Microprocessor Restart: 3.8 mA</p> <p>Maximum Voltage: 30 V DC</p> <p>Overcurrent protected</p> <p>Reverse Polarity protected</p>	<p>Pressure dew point: At least 10 °C less than the lowest ambient temperature expected</p> <p>Per ISO 8573-1</p> <p>Maximum particle density size: Class 7</p> <p>Oil content: Class 3</p> <p>Pressure dew point: Class 3</p>

- continued -

Table 1. Specifications (continued)

<p>Output Signal</p>	<p>General Electrical Safety - Environmental Conditions</p>
<p>Pneumatic signal, up to full supply pressure Maximum Span: 9.5 bar / 140 psig Action: ■ Double, ■ Single Direct or ■ Reverse</p>	<p>Use: Indoor and Outdoor Altitude: up to 2000 m Temperature: see operating ambient temperature limits Relative Humidity: Max. R.H 90 % non-condensing Supply Voltage Fluctuations: N/A, not connected to Mains Transient Overvoltage: Category I Pollution Degree: 2 Wet Locations: Yes</p>
<p>Steady-State Air Consumption⁽²⁾⁽³⁾</p> <p>At 1.4 bar / 20 psig supply pressure: Less than 0.38 normal m³/hr / 14 scfh At 5.5 bar / 80 psig supply pressure: Less than 1.3 normal m³/hr / 49 scfh</p>	<p>Vibration Testing Method</p> <p>Tested per ANSI/ISA-S75.13.01 Section 5.3.5.</p>
<p>Maximum Output Capacity⁽²⁾⁽³⁾</p> <p>At 1.4 bar / 20 psig supply pressure: 10.0 normal m³/hr / 375 scfh At 5.5 bar / 80 psig supply pressure: 29.5 normal m³/hr / 1100 scfh</p>	<p>Input Impedance</p> <p>An equivalent impedance of 550 ohms may be used. This value corresponds to 11 V at 20 mA.</p>
<p>Operating Ambient Temperature Limits⁽¹⁾⁽⁴⁾</p> <p>Standard: -40 to 85 °C / -40 to 185 °F includes nitrile elastomers Extreme Temperature Option: -45 to 85 °C / -49 to 185 °F includes fluorosilicone elastomers High Temperature Option: -40 to 85 °C / -40 to 185 °F includes fluorosilicone elastomers LCD may not be readable below -20 °C / -4 °F</p>	<p>Hazardous Area Approvals</p> <p>cCSAus - Intrinsically Safe, Explosion-proof, Dust-Ignition-proof, Increased Safety, Class/Div/Zone ATEX - Intrinsically Safe, Flameproof, Dust-Ignition-proof, Increased Safety IECEx - Intrinsically Safe, Flameproof, Dust-Ignition-proof, Increased Safety NEPSI (Pending) - Intrinsically Safe, Flameproof, Dust-Ignition-proof, Increased Safety</p> <p>Not all certifications apply to all constructions. Contact your Emerson sales office or refer to the DVC7K product page at Fisher.com for approval specific information.</p>
<p>Independent Linearity⁽⁵⁾</p> <p>Typical Value: ±0.5% of output span</p>	<p>Electrical Housing</p> <p>cCSAus - Type 4X, IP66 ATEX - IP66 IECEx - IP66</p>
<p>Electromagnetic Compatibility</p> <p>Meets EN IEC 61326-1:2021 Immunity — Industrial locations per Table 2 of the EN 61326-1 standard. Emissions — Class A ISM equipment rating: Group 1, Class A.</p>	

- continued -

Table 1. Specifications (continued)

Connections	Options
Supply Pressure: 1/4 NPT internal or G1/4 and integral pad for mounting 67CFR regulator Output Pressure: 1/4 NPT internal or G1/4 Tubing: 3/8 in. recommended Vent: 1/2 NPT internal Electrical: 1/2 NPT internal or M20	<ul style="list-style-type: none"> ■ Integral mounted filter regulator ■ Low-Bleed Relay⁽⁷⁾ ■ Extreme Temperature ■ High Temperature ■ Integral 4 to 20 mA Position Transmitter⁽⁸⁾⁽⁹⁾ ■ Integral Switches⁽¹⁰⁾⁽¹¹⁾ ■ Pipe-away Vent Connection
Actuator Compatibility	Declaration of SEP
Stem Travel (Sliding-Stem Linear): Linear actuators with rated travel between 6.35 mm / 0.25 in. and 606 mm / 23.375 in. Shaft Rotation (Quarter-Turn Rotary): Rotary actuators with rated travel between 45° and 180° ⁽⁶⁾	Fisher Controls International LLC declares this product to be in compliance with Article 4 paragraph 3 of the PED Directive 2014/68/EU and Part 1, Requirement 8 of the PESR Regulation. It was designed and manufactured in accordance with Sound Engineering Practice (SEP) and cannot bear the CE marking related to PED compliance or the UKCA mark related to the PESR Regulation. However, the product may bear the CE or UKCA marking to indicate compliance with other applicable European Community Directives or UK Regulations (Statutory Instruments).
Weight	
Aluminum: 3.9 kg / 8.9 lbs	
Control Tier	
Throttling Control (TC): Supports Throttling and On/Off Application Modes Discrete Control (DC): Supports On/Off Application Mode only	
<p>NOTES: Specialized instrument terms are defined in ANSI/ISA Standard 51.1 - Process Instrument Terminology.</p> <ol style="list-style-type: none"> 1. The pressure/temperature limits in this document and any other applicable code or standard should not be exceeded. 2. Normal m³/hour - Normal cubic meters per hour at 0 °C and 1.01325 bar, absolute. Scfh - Standard cubic feet per hour at 60 °F and 14.7 psia. 3. Values at 1.4 bar / 20 psig based on a single-acting direct relay; values at 5.5 bar / 80 psig based on double-acting relay. 4. Temperature limits vary based on hazardous area approval. 5. Not applicable for travels less than 19 mm / 0.75 in. or for shaft rotation less than 60 degrees. Also not applicable for digital valve controllers in long-stroke applications. 6. Rotary actuators with 180 degree rated travel require a special mounting kit; contact your Emerson sales office for kit availability. 7. The Quad O steady-state consumption requirement of 6 scfh can be met by a DVC7K with low bleed relay A option, when used with up to 4.8 bar / 70 psi supply of Natural Gas at 16 °C / 60 °F. The 6 scfh requirement can be met by low bleed relay B and C when used with up to 5.2 bar / 75 psi supply of Natural Gas at 16 °C / 60 °F. 8. 4 to 20 mA output, isolated; Supply Voltage: 11 to 30 V DC; Reference Accuracy: 1% of travel span. 9. Position transmitter meets the requirements of NAMUR NE43; selectable to show failure low (< 3.6 mA) or failure high (> 22.5 mA). Fail high available only when the instrument is powered. 10. Two isolated switches, configurable throughout the calibrated travel range or actuated from a device alert. Off State: 0 mA (nominal); On State: up to 1 A; Supply Voltage: 30 V DC maximum; Reference Accuracy: 2% of travel span. 11. Switch 1 is a normally open circuit and Switch 2 is a normally closed circuit. 	

1.6 Related Documents

This section lists other documents containing information related to the DVC7K digital valve controller. These documents include:

- Fisher FIELDVUE DVC7K-H Digital Valve Controller Product Bulletin ([D104765X012](#))
- Fisher FIELDVUE DVC7K-H Digital Valve Controller for On/Off Applications Product Bulletin ([D104791X012](#))
- Fisher FIELDVUE DVC7K Digital Valve Controller and Magnet Array Dimensions ([D104795X012](#))
- Fisher FIELDVUE DVC7K-H Digital Valve Controller Quick Start Guide ([D104766X012](#))
- North American Hazardous Area Approvals, Fisher FIELDVUE DVC7K-H Digital Valve Controllers ([D104770X012](#))
- IECEx/ATEX/UKEX Hazardous Area Approvals, Fisher FIELDVUE DVC7K-H-C-D Digital Valve Controllers ([D104771X012](#))
- HART Field Device Specification for FIELDVUE DVC7K ([D104788X012](#))
- FIELDVUE Digital Valve Controller Split Ranging ([D103262X012](#))
- Implementation of Lock-in-Last Strategy ([D103261X012](#))
- Using FIELDVUE Instruments with the Smart Wireless THUM Adapter and a HART Interface Module (HIM) ([D103469X012](#))
- Using FIELDVUE Instruments with the Smart HART Loop Interface and Monitor (HIM) ([D103263X012](#))
- Audio Monitor for HART Communications ([D103265X012](#))
- Fisher HF340 Filter Instruction Manual ([D102796X012](#))
- Fisher LC340 Line Conditioner Instruction Manual ([D102797X012](#))
- AMS Trex Device Communicator [User Guide](#)

All documents are available from your [Emerson sales office](#) or at [Fisher.com](#).

1.7 Educational Services

Emerson Educational Services
Phone: +1-800-338-8158
e-mail: education@emerson.com
emerson.com/mytraining

Section 2: Security

NOTICE

Physical security is an important part of any security program and is fundamental to protecting your system. Unauthorized personnel may potentially cause significant damage to and/or misconfiguration of end users equipment. This could be intentional or unintentional and must be protected against by restricting access of unauthorized personnel in your facility.

- The DVC7K digital valve controller has several features to help protect against unintentional configuration changes:
 - DVC7K Signed Firmware
 - Write Protection (page 15)
 - Cannot be connected directly to a network and cannot access the worldwide internet
- If physically unsecured, any device in the field is vulnerable to a physical attack; safety and security procedures must include mitigation by physical security controls.
- The following are unsecured, unencrypted inputs and outputs used by the DVC7K digital valve controller:
 - Input signal
 - Outputs - two solid state dry contact switches and one position transmitter

NOTE

Outputs only applicable if the device was purchased with I/O options.

- Supply pressure
- Output pressure to actuator
- HART - used for digital communication
- Local User Interface (LUI) and LED indicator - used for local calibration
- The following are secured inputs and outputs used by the DVC7K digital valve controller:
 - Internal serial port - intended for only Emerson personnel's use to upgrade firmware.
- The DVC7K has optional applications for configuration and data viewing. When such applications are used, they must run on devices that are configured according to local security policies.
- The device has been developed using secure coding principles and procedures, including threat modeling and security specific testing. It has several interfaces for configuration, with each of them having an option to disable write options.
- There are multiple ways to configure the device, including:
 - The Local User Interface (LUI).
 - The FDI (Field Device Integration) package or DD (Device Description) used with asset manager software such as AMS Device Manager or a handheld communicator such as Emerson Trex.

- Product Operation Best Practices:
 - Ensure that operation personnel are trained both on local security policies and the secure operation of the DVC7K digital valve controller.
 - It is recommended that you enable write protection after configuration is complete.
 - Operate the device within a controlled and secured physical environment.
 - Operate the DVC7K digital valve controller and the FDI package/DD host within a controlled and secured network environment.
 - Configure the FDI package/DD host to allow users to have least privilege access to the DVC7K digital valve controller, providing access to only what is absolutely required to perform their job function.
 - Apply security patches and updates as they are released.
-

NOTE

Work with your [Emerson sales office](#) to stay informed and obtain access to security patches and updates.

- Report security incidents and potential product vulnerabilities at:
https://go.emersonautomation.com/reportvulnerability_en
- Password Management Best Practices:
 - Manage FDI package/DD host user passwords per local security policy.
- Product Disposal Guidelines

When the device needs to be disposed of, consider the following aspects of device removal:

- Identify whether the device can be reused in another part of the process or for testing or training purposes.
 - Sanitize the following data stored on the instrument with the latest industry recommended methods.
1. Spec Sheet/Configuration Data: To restore the configuration back to factory defaults, run the Restore Factory Configuration method defined on page 74. Review the Specification Sheet parameters with the FDI (Field Device Integration) package or DD (Device Description) to verify all configuration parameters with sensitive data are removed.
 2. Event Log Data: Open the Event Log with the FDI (Field Device Integration) package or DD (Device Description) and run the Clear Event Log method.
-

NOTE

The Emerson diagnostic dataset(s) and debug logs will not be removed with the above steps and will remain on the device. However, no process related information is contained in this data.

If the device will not be reused, follow local disposal policy.

Section 3: Wiring Practices

3.1 Control System Requirements

There are several parameters that should be checked to ensure the control system is compatible with the DVC7K digital valve controller.

HART Filter/Line Conditioner

Depending on the logic solver or control system and Application Mode of the DVC7K digital valve controller, a line conditioner or HART filter may be required. See Table 2.

NOTE

The DVC7K is not a SIL capable device.

Table 2. HART Filter/Line Conditioner Requirement by System and Mode

Application Mode	Control System or Logic Solver	HART Filter Required?	Line Conditioner Required?
4 to 20 mA Point-to-Point Loop	PROVOX™, RS3™, DeltaV™, Ovation™	No	No
	All Others	Consult Sales Office	No
24 V DC Multi-Drop Loop	All	No	Yes

The HF340 HART filter and LC340 Line Conditioner are passive devices that are inserted in the field wiring of the HART loop. A filter or line conditioner is normally installed near the field wiring terminals of the system I/O (see Figure 3). Its purpose is to effectively isolate the system output from modulated HART communication signals and raise the impedance of the system to allow HART communication. For more information, refer to the HF340 HART filter (D102796X012) or LC340 Line Conditioner (D102797X012) instruction manual.

Voltage Available

The voltage available at the DVC7K digital valve controller must be at least 10.5 V DC. The voltage available at the instrument is not the actual voltage measured at the instrument when the instrument is connected. The voltage measured at the instrument is limited by the instrument and is typically less than the voltage available.

As shown in Figure 3, the voltage available at the instrument depends upon:

- the control system compliance voltage
- if a filter, wireless THUM adapter or intrinsic safety barrier is used, and
- the wire type and length.

The control system compliance voltage is the maximum voltage at the control system output terminals at which the control system can produce maximum loop current.

Figure 3. Determining Voltage Available at the Instrument

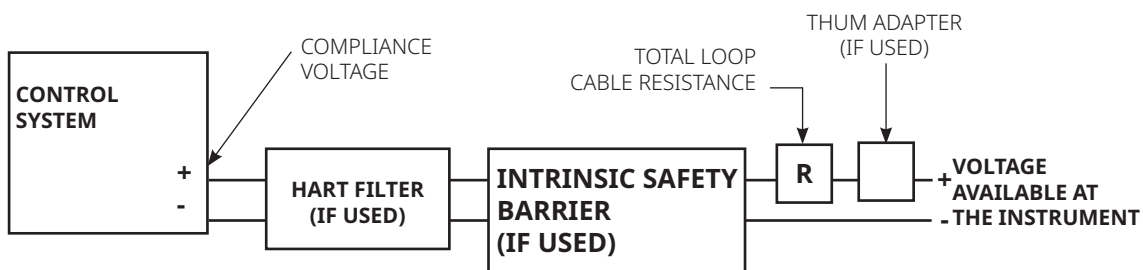

Calculate Voltage Available at the Instrument as follows:

- Control system compliance voltage
- Filter voltage drop (if used)⁽¹⁾
- Intrinsic safety barrier resistance (if used) x maximum loop current
- Smart Wireless THUM adapter voltage drop (if used)⁽²⁾
- Total loop cable resistance x maximum loop current

= Voltage available at the instrument⁽³⁾

Example Calculation

- 18.5 V (at 21.05 mA)
- 2.3 V (for HF340 filter)
- 2.55 V (121 ohms x 0.02105 A)
- 1.01 V (48 ohms x 0.02105 A for 1000 feet of Belden 9501 cable)
- = 15.19 V, available — if safety barrier (2.55 V) is not used

Notes:

1. Obtain filter voltage drop. The measured drop will be different than this value. The measured filter voltage drop depends upon control system output voltage, the intrinsic safety barrier (if used), and the instrument. See Note 3.
2. The voltage drop of the THUM adapter is linear from 2.25 V at 3.5 mA to 1.2 V at 25 mA.
3. The voltage available at the instrument is not the voltage measured at the instrument terminals. Once the instrument is connected, the instrument limits the measured voltage to approximately 8.0 to 9.5 V.

The voltage available at the instrument may be calculated from the following equation:

$$\text{Voltage Available} = [\text{Control System Compliance Voltage (at maximum current)}] - [\text{filter voltage drop (if a HART filter is used)}] - [\text{total cable resistance} \times \text{maximum current}] - [\text{barrier resistance} \times \text{maximum current}].$$

The calculated voltage available should be greater than or equal to 10.5 V DC.

Table 3 lists the resistance of some typical cables.

The following example shows how to calculate the voltage available for a Honeywell™ TDC2000 control system with a HF340 HART filter and 1000 feet of Belden™ 9501 cable:

$$\text{Voltage available} = [18.5 \text{ V (at 21.05 mA)}] - [2.3 \text{ V}] - [48 \text{ ohms} \times 0.02105 \text{ A}]$$

$$\text{Voltage available} = [18.5] - [2.3] - [1.01]$$

$$\text{Voltage available} = 15.19 \text{ V}$$

Table 3. Cable Characteristics

Cable Type	Capacitance ⁽¹⁾ pF/Ft	Capacitance ⁽¹⁾ pF/m	Resistance ⁽²⁾ Ohms/ft	Resistance ⁽²⁾ Ohms/m
BS5308/1, 0.5 sq mm	61.0	200	0.022	0.074
BS5308/1, 1.0 sq mm	61.0	200	0.012	0.037
BS5308/1, 1.5 sq mm	61.0	200	0.008	0.025
BS5308/2, 0.5 sq mm	121.9	400	0.022	0.074
BS5308/2, 0.75 sq mm	121.9	400	0.016	0.053
BS5308/2, 1.5 sq mm	121.9	400	0.008	0.025
BELDEN 8303, 22 awg	63.0	206.7	0.030	0.098
BELDEN 8441, 22 awg	83.2	273	0.030	0.098
BELDEN 8767, 22 awg	76.8	252	0.030	0.098
BELDEN 8777, 22 awg	54.9	180	0.030	0.098
BELDEN 9501, 24 awg	50.0	164	0.048	0.157
BELDEN 9680, 24 awg	27.5	90.2	0.048	0.157
BELDEN 9729, 24 awg	22.1	72.5	0.048	0.157
BELDEN 9773, 18 awg	54.9	180	0.012	0.042
BELDEN 9829, 24 awg	27.1	88.9	0.048	0.157
BELDEN 9873, 20 awg	54.9	180	0.020	0.069
1. The capacitance values represent capacitance from one conductor to all other conductors and shield. This is the appropriate value to use in the cable length calculations.				
2. The resistance values include both wires of the twisted pair.				

Compliance Voltage

If the compliance voltage of the control system is not known, perform the following compliance voltage test.

1. Disconnect the field wiring from the control system and connect equipment as shown in Figure 4 to the control system terminals.
2. Set the control system to provide maximum output current.
3. Increase the resistance of the 1 k Ω potentiometer, shown in Figure 4, until the current observed on the milliammeter begins to drop quickly.
4. Record the voltage shown on the voltmeter. This is the control system compliance voltage.

For specific parameter information relating to your control system, contact your [Emerson sales office](#).

Figure 4. Voltage Test Schematic

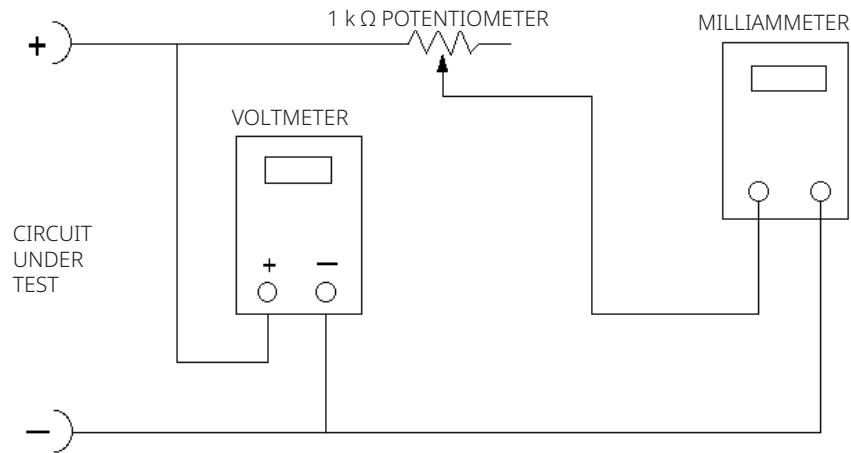

A6192-1

Maximum Cable Capacitance

The maximum cable length for HART communication is limited by the characteristic capacitance of the cable. Maximum length due to capacitance can be calculated using the following formulas:

$$\text{Length(ft)} = [160,000 - C_{\text{master}}(\text{pF})] \div [C_{\text{cable}}(\text{pF/ft})]$$

$$\text{Length(m)} = [160,000 - C_{\text{master}}(\text{pF})] \div [C_{\text{cable}}(\text{pF/m})]$$

where:

160,000 = a constant derived for FIELDVUE instruments to ensure that the HART network RC time constant will be no greater than 65 μs (per the HART specification).

C_{master} = the capacitance of the control system or HART filter

C_{cable} = the capacitance of the cable used (see Table 3)

The following example shows how to calculate the cable length for a Foxboro™ I/A control system (1988) with a C_{master} of 50,000 pF and a Belden 9501 cable with characteristic capacitance of 50pF/ft.

$$\text{Length(ft)} = [160,000 - 50,000\text{pF}] \div [50\text{pF/ft}]$$

$$\text{Length} = 2200 \text{ ft.}$$

The HART communication cable length is limited by the cable characteristic capacitance. To increase cable length, select a wire with lower capacitance per foot. Contact your Emerson sales office for specific information relating to your control system.

Section 4: Configuration

4.1 Guided Setup

Handheld Communicator (DD)	Device Settings > Setup Overview > Guided Setup
Local User Interface (LUI)	Configure > Guided Setup

To quickly setup the instrument, Guided Setup will guide you through the following steps.

1. **Select the Language** (LUI only).
2. **Provide Construction Information** which is used to configure the unique parameters for the actuator, instrument and accessory construction.
3. **Relay Adjustment** (Relay A only)
4. **Auto Calibration** is used to establish the limits of physical travel. During this process, the valve will fully stroke from one travel extreme to the other.
5. **Apply Custom Configuration** (factory purchased custom configurations only).
6. **Return to Previous State** (Instrument Mode and Write Protection).

NOTE

Refer to the DVC7K Quick Start Guide ([D104766X012](#)) for detailed instructions on Guided Setup.

4.2 Manual Setup

Handheld Communicator (DD)	Device Settings > Setup Overview
Local User Interface (LUI)	Configure

Manual Setup allows you to configure the digital valve controller to your application. Table 4 lists the default settings for a standard factory configuration. You can adjust actuator response, set the various modes, alerts, ranges, travel cutoffs and limits. You can also change the Write Protection mode.

NOTE

Refer to Table 11 for Default Alert Settings.

Table 4. Default Parameter Configuration

	Setup Parameter	Default Setting ⁽¹⁾
Instrument Configuration	Tag	[truncated serial number]
	Long Tag	[truncated serial number]
	Setpoint Source	Input Current
	Restart Setpoint Option	No effect
	Input Range Low	0%
	Input Range High	100%
	Input Current Units ⁽²⁾	%
	Polling Address	0
	Temperature Unit ⁽²⁾	Fahrenheit (°F)
	Pressure Unit ⁽²⁾	psi
	Zero Power Condition ⁽²⁾	Closed
	Application Mode ⁽²⁾⁽³⁾	Throttling
	Travel Sensor Motion	Counterclockwise/Toward Top of Instrument
Local User Interface	Language ⁽²⁾	English
	Decimal Separator ⁽²⁾	Period
	LED Setup ⁽²⁾⁽⁴⁾	LED Enable
Dynamic Response and Tuning	Input Characterization	Linear
	Tuning Set ⁽²⁾	H
	Travel Integral Deadzone	0.25%
	Travel Integral Gain	9.6 repeats/minute
	Travel Limit High Point	125%
	Cutoff High Trip Point	99.5%
	Cutoff Rate High	0.0%/sec
	Travel Limit Low Point	-25%
	Cutoff Low Trip Point	0.5%
Cutoff Rate Low	0.0%/sec	
1. The settings listed are for standard factory configuration. DVC7K instruments can also be ordered with custom configuration settings. Refer to the order requisition for the custom settings. 2. Configurable with the LUI. 3. Only user configurable if the Control Tier is Throttling Control. 4. Not configurable with the DD.		

NOTE

Refer to Appendix B for Handheld Communicator Menu Trees.

Mode and Protection

Handheld Communicator (DD)	Device Settings > Setup Overview Device Settings > Input/Output Device Settings > Communication Device Settings > Display Device Settings > Tuning
Local User Interface (LUI)	Configure > Instrument Mode Configure > Security > Write Protect

Instrument Mode

There are three instrument modes for the DVC7K; Automatic (AUTO), Manual (MAN) and Local Override (Override).

- Automatic is the normal operating mode such that the instrument follows the control signal.
- Manual is required in some cases to modify configuration parameters or to run diagnostics.
- Local Override occurs either when the device latches to the Zero Power Condition on startup or when the input current is too low while the Instrument Mode is in Manual. If the instrument is latched to the Zero Power Condition, change the Instrument Mode to Manual to clear the latch. If the input current is too low, increase the input current to clear the latch.

NOTE

In the DVC6200 digital valve controller, Automatic was referred to as In Service and Manual was referred to as Out of Service.

NOTE

Some changes that require the instrument to be in Manual will not take effect until the instrument is placed back in Automatic or the instrument is restarted.

Write Protection

There are three Write Protection modes for the DVC7K: Off, On with LUI Validation and On without LUI Validation.

The default setting is Off. If Write Protection is On with LUI Validation, the device prevents configuration and calibration changes to the instrument and can only be turned Off from the LUI. If Write Protection is On without LUI Validation, the device prevents configuration and calibration changes to the instrument but can be turned Off from the LUI or from a handheld communicator.

4.3 Specification Sheet

Configure the following Instrument parameters in the Device Description:

Positioner

Handheld Communicator (DD)

Device Settings > Setup Overview > Positioner

Identification

- **Tag** — A tag name up to 8 characters is available for the instrument. The Tag is the easiest way to distinguish between instruments in a multi-instrument environment. Use the Tag to label instruments electronically according to the requirements of your application. The Tag you assign is automatically displayed when the Device Description establishes contact with the digital valve controller.
- **Long Tag** — A Long Tag name up to 32 characters is available for the instrument. The Long Tag functions exactly like Tag.
- **Polling Address** — If the digital valve controller is used in point-to-point operation, the Polling Address is 0. When several devices are connected in the same loop, such as for split ranging, each device must be assigned a unique polling address. The Polling Address is set to a value between 0 and 63 for HART 7. To change the polling address, the instrument must be in Manual.
- **Manufacturer** — The manufacturer of the positioner
- **Device Type** — The Device Type for the positioner
- **Instrument Serial Number** — Enter the serial number on the instrument nameplate, up to 12 characters.
- **Device Identifier** — A unique identifier for the positioner
- **Message** — Enter any message with up to 32 characters. Message provides the most specific user-defined means for identifying individual instruments in multi-instrument environments.
- **Descriptor** — Enter a description for the application with up to 16 characters. The description provides a longer user-defined electronic label to assist with more specific instrument identification than is available with the HART tag.

Tiers

- **Control Tier** — There are two tiers: Throttling Control (TC) and Discrete Control (DC). TC supports both throttling and on/off application modes whereas DC only supports the on/off application mode.
- **Application Mode** — If the Control Tier is TC, users can take the instrument into Manual mode and select if the instrument behaves as a throttling or on/off valve.

Revisions

- Hardware Revision — Revision number of the instrument hardware.
- Device Revision — Revision number of the device.
- HART Protocol Revision — Revision number of the HART protocol.
- Main Firmware Revision — Revision number of the firmware and the date that firmware revision was released.
- Software Revision — Revision number of the Device Description (DD).

Units

- Pressure — Defines the output and supply pressure units in either psi, bar, kPa or kg/cm².
- Temperature — Degrees Fahrenheit or Celsius. The temperature measured is from a sensor mounted on the digital valve controller's printed circuit board.
- Input Current — Permits defining the Input Current units in mA or percent of 4 to 20 mA range.

Instrument Time

- Edit Instrument Time Method — The method, Edit Instrument Time, permits setting the instrument clock. When alerts are stored in the alert record, the record includes the time and date. The instrument clock uses a 24-hour format.
- Current Date — Displays the instrument clock's current date.
- Current Time — Displays the instrument clock's current time.

Positioner Performance

Handheld Communicator (DD)

Device Settings > Setup Overview > Positioner Performance

Travel Control

- Input Current — Displays the current input current.
- Relay Type — There are sixteen relay options to select from. The relay type is printed on the label affixed to the relay body. The label will indicate whether the relay is a low bleed and/or an extreme temperature version.

Standard Relays

1. Relay C
2. Relay B
3. Relay A as Double
4. Relay A as Single

Low Bleed Relays

5. Relay C LB
6. Relay B LB
7. Relay A LB as Double
8. Relay A LB as Single

Extreme Temperature Relays

- 9. Relay C XT
- 10. Relay B XT
- 11. Relay A XT as Double
- 12. Relay A XT as Single

Extreme Temperature and Low Bleed Relays

- 13. Relay C XTLB
 - 14. Relay B XTLB
 - 15. Relay A XTLB as Double
 - 16. Relay A XTLB as Single
- Zero Power Condition — The position of the valve (open or closed) when the electrical power to the instrument is removed. Zero Power Condition (ZPC) is determined by relay type, as shown in Figure 5.

Figure 5. Zero Power Condition



Relay Type	Loss of Electrical Power
Single-Acting Direct (Relay A or C)	Port A pressure to zero
Single-Acting Reverse (Relay B)	Port B pressure to full supply
Double-Acting (Relay A)	Port B pressure to full supply

- Restart Latch Options — There are two Restart Latch Options: Off or Zero Power. If Zero Power is selected, on power loss the device will move and latch to the Zero Power Condition on power up and will require you to unlatch it.
- Restart Latch Status — Identifies in the Restart Latch is Inactive or Active.

Cutoff/Limit High

- Cutoff/Limit High Action — Allows the user to control the behavior when the setpoint is high. Users have the following options: disabled, cutoff or limit.
- Cutoff High Trip Point — This is the point within the calibrated travel range above which the Cutoff is in effect when Cutoff/Limit High Action is Cutoff. A Cutoff High Trip Point of 99.5% is recommended to ensure the valve goes fully open.
- Travel Limit High Point — The maximum value that the setpoint will reach when the Cutoff/Limit High Action is set to Limit.
- Cutoff Rate High — This setting allows the valve to ramp at the configured rate to the high travel extreme when the Cutoff High Trip Point is reached. This provides a controlled ramp into the open travel stop.

Cutoff/Limit Low

- Cutoff/Limit Low Action — Allows the user to control the behavior when the setpoint is low. Users have the following options: disabled, cutoff or limit.
- Cutoff Low Trip Point — This is the point within the calibrated travel range below which the Cutoff is in effect when Cutoff/Limit Low Action is Cutoff. A Cutoff Low Trip Point of 0.5% is recommended to help ensure maximum shutoff seat loading.
- Travel Limit Low Point — The minimum value that the setpoint will reach when the Cutoff/Limit Low Action is set to Limit.
- Cutoff Rate Low — This setting allows the valve to ramp at the configured rate to the low travel extreme when the Cutoff Low Trip Point is reached. This provides a controlled ramp into the seat in order to minimize seat damage.

Characterization (Throttling Application Mode Only)

- Input Characterization

Input Characterization defines the relationship between the travel target and ranged set point. Ranged set point is the input to the characterization function. If the zero power condition equals closed, then a set point of 0% corresponds to a ranged input of 0%. If the zero power condition equals open, a set point of 0% corresponds to a ranged input of 100%. Travel target is the output from the characterization function.

Users can select from the three fixed input characteristics shown in Figure 6 (Linear, Equal Percentage or Quick Opening) or select a Custom characteristic. Figure 6 shows the relationship between the travel target and ranged set point for the fixed input characteristics, assuming the Zero Power Condition is configured as closed.

With input characterization, you can modify the overall characteristic of the valve and instrument combination. Selecting an equal percentage, quick opening or custom (other than the default of linear) input characteristic modifies the overall valve and instrument characteristic. However, if you select the linear input characteristic, the overall valve and instrument characteristic is the characteristic of the valve, which is determined by the valve trim (i.e., the plug or cage).

- Custom Characterization Table

You can specify two 21 point characterizations on a custom characteristic curve. Each point defines a travel target, in % of ranged travel, for a corresponding set point, in % of ranged set point. Set point values range from -25% to 125%. Before modification, the custom characteristic is linear.

Figure 6. Travel Target Versus Ranged Set Point, for Various Input Characteristics (Zero Power Condition = Closed)

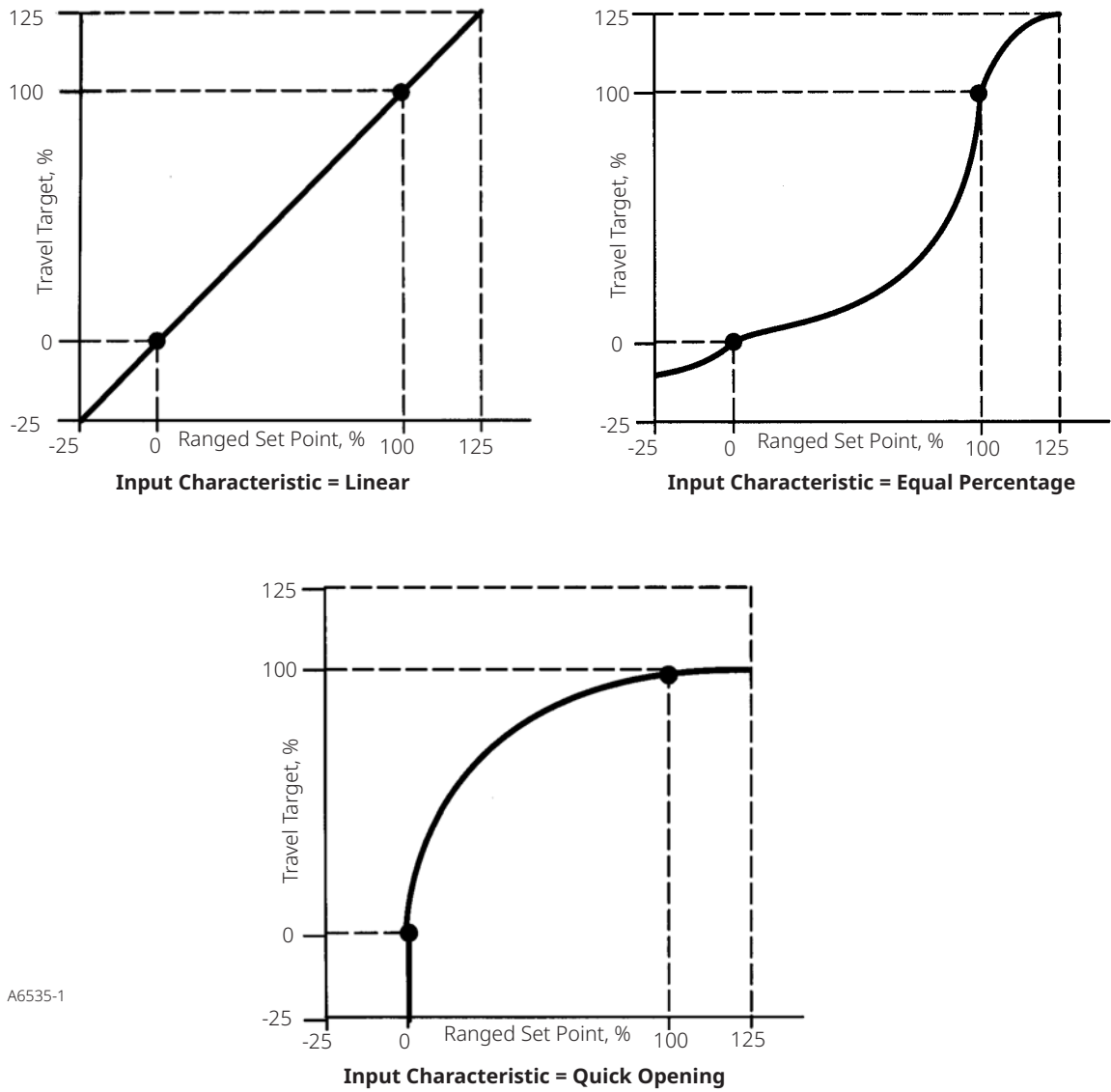

Valve

Handheld Communicator (DD)

Device Settings > Setup Overview > Valve

Identification

- Valve Manufacturer — Select the manufacturer of the valve.
- Valve Model — Select the model of the valve.
- Valve Serial Number — Enter the serial number for the valve in the application, up to 12 characters.
- Valve Size — Select the size of the valve.
- Valve Size Unit — Specify if the Valve Size is in inches, millimeters, centimeters or is unassigned.
- Valve Type — Specify type of valve body. Examples: globe, split body, double port, butterfly, ball, etc.
- ANSI Class — In accordance with ANSI B16.34-81.
- Valve Criticality — Enter the criticality of the valve.

Mechanics

- Dynamic Torque — Torque imposed on the valve closure member (disk, ball, plug, etc.) by the flowing process fluid.
- Breakout Torque — Enter the calculated valve torque required for seating and unseating of the valve closure member. Expressed in pounds of force x inches (lbf·in.), newtons x meters (N·m) or kilograms of force x meters (kgf·m). Used to compare the actual torque values.
- Friction/Torque Adder — Friction or torque that is not from the trim or packing.
- Friction/Torque Unit — Specify the units associated with the Friction and Torque parameters. The units can be: lbf, N, kgf, lbf·in, N·m, kgf·m or unassigned.
- Maximum Pressure — Specify maximum pressure of the valve.
- Maximum Pressure Unit — Specify if the units of the Maximum Pressure value are in psi, kPa, bar, kg/cm² or if it is unassigned.
- Maximum Temperature — Specify the maximum temperature of the valve.
- Maximum Temperature Unit — Specify if the units of the Maximum Temperature value are in degrees Fahrenheit, Celsius or if it is unassigned.

Construction

- Flow Direction — Specify the direction of the fluid forces on the closure member: Flow To Open or Flow To Close.
- Bonnet Type — Specify type of bonnet.
- Body/Bonnet Material — Specify body and bonnet material.
- Liner Material — Specify body liner material.
- Liner Inner Diameter — If there is a body liner, specify its inside diameter.
- Liner Inner Diameter Unit — Specify the units of the Liner Inner Diameter value.
- End Extension and Material — Specify end extensions, if any. Normally refers to sections of pipe or reducers welded to the body by the valve manufacturer.

- End Connection In — Specify end connection. May be integral or welded onto body.
- End Connection Out — Specify end connection. May be integral or welded onto body.
- Flange Face Finish — Specify flange face finish per ANSI B16.5-81 or special finish as required.
- Packing Type — Specify type of packing.
- Packing Material — Specify packing material.
- Isolation Valve Required — Specify whether an isolation valve is required.
- Is Valve Lube Required — Specify whether a lubricator is required.
- Lube Type — Specify lubricant.

Trim

- Trim Type — Specify type of trim.
- Trim Characteristic — Specify inherent flow characteristic of installed trim.
- Port Style — Specify the port style.
- Rated Travel — Specify the distance of movement of the closure member from the closed position to the rated full-open position. The rated full-open position is the maximum opening recommended by the manufacturers.
- Actual Travel — Specify the measured distance from the closed position to the full open position of the valve.
- Travel Unit — Specify the Rated Travel and Actual Travel in inches, centimeters or millimeters for sliding-stem valves or degrees for rotary valves.
- Rated FL — Specify rated FL of installed trim. Refer to ANSI/ISA-S75.01-1985.
- Rated XT — Specify rated XT of installed trim. Refer to ANSI/ISA-S75.01-1985.
- Rated CV — Specify rated CV of installed trim. Refer to ANSI/ISA-S75.01-1985.

Characteristics

- Unbalanced Area — Specify the valve's unbalanced area.
- Unbalanced Area Unit — Specify the Unbalanced Area in square inches, square centimeters or square millimeters.
- Port Diameter — Specify the port diameter.
- Port Diameter Unit — Specify the Port Diameter in inches, centimeters or millimeters.
- Stem Diameter — Specify the stem diameter.
- Stem Diameter Unit— Specify the Stem Diameter in inches, centimeters or millimeters.
- Seat Material — Specify seat material.
- Ball/Plug/Disk Material — Specify closure member, i.e., plug, ball or disk material as applicable.
- Stem Material — Specify stem material.
- Cage/Guide Material — Specify cage, bearing or guide material.
- Flow Tends To — Specify whether flow tends to OPEN or CLOSE a sliding-stem valve.
- Push Down To — Specify if the valve OPENS or CLOSES as the stem moves away from the bonnet.

Actuator

Handheld Communicator (DD)

Device Settings > Setup Overview > Actuator

Identification

- Actuator Manufacturer — Select the manufacturer of the actuator.
- Actuator Model — Select the model of the actuator.
- Actuator Style — Enter the actuator style; spring and diaphragm, piston double-acting without spring, piston single-acting with spring or piston double-acting with spring.

Mechanics

- Actuator Size — Specify the size of the actuator.
- Effective Area — Specify the effective area of the actuator diaphragm.
- Effective Area Unit — Specify the Effective Area of the actuator diaphragm in square inches, square centimeters or square millimeters.
- Lever Style — Specify the Lever Style as Unassigned, Pivot Link, Rack and Pinion or Scotch Yoke.
- Lever Arm Length — Specify the length of the connecting arm between the valve shaft and the actuator rod. For Rack and Pinion Actuator, this length is equal to the radius of the pinion.
- Lever Arm Unit — Specify the Lever Arm Length in inches, millimeters or centimeters.
- Spring Rate — The force of change per unit change in length of a spring. In diaphragm control valves, the spring rate is usually stated in pounds force per inch in compression.
- Spring Rate Unit — Specify the Spring Rate in pounds per inch (lb/in), newtons per millimeter (N/mm) or kilograms per millimeter (kg/mm).
- Array Type — Refer to Table 5 for the available array options. Choose the magnet assembly that matches the actuator travel range.

NOTE

As a general rule, do not use less than 60% of the magnet assembly travel range for full travel measurement. Performance will decrease as the assembly is increasingly subranged.

The linear magnet assemblies have a valid travel range indicated by arrows molded into the piece. This means that the Hall sensor (on the back of the DVC7K housing) has to remain within this range throughout the entire valve travel. The linear magnet assemblies are symmetrical. Either end may be up.

- Actuator Orientation — Enter orientation of actuator as viewed from valve inlet (ex. VERT. UP, VERT.DOWN or HORIZ). For rotary valves, specify right-hand (RH) or left-hand (LH).
- Handwheel Type — Enter the type and orientation of handwheel (manual override), if any.

Table 5. Actuator Array Options

Magnet Assembly	Travel Range		
	mm	in.	Degrees
SStem #7	4.2 to 7	0.17 to 0.28	---
SStem #19	8 to 19	0.32 to 0.75	---
SStem #25	20 to 25	0.76 to 1.00	---
SStem #38	26 to 38	1.01 to 1.50	---
SStem #50	39 to 50	1.51 to 2.00	---
SStem #110	51 to 110	2.01 to 4.125	---
SStem #210	110 to 210	4.125 to 8.25	---
SStem #1 Roller	> 210	> 8.25	60 to 90°
RShaft Window #1	---	---	60 to 90°
RShaft Window #2	---	---	60 to 90°
RShaft End Mount	---	---	60 to 90°

- Air Failure Valve — Specify if air failure valve (actuator air lock-up valve) is required.
- Air Failure Valve Set At — Specify what supply pressure the Air Failure Valve (actuator air lock-up valve) shuts.

Motion

- Air — Select "Opens" or "Closes" to indicate the effect of increasing air pressure on the valve travel.
- Travel Sensor Motion — "Counterclockwise/Toward Top of Instrument" indicates that there is a direct relationship between travel counts and drive (i.e., increasing drive results in increasing travel counts). "Clockwise/Toward Bottom of Instrument" indicates that there is an inverse relationship between travel counts and drive (i.e., increasing drive results in decreasing travel counts). Autocalibration and manual calibration will automatically set this variable. If this variable is set incorrectly, the instrument would not control.

⚠ WARNING

If you answer YES to the prompt for permission to move the valve when determining travel sensor motion, the instrument will move the valve through a significant portion of its travel range. To avoid personal injury and property damage caused by the release of process fluid or pressure, isolate the valve from the process and equalize pressure on both sides of the valve or bleed off the process fluid.

NOTE

Travel Sensor Motion in this instance refers to the motion of the magnet assembly. Note that the magnet assembly may be referred to as a magnetic array in user interface tools.

Pressure

- Maximum Available Supply Pressure — Specify limits of available air or hydraulic supply pressure.
- Nominal Available Supply Pressure — Enter the normal operating supply pressure.
- Minimum Available Supply Pressure — Specify limits of available air or hydraulic supply pressure.
- Maximum Allowable Pressure — Specify maximum pressure for which the actuator is designed.
- Minimum Required Pressure — Specify minimum pressure required to fully stroke the installed valve under specified conditions.
- Actuator Pressure Unit — Specify if the units associated with the pressure parameters are psi, kPa, bar, kg/cm² or are unassigned.

Bench Set

- Lower Bench Set — Bench Set is the pressure range required to fully stroke the actuator to the Rated Valve Travel without fluid forces acting on the valve. Lower Bench Set is the lower pressure value of the range.
- Upper Bench Set — Bench Set is the pressure range required to fully stroke the actuator to the Rated Valve Travel without fluid forces acting on the valve. Lower Bench Set is the lower pressure value of the range.

Service Conditions

Handheld Communicator (DD)

Device Settings > Setup Overview > Service Conditions

Fluid

- Service — Describe service of control valve and/or pipeline number.
- Fluid — Describe fluid flowing into valve and its state. Indicate corrosive or erosive service and the corrosive or erosive agents.
- Critical Pressure (P_c) — Specify thermodynamic critical pressure of the fluid.
- Critical Pressure Unit — Specify the Critical Pressure (P_c) unit.

Flow Rate

- Maximum Flow Rate — Enter the volumetric or mass flow rate at inlet for the maximum flow condition.
- Normal Flow Rate — Enter the volumetric or mass flow rate at inlet for the normal flow condition.
- Minimum Flow Rate — Enter the volumetric or mass flow rate at inlet for the minimum flow condition.
- Flow Rate Unit — Specify the units for the Maximum Flow - Flow Rate, Normal Flow - Flow Rate and Minimum Flow - Flow Rate variables.

Inlet Pressure

- Maximum Flow - Inlet Pressure — Specify the inlet pressure for the maximum flow condition.
- Normal Flow - Inlet Pressure — Specify the inlet pressure for the normal flow condition.
- Minimum Flow - Inlet Pressure — Specify the inlet pressure for the minimum flow condition.
- Inlet Pressure Shut-Off — Specify the inlet pressure for the shut off condition.
- Pressure Unit — Specify the units for Inlet Pressure variables or Outlet Pressure variables.

Outlet Pressure

- Maximum Flow - Outlet Pressure — Specify the outlet pressure for the maximum flow condition.
- Normal Flow - Outlet Pressure — Specify the outlet pressure for the normal flow condition.
- Minimum Flow - Outlet Pressure — Specify the outlet pressure for the minimum flow condition.
- Outlet Pressure Shut-Off — Specify the outlet pressure for the shut off condition.
- Pressure Unit — Specify the units for Inlet Pressure variables or Outlet Pressure variables.

Inlet Temperature

- Maximum Flow - Inlet Temperature — Specify the inlet temperature for the maximum flow condition.
- Normal Flow - Inlet Temperature — Specify the inlet temperature for the normal flow condition.
- Minimum Flow - Inlet Temperature — Specify the inlet temperature for the minimum flow condition.
- Inlet Temperature Shut-Off — Specify the inlet temperature for the shut-off condition. Must agree with state of fluid and its inlet pressure.
- Inlet Temperature Unit — Specify the units for Inlet Temperature variables.

Specific Gravity/Specific Weight/Molecular Weight

- Maximum Flow - SPG, SW or MW — Specify the specific weight (in lb/ft³ or kg/m³), specific gravity (no units) or molecular weight (g/mole) of fluid for the maximum flow condition.
- Normal Flow - SPG, SW or MW — Specify the specific weight (in lb/ft³ or kg/m³), specific gravity (no units) or molecular weight (g/mole) of fluid for the normal flow condition.
- Minimum Flow - SPG, SW or MW — Specify the specific weight (in lb/ft³ or kg/m³), specific gravity (no units) or molecular weight (g/mole) of fluid for the minimum flow condition.
- SPG, SW or MW Unit — Specify the units for Specific Weight, Specific Gravity or Molecular Weight. Enter the units for the service fluid as specific weight (lb/ft³ or kg/m³), Specific Gravity (no units) or as Molecular Weight (g/mole).

Viscosity/Specific Heats Ratio

- Maximum Flow - Viscosity/Specific Heats Ratio — Specify the viscosity in appropriate units for liquids or specific heats ratio for gases at maximum flow condition.
- Normal Flow - Viscosity/Specific Heats Ratio — Specify the viscosity in appropriate units for liquids or specific heats ratio for gases at normal flow condition.
- Minimum Flow - Viscosity/Specific Heats Ratio — Specify the viscosity in appropriate units for liquids or specific heats ratio for gases at minimum flow condition.
- Viscosity/Specific Heats Unit — Specify the viscosity in appropriate units for liquids or “none” for the specific heats ratio.

Vapor Pressure

- Maximum Flow - Vapor Pressure PV — Specify vapor (saturation) pressure at inlet temperature in absolute units at the maximum flow condition. Only required for liquid flow.
- Normal Flow - Vapor Pressure PV — Specify vapor (saturation) pressure at inlet temperature in absolute units at the normal flow condition. Only required for liquid flow.
- Minimum Flow - Vapor Pressure PV — Specify vapor (saturation) pressure at inlet temperature in absolute units at the minimum flow condition. Only required for liquid flow.
- Vapor Pressure (Pv) Unit — Specify the units for Vapor Pressure; Pv Max Flow, Vapor Pressure Pv Norm Flow and Vapor Pressure Pv Min Flow.

Required Cv

- Maximum Flow - Required Cv — Specify required Cv as calculated for the maximum flow condition per ANSI/ISA S75.01-1985. No additional safety factor should be included at this point.
- Normal Flow - Required Cv — Specify required Cv as calculated for the normal flow condition per ANSI/ISA S75.01-1985. No additional safety factor should be included at this point.
- Minimum Flow - Required Cv — Specify required Cv as calculated for the minimum flow condition per ANSI/ISA S75.01-1985. No additional safety factor should be included at this point.

Travel

- Maximum Flow - Travel — Enter travel of the valve in percent of rated travel calculated from required Cv, rated Cv of the valve, trim selected and characteristic at maximum flow condition. 0% is full closed, 100% is full open.
- Normal Flow - Travel — Enter travel of the valve in percent of rated travel calculated from required Cv, rated Cv of the valve, trim selected and characteristic at normal flow condition. 0% is full closed, 100% is full open.
- Minimum Flow - Travel — Enter travel of the valve in percent of rated travel calculated from required Cv, rated Cv of the valve, trim selected and characteristic at minimum flow condition. 0% is full closed, 100% is full open.

Sound Pressure Levels

- Maximum Flow
Allowable Sound Pressure Level — Specify laboratory-measured allowable sound pressure levels, normally in dBA as measured per ISAS75.07-1987 at maximum flow condition.
Predicted Sound Pressure Level — Specify laboratory-measured allowable and predicted sound pressure levels, both normally in dBA as measured per ISAS75.07-1987 at maximum flow condition.
- Normal Flow
Allowable Sound Pressure Level — Specify laboratory-measured allowable sound pressure levels, normally in dBA as measured per ISAS75.07-1987 at normal flow condition.
Predicted Sound Pressure Level — Specify laboratory-measured allowable and predicted sound pressure levels, both normally in dBA as measured per ISAS75.07-1987 at normal flow condition.
- Minimum Flow
Allowable Sound Pressure Level — Specify laboratory-measured allowable sound pressure levels, normally in dBA as measured per ISAS75.07-1987 at minimum flow condition.
Predicted Sound Pressure Level — Specify laboratory-measured allowable and predicted sound pressure levels, both normally in dBA as measured per ISAS75.07-1987 at minimum flow condition.
- Maximum Flow - Predicted Sound Pressure Level — Specify laboratory-measured predicted sound pressure levels, normally in dBA as measured per ISAS75.07-1987 at maximum flow condition.
- Normal Flow - Predicted Sound Pressure Level — Specify laboratory-measured predicted sound pressure levels, normally in dBA as measured per ISAS75.07-1987 at normal flow condition.
- Minimum Flow - Predicted Sound Pressure Level — Specify laboratory-measured predicted sound pressure levels, normally in dBA as measured per ISAS75.07-1987 at minimum flow condition.

Line

Handheld Communicator (DD)

Device Settings > Setup Overview > Line

Construction

- Pipe Line Size In — Specify size and schedule (or wall thickness if nonstandard) of pipe line into which valve is installed.
- Pipe Line Size Out — Specify size and schedule (or wall thickness if nonstandard) of pipe line into which valve is installed.
- Pipe Line Insulation — Specify pipe line insulation. This information is required for predicted sound pressure level calculations.

Switches / Airset / Test

Handheld Communicator (DD)

Device Settings > Setup Overview > Switches / Airset / Tests

Limit Switch / Valve Open

- Valve Open Switch Manufacturer — Specify the manufacturer of the switch.
- Valve Open Switch Model — Specify the model of the switch.
- Valve Open Switch Type — Specify the type of limit switch (Ex. Dry Contact, Mechanical, Proximity, Pneumatic).
- Valve Open Switch Contacts/Rating/Action — Specify electrical rating and number of contacts and action.

Limit Switch / Valve Closed

- Valve Closed Switch Manufacturer — Specify the manufacturer of the switch.
- Valve Closed Switch Model — Specify the model of the switch.
- Valve Closed Switch Type — Specify the type of limit switch (Ex. Dry Contact, Mechanical, Proximity, Pneumatic).
- Valve Closed Switch Contacts/Rating/Action — Specify electrical rating and number of contacts and action.

Airset

- Airset Manufacturer — Specify the manufacturer of the airset.
- Airset Model — Specify the model of the airset.
- Airset Filter — Specify whether a filter is required.
- Airset Gauge — Specify whether a pressure gauge is required.
- Airset Set Pressure — Specify output pressure setting.
- Airset Set Pressure Unit — Specify units of the Airset Set Pressure.

Tests

- Hydro Pressure Test — Specify pressure of hydrostatic test. Normally per ANSI B16.37-80 or API 6A-83.
- Hydro Pressure Unit — Specify the pressure units for the Hydro Pressure Test.
- ANSI/FCI Leakage Class — Specify leakage class per ANSI/FCI 70-2-76.
- Valve Assembly Diagnostic — Specify the Factory Signature Series Test performed.

Specials / Accessories

Handheld Communicator (DD)

Device Settings > Setup Overview > Specials / Accessories

Hazardous Location Classification

- NEC Class/Group/Div— Specify hazardous location classification per the National Electrical Code®, ANSI/NFPA 70-1987.

Boosters

- Volume Booster Type — Specify if there is a stand-alone relay that boosts or amplified the volume of air supplied to the actuator.
- Volume Booster Cv — Specify the Volume Booster Cv.

Releases

- Quick Release — Specify if there is a valve located in the piping between the instrument and the actuator that allows air to be quickly exhausted from the actuator.
- Quick Release Cv — Specify the Quick Release Cv.

Valves

- Solenoid Valve — Specify the Solenoid Valve type.
- Solenoid Valve Cv — Specify the Solenoid Valve Cv.
- Trip Valve — Specify the Trip Valve type.
- Trip Valve Fail State — Specify if the Trip Valve fail state is OPEN or CLOSED.
- Switch Valve — Specify the Switch Valve type.
- Switch Valve Fail State — Specify if the Switch Valve fail state is OPEN or CLOSED.

Miscellaneous

- Position Transmitter — Specify the Position Transmitter type.
- Wireless Adaptor — Specify the Wireless Adaptor type.

4.4 Tuning

Handheld Communicator (DD)	Device Settings > Tuning
Local User Interface (LUI)	Configure > Tuning > Manual Tuning

Travel Tuning

⚠ WARNING

Changes to the tuning set may cause the valve/actuator assembly to stroke. To avoid personal injury and property damage caused by moving parts, keep hands, tools and other objects away from the valve/actuator assembly.

- Travel Tuning Set

There are eleven tuning sets to choose from. Each tuning set provides a preselected value for the digital valve controller gain settings. Tuning set C provides the slowest response and M provides the fastest response.

Table 6 lists the proportional gain, velocity gain and minor loop feedback gain values for preselected tuning sets.

Table 6. Gain Values for Preselected Travel Tuning Sets

Tuning Set	Proportional Gain	Velocity Gain	Minor Loop Feedback Gain
C	4.4	3.0	35
D	4.8	3.0	35
E	5.5	3.0	35
F	6.2	3.1	35
G	7.2	3.6	34
H	8.4	4.2	31
I	9.7	4.85	27
J	11.3	5.65	23
K	13.1	6.0	18
L	15.5	6.0	12
M	18.0	6.0	12
X (Expert)	User Adjusted	User Adjusted	User Adjusted

In addition, you can specify Expert tuning and individually set the proportional gain, velocity gain and minor loop feedback gain.

NOTE

Use Expert tuning only if standard tuning has not achieved the desired results.

Table 7 provides tuning set selection guidelines for Fisher and Baumann actuators. These tuning sets are only recommended starting points. After you finish setting up and calibrating the instrument, you may have to select either a higher or lower tuning set to get the desired response. The default tuning set is H if no actuator is selected.

Table 7. Actuator Information for Initial Setup

Actuator Manufacturer	Actuator Model	Actuator Size	Actuator Style	Starting Tuning Set	Travel Sensor Motion ⁽²⁾ Relay A or C ⁽³⁾	
Fisher	585C and 585CR	25 50 60 68, 80 100, 130	Piston Dbl with or without Spring. See actuator instruction manual and nameplate.	E I J L M	User Specified	
	657	30, 30i 34, 34i, 40, 40i 45, 45i, 50, 50i 46, 46i, 60, 60i, 70, 70i and 80 to 100	Spring and Diaphragm	H K L M	Towards bottom of instrument	
	667	30, 30i 34, 34i, 40, 40i 45, 45i, 50, 50i 46, 46i, 60, 60i, 70, 70i, 76, 76i and 80 to 100	Spring and Diaphragm	H K L M	Towards top of instrument	
	1051 and 1052	20, 30 33 40 60, 70	Spring and Diaphragm (Window-mount)	H I K M	Towards bottom of instrument	
	1061	30 40 60 68, 80, 100, 130	Piston Dbl without Spring	J K L M	Depends upon pneumatic connections. See description for Travel Sensor Motion.	
	1066SR	20 27, 75	Piston Sgl with Spring	G L	Mounting Style	Travel Sensor Motion
					A	Towards bottom of instrument
					B	Towards top of instrument
					C	Towards top of instrument
		D	Towards bottom of instrument			
2052	1 2 3	Spring and Diaphragm (Window-mount)	H J M	Towards bottom of instrument		
3024C	30, 30E 34, 34E, 40, 40E 45, 45E	Spring and Diaphragm	E H K	For Po operating mode (air opens): Towards top of instrument For Ps operating mode (air closes): Towards bottom of instrument		
GX	225	Spring and Diaphragm	X ⁽¹⁾	Air to Open Towards top of instrument	Air to Close Towards bottom of instrument	
	750		K			
	1200		M			

- continued -

Table 7. Gain Values for Preselected Travel Tuning Sets (continued)

Actuator Manufacturer	Actuator Model	Actuator Size	Actuator Style	Starting Tuning Set	Travel Sensor Motion ⁽²⁾ Relay A or C ⁽³⁾
Baumann	Air to Extend	16	Spring and Diaphragm	C E H	Towards bottom of instrument
		32			Towards top of instrument
	Air to Retract	54			
	Rotary	10 25 54		E H J	Specify

NOTE: Refer to Table 5 for array (magnet assembly) information.

1. X = Expert Tuning. Proportional Gain = 4.2; Velocity Gain = 3.0; Minor Loop Feedback Gain = 18.0

2. Travel Sensor Motion in this instance refers to the motion of the magnet assembly.

3. Values shown are for Relay A and C. Reverse for Relay B.

- **Integral Deadzone** — A window around the Primary Setpoint in which integral action is disabled. The Dead Zone is configurable from 0% to 2%, corresponding to a symmetric window from 0% to +/-2% around the Primary Setpoint.

Integral Dead Zone is used to eliminate friction induced limit cycles around the Primary Setpoint when the integrator is active. This dead zone value is used during the Auto Calibration of Travel procedure even if the travel integral is disabled; in the case of Auto Calibration travel failures with piston actuators, this value should be set to 1%. Default value is 0.26%.

- **Integral Gain** — Travel Integral Gain is the ratio of the change in output to the change in input, based on the control action in which the output is proportional to the time integral of the input.
- **MLFB Gain** — the minor loop feedback gain for the travel control tuning set. Changing this parameter will also change the tuning set to Expert.
- **Travel Proportional Gain** — the proportional gain for the travel control tuning set. Changing this parameter will also change the tuning set to Expert.
- **Travel Velocity Gain** — the velocity gain for the travel control tuning set. Changing this parameter will also change the tuning set to Expert.

4.5 Inputs

Handheld Communicator (DD)	Device Settings > Input/Output > Inputs
-----------------------------------	---

Input Current Range

- **Upper Range Value** — The Upper Range Value should correspond to Travel Range High, if the Zero Power Condition is configured as closed. If the Zero Power Condition is configured as open, the Upper Range Value corresponds to Travel Range Low. See Figure 7.
- **Lower Range Value** — The Lower Range Value should correspond to Travel Range Low, if the Zero Power Condition is configured as closed. If the Zero Power Condition is configured as open, the Lower Range Value corresponds to Travel Range High. See Figure 7.

Figure 7. Calibrated Travel to Analog Input Relationship

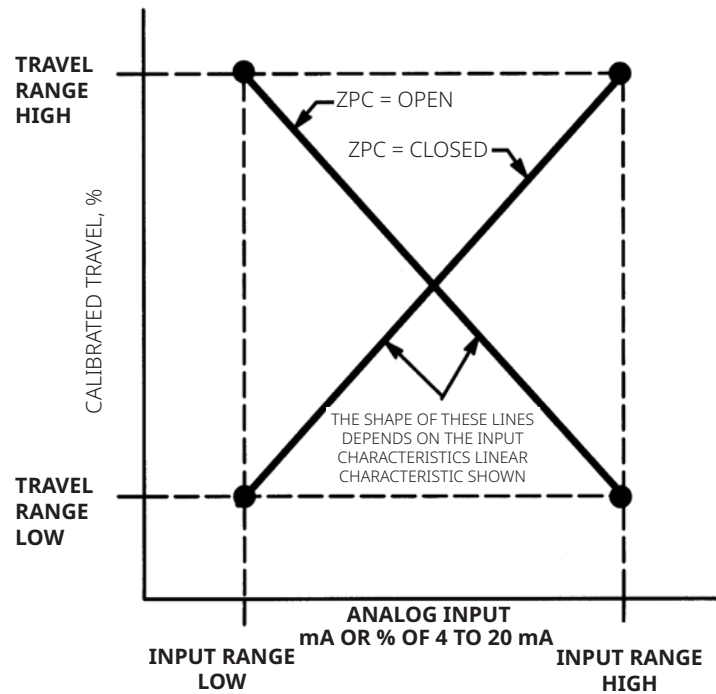

NOTE:
ZPC = ZERO POWER CONDITION

A6531-1

4.6 Outputs

Handheld Communicator (DD)	Device Settings > Input/Output > Outputs
Local User Interface (LUI)	Configure > Outputs

HART Variable Assignments

Instrument variables can be reported via four different HART variable assignments. The Primary Variable is always configured as Input Current. However, the remaining three variables have additional options as listed below.

NOTE

The HART Variable Assignments are not configurable with the Local User Interface.

NOTE

Write Protect must be disabled to configure the HART Variables.

Primary Variable (PV)	Input Current
Secondary Variable (SV)	Input Current, Travel, Setpoint (Default), Travel De-Characterized, Output A, Output B, Supply Differential Pressure, Temperature, Setpoint Pre-Characterized
Tertiary Variable (TV)	Input Current, Travel, Setpoint, Travel De-Characterized, Output A (Default), Output B, Supply, Differential Pressure, Temperature, Setpoint Pre-Characterized
Quaternary Variable (QV)	Input Current, Travel (Default), Setpoint, Travel De-Characterized, Output A, Output B, Supply, Differential Pressure, Temperature, Setpoint Pre-Characterized

Output Terminal Configuration

NOTE

These menu items are only available on units that have the optional 4 to 20 mA position transmitter and switches 1 and 2 hardware installed. For information on position transmitter/discrete switch wiring and configuration refer to the DVC7K-H Quick Start Guide, [D104766X012](#).

Position Transmitter

If the DVC7K device was purchased with I/O options, the device has an optional output circuit for a 4 to 20 position transmitter. The output circuits must be enabled with a user interface tool or the Local User Interface (LUI). Below are the configuration parameters for the position transmitter.

- **Function:** This configures the relationship between the valve travel and the position transmitter output signal. The position transmitter can have the following Functions: Disabled, 4 mA Open or 4 mA Closed.
- **Fail Signal:** If the position transmitter is enabled, select the Fail Signal as either: Hi (>22.5 mA) or Lo (<3.6 mA).

NOTE

On loss of loop power the position transmitter will transmit the Lo Fail Signal.

Switch 1 and Switch 2

If the DVC7K device was purchased with I/O options, the device has optional output circuits for two solid state dry contact switches. Switch 1 is a normally open circuit and Switch 2 is a normally closed circuit. The output circuits must be enabled with a user interface tool or the Local User Interface (LUI). Below are the configuration parameters for Switches 1 and 2.

- Function: Can be configured as Disabled, Limit Switch or Alert Switch.
 - If Limit Switch was selected, the following needs to be configured:
 - Action: Can be configured as Closed Above Trip or Closed Below Trip
 - Trip Point: Defines the threshold, in percent of travel, for the limit switch.If Alert Switch was selected, the following needs to be configured:
 - Alert Action: Determines the switch action when one of the configured alerts is active or inactive. The Alert Switches can have the following Alert Action: Alert Active or Alert Inactive.
 - Alert Source Enable: Defines which alerts activate or deactivate the switch based on the Alert Action.

NOTE

Alert Switches cannot be configured with the LUI.

4.7 Alert Setup

Handheld Communicator (DD)	Diagnostics > Alerts
Local User Interface (LUI)	Configure > Alert Setup

An alert is a notification that the instrument has detected a condition that has exceeded the alert conditions. Alerts that are enabled and active will be recorded in the instrument memory within the Alert Record (see Section 6). Some alerts are also defined in the HART Command 48 response structure which can be read by any HART communicating host system.

Alerts may be enabled or disabled when the instrument is Unprotected and its Instrument Mode is Automatic or Manual.

For a detailed explanation of the alerts and the recommended actions, refer to Section 6.

Section 5: Calibration

Calibration Overview

When a DVC7K digital valve controller is ordered as part of a control valve assembly, the factory mounts the digital valve controller on the actuator and connects the necessary tubing, then sets up and calibrates the controller.

For digital valve controllers that are ordered separately, recalibration of the analog input or pressure sensors generally is unnecessary. However, after mounting on an actuator, perform Guided Setup to configure and calibrate your device. For more detailed calibration information, refer to the following calibration procedures.

Handheld Communicator (DD)	Device Settings > Calibration
Local User Interface (LUI)	Configure > Calibration

NOTE

The Instrument Mode must be in Manual and Write Protect must be disabled before the instrument can be calibrated.

WARNING

During calibration, the valve will move full stroke. To avoid personal injury and property damage caused by the release of pressure or process fluid, isolate the valve from the process and equalize pressure on both sides of the valve or bleed off the process fluid.

5.1 Travel Calibration

Auto Calibration

1. Auto Calibration prompts you to remove Write Protection if enabled and then sets the Instrument Mode to Manual if in Automatic.
Auto Calibration establishes the limits of physical travel (i.e., the actual travel 0 and 100% positions). During this process, the valve will fully stroke from one travel extreme to the other. Auto Calibration also determines how far the relay beam swings to calibrate the sensitivity of the MLFB sensor. The relay and I/P biases are then set.
2. If the Instrument Mode was changed to Manual, you are prompted to return the Instrument Mode to Automatic after Auto Calibration is complete.
3. If Write Protection was disabled, you are prompted to re-enable the Write Protection.
4. Verify that the travel properly tracks the input signal.

NOTE

The Instrument Mode must be Automatic to track the input signal.

If the unit does not calibrate, refer to Table 8 for error messages and possible remedies.

Table 8. Auto Calibration Error Messages

Error Message	Possible Problem and Remedy
Error Low Power	The analog input signal to the instrument must be greater than 3.8 mA. Adjust the current output from the control system or the current source to provide at least 4.0 mA.
Error Timeout	The problem may be one of the following: 1. The tuning set selected is too low and the valve does not reach an end point in the allotted time. Select a higher tuning set (i.e., if tuning set is D, change to E). 2. Prior to receiving this message, did the instrument output go from zero to full supply? If not, verify instrument supply pressure by referring to the specifications in the appropriate actuator instruction manual. If supply pressure is correct, check instrument pneumatic components (I/P converter and relay). 3. The pressure sensors may need calibrating. The device is waiting for pressure readings below a certain threshold on the low end and if it is not reached, the device may timeout.
Error Failed Sensor	The travel sensor data is bad. Check that the magnet assembly is mounted correctly. If there is no problem with the mounting, then there is a problem with the travel sensor and the instrument will need to be replaced.
Error No Movement	Prior to receiving this message, did the instrument output go from zero to full supply? If not, verify instrument supply pressure by referring to the specifications in the appropriate actuator instruction manual. If supply pressure is correct, check instrument pneumatic components (I/P converter and relay). If the instrument output did go from zero to full supply prior to receiving this message, then verify proper mounting by referring to the appropriate mounting procedure in the Installation section and checking the magnet assembly for proper alignment. Additionally, check that the correct magnet assembly size was selected.

- continued -

Table 8. Auto Calibration Error Messages (continued)

Error Message	Possible Problem and Remedy
Error Invalid Endpoint	The device is traveling outside of the expected travel range. Travel Counts for Low or High Travel Counts are outside of the factory travel calibrated range. The problem may be one of the following: <ul style="list-style-type: none"> • The wrong magnet assembly size was selected. • The magnet assembly was not mounted correctly.
Error Memory Write	The analog input signal to the instrument is reading less than 3.8 mA. Adjust the current output from the control system or the current source to provide at least 4.0 mA.
Warning Default Relay Bias	The problem may be one of the following: <ol style="list-style-type: none"> 1. The tuning set selected is too low and the valve does not reach an end point in the allotted time. Select a higher tuning set (i.e., if tuning set is D, change to E). 2. The tuning set selected is too high, valve operation is unstable and does not stay at an end point for the allotted time. Select a lower tuning set (i.e., if tuning set is D, change to C). 3. Excessive valve friction was detected. The valve was unable to settle out. Check the mechanical assembly. 4. The Integral Deadzone is set too low and is unable to eliminate friction induced limit cycles around the setpoint when the integrator is active. Increase the Integral Deadzone value. <p>Note: Auto Calibration always uses the integrator to calibrate certain values even if the integrator is disabled during normal operation.</p>
Warning Default I/P Bias	The problem may be one of the following: <ol style="list-style-type: none"> 1. The tuning set selected is too low and the valve does not reach an end point in the allotted time. Select a higher tuning set (i.e., if tuning set is D, change to E). 2. The tuning set selected is too high, valve operation is unstable and does not stay at an end point for the allotted time. Select a lower tuning set (i.e., if tuning set is D, change to C). 3. Excessive valve friction was detected. The valve was unable to settle out. Check the mechanical assembly. 4. The Integral Deadzone is set too low and is unable to eliminate friction induced limit cycles around the setpoint when the integrator is active. Increase the Integral Deadzone value. <p>Note: Auto Calibration always uses the integrator to calibrate certain values even if the integrator is disabled during normal operation.</p>

Manual Calibration

1. Manual Calibration prompts you to remove Write Protection if enabled and then sets the Instrument Mode to Manual if in Automatic.
2. The digital valve controller will find the low drive endpoint.
3. When the valve is done moving, mark the low drive endpoint by selecting Accept.
4. The digital valve controller will then find the high drive endpoint.
5. When the valve is done moving, mark the high drive endpoint by selecting Accept.
6. The digital valve controller will then stroke the valve to mid travel to find the bias points.
7. When the valve is stable, select Accept.
8. The valve will find the relay bias and then the I/P bias to complete the calibration.
9. If the Instrument Mode was changed to Manual, you are prompted to return the Instrument Mode to Automatic.

10. If Write Protection was disabled, you are prompted to re-enable the Write Protection.
11. Verify that the travel properly tracks the input signal.

NOTE

The Instrument Mode must be Automatic to track the input signal.

If the unit does not calibrate, refer to Table 9 for error messages and possible remedies.

Table 9. Manual Calibration Error Messages

Error Message	Possible Problem and Remedy
Error Invalid Endpoint	The device is traveling outside of the expected travel range. Travel Counts for Low or High Travel Counts are outside of the factory travel calibrated range. The problem may be one of the following: <ol style="list-style-type: none"> 1. The wrong magnet assembly size was selected. 2. The magnet assembly was not mounted correctly.
Error No Movement	Prior to receiving this message, did the instrument output go from zero to full supply? If not, verify instrument supply pressure by referring to the specifications in the appropriate actuator instruction manual. If supply pressure is correct, check instrument pneumatic components (I/P converter and relay). If the instrument output did go from zero to full supply prior to receiving this message, then verify proper mounting by referring to the appropriate mounting procedure in the Installation section and checking the magnet assembly for proper alignment. If using a device description, there may be insufficient travel between marked end points. The problem may be one of the following: <ol style="list-style-type: none"> 1. The wrong magnet assembly size was selected. 2. The magnet assembly was not mounted correctly. 3. Not enough of the travel array is being used.
Error Invalid Bias	The problem may be one of the following: <ol style="list-style-type: none"> 1. The tuning set selected is too low and the valve does not reach an end point in the allotted time. Select a higher tuning set (i.e., if tuning set is D, change to E). 2. The tuning set selected is too high, valve operation is unstable and does not stay at an end point for the allotted time. Select a lower tuning set (i.e., if tuning set is D, change to C). 3. Excessive valve friction was detected. The valve was unable to settle out. Check the mechanical assembly.
Error Memory Write	The analog input signal to the instrument must be greater than 3.8 mA. Adjust the current output from the control system or the current source to provide at least 4.0 mA.
Error Timeout	The problem may be one of the following: <ol style="list-style-type: none"> 1. The tuning set selected is too low and the valve does not reach an end point in the allotted time. Select a higher tuning set (i.e., if tuning set is D, change to E). 2. If using the Local User Interface (LUI), the screen will time out after 10 minutes without user input. Be sure to promptly respond with the Local User Interface.

5.2 Sensor Calibration

Pressure Sensor Calibration

Handheld Communicator (DD)

Device Settings > Calibration > Pressure Sensor

NOTE

The pressure sensor is calibrated at the factory and should not require calibration.

NOTE

The input current must be more than 4.0 mA to run the pressure sensor calibration.

NOTE

The instrument cannot be locked out by the Local User Interface (LUI) or a primary or secondary master. Write Protect must be disabled and the Instrument Mode must be in Manual before the instrument can be calibrated.

1. Pressure Sensor Calibration prompts you to:
 - a. Unlock the instrument if locked out by a Primary or Secondary HART master.
 - b. Remove Write Protection if enabled.
 - c. Set the Instrument Mode to Manual if in Automatic.
2. You are then prompted to select which pressure sensor to calibrate.

NOTE

Only pressure sensors with a bad status will be listed.

- Pressure sensors for double-acting assemblies may include Supply Pressure, Output A or Output B.
- Pressure sensors for single-acting direct / reverse assemblies may include Supply Pressure or Output A.

3. Select Zero Only or Zero and Span (gauge required).

NOTE

Continue with the appropriate step below based on your selection and the sensor being calibrated.

Step 4: Zero Only, Supply Pressure sensor

Step 5: Zero Only, Output A sensor

Step 6: Zero Only, Output B sensor

Step 7: Zero and Span, Supply Pressure sensor

Step 8: Zero and Span, Output A sensor

Step 9: Zero and Span, Output B sensor

Continue with Step 10 once you have completed the appropriate sensor calibration.

NOTE

An external reference pressure gauge is required to run Zero and Span. The gauge should be capable of measuring maximum instrument supply pressure.

4. For Zero Only, Supply Pressure sensor calibration:
 - a. Adjust the supply regulator to remove the instrument supply pressure.
 - b. Select continue when the air is fully exhausted.
 - c. Go to step 10.
5. For Zero Only, Output A sensor calibration:
 - a. Wait until Output A pressure has fully exhausted.
 - b. Select continue.
 - c. Go to step 10.
6. For Zero Only, Output B sensor calibration:
 - a. Wait until Output B pressure has fully exhausted.
 - b. Select continue.
 - c. Go to step 10.
7. For Zero and Span, Supply Pressure sensor calibration:
 - a. Adjust the supply regulator to remove the instrument supply pressure.
 - b. Select continue when the air is fully exhausted.
 - c. Attach an external reference pressure gauge to the Supply Pressure port.
 - d. Select continue.
 - e. Adjust the supply regulator to the desired supply pressure.
 - f. Select continue.
 - g. Go to step 10.
8. For Zero and Span, Output A sensor calibration:
 - a. Wait until Output A pressure has fully exhausted.
 - b. Select continue.
 - c. Attach an external reference pressure gauge to the Output A port.
 - d. Select continue.
 - e. Wait until Output A has reached full regulated supply pressure.
 - f. Select continue.
 - g. Go to step 10.

9. For Zero and Span, Output B sensor calibration:
 - a. Wait until Output B pressure has fully exhausted.
 - b. Select continue.
 - c. Attach an external reference pressure gauge to the Output B port.
 - d. Select continue.
 - e. Wait until Output B has reached full regulated supply pressure.
 - f. Select continue.
 - g. Go to step 10.
10. If the Instrument Mode was changed to Manual, you are prompted to return the Instrument Mode to Automatic.
11. If Write Protection was disabled, you are prompted to re-enable the Write Protection.

Input Current Calibration

Handheld Communicator (DD)

Device Settings > Calibration > Input Current

NOTE

The DIP Switch must be set to 4 to 20 mA to run Input Current Calibration. The Input Current Calibration method will not run if the DIP Switch is set to 24 V DC.

NOTE

The Input Current sensor is calibrated at the factory and should not require calibration.

NOTE

The instrument cannot be locked out by a primary or secondary master. Write Protect must be disabled and the Instrument Mode must be in Manual before the instrument can be calibrated.

To calibrate the analog input sensor, connect a variable current source to the instrument LOOP+ and LOOP- terminals. The current source should be capable of generating an output of 4 to 20 mA. Follow the prompts on the handheld communicator display to calibrate the analog input sensor.

1. Input Current Calibration prompts you to:
 - a. Unlock the instrument if locked out by a Primary or Secondary HART master.
 - b. Remove Write Protection if enabled.
 - c. Set the Instrument Mode to Manual if in Automatic.

2. Adjust the current source to approximately 4 mA.
3. Select continue.
4. Use the increase and decrease selections until the displayed current matches the current source.
5. When the displayed current matches the current source, select Done to continue.
6. Adjust the current source to approximately 20 mA.
7. Select continue.
8. Use the increase and decrease selections until the displayed, current matches the current source.
9. When the displayed current matches the current source, select Done to continue.
10. If the Instrument Mode was changed to Manual, you are prompted to return the Instrument Mode to Automatic.
11. If Write Protection was disabled, you are prompted to re-enable the Write Protection.
12. Verify that the analog input displayed matches the current source.

NOTE

The Instrument Mode must be Automatic to track the input signal.

5.3 Relay Adjustment

Handheld Communicator (DD)

Device Settings > Calibration > Travel

Before beginning travel calibration, check the relay adjustment. Replace the digital valve controller cover when finished.

NOTE

Relay B and C are not user-adjustable.

Double-Acting Relay

The double-acting relay is designated by "Relay A" on a label affixed to the relay itself. For double-acting actuators, the valve must be near mid-travel to properly adjust the relay. The handheld communicator will automatically position the valve when Relay Adjust is selected.

Rotate the adjustment disc, shown in Figure 8, until the output pressure displayed on the handheld communicator is between 50 and 70% of supply pressure. This adjustment is very sensitive. Be sure to allow the pressure reading to stabilize before making another adjustment (stabilization may take up to 30 seconds or more for large actuators).

If the low bleed relay option has been ordered stabilization may take approximately two minutes longer than the standard relay.

Figure 8. Relay A Adjustment (Shroud Removed for Clarity)

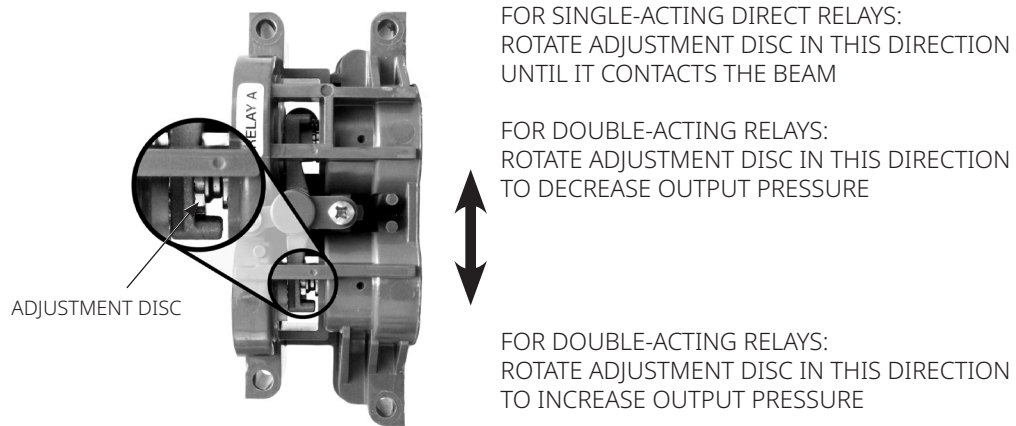

Relay A may also be adjusted for use in single-acting- direct applications. Rotate the adjustment disc as shown in Figure 8 for single-acting direct operation.

NOTE

Care should be taken during relay adjustment as the adjustment disc may disengage if rotated too far to the right.

Single-Acting Relays

Single-Acting Direct Relay

The single-acting direct relay is designated by "Relay C" on a label affixed to the relay itself. Relay C requires no adjustment.

Single-Acting Reverse Relay

The single-acting reverse relay is designated by "Relay B" on a label affixed to the relay itself. Relay B is calibrated at the factory and requires no further adjustment.

Section 6: Device Information, Diagnostics and Variables

6.1 Overview

Status and Primary Purpose Variables

Handheld Communicator (DD)	Overview
Local User Interface (LUI)	Overview > Primary Variables

The overview section provides basic information about the current state of the instrument and gives you access to the current values of the following:

Status/Primary Purpose Variable	Available in DD	Available in LUI
Alert Status	X	X
Communication Status	X	
Instrument Mode	X	
Input Current	X	X
Setpoint	X	X
Travel	X	X
Travel Deviation	X	X
Drive Signal	X	
Input Characteristic	X	
Supply Pressure	X	X
Output A Pressure	X	X ⁽¹⁾
Output B Pressure	X	X ⁽²⁾
1. Available only for Direct or Double-Acting assemblies. 2. Available only for Reverse or Double-Acting assemblies.		

Device Information

Handheld Communicator (DD)	Device Settings > Device Information
Local User Interface (LUI)	Overview > Device Information

Device Information provides details about the instrument construction including:

	Status/Primary Purpose Variable	Available in DD	Available in LUI
Identification	Tag	X	X
	Long Tag	X	X
	Polling Address	X	X
	Manufacturer	X	X
	Device Type	X	X
	Application Mode	X	X
	Device ID Unique number used to prevent the instrument from accepting commands intended for other instruments	X	X
	Control Tier		X
Serial Number	Work Order Serial Number	X	X
	Instrument Serial Number	X	X
	Valve Serial Number	X	X
Revisions	HART Protocol Revision	X	X
	Device Revision	X	X
	Hardware Revision	X	X
	Firmware Revision	X	X
DD Information	Device Type	X	
	DD Revision	X	
	Build Date	X	
	Build Number	X	
Blink Device	Blink Device (Squawk method) When run, the LED cycles through Green, Blue and Red. This method is used to locate or identify a device.	X	

Diagnostics

Alerts

Active Alerts

Handheld Communicator (DD)	Diagnostics > Alerts > Active Alerts
Local User Interface (LUI)	Service Tools > Active Alerts

In addition to on-board storage of alerts, the DVC7K can report active alerts via HART Command 48 - Read Additional Status. Active alerts will be displayed with their NE107 status and recommended action. The alerts will be listed in NE107 status priority. Refer to Table 10 for the NE107 status priority and Figure 9 for NE107 valve health indicators. If there are no alerts currently active, this display will be empty.

Refer to Table 10 for a summary of the default alert settings from the factory. Following is a detailed description of the meaning of each alert.

NOTE

Active alerts are cleared when the instrument is rebooted.

Table 10. NE107 Priority

NE107 Status	Priority	Description
Failure	1	Output signal is invalid due to malfunction in the field device or its peripherals.
Out of Specification	2	Deviations from the permissible ambient or process conditions determined by the device itself through self-monitoring or faults in the device itself indicate that the measuring uncertainty of sensors or deviations from the set value in actuators is probably greater than expected under operating conditions.
Function Check	3	Output signal temporarily invalid due to ongoing work on the device.
Maintenance Required	4	Although the output signal is valid, the wear reserve is nearly exhausted or a function will soon be restricted due to operational conditions.

Figure 9. NE107 Valve Health Indicators











SOLID (GREEN)			GOOD
BLINKING (GREEN)			MAINTENANCE REQUIRED
BLINKING (RED)			OUT OF SPECIFICATION
BLINKING (RED)			CHECK FUNCTION
SOLID (RED)			FAILED

Table 11. Default Alert Settings

Name	Default	Default NE107 Category
Non-Volatile Memory Defect	Enabled ⁽¹⁾	Failure
Volatile Memory Defect	Enabled ⁽¹⁾	Failure
Drive Signal	Enabled	Out of Specification
Alert Point	20 seconds	---
Drive Current	Enabled	Failure
Alert Point	10%	---
Deviation Time	2 seconds	---
Transmitter Open Circuit	Disabled	Function Check
Electronic Defect	Enabled ⁽¹⁾	Failure
Device Misconfigured	Enabled ⁽¹⁾	Function Check
Instrument Time is Approximate	Disabled	Maintenance Required
Calibration in Progress	Disabled	Function Check
Diagnostic in Progress	Disabled	Function Check
Temperature High	Enabled	Out of Specification
Threshold	80C / 176F	---
Temperature Low	Enabled	Out of Specification
Threshold	-40C / -40F	---
Loop Current Fixed	Enabled ⁽¹⁾	No Effect
Loop Current Saturated	Enabled ⁽¹⁾	Out of Specification
Instrument Mode	Disabled	Function Check
Supply Pressure High	Disabled	Out of Specification
Threshold	145 psi	---
Supply Pressure Low	Enabled	Out of Specification
Threshold	15 psi	---

- continued -

Table 11. Default Alert Settings (continued)

Name	Default	Default NE107 Category
Port A Overpressurized	Disabled	Failure
Threshold	146 psi	---
Travel Feedback Error	Enabled	Out of Specification
Travel Deviation	Enabled	Out of Specification
Threshold	5%	---
Time	5 seconds	---
Travel High	Disabled	No Effect
Alert Point	99%	---
Travel Low	Disabled	No Effect
Alert Point	1%	---
Travel Limit / Cutoff High	Disabled	No Effect
Type	Cutoff	---
Cutoff High	99.5%	---
Limit High	125%	---
Cutoff Rate High	0.0%/second	---
Travel Limit / Cutoff Low	Disabled	No Effect
Type	Cutoff	---
Cutoff Low	0.5%	---
Limit Low	-25%	---
Cutoff Rate Low	0.0%/second	---
Cycle Count High	Disabled	Maintenance Required
Alert Point	500,000	---
Travel Accumulator High	Disabled	Out of Specification
Alert Point	500,000	---
Travel Deadband Value	2%	---
Stroke Open Time ⁽²⁾	Disabled	Out of Specification
Stroke Open Time Baseline	NaN	---
Min. Stroke Open Time Threshold	0	---
Max. Stroke Open Time Threshold	60	---
Valve Open Threshold	98%	---
Stroke Close Time ⁽²⁾	Disabled	Out of Specification
Stroke Close Time Baseline	NaN	---
Min. Stroke Close Time Threshold	0	---
Max. Stroke Close Time Threshold	60	---
Valve Closed Threshold	2%	---

1. These default alert configurations cannot be changed.
2. Only applicable if Application Mode is On/Off.

History

Handheld Communicator (DD)

Diagnostics > Alerts > History

The DVC7K will store up to 1,000 alert events and will auto remove older logs when full using the First In First Out (FIFO) method.

Alert events occur when:

- Alerts are activated or deactivated (Refer to Table 11 for a full list of alerts)
- At instrument startup
- Alert simulation is entered or exited
- Auto calibration is entered or exited
- Manual calibration is entered or exited

Calibration in Progress is active when calibration is in progress. Wait for completion of the process or cancel calibration.

Cycle Count High is active if the Cycle Counter exceeds the Cycle Count High Alert Point. The Cycle Count records the number of times the travel changes direction when it is outside of the deadband. See Figure 11. This typically means that a valve component has reached a point where it should be inspected or replaced. To clear the alert, set the Cycle Counter to a value less than the alert point.

Device Misconfigured is active if the instrument identifies a configuration error that prevents the assembly from calibrating and/or working properly. The errors and their recommended actions are as follows:

- Travel Thresholds: check the cutoff and travel limit values.
- Pressure A, Pressure B and Supply Pressure: recalibrate the pressure sensors
- Loop: Recalibrate the analog input current.
- Alert Switch: check alert source mask of Switches 1 and 2
- Input Characterization: check characterization table

Diagnostics in Progress is active when a diagnostic test is in progress.

Drive Current is active when the drive current to the I/P converter is not flowing as expected. If this alert occurs, check the connection between the Sensor Assembly and the Front Cover Assembly. Try removing the I/P converter and reinstalling it. If the alert does not clear, replace the I/P converter or the Front Cover Assembly.

Drive Signal monitors the drive signal and calibrated travel. If one of the following conditions exists for more than the Drive Signal Deviation Time (default value is 20 seconds), the alert is set. Check the actuator and tubing pneumatics for air leaks. If no leaks, check the I/P and replace as needed.

For the case where Zero Power Condition is defined as closed:

Drive Signal < 10% and Calibrated Travel > 3%

Drive Signal > 90% and Calibrated Travel < 97%

For the case where Zero Power Condition is defined as open:

Drive Signal < 10% and Calibrated Travel < 97%

Drive Signal > 90% and Calibrated Travel > 3%

Electronic Defect is active if a sensor causes an electronic defect. To clear the alert, restart the instrument. If the alert persists, replace the instrument.

Instrument Mode is active if the Instrument Mode is not Automatic (AUTO).

Instrument Time is Approximate is active if the real time clock errors, power has been lost or the time was not set in the device. Figure out what caused the power cycle, try resetting the instrument time and/or install a new battery in the Front Cover Assembly.

Loop Current Fixed is active when the loop current is being held at a fixed value and is not responding to process variations. Check that the Instrument Mode is Automatic.

Loop Current Saturated is active when the loop current has reached its upper (or lower) endpoint limit and cannot increase (or decrease) any further. Check the loop current calibration.

Non-Volatile Memory (NVM) Defect is active if there is a failure associated with the Non-Volatile Memory (NVM) that is critical for instrument operation. To clear the alert, restart the instrument. If the alert persists, replace the Front Cover Assembly.

Port A Overpressurized applies to single-acting direct applications only. The alert is active if the output pressure from Port A of the DVC7K exceeds the configured alert point. Ensure the alert point is set below the actuator maximum casing pressure to protect the actuator from being over pressurized. Check the supply pressure regulator for damage and verify its pressure set point.

Stroke Close Time is active when the stroke time on close, which is the time it takes to travel from fully open to the Valve Closed Threshold, is faster than Min Stroke Close Time Threshold or is slower than the Max Stroke Close Time Threshold. If the stroke time is faster than the Min Stroke Close Time Threshold, verify the stem/shaft integrity, check the packing, and/or reduce process pressure. If the stroke time is slower than the Max Stroke Close Time Threshold, check for buildup and/or increased valve friction, check for air leaks and verify supply pressure.

Stroke Open Time is active when the stroke time on open, which is the time it takes to travel from fully closed to the Valve Open Threshold, is faster than Min Stroke Open Time Threshold or is slower than the Max Stroke Open Time Threshold. If the stroke time is faster than the Min Stroke Open Time Threshold, verify the stem/shaft integrity, check the packing and/or reduce process pressure. If the stroke time is slower than the Max Stroke Open Time Threshold, check for buildup and/or increased valve friction, check for air leaks and verify supply pressure.

Supply Pressure High is active if the supply pressure falls above the Supply Pressure High Alert point. Check the regulated supply pressure and make sure it is set appropriately.

Supply Pressure Low is active if the supply pressure falls below the Supply Pressure Low Alert Point. Check the supply pressure regulator. Confirm proper air supply and volume. Verify the Alert Point is not set too close to Actual Supply Pressure. The Alert Point should be at least 5 psi less than Actual Supply Pressure but could be more for larger valves.

Temperature High is active when the temperature falls above the Temperature High Alert Point. Check the instruments environment.

Temperature Low is active when the temperature falls below the Temperature Low Alert Point. Check the instruments environment.

Transmitter Open Circuit is active when the output transmitter has been enabled but no loop current is detected on the terminals. Check the transmitter terminals for loose wiring, that the analog wiring is connected at the AI card, and that power is applied.

Travel Accumulator High is active if the Travel Accumulator exceeds the Travel Accumulator Alert Point. The Travel Accumulator totalizes the travel of the valve when the deadband is exceeded. See Figure 10. This typically means that a valve component has reached a point where it should be inspected or replaced. To clear the alert, set the Travel Accumulator to a value less than the alert point.

Travel Deviation — If the difference between the Travel Target and the Travel exceeds the Travel Deviation Alert Point for more than the Travel Deviation Time, the Travel Deviation Alert is active. It remains active until the difference between the Travel Target and the Travel is less than the Travel Deviation Alert Point minus the Travel Alert Deadband. See Figure 11. The instrument is not doing what you have asked it to do within the time you asked it to do it. Check the valve friction, the supply air and/or the instrument tuning.

Travel Feedback Error is active if the sensed travel is outside the range of -25.0 to 125.0% of calibrated travel. If this alert is active, check the instrument mounting. Also, check that the electrical connection from the travel sensor is properly plugged into the Sensor Assembly from the Front Cover Assembly. After restarting the instrument, if the alert persists, troubleshoot the Sensor Assembly or Travel Sensor.

Travel High is active when the Travel exceeds the Travel High Alert Point. Once the alert is active, the alert will clear when the Travel falls below the Travel High Alert Point minus the Travel Alert Deadband. See Figure 10. Move the valve below the alert point and/or check the process loop.

Travel Low is active when the Travel is below the Travel Low Alert Point. Once the alert is active, the alert will clear when the Travel exceeds the Travel Low Alert Point plus the Travel Alert Deadband. See Figure 10. Move the valve above the alert point and/or check the process loop.

Travel Limit/Cutoff High is active if either the Travel Threshold High Action is Cutoff and Travel exceeds the Travel Cutoff High Point or Travel Threshold High Action is Limit and Travel exceeds the Travel Limit High Point. Move the valve below the limit or cutoff.

Travel Limit/Cutoff Low is active if either the Travel Threshold Low Action is Cutoff and Travel is below the Travel Cutoff Low Point or Travel Threshold Low Action is Limit and Travel falls below the Travel Limit Low Point. Move the valve above the limit or cutoff.

Volatile Memory Defect is active when there is a failure associated with the Volatile Memory. Restart the instrument. If the alert persists, replace the Front Cover Assembly.

Deadband Principle of Operation

The deadband is the percent (%) of ranged travel around a travel reference point where no change in alert status will occur. This prevents the alert from toggling on and off when operating near the alert point.

The Travel Deadband applies to the Travel Deviation Alert as well as the Travel High and Low Alerts. Figure 10 illustrates the principle behind setting and clearing a Travel High Alert. The alert is set when the travel exceeds the alert point and is cleared when it falls below the deadband.

Figure 10. Travel Alert Deadband

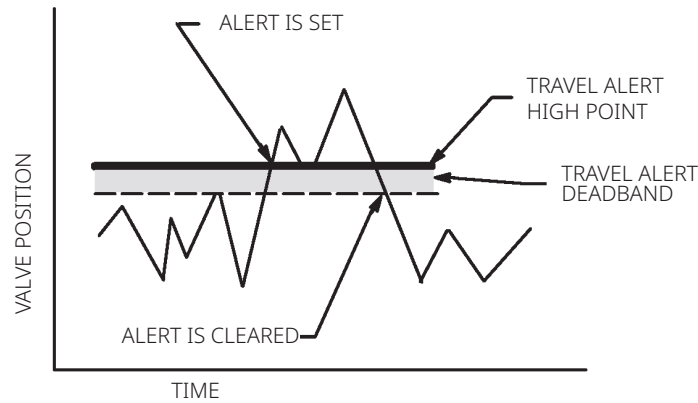

A6532

The Travel Deadband applies to both the Cycle Count High Alert and the Travel Accumulator High Alert. The deadband establishes a zone around a travel reference point. The travel reference point gets reestablished to the point of travel reversal that occurs outside of the deadband. The deadband must be exceeded before a change in travel direction will be counted as a cycle and the accumulated travel (up to the point of travel reversal) is added to the total accumulation. See Figure 11.

Figure 11. Cycle Counter and Travel Accumulator Deadband Example (Set at 10%)

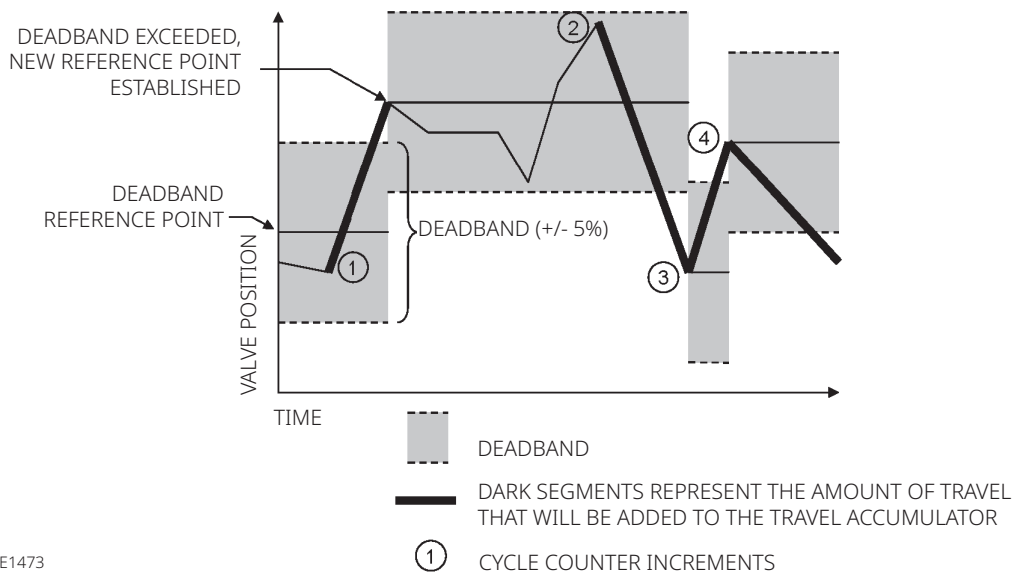

E1473

Stroke Valve

Handheld Communicator (DD)	Maintenance > Proof Test > Valve Diagnostics > Stroke Valve
Local User Interface (LUI)	Service Tools > Stroke Valve

NOTE

The Instrument Mode must be in Manual and Write Protect must be disabled before the instrument can be stroked.

1. Stroke Valve first prompts you to remove Write Protection if it is enabled and then sets the Instrument Mode to Manual if in Automatic.
2. The screen will show the current Setpoint and Travel. Select a target setpoint to stroke the valve.
3. Select Accept to apply the target setpoint.
 - a. Target Setpoint Options:
 - i. 100%
 - ii. 75%
 - iii. 50%
 - iv. 25%
 - v. 0%
 - vi. +2% (which strokes the valve 2% more than the current setpoint)
 - vii. -2% (which strokes the valve 2% less than the current setpoint)
4. Repeat step 2 as many times as needed. Once finished, select Back to return to the menus.
5. If the Instrument Mode was changed to Manual to perform Stroke Valve, you are prompted to return the Instrument Mode to Automatic.
6. If Write Protection was disabled, you are prompted to re-enable the Write Protection.

Variables

Handheld Communicator (DD)	Diagnostics > Variables
Local User Interface (LUI)	Service Tools > Variables

The Variables section provides current values of the instrument variables. Below is a list of the variables available for viewing:

- Mapped Variables (see Note 1 on the next page)
 - Primary Variable
 - Secondary Variable
 - Tertiary Variable
 - Quaternary Variable

- Status:
 - Status
If one or more alerts are active, the highest priority NE107 status will be displayed. Refer to Table 10 for details.
 - Write Protection (also provides a procedure to enable/disable)
 - Runtime
 - Powerups
 - Temperature
 - Travel
 - Input Current
 - Setpoint
 - Travel
 - Cycle Count
 - Pressure
 - Supply Pressure
 - Output A (see Notes 2 and 4 below)
 - Output B (see Notes 3 and 4 below)
 - Differential Pressure (see Note 3 below)
 - Stroke Information (see Note 5 below)
 - Stroke Open Baseline
 - Stroke Open Time
 - Stroke Closed Baseline
 - Stroke Closed Time
 - Configuration
 - Setpoint Source
 - Application Mode
 - Zero Power Condition
 - Restart Latch Status
 - Restart Latch Configuration
 - Relay Type
 - Outputs (see note 6 below)
 - Switch 1 Status
 - Switch 2 Status
-

NOTES

1. Not available in the LUI.
 2. Single-Acting Direct Assemblies only.
 3. Single-Acting Reverse Assemblies only.
 4. Double-Acting Assemblies only.
 5. On/Off Application Modes only.
 6. I/O Options Package only.
-

Section 7: Maintenance and Troubleshooting

The DVC7K digital valve controller enclosure is rated Type 4X and IP66, therefore, periodic cleaning of internal components is not required. If the DVC7K is installed in an area where the exterior surfaces tend to get heavily coated or layered with industrial or atmospheric contaminants, it is recommended that the vent be periodically removed and inspected to ensure there is no partial or full obstruction. If the vent appears to be partially or fully obstructed, it must be cleaned or replaced. Clean the vent as described in the Cleaning the Vent procedure.

NOTICE

Ensure that the housing vent opening is open and free of debris to prevent pressure buildup under the cover that could damage the DVC7K.

WARNING

To avoid static discharge from the enclosure when flammable gases or dust are present, do not rub or clean with solvents. To do so could result in a spark that may cause the flammable gases or dust to explode, resulting in personal injury or property damage. Clean with a mild detergent and water only.

WARNING

Avoid personal injury or property damage from sudden release of process pressure or bursting of parts. Before performing any maintenance procedures on the DVC7K digital valve controller:

- **Always wear protective clothing, gloves and eyewear.**
- **Do not remove the actuator from the valve while the valve is still pressurized.**
- **Disconnect any operating lines providing air pressure, electric power or a control signal to the actuator. Be sure the actuator cannot suddenly open or close the valve.**
- **Use bypass valves or completely shut off the process to isolate the valve from process pressure. Relieve process pressure from both sides of the valve.**
- **Use lock-out procedures to be sure that the above measures stay in effect while you work on the equipment.**
- **Check with your process or safety engineer for any additional measures that must be taken to protect against process media.**
- **Vent the pneumatic actuator loading pressure and relieve any actuator spring precompression so the actuator is not applying force to the valve stem; this will allow for the safe removal of the stem connector.**

⚠ WARNING

To avoid personal injury or property damage in Hazardous Area applications:

- Do not attempt to repair any product sealing surfaces.
- Certified blanking elements must be installed in all unused conduit entries.

⚠ WARNING

When using natural gas as the supply medium, or for explosion proof applications, the following warnings also apply:

- Remove electrical power before removing the housing cap. Personal injury or property damage from fire or explosion may result if power is not disconnected before removing the cap.
- Remove electrical power before disconnecting any of the pneumatic connections.
- When disconnecting any of the pneumatic connections or any pressure retaining part, natural gas will seep from the unit and any connected equipment into the surrounding atmosphere. Personal injury or property damage may result from fire or explosion if natural gas is used as the supply medium and appropriate preventive measures are not taken. Preventive measures may include, but are not limited to, one or more of the following: ensuring adequate ventilation and the removal of any ignition sources.
- Ensure that the cover is correctly installed before putting this unit back into service. Failure to do so could result in personal injury or property damage from fire or explosion.

⚠ WARNING

When replacing components, use only components specified by the factory. Always use proper component replacement techniques, as presented in this manual. Improper techniques or component selection may invalidate the approvals and the product specifications, as indicated in Table 1. It may also impair operations and the intended function of the device and could cause personal injury and property damage.

Because of the diagnostic capability of the DVC7K, predictive maintenance is available through the use of the Local User Interface or Handheld Communicator (DD). Using the digital valve controller, valve and instrument maintenance can be enhanced, thus avoiding unnecessary maintenance.

7.1 Removing the Magnetic Feedback Array Assembly

To remove the Magnet Feedback Array Assembly from the actuator stem, perform the following basic steps.

1. Make sure that the valve is isolated from the process.
2. Open the front cover.
3. Turn the lock screw counterclockwise to unlock the cap so that the cap can be unscrewed from the terminal box.
4. After removing the cap, note the location of field wiring connections and disconnect the field wiring from the terminal box.
5. Shut off the instrument air supply.
6. Disconnect the pneumatic tubing and remove the digital valve controller from the actuator.
7. Remove the screws holding the Magnet Feedback Array Assembly to the connector arm.

When replacing the instrument, be sure to follow the mounting guidelines in the quick start guide (D104766X012). Setup and calibrate the instrument prior to returning to service.

7.2 Component Replacement

The DVC7K contains the following components: front cover assembly, I/P converter, pneumatic relay, terminal box, vent and optional gauge block. If problems occur, these components may be removed from the digital valve controller and replaced with new components.

When replacing any of the components of the digital valve controller, the maintenance should be performed in an instrument shop whenever possible. Make sure that the electrical wiring and pneumatic tubing is disconnected prior to disassembling the instrument.

Tools Required

Table 12 lists the tools required for maintaining the DVC7K digital valve controller.

Table 12. Tools Required

Name	Default	Component
Phillips Screwdriver	#2	Front Cover Assembly Screws, Relay Screws, Terminal Box Ground Screws, Terminal Box Cover Lock Screw, Vent Screws and Module Base Assembly Screws
Phillips Screwdriver	#1	Terminal Box Center Screw and Sensor Assembly Kit Screws
Flathead Screwdriver	3.5 mm / 1/8 in.	Terminal Box Cage Clamps and Battery Removal
Allen Wrench	Metric Construction: 10 mm Imperial Construction: 3/8 in.	Terminal Box Electrical Pipe Plugs
Allen Wrench	Metric Construction: 7 mm Imperial Construction: 1/4 in.	Pneumatic Pipe Plugs

- continued -

Table 12. Tools Required (continued)

Name	Default	Component
Allen Wrench	5 mm	Integral Mount Pneumatic Pipe Plug
Hex Key	2.5 mm	I/P Converter Screws
Hex Key	3/16 in.	Gauge Block Screws
Socket	27 mm / 1-1/16 in.	Gauge Block Gauges
Pliers	---	E-Clip Removal

I/P Converter

NOTICE

Exercise care when performing maintenance on the digital valve controller. In order to maintain accuracy specifications, do not strike or drop the I/P converter during component replacement.

The I/P Converter is located between the Terminal Box and the Relay.

Figure 12. I/P Converter Location



NOTE

After I/P Converter component replacement, calibrate the digital valve controller to maintain accuracy specifications.

Removing the I/P Converter

1. Open the front cover, if not already opened.
2. Refer to Figure 13. Using a 2.5 mm hex socket wrench, remove the four socket-head screws that attach the shroud and I/P converter to the module base.
3. Remove the shroud and finger protector.
4. Pull the I/P converter straight out of the module base. Be careful not to damage the two electrical leads that come out of the base of the I/P converter.
5. Refer to Figure 13. Ensure that the O-ring and screen stay in the module base and do not come out with the I/P converter.

Replacing the I/P Converter

1. Refer to Figure 13. Inspect the condition of the O-ring and screen in the module base and replace them if necessary.
2. Ensure the two boots, shown in Figure 13, are properly installed on the electrical leads.

Figure 13. I/P Converter

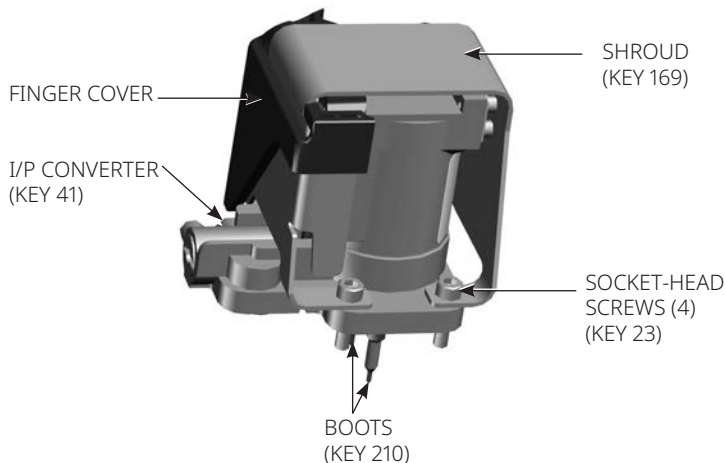

3. Install the I/P converter straight into the module base, taking care that the two electrical leads feed into the guides in the Sensor Assembly.

NOTE

The guides in the Sensor Assembly route the leads to the Front Cover Assembly.

4. Install the shroud over the I/P converter.
5. Install the four socket-head screws and evenly tighten them in a crisscross pattern to a final torque of 1.6 N•m / 14 lbf•in.
6. Attach the finger protector to the I/P shroud.
7. After replacing the I/P converter, calibrate travel or perform touch-up calibration to maintain accuracy specifications.

Replacing the I/P Filter

A screen in the supply port beneath the I/P converter serves as a secondary filter for the supply medium. To replace this filter, perform the following procedure:

1. Remove the I/P converter, shroud and finger protector as described in the Removing the I/P Converter procedure.
2. Remove the screen from the supply port.
3. Install a new screen in the supply port as shown in Figure 14.

Figure 14. I/P Filter Location

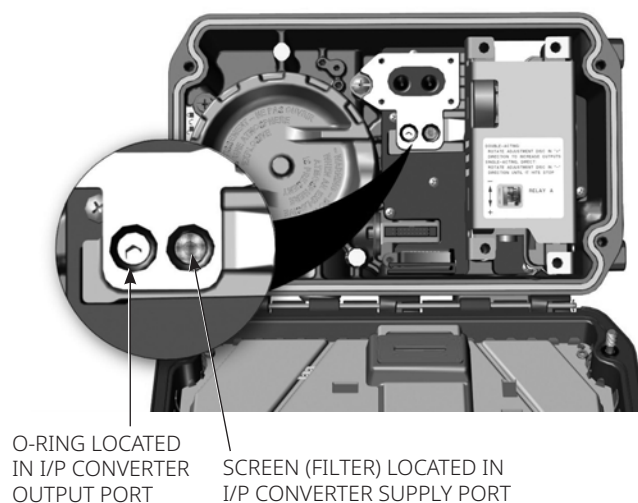

4. Inspect the O-ring in the I/P output port and replace if necessary.
5. Reinstall the I/P converter, shroud and finger protector as described in the Replacing the I/P Converter procedure.

Front Cover Assembly

The Front Cover Assembly is located on the front of the instrument.

NOTE

If the Front Cover Assembly is replaced, calibrate and configure the digital valve controller to maintain accuracy specifications.

Removing the Front Cover Assembly

1. Unscrew the four Front Cover Assembly screws.
2. Unplug the Front Cover Assembly's Ribbon Cable from the terminal box ribbon cable connection, see Figure 15 for cable location.

Figure 15. Sensor Board Ribbon Cable Connections

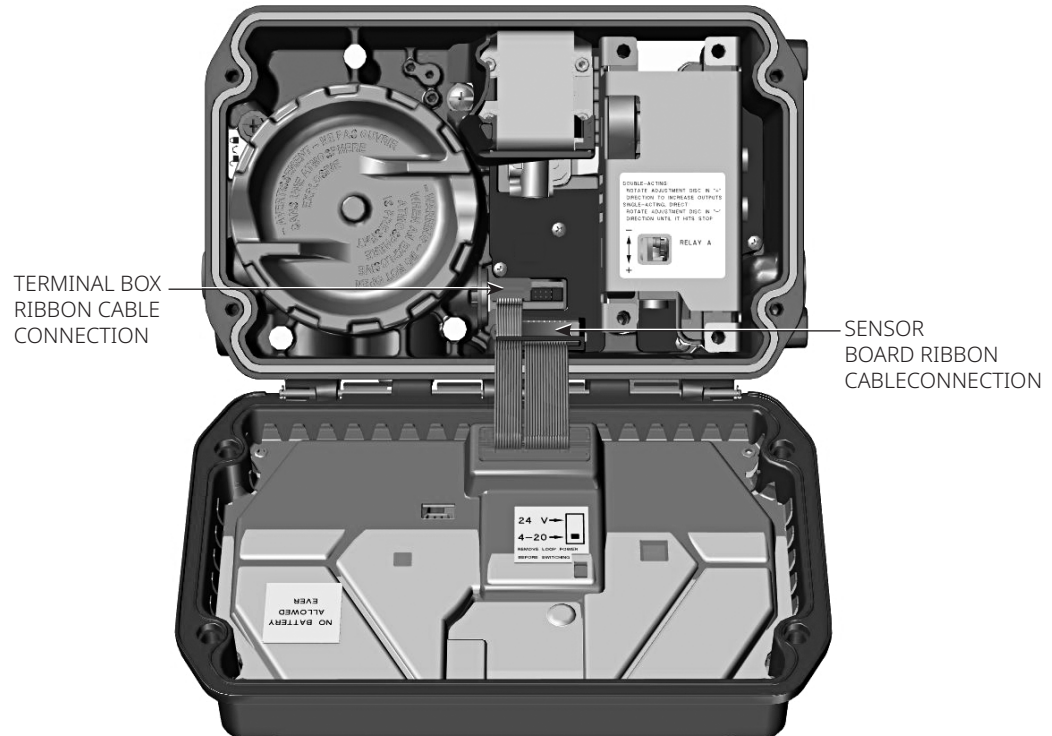

3. Unscrew the bottom left most screw on the sensor board.
4. Unplug the Front Cover Assembly's Ribbon Cable from the Sensor Board ribbon cable connection (see Figure 15).
5. Remove the E-ring (location shown in Figure 16) with the slip joint pliers.
6. Remove the hinge pin.

Figure 16. E-ring and Hinge Pin Location

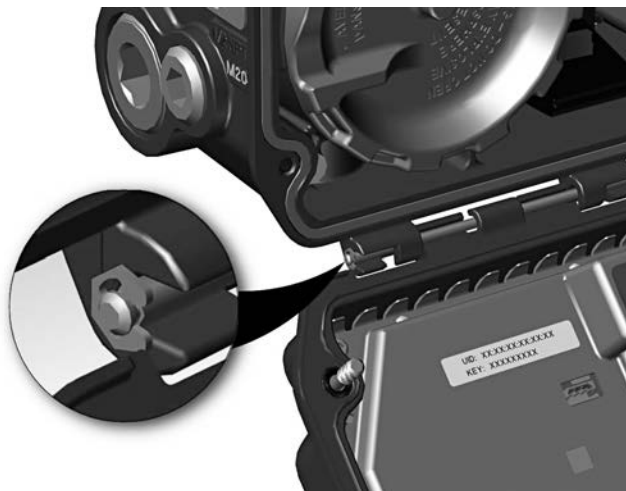

Replacing the Front Cover Assembly and Setting the DIP Switch

1. Remove the Front Cover Assembly, if not already removed.

NOTE

Refer to the Removing the Front Cover Assembly procedure.

2. Align the new Front Cover Assembly with the Housing and slide the hinge pin through the opening.
3. Attach the E-ring to the end of the hinge pin.
4. Attach the Sensor Board Ribbon Cable.
5. Screw in the bottom left most screw on the sensor board.
6. Attach the Terminal Box Ribbon Cable.
7. Set the DIP switch on the Front Cover Assembly (Figure 17) according to Table 13.

Table 13. DIP Switch Configuration⁽¹⁾

Operational Mode	DIP Switch Position
4 to 20 mA Point-to-Point Loop	DOWN
24 V DC Multi-Drop Loop ⁽²⁾	UP

1. Refer to Figure 17 for switch location.
2. Units with the I/O options can only be configured to 4 to 20 mA.

Figure 17. Printed Circuit Board (PCB) Connections and Settings

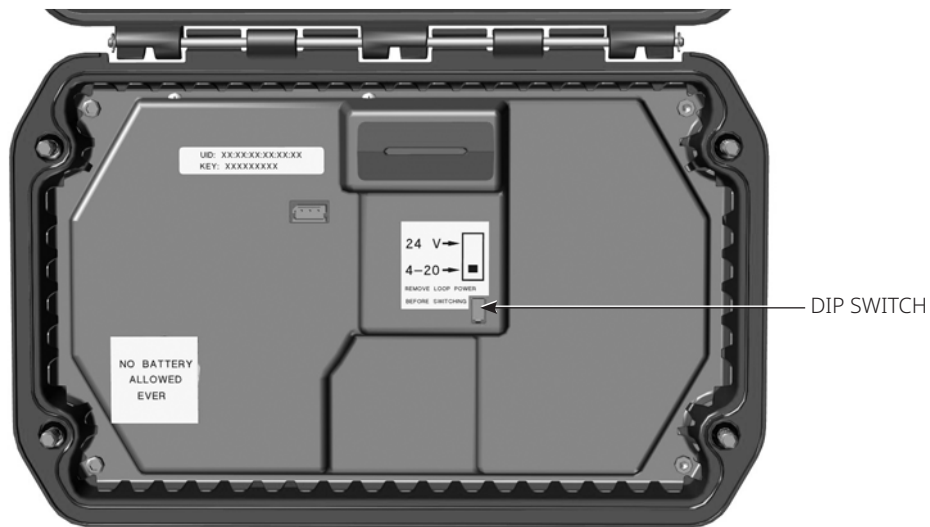

8. Ensure the seal is in place (Figure 18) and reattach the Front Cover Assembly. Tighten the four screws in a crisscross pattern.

Figure 18. Seal Location

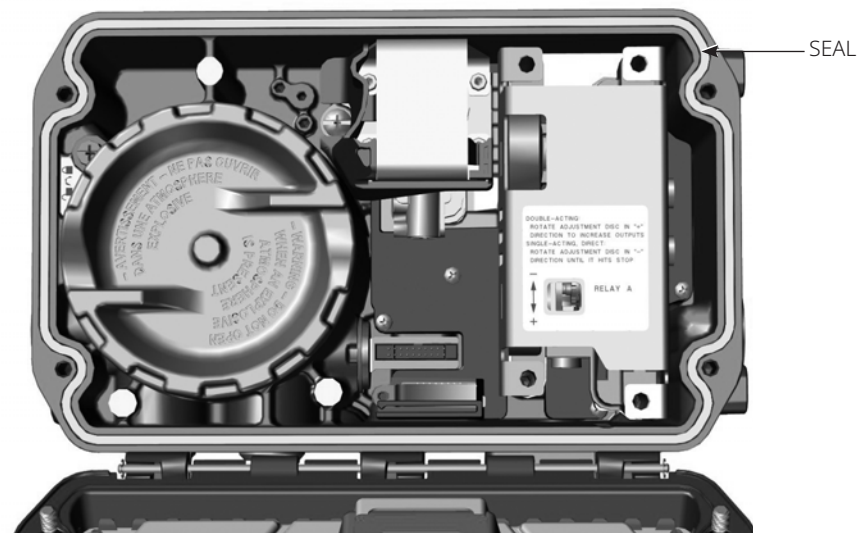

9. Setup and calibrate the digital valve controller.

Replacing the Battery Backup

⚠ WARNING

Use only Fisher battery, part number GK03960X012.
The Battery is not a standard, off the shelf battery. Use of a non-approved battery will void your Hazardous Area Approvals. Use only genuine Fisher replacement parts. Components that are not supplied by Emerson should not, under any circumstances, be used in any Fisher instrument. Use of components not supplied by Emerson may void your warranty, might adversely affect the performance of the instrument and could cause personal injury and property damage.

NOTE

To ensure optimal performance of the battery backup, we recommend replacing the battery every three years if in temperatures above 60 °C / 140 °F or every six years if at ambient room temperature, including time spent in inventory. Properly dispose of used lithium coin battery according to applicable federal, state and local laws and regulations.

NOTE

A battery is not included in Extreme Temperature units because the batteries are only rated down to -40 °C / -40 °F.

1. Open the front cover, if not already opened.
2. Remove the sticker covering the battery.

Figure 19. Battery Location

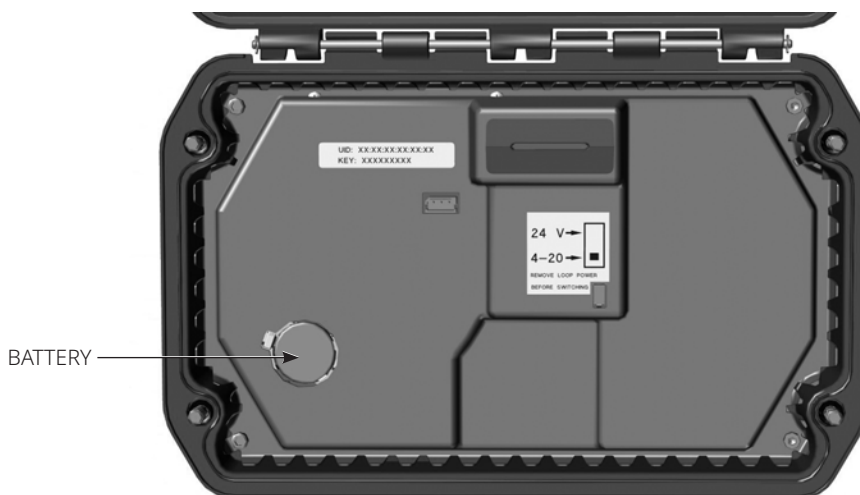

NOTE:
BATTERY WILL BE COVERED BY A STICKER.

3. Align the flathead screwdriver with the rectangular notch and insert the flathead screwdriver under the battery.
4. Hold the battery with one of your fingers and hinge up the screwdriver to remove the battery from the Front Cover Assembly.

NOTE

Ensure you have hold of the battery with one of your fingers when removing it to prevent the battery from falling under the metal cover shield.

5. Angle the new battery under the two metal clips and push to insert into the Front Cover Assembly.
6. Cover the battery hold with the sticker.

Pneumatic Relay

The pneumatic relay is located on the right side of the module base, as shown in Figure 20.

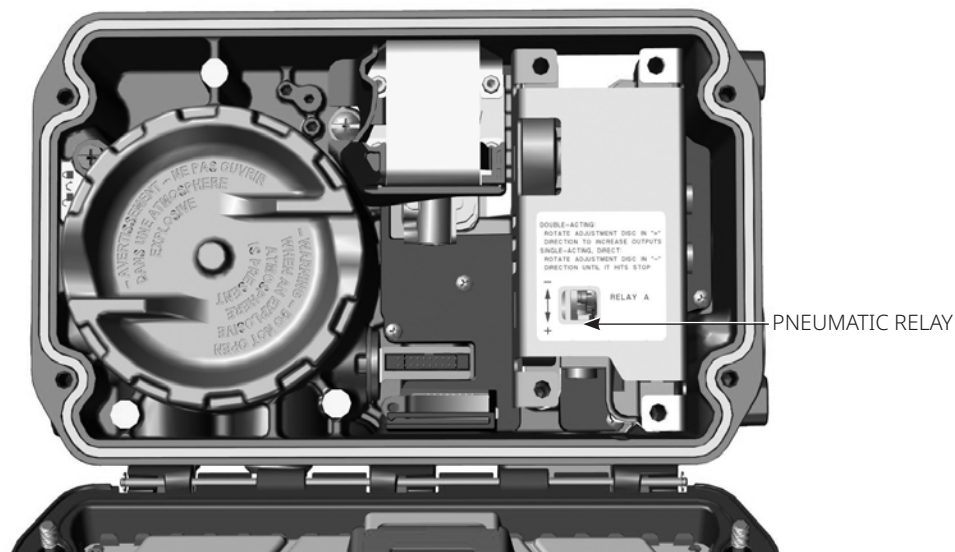
Figure 20. Pneumatic Relay Location

Removing the Pneumatic Relay

1. Open the front cover, if not already opened.
2. Loosen the four screws that attach the relay to the module base.
3. Remove the relay.

Replacing the Pneumatic Relay

1. Open the front cover, if not already opened.
2. Visually inspect the holes in the module base to ensure they are clean and free of obstructions.

NOTE

If cleaning is necessary, do not enlarge the holes.

3. Ensure the relay seal is installed at the bottom of the relay as shown in Figure 21.

Figure 21. Pneumatic Relay Assembly

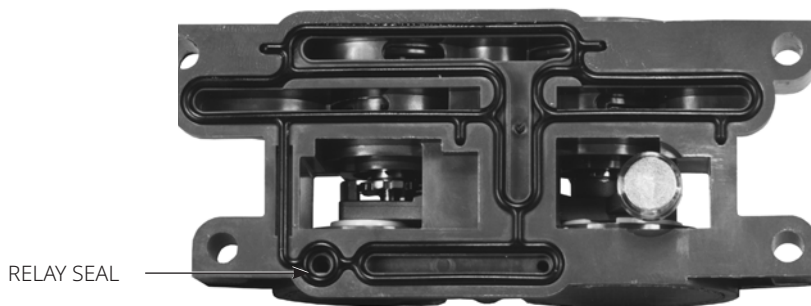

W8074

-
4. Position the relay (with shroud) on the module base.
 5. Use the four longer screws from the Relay Assembly kit; tighten in a crisscross pattern to a final torque of 2 N•m / 20.7 lbf•in.
 6. Using the Local User Interface (LUI) or handheld communicator (DD), verify that the value for Relay Type parameter matches the relay type installed.
 7. After replacing the relay and verifying the relay type, calibrate travel or perform touch-up calibration to maintain accuracy specifications.

Terminal Box

The terminal box is located within the housing as shown in Figure 22 and contains the terminal strip assembly for field wiring connections.

Figure 22. Terminal Box Location

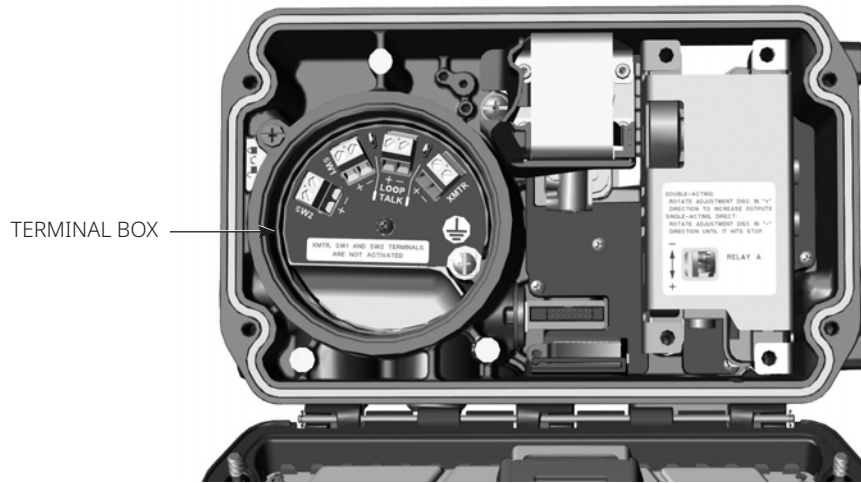

Removing the Terminal Box

⚠ WARNING

To avoid personal injury or property damage caused by fire or explosion, remove power to the instrument before removing the terminal box cover in an area which contains a potentially explosive atmosphere or has been classified as hazardous.

1. Open the front cover, if not already opened.
2. Turn the lock screw counterclockwise to unlock the cap so that the cap can be unscrewed from the terminal box.
3. After removing the cap note the location of field wiring connections and disconnect the field wiring from the terminal box.
4. Unscrew the center and ground screws.
5. Pull the terminal cup and label plate straight out of the housing.

Replacing the Terminal Box

1. Open the front cover, if not already opened.

NOTICE

This is a blind assembly. Install gently to avoid damage to the electronics assembly.

2. Align the black alignment pins and position the terminal cup so that the holes for the screws in the terminal cup align with the threaded holes in the housing.
3. Insert the terminal cup into the housing.
4. Place the label plate over the terminal cup.

5. Install the center and ground screws.
6. Reconnect the field wiring as noted in Step 3 in the Removing the Terminal Box procedure.
7. Apply lithium grease to the external threads on the terminal box cap.
8. Install the lock screw by turning it counterclockwise.
9. Screw the cap onto the terminal box until no gap remains.
10. Lock the lock screw by turning it clockwise into the cap and engaging the lock screw.

Vent

The Vent is located on the bottom right of the instrument (see Figure 23).

Figure 23. Vent



Cleaning the Vent

See Figure 24.

1. Remove the vent by unscrewing the two screws and removing the O-ring.
2. Carefully disassemble the vent.

NOTE

There are three parts to the vent, two vent housing components and a filter.

3. Clean each component with a mild water/detergent solution.

4. Allow the components to dry before reinstalling.
5. Reassemble the vent by inserting the filter and umbrella valve between the two vent housing components as shown in Figure 24.
6. Insert the O-ring into the Main Housing Assembly.
7. Align the Vent so that the hardware holes are aligned.
8. Insert and tighten the two screws to 1.3 N•m / 11.5 in•lbs to secure the Vent to the Main Housing Assembly.

Replacing the Vent

1. Remove the vent by unscrewing the two screws and removing the O-ring.
2. Insert the new O-ring from the Vent Parts Kit.
3. Align the Vent so that the hardware holes are aligned.
4. Insert and tighten the two screws to 1.3 N•m / 11.5 in•lbs to secure the Vent to the Main Housing Assembly.

Replacing the Pipe-Away Vent

See Figure 25.

1. Remove the Pipe-Away Vent by unscrewing the two screws and removing the O-ring.
2. Insert the new O-ring from the Pipe-Away Vent Connection Assembly Kit.
3. Align the Pipe-Away Vent so that the hardware holes are aligned; apply thread sealant to lubricate and seal the vent connection.
4. Insert and tighten the two screws to 1.3 N•m / 11.5 in•lbs to secure the Vent to the Main Housing Assembly.

Figure 24. Vent Assembly

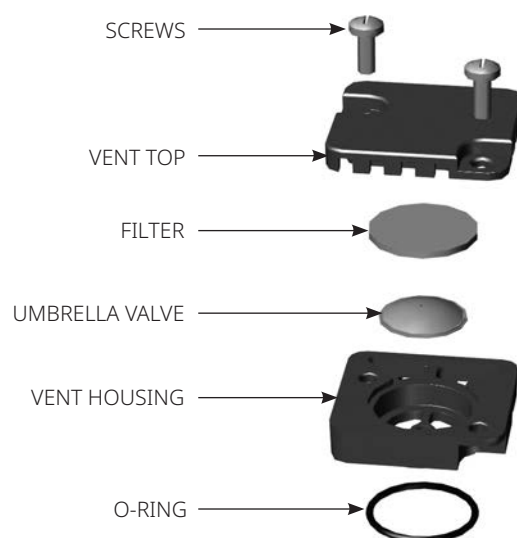
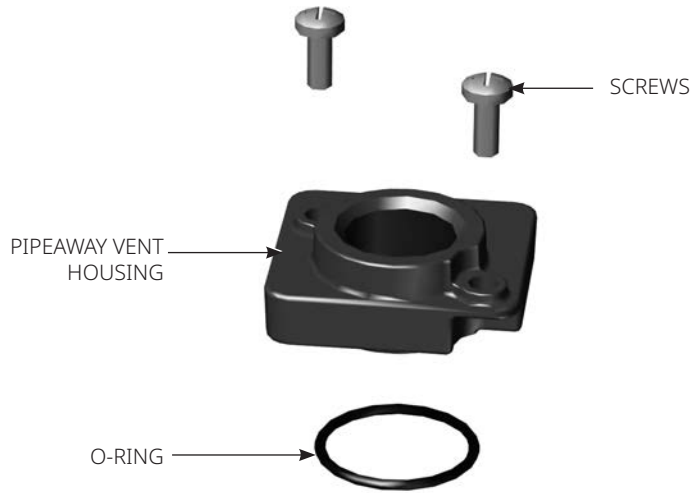

Figure 25. Pipe-Away Vent



Gauge Block

The Gauge Block is an optional feature to the DVC7K.

Removing the Gauge Block

1. Remove all accessories connected to the Gauge Block (for example: regulators).
2. Unscrew the four screws and remove the three O-rings.

NOTE

The screws will be retained by four small O-rings.

Figure 26. Gauge Block O-rings and Screws

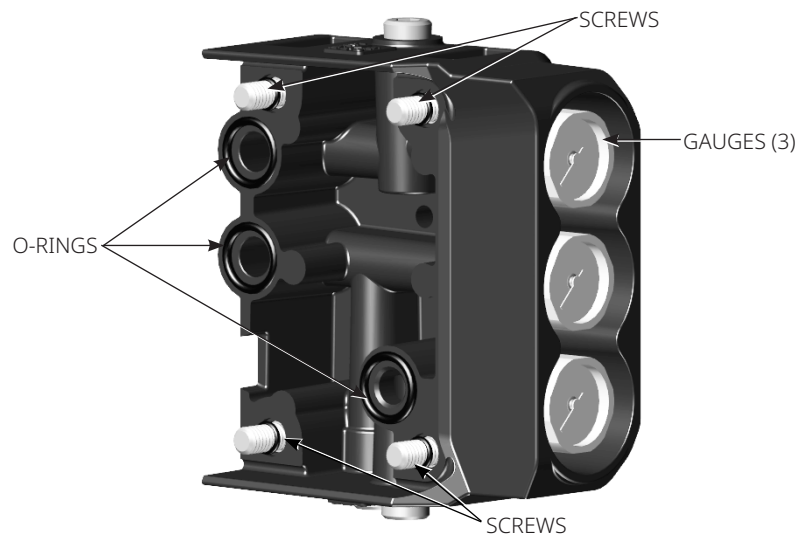

Replacing the Gauge Block

1. Remove the Gauge Block as described in the Removing the Gauge Block procedure on page 72.
2. Install the new Gauge Block as described in Section 4, Connect the Pneumatic Tubing in the quick start guide (D104766X012).

7.3 Troubleshooting

If communication or output difficulties are experienced with the instrument refer to Table 15, Instrument Troubleshooting. Also see Section 7.4, DVC7K Technical Support Checklist.

Checking Voltage Available

WARNING

Personal injury or property damage caused by fire or explosion may occur if this test is attempted in an area which contains a potentially explosive atmosphere or has been classified as hazardous.

To check the Voltage Available at the instrument, perform the following:

1. Connect the equipment in Figure 4 to the field wiring in place of the FIELDVUE instrument.
2. Set the control system to provide maximum output current.
3. Set the resistance of the 1 kilohm potentiometer shown in Figure 4 to zero.
4. Record the current shown on the milliammeter.
5. Adjust the resistance of the 1 kilohm potentiometer until the voltage read on the voltmeter is 10.0 V.
6. Record the current shown on the milliammeter.
7. If the current recorded in step 6 is the same as that recorded in step 4 (± 0.08 mA), the voltage available is adequate.
8. If the voltage available is inadequate, refer to Section Section 3, Wiring Practices.

Restore

Handheld Communicator (DD)	Device Settings > Restore/Restart Maintenance > Restore/Restart
-----------------------------------	--

There are two methods to restore a digital valve controller to a known state: Restore Custom Configuration or Restore Factory Configuration.

Restore Factory Configuration restores the digital valve controller to the factory defaults. For Firmware 1, the factory defaults that are restored are defined in Table 14.

Restore Custom Configuration restores the digital valve controller to a custom configuration defined by the user when ordered from the Factory.

Both methods require Write Protection to be disabled and Instrument Mode to be in Manual.

Table 14. Restored Factory Defaults

Parameter	Restored Default Setting
Input Characterization	Linear
Travel Integral Deadzone	0.25%
Travel Integral Gain	9.6 repeats / min
Cutoff High Trip Point	99.5%
Cutoff Low Trip Point	0.5%
Cutoff / Limit High Action	Cutoff
Cutoff / Limit Low Action	Cutoff

Table 15. Instrument Troubleshooting

Symptom	Possible Cause	Action
Input Current reading at instrument does not match actual current provided.	The Dip Switch is set to 24 V and not 4 to 20 mA	Check the Dip Switch on the Front Cover Assembly of the digital valve controller to ensure it is set to 4 to 20 mA.
	Low control system compliance voltage	Check system compliance voltage (see Section 3, Wiring Practices).
	Input Current Sensor not calibrated	Calibrate the Input Current Sensor (see Input Current Calibration).
	Current leakage	Excessive moisture in the terminal box can cause current leakage. Typically, the current will vary randomly if this is the case. Allow the inside of the terminal box to dry, then retest.
Instrument will not communicate.	Insufficient Voltage Available	Calculate Voltage Available (see Section 3, Wiring Practices). Voltage Available should be greater than or equal to 10.5 V DC.
	Controller output Impedance too low	Install a HART filter after reviewing Control System Compliance Voltage requirements (see Section 3, Wiring Practices).
	Cable capacitance too high	Review maximum cable capacitance limits (see Section 3, Wiring Practices).
	HART filter improperly adjusted	Check filter adjustment (see the appropriate HART filter instruction manual).
	Improper field wiring	Check polarity of wiring and integrity of connections. Make sure cable shield is grounded only at the control system.
	Controller output providing less than 4 mA to loop	Check control system minimum output setting, which should not be less than 3.8 mA.
	Disconnected loop wiring cable from Terminal Box to Front Cover Assembly	Verify the wiring cable to the Terminal Box is plugged in correctly.
	Front Cover Assembly DIP switch not set properly	Check for incorrect setting or broken DIP switch on the Front Cover Assembly. Reset switch or replace Front Cover Assembly, if switch is broken. See Table 13 for switch setting information.
	Front Cover Assembly failure	Use a 4 to 20 mA current source to apply power to the instrument. Terminal voltage across the LOOP+ and LOOP- terminals should be 8.0 to 9.5 V DC. If the terminal voltage is not 8.0 to 9.5 V DC, replace the Front Cover Assembly.
	Polling address incorrect	Use the handheld communicator to set the polling address to 0 (Device Settings > Setup Overview or Device Settings > Communications sections).
	Defective terminal box	Check that the terminal block screws are fully screwed in. If necessary, replace the terminal box assembly.
	Defective handheld communicator or modem cable	If necessary, repair or replace cable.

- continued -

Table 15. Instrument Troubleshooting (continued)

Symptom	Possible Cause	Action
Instrument will not calibrate, has sluggish performance or oscillates.	Configuration errors	Verify configuration: If necessary, disable Write Protection. If in Manual, place in Automatic. Check: Travel Sensor Motion Tuning set Zero Power Condition Feedback Connection The Dip Switch (should be 4 to 20 mA)
	Restricted pneumatic passages in I/P converter	Check screen in I/P converter supply port. Replace if necessary. If passages in I/P converter are restricted, replace I/P converter.
	O-ring(s) between I/P converter assembly missing or hard and flattened losing seal	Replace O-ring(s).
	I/P converter assembly damaged/corroded/clogged	Check for bent flapper, open coil (continuity), contamination, staining or dirty air supply. Coil resistance should be between 1680 to 1860 ohms. Replace I/P assembly if damaged, corroded, clogged or open coil.
	I/P converter assembly out of spec	I/P converter assembly nozzle may have been adjusted. Verify drive signal (55 to 80% for double-acting; 60 to 85% for single-acting) with the valve off the stops. Replace I/P converter assembly if drive signal is continuously high or low.
	Defective Module Base and Sensor Assembly seal	Check the Module Base and Sensor Assembly O-rings for condition and position. If necessary, replace the O-rings.
	Defective relay	Depress relay beam at adjustment location in shroud, look for increase in output pressure. Remove relay, inspect relay seal. Replace relay seal or relay if I/P converter assembly is good and air passages not blocked. Check relay adjustment.
	Defective 67CFR regulator, supply pressure gauge 67CFR regulator, supply pressure gauge jumps around	Replace 67CFR regulator.
Handheld communicator does not turn on.	Battery pack not charged	Charge battery pack. Note: Battery pack can be charged while attached to the handheld communicator or separately. The handheld communicator is fully operable while the battery pack is charging. Do not attempt to charge the battery pack in a hazardous area.

7.4 DVC7K Technical Support Checklist

Have the following information available prior to contacting your [Emerson sales office](#) for support.

1. Instrument serial number as read from nameplate _____
2. What are you experiencing issues with? Position Control Outputs (Transmitters and Switches)

Position Control

3. Is the digital valve controller responding to the control signal? Yes, No
If No, describe _____
4. Measure the voltage across the "Loop -" and Loop +" terminal box screws when the commanded current is 4.0 mA and 20.0 mA: ___ V @ 4.0 mA ___ V @ 20.0 mA. (These values should be around 8.6 V @ 4.0 mA and 9.5 V @ 20 mA).
5. Is it possible to communicate via HART to the digital valve controller? Yes, No
6. Do you have a Local User Interface (LUI)? Yes, No
 - a. If yes, are you able to navigate the LUI? Yes, No
7. What is the Control Tier? _____
8. What is the Application Mode? _____
9. What is the firmware version of the digital valve controller? _____
10. What is the hardware version of the digital valve controller? _____
11. What is the digital valve controller's Instrument Mode? Automatic, Manual, Local Override
12. Is simulation active? Yes, No
13. What is the digital valve controller's Setpoint Source Dip Switch position set to? 4 to 20 mA, 24 V
14. What are the following parameter readings?
 - a. Input Signal _____ Drive Signal _____%
 - b. Supply Pressure _____ Pressure A _____ Pressure B _____
 - c. Travel Target _____% Travel _____%
15. What alerts are active? _____

Outputs

16. Measure the current in series for the Transmitter when the valve is at 0% and 100% travel: ___ mA @ 0% ___ mA @ 100%.
 - a. Does the Transmitter output track actual valve position (example: 12 mA at 50%)? Yes, No
If No, what issues are you seeing with the transmitter? _____
 - b. What is the Transmitter Function? Disabled, 4 mA = Valve Open, 4 mA = Valve Closed
 - c. What is the Transmitter Fail Signal? Fail High (transmitter output >22.5 mA), Fail Low (transmitter output <3.6 mA)

17. Measure the voltage across the "Switch 1 -" and "Switch 1 +" terminal box screws when the valve is at 0% and 100% travel: ___ V @ 0% ___ V @ 100%.
 - a. What is the Switch 1 Function configured to? Disabled, Alert Switch, Limit Switch
 - i. Alert Switch
 1. What is the Switch 1 Alert Action? Alert Active, Alert Inactive
 2. Which Alert enables Switch 1? _____
 - ii. Limit Switch
 1. What is the Switch 1 Limit Action? Above Trip Point, Below Trip Point
 2. What is the Switch 1 Trip Point? _____

18. Measure the voltage across the "Switch 2 -" and "Switch 2 +" terminal box screws when the valve is at 0% and 100% travel: ___ V @ 0% ___ V @ 100%.
 - a. What is the Switch 2 Function configured to? Disabled, Alert Switch, Limit Switch
 - i. Alert Switch
 1. What is the Switch 2 Alert Action? Alert Active, Alert Inactive
 2. Which Alert enables Switch 2? _____
 - ii. Limit Switch
 1. What is the Switch 2 Limit Action? Above Trip Point, Below Trip Point
 2. What is the Switch 2 Trip Point? _____

Mounting

1. What Make, Brand, Style, Size, etc. actuator is the DVC7K mounted on?
 Make: _____ Drive Signal: _____ Style: _____ Size: _____
2. What is the full travel of the valve? _____
3. What Array is being used on the valve (i.e., what number is on it?) _____
4. What is the Mounting Kit part number? _____
5. If mounting kits are made by Impact Partner/Customer, please provide pictures of installation.
6. Is the Mounting kit installed per the instructions? Yes, No
7. What is the Zero Power Condition of the valve? Fail closed, Fail open

Section 8: Parts

8.1 Parts Ordering

Whenever corresponding with your [Emerson sales office](#) about this equipment, always mention the digital valve controller serial number.

WARNING

Use only genuine Fisher replacement parts. Components that are not supplied by Emerson should not, under any circumstances, be used in any Fisher instrument. Use of components not supplied by Emerson may void your warranty, might adversely affect the performance of the instrument and could cause personal injury and property damage.

8.2 Parts Kits

NOTE

All Standard kits with elastomers include internal nitrile elastomers and environmental seal silicone elastomers. Extreme temperature kits include fluorosilicone elastomers and environmental seal silicone elastomers.

Kit	Description	Part Number
1*	Elastomer Spare Parts Kit [kit contains parts to service one digital valve controller] Standard	GK01832X012
2*	Small Hardware Spare Parts Kit [kit contains parts to service one digital valve controller]	GK01833X012
3*	Seal Screen Kit [kit contains 25 seal screens and 25 O-rings]	14B5072X182
4*	Integral Mount Seal Kit (for 667 size 30i to 76i and GX actuators) [kit contains 5 seals]	19B5402X032
5*	Terminal Box Kit (see Figure 27) ⁽¹⁾ [kit contains terminal cup assembly; cup screw; ground screw; lock screw; terminal shield; and terminal box cap] without I/O Package with I/O Package	 GK01834X012 GK01835X012
* Recommended spare parts 1. Use only with replace in-kind.		

Figure 27. Terminal Box



WITH I/O OPTIONS



WITHOUT I/O OPTIONS

Kit	Description	Part Number
6	Terminal Box Cap Kit [kit contains lock screw and terminal box cap]	GK03961X012
7	Front Cover Assembly (see Figure 28) ⁽²⁾⁽³⁾ Standard [kit contains front cover assembly with two ribbon cables attached; E-rings, qty. 2; and hinge pin] Without I/O Package and with Local User Interface (LUI) With I/O Package and with Local User Interface (LUI) Extreme Temperature [kit contains front cover assembly with two ribbon cables attached; E-rings, qty. 2; and hinge pin] Without I/O Package and with Local User Interface (LUI) With I/O Package and with Local User Interface (LUI)	---
8	Battery Assembly [kit contains battery and sticker]	GK03960X012
9*	I/P Converter Kit [kit contains I/P; screws, qty. 4; I/P shroud; finger protector; O-ring; and seal screen] (see Figure 12 and 13). Standard Extreme Temperature	38B6041X152 38B6041X132
<p>2. Contact your Emerson sales office if a replacement front cover is needed. Front cover must match the terminal box kit (example: if terminal box has I/O package, the front cover must also have the I/O package).</p> <p>3. A battery is not included in Front Cover Assemblies. A Battery Assembly will need to be ordered for Standard units. However, a Battery Assembly should not be used in Extreme Temperature units because the batteries are only rated down to -40 °C.</p>		

Kit	Description	Part Number
10*	I/P Accessory Kit ⁽⁴⁾ [kit contains I/P finger guard]	GK04545X012
11*	Relay Assembly ⁽⁵⁾ [kit contains shroud; relay seal; and mounting screws, qty. 8 (refer to Figure 21 and 28)	
	Standard	
	Standard Bleed	
	For GX actuators	
	Single-acting direct (relay C)	38B5786X982
	Single-acting reverse (relay B)	38B5786X972
	For all actuators except GX	
	Single-acting direct (relay C)	38B5786X932
	Double-acting (relay A)	38B5786X852
	Single-acting reverse (relay B)	38B5786X892
	Low Bleed	
	For GX actuators	
	Single-acting direct (relay C)	38B5786X302
	Single-acting reverse (relay B)	38B5786X992
	For all actuators except GX	
	Single-acting direct (relay C)	38B5786X952
	Double-acting (relay A)	38B5786X872
	Single-acting reverse (relay B)	38B5786X912
	Extreme Temperature	
	Standard Bleed	
	Single-acting direct (relay C)	38B5786X942
	Double-acting (relay A)	38B5786X832
	Single-acting reverse (relay B)	38B5786X902
	Low Bleed	
	Single-acting direct (relay C)	38B5786X962
	Double-acting (relay A)	38B5786X882
	Single-acting reverse (relay B)	38B5786X922
12*	Spare Module Base and Sensor Assembly Kit [kit contains module base assembly; sensor assembly; seal; screws for sensor assembly, qty. 6; screws for module base, qty. 5; and O-rings, qty. 7]	GG76831X012
13	Vent Kit [kit contains umbrella valve; filter; screws, qty. 2; O-ring; vent housing; and vent cover] (see Figure 24)	GK01837X012
14	Pipe-Away Vent Connection Assembly for 1/2 in. Pipe [kit contains pipe-away vent; screws, qty. 2; and O-ring] (see Figure 25)	GK01925X012
15*	Spare I/P Shroud Kit [kit contains shroud and hex socket cap screws, qty. 4]	GE29183X012

* Recommended spare parts

4. The I/P Accessory Kit is an optional accessory and is only for the DVC7K.

5. The four longer screws in the Relay Assembly kit are for the DVC7K. The four shorter screws are for the DVC6200.

Kit	Description	Part Number
16	<p>Feedback Array Kit</p> <p>Sliding Stem (Linear) [kit contains feedback array and hex socket cap screws, qty. 2; washers, plain, qty. 2; external tooth lock washers, qty. 2 (only with aluminum feedback array kit)</p> <p>210 mm / 8-1/4 in. kit contains feedback array and hex socket cap screws, qty. 4; washers, plain, qty. 4; external tooth lock washers, qty. 4 (only with aluminum feedback array kit); and insert</p> <p>7 mm / 1/4 in. Aluminum</p> <p>19 mm / 3/4 in. Aluminum</p> <p>25 mm / 1 in. Aluminum</p> <p>38 mm / 1-1/2 in. Aluminum</p> <p>50 mm / 2-in. Aluminum</p> <p>110 mm / 4-1/8 in. Aluminum</p> <p>210 mm / 8-1/4 in. Aluminum</p> <p>Rotary Array Kit with Pointer and Scale [Kit contains feedback assembly, pointer assembly, travel indicator scale and M3 machine pan head screws, qty. 2] Aluminum</p> <p>Rotary Array Kit with Coupler [Kit contains feedback assembly, NAMUR coupler, M3 machine pan head screws qty. 2 and cap screw qt. 1] Aluminum</p> <p>Rotary Array Kit with Beacon [Kit contains feedback assembly, indicator beacon, M3 machine pan head screws qty. 2 and M6 cap screws qty. 4] Aluminum</p>	<p>GG20240X012</p> <p>GG20240X022</p> <p>GG20240X032</p> <p>GG20240X042</p> <p>GG20240X052</p> <p>GG20240X082</p> <p>GG20243X012</p> <p>GG10562X012</p> <p>GE71982X012</p> <p>GH19538X012</p>
17	<p>Alignment Template</p> <p>For linear actuators (except GX)</p> <p>For GX actuators</p>	<p>GE43826X012</p> <p>GE20586X012</p>
18	<p>Gauge Block [kit contains protective pneumatic plugs, qty. 3; protective gauge port plugs, qty. 3; gauge block; screws with O-rings, qty. 4; O-rings, qty. 3; and pipe plugs, qty. 5] (see Figure 29).</p> <p>Imperial</p> <p>Metric</p>	<p>GK01861X012</p> <p>GK01862X012</p>
19	<p>Gauge Block Spare Parts Kit</p> <p>[kit contains screws with O-rings, qty. 4 and O-rings, qty. 3] see Figure 29.</p>	<p>GK01864X012</p>
* Recommended spare parts		

8.3 Pressure Gauges, Pipe Plugs or Tire Valve Assemblies

Key	Description
47*	Pressure Gauge (see Figure 29) Double-acting (3 req'd); Single-acting (2 req'd) PSI/MPa Gauge Scale To 60 PSI, 0.4 MPa To 160 PSI, 1.1 MPa PSI/bar Gauge Scale To 60 PSI, 4 bar To 160 PSI, 11 bar PSI/KG/CM ² Gauge Scale To 60 PSI, 4 KG/CM ² To 160 PSI, 11 KG/CM ²
66	Pipe Plug, hex head For units w/o gauge
67	Tire Valve, used with Tire Valve Option only Double-acting (3 req'd) Single-acting (2 req'd)
* Recommended spare parts	

Figure 28. DVC7K Assembly Drawings

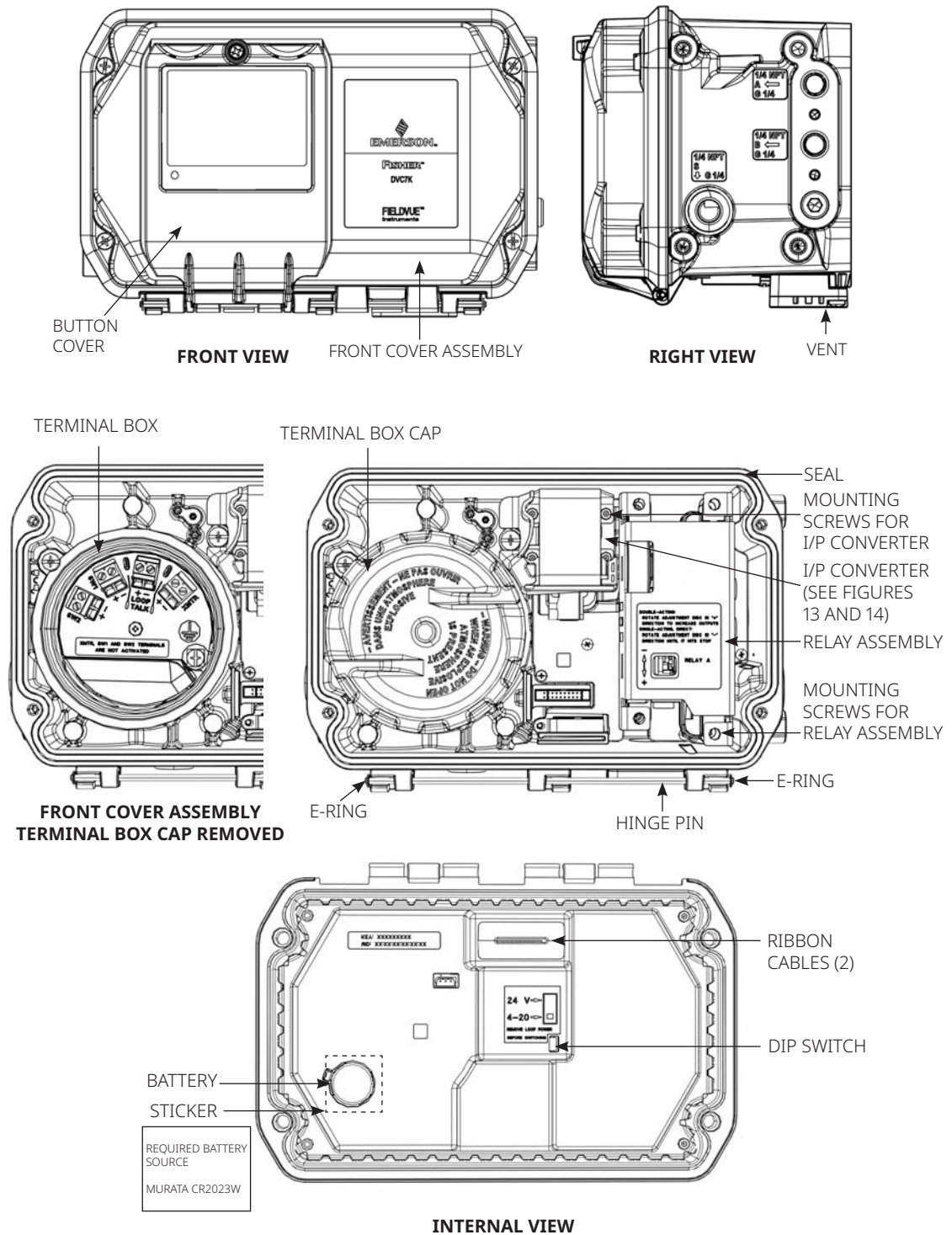

Figure 28. DVC7K Assembly Drawings (continued)

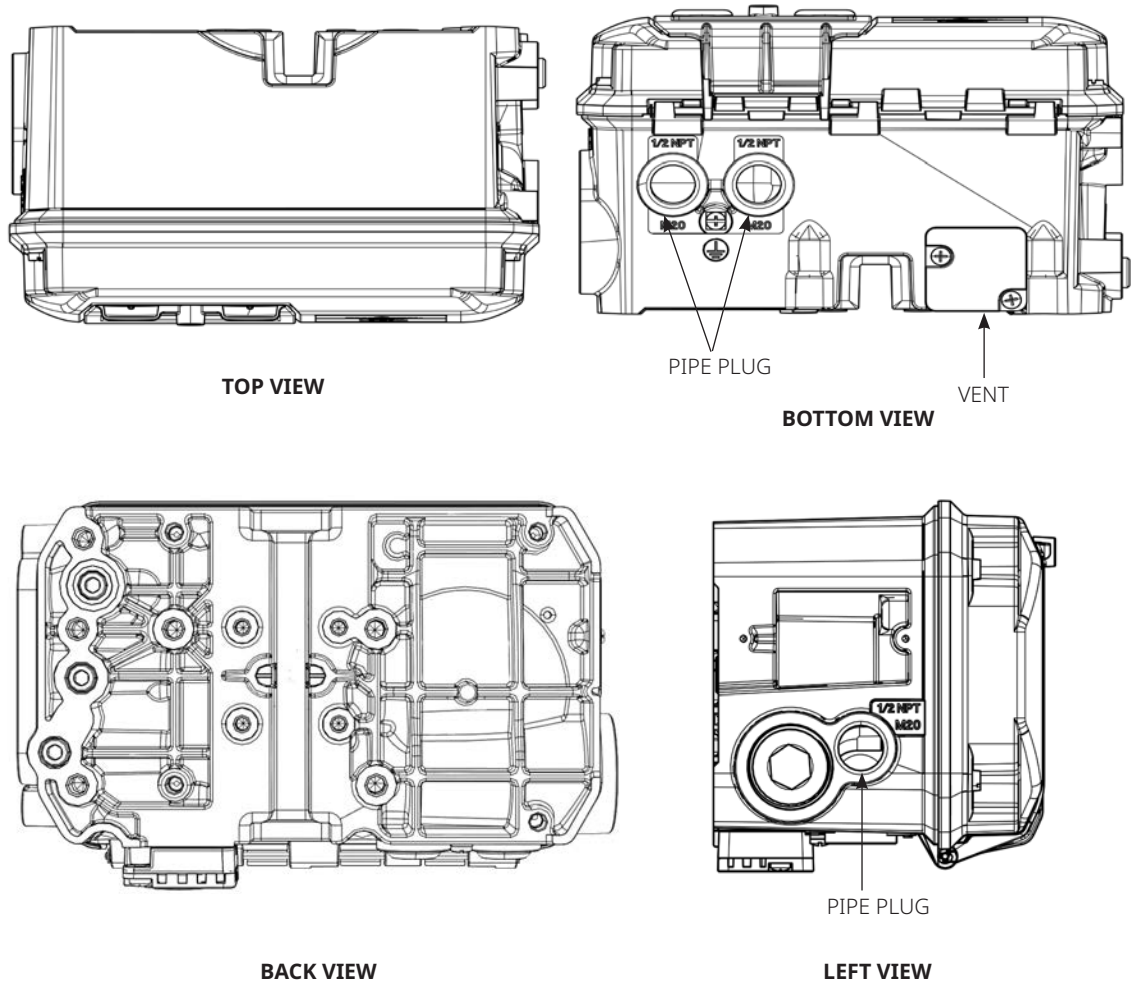
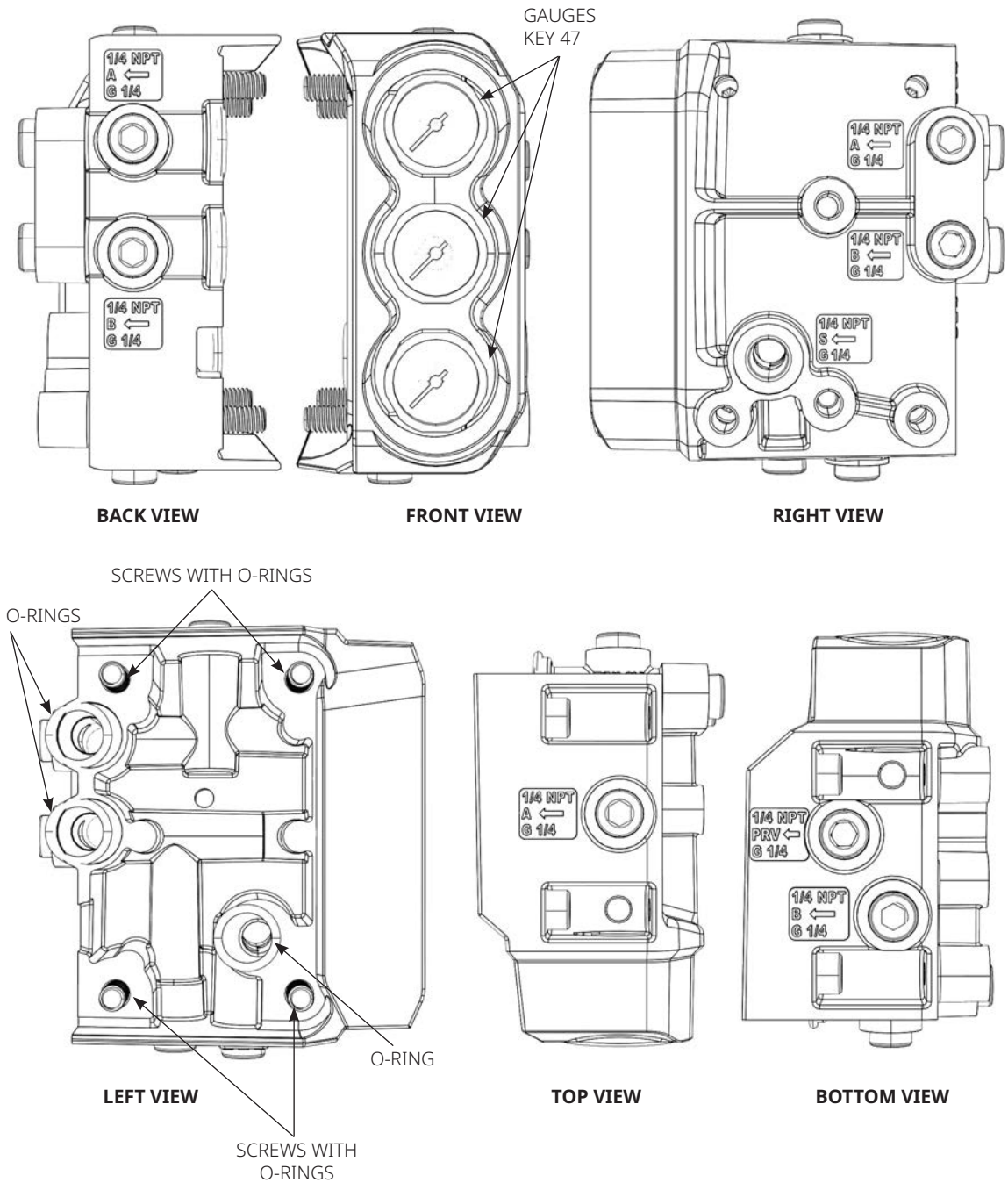

Figure 29. Gauge Block



NOTE: PIPE PLUGS AND TIRE VALVE ASSEMBLIES ARE NOT SHOWN

Appendix A: Principle of Operation

A.1 HART Communication

The HART (Highway Addressable Remote Transducer) protocol gives field devices the capability of communicating instrument and process data digitally. This digital communication occurs over the same two-wire loop that provides the 4 to 20 mA process control signal, without disrupting the process signal. In this way, the analog process signal, with its faster update rate, can be used for control. At the same time, the HART protocol allows access to digital diagnostic, maintenance and additional process data. The protocol provides total system integration via a host device.

The HART protocol uses frequency shift keying (FSK). Two individual frequencies of 1200 Hz and 2200 Hz are superimposed over the 4 to 20 mA current signal. These frequencies represent the digits 1 and 0 (see Figure A-1). By superimposing a frequency signal over the 4 to 20 mA current, digital communication is attained. The average value of the HART signal is zero, therefore no DC value is added to the 4 to 20 mA signal. Thus, true simultaneous communication is achieved without interrupting the process signal.

Figure A-1. HART Frequency Shift Keying Technique

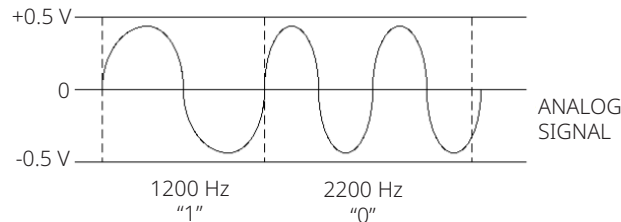

A6174

The HART protocol allows the capability of multidropping, i.e., networking several devices to a single communications line. This process is well suited for monitoring remote applications such as pipelines, custody transfer sites and tank farms. See Table 13 for instructions on changing the Front Cover Assembly DIP switch configuration to 24 V for multidrop.

A.2 Control Tiers and Application Modes

The DVC7K digital valve controller is available with two control tiers: Throttling Control and Discrete Control. The Throttling Control tier can be used for both throttling applications and on/off applications by configuring the Application Mode with the Local User Interface (LUI) or Device Description (DD) with a Emerson handheld communicator. The Discrete Control tier only provides on/off application capabilities. Table A-1 provides more information about the input signal and cutoff values for the different configurations and the Diagnostics section outlines the different diagnostic capabilities for the different configurations.

Table A-2. Cutoff Values by Control Tier / Application Mode

Control Tier ⁽¹⁾	Application Mode ⁽²⁾	Dip Switch	Cutoff Values	
			Low	High
Throttling Control (TC)	Throttling ⁽³⁾	4 to 20 mA	0.5% ⁽⁵⁾	99.5% ⁽⁵⁾
	On/Off ⁽⁴⁾	4 to 20 mA	50%	50%
		24 V DC ⁽⁶⁾	50%	50%
Discrete Control (DC)	On/Off ⁽⁴⁾	4 to 20 mA	50%	50%
		24 V DC		

1. Control Tier defined when ordered.
 2. Application Mode is field configurable for instruments with Throttling Control tier.
 3. Cutoff high and low values configurable over entire calibrated travel span for throttling valve control.
 4. Cutoff high and low values automatically set to 50% and are not user configurable for On/Off Application Modes.
 5. Default Cutoff Values used by device.
 6. If Signal Source Switch is 24 V DC then Application Mode must be On/Off.

A.3 DVC7K Digital Valve Controller

The DVC7K digital valve controller housing contains the module base and sensor assembly, terminal box, pneumatic input and output connections, I/P converter, pneumatic relay, front cover assembly and vent. The relay position is detected by sensing the magnet on the relay beam via a detector on the sensor assembly. This sensor is used for the minor loop feedback (MLFB) reading.

DVC7K digital valve controllers are loop-powered instruments that provide a control valve position proportional to an input signal from the control room. The following describes a double-acting digital valve controller mounted on a piston actuator.

The input signal is routed into the terminal box through a single twisted pair of wires and then to the printed circuit board in the Front Cover Assembly where it is read by the microprocessor, processed by a digital algorithm and converted into an analog I/P drive signal.

Figure A-2. Typical FIELDVUE Instrument to Personal Computer Connections for Device Description (DD) Software

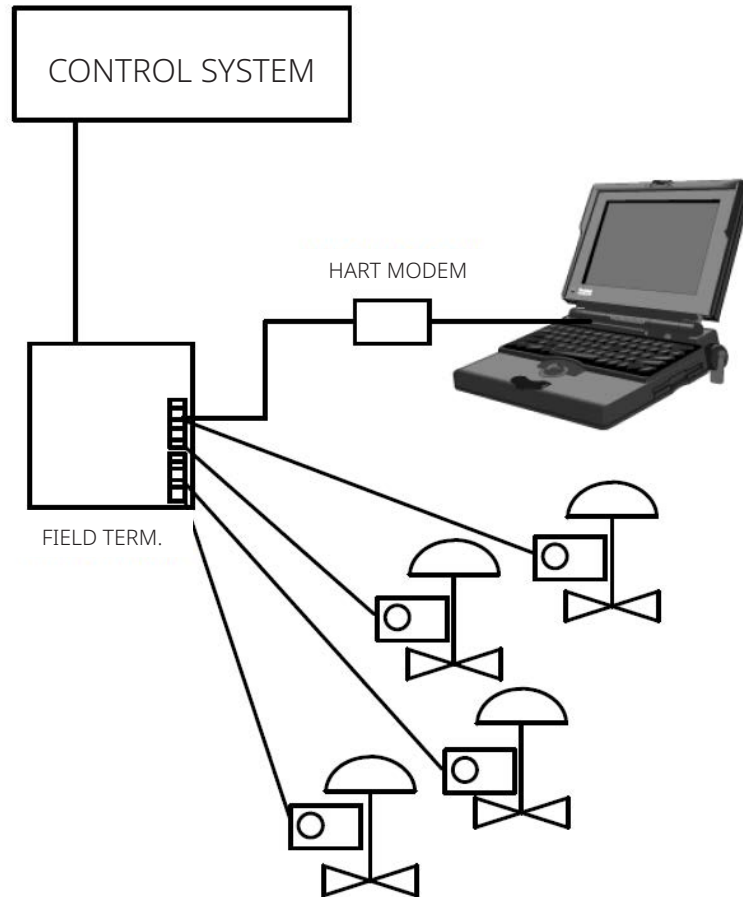

As the input signal increases, the drive signal to the I/P converter increases, increasing the I/P output pressure. The I/P output pressure is routed to the pneumatic relay submodule. The relay is also connected to supply pressure and amplifies the small pneumatic signal from the I/P converter. The relay accepts the amplified pneumatic signal and provides two output pressures. With increasing input (4 to 20 mA signal), the output A pressure always increases and the output B pressure decreases. The output A pressure is used for double-acting and single-acting direct applications. The output B pressure is used for double-acting and single-acting reverse applications. As shown in Figure A-3 and A-4, the increased output A pressure causes the actuator stem to move downward. Stem position is sensed by the non-contact travel feedback sensor. The stem continues to move downward until the correct stem position is attained. At this point the printed circuit board in the Front Cover Assembly stabilizes the I/P drive signal. This positions the flapper to prevent any further increase in nozzle pressure.

As the input signal decreases, the drive signal to the I/P converter submodule decreases, decreasing the I/P output pressure. The pneumatic relay decreases the output A pressure and increases the output B pressure. The stem moves upward until the correct position is attained. At this point the printed circuit board in the Front Cover Assembly stabilizes the I/P drive signal. This positions the flapper to prevent any further decrease in nozzle pressure.

Figure A-3. FIELDVUE DVC7K Digital Valve Controller Block Diagram

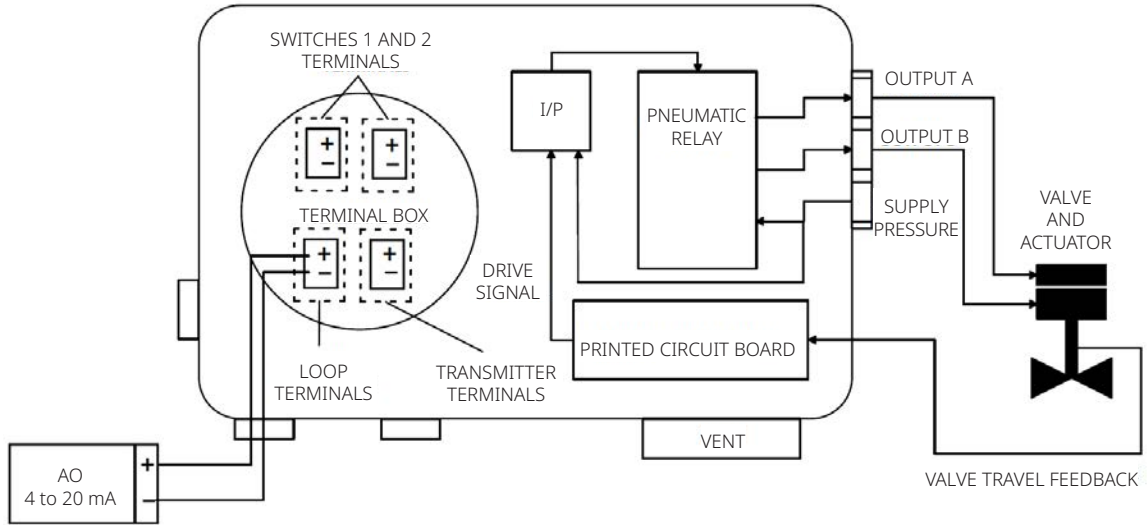

Figure A-4. FIELDVUE DVC7K Digital Valve Controller with Position Transmitter and Switches Block Diagram

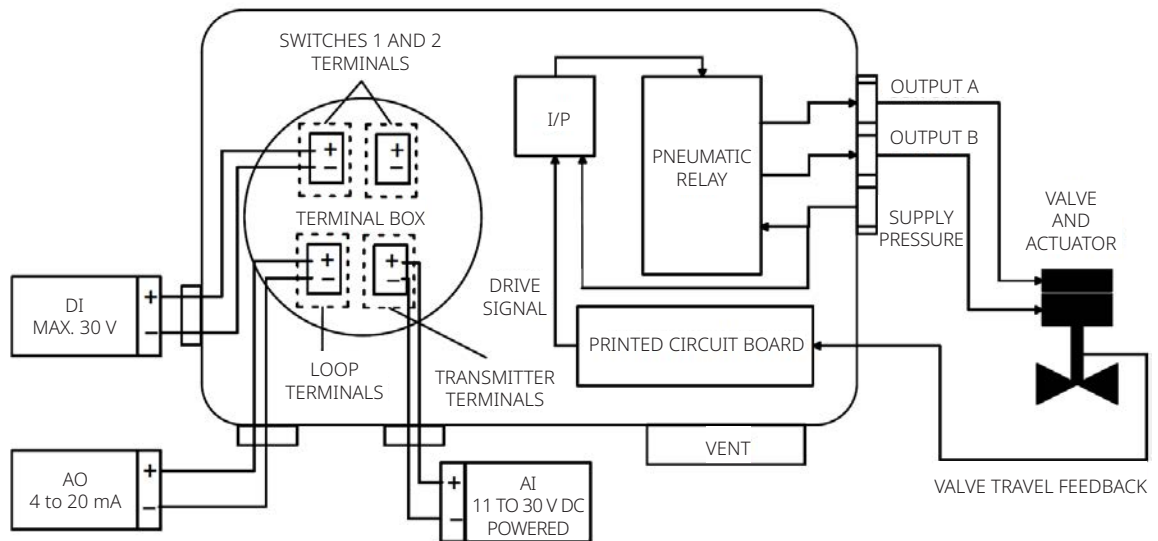
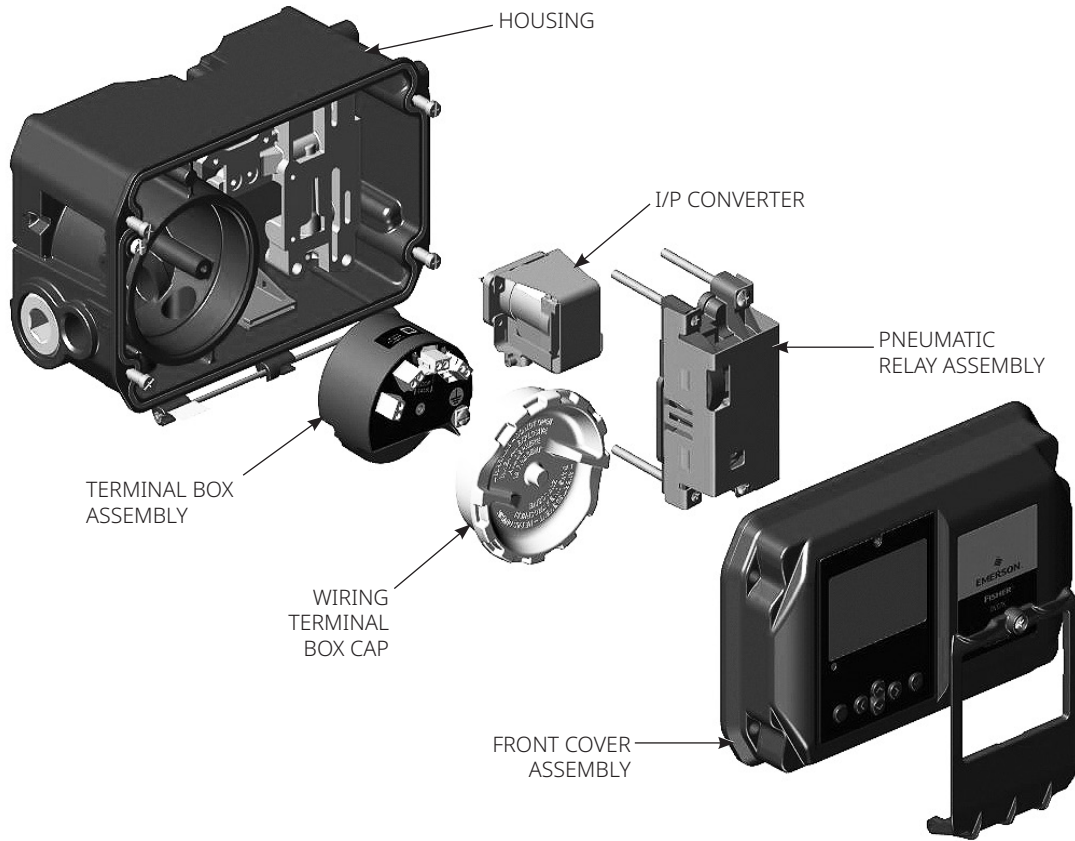

Figure A-5. FIELDVUE DVC7K Digital Valve Controller Assembly



Appendix B: Handheld Communicator Menu Trees

Figure B-1. Favorites

Favorites

- Tag
- Long Tag
- Instrument
- Change Mode
- Write Protection

Figure B-2. Process Variables

Process Variables

Device Overview

Variables

Active Alerts

Comm Status: Polled

Instrument Mode

Input Current⁽¹⁾

Setpoint

Travel

Travel Deviation

Input Characterization

Drive Signal

Pressures

Supply Pressure

Output A⁽²⁾

Output B⁽³⁾

Mapped Variables

Primary Variable

Secondary Variable

Tertiary Variable

Quaternary Variable

PV Units Compatibility

Status

Mode and Protection

Instrument Mode

Change Instrument Mode

Protection

Change Protection

Run Time

Power Ups

Current Temperature

Travel/Pressure

Travel

Input Current

Setpoint

Travel

Cycle Count

Pressure

Supply Pressure

Output 1⁽²⁾

Output 2⁽³⁾

Differential Pressure⁽⁴⁾

Stroke Information⁽⁵⁾

Stroke Open Baseline

Stroke Open Time

Stroke Close Baseline

Stroke Close Time

Configuration

Setpoint Source

Application Mode

Zero Power Condition

Restart Latch Options

Restart Latch Status

Relay Type

Outputs

Switch 1

Enabled/Disabled

Closed/Open

Switch 2

Enabled/Disabled

Closed/Open

Trends

Setpoint/Travel

Travel/Pressure

NOTES:

1. FOR 4 TO 20 mA ONLY

2. FOR DOUBLE-ACTING AND SINGLE-ACTING

3. FOR DOUBLE-ACTING AND REVERSE-ACTING

4. FOR DOUBLE-ACTING ONLY

5. FOR ON/OFF APPLICATION MODE ONLY

Figure B-3. Device Settings

Device Settings

Setup Overview

Mode and Protection

- Instrument Mode
- Change Instrument Mode
- Protection
- Change Protection

Guided Setup

- Guided Setup
- Mode and Protection
 - Instrument Mode
 - Change Instrument Mode
 - Protection
 - Change Protection

Identification

- Tag
 - Long Tag
 - Polling Address
 - Manufacturer
 - Device Type
 - Instrument Serial Number
 - Device Identifier
 - Message
 - Descriptor

Tiers

- Feature Tier
- Control Tier
- Application Mode

Revisions

- Hardware Revision
- Device Revision
- HART Protocol Revision
- Main Firmware Revision

Units

- Pressure
- Temperature
- Input Current

Positioner Performance

- Mode and Protection
 - Instrument Mode
 - Change Instrument Mode
 - Protection
 - Change Protection

Travel Control

- Input Current
- Relay Type
- Zero Power Condition
- Restart Latch Options
- Restart Latch Status

Cutoff/Limit High

- Cutoff/Limit High Action
- Cutoff High Trip Point
- Cutoff Rate High
- Travel Limit High Point

Cutoff/Limit Low

- Cutoff/Limit Low Action
- Cutoff Low Trip Point
- Cutoff Rate Low
- Travel Limit Low Point

Characterization

- Input Characterization
- Custom Characterization Table

Valve

- Mode and Protection
 - Instrument Mode
 - Change Instrument Mode
 - Protection
 - Change Protection

Identification

- Valve Manufacturer
- Valve Model
- Valve Serial Number
- Valve Size
- Valve Size Unit
- Valve Type
- ANSI Class
- Valve Criticality

Valve (continued)

Mechanics

- Dynamic Torque
- Breakout Torque
- Friction/Torque Adder
- Friction/Torque Unit
- Maximum Pressure
- Maximum Pressure Unit
- Maximum Temperature
- Maximum Temperature Unit

Construction1

- Flow Direction
- Bonnet Type
- Body/Bonnet Material
- Liner Material
- Liner Inner Diameter
- Liner Inner Diameter Unit

Construction2

- End Extension and Material
- End Connection In
- End Connection Out
- Flange Face Finish
- Packing Type
- Packing Material
- Isolation Valve Required
- Is Valve Lube Required
- Lube Type

Trim

- Trim Type
- Trim Characteristic
- Port Style
- Rated Travel
- Actual Travel
- Travel Unit
- Rated FL
- Rated Xt
- Rated Cv

continued on next page

Figure B-3. Device Settings (continued)

Setup Overview (continued)

Valve (continued)

- Characteristics
 - Unbalanced Area
 - Unbalanced Area Unit
 - Port Diameter
 - Port Diameter Unit
 - Stem Diameter
 - Stem Diameter Unit
 - Seat Material
 - Plug/Ball/Disk Material
 - Stem Material
 - Cage/Guide Material
 - Flow Tends To
 - Push Down To

Actuator

- Mode and Protection
 - Instrument Mode
 - Change Instrument Mode
 - Protection
 - Change Protection
- Identification
 - Actuator Manufacturer
 - Actuator Model
 - Actuator Style
- Mechanics_1
 - Actuator Size
 - Effective Area
 - Effective Area Unit
 - Lever Style
 - Lever Arm Length
 - Lever Arm Unit
- Mechanics_2
 - Spring Rate
 - Spring Rate Unit
 - Array Type
 - Actuator Orientation
 - Handwheel Type
 - Air Failure Valve
 - Air Failure Valve Set At

Actuator (continued)

- Motion
 - Air
 - Travel Sensor Motion
- Pressure
 - Maximum Available Supply Pressure
 - Nominal Available Supply Pressure
 - Minimum Available Supply Pressure
 - Maximum Allowable Pressure
 - Minimum Required Pressure
 - Actuator Pressure Unit
- Bench Set
 - Lower Bench Set
 - Upper Bench Set

Service Conditions

- Mode and Protection
 - Instrument Mode
 - Change Instrument Mode
 - Protection
 - Change Protection
- Fluid
 - Service
 - Fluid
 - Critical Pressure (Pc)
 - Critical Pressure Unit
- Flow Rate
 - Maximum Flow-Flow Rate
 - Normal Flow-Flow Rate
 - Minimum Flow-Flow Rate
 - Flow Rate Unit
- Inlet Pressure
 - Maximum Flow-Inlet Pressure
 - Normal Flow-Inlet Pressure
 - Minimum Flow-Inlet Pressure
 - Inlet Pressure Shut-off
 - Pressure Unit
- Outlet Pressure
 - Maximum Flow-Outlet Pressure
 - Normal Flow-Outlet Pressure
 - Minimum Flow-Outlet Pressure
 - Outlet Pressure Shut-off
 - Pressure Unit

continued on next page

Figure B-3. Device Settings (continued)

Setup Overview (continued)

Service Conditions (continued)

- Inlet Temperature
 - Maximum Flow-Inlet Temperature
 - Normal Flow-Inlet Temperature
 - Minimum Flow-Inlet Temperature
 - Inlet Temperature Shut-off
 - Inlet Temperature Unit
- Specific Gravity/Specific Weight/ Molecular Weight
 - Maximum Flow-SPG, SW or MW
 - Normal Flow-SPG, SW or MW
 - Minimum Flow-SPG, SW or MW
 - SPG, SW or MW Unit
- Viscosity/Specific Heats Ratio
 - Maximum Flow-Viscosity/Specific Heats Ratio
 - Normal Flow-Viscosity/Specific Heats Ratio
 - Minimum Flow-Viscosity/Specific Heats Ratio
 - Viscosity/Specific Heats Unit
- Vapor Pressure
 - Maximum Flow-Vapor Pressure PV
 - Normal Flow-Vapor Pressure PV
 - Minimum Flow-Vapor Pressure PV
 - Vapor Pressure (PV) Unit
- Required Cv
 - Maximum Flow-Required Cv
 - Normal Flow-Required Cv
 - Minimum Flow-Required Cv
- Travel
 - Maximum Flow-Travel
 - Normal Flow-Travel
 - Minimum Flow-Travel

Service Conditions (continued)

- Sound Pressure Levels
 - Maximum Flow-Allowable Sound Pressure Level
 - Normal Flow-Allowable Sound Pressure Level
 - Minimum Flow-Allowable Sound Pressure Level
 - Maximum Flow-Predicted Sound Pressure Level
 - Normal Flow-Predicted Sound Pressure Level
 - Minimum Flow-Predicted Sound Pressure Level

Line

- Mode and Protection
 - Instrument Mode
 - Change Instrument Mode
 - Protection
 - Change Protection
- Construction
 - Pipe Line Size In
 - Pipe Line Size Out
 - Pipe Line Insulation

Switches/Airset

- Mode and Protection
 - Instrument Mode
 - Change Instrument Mode
 - Protection
 - Change Protection
- Limit Switch/Valve Open
 - Valve Open Switch Manufacturer
 - Valve Open Switch Model
 - Valve Open Switch Type
 - Valve Open Switch Contacts/Rating/Action
- Limit Switch/Valve Closed
 - Valve Closed Switch Manufacturer
 - Valve Closed Switch Model
 - Valve Closed Switch Type
 - Valve Closed Switch Contacts/Rating/Action

continued on next page

Figure B-3. Device Settings (continued)

Setup Overview (continued)

Switches/Airset (continued)

Airset

- Airset Manufacturer
- Airset Model
- Airset Filter
- Airset Gauge
- Airset Set Pressure
- Airset Set Pressure Unit

Tests

- Hydro Pressure Test
- Hydro Pressure Unit
- ANSI/FCI Leakage Class
- Valve Assembly Diagnostic

Specials/Accessories

Mode and Protection

- Instrument Mode
- Change Instrument Mode
- Protection
- Change Protection

Hazardous Location Classification

Input/Output

Inputs

Input Current Range

- Upper Range Value
- Lower Range Value

Outputs

Mode and Protection

- Instrument Mode
- Change Instrument Mode
- Protection
- Change Protection

Mapped Variables

- Primary Variable
- Secondary Variable
- Tertiary Variable
- Quaternary Variable
- PV Units Compatibility

Positioner Transmitter

- Function
- Fail Signal

Deadband

- Travel Value Deadband

Switch 1*
(Function -SW 1 = Disabled)

- Function - SW 1

Switch 1
(Function -SW 1 = Limit)

- Function - SW 1
- Limit Action - SW 1
- Trip Point - SW 1
- Switch State

- Status
- State

Switch 1
(Function -SW 1 = Alert)

- Function - SW 1
- Limit Action - SW 1
- Trip Point - SW 1
- Switch 1 State

- Status
- State

*Switch menus change according to the value of the function (Disabled, Limit or Alert)

Switch 1 menus are shown; Menus are the same for Switch 2.

continued on next page

Figure B-3. Device Settings (continued)

Input/Ouput

Outputs (continued)

- Switch 1 Alert Configuration*
 - Switch 1 Electronics
 - Non-Volatile Memory Defect
 - Drive Signal
 - Drive Current
 - Transmitter Open Circuit
 - Electronic Defect
 - Switch 1 Pressure
 - Supply Pressure Low
 - Supply Pressure High
 - Port A Overpressurized
 - Switch 1 Travel
 - Travel Feedback Error
 - Travel Deviation
 - Travel High
 - Travel Low
 - Travel Limit/Cutoff High
 - Switch 1 History
 - Cycle Count High
 - Travel Accumulator High
 - Switch 1 Information Status
 - Device Misconfigured
 - Instrument Time is Approximate
 - Calibration in Progress
 - Temperature High
 - Temperature Low
 - Switch 1 Miscellaneous
 - Instrument Mode
 - Switch 1 Simulation
 - Status Simulation Active

Communication

Mode and Protection

- Instrument Mode
- Change Instrument Mode
- Protection
- Change Protection

Wired

- Polling Address

Display

Mode and Protection

- Instrument Mode
- Change Instrument Mode
- Protection
- Change Protection

Settings

- LUI Language Selection
- LUI Decimal Separator

Alerts

continued on next page

*Note: Switch menus change according to the value of the function (Disabled, Limit or Alert)

Switch 1 menus are shown; Menus are the same for Switch 2.

Figure B-3. Device Settings (continued)**Alerts****Electronics**

- Non-Volatile Memory Defect
 - Non-Volatile Memory Defect
 - Non-Volatile Memory Defect NE107 Category
- Volatile Memory Defect
 - Volatile Memory Defect
 - Volatile Memory Defect Category
- Drive Signal Alert
 - Drive Signal
 - Drive Signal Enable/Disable
 - Drive Signal Alert NE107 Category
- Drive Current
 - Drive Current
 - Drive Current Enable/Disable
 - Drive Current Category
- Transmitter Open Circuit
 - Transmitter Open Circuit
 - Transmitter Open Circuit Enable/Disable
 - Transmitter Open Circuit NE107 Category
- Electronic Defect
 - Electronic Defect
 - Electronic Defect NE107 Category

Information Status

- Device Misconfigured
 - Device Misconfigured
 - Device Misconfigured NE107 Category
- Instrument Time is Approximate
 - Instrument Time is Approximate
 - Instrument Time is Approximate Enable/Disable
 - Instrument Time is Approximate NE107 Category
- Calibration In Progress
 - Calibration In Progress
 - Calibration In Progress Enable/Disable
 - Calibration In Progress NE107 Category

Information Status (continued)

- Diagnostic in Progress
 - Diagnostic in Progress
 - Diagnostic in Progress Enable/Disable
 - Diagnostic in Progress NE107 Category
- Temperature High
 - Temperature High
 - Temperature High Enable/Disable
 - Temperature High NE107 Category
 - Temperature High Alert Point
- Temperature Low
 - Temperature Low
 - Temperature Low Enable/Disable
 - Temperature Low NE107 Category
 - Temperature Low Alert Point

Miscellaneous

- Loop Current Fixed
 - Loop Current Fixed
 - Loop Current Fixed Alert NE107 Category
- Loop Current Saturated
 - Loop Current Saturated
 - Loop Current Saturated Alert NE107 Category

Travel

- Current Values
 - Setpoint
 - Travel
 - Travel Deadband Value
- Travel Feedback Error
 - Travel Feedback Error
 - Travel Feedback Enable/Disable
 - Travel Feedback Error Category
- Travel Deviation
 - Travel Deviation
 - Travel Deviation Enable/Disable
 - Travel Deviation NE107 Category
 - Travel Deviation Alert Point
 - Travel Deviation Time

continued on next page

Figure B-3. Device Settings (continued)

Alerts

Travel (continued)

- Travel High
 - Travel High
 - Travel High Enable/Disable
 - Travel High NE107 Category
 - Travel High Alert Point
- Travel Low
 - Travel Low
 - Travel Low Enable/Disable
 - Travel Low NE107 Category
 - Travel Low Alert Point
- Travel Limit/Cutoffs
 - Travel Limit/Cutoff High
 - Travel Limit/Cutoff High
 - Travel Limit/Cutoff High Enable/Disable
 - Travel Limit/Cutoff High NE107 Category
 - Cutoff/Limit High Action
 - Cutoff High Trip Point
 - Travel Limit High Point
 - Travel Limit/Cutoff Low
 - Travel Limit/Cutoff Low
 - Travel Limit/Cutoff Low Enable/Disable
 - Travel Limit/Cutoff Low NE107 Category
 - Cutoff/Limit Low Action
 - Cutoff Low Trip Point
 - Travel Limit Low Point

Travel History

- Cycle Count High
 - Cycle Count High
 - Cycle Count High Enable/Disable
 - Cycle Count High NE107 Category
 - Cycle Count High Alert Point
 - Cycle Count

NOTES:

2. FOR DOUBLE-ACTING AND SINGLE-ACTING
3. FOR DOUBLE-ACTING AND REVERSE-ACTING
5. FOR ON/OFF TIER ONLY
6. OUTPUT B FOR REVERSE RELAY
7. OUTPUT B HERE FOR DOUBLE-ACTING ONLY

Travel History (continued)

- Travel Accumulator High
 - Active/Not Active status
 - Travel Accumulator High Enable/Disable
 - Travel Accumulator High NE107 Category
 - Travel Accumulator High Alert Point
 - Travel Accumulator
 - Travel Deadband Value
- Stroke Open Time⁽⁵⁾
 - Stroke Open Time
 - Stroke Open Time Enable/Disable
 - Stroke Open Time NE107 Category
 - Stroke Open Time Fast Trip Point
 - Stroke Open Time Slow Trip Point
 - Open Threshold
 - Stroke Open Baseline
- Stroke Close Time⁽⁵⁾
 - Stroke Close Time
 - Stroke Close Time Enable/Disable
 - Stroke Close Time NE107 Category
 - Stroke Close Time Fast Trip Point
 - Stroke Close Time Slow Trip Point
 - Close Threshold
 - Stroke Close Baseline

Pressure

- Current Values
- Output A⁽²⁾⁽⁶⁾
- Supply Pressure
- Output B⁽³⁾⁽⁷⁾
- Supply Pressure
 - Supply Pressure High
 - Supply Pressure High
 - Supply Pressure High Enable/Disable
 - Supply Pressure High NE107 Category
 - Supply Pressure High Alert Point
 - Supply Pressure Low
 - Supply Pressure Low
 - Supply Pressure Low Enable/Disable
 - Supply Pressure Low NE107 Category
 - Supply Pressure Low Alert Point
- Port A Overpressurized
 - Port A Overpressurized
 - Port A Overpressurized Enable/Disable
 - Port A Overpressurized NE107 Category
 - Port A Overpressurized Alert Point

Figure B-3. Device Settings (continued)

Calibration

Travel

- Auto Calibration
- Auto Calibration Status
- Manual Calibration
- Manual Calibration Status
- Relay Adjust

Pressure Sensor

- Pressure Sensor Calibration

Input Current

- Input Current Calibration

Tuning

Mode and Protection

- Instrument Mode
- Change Instrument Mode
- Protection
- Change Protection

Travel Tuning⁽⁸⁾

- Travel Tuning Set
- Integrator Deadzone
- Travel Integral Gain
- MLFB Gain
- Travel Proportional Gain
- Travel Velocity Gain

Restore/Restart

Restore

- Restore User Configuration
- Restore Factory Configuration

Device Information

Identification

- Tag
- Long Tag
- Polling Address
- Manufacturer
- Device Type
- Application Mode
- Device Identifier

Serial Numbers

- Work Order Number
- Valve Serial Number
- Instrument Serial Number

Revisions

- HART Protocol Revision
- Device Revision
- Hardware Revision
- Main Firmware Revision

DD Information

- Device Type
- DD Rev 1
- Build Date
- Build Number
- Copyright

Blink Device

- Blink Device

NOTE:

8. FOR THROTTLING ONLY

Figure B-4. Diagnostics

Diagnostics

Alerts

Device Status:
[NE107 Category] or Good

Refresh Alerts

<Active Alert Name 1>⁽⁹⁾

<Active Alert Name 1>
NE107 Category
Description
Recommended Action

History

Event Log
Read Event Log Records
Previous Records
Next Records
Clear Event Log

Proof Test

Valve Diagnostics⁽²⁾

Stroke Valve

Variables

Mapped Variables

Primary Variable
Secondary Variable
Tertiary Variable
Quaternary Variable

Status

Protection Status
Device Status
Run Time
Power Ups
Current Temperature

Travel/Pressure

Travel
Input Current
Setpoint
Travel
Cycle Count
Pressures
Supply Pressure
Output A⁽²⁾
Output B⁽³⁾
Differential Pressure⁽⁴⁾

Stroke Information⁽⁵⁾

Stroke Open Baseline
Stroke Open Time
Stroke Close Baseline
Stroke Close Time

Configuration

Setpoint Source
Application Mode
Zero Power Condition
Restart Latch Options
Restart Latch Status
Relay Type

Outputs

Switch 1
Status
State
Switch 2
Status
State

Trends

Setpoint/Travel

Travel/Pressure

Communication

Mode and Protection

Instrument Mode
Change Instrument Mode
Protection
Change Protection

Wired

Polling Address

Simulation

continued on next page

NOTES:

- 2. FOR DOUBLE-ACTING AND SINGLE-ACTING
- 3. FOR DOUBLE-ACTING AND REVERSE-ACTING
- 4. FOR DOUBLE-ACTING ONLY
- 5. FOR ON/OFF TIER ONLY
- 9. THERE CAN BE MORE THAN ONE ALERT LISTED

Figure B-4. Diagnostics (continued)

Simulation

Simulation Control

Enable/Disable Simulation

Electronics

Non-Volatile Memory Defect

Drive Signal Alert

Transmitter Open Circuit

Reference Voltage Fail

Drive Current Fail

Electronic Defect

Information Status

Instrument Misconfigured

Instrument Time is
Approximate

Calibration In Progress

Diagnostic in Progress

Temperature High

Temperature Low

Miscellaneous

Loop Current Fixed

Loop Current Saturated

Instrument Mode Alert

Sensor

Minor Loop Sensor Failure Alert

Travel Sensor Failure

Pressure Sensor Failure

Temperature Sensor Failure

Travel

Travel Deviation

Travel High

Travel Low

Travel Limit/Cutoff High

Travel Limit/Cutoff Low

NOTES:

5. FOR ON/OFF TIER ONLY

8. FOR THROTTLING ONLY

Travel History

Cycle Count High

Travel Accumulator

Stroke Open Time⁽⁵⁾

Stroke Close Time⁽⁵⁾

Pressure

Supply Pressure High

Supply Pressure Low

Port A Overpressurized

Calibration

Travel

Auto Calibration

Auto Calibration Status

Manual Calibration

Manual Calibration Status

Relay Adjust

Pressure Sensor

Pressure Sensor Calibration

Input Current

Input Current Calibration

Tuning

Mode and Protection

Instrument Mode

Change Instrument Mode

Protection

Change Protection

Travel Tuning⁽⁸⁾

Travel Tuning Set

Integrator Deadzone

Travel Integral Gain

Integral Gain

MLFB Gain

Travel Proportional Gain

Travel Velocity Gain

Device Information

Identification

Tag

Long Tag

Polling Address

Manufacturer

Device Type

Application Mode

Device Identifier

Serial Numbers

Work Order Number

Valve Serial Number

Instrument Serial Number

Revisions

HART Protocol Revision

Device Revision

Hardware Revision

Main Firmware Revision

DD Information

Device Type

DD Rev 1

Build Date

Build Number

Copyright

Blink Device

Blink Device

Appendix C: Local User Interface (LUI) Flow Chart

C.1 Overview

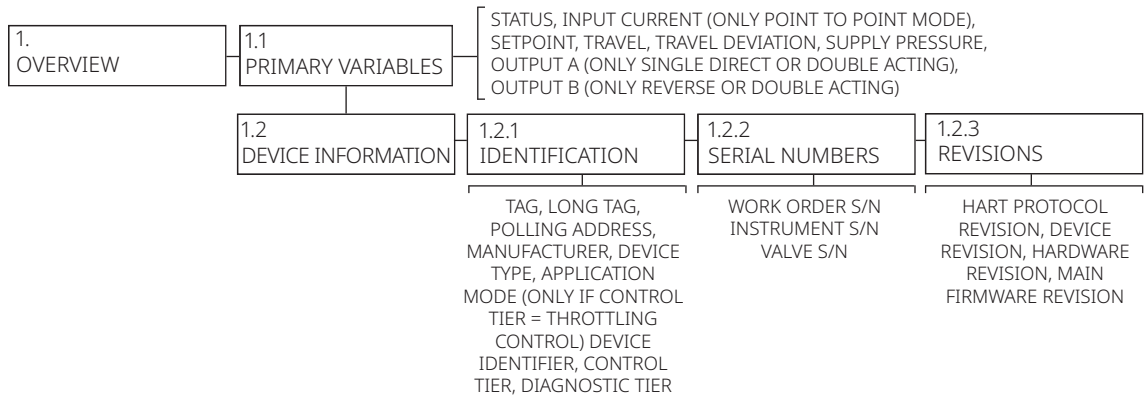

C.2 Configure

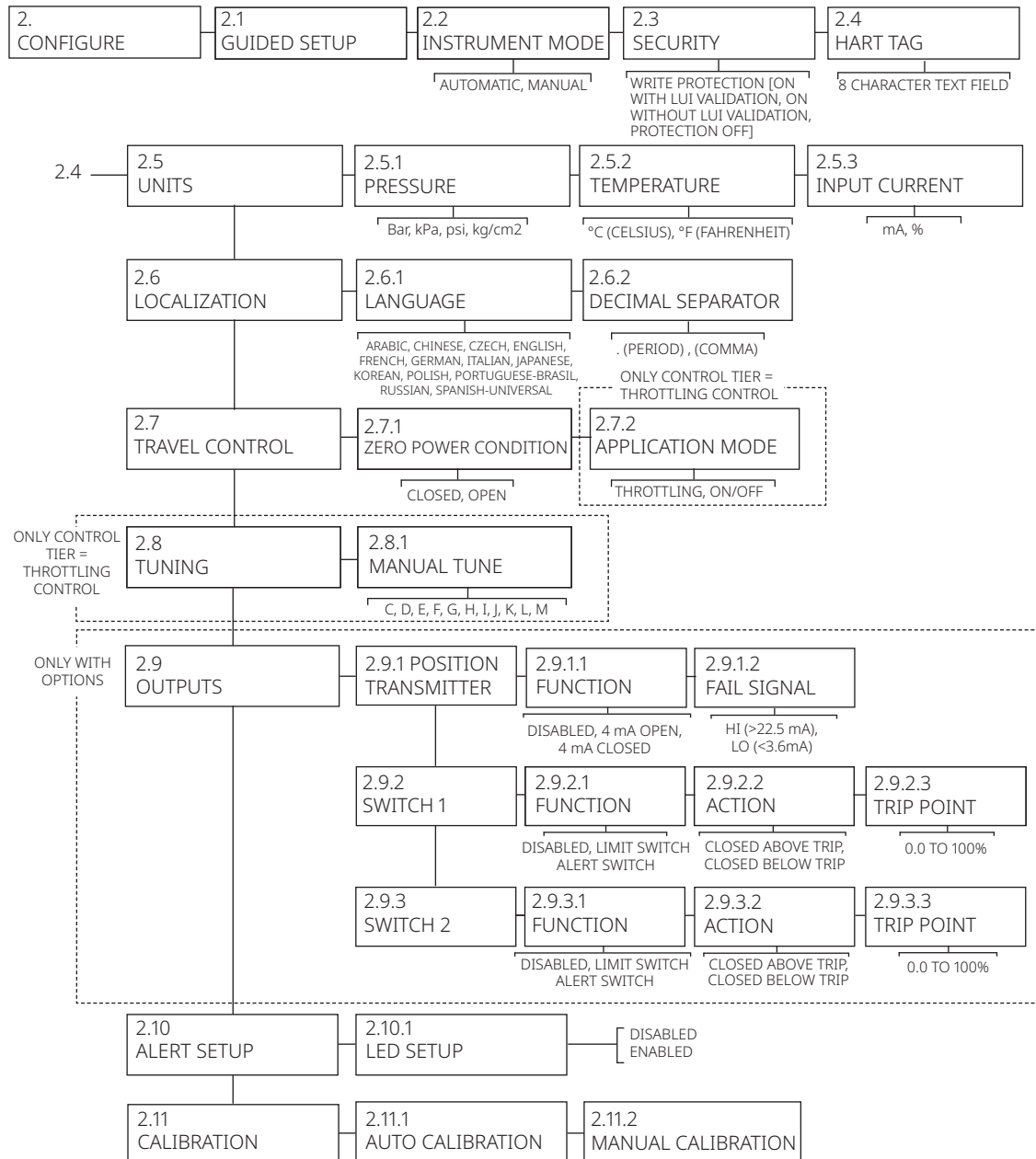

C.3 Service Tools

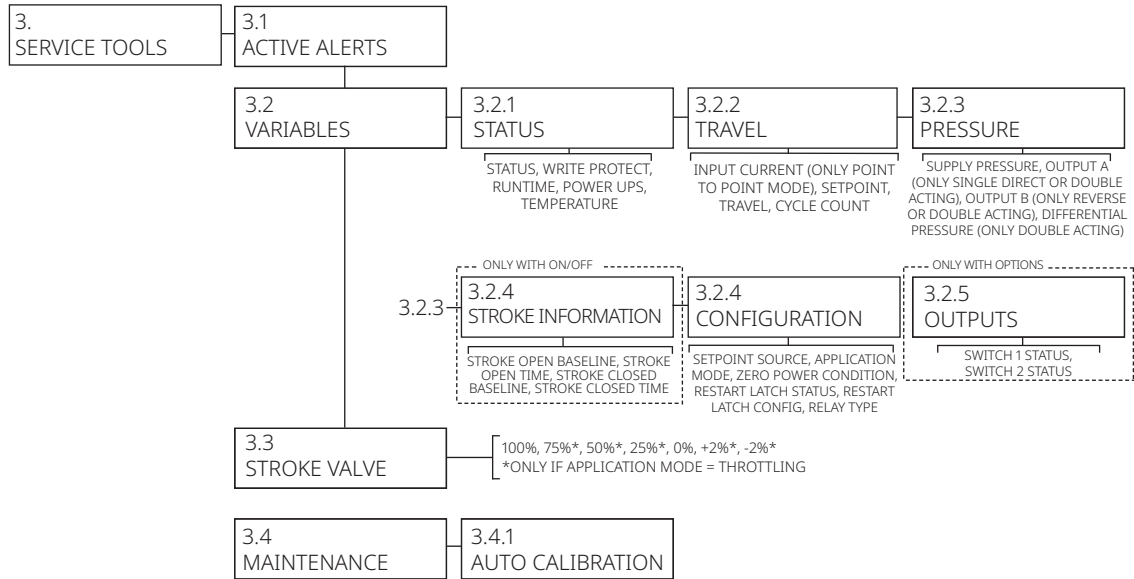

Appendix D: Third-Party Software Notices and Additional Terms and Conditions

Portions of the DVC7K utilize the following third-party software packages, which are distributed with DVC7K subject to the terms and conditions of the licenses indicated.

emFile software

emFile is licensed from SEGGER Microcontroller Systems LLC.

ST HAL

Copyright 2021 STMicroelectronics. All rights reserved.

Redistribution and use in source and binary forms, with or without modification, are permitted provided that the following conditions are met:

- Redistributions of source code must retain the above copyright notice, this list of conditions and the following disclaimer.
- Redistributions in binary form must reproduce the above copyright notice, this list of conditions and the following disclaimer in the documentation and/or other materials provided with the distribution.
- Neither the name of the copyright holder nor the names of its contributors may be used to endorse or promote products derived from this software without specific prior written permission.

THIS SOFTWARE IS PROVIDED BY THE COPYRIGHT HOLDERS AND CONTRIBUTORS "AS IS" AND ANY EXPRESS OR IMPLIED WARRANTIES, INCLUDING, BUT NOT LIMITED TO, THE IMPLIED WARRANTIES OF MERCHANTABILITY AND FITNESS FOR A PARTICULAR PURPOSE ARE DISCLAIMED. IN NO EVENT SHALL THE COPYRIGHT HOLDER OR CONTRIBUTORS BE LIABLE FOR ANY DIRECT, INDIRECT, INCIDENTAL, SPECIAL, EXEMPLARY OR CONSEQUENTIAL

DAMAGES (INCLUDING, BUT NOT LIMITED TO, PROCUREMENT OF SUBSTITUTE GOODS OR SERVICES; LOSS OF USE, DATA OR PROFITS; OR BUSINESS INTERRUPTION) HOWEVER CAUSED AND ON ANY THEORY OF LIABILITY, WHETHER IN CONTRACT, STRICT LIABILITY OR TORT (INCLUDING NEGLIGENCE OR OTHERWISE) ARISING IN ANY WAY OUT OF THE USE OF THIS SOFTWARE, EVEN IF ADVISED OF THE POSSIBILITY OF SUCH DAMAGE.

ARM CMSIS

TERMS AND CONDITIONS FOR USE, REPRODUCTION AND DISTRIBUTION

1. Definitions.

"License" shall mean the terms and conditions for use, reproduction and distribution as defined by Sections 1 through 9 of this document.

"Licensor" shall mean the copyright owner or entity authorized by the copyright owner that is granting the License.

"Legal Entity" shall mean the union of the acting entity and all other entities that control, are controlled by or are under common control with that entity. For the purposes of this definition, "control" means (i) the power, direct or indirect, to cause the direction or management of such entity, whether by contract or otherwise, or (ii) ownership of fifty percent (50%) or more of the outstanding shares, or (iii) beneficial ownership of such entity.

"You" (or "Your") shall mean an individual or Legal Entity exercising permissions granted by this License.

“Source” form shall mean the preferred form for making modifications, including but not limited to software source code, documentation source and configuration files.

“Object” form shall mean any form resulting from mechanical transformation or translation of a Source form, including but not limited to compiled object code, generated documentation and conversions to other media types.

“Work” shall mean the work of authorship, whether in Source or Object form, made available under the License, as indicated by a copyright notice that is included in or attached to the work (an example is provided in the Appendix A).

“Derivative Works” shall mean any work, whether in Source or Object form, that is based on (or derived from) the Work and for which the editorial revisions, annotations, elaborations or other modifications represent, as a whole, an original work of authorship. For the purposes of this License, Derivative Works shall not include works that remain separable from, or merely link (or bind by name) to the interfaces of, the Work and Derivative Works thereof.

“Contribution” shall mean any work of authorship, including the original version of the Work and any modifications or additions to that Work or Derivative Works thereof, that is intentionally submitted to Licensor for inclusion in the Work by the copyright owner or by an individual or Legal Entity authorized to submit on behalf of the copyright owner. For the purposes of this definition, “submitted” means any form of electronic, verbal or written communication sent to the Licensor or its representatives, including but not limited to communication on electronic mailing lists, source code control systems and issue tracking systems that are managed by, or on behalf of, the Licensor for the purpose of discussing and improving the Work, but excluding communication that is conspicuously marked or otherwise designated in writing by the copyright owner as “Not a Contribution.”

“Contributor” shall mean Licensor and any individual or Legal Entity on behalf of whom a Contribution has been received by Licensor and subsequently incorporated within the Work.

2. Grant of Copyright License. Subject to the terms and conditions of this License, each Contributor hereby grants to You a perpetual, worldwide, non-exclusive, no-charge, royalty-free, irrevocable copyright license to reproduce, prepare Derivative Works of, publicly display, publicly perform, sublicense and distribute the Work and such Derivative Works in Source or Object form.
3. Grant of Patent License. Subject to the terms and conditions of this License, each Contributor hereby grants to You a perpetual, worldwide, non-exclusive, no-charge, royalty-free, irrevocable (except as stated in this section) patent license to make, have made, use, offer to sell, sell, import and otherwise transfer the Work, where such license applies only to those patent claims licensable by such Contributor that are necessarily infringed by their Contribution(s) alone or by combination of their Contribution(s) with the Work to which such Contribution(s) was submitted. If You institute patent litigation against any entity (including a cross-claim or counterclaim in a lawsuit) alleging that the Work or a Contribution incorporated within the Work constitutes direct or contributory patent infringement, then any patent licenses granted to You under this License for that Work shall terminate as of the date such litigation is filed.
4. Redistribution. You may reproduce and distribute copies of the Work or Derivative Works thereof in any medium, with or without modifications and in Source or Object form, provided that You meet the following conditions:
 - You must give any other recipients of the Work or Derivative Works a copy of this License; and
 - You must cause any modified files to carry prominent notices stating that You changed the files; and
 - You must retain, in the Source form of any Derivative Works that You distribute, all copyright, patent, trademark and attribution notices from the Source form of the Work, excluding those notices that do not pertain to any part of the Derivative Works; and

If the Work includes a “NOTICE” text file as part of its distribution, then any Derivative Works that You distribute must include a readable copy of the attribution notices contained within such NOTICE file, excluding those notices that do not pertain to any part of the Derivative Works, in at least one of the following places: within a NOTICE text file distributed as part of the Derivative Works; within the Source form or documentation, if provided along with the Derivative Works; or, within a display generated by the Derivative Works, if and wherever such third-party notices normally appear. The contents of the NOTICE file are for informational purposes only and do not modify the License. You may add Your own attribution notices within Derivative Works that You distribute, alongside or as an addendum to the NOTICE text from the Work, provided that such additional attribution notices cannot be construed as modifying the License.

You may add Your own copyright statement to Your modifications and may provide additional or different license terms and conditions for use, reproduction or distribution of Your modifications or for any such Derivative Works as a whole, provided Your use, reproduction and distribution of the Work otherwise complies with the conditions stated in this License.

5. **Submission of Contributions.** Unless You explicitly state otherwise, any Contribution intentionally submitted for inclusion in the Work by You to the Licensor shall be under the terms and conditions of this License, without any additional terms or conditions. Notwithstanding the above, nothing herein shall supersede or modify the terms of any separate license agreement you may have executed with Licensor regarding such Contributions.
6. **Trademarks.** This License does not grant permission to use the trade names, trademarks, service marks or product names of the Licensor, except as required for reasonable and customary use in describing the origin of the Work and reproducing the content of the NOTICE file.
7. **Disclaimer of Warranty.** Unless required by applicable law or agreed to in writing, Licensor provides the Work (and each Contributor provides its Contributions) on an “AS IS” BASIS, WITHOUT WARRANTIES OR CONDITIONS OF ANY KIND, either express or implied, including, without limitation, any warranties or conditions of TITLE, NON-INFRINGEMENT, MERCHANTABILITY or FITNESS FOR A PARTICULAR PURPOSE. You are solely responsible for determining the appropriateness of using or redistributing the Work and assume any risks associated with Your exercise of permissions under this License.
8. **Limitation of Liability.** In no event and under no legal theory, whether in tort (including negligence), contract or otherwise, unless required by applicable law (such as deliberate and grossly negligent acts) or agreed to in writing, shall any Contributor be liable to You for damages, including any direct, indirect, special, incidental or consequential damages of any character arising as a result of this License or out of the use or inability to use the Work (including but not limited to damages for loss of goodwill, work stoppage, computer failure or malfunction or any and all other commercial damages or losses), even if such Contributor has been advised of the possibility of such damages.
9. **Accepting Warranty or Additional Liability.** While redistributing the Work or Derivative Works thereof, You may choose to offer and charge a fee for, acceptance of support, warranty, indemnity or other liability obligations and/or rights consistent with this License. However, in accepting such obligations, You may act only on Your own behalf and on Your sole responsibility, not on behalf of any other Contributor, and only if You agree to indemnify, defend and hold each Contributor harmless for any liability incurred by or claims asserted against, such Contributor by reason of your accepting any such warranty or additional liability.

END OF TERMS AND CONDITIONS

Glossary

Alert Point

An adjustable value that, when exceeded, activates an alert.

Algorithm

A set of logical steps to solve a problem or accomplish a task. A computer program contains one or more algorithms.

Alphanumeric

Consisting of letters and numbers.

ANSI (acronym)

The acronym ANSI stands for the American National Standards Institute.

ANSI Class

Valve pressure/temperature rating.

Application Mode

Determines the control available for the instrument. If the Control Tier is Throttling Control (TC) the user may select between the following two options. However, if the Control Tier is Discrete Control (DC) the Application Mode will always be On/Off. See also Control Tier.

- Throttling: Travel Output of 0% through 100%
- On/Off: Travel Output of 0% or 100%

Bench Set

Pressure, supplied to an actuator, required to drive the actuator through rated valve travel. Expressed in pounds per square inch.

Byte

A unit of binary digits (bits). A byte consists of eight bits.

Configuration

Stored instructions and operating parameters for a FIELDVUE Instrument.

Control Loop

An arrangement of physical and electronic components for process control. The electronic components of the loop continuously measure one or more aspects of the process, then alter those aspects as necessary to achieve a desired process condition. A simple control loop measures only one variable. More sophisticated control loops measure many variables and maintain specified relationships among those variables.

Control Tier

Determines the control available for the instrument. See also Application Mode.

- Throttling Control (TC):
Supports Throttling and On/Off Application Modes
- Discrete Control (DC):
Supports On/Off Application Mode

Controller

A device that operates automatically to regulate a controlled variable.

Current-to-Pressure (I/P) Converter

An electronic component or device that converts a milliamp signal to a proportional pneumatic pressure output signal.

Cycle Counter

The capability of a FIELDVUE instrument to record the number of times the travel changes direction. The change in direction must occur after the deadband has been exceeded before it can be counted as a cycle.

Cycle Count High Alert

Checks the difference between the Cycle Counter and the Cycle Count High Alert Point. Cycle Count High Alert is active when the cycle counter value exceeds the Cycle Count High Alert Point. It clears after you reset the Cycle Counter to a value less than the alert point.

Cycle Count High Alert Point

An adjustable value which, when exceeded, activates the Cycle Count Alert. Valid entries are 0 to 4 billion cycles.

Deviation

Usually, the difference between setpoint and process variable. More generally, any departure from a desired or expected value or pattern.

Device ID

Unique identifier embedded in the instrument at the factory.

Device Revision

Revision number of the interface software that permits communication between the handheld communicator and the instrument.

Drive Signal

The signal to the I/P converter from the printed circuit board in the Front Cover Assembly. It is the percentage of the total microprocessor effort needed to drive the valve fully open.

Drive Signal Alert

Checks the drive signal and calibrated travel. If one of the following conditions exists for more than the user configured Drive Signal Deviation Time, the Drive Signal Alert is active. If none of the conditions exist, the alert is cleared.

If Zero Power Condition = Closed

The alert is active when:
drive signal <10% and calibrated travel >3%
drive signal >90% and calibrated travel <97%

If Zero Power Condition = Open

The alert is active when:
drive signal <10% and calibrated travel <97%
drive signal >90% and calibrated travel >3%

Equal Percentage

A valve flow characteristic where equal increments of valve stem travel produce equal percentage changes in existing flow. One of the input characteristics available for a FIELDVUE Instrument. See also, Linear and Quick Opening.

Feedback Signal

Indicates to the instrument the actual position of the valve. The travel sensor provides the feedback signal to the instrument's printed circuit board in the Front Cover Assembly.

Firmware Revision

The revision number of the instrument firmware. Firmware is a program that is entered into the instrument at time of manufacture and cannot be changed by the user.

Full Ranged Travel

Current, in mA, that corresponds with the point where ranged travel is maximum, i.e., limited by the mechanical travel stops.

Gain

The ratio of output change to input change.

Hardware Revision

Revision number of the Fisher instrument hardware. The physical components of the instrument are defined as the hardware.

HART (acronym)

The acronym HART stands for Highway Addressable Remote Transducer.

HART Universal Revision

Revision number of the HART Universal Commands which are the communications protocol for the instrument.

Input Characteristic

The relationship between the ranged travel and ranged input. Possible values include: linear, equal percentage and quick opening.

Input Current

The current signal from the control system that serves as the analog input to the instrument. See also Input Signal.

Input Current Units

Units in which the input current is displayed and maintained in the instrument.

Input Range

The input range that corresponds to the travel range.

Instrument Mode

Determines if the instrument responds to its analog input signal. There are two instrument modes:

- Automatic (AUTO): For a fully functioning instrument, the instrument output changes in response to analog input changes. Typically changes to setup or calibration cannot be made when the instrument mode is in Automatic.
- Manual (MAN): The instrument output does not change in response to analog input changes when the instrument mode is in Manual.
- Local Override (LO): Local Override is when the device is latched to a Zero Power Condition. It occurs when the device is reset in Automatic mode which is caused by loss of power. Local Override is not a user configurable instrument mode.

Some setup parameters can be changed only when the instrument mode is in Manual.

Instrument Serial Number

The serial number assigned to the instrument by the factory but can be changed during setup. The instrument serial number should match the serial number on the instrument nameplate.

Leak Class

Defines the allowable leakage by a valve when it is closed. Leak class numbers are listed in two standards: ANSI/FCI 70-2 and IEC 534-4.

Linear

A valve flow characteristic where changes in flow rate are directly proportional to changes in valve stem travel. One of the input characteristics available for a FIELDVUE Instrument. See also, Equal Percentage and Quick Opening.

Linearity, dynamic

Linearity (independent) is the maximum deviation from a straight line best fit to the opening and closing curves and a line representing the average value of those curves.

Local User Interface

The screen and navigation buttons located physically on the instrument.

LUI (acronym)

The acronym LUI stands for Local User Interface.

Memory

A type of semiconductor used for storing programs or data. FIELDVUE instruments use three types of memory: Random Access Memory (RAM), Read Only Memory (ROM) and Non-Volatile Memory (NVM). See also these listings in this glossary.

Menu

A list of programs, commands or other activities that you select by using the arrow keys to highlight the item then pressing ENTER or by entering the numeric value of the menu item.

Non-Volatile Memory (NVM)

A type of semiconductor memory that retains its contents even though power is disconnected. NVM contents can be changed during configuration unlike ROM which can be changed only at time of instrument manufacture. NVM stores configuration restart data.

Polling Address

Address of the instrument. If the digital valve controller is used in a point-to-point configuration, set the polling address to 0. If it is used in a multidrop configuration or split range application, set the polling address to a value from 0 to 63.

Pressure Sensor

A FIELDVUE instrument internal device that senses pneumatic pressure. The DVC7K has three pressure sensors: one to sense supply pressure and two to sense the output pressures.

Primary Master

Masters are communicating devices. A primary master is a communicating device permanently wired to a field instrument. Typically, a HART-compatible control system is the primary master.

In contrast, a secondary master is not often permanently wired to a field instrument. The handheld communicator or a computer running Device Description (DD) software communicating through a HART modem could be considered a secondary master.

Note: If one type of master changes the instrument mode to Manual, the same type must change it back to Automatic. For example, if a device set up as a primary master changes the instrument mode to Manual, a device set up as a primary master must be used to change the instrument mode back to Automatic.

Primary Variable (PV) Units Compatibility Mode

If PV Units Compatibility Mode is Off, the PV Units will always be mA. If it is On, the PV Units will be consistent with the units configured by the user.

Quick Opening

A valve flow characteristic where most of the change in flow rate takes place for small amounts of stem travel from the closed position. The flow characteristic curve is basically linear through the first 40% of stem travel. One of the input characteristics available for a FIELDVUE Instrument. See also, Equal Percentage and Linear.

Random Access Memory (RAM)

A type of semiconductor memory that is normally used by the microprocessor during normal operation that permits rapid retrieval and storage of programs and data. See also Read Only Memory (ROM) and Non-Volatile Memory (NVM).

Rate

Amount of change in output proportional to the rate of change in input.

Read-Only Memory (ROM)

A memory in which information is stored at the time of instrument manufacture. You can examine but not change ROM contents.

Seat Load

Force exerted on the valve seat, typically expressed in pounds force per lineal inch of port circumference. Seat load is determined by shutoff requirements.

Setpoint Source

Defines where the instrument reads its set point. The following setpoint sources are available for a FIELDVUE Instrument:

- Input Current: The instrument receives its travel set point over the 4 to 20 mA loop.
- Digital: The instrument receives its set point digitally when in Manual Mode.

Software

Microprocessor or computer programs and routines that reside in alterable memory (usually RAM), as opposed to firmware, which consists of programs and routines that are programmed into memory (usually ROM) when the instrument is manufactured. Software can be manipulated during normal operation, firmware cannot.

Stroke Close Time Fast Trip Point

Minimum time, in seconds, for the travel to decrease through the entire ranged travel. This rate is applied to any travel decrease. Valid entries are greater than 0 seconds.

Stroke Close Time Slow Trip Point

Maximum time, in seconds, for the travel to decrease through the entire ranged travel. This rate is applied to any travel decrease. Valid entries are greater than 0 seconds.

Stroke Open Time Fast Trip Point

Minimum time, in seconds, for the travel to increase through the entire ranged travel. This rate is applied to any travel increase. Because of friction, actual valve travel may not respond in exactly the same time frame. Valid entries are greater than 0 seconds.

Stroke Open Time Slow Trip Point

Maximum time, in seconds, for the travel to increase through the entire ranged travel. This rate is applied to any travel increase. Because of friction, actual valve travel may not respond in exactly the same time frame. Valid entries are greater than 0 seconds.

Stroking Time

The time, in seconds, required to move the valvem from its fully open position to fully closed or vice versa.

Temperature Sensor

A device within the FIELDVUE instrument that measures the instrument's internal temperature.

Travel

Movement of the valve stem or shaft which changes the amount the valve is open or closed.

Travel Accumulator

The capability of a FIELDVUE instrument to record total change in travel. The value of the Travel Accumulator increments when the magnitude of the change exceeds the Travel Deadband. To reset the Travel Accumulator, set it to zero.

Travel Accumulator High Alert

Checks the difference between the Travel Accumulator value and the Travel Accumulator High Alert Point. The Travel Accumulator High Alert is active when the Travel Accumulator value exceeds the Travel Accumulator High Alert Point. It clears after you reset the Travel Accumulator to a value less than the alert point.

Travel Accumulator High Alert Point

An adjustable value which, when exceeded, activates the Travel Accumulator High Alert. Valid entries are 0% to 4 billion %.

Travel Deadband

The percent (%) of ranged travel around the travel reference point where no change in alert status will occur. This prevents the alert from toggling on and off when operating near the alert point.

Valid entries are 0% to 100%. Typical value is between 2% and 5%. See also, Travel Deviation Alert, Travel High Alert, Travel Low Alert, Cycle Count High Alert and Travel Accumulator High Alert.

Travel Deviation

The difference between the analog input signal (in percent of ranged input), the "target" travel and the actual "ranged" travel.

Travel Deviation Alert

Checks the difference between the target and the ranged travel. If the difference exceeds the Travel Deviation Alert Point for more than the Travel Deviation Time, the Travel Deviation Alert is active. It remains active until the difference between the Travel Target and the Travel is less than the Travel Deviation Alert Point minus the Travel Deadband.

Travel Deviation Alert Point

An adjustable value for the target travel and the ranged travel difference, expressed in percent. When this value is exceeded by the travel deviation for more than the Travel Deviation Time, the Travel Deviation Alert is active. Valid entries are 0% to 100%. Typically, this is set to 5%.

Travel Deviation Time

The time, in seconds, that the travel deviation must exceed the Travel Deviation Alert Point before the alert is active. Valid entries are 1 to 360 seconds.

Travel High Alert

The Travel High Alert is active if the travel exceeds the travel high alert point. Once the alert is active, the alert will clear when the travel falls below the travel high alert point minus the Travel Deadband.

Travel High Alert Point

Value of the travel, in percent of ranged travel, which, when exceeded, activates the Travel High Alert. Valid entries are -25% to 125%.

Travel Limit High Point

Defines the cutoff point for the travel, in percent of ranged travel. Once travel exceeds the cutoff, the drive signal is set to either maximum or minimum, depending on the Zero Power

Condition. Minimum opening time or minimum closing time are not in effect while the travel is beyond the cutoff. Use the travel cutoff to obtain the desired seat load or to be sure the valve is fully open.

Travel Limit Low Point

Defines the cutoff point for the travel, in percent of ranged travel. Once travel exceeds the cutoff, the drive signal is set to either maximum or minimum, depending on the Zero Power

Condition. Minimum opening time or minimum closing time are not in effect while the travel is beyond the cutoff. Use the travel cutoff to obtain the desired seat load or to be sure the valve is fully open.

Travel Limit/Cutoff High Alert

The Travel Limit/Cutoff High Alert is active if either the Travel Threshold High Action is Cutoff and Travel exceeds the Travel Cutoff High Point or Travel Threshold High Action is Limit and Travel exceeds the Travel Limit High Point.

Travel Limit/Cutoff Low Alert

The Travel Limit/Cutoff Low Alert is active if either the Travel Threshold Low Action is Cutoff and Travel is below the Travel Cutoff Low Point or Travel Threshold Low Action is Limit and Travel falls below the Travel Limit Low Point.

Travel Low Alert

The Travel Low Alert is active if the travel is below the travel low alert points. Once the alert is active, the alert will clear when the travel exceeds the travel low alert point plus the Travel Deadband.

Travel Low Alert Point

Value of the travel, in percent of ranged travel, which, when exceeded, activates the Travel Alert Low Alert. Valid entries are -25% to 125%.

Travel Range

Travel, in percent of calibrated travel, that corresponds to the input range.

Travel Sensor

A device within the FIELDVUE instrument that senses valve stem or shaft movement. The travel sensor in the DVC7K is the Hall Effect sensor that measures the position of the magnetic assembly.

Travel Sensor Motion

Increasing or decreasing air pressure causes the magnet assembly to move up or down or the rotary shaft to turn clockwise or counterclockwise. Guided Setup asks if it can move the valve to determine travel.

Travel Threshold High Action

Allows the user to control the behavior when the setpoint is high. The user can select from the following options:

- Disabled: no action occurs when the setpoint is high
- Cutoff: Travel Limit/Cutoff High Alert will activate if the Travel exceeds the Travel Cutoff High Point.
- Limit: Travel Limit/Cutoff High Alert will activate if the Travel exceeds the Travel Limit High Point.

Travel Threshold Low Action

Allows the user to control the behavior when the setpoint is low. The user can select from the following options:

- Disabled: no action occurs when the setpoint is low.
- Cutoff: Travel Limit/Cutoff Low Alert will activate if the Travel is below the Travel Cutoff Low Point.
- Limit: Travel Limit/Cutoff Low Alert will activate if the Travel is below the Travel Limit Low Point.

Tuning

The adjustment of control terms or parameter values to produce a desired control effect.

Tuning Set

Preset values that identify gain settings for a FIELDVUE instrument. The tuning set and supply pressure together determine an instrument's response to input signal changes.

Write Protection

Determines if commands from a HART device can calibrate and/or configure certain parameters in the instrument. There are three types of write protection:

- On with LUI Validation: Prohibits changing protected setup parameters and calibration. The instrument is Protected until write protection is disabled from the Local User Interface (LUI).
- On without LUI Validation: Prohibits changing protected setup parameters and calibration. The instrument is Protected until write protection is write protection to be disabled from the software (example: device description).
- Off: Permits both configuration and calibration. The instrument is "unprotected."

Zero Power Condition

The position of the valve (open or closed) when the electrical power to the instrument is removed. Zero Power Condition (ZPC) is determined by relay and actuator action as follows:

Single Acting Direct (Relay C) Upon loss of electrical power instrument goes to zero air output at port A.

Double-Acting (Relay A) Upon loss of electrical power instrument goes to full supply air output at port B. A goes to zero air output.

Single-Acting Reverse (Relay B) Upon loss of electrical power instrument goes to full supply air output at Port B.

 Fisher.com

 Facebook.com/FisherValves

 LinkedIn.com/groups/3941826

 X.com/FisherValves

D104767X012 © 2023, 2024 Fisher Controls International LLC. All rights reserved.

Neither Emerson, nor any of its affiliated entities assume responsibility for the selection, use or maintenance of any product. Responsibility for proper selection, use, and maintenance of any product remains solely with the purchaser and end user.

Fisher and FIELDVUE are marks owned by one of the companies in the Emerson business unit of Emerson Electric Co. Emerson and the Emerson logo are trademarks and service marks of Emerson Electric Co. All other marks are the property of their respective owners.

The contents of this publication are presented for informational purposes only, and while every effort has been made to ensure their accuracy, they are not to be construed as warranties or guarantees, express or implied, regarding the products or services described herein or their use or applicability. All sales are governed by our terms and conditions, which are available upon request. We reserve the right to modify or improve the designs or specifications of such products at any time without notice.

Emerson
Marshalltown, Iowa 50158 USA
Sorocaba, 18087 Brazil
Cernay, 68700 France
Dubai, United Arab Emirates
Singapore 128461 Singapore

www.Fisher.com

FISHER™

EMERSON