

Fisher™ 4194S Differential Pressure Controllers

Contents

1. Introduction	2
Scope of Manual	2
Description	2
Specifications	5
Educational Services	5
2. Installation	7
Actuator Mounting	7
Panel Mounting	7
Wall Mounting	7
Pipestand Mounting	7
Pressure Connections	9
Process Pressure	9
Supply Pressure	10
Vent	10
Remote Set Up Point Pressure (Option M)	10
3. Controller Operation	11
Operating Information	11
Adjustments	11
Manual Set Point	11
Remote Set Point	11
Proportional Band (Differential Gap)	11
Changing Controller Action	11
Auto/Manual Switching (Option E)	11
Startup Checks	12
Startup	13
Calibration	14
Process Zero and Span Adjustment	14
Remote Set Point Zero and Span (Option M)	14
Setting Switching Points	15
Direct-Acting Controllers	15
Reverse-Acting Controllers	17
Principle of Operation	17
Overall Operation	17
Remote Set Point	19
Auto/Manual Option	19
4. Maintenance	21
Troubleshooting	22
Changing Controller Action	23
Replacing Controller Parts	24
Process Pressure Scale	24
Relay	25
Case and Cover	26
Gauges	26
Pressure Control Block	26

Figure 1-1. Fisher 4194S Differential Pressure Controllers

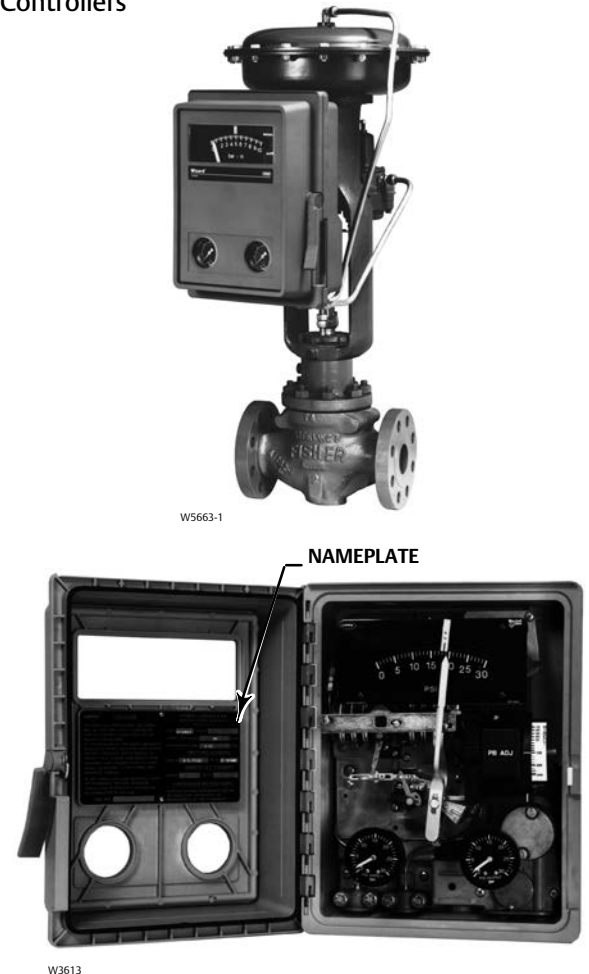

Supply Tubing and Positive Feedback Tubing Assemblies	27
Proportional Band Knob, Nozzle Assembly, and Set Point Beam Assembly	27
Flapper Flexure Pivot Assembly	31
Positive Feedback Bellows	34
Links	36
Link Number 1	36
Link Number 2	38

Contents (cont'd)

Link Number 3	39	Aligning Linkage	49
Link Number 4	39	Zero and Span Adjustment	49
Link Number 5	40	Linearity Adjustment	50
Long Pivot Assembly	40	Auto/Manual (Option E)	50
Short Pivot Assembly	40	Replacing the Auto/Manual Station	51
Process Drive Flexure	41	Disassembly	51
Process Tubing	41	Assembly	51
Capsular Element Assembly	41	Replacing the Switch Body Assembly, Lever O-Ring, Switch Body O-Ring, and Tubing Assembly	51
Maintenance Calibration	42	Disassembly	52
Precalibration Procedures	42	Assembly	52
Aligning the Drive Bracket Assembly	42	Replacing the Loader Range Spring, Diaphragm Assembly, Ball Seat, Tubing, and Ball	53
Setting the Travel Stops	42	Disassembly	53
Aligning Linkage	43	Assembly	53
Zero and Span Adjustment	43	Replacing the Loader Valve Plug and Valve Plug Spring	54
Linearity Adjustment	44	5. Parts Ordering	55
Flapper Alignment	44	Parts Kits	55
Remote Set Point (Option M)	45	Parts List	55
Replacing Parts	45	General Controller Parts	55
Pivot Assembly A	46	Mounting Parts	57
Pivot Assembly B	46	Pipestand Mounting	57
Drive Flexure	47	Panel Mounting	57
Tubing	47	Wall Mounting	57
Remote Set Point Capsular Element Assembly	47	Actuator Casing Mounting	57
Link A	48	Actuator Yoke Mounting	57
Link B	48	Tubing	57
Maintenance Calibration	48	Fittings	57
Precalibration Procedure	48		
Setting Travel Stops	49		

Section 1 Introduction

Scope of Manual

This instruction manual provides installation, operating, calibration, maintenance, and parts ordering information for the 4194S differential pressure indicating controllers. Portions of this manual apply only to specific configurations in the 4194S product line. These configurations of the controller are indicated by letter suffixes in the type number that correspond to the mode and option designated in table 1-2. Refer to table 1-2 for available 4194S configurations. The type number of the controller is on the nameplate. Refer to figure 1-1 for the location of the nameplate.

Description

The controllers described in this manual provide a differential gap output with the options as shown in table 1-2. The controller shows process differential pressure and set point on an easy-to-read process scale. The controller output is a pneumatic signal that operates a final control element.



Do not install, operate or maintain a 4194S differential pressure indicating controller without first being fully trained and qualified in valve, actuator and accessory installation, operation and maintenance. To avoid personal injury or property damage it is important to carefully read, understand, and follow all of the contents of this manual, including all safety cautions and warnings. If you have any questions about these instructions, contact your [Emerson sales office](#) before proceeding.

Table 1-1. Specifications

<p>Available Configurations See table 1-2</p> <p>Sensing Element Range (Input Signal) Lower and Upper Range Limits: As shown in table 1-3 Maximum Allowable Pressure: As shown in table 1-3</p> <p>Process Scale Matched to the range of the process differential pressure as standard. Optional scales available⁽¹⁾</p> <p>Process Connections Standard: 1/4 NPT internal stainless steel (all input ranges) Optional: 1/2 NPT internal stainless steel</p> <p>Output Signal Differential Gap Range: 0 and 1.4 bar (0 and 20 psig) or 0 and 2.4 bar (0 and 35 psig) Action: Field-reversible between direct (increasing differential pressure increases output pressure) or reverse (increasing differential pressure decreases output pressure).</p> <p>Supply and Output Connections 1/4 NPT internal</p> <p>Supply Pressure Requirements See table 1-4</p> <p>Supply Pressure Medium Air or Natural Gas Supply medium must be clean, dry and non-corrosive Per ISA Standard 7.0.01 A maximum 40 micrometer particle size in the air system is acceptable. Further filtration down to 5 micrometer particle size is recommended. Lubricant content is not to exceed 1 ppm weight (w/w) or volume (v/v) basis. Condensation in the air supply should be minimized.</p>	<p>Per ISO 8573-1 <i>Maximum particle density size: Class 7</i> <i>Oil content: Class 3</i> <i>Pressure Dew Point: Class 3 or at least 10°C less than the lowest ambient temperature expected</i></p> <p>Remote Set Point Pressures 0.2 to 1.0 bar (3 to 15 psig) or 0.4 to 2.0 bar (6 to 30 psig)</p> <p>Controller Adjustments Differential Gap Control: 5 to 100% of process scale range Set Point: Continuously adjustable from 0 to 100% of the scale range</p> <p>Steady-State Air Consumption⁽²⁾ 0 to 1.4 Bar (0 to 20 Psig) Output: 0.08 m³/hr (2.8 scfh) 0 to 2.4 Bar (0 to 35 Psig) Output: 0.07 m³/hr (2.5 scfh)</p> <p>Operative Ambient Temperature Limits⁽³⁾ -40 to 70°C (-40 to 160°F)</p> <p>Housing Designed to NEMA 3 (weatherproof) and IEC 529 IP54 specifications</p> <p>Hazardous Area Classification 4194S differential pressure indicating controllers comply with the requirements of ATEX Group II Category 2 Gas and Dust</p> <p> II 2 G D Ex h IIC Tx Gb Ex h IIIC Tx Db</p> <p>Maximum surface temperature (Tx) depends on operating conditions Gas: T6 Dust: T70</p> <p>Mounting Controller can be mounted on actuator, panel, wall, or pipestand.</p>
---	--

-Continued-

Table 1-1. Specifications (continued)

<p>Available Configurations</p> <p>Approximate Weight 4.5 kg (10 pounds)</p> <p>Declaration of SEP Fisher Controls International LLC declares this product to be in compliance with Article 4 paragraph</p>	<p>3 of the PED Directive 2014/68/EU. It was designed and manufactured in accordance with Sound Engineering Practice (SEP) and cannot bear the CE marking related to PED compliance.</p> <p>However, the product <i>may</i> bear the CE marking to indicate compliance with <i>other</i> applicable European Community Directives.</p>
--	--

NOTE: Specialized instrument terms are defined in ANSI/ISA Standard 51.1 - Process Instrument Terminology.
 1. Consult your Emerson sales office for additional information.
 2. Normal m3/hour - Normal cubic meters per hour at 0°C and 1.01325 bar, absolute. Scfh - Standard cubic feet per hour at 60°F and 14.7 psia
 3. Also for transportation and storage limits.

Table 1-2. Available Configurations for Fisher 4194S Controllers

CONTROLLER ⁽¹⁾	OPTIONS	
	Internal Auto/Manual Station, Option E	Remote Set Point, Option M
4194S		
4194SE	X	
4194SM		X
4194SME	X	X

1. Reverse-acting constructions are designated by an R added to the type number

Table 1-3. Process Sensor (Capsular Element) Pressure Ratings and Materials

UNITS	CAPSULAR STANDARD RANGES	DIFFERENTIAL SPAN		UNITS	STATIC PRESSURE OPERATING RANGE		OPERATING LIMIT ⁽³⁾	STANDARD MATERIAL
		Minimum ⁽¹⁾	Maximum ⁽²⁾		Minimum Inches of Mercury (bar)	Maximum		
Bar	0 to 4.0	0.2	0.4	Bar	-0.4	0.4	0.5	N09902
	0 to 0.7	0.4	0.7		-.07	0.7	1.0	
	0 to 1.4	0.7	1.4		-1.0	1.4	2.1	
	0 to 2.0	1.0	2.0		-1.0	2.0	3.1	
Psid	0 to 5	2.5	5	Psig	-10	5	7.5	
	0 to 10	5.0	10		-20	10	15.0	
	0 to 20	10.0	15		-30	20	30.0	
	0 to 30	15.0	20		-30	30	45.0	

1. Span is adjustable between minimum shown and maximum of the capsular element operating range and can be positioned anywhere within this range. For example, if a 0 to 2.0 bar (0 to 30 psid) capsular element is used and the minimum span of 1.0 bar (15 psid), 1.0 to 2.0 bar (15 to 30 psid), or any value between minimum and maximum value of the operating range.
 2. Maximum difference between the two input supply pressures.
 3. Capsular element may be pressured to this value (after reaching travel stop at upper range limit) without permanent zero shift or structural damage to controller components.

Table 1-4. Supply Pressure Data

OUTPUT SIGNAL RANGE	NORMAL OPERATING SUPPLY PRESSURE ⁽¹⁾	MAXIMUM PRESSURE TO PREVENT INTERNAL DAMAGE ⁽²⁾
Bar	0 & 1.4	2.8
	0 & 2.4	2.8
Psig	0 & 20	40
	0 & 35	40

1. If this pressure is exceeded, control stability may be impaired.
 2. If this pressure is exceeded, damage to the controller may result.

Specifications

⚠ WARNING

This product is intended for a specific current range, temperature range and other application specifications. Applying different current, temperature and other service conditions could result in malfunction of the product, property damage or personal injury.

Specifications for 4194S controllers are listed in table 1-1.

Educational Services

Emerson Automation Solutions
Educational Services - Registration
Phone: +1-800-338-8158
E-mail: education@emerson.com
emerson.com/mytraining

Section 2 Installation

The controllers should be mounted with the housing vertical (as shown in figure 2-1) so that the vent points down.

⚠ WARNING

To avoid personal injury or property damage from sudden release of process pressure:

- Always wear protective clothing, gloves, and eyewear when performing installation and maintenance procedures.
- Personal injury or property damage may result from fire or explosion if natural gas is used as the supply medium and preventive measures are not taken. Preventive measures may include, but are not limited to, one or more of the following: Remote venting of the unit, re-evaluating the hazardous area classification, ensuring adequate ventilation, and the removal of any ignition sources. For information on remote venting of this controller, refer to page 10.
- Check with your process or safety engineer for any additional measures that must be taken to protect against process media.
- If installing into an existing application, also refer to the WARNING at the beginning of the Maintenance section in this instruction manual.

NOTICE

Do not use sealing tape on pneumatic connections. This instrument contains small passages that may become obstructed by detached sealing tape. Thread sealant paste should be used to seal and lubricate pneumatic threaded connections.

Actuator Mounting

Refer to figure 2-1. Controllers specified for mounting on a control valve actuator will be mounted at the factory. If the controller is ordered separately for installation on a control valve actuator, mount the unit as described in this section. Mounting parts vary for different actuator types.

Attach the mounting bracket to the actuator yoke with cap screws, lock washers, and spacer spools. Attach the controller to the bracket with cap screws, lock washers, and spacer spools. On some designs, the mounting bracket is attached to the actuator casing rather than to the yoke.

Panel Mounting

Refer to figure 2-2. Cut a hole in the panel surface using the dimensions shown in figure 2-2. Slide the controller into the hole and attach the bracket (key 68) to the rear of the controller using three cap screws (key 66) and lock washers (key 67). Tighten the screws (key 70) to draw the case snugly and evenly to the panel surface.

Wall Mounting

Refer to figure 2-3. Drill holes in the wall (using the dimensions in figure 2-3) to align with the four holes in the bracket (key 68). If the process tubing is to run through the wall, drill a hole in the wall large enough to accept the tubing.

Mount the controller to the bracket using three cap screws (key 66) and lock washers (key 67). Attach the bracket to the wall, using suitable screws or bolts.

Pipestand Mounting

Refer to figure 2-4. Pipestand mounting parts are provided to mount the controller to an NPS 2 (nominal) pipe. Attach a bracket (key 68) to the controller with cap screws (key 66) and lock washers (key 67). Attach two clamps (key 69) to the bracket, and fasten the controller to the pipe.

Figure 2-1. Typical Actuator Mounting

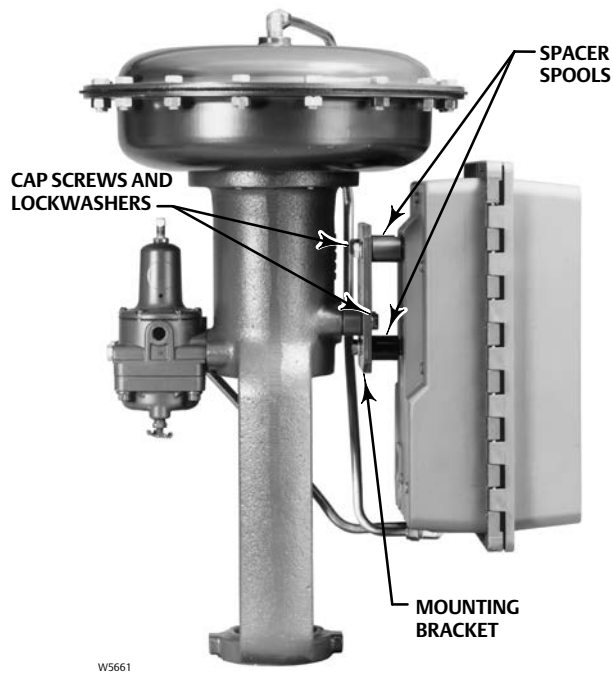

Figure 2-3. Wall Mounting

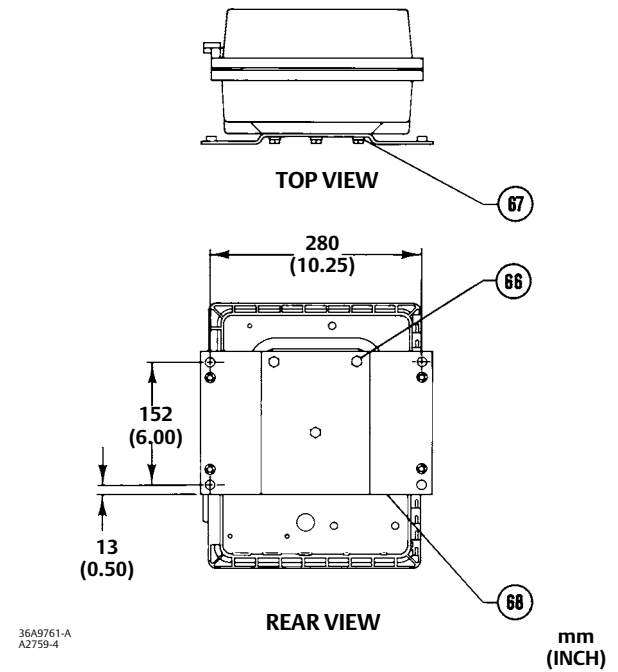

Figure 2-2. Panel Mounting

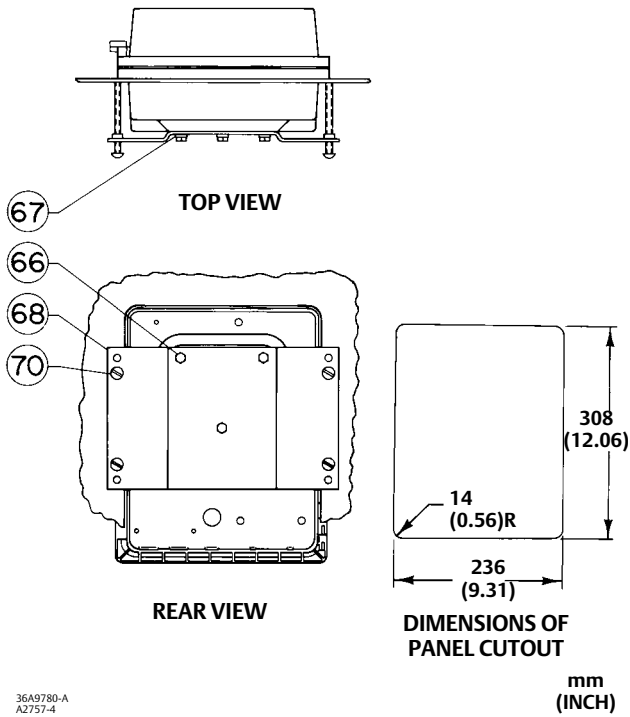
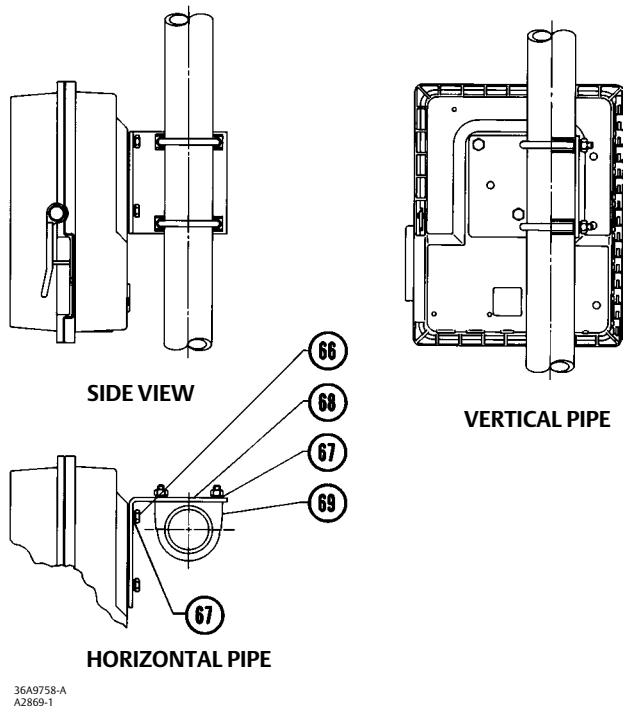

Figure 2-4. Pipestand Mounting



Pressure Connections

⚠ WARNING

Overpressuring any system component, including the capsular sensing element, could result in personal injury or property damage due to fire and explosion caused by venting or leakage of a hazardous supply pressure medium or process medium. To avoid such injury or damage, provide suitable pressure-relieving or pressure-limiting devices if supply pressure or process pressure is capable of exceeding the maximum allowable pressures in tables 1-3 and 1-4.

NOTICE

Do not use sealing tape on pneumatic connections. This instrument contains small passages that may become obstructed by detached sealing tape. Thread sealant paste should be used to seal and lubricate pneumatic threaded connections.

Refer to figure 2-5. Supply, output, and vent connections are 1/4 NPT. Process pressure connections are 1/4 or 1/2 NPT (optional).

Figure 2-5. Location of Connections

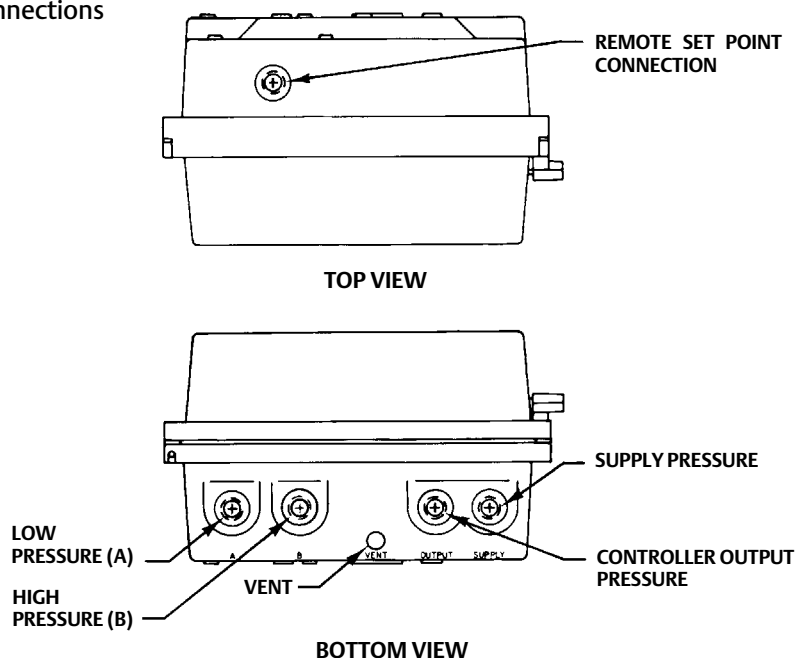

Process Pressure

Process pressure is piped to the connection marked A and B on the bottom of the case (see figure 2-5). The high pressure line is piped to connection B, and the low pressure line connects to A.

When installing process piping, follow accepted practices to ensure accurate transmission of the process pressure to the controller. Install shutoff valves, vents, drains, or seal systems as needed in the process pressure lines.

If the instrument is located such that the adjacent process pressure line will be approximately horizontal, the line should slope downward to the instrument for liquid-filled lines and upward toward the instrument for gas-filled lines. This will minimize the possibility of air becoming trapped in the sensor with liquid-filled lines or of condensate becoming trapped with gas-filled lines. The recommended slope is 80 millimeters per meter (1 inch per foot).

Supply Pressure

⚠ WARNING

Severe personal injury or property damage may occur if the instrument air supply is not clean, dry and oil-free, or noncorrosive gas. While use and regular maintenance of a filter that removes particles larger than 40 micrometers in diameter will suffice in most applications, check with an Emerson field office and industry instrument air quality standards for use with corrosive gas or if you are unsure about the proper amount or method of air filtration or filter maintenance.

Supply pressure medium must be clean, dry, and noncorrosive and meet the requirements of ISA Standard 7.0.01 or ISO 8573-1. A maximum 40 micrometer particle size in the air system is acceptable. Further filtration down to 5 micrometer particle size is recommended. Lubricant content is not to exceed 1 ppm weight (w/w) or volume (v/v) basis. Condensation in the supply medium should be minimized.

Use a suitable supply pressure regulator to reduce the supply pressure source to 1.4 bar (20 psig) for an output signal range of 0 and 1.4 bar (0 and 20 psig) and to 2.4 bar (35 psig) for an output signal range of 0 and 2.4 bar (0 and 35 psig).

Remote Set Point Pressure (Option M)

If the controller has the remote set point option, connect the remote set point pressure to the top of the controller case at the location shown in figure 2-5. Use a clean dry air supply.

Vent

⚠ WARNING

Personal injury or property damage could result from fire or explosion of accumulated gas, or from contact with hazardous gas, if a flammable or hazardous gas is used as the supply pressure medium. Because the controller case and cover assembly do not form a gas-tight seal when the assembly is enclosed, a remote vent line, adequate ventilation, and necessary safety measures should be used to prevent the accumulation of flammable or hazardous gas. However, a remote vent pipe alone cannot be relied upon to remove all flammable or hazardous gas. Vent line piping should comply with local and regional codes and should be as short as possible with adequate inside diameter and few bends to reduce case pressure buildup.

NOTICE

When installing a remote vent pipe, take care not to overtighten the pipe in the vent connection. Excessive torque will damage the threads in the connection.

If a remote vent is required, the vent line must be as short possible with a minimum number of bends and elbows. Vent line piping should have a minimum inside diameter of 19 mm (3/4 inches) for runs up to 6.1 m (20 feet) and a minimum inside diameter of 25 mm (1 inch) for runs from 6.1 to 30.5 m (20 to 100 feet).

If a remote vent is not required, the vent opening (figure 2-5) must be protected against the entrance of any foreign material that could plug it. Check the vent periodically to be certain it is not plugged.

Section 3 Controller Operation

Operating Information

This section includes descriptions of adjustments and procedures for prostrate and startup procedures. Location of adjustments are shown in figures 3-1 and 3-2. To better understand the adjustments and overall operation of the controller, refer to the Principle of Operation section and the schematic diagrams, figures 3-4 and 3-5.

Adjustments

Manual Set Point

To adjust the set point, open the controller cover and move the set point adjustment until the pointer indicates the desired value of pressure on the process pressure scale. Move the adjustment to the right to increase the set point, and to the left to decrease it. Adjusting the set point does not affect the differential gap setting.

Remote Set Point (Option M)

NOTICE

Do not move the set point adjustment manually on controllers equipped with remote set point. Doing so could damage the controller.

If the controller is equipped with the remote set point option (see figure 3-2), vary the remote set point pressure to change the set point. Increase the pressure to increase the set point, and decrease the pressure to decrease the set point.

Proportional Band (Differential Gap)

The proportional band knob adjusts the width of the gap between switching points. Rotate the proportional band knob until the desired setting is opposite the line on the proportional band indicator cover.

Changing Controller Action

Controller action can be switched from direct to reverse or vice versa by simply loosening the screws on the proportional band indicator cover and moving the cover out so the proportional band knob can be rotated to the desired action. The white portion of the adjustment enables direct controller action; the black portion enables reverse controller action.

Auto/Manual Switching (Option E)

Refer to figure 5-4 if the controller has the auto/manual option. Two balance methods are available to equalize the manual output with the controller pressure. To switch from automatic to manual mode, carefully adjust the loader knob until the metal ball inside the plastic tube moves into the switching zone. Then move the automatic/manual switch to MANUAL. Turn the loader knob clockwise to increase the controller output or counter-clockwise to decrease it. To switch from manual to automatic mode, adjust the set point manually or with remote set point pressure to move the ball into the switching zone. Turn the switch to AUTOMATIC, and move the set point adjustment to control the output.

When the automatic/manual switch is in AUTOMATIC, adjusting the loader knob has no effect on the controller output. When the automatic/manual switch is in MANUAL, changing the set point adjustment has no effect on the controller output.

NOTICE

Switching the controller between automatic and manual mode without balancing can disturb the process and cause controller cycling.

Prestartup Checks

When performing the checks, open loop conditions must exist. Refer to figure 3-1 for location of adjustments.

Note

If the controller has the auto/manual option (option E), be sure the controller is in the automatic mode prior to performing prestartup checks.

Figure 3-1. Location of Controller Parts and Adjustments

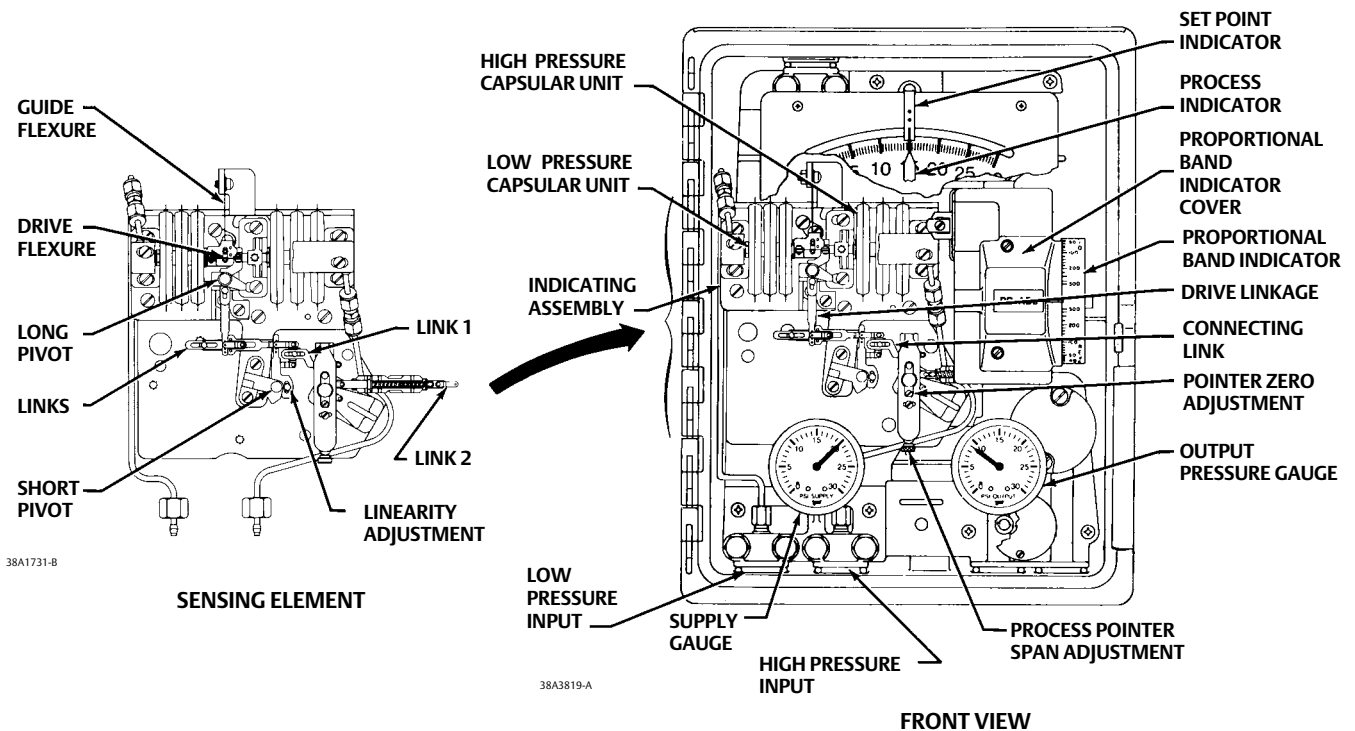
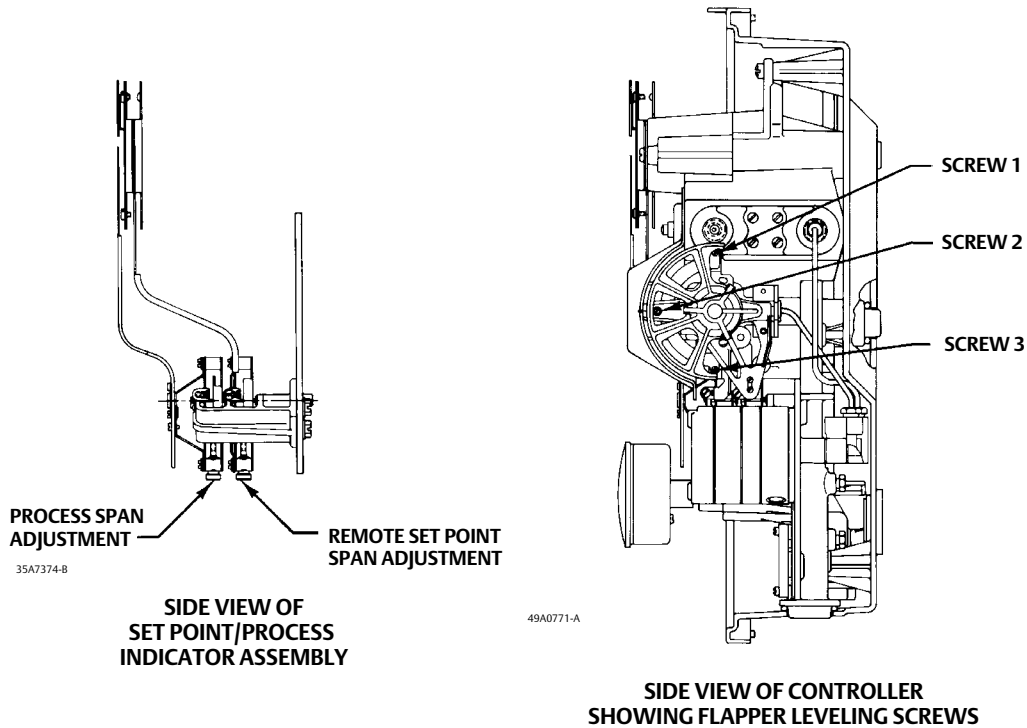

Figure 3-1. Location of Controller Parts and Adjustments (continued)



C0541

1. Connect supply pressure to the supply pressure regulator, and be sure it is delivering the proper supply pressure to the controller. Provide a means of measuring the controller output pressure.
2. For controllers with remote set point (option M), connect regulated pressure of 0.2 to 1.0 bar (3 to 15 psig) or 0.4 to 2.1 bar (6 to 30 psig) to the remote set point connection at the top of the controller case.
3. Loosen two screws (key 6), lift off the proportional band cover (key 36), and set the proportional band knob between DIRECT and REVERSE.

The process indicator should indicate the process differential pressure. For example, with the process differential pressure at 50 percent of the input span, the process pointer should be at 50 ± 1.0 percent of its span. Slight adjustment of the indicator zero screw may be necessary. See figure 3-1 for zero adjustment and locking screw location.

4. If desired, the accuracy can be verified at other points on the scale. If the indicator appears to be out of calibration, refer to the process zero and span adjustment portion of the calibration procedure.

Startup

It is recommended that the controller switching points be set as described in the calibration procedures.

Slowly open the upstream and downstream manual control valves in the pipeline and close the manual bypass valve if they are used.

Calibration

⚠ WARNING

To avoid personal injury or property damage resulting from the sudden release of pressure, do not exceed the operating limits given in this manual.

If the prestartup checks revealed faulty adjustment of the process indicator, perform the calibration procedures. These procedures are valid for either shop or field calibration, provided that open process loop conditions exist.

Note

If the controller has the auto/manual option, be sure the controller is in the automatic mode prior to performing the calibration procedure.

Process Zero and Span Adjustment

Note

Any adjustment of the pointer span adjustment screw will require readjustment of the pointer zero adjustment screw.

1. Refer to figure 3-1 for location of adjustments.
2. Remove the two screws (key 6) and lift off the proportional band indicator cover (key 36).
3. Set the proportional band between DIRECT and REVERSE.
4. Adjust the process differential pressure to the low limit of the input range.
5. Adjust the process pointer to the lowest limit of the input scale by loosening the zero adjustment locking screw and turning the zero adjustment screw.
6. Adjust the process differential pressure to the upper limit of the input span. Note whether the pointer indication is above or below the upper limit of the process scale.
7. Adjust the span screw as follows: Clockwise to increase span for a low indication; counterclockwise to decrease span for a high indication. Adjust the span screw to correct one-half the error.
8. Repeat steps 4 through 7 until the error is eliminated.
9. Turn the proportional band indicator knob to 400 percent in the desired controller action (either DIRECT or REVERSE).
10. Install the proportional band indicator cover (key 36) and tighten the two screws (key 6).

Remote Set Point Zero and Span Adjustment (Option M)

Note

Any adjustment of the pointer span adjustment screw will require readjustment of the pointer zero adjustment screw.

1. Refer to figures 3-1 and 3-2 for location of adjustments.
2. Remove the two screws (key 6) and lift off the proportional band indicator cover (key 36).
3. Set the proportional band between DIRECT and REVERSE.
4. Adjust the set point pressure to the low limit of the input range.
5. Adjust the set point indicator to the lowest limit of the input scale by loosening the zero adjustment locking screw and turning the zero adjustment screw.
6. Adjust the set point pressure to the upper limit of the input span. Note whether the pointer indication is above or below the upper limit of the process scale.
7. Adjust the span screw as follows: clockwise to increase span for a low indication; counterclockwise to decrease span for a high indication. Adjust the span screw to correct one-half the error.
8. Repeat steps 4 through 7 until the error is eliminated.
9. Replace the proportional band indicator cover (key 36), and tighten the two screws (key 6).

Figure 3-2. Location of Controller Parts and Adjustments (Remote Set Point Option)

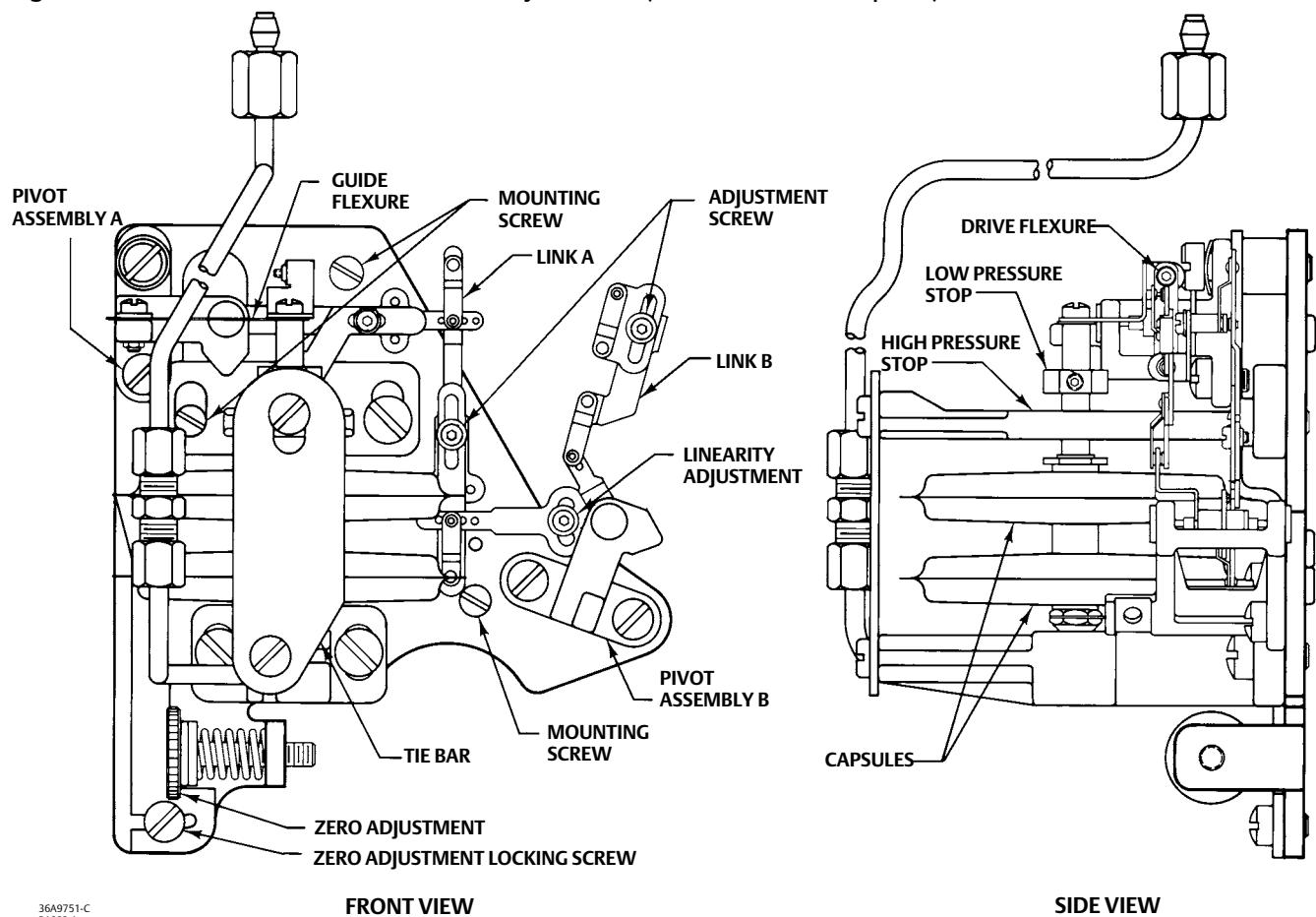

Setting Switching Points

Direct-Acting Controllers

The controller output signal will switch from zero pressure to full supply pressure when increasing process pressure passes the upper switching point.

The controller output signal will not return to zero pressure until decreasing process pressure passes the lower switching point. When making adjustments as described in the following steps, keep in mind that:

- Changing the set point adjustment will move both switching points equally in the direction of adjustment.
- Changing the proportional band adjustment will widen or narrow the differential gap between the two switching points by moving the position of the lower switching point.

Figure 3-3 shows the relationship between the percent of sensor range between switching points and the proportional band setting on the controller. The following example illustrates how to use figure 3-3.

Example: The sensing element has a range of 30 psi. The lower switching point is to be set at 10 psi and the upper switching point is to be set at 25 psi.

Proceed as follows:

- Divide the differential gap (the difference between the upper and lower switching points) by the sensing element range. Multiply the result by 100 as shown in the following equation:

$$\frac{\text{Differential Gap}}{\text{Sensing Element Range}} \times 100 = \frac{15 \text{ psi}}{30 \text{ psi}} \times 100 = 50\%$$

- Locate the 50 percent line on figure 3-3. Move along this line until you intersect the curve. Read the proportional band setting on the left hand axis. For this example, the setting is approximately 35 percent.

Figure 3-3. Curve for Determining Proportional Band Setting

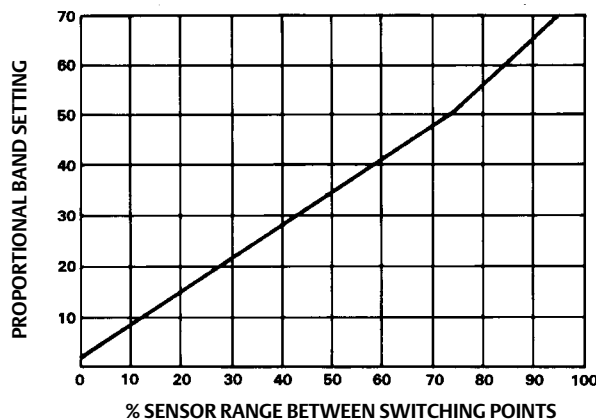

A2853-1

1. Using the curve in figure 3-3, determine the correct proportional band setting for the desired gap (expressed as a percent of the input span) between the switching points.
2. Set the proportional band knob to the desired setting determined in step 1.
3. Adjust the set point to the desired upper switching point.
4. Increase the process differential pressure until the controller output signal switches from zero pressure to full supply pressure.
5. Decrease the process differential pressure to the desired switching point at which the controller output signal switches from full supply pressure to zero pressure.

6. Narrow the proportional band slowly until the output signal switches from zero pressure to full supply pressure.
7. Repeat steps 4 through 6 until the controller output switches at the desired points.
8. Observe the process pointer when the output switches at the upper switching point. The process pointer indication should be within ± 2 percent of the set point indication. If the output does not snap within ± 2 percent of set point, refer to the calibration procedures.

Reverse-Acting Controllers

The controller output signal will switch from zero pressure to full supply pressure when decreasing process pressure passes the lower switching point.

The controller output signal will not return to zero pressure until increasing process pressure passes the upper switching point. When making adjustments as described in the following steps, keep in mind that:

- Changing the set point adjustment will move both switching points equally in the direction of adjustment.
- Changing the proportional band adjustment will widen or narrow the differential gap between the two switching points by moving the position of the upper switching point.

Figure 3-3 shows the relationship between the percent of sensor range between switching points and the proportional band setting on the controller. The following example illustrates how to use figure 3-3.

Example: The sensing element has a range of 30 psi. The lower switching point is to be set at 10 psi and the upper switching point is to be set at 25 psi.

Proceed as follows:

- Divide the differential gap (the difference between the upper and lower switching points) by the sensing element range. Multiply the result by 100 as shown in the following equation.

$$\frac{\text{Differential Gap}}{\text{Sensing Element Range}} \times 100 = \frac{15 \text{ psi}}{30 \text{ psi}} \times 100 = 50\%$$

- Locate the 50 percent line on figure 3-3. Move along this line until you intersect the curve. Read the proportional band setting on the left hand axis. For this example, the setting is approximately 35 percent.
1. Using the curve in figure 3-3, determine the correct proportional band setting for the desired gap (expressed as a percent of the maximum input element span) between the switching points.
 2. Set the proportional band knob to the desired setting determined in step 1.
 3. Adjust the set point to the desired lower switching point.
 4. Carefully adjust the process differential pressure to 100 percent of scale range. Then, decrease the process differential pressure until the controller output signal switches from zero pressure to full supply pressure.
 5. Increase the process differential pressure to the desired switching point at which the controller output signal switches from full supply pressure to zero pressure.
 6. Widen the proportional band slowly until the output signal switches from zero pressure to full supply pressure.
 7. Repeat steps 4 through 6 until the controller output switches at desired points.
 8. Observe the process pointer when the output switches at the lower switching points. The process pointer indication should be within ± 2 percent of the set point indication. If the output does not snap within ± 2 percent of set point, refer to the calibration procedures.

Principle of Operation

Overall Operation

Refer to the schematic diagram in figure 3-4.

Figure 3-4. Schematic of Operation for Fisher 4195S Controllers

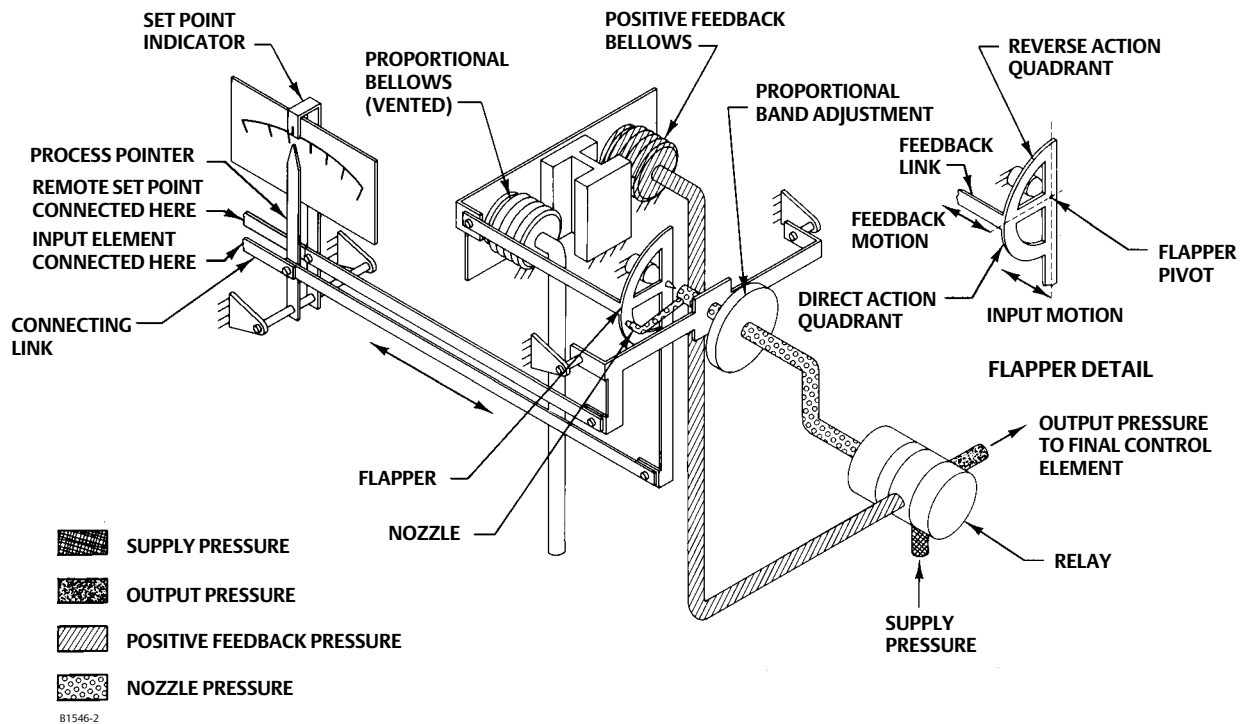

The input element is connected to the process pointer and to the flapper by connecting links. As the process pressure increases (in a direct-acting controller), the flapper moves toward the nozzle, restricting flow through the nozzle and increasing nozzle pressure. When this occurs, relay action increases the output pressure (delivery) of the controller. Output pressure is fed back to the positive feedback bellows. The action of this bellows is a positive feedback action that moves the flapper closer to the nozzle, increasing nozzle pressure, which in turn, increases the relay output. Output pressure to the final control element switches to full supply pressure.

As the process differential pressure decreases, approaching the lower switching point, the flapper moves away from the nozzle (in a direct-acting controller) reducing nozzle pressure. Through relay action, pressure to the positive feedback bellows is reduced, moving the flapper further away from the nozzle, and further reducing nozzle pressure. Output pressure to the final control element switches to zero.

The set point adjustment changes the proximity of the nozzle and flapper as does a change in process pressure except that, when the set point is changed, the nozzle moves with respect to the flapper. The set point adjustment moves both the upper and lower switching points.

The proportional band knob positions the nozzle on the flapper. Increasing (widening) the proportional band moves the nozzle away from the input connection. When the proportional band adjustment moves the nozzle across the feedback connection, the controller action changes between direct and reverse. On a direct-acting controller, changing the proportional band adjustment will widen or narrow the differential gap between the two switching points. This is accomplished by changing the position of the lower switching point. On a reverse-acting controller, changing the proportional band adjustment will widen or narrow the differential gap between the two switching points. This is accomplished by changing the position of the upper switching point.

Remote Set Point Option

The capability to adjust the controller set point from a remote location is available with all 4194S controllers. This option is designated by the letter M in the type number.

Auto/Manual Option

Controllers with the auto/manual option (designated by the letter E in the type number) have piping on the output side of the relay as shown in figure 3-5. Supply pressure to the relay is also applied to the manual loader. The manual loader, functioning as a regulator, applies pressure to one side of the plastic tube and to the auto/manual switch. Output pressure from the relay registers on the other side of the plastic tube as well as in the auto/manual switch.

When the auto/manual switch is in the MANUAL position, the output of the manual loader is channeled through the auto/manual switch and becomes the output of the controller. When the auto/manual switch is in the AUTO position, the output of the relay is channeled through the switch to become the output of the controller.

Before the auto/manual switch is operated, the output of the relay must equal the manual loader output to avoid bumping the process. Adjusting the set point varies the pressure on the left-hand side of the plastic tube. Adjusting the manual loader knob varies the pressure on the right-hand side of the tube. When the pressures are equal, the metal ball is centered in the tube. Pressure imbalance forces the ball to one end of the tube where it forms a seal, blocking air flow through the tube.

Figure 3-5. Schematic of Auto/Manual Option

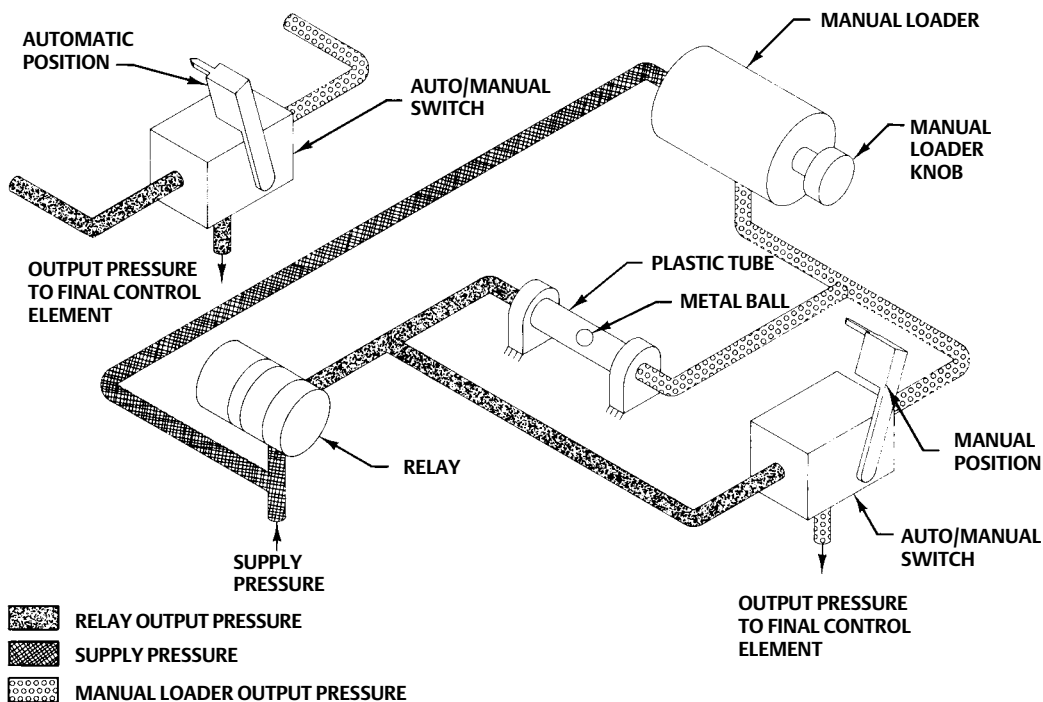

48A5230-A
A2999-1

Section 4 Maintenance

Parts are subject to normal wear and must be inspected and replaced as necessary. The frequency of inspection and parts replacement depends upon the severity of the service conditions. When inspection or repairs are required, disassemble only those parts necessary to accomplish the job. Figure 4-1 is a maintenance guide. It summarizes the information available in the maintenance procedures.

Select the appropriate maintenance procedure, and perform the numbered steps. Each procedure requires that supply pressure and process pressure be shut off before beginning maintenance.

When maintenance procedures, including Maintenance Calibration and Flapper Alignment, have been completed, refer to the appropriate prestartup portion in the controller operation procedure.

Note

Unless otherwise noted, key numbers refer to figure 5-1. Figures 3-1 and 3-2 show the location of adjustments and major components. For maintenance on the indicator assembly, refer to figure 5-6.

⚠ WARNING

The following maintenance procedures require taking the controller out of service. To avoid personal injury and property damage caused by uncontrolled process pressure, observe the following before performing any maintenance procedures:

- Always wear protective clothing, gloves, and eyewear when performing any maintenance procedures to avoid personal injury.
 - Personal injury or property damage may result from fire or explosion if natural gas is used as the supply medium and preventive measures are not taken. Preventive measures may include, but are not limited to, one or more of the following: Remote venting of the unit, re-evaluating the hazardous area classification, ensuring adequate ventilation, and the removal of any ignition sources. For information on remote venting of this controller, refer to page 10.
 - Provide temporary means of control for the process before taking the controller out of service.
 - Shut off the supply pressure to the controller.
 - Disconnect any operating lines providing supply air pressure, a process input signal, or other pressure source to the controller.
 - Check with your process or safety engineer for any additional measures that must be taken to protect against process media.
-

Figure 4-1. Maintenance Guide

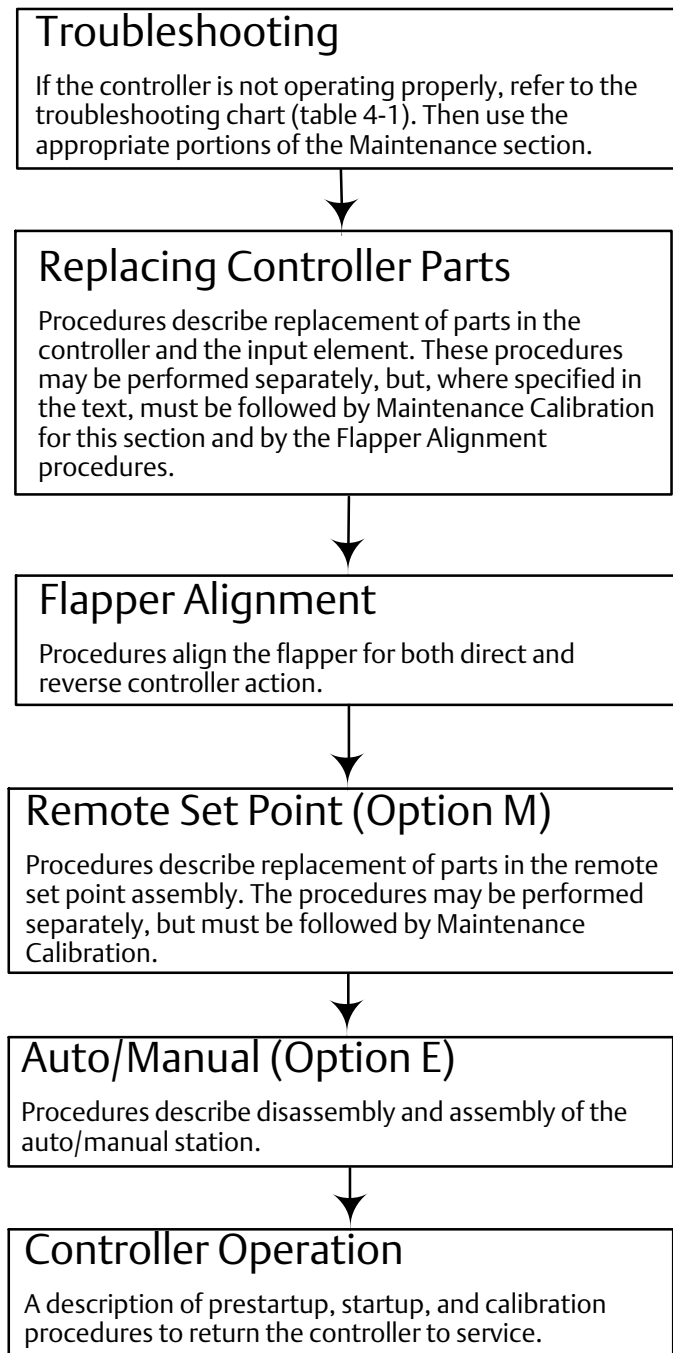

Troubleshooting

As an aid to troubleshooting, table 4-1 lists some common operating faults, their probable cause, and suggests procedures for correcting the fault.

Table 4-1. Troubleshooting Chart

Fault	Possible Cause	Check	Correction
1. Output does not snap when process pointer and set point indicator are aligned.	1.1 Flapper out of alignment 1.2 Process pointer not calibrated correctly 1.3 No supply pressure 1.4 Leak in nozzle or feedback tubing 1.5 Leak in relay O-rings	1.1 Refer to Flapper Alignment procedures 1.2 Refer to the Process Zero and Span Adjustment procedures 1.3 Check supply pressure 1.4 Using a soap solution, check for leaks 1.5 Using a soap solution, check for leaks	1.1 Align flapper as necessary 1.2 Adjust as necessary 1.3 Provide correct supply pressure 1.4 Repair or replace defective parts 1.5 Repair or replace defective O-rings
2. Controller output will not snap to full output pressure	2.1 Output pressure gauge not functioning 2.2 Supply pressure incorrect 2.3 Leak in positive feedback tubing 2.4 Leak in nozzle tubing assembly 2.5 Sensing element or linkage failure 2.6 Relay malfunction 2.7 Switching point has not been reached 2.8 Link 4 not adjusted correctly	2.1 Check output with external gauge 2.2 Check with an external source 2.3 Using soap solution, check for leaks 2.4 Using soap solution, check for leaks 2.5 Inspect element or linkage for damaged parts 2.6 Manually cap the nozzle output by pushing the flapper toward the nozzle. Output should go to supply pressure. 2.7 Refer to the Flapper Alignment or to the Setting Switching Points procedure ---	2.1 Replace gauge if necessary 2.2 Repair or replace pressure regulator if necessary 2.3 Replace defective parts as necessary 2.4 Replace defective parts as necessary 2.5 Repair or replace damaged parts 2.6 If output does not change as described, remove relay. Replace O-rings if necessary. Replace relay if necessary. 2.7 Make alignments and adjustments as necessary 2.8 Refer to the maintenance procedures for link adjustment
3. Controller output will not snap to zero pressure	3.1 Flapper out of alignment 3.2 Switching point has not been reached 3.3 Sensing element or linkage failure 3.4 Links 2, 3, and 4 defective 3.5 Relay malfunction or clogged nozzle	3.1 Refer to the Flapper Alignment procedure 3.2 Refer to the Setting Switching Points procedure 3.3 Inspect sensing element and linkage for damaged parts. Using soap solution, check for leaks. 3.4 Inspect links for loose screws and improper connections. Ensure links are not rubbing or catching on other parts. 3.5 Manually push the flapper away from the nozzle. The output should go to zero.	3.1 Align flapper as necessary 3.2 Adjust switching as necessary 3.3 Repair or replace faulty parts 3.4 Replace links as necessary 3.5 Replace the relay. If the output still does not go to zero, replace the nozzle pivot assembly

Changing Controller Action

The following steps describe changing controller action from direct (increasing process pressure produces increasing output pressure) to reverse (increasing process pressure produces decreasing output pressure or vice versa).

1. Loosen two screws (key 6) in the proportional band indicator cover (key 36). The screws need not be removed.
2. Lift the proportional band indicator cover as shown in figure 4-2.
3. Rotate the proportional band knob (key 25) to the desired controller action.
4. Install the proportional band indicator cover (key 36), and tighten the two screws (key 6).

Figure 4-2. Changing Controller Action



W3439

Replacing Common Controller Parts

⚠ WARNING

To avoid personal injury or property damage caused by the uncontrolled release of pressure, be sure any trapped process pressure is properly vented from the controller. Vent any supply pressure from the controller before disassembly.

⚠ WARNING

Refer to the Maintenance WARNING on page 21 before replacing any common controller parts.

Process Pressure Scale

NOTICE

To prevent inaccurate indication and operation, take care not to bend the process indicator or the set point adjustment while performing the following procedure.

1. Refer to figure 4-3. Adjust the set point adjustment manually or with the remote set point pressure to 50 percent of scale.
2. Remove four screws (key 37).
3. Slide the process scale (key 61) so that the top of the slot touches the set point adjustment. Deflect the lower portion of the slot, and carefully slide the scale upward and off, clearing the set point indicator as shown in figure 4-3.

4. To install the replacement scale, bend the lower part of the slot slightly so that the scale slides downward over the set point adjustment and under the process indicator.
5. Install and tighten the four screws on the scale.
6. A slight zero adjustment (see figure 3-1) may be necessary so that the process indicator aligns with the 0 mark on the scale. This procedure is described in the Zero and Span Adjustment portion of the Calibration procedures.

Figure 4-3. Changing the Scale



W3440

DEFLECT LOWER PORTION OF THE SLOT



W3492

AND LIFT THE SCALE UP AND OFF

Relay

1. Loosen the two captive screws that hold the relay (key 50) in place.
2. Tip the relay slightly toward the case to clear the output pressure gauge, and lift out the relay.
3. Make sure the replacement relay has three O-ring assemblies as shown in figure 4-4. The fourth port is for exhaust and does not require an O-ring.
4. Install the replacement relay, making sure the tabs on the relay (see figure 4-4), line up with the tab on the frame.
5. Tighten the two screws that hold the relay in place.

Figure 4-4. Relay Construction

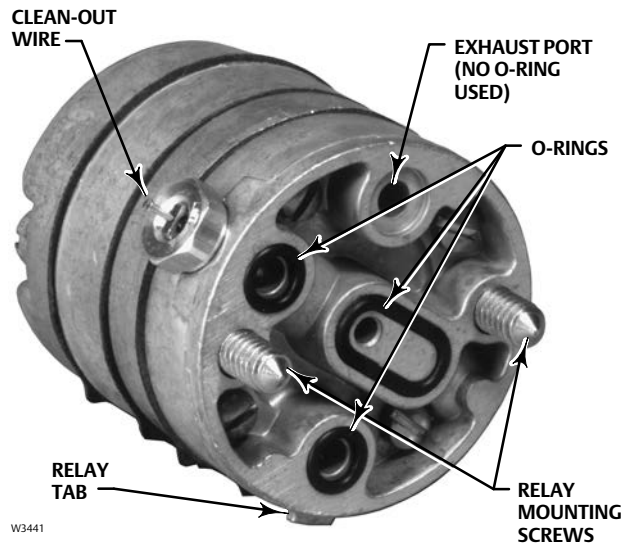

W3441

Case and Cover

NOTICE

The case and cover are an integral unit; attempting to separate them will damage the hinge. If the cover needs to be replaced, replace the case also.

1. Remove the supply and output piping from the controller. Bleed away any process pressure, and carefully remove the process pressure piping from the controller.
2. Remove the controller from its mounting (see the Installation section) to a maintenance area.
3. Remove the nine screws (key 38) from the case (key 1) and lift out the controller assembly.
4. Install the controller assembly in the replacement case.
5. Slide the controller frame down to assure an O-ring seal at the pressure connections. Hole the frame in place.
6. Install and tighten the nine mounting screws.
7. Remove the blow-out plug (key 72) from the original case, and install in the replacement case.
8. Mount the controller as described in the Installation section.
9. Connect the supply, output, and process pressure piping to the controller.

Gauges

NOTICE

Before performing this procedure, be sure the replacement gauges are the correct range so that the gauges are not damaged by overpressure.

1. Unscrew the output gauge (key 46) or the supply gauge (key 47) from the frame (key 3).
2. Before installing the replacement gauge, coat the threads on the gauge with a suitable sealant.
3. Screw the replacement gauge into the frame.

Pressure Control Block

1. Carefully remove the process pressure piping from the controller after bleeding away process pressure.
2. Loosen the nut on that portion of the tubing that connects the pressure sensing element to the pressure control block (key 57).
3. Remove the two cap screws (key 58) that hold the pressure control block to the frame (key 3), and lift out the pressure control block.
4. Install the O-ring (key 7) on the replacement pressure control block.
5. Install the replacement pressure control block to the frame with two screws (key 58).
6. Tighten the nut that was loosened in step 2.
7. Apply the process pressure equal to the maximum value on the process scale, and check for leaks.
8. Connect the process pressure piping to the controller.

Supply Tubing and Positive Feedback Tubing Assemblies

Note

The following procedure requires that the controller be removed from the case. Perform steps 1 through 3 of the replacing case and cover procedure.

1. Remove the nuts that hold the supply gauge tubing assembly (key 39) or the positive feedback tubing assembly (key 45) to the frame. Remove the tubing.
2. Install the replacement tubing assemblies.
3. Apply the correct supply pressure, and check for leaks.
4. Install the controller assembly in the case. Slide the controller frame down to assure an O-ring seal at the pressure connections. Hold the frame in place.
5. Install and tighten the nine self-tapping screws (key 38) into the frame.
6. Mount the controller as described in the Installation procedure.
7. Connect supply, output, and process pressure piping to controller.

Proportional Band Knob, Nozzle Pivot, and Set Point Beam Assembly

Note

The following procedure requires that the controller be removed from the case. Perform steps 1 through 3 of the replacing case and cover procedure.

1. Remove the two screws (key 6) and lift off the proportional band indicator cover (key 36) (figure 4-2).
2. Disconnect link number 3 from the set point beam assembly (key 23). Refer to figure 4-12 for location of the link.
3. Remove the set point beam bias spring (key 28). Refer to figure 4-5 for spring location.
4. Remove the screw and washer (keys 19 and 20) that hold the pivot assembly (key 17) to the frame, and remove the pivot assembly. Refer to figure 4-15.
5. Disconnect the nut that holds the relay nozzle tubing (key 18) into to the frame (key 3). Refer to figure 5-1.
6. While holding the proportional band knob, remove the screw and washer (keys 19 and 20) that hold the relay nozzle tubing assembly (key 18) to the frame.
7. Remove the proportional band knob nozzle pivot and the set point beam assembly from controller.
8. Remove the relay nozzle tubing assembly (key 18) from the set point beam assembly (key 23).
9. Remove the E-ring (key 27) from the nozzle assembly (key 21).
10. Remove the nozzle assembly (key 21) from the bottom of the set point beam assembly (key 23).
11. Remove the retaining clip (key 26).
12. Remove the proportional band knob (key 25) from the set point beam assembly (key 23).
13. Inspect the nozzle pivot O-ring.
14. Inspect the nozzle assembly (key 21), and replace if necessary. Inspect the nozzle orifice, and clean it if necessary.

15. Install the proportional band knob (key 25) on the set point beam assembly (key 23).
16. Install the retaining clip (key 26) on the three posts on the proportional band knob.
17. Install the nozzle assembly (key 21) through the set point beam assembly (key 23), the proportional band knob (key 25), and the retaining clip (key 26) into the cap, aligning the nozzle with the tab on the proportional band knob (shown in figure 4-5).
18. While holding the nozzle tubing (key 21) against the set point beam assembly (key 23), depress the retaining clip (key 26), and install the E-ring (key 27) into the E-ring groove on the nozzle tubing assembly (key 18).
19. Inspect the O-ring on the relay nozzle tubing assembly (key 18) and, replace it if necessary. Apply a suitable lubricant to the O-ring.
20. Install the relay nozzle tubing assembly (key 18) into the set point beam assembly.
21. Adjust the proportional band between DIRECT and REVERSE. Do this by aligning the tab on the proportional band knob with the hole in the set point beam assembly as shown in figure 4-6.
22. Position the proportional band knob, nozzle pivot and the set point beam assembly on the frame. Install the relay nozzle tubing nut loosely into frame manifold while positioning the nozzle in the center of the flapper as shown in figure 4-7.
23. Insert the screw and washer (keys 19 and 20) into the relay nozzle tubing assembly (key 18). Refer to figure 4-15.
24. Install the screw (key 19) through the frame (key 3) and into the relay nozzle tubing assembly (key 18). Tighten the screw and make sure the nozzle remains centered on the flapper with the set point beam assembly snugly against the relay nozzle tubing assembly.
25. Install the pivot of the set point pivot assembly (key 17) in the hole in the set point beam assembly (key 23).
26. Install the washer (key 20) on the screw (key 19).
27. Install the screw and washer (keys 19 and 20) through the frame (key 3) into the set point pivot assembly (key 23). Do not tighten.
28. First, slide the beam assembly snugly toward the relay tubing assembly; then, slide the set point pivot assembly (key 17) toward the set point beam until the cone lightly contacts the set point beam, and tighten the screw. The proportional band knob should fall freely when the controller is in the upright position. If it does not, reposition the set point pivot assembly (key 17) until the proportional band knob falls freely.
29. Tighten the nut on the relay nozzle tubing assembly (key 18), apply supply full pressure, and check for leaks. Disconnect supply pressure.
30. Install the set point beam bias spring (key 28) into the frame bore and onto the spring seat on the set point beam assembly (see figure 4-5).
31. Attach link number 3 to the set point assembly (key 23). See figure 4-12.
32. If the position of the set point beam shoe (see figure 4-5) was changed relative to the set point beam assembly (key 23) go to step 33. If the position of the set point beam shoe was not changed, go to step 53.
33. Connect supply pressure and regulated process differential pressure to the controller. Also, provide a means of measuring controller output pressure.
34. Perform the procedures. Then, proceed as directed by the following note.

Note

For direct-acting controllers, go to step 35. For reverse-acting controllers, go to step 44.

Figure 4-5. Proportional Band Adjustment and Set Point Beam Details

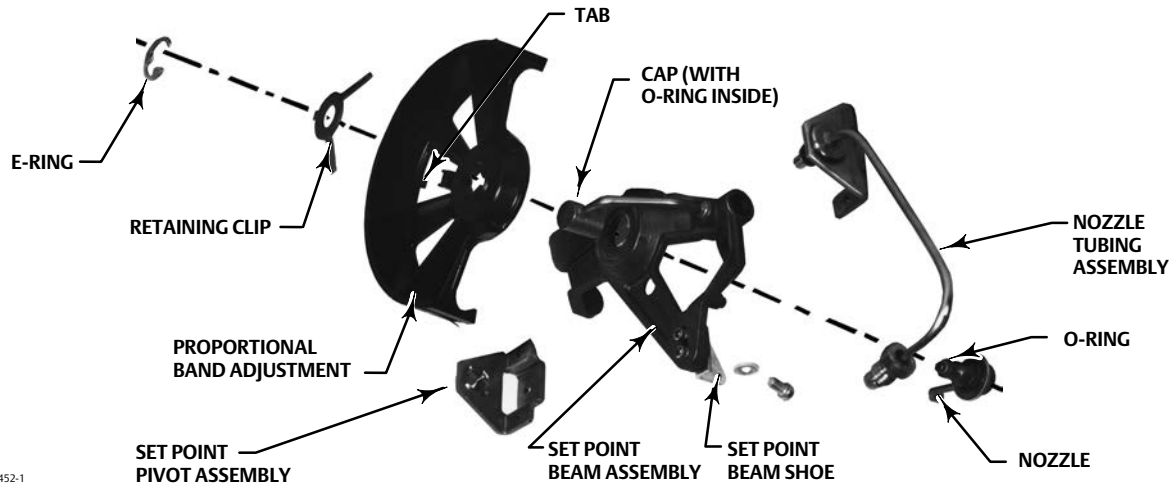

W3452-1

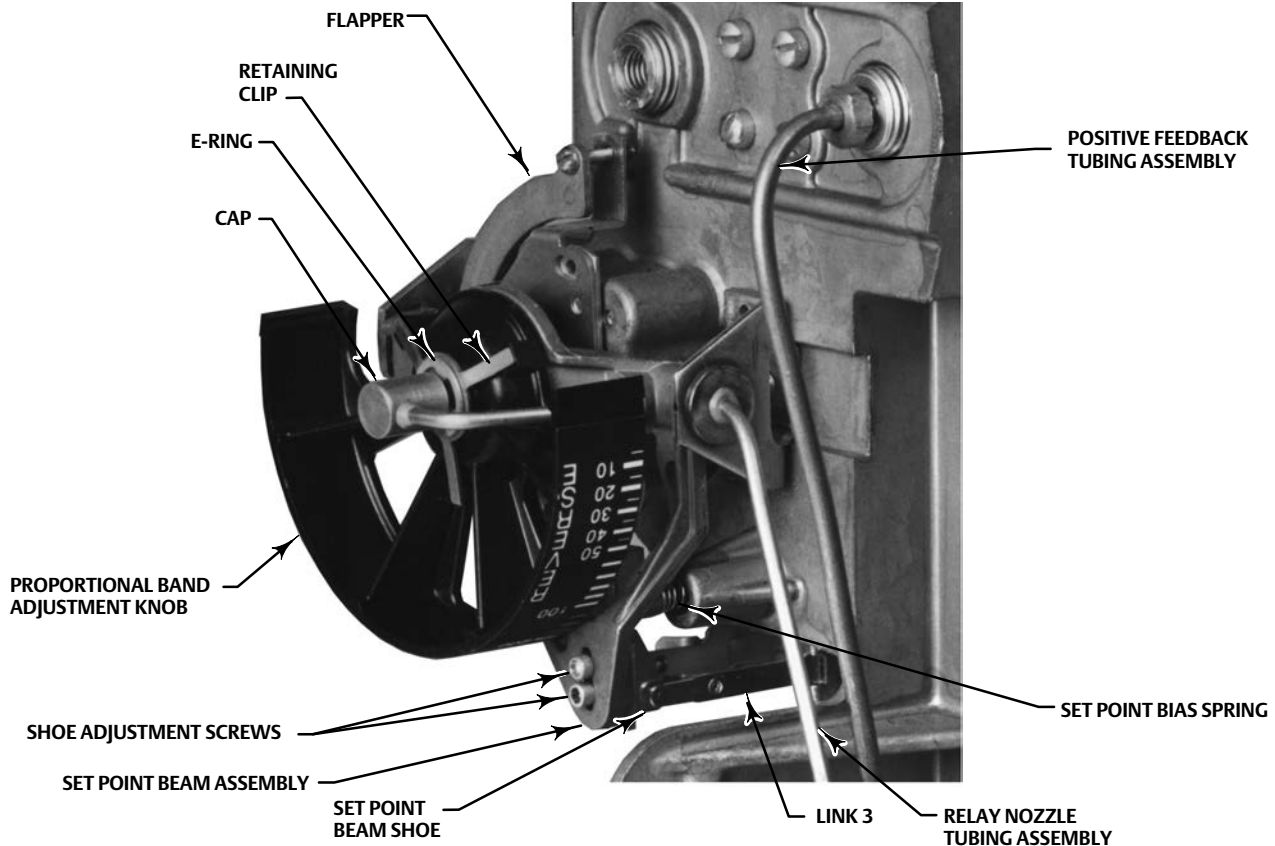

W3852

Figure 4-6. Proportional Band Adjustment Knob Setting

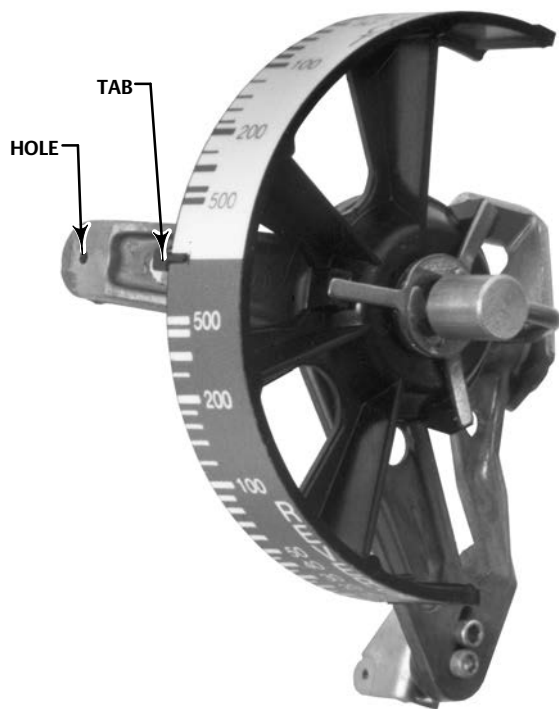

W3761

Figure 4-7. Nozzle-Flapper Positioning

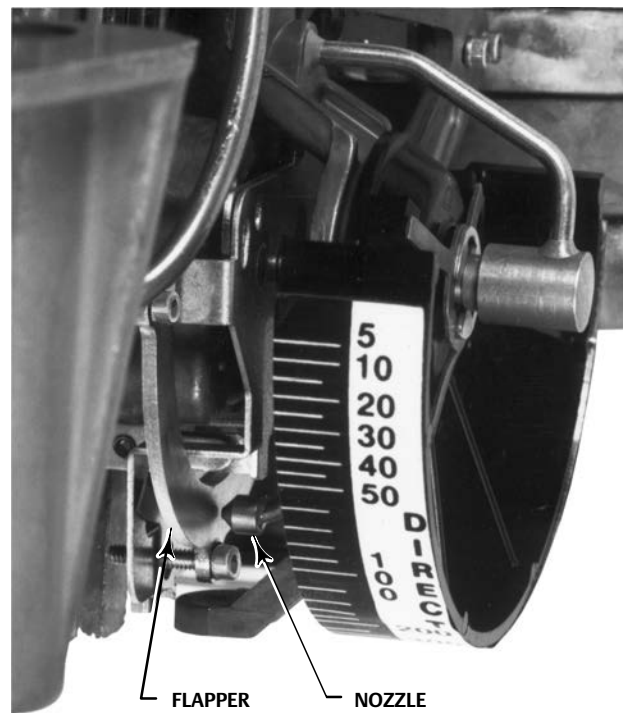

W3449

35. For direct acting controllers, adjust the proportional band knob to 5 percent direct acting. Adjust the set point adjustment or with remote set point pressure to 5 percent of the process scale range.

⚠ WARNING

In step 36, do not exceed the operating limits of the controller (refer to table 1-3). Personal injury or equipment damage may result from overpressure.

36. Slowly increase the process differential pressure from zero until the output pressure snaps to supply pressure. The output pressure should snap to supply pressure within ± 2 percent of set point.
37. If the output pressure snaps to supply pressure below 2 percent of set point, adjust flapper leveling screw number 3 clockwise (see figure 3-1 for location of screw). If the output pressure snaps to supply pressure above 2 percent of set point, adjust flapper leveling screw number 3 counterclockwise.
38. Repeat steps 36 and 37 until the output pressure snaps within ± 2 percent. If the tolerance cannot be obtained with the flapper leveling screw, go to step 42.
39. Adjust the set point manually or with remote set point pressure to 95 percent of the process scale range.
40. If the output pressure is not 0 psi, decrease the process differential pressure until the output pressure snaps to zero. Then slowly increase the process differential pressure until the output snaps to supply pressure. The output should snap to supply pressure within ± 2 percent of set point.
41. If the output pressure snaps to supply pressure within ± 2 percent of set point, go to step 53. If the output pressure does not snap to supply pressure within ± 2 percent of set point, go to step 42.
42. If the output pressure snaps to supply pressure below 2 percent of set point, adjust the set point beam shoe (key 29) slightly toward the center of the nozzle pivot. If the output snaps to supply pressure above 2 percent of set point, adjust the set point beam shoe slightly away from the center of the pivot.

43. Repeat steps 35 through 42 until the output pressure snaps to supply pressure within ± 2 percent of set point at 5 and 95 percent on the process scale range. Then go to step 53.
44. For reverse acting controllers, adjust the proportional band knob to 5 percent reverse acting. Adjust the set point manually or with remote set point pressure to 5 percent of the process scale range.
45. Carefully adjust the process differential pressure to 100 percent of the process scale range. Then, slowly decrease the process differential pressure until the output pressure snaps to supply pressure. The output should snap to supply pressure within ± 2 percent of set point.
46. If the output pressure snaps to supply pressure below 2 percent of set point, adjust flapper leveling screw number 1 counterclockwise (see figure 3-1 for location of screw). If the output pressure snaps to supply pressure above 2 percent of set point, adjust flapper leveling screw number 1 clockwise.
47. Repeat steps 44 through 46 until the output pressure snaps to supply pressure within ± 2 percent of set point. If the tolerance cannot be obtained with the flapper leveling screw, go to step 51.
48. Adjust the set point manually or with remote set point pressure to 95 percent to the process scale range.

⚠ WARNING

In step 49, do not exceed the operating limits of the controller (refer to table 1-3). Personal injury or equipment damage may result from overpressure.

49. Increase the process differential pressure until the output pressure snaps to zero. Then, slowly decrease the process differential pressure until the output pressure snaps to supply pressure. The output should snap to supply pressure within ± 2 percent of set point.
50. If the output pressure snaps to supply pressure within ± 2 percent of set point, go to step 53. If the output pressure does not snap to supply pressure within ± 2 percent, go to step 51.
51. If the output pressure snaps to supply pressure below 2 percent of set point, adjust the set point beam shoe (key 29) slightly toward the center of the nozzle pivot. If the output pressure snaps to supply pressure above 2 percent of set point adjust the set point beam shoe slightly away from the center of the nozzle pivot.
52. Repeat steps 44 through 51 until the output pressure snaps to supply pressure within ± 2 percent of set point at 5 and 95 percent of the process scale range; then go to step 53.
53. Install the controller assembly in the case. Slide the controller frame down to assure an O-ring seal at the pressure connections. Hold the frame in place.
54. Install and tighten the nine mounting screws that hold the controller assembly in place.
55. Refer to the Flapper Alignment procedures.
56. Replace the proportional band indicator cover (key 36) and tighten the two screws (key 6).

Flapper Flexure Pivot Assembly

Note

The following procedure requires that the controller be removed from the case. Perform steps 1 through 3 of the replacing case and cover procedure.

1. Remove the two screws (key 6), and lift off the proportional band cover (key 36).
2. Disconnect link number 3 from the set point beam assembly (key 23). Refer to figure 4-12 for link location.
3. Remove the set point beam bias spring (key 28), refer to figure 4-5 for spring location.

4. Remove the screw and washer (keys 19 and 20) that hold the adjustable set point pivot assembly (key 17) to the frame.
5. Remove the set point pivot assembly (key 17).
6. Disconnect the nut that secures the relay nozzle tubing (key 18) into the frame (key 3).
7. While holding the proportional band knob, remove the screw and washer (keys 19 and 20) that hold the relay nozzle tubing assembly (key 18) to the frame.
8. Remove the proportional band knob nozzle pivot and set point beam assembly from controller.
9. Disconnect link number 2 from the input feedback beam assembly (key 11) shown in figure 4-8. Refer to figure 4-12 for location of the link.

Figure 4-8. Leveling Screw Alignment

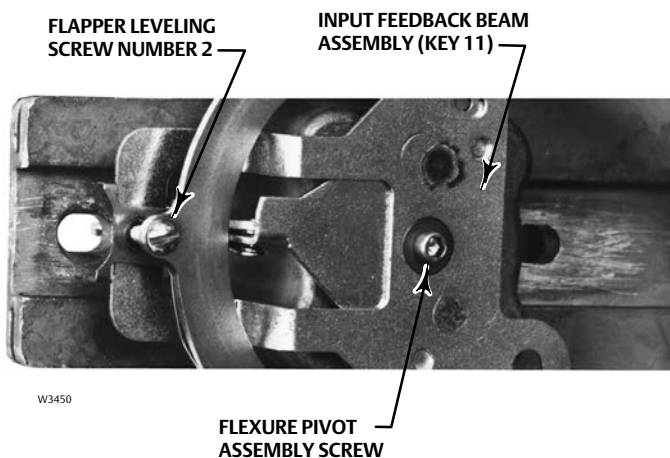

10. Disconnect link number 4 from the bellows bracket (key 31). Refer to figure 4-12 for location of the link.
11. Remove the screw (key 12) with washer (key 13) from the flexure pivot assembly (key 9). See figure 4-8 for screw location.
12. Remove the input feedback assembly as shown in figure 4-9.
13. Remove the four screws (key 10), shown in figure 4-9 that hold the flexure pivot assembly to the frame.
14. Remove the flexure pivot assembly (key 9).
15. Install the replacement flexure pivot assembly with the four screws (key 10). Do not tighten the screws.
16. Move the flexure pivot assembly toward the relay as far as possible, and tighten the four screws (key 10).
17. Place the input feedback beam assembly (key 11) onto the flexure pivot assembly (key 9) with link 4 through the square hole in the frame.
18. Install the screw (key 12) with the washer (key 13) through the input feedback beam assembly (key 11) into the flexure pivot assembly (key 9). Do not tighten the screw.

Figure 4-9. Exploded View of Flexure Pivot Assembly

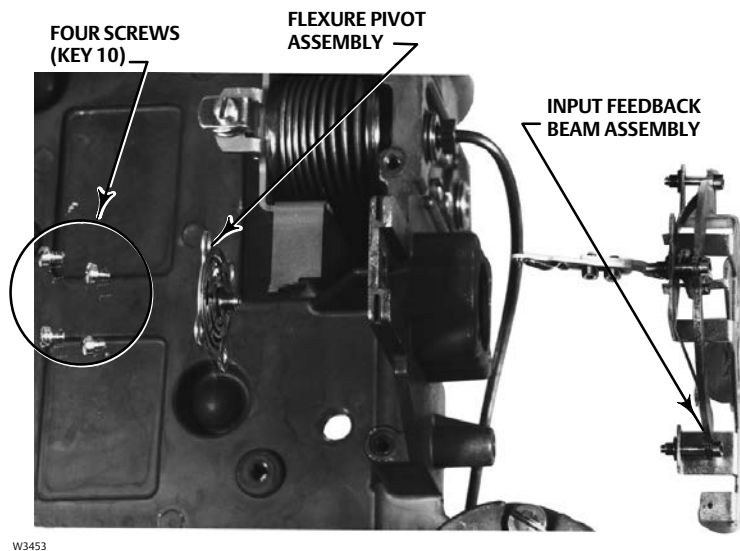

19. Align flapper leveling screw number 2 (see figure 3-1 for screw location) with the centerline of the oblong hole in the frame as shown in figure 4-8. Tighten the screw (key 12). Make sure link 4 does not touch the frame.
20. Disconnect link number 1 from the pivot assembly, and manually position the process pointer to 100 percent of the scale. Refer to figure 4-12 for location of link.
21. Adjust the length of link number 2 by turning the adjustment screw clockwise to increase the length or counterclockwise to decrease the length, so that the pin on the end of the link is approximately one-half of its diameter short of aligning with the hole in the input feedback beam assembly, as shown in figure 4-10.
22. Connect link number 2 to the input feedback beam assembly.
23. Connect link number 1 to the pivot assembly.
24. Adjust the proportional band between DIRECT and REVERSE. Do this by aligning the tab on the proportional band knob with the hole in the set point beam assembly as shown in figure 4-6.
25. Position the proportional band knob nozzle pivot and set point beam assembly on the frame, and install the relay nozzle tubing fitting loosely into frame manifold while positioning the nozzle in the center of the flapper as shown in figure 4-7.
26. Install the screw (key 19) through the frame (key 3) into the set point pivot assembly (key 23). Do not tighten.
27. Slide the set point pivot assembly (key 17) toward the set point beam until the cone lightly contacts the set point beam, and tighten the screws. The proportional band should fall freely when the controller is in the upright position. If it does not, reposition the set point pivot assembly (key 17).
28. Tighten the relay nozzle tubing nut (key 18). Apply supply pressure and check for leaks. Disconnect the supply pressure.
29. Install the washer (key 20) on the screw (key 19).
30. Install the screw (key 19) through the frame (key 3) and into the relay nozzle tubing assembly (key 18). Tighten the screw. Ensure the nozzle remains centered on the flapper with the set point beam assembly slid snugly towards the relay nozzle tubing assembly.

Figure 4-10. Link 2 Number Adjustment

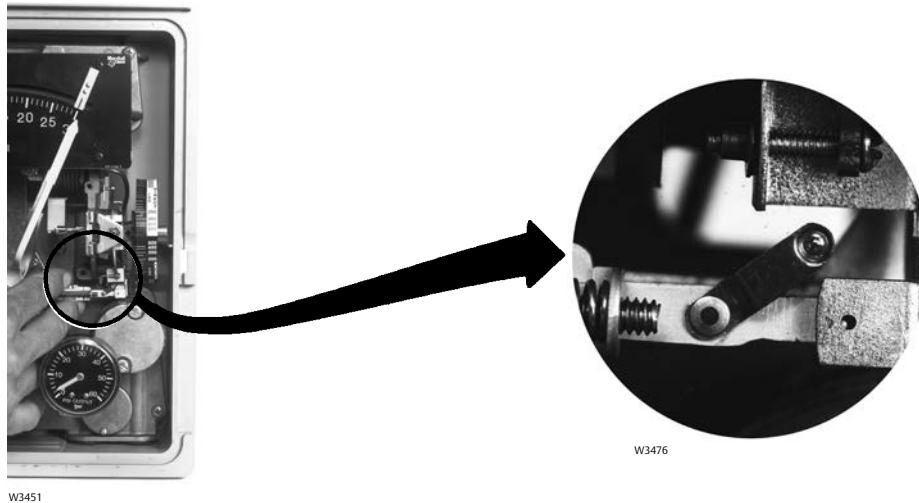

31. Install the pivot of the set point pivot assembly (key 17) in the hole in the set point beam.
32. Install washer (key 20) on screw (key 19).
33. Install the set point beam bias spring (key 28) into the frame (key 3) bore and onto the spring seat on the set point beam assembly (key 23).
34. Attach link number 3 to the set point beam assembly.
35. Apply proper supply pressure to the controller, and check for leaks.
36. Adjust the proportional band to 5 percent direct action, and adjust the set point to the maximum value on the process scale. Controller output should be 0 psig. Remove supply pressure from the controller.
37. With zero pressure in both feedback bellows, loosen the two adjusting screws on link 4, and connect the link to the bellows bracket assembly, allowing the link to find its free length.
38. Tighten the two adjusting screws.
39. If the position of the set point beam shoe (key 29) was changed during this procedure, perform steps 32 through 52 in the Replacing Proportional Band Knob, Nozzle Pivot, and Set Point Beam Assembly procedure. Otherwise, perform step 40.
40. Install the controller assembly in the case. Slide the controller frame down to assure an O-ring seal at the pressure connections. Hold the frame in place.
41. Install and tighten the nine screws that hold the controller assembly in the case.
42. Refer to the Flapper Alignment procedures.
43. Replace the proportional band cover (key 36), and replace the two screws (key 6).

Positive Feedback Bellows

Note

The following procedure requires that the controller be removed from the case. Perform steps 1 through 3 of the replacing case and cover procedure. Both bellows need not be removed if only one requires replacement.

1. Remove the two screws (key 6), and lift off the proportional band indicator cover (key 36).
2. Disconnect link 4 (key 65) from the bellows bracket (key 31).
3. Remove the screw (key 34), spring (key 33) and bellows adjustment bracket (key 32) from the bellows bracket (key 31).
4. Refer to figure 4-11 for locations. Remove two screws (key 35) from the bellows assembly.

Figure 4-11. Cutaway View of Bellows Assembly

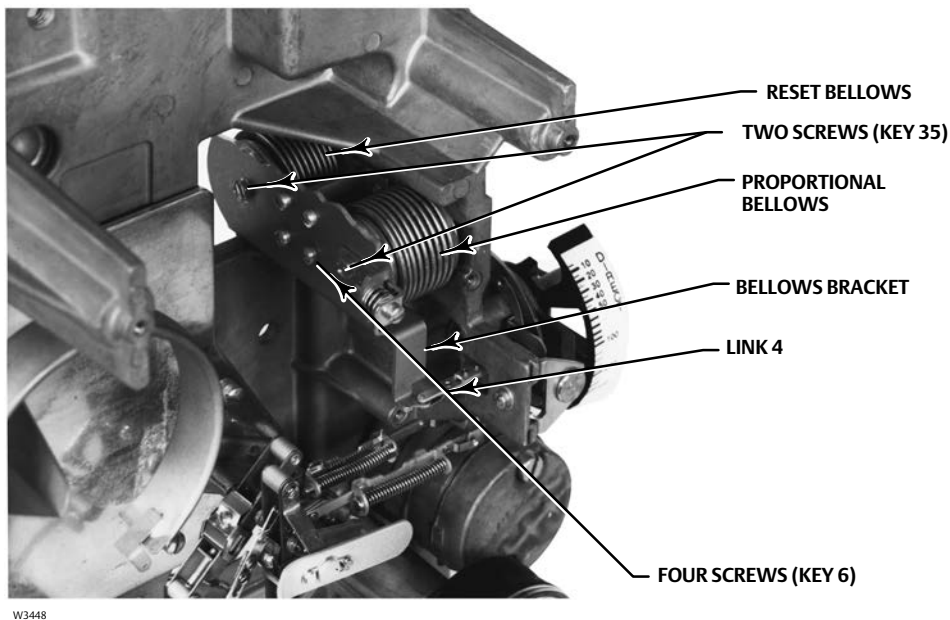

W3448

5. Remove the four screws (key 6) from the bellows beam (key 49), and remove the bellows bracket.
6. Remove the positive feedback tubing assembly (key 45) from the positive feedback bellows.

NOTICE

When removing and replacing positive feedback bellows, keep in mind that the bellows has left-hand threads. Overtightening could damage the threads.

7. Unscrew the bellows.
8. Before installing the replacement bellows, coat the threads with a suitable lubricant. Screw in the replacement bellows until it is finger tight against the frame (key 3).
9. Install the four screws (key 6) through the bellows bracket (key 31) into the bellows beam (key 49).
10. Install the two screws (key 35) through the bellows bracket (key 31) into the bellows. Install the bellows adjustment bracket (key 32), spring (key 33) and tighten the screw (key 34) until the spring is compressed completely. Tighten the two screws (key 35). Ensure the bellows bracket (key 31) is installed correctly so it does not rub against the frame.
11. Replace the positive feedback tubing assembly on the bellows base.

12. Apply the correct supply pressure, and check for leaks. Remove the supply pressure.
If the length of link 4 (key 65) was not changed, proceed with step 14.
13. If the length of link 4 (key 65) was changed during this procedure, refer to the replacement procedures for the flapper flexure pivot assembly. Perform steps 36 through 38 of the procedure.
14. Replace link 4 on the bellows bracket. Make sure the link does not touch the frame. If it does, repeat steps 8 through 12 to straighten the bellows bracket (key 31).
15. Refer to the Flapper Alignment procedures.
16. Remove the supply pressure, the output measurement device, and the regulated differential process pressure source.
17. Rotate the proportional band knob to the desired controller action. Replace the proportional band indication cover (key 36), and tighten the two screws (key 6).
18. Install the controller assembly in the case. Slide the controller frame down to assure an O-ring seal at the pressure connections. Hold the frame in place.
19. Install and tighten the nine screws that hold the controller assembly in the case.

Links

This section describes the separate replacement of five links in the controller. To clarify the location of each link (see figure 4-12), the links are numbered as follows: link number 1 connects short pivot assembly and the process pointer; link number 2 connects the process pointer and the input feedback beam assembly (key 11); link number 3 connects the set point adjustment and the set point beam assembly (key 23); link number 4 (key 65) connects the input feedback assembly and the bellows bracket (key 31). Link number 5 (key 88, figure 5-2) connects the short pivot assembly and the long pivot assembly. Figure 4-12 shows the location of each link.

Link Number 1

1. Remove the two screws (key 6) and lift off the proportional band indicator cover (key 36).
2. Note where the link is connected. Disconnect the link from the pivot arm (see figure 4-12) and from the process pointer assembly. Remove the link.
3. Attach the replacement link to the process pointer assembly and pivot arm in the position noted in step 2.
4. Adjust the set point manually or with remote set point pressure to 100 percent of the scale range, and set the proportional band between DIRECT and REVERSE.
5. The process pointer should be lined up with the pointer subassembly (as shown in figure 4-13). If not, loosen the zero adjustment locking screw. Then adjust the fine zero adjustment to align the process pointer and pointer subassembly.
6. With a regulated air supply, adjust process differential pressure to 50 percent of process scale range. The process pointer should be at the 50 ± 1.0 percent position on the scale. If not, loosen the screw (coarse zero adjustment shown in figure 4-12) in the link, and move the pointer to 50 percent of process scale, and tighten the screw.
7. Refer to the Maintenance Calibration and Flapper Alignment procedures.
8. Install the proportional band indicator cover (key 36) and tighten the two screws (key 6).

Figure 4-12. Link Location

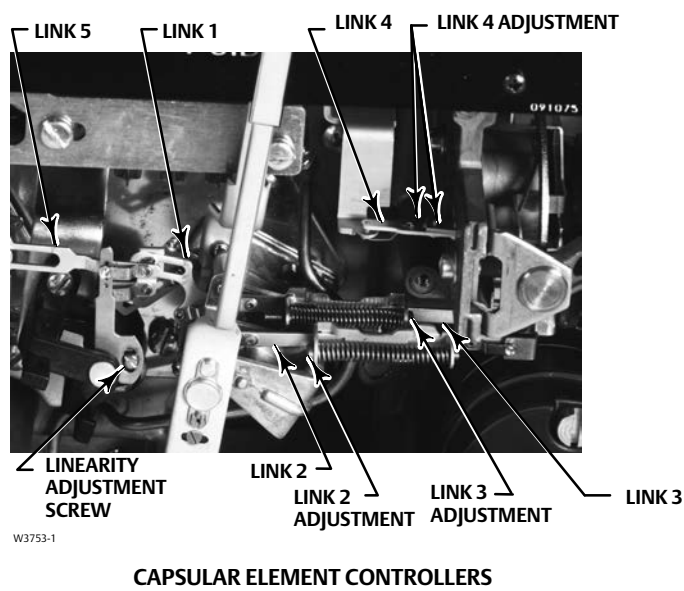
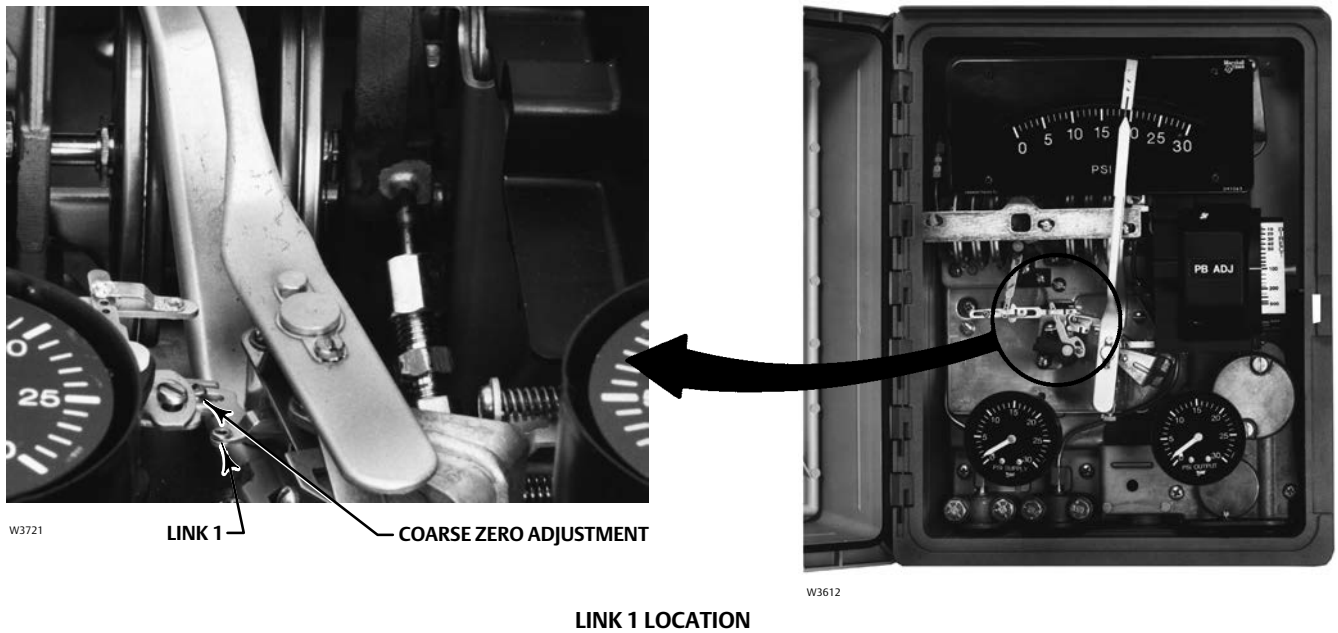
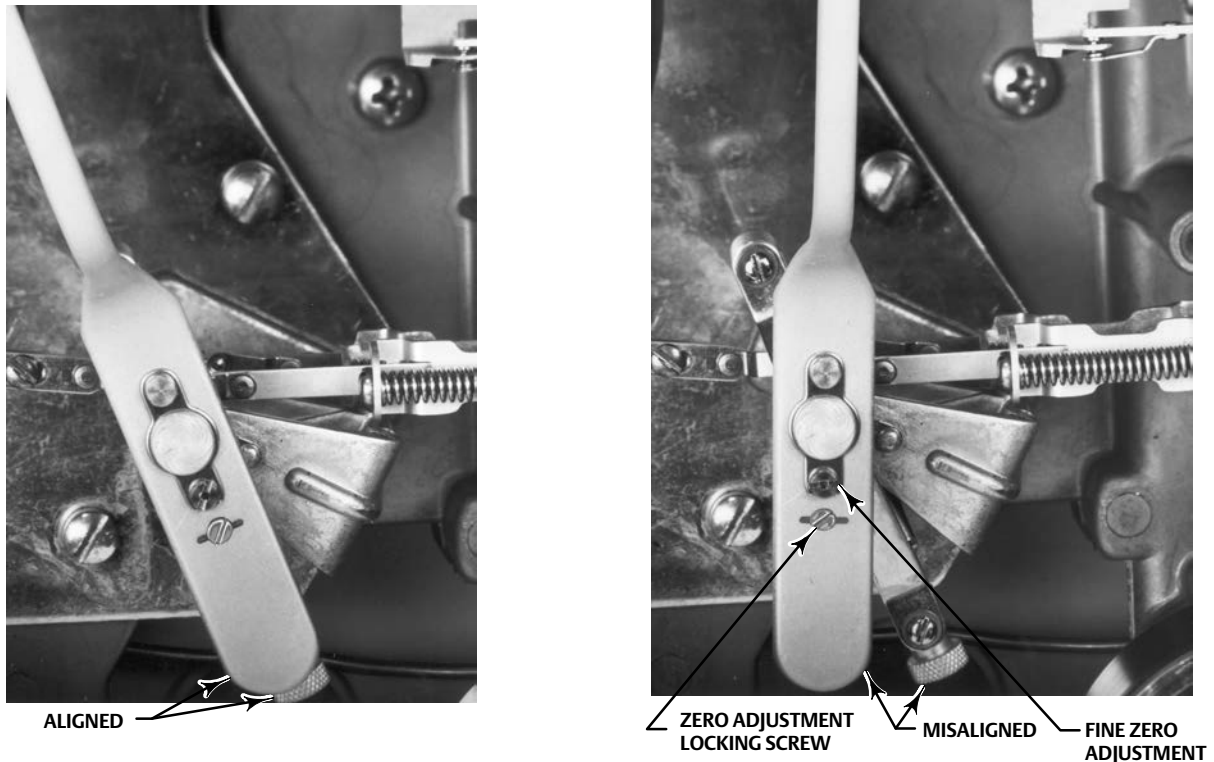

Figure 4-13. Process Pointer Alignment



W3443-1

W3475-1

Link Number 2

Note

Link number 2 is made of aluminum for temperature compensation purposes. Do not replace it with a link of other material.

1. Remove the two screws (key 6), and lift off the proportional band indicator cover (key 36).
2. Note where the link is connected. Disconnect the link from process pointer assembly and from the input feedback beam assembly (key 11). Remove the link.
3. Install the replacement link with the screw head nearest the process pointer as shown in figure 4-12. Connect the link to the process pointer assembly only, and in the position in step 2.
4. Adjust the set point manually or with the remote set point pressure to 100 percent of the process scale range. Set the proportional band between DIRECT and REVERSE.
5. Disconnect link number 1 from the pivot arm, manually position the process pointer to 100 percent on the scale.
6. Adjust the length of link number 2 (by turning the adjusting screw clockwise to increase length, counterclockwise to decrease length) so that the pin on the end of the link is approximately one-half of its diameter short of aligning with the hole in the input feedback beam assembly as shown in figure 4-10.

The adjustment provides the proper tension on the link.

7. Connect the link to the input feedback beam assembly.

8. Connect link number 1 to the pivot arm.
9. Refer to the Maintenance Calibration and Flapper Alignment procedures.
10. Replace the proportional band indicator cover (key 36), and tighten two screws (key 6).

Link Number 3

1. Remove the two screws (key 6), and lift off the proportional band indicator cover (key 36).
2. Note where the link is connected. Disconnect link number 3 from set point adjustment assembly and the set point beam assembly (key 23).
3. Install the replacement link with the screw head toward set point beam assembly as shown in figure 4-14, and in the position noted in step 2.
4. Check that set point beam bias spring (key 28) is correctly located in frame bore and spring seat on the set point beam assembly as shown in figure 4-5.
5. Adjust the proportional band between DIRECT and REVERSE.
6. Manually move the set point adjustment to 50 percent of scale. Adjust the screw on the link so that the edge of the proportional band knob is parallel to the set point adjustment as shown in figure 3-1.
7. Refer to the Maintenance Calibration and the Flapper Alignment procedure.
8. Replace the proportional band indicator cover (key 36), and tighten the two screws (key 6).

Link Number 4

1. Remove the two screws (key 6), and lift off the proportional band indicator cover (key 36).
2. Note where the link is connected. Disconnect the link from the bellows bracket assembly (key 31) and the input feedback assembly (key 11).
3. Connect the replacement link to the input feedback assembly so that the two adjusting screws on the link are nearest to the feedback bellows bracket. The screw heads should face the bottom of the controller as shown in figure 4-15, and be positioned as noted in step 2.

Figure 4-14. Link Number 3 Adjustment

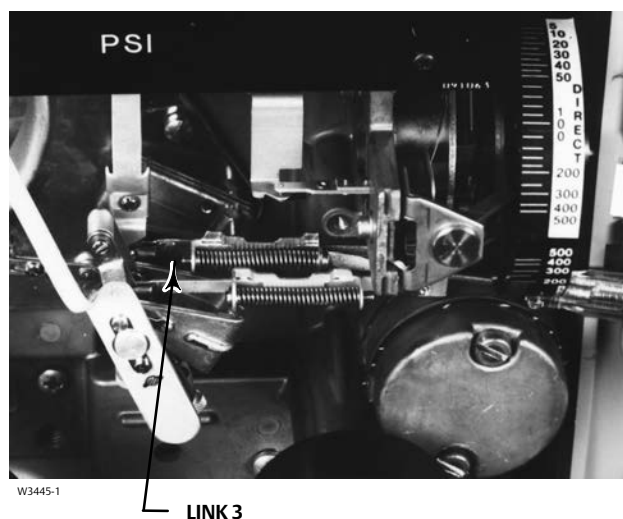
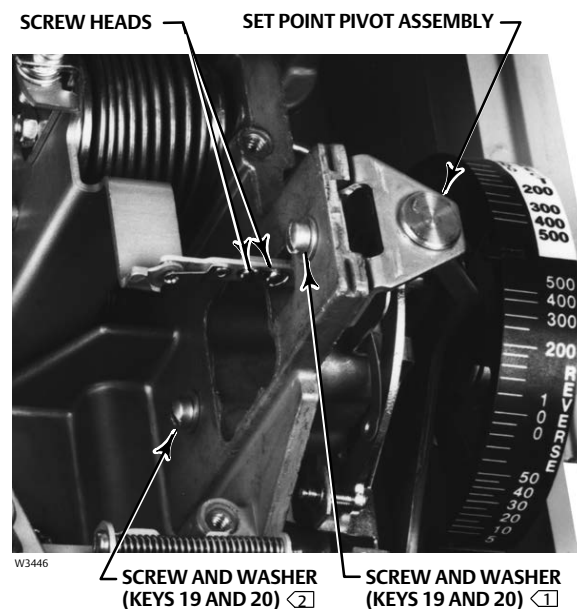

Figure 4-15. Position of Link Number 4 Adjusting Screws



- NOTES:
- ① SCREW INSERTED INTO THE SET POINT PIVOT ASSEMBLY.
 - ② SCREW INSERTED INTO THE RELAY NOZZLE TUBING ASSEMBLY.

4. Adjust the process differential pressure to 0 psid. Adjust the proportional band to 5 percent direct acting, and move the set point manually or with the remote set point pressure to 100 percent of process scale range. Controller output should be 0 psig.
5. With zero pressure in the feedback bellows, loosen the two adjustment screws on the link. Connect the free end of the link to the bellows bracket assembly, and allow the link to find its free length.
6. Tighten the two adjusting screws on the link.
7. Refer to the Maintenance Calibration and the Flapper Alignment procedure.
8. Replace the proportional band indicator (key 36), and tighten two screws (key 6).

Link Number 5

1. Refer to figure 5-2 for key number locations.
2. Note where the link is connected. Disconnect both ends of link 5 (key 88) from the lever arms of the two pivot assemblies.
3. Loosen the adjustment screw on the replacement link, and adjust the length to match the original link. Tighten the adjustment screw.
4. Attach the replacement link to the two lever arms in the same location as noted in step 2.
5. Refer to the Maintenance Calibration procedure.

Long Pivot Assembly

1. Remove the process pressure from the controller.
2. Remove the tie bar (key 97).
3. Note where the link is connected. Disconnect link 5 (key 88) from the lever arm on the pivot assembly (key 78).

NOTICE

Avoid bending or kinking the drive flexure. Bending or kinking the drive flexure can result in product damage, as well as impaired performance.

4. Disconnect the drive flexure (key 79) from the adjustment arm of the pivot assembly. Take care not to bend or kink the drive flexure.
5. Remove the two screws (key 102) attaching the pivot assembly to the mounting plate (key 77).
6. Loosen the screw on the adjustment arm of the replacement pivot assembly, and adjust the arm to the same length as the arm on the pivot assembly being replaced.
7. Attach the new pivot assembly to the mounting plate with the two mounting screws.
8. Loosely connect the drive flexure to the arm on the new pivot assembly.
9. Apply 75 percent of the input differential pressure range to the capsule. The flexure should be straight and horizontal. Before tightening the screws, set the pivot in the middle of the bushing end play. Tighten the flexure to hold the pivot in that position. Adjust the length of the adjustable pivot arm as needed until the flexure is straight. Take care not to kink or twist the flexure when tightening the screws.
10. Connect the left-hand end of link 5 (key 88) to the pivot lever arm in the position noted in step 3.
11. Replace the tie bar (key 97).
12. Refer to the Maintenance Calibration procedure.

Short Pivot Assembly

1. Remove the process pressure from the controller.

2. Disconnect links 1 and 5 (keys 88 and 90) from the pivot assembly (key 89). Note which holes they connect to. Remove the two screws (key 102) attaching the pivot assembly to the mounting plate (key 77), and remove the pivot assembly.
3. Set the linearity adjustment screw to approximately the same location as the old assembly.
4. Insert the replacement pivot assembly on the mounting plate, and attach it with the two mounting screws.
5. Attach links 1 and 5 (keys 88 and 90) in the same position as noted in step 2.
6. Refer to the Maintenance Calibration procedure.

Process Drive Flexure

1. Set the process differential pressure to 75 percent of input span.
2. Remove tie bar (key 97) by removing three screws (key 103) from the capsular assembly.
3. Remove the screws and washers (keys 12 and 13) to disconnect the drive flexure (key 79) from the drive bracket assembly (key 84) and from the adjustment arm of the pivot assembly (key 78). Remove the drive flexure.
4. Connect the replacement drive flexure in place, making sure it is straight and horizontal.
5. Before tightening the screws (key 12) set the pivot in the center of the bushing end play.

NOTICE

Avoid bending or kinking the drive flexure. Bending or kinking the drive flexure can result in product damage, as well as impaired performance.

6. Tighten the drive flexure to hold the pivot in position. Take care not to kink or twist the flexure when tightening the screws.
7. Refer to the Maintenance Calibration procedure.

Process Tubing

1. Remove the process pressure from the controller.
2. Disconnect the pressure tubing (keys 91 or 92) at the pedestal assembly (key 81) and at the bottom of the controller case.
3. Remove the tubing (keys 91 or 92) from the pressure elements.
4. Install the replacement tubing, and tighten all connections. Check for leaks.
5. Refer to the Maintenance Calibration procedure.

Capsular Element Assembly

Refer to figure 5-2 for key number location.

1. Remove the process pressure from the controller.
2. Disconnect link 1 (key 90) from the pointer. Note the hole location in the pivot and pointer assembly.
3. Disconnect the process pressure connection (key 93) from the pedestal assembly (key 81).
4. Remove the four mounting screws (key 127) that attach the capsular element to the process/set point indicating assembly.

NOTICE

In the following step, do not lift out the capsular element by holding the capsular element or linkages. These parts are easily damaged.

5. Lift out the capsular element assembly by holding the plate (key 77), travel stop (key 83), or pedestal (key 81).
6. Align the replacement capsular element assembly over the mounting screw holes. Install and tighten the mounting screws.
7. Reconnect link 1 (key 90) to the pointer subassembly in the same hole noted in step 3.
8. Reconnect the process pressure connections.
9. Apply process differential pressure to the controller, and check for leaks.
10. Refer to the Maintenance Calibration procedure.

Maintenance Calibration

Note

Perform full maintenance calibration (includes all procedures) upon completion of maintenance procedures. If only zero and span or linearity adjustments are required, use only those sections. Key numbers are referenced in figures 5-1 and 5-2. Adjustments are shown in figure 3-1. After Maintenance Calibration, perform the Flapper Alignment procedures if directed to do so. Otherwise, go to the appropriate prestartup instructions in the controller operation procedures.

⚠ WARNING

Refer to the Maintenance WARNING on page 21.

Precalibration Procedures

1. Set the proportional band adjustment to 5 percent direct acting. Adjust the set point to 100 percent of the process scale range.
2. Remove the tie bar (key 97).

Aligning the Drive Bracket Assembly

1. Loosen the set screw in the hex nut (key 86) of the drive bracket assembly (key 84)
2. Loosen the screw (key 98) that holds the guide flexure to the tab on the mounting plate.
3. Adjust the input pressure to 75 percent of full differential pressure span.
4. Slide the drive bracket assembly (key 84) along the diaphragm capsule extension (key 82) until the guide flexure is aligned with the center of pivot A (key 78).
5. Tighten the set screw in the hex nut to fasten the drive bracket assembly in that position.

Setting the Travel Stops

1. Loosen the set screw in the travel stop nut (key 86).

NOTICE

Make sure the loose travel stop nut does not bind up on the diaphragm capsule extension when pressurizing the capsules. Damage to the capsules may result.

2. Full span stop—Adjust process differential pressure to 5 percent greater than full span pressure.

Loosen the screws (key 139) mounting the travel stop (key 83) to the mounting plate. Slide the travel stop until it is just touching the end of the capsule stack. Tighten the travel stop mounting screws to lock it into that position.

3. Zero stop—Adjust pressure input to 0 percent of the full span.

Slide the travel stop nut (key 86), along the diaphragm capsule extension (key 82) until it is approximately 0.4 mm (1/64-inch) away from the travel stop. Tighten the set screw to lock the travel stop nut in that position.

Aligning the Linkage

1. Adjust the process differential pressure to 75 percent of the input span. The drive flexure (key 79) should be straight and horizontal. If it is not, proceed as follows:
 - a. Loosen the screw on the adjustment arm on the long pivot assembly (key 78) and the two screws mounting the drive flexure.
 - b. Adjust the length of the adjustment arm so that the drive flexure is parallel to the centerline of the capsules.
 - c. Tighten the screw to set the length of the adjustment arm in that position. Before retightening the screws, set the pivot in the middle of the bushing end play.
 - d. Tighten the drive flexure to hold the pivot in that position.
2. Tighten the guide flexure to the mounting plate.
3. Set the linearity adjustment screw on the short pivot assembly in the middle of its slot.
4. Make certain that the process pointer and pointer subassembly are aligned (see figure 4-13). Change the length of link 1 (key 90) to the middle of its adjustment.
5. The short (bottom) arm on the short pivot assembly (key 89) should be parallel with the process pointer and the pointer subassembly.
6. Turn the span adjustment screw on the bottom of the process pointer counterclockwise as far as it will go so the span adjustment bracket will be in its highest position.
7. Adjust the process differential pressure to 50 percent of full input span. Adjust the length of link 5 (key 88) so that the pivot level arms are as close to parallel as possible.
8. To complete maintenance calibration, the zero and span adjustments must be set. Refer to the following section for that procedure. If linearity adjustments must also be made, refer to that portion of the procedures.
9. Replace the tie bar (key 97) after the controller is calibrated.
10. Refer to the Flapper Alignment procedures.

Process Zero-and-Span Adjustment

1. Remove the two machine screws (key 6) and lift off the proportional band indicator cover (key 36).
2. Set the proportional band between DIRECT and REVERSE.
3. Apply 0 percent of the process differential pressure input span.
4. Loosen the screw on link 5 (key 88) and adjust the length so that the process pointer points to scale zero. Tighten the screw.
5. Make fine zero adjustments by loosening the zero adjustment locking screw on the process pointer and turning the zero adjustment screw. Tighten the locking screw.
6. Apply 100 percent of the process pressure input span.
7. To increase the span, proceed as follows:

- a. Turn the span adjustment screw clockwise. (Adjust the span to correct one-half the error).
 - b. To increase the span further than the adjustment will allow, move both ends of link 5 (key 88) down one set of holes. Refer to figure 4-12 for link location.
 - c. Make fine adjustments with the span adjustment screw.
8. To decrease the span, proceed as follows:
- a. Turn the span adjustment screw counterclockwise. (adjust span to correct one-half the error).
 - b. To decrease the span further than the adjustment will allow, move both ends of link 5 (key 88) up one set of holes.
 - c. Make fine adjustments with the span adjustment screw.
9. Repeat the adjustments until zero and span indications are within ± 1 percent of input span.
10. Check the pointer position at 50 percent of full process pressure input span. If the error is greater than ± 1 percent of input span, perform the procedures in the Linearity Adjustment procedure. Remove process pressure from the controller.
11. Install the proportional band indicator cover (key 36), and tighten the two screws (key 6).

Linearity Adjustment

Adjust the linearity by turning the linearity adjustment screw in the curved slot on the lever arm of the short pivot assembly (key 89). Adjusting the linearity affects the zero and span.

1. Adjust the process differential pressure to 50 percent of input span. The process pointer should indicate the 50 percent mark on the scale.
2. If the pointer indicates high, turn the linearity screw counterclockwise in the slot. If the pointer indicates low turn the linearity screw clockwise in the slot.
3. Check the zero and span as described in the Zero-and-Span Adjustment procedures and make any necessary adjustments.
4. Repeat steps 1 through 3 until zero, span, and linearity indications are within ± 1 percent of input span.

Flapper Alignment

WARNING

Refer to the Maintenance **WARNING** on page 21.

Leveling screws numbers and adjustments are shown in figure 3-1. Provide a means of applying process differential pressure and supply pressure to the controller and a means of measuring output pressure. After flapper alignment, go to the appropriate prestart-up instructions in the controller operation procedures.

1. For controllers with manual set point, move the set point adjustment to 50 percent of the scale range. For controllers with remote set point (option M), adjust the remote set point pressure until the set point indicator is at 50 percent of the scale range.
2. Remove the two screws (key 6) and lift off the proportional band indicator cover (key 36).
3. Adjust the proportional band adjustment to 5 percent direct acting.

⚠ WARNING

In step 4, do not exceed the operating limits for the controller (refer to table 1-3). Personal injury or equipment damage may result from overpressure.

4. Slowly increase the process differential pressure from zero until the output pressure snaps to supply pressure. The output pressure should snap to supply pressure within ± 2 percent of set point.
5. If the output snaps to supply pressure below 2 percent of set point, adjust flapper leveling screw number 3 clockwise. If the output snaps above 2 percent of set point, adjust flapper leveling screw number 3 counterclockwise.
6. Repeat steps 4 and 5 until the output pressure snaps within ± 2 percent of set point.
7. Adjust the proportional band adjustment between DIRECT and REVERSE.
8. If the output pressure snaps to supply pressure, depress the flapper with a screwdriver so the output pressure snaps to zero pressure. Slowly release the flapper. If the output snaps to supply pressure, adjust flapper leveling screw number 2 clockwise until the output does not snap to supply pressure. Then, adjust screw number 2 counterclockwise $1/8$ of a turn at a time until the output snaps to supply pressure.
9. Repeat step 8 to recheck the adjustment of flapper leveling screw number 2.
10. Adjust the proportional band adjustment to 5 percent reverse acting.
11. Carefully adjust the process differential pressure to 100 percent of the process scale range. Then, slowly decrease the process pressure until the output pressure snaps to supply pressure. The output pressure should snap to supply pressure within ± 2 percent of set point.
12. If the output pressure snaps to supply pressure below 2 percent of set point, adjust flapper leveling screw number 1 counterclockwise. If the output snaps to supply above 2 percent of set point, adjust flapper leveling screw number 1 clockwise.
13. Repeat steps 11 and 12 until the output pressure snaps within ± 2 percent of set point.
14. Repeat steps 3 through 13 to recheck adjustments. Continue to adjust flapper leveling screws 1, 2, and 3 as necessary until no flapper adjustments are required.
15. Set the proportional band adjustment to 400 percent in the desired controller action. Replace the proportional band indicator cover (key 36), and tighten the two screws (key 6).

Remote Set Point (Option M)

Replacing Parts

⚠ WARNING

Refer to the Maintenance WARNING on page 21.

Note

After part replacement, perform the Maintenance Calibration procedures.

Figure 3-2 shows the location of the parts. Key numbers refer to figure 5-3.

Pivot Assembly A (Key 114)

NOTICE

Avoid bending or kinking the drive flexure during the following procedure. Bending or kinking the drive flexure can result in product damage, as well as impaired performance.

1. Decrease the remote set point pressure to 0 psig.
2. Remove the tie bar (key 106).
3. Note where link A (key 116) is connected. Disconnect the link from the lever arm on the pivot assembly.
4. Disconnect the drive flexure (key 79) from the adjustment arm of the pivot assembly. Be careful not to bend or kink the drive flexure.
5. Remove the screw (keys 122), the washer (key 123) and the nut (key 124) that attach the guide flexure to the top of the pivot assembly.
6. Remove the pivot screw and spring washer (keys 109 and 112) and the mounting screw (key 102) attaching the pivot assembly to the mounting plate. Lift out the pivot assembly.
7. Loosen the screw (key 118) on the adjustment arm of the replacement pivot assembly, and set the arm to the same length as the arm on the pivot assembly being replaced. Tighten the screw.
8. To replace the pivot assembly, first put the spring washer on the screw. Then, install the screw through the pivot assembly into the mounting plate.
9. Connect the guide flexure to the top of the new pivot assembly with the screw (key 122), the washer, and the nut as it was before.
10. Increase the remote set point pressure to 50 percent of input span.
11. Connect the drive flexure to the arm on the new pivot assembly, making sure it stays straight and horizontal. Before tightening down the drive flexure, set the pivot in the middle of the bushing end play. Tighten down the drive flexure to hold the pivot in that position. Do not kink or twist the flexure when tightening the screws. Adjust the length of the pivot arm if necessary until the flexure is straight.
12. Decrease the remote set point pressure to 0 psig.
13. Connect the end of link A (key 116) to the pivot lever arm in the same position noted in step 3.
14. Replace the tie bar (key 106).
15. Refer to the Maintenance Calibration procedure.

Pivot Assembly B (Key 115)

1. Refer to figure 5-3 for the key-numbered assembly.
2. Decrease the remote set point pressure to 0 psig.
3. Note where the links are connected. Disconnect the links (keys 116 and 126) from the arms of pivot assembly (key 115).
4. Remove the two screws (key 102) attaching the pivot assembly to the mounting plate (key 111). Remove the pivot assembly.
5. Loosen the linearity adjustment screw on the replacement pivot assembly and set it in the same position as the adjustment on the original pivot assembly. Tighten the screw.
6. Set the replacement pivot assembly on the mounting plate, and attach it with the two machine screws.
7. Attach the links (keys 116 and 126) to the arms of the new pivot assembly in step 3.

8. Refer to the Maintenance Calibration procedure.

Drive Flexure

1. Disconnect the flexure (key 79) from the drive bracket (key 121) and from the adjustment arm of pivot assembly A. Remove the screws and washer (key 12 and 13); remove the flexure.
2. Set remote set point pressure at 50 percent of input span.

NOTICE

Avoid bending or kinking the drive flexure. Bending or kinking the drive flexure can result in product damage, as well as impaired performance.

3. Connect the new flexure making sure it stays straight and horizontal. Before tightening the drive flexure, set pivot A in the middle of the bushing end play. Tighten down the drive flexure to hold the pivot in that position. Do not kink or twist the flexure when tightening the screws.
4. Decrease the remote set point pressure to 0 psig.
5. Perform the Maintenance Calibration procedure.

Tubing

1. Decrease the remote set point pressure to 0 psig.
2. Disconnect the pressure connection (key 93) into the pedestal assembly (key 105) and the connection to the case exterior at the top of the case.
3. Remove the tubing.
4. Install the replacement tubing, and reconnect the two pressure connections.
5. Apply full remote set point pressure, and check for leaks.

Remote Set Point Capsular Element Assembly

Note

Remove the supply pressure gauge before attempting to remove the capsular element assembly.

1. Decrease the remote set point pressure to 0 psig.
2. Remove the pressure connection (key 93) at the pedestal assembly (key 105).
3. Disconnect link B (key 126) from the pivot hole on set point indicator assembly.
4. Remove the three mounting screws that attach the capsular element assembly to the process/set point indicator assembly. See figure 3-2 for location of screws.

NOTICE

In the following step, do not lift out the capsular element assembly by holding the capsule or the linkages. These parts are easily damaged.

5. Lift out the capsular element assembly by holding the plate (key 111), travel stop (key 83), or pedestal assembly (key 105).
6. Align the replacement assembly with the mounting screw holes. Replace the mounting screws.
7. Reconnect the process pressure connection union (key 93). Apply remote set point pressure, and check for leaks.
8. Connect the link (key 126) to the pivot hole on the set point indicator assembly.
9. Replace the supply pressure gauge.
10. Refer to the Maintenance Calibration procedure.

Link A

1. Note the holes where link A (key 116) is connected (see figure 5-3). Disconnect both ends of the link from the lever arms on the two pivots.
2. Loosen the screw in the replacement link, and adjust the length to match the link being replaced. Tighten the screw. Refer to figure 5-3 for correct orientation of the link.
3. Attach the replacement link to the two lever arms in the same position as noted in step 1.
4. Check the zero setting, and adjust if necessary as described in the Zero-and-Span Adjustment procedure.

Link B

1. Note the holes where link B (key 126) is connected (see figure 5-3). Disconnect both ends of the link from the pivot arm and from the set point indicator assembly.
2. Loosen the screw in the replacement link, and adjust the length to match the link being replaced. Tighten the screw.
3. Attach both ends of the replacement link. Refer to figure 5-3 for correct orientation of the link, and position the link as noted in step 1.
4. Refer to the Maintenance Calibration procedure.

Maintenance Calibration

Note

Perform all Maintenance Calibration procedures upon completion of maintenance. If only zero, span, and linearity adjustments are required, use only those sections. After Maintenance Calibration, go to the appropriate prestartup instructions in the controller operation procedures.

WARNING

Refer to the Maintenance WARNING on page 21.

Refer to figure 3-2 for parts location. Key numbers refer to figure 5-3.

Precalibration Procedure

1. Set the proportional band adjustment between DIRECT and REVERSE.
2. Remove the tie bar (key 106).

3. Apply 50 percent of full span remote set point pressure.
4. The drive flexure (key 79) should be straight. If not, proceed as follows:
 - a. Loosen the screw on the adjustment arm on pivot assembly A (key 114) and the screws holding the drive flexure.
 - b. Set the length of the adjustment arm so that the drive flexure is parallel to the centerline of the capsules.
 - c. Tighten the screw on the adjustment arm.
 - d. Set pivot A in the middle of the bushing end play.
 - e. Tighten the screws that hold the drive flexure in place.
5. The guide flexure should also be straight. If not, loosen the screw (key 122) on the end of the flexure that is attached to the top of pivot A (key 114), and allow the flexure to straighten itself. Tighten screw on the flexure.

Setting the Travel Stops

1. Loosen the set screw in the travel stop nut (key 86).

NOTICE

Make sure the loose travel stop nut does not bind up on the diaphragm capsule extension when pressurizing the capsules. Damage to the capsules may result.

2. Full span stop—Adjust remote set pressure input to 5 percent greater than full span pressure.

Loosen the two screws mounting the travel stop (key 83) to the mounting plate. Slide the travel stop until it is just touching the end of the capsule stack. Tighten the travel stop mounting screws to lock it into that position.

3. Zero Stop—Adjust remote set point pressure input to 0 psig.

Slide the travel stop nut (key 86), along the diaphragm capsule extension (key 134) until it is approximately 0.4 mm (1/64 inch) away from the travel stop (key 83). Tighten the set screw to lock the travel stop nut in that position.

Aligning the Linkage

1. Adjust the remote set point pressure to the capsules to 50 percent of full span.
2. Set the linearity adjustment screw in the center of the slot on the lever arm of pivot clevis assembly B (key 115).
3. Set the length of link B (key 126) in the middle of its adjustment.
4. Set the length of link A (key 116) so that the lever arms of pivots A and B are parallel and that link A is perpendicular to them.
5. To complete maintenance calibration, the zero and span adjustments must be set. Refer to the following section for the procedures. If linearity adjustments must also be made, refer to that portion of this section.
6. Replace the tie bar (key 106).
7. Refer to the Flapper Alignment procedure.

Zero and Span Adjustment

1. Decrease remote set point pressure to 0 psig.
2. Loosen the screw on link A (key 116), and adjust the length so that the set point pointer points to scale zero. Tighten the screw.

3. Make fine zero adjustments by loosening the zero adjustment locking screw and turning the zero adjustment screw (key 108). Tighten the locking screw. Refer to figure 5-3 for location of the screws.
4. Apply 100 percent of the remote set pressure input span.
5. To increase the span, proceed as follows:
 - a. Turn the span adjustment screw clockwise. (Adjust span to correct one-half the error).
 - b. To increase the span further than the adjustment screw allows, move both ends of link A to the right. Refer to figure 5-3 for link location.
 - c. Make fine adjustments with the span adjustment screw.
6. To decrease the span, proceed as follows:
 - a. Turn the span adjustment screw counterclockwise. (Adjust span to correct one-half the error).
 - b. To decrease the span further than the adjustment screw allows, move both ends of link A to the right. Refer to figure 5-3 for link location.
 - c. Make fine adjustments with the span adjustment screw.
7. Repeat the adjustments until the zero and span indications are within ± 1 percent of input span.
8. Check the pointer position at 50 percent of full pressure input span. If the error is greater than ± 1 percent of input span, perform the Linearity Adjustment procedures.

Linearity Adjustment

Adjust the linearity by rotating the linearity adjustment screw in the curved slot on the lever arm of pivot B (key 115). Adjusting the linearity affects the zero and span adjustment.

1. Adjust the remote set point pressure to 50 percent of the input span. The set point indicator should indicate the 50 percent mark on the scale.
2. If the pointer indicates high, loosen the linearity screw, and rotate it counterclockwise in the slot. If the pointer indicates low, rotate the linearity screw clockwise in the slot.
3. Check the zero and span as described in the Zero and Span Adjustment procedures. Make any necessary adjustments.
4. Repeat steps 1 through 3 until zero, span, and linearity indications are within ± 1 percent of input span.

Auto/Manual (Option E)

WARNING

Refer to the Maintenance WARNING on page 21.

Note

Each of the following procedures requires that the controller be removed from the case. Perform steps 1 through 3 of the replacing case and cover procedure.

Replacing the Auto/Manual Station

Refer to figures 4-19, 5-4, and 5-5 for key number locations.

Note

This procedure also permits replacement of the switch manifold O-rings (key 312), the auto/manual tubing assembly (key 138), and the frame gaskets (keys 4 and 5).

Disassembly

1. Perform steps 1 through 3 of the replacing case and cover procedure.
2. Loosen the screw (key 316) that holds the auto/manual station (key 273) to the controller frame.
3. Loosen the two screws (keys 314 and 315) that hold the auto/manual station to the auto/manual tubing assembly (key 138).
4. Remove the auto/manual station from the controller frame.
5. Remove the switch manifold O-rings (key 312).
6. Carefully loosen the nut on the relay nozzle tubing assembly (key 18) where it connects to the auto/manual tubing assembly (key 138). Loosen three screws (keys 34 and 131) and remove the tubing assembly and frame gaskets (keys 4 and 5).
7. Inspect the gaskets (keys 4 and 5) and O-rings (key 312) for wear. Replace if necessary.

Assembly

1. Install the gaskets and tubing assembly to the frame. Start, but do not tighten, the three screws (keys 34 and 131) and the nut on the relay nozzle tubing assembly (key 18).
2. Install the three O-rings (key 312), and secure the auto/manual station to the controller frame with the screw (key 316) and to the tubing assembly (key 138) with the two screws (keys 314 and 315). Do not tighten any screws.

NOTICE

In the next step, take care to tighten the two screws (keys 314 and 315) evenly. Uneven tightening could damage the tubing assembly.

3. Position the auto/manual station as far down on the frame and toward the scale as possible. Carefully tighten the two screws (keys 314 and 315) so that the auto/manual station contacts the three pads on the tubing assembly.
4. Carefully tighten the remaining screws and nuts.
5. Apply air pressure to the controller, and check for leaks.
6. Install the controller assembly in the case. Slide the controller frame down to assure an O-ring seal at the pressure connections. Hold the frame in place.
7. Install and tighten the nine screws that hold the controller assembly in the case.
8. Refer to the Flapper Alignment procedure.

Replacing the Switch Body Assembly, Lever O-Ring, Switch Body O-Ring, and the Tubing Assembly

Refer to figure 5-5 for key number location.

Disassembly

1. Perform steps 1 through 3 of the replacing case and cover procedure.
2. Remove the auto/manual station from the controller frame as described in steps 1 through 4 of the Replacing the Auto/Manual Station procedure.
3. Loosen the two screws (key 288) and remove the lever cover plate (key 305).

⚠ WARNING

The lever spring (key 302) is under preload. To avoid personal injury or losing parts, carefully disassemble the auto/manual station.

4. Using a 1.5 mm (0.0625 inch) punch, push the groove pin (key 303) out toward the surface of the lever cover plate.

Note

When removing the groove pin, hold onto the switch lever (key 304) and slow pull the switch lever from the lever assembly shaft (key 297). Then, remove the lever spring (key 302) and lever spring seat (key 301).

5. Remove the switch lever (key 304), lever spring (key 302), and lever spring seat (key 301).
6. Remove the tubing assembly (key 309).

⚠ WARNING

The switch body springs (key 295) are under preload. To avoid personal injury or losing parts, carefully separate the switch body assembly from the loader assembly.

7. Loosen the two screws (key 290), and separate the switch body assembly (key 291) from the loader assembly (key 282).
8. Remove the O-rings (keys 292, 293, and 294), switch body springs (key 295), and balls (key 296).
9. Loosen two screws (key 308), and remove the closing plate (key 307) and the closing plate gasket (key 306).
10. Pull the clip (key 300) from its engagement with the lever assembly shaft (key 297).
11. Pull the lever assembly from the switch body assembly (key 291) and rocker (key 299).
12. Remove the O-ring (key 298).
13. Inspect the O-rings and gaskets for damage or wear; replace if necessary.

Assembly

1. Insert the lever assembly (key 297) into the switch body assembly (key 291) and hold the rocker (key 299) with the flats on the lever assembly shaft.
2. Insert the clip (key 300) in the groove of the lever assembly shaft to hold the lever assembly (key 297) in the switch body assembly (key 291).
3. Position the closing plate gasket (key 306) and the closing plate (key 307). Secure with two screws (key 308).

Note

After assembly in step 3, be sure the side of the closing plate marked OUT is visible.

4. Place the balls (key 296), switch body springs (key 295), and O-rings (keys 292, 293, and 294) in the switch body assembly (key 291).

Note

In the following step, the ends of the springs must be in the counterbored spring seats before compression.

5. Compress the switch body springs with the loader assembly (key 282), and bolt the switch (key 291) to the loader assembly with the two screws (key 290).
6. Reconnect the tubing assembly (key 309).
7. Locate the lever spring (key 302) and the spring seat (key 301) on the switch lever (key 304) and position these parts in the opening of the loader assembly (key 282).
8. Push the switch lever down, using the lever spring seat (key 301) and the lever assembly (key 297) to preload the spring. Make sure the notch of the switch lever engages the pin of the lever assembly.
9. Drive in the groove pin (key 303) to hold the switch lever.
10. Replace the lever cover plate (key 305) and attach with two screws (key 288).
11. Perform the Assembly portion of the Replacing the Auto/Manual Station procedure.

Replacing the Loader Range Spring, Diaphragm Assembly, Ball Seat, Tubing, and Ball

Refer to figure 5-5 for key number location.

Disassembly

1. Perform steps 1 through 3 of the replacing case and cover procedure.
2. Remove the auto/manual station from the controller as described in steps 1 through 4 of the Replacing the Auto/Manual Station procedure.
3. Remove the tubing assembly (key 309).

⚠ WARNING

To avoid personal injury caused by preload from the range spring (key 282), turn the loader knob (key 287) counterclockwise (opposite to the arrow) to relieve pressure on the spring.

4. Loosen the four screws (key 289), and separate the upper loader assembly (key 282) and the lower loader assembly (key 274).
5. Remove the loader range spring (key 283), range spring cup (key 284), and diaphragm assembly (key 281).
6. Remove the tube (key 278), ball seats (key 280) and ball (key 279).

Assembly

1. Turn the loader knob (key 287) counterclockwise to back the spring adjustment screw (key 285) all the way out to eliminate loading the range spring.
2. Position the range spring cup (key 284), range spring (key 283), and the diaphragm assembly (key 281) on the upper loader assembly (key 282).

3. Position the ball (key 279), the tube (key 278), and the ball seats (key 280) between the ears of the loader assemblies (keys 282 and 274); position the diaphragm assembly (key 281) between the main halves of the loader assemblies.

Note

The tube (key 278) must be well seated in the cups of the ball seats (key 280).

4. Bolt the loader assembly halves together using the four screws (key 289).

Note

Be sure that the supply and exhaust seats of the loader are correctly aligned. Misalignment will impair loader performance.

5. Attach the tubing assembly (key 309).
6. Perform the Assembly portion of the Replacing the Auto/Manual Station procedure.

Replacing the Loader Valve Plug and Valve Plug Spring

Refer to figure 5-5 for key number location.

1. Perform steps 1 through 3 of the replacing case and cover procedure.
2. Loosen the spring seat screw (key 275).
3. Remove the valve plug spring (key 276) and the valve plug (key 277).
4. Inspect the parts, and replace as necessary.
5. Install the valve plug spring and valve plug.
6. Tighten the spring seat screw.
7. Temporarily apply supply pressure and process pressure and check for leaks.
8. Install the controller assembly in the case. Slide the controller frame down to assure on O-ring seal at the pressure connections. Hold the frame in place.
9. Install and tighten the nine screws that hold the controller assembly in the case.

Section 5 Parts Ordering

Whenever corresponding with your [Emerson sales office](#) about this equipment, always mention the controller serial number.

⚠ WARNING

Use only genuine Fisher replacement parts. Components that are not supplied by Emerson, should not, under any circumstances, be used in any Fisher instrument. Use of components not supplied by Emerson may void your warranty, might adversely affect the performance of the instrument, and could cause personal injury or property damage.

Parts Kits

Description	Part Number
4190 Controller Auto/Manual Retrofit Kit (see figure 5-4) Contains keys 138, 273, 312, 313, 314, 315, 316 SST tubing	R4190X00512
4190 Controller Auto/Manual Repair Kit (see figure 5-5) Contains keys 277, 278, 279, 281, 292, 293, 294, 295, 298, 306, 312	R4190X0AM12
4190 Controller Case Handle Kit Contains lever and mounting hardware	R4190X00H12
4190 Controller Repair Kit Contains keys 4, 5, 7, 8, 24, 52	R4190X00C12
4190 Controller Pointer and Bracket Repair Kit Contains pointer and bracket ass'y, 3 machine screws, 3 washers	R4190X00P12
4190 Controller Relay Replacement Kit Contains Relay Assembly, key 50 0.2 to 1.0 bar (3 to 15 psig) 0.4 to 2.0 bar (6 to 30 psig)	RRELAYX83C2 RRELAYX83D2

Parts List

Note

Contact your Emerson sales office for Part Ordering information.

General Controller Parts and Bourdon Tubes (figure 5-1)

Key	Description
1	Case and cover ass'y w/o remote set w/remote set
2	Nameplate
3	Frame
4*	Frame gasket
5*	Gasket
6	Machine screw (9 req'd)
7*	O-Ring (specify quantity req'd)
8*	O-Ring (3 req'd)
9	Flexure pivot ass'y
10	Machine Screw (4 req'd)
11*	Input/Feedback Beam Assembly (Flapper Assembly)
12	Machine Screw
17	Set Point Pivot Assembly
18	Relay Nozzle Tubing Assembly
19	Machine Screw (2 req'd)
20	Plain Washer (2 req'd)

*Recommended spare parts

Key	Description	Key	Description
21	Nozzle Assembly	60	Reducing Adaptor (2 req'd)(use only when specified)
22	Washer (2 req'd)	61	Process scale
23	Set Point Beam Assembly	62	Remote set assembly (for 4194SM, and SME only) 0.2 to 1.0 bar (3 to 15 psig) 0.4 to 2.0 bar (6 to 30 psig)
25	Proportional Band Knob	64	Machine screw (4 req'd)
26	Retaining clip	65	Feedback Link Assembly
27	E-ring	71	Machine screw (4 req'd)
28	Set Point Beam Bias Spring	72	Blowout plug
29	Set Point Beam Shoe	80	Diaphragm Capsule Assembly for 4194SM and SME only (not shown) 0.2 to 1.0 bar (3 to 15 psig) 0.4 to 2.0 bar (6 to 30 psig)
30	Machine Screw (2 req'd)	101	Indicator Assembly
31	Bellows Bracket	113	Capsule Assembly 0 to 350 mbar (3 to 5 psid) 0 to 0.7 bar (0 to 10 psid) 0 to 1.4 bar (0 to 20 psid) 0 to 2 bar (0 to 30 psid)
32	Bellows Adjustment Bracket	120	Machine Screw ⁽¹⁾ (2 req'd) (for 4195SM and SME only)
33	Bellows Adjustment Spring	127	Machine Screw ⁽²⁾ (4 req'd)
34	Machine Screw (2 req'd)	131	Machine Screw (2 req'd)
35	Machine screw (2 req'd)	135	Frame Manifold (for 4194S and SME only)
36	Proportional Band Indicator Cover	136	Rate/Reset Manifold
37	Self-Tapping Screw (4 req'd)	138	Manual/Automatic Tubing Assembly (for 4194SE and SME only)
38	Self-Tapping Screw (9 req'd)	140	Machine Screw ⁽¹⁾ (for 4194SM and SME only)
39	Supply Gauge Tubing Assembly	162	Machine Screw
41	Plug	310	Lithium grease (not furnished with controller)
45	Positive Feedback Tubing Assembly	311	Anti-seize sealant (not furnished with controller)
46*	Output Gauge	317	Silicone-based lubricant (not furnished with controller)
47*	Supply Gauge	318	Lubricant, silicone (not furnished with controller)
48*	Bellows ass'y (2 req'd)	338	Machine Screw (2 req'd)
49	Bellows Beam 0.2 to 1.0 bar (3 to 15 psig) 0.4 to 2.0 bar (6 to 30 psig)	362	Washer
50	Relay Assembly (included in the Replay Replacement kit)		
51	Relief Valve Cover Plate		
52*	O-ring		
53	Machine screw (2 req'd)		
56	Process/Set Point Indicator Assembly		
57	Pressure Control Block 2 req'd w/o remote set 3 req'd w/remote set		
58	Cap screw 2 req'd w/o remote set 4 req'd w/remote set		
59	Hex Reducing Nipple (2 req'd)(use only when specified)		

*Recommended spare parts

1. Use to mount Remote Set assembly to Process/Set Point indicator assembly.
2. Use to mount Capsular Element assembly to the Process/Set Point Indicator assembly.

Mounting Parts

Key Description

Pipestand Mounting

- 66 Cap Screw (3 req'd)
- 67 Lock Washer (7 req'd)
- 68 Bracket
- 69 Clamp (2 req'd)

Panel Mounting

- 66 Cap Screw (3 req'd)
- 67 Lock Washer (3 req'd)
- 68 Bracket
- 70 Machine Screw (4 req'd)

Wall Mounting

- 66 Cap Screw (3 req'd)
- 67 Lock Washer (3 req'd)
- 68 Bracket

Actuator Casing Mounting

- Spacer Spool (3 req'd)
- Cap Screw (3 req'd)
- Lockwasher (5 req'd)
- Mounting Bracket
- Cap Screw (2 req'd)
- Mounting Bracket
- Cap Screw (2 req'd)
- Hex Nut (2 req'd)

Description

Actuator Yoke Mounting

- Spacer Spool (3 req'd)
- Cap Screw (3 req'd)
- Lockwasher (5 req'd)
- Mounting Bracket
- Spacer Spool (2 req'd)
- Cap Screw (2 req'd)

Note

Specify quantity of fittings and length of tubing required.

Tubing

- For 1/4 inch O.D.
- For 3/8 inch O.D.

Fittings

- For 1/4 inch or 3/8 inch tubing
- Connector
- Elbow

Figure 5-1. Controller Assembly Drawing

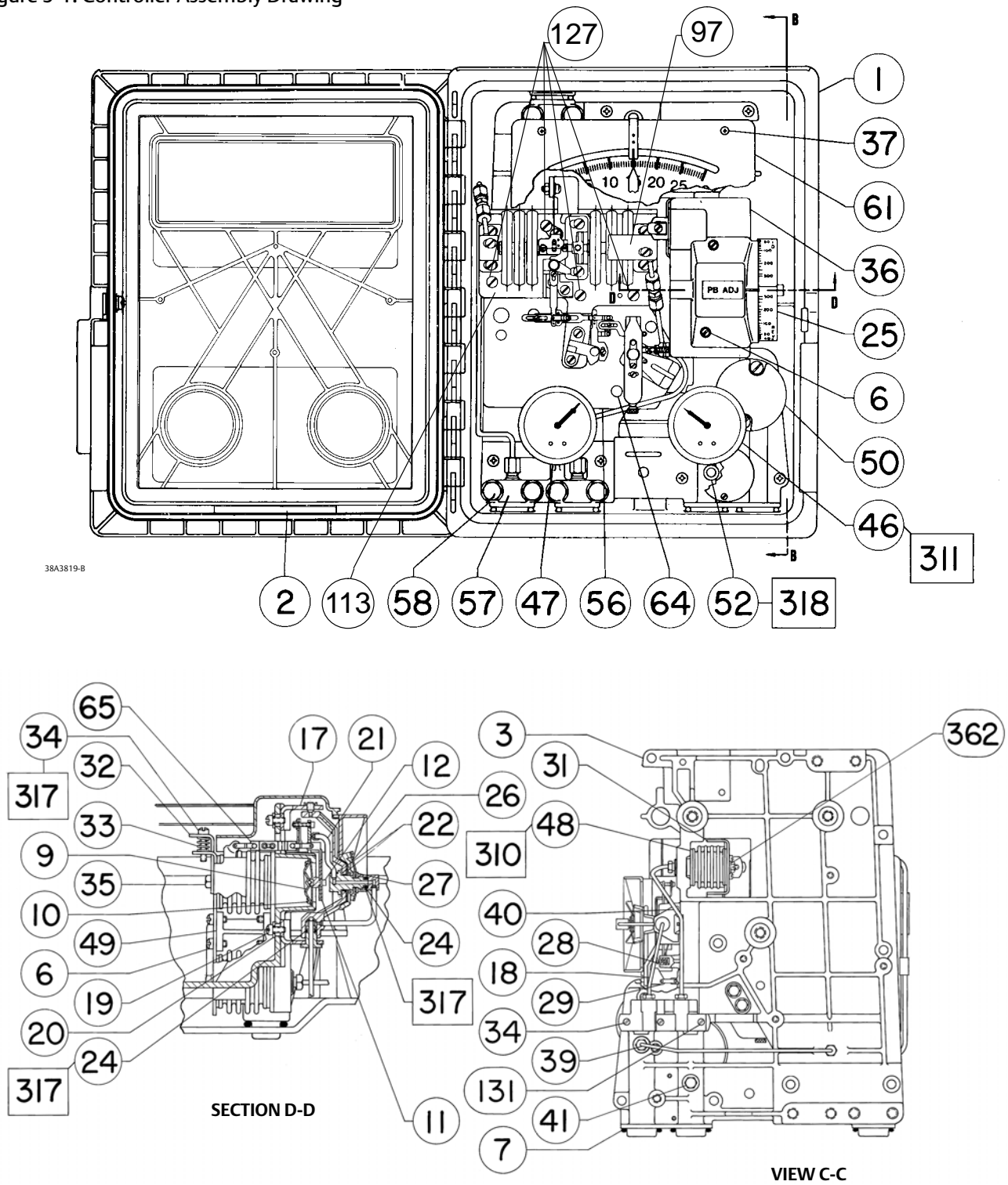

56A9752-V Sht 1

Figure 5-1. Controller Assembly Drawing
(Continued)

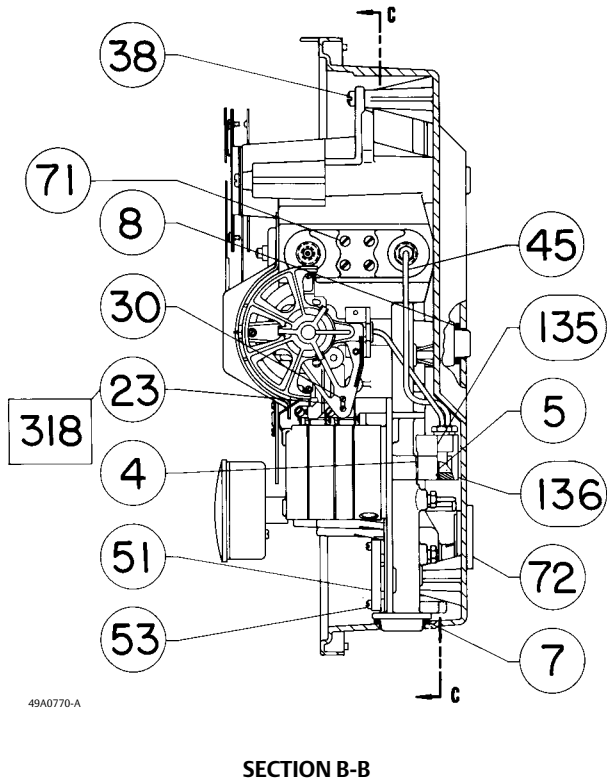

49A0770-A

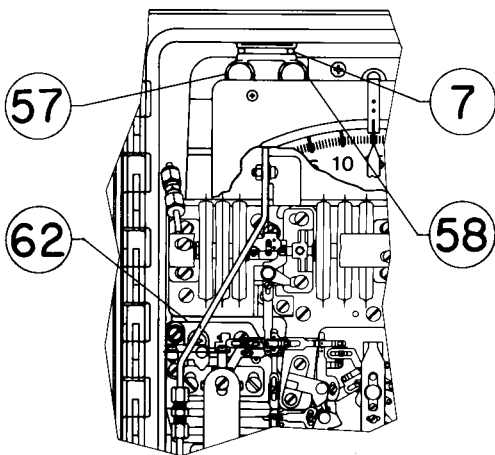

36A3819-A

CONTROLLERS WITH REMOTE SET POINT OPTION

Figure 5-2. Capsular Element Assembly

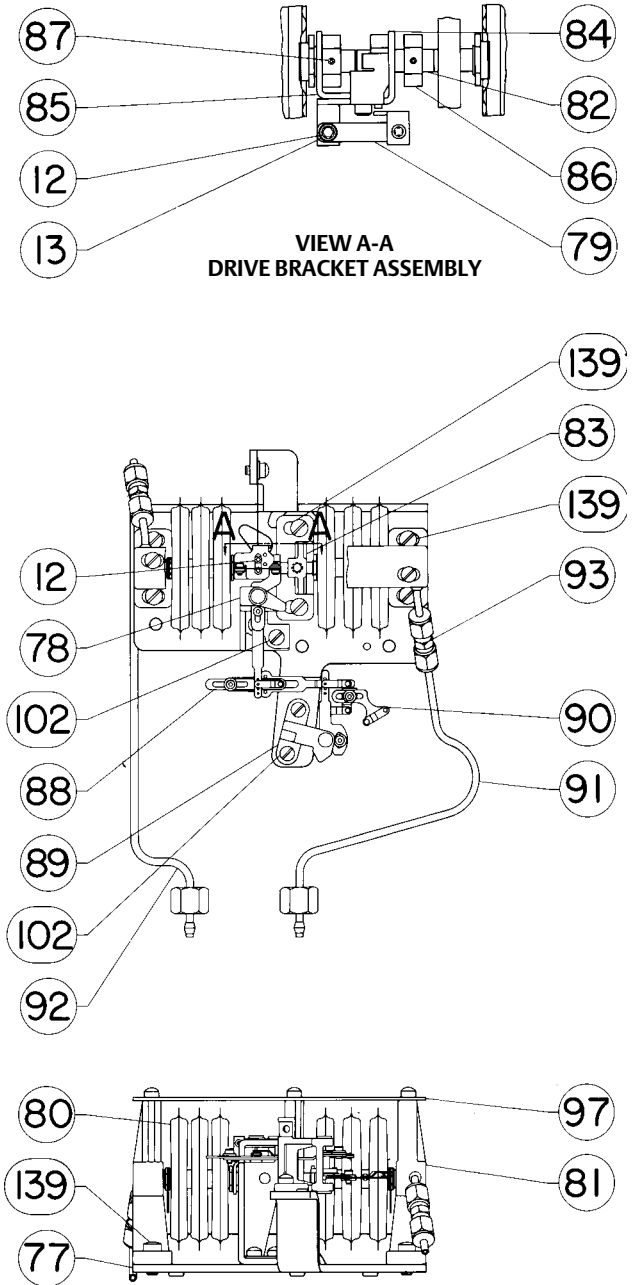

58A0706-C

Figure 5-3. Remote Set Point Assembly Drawing

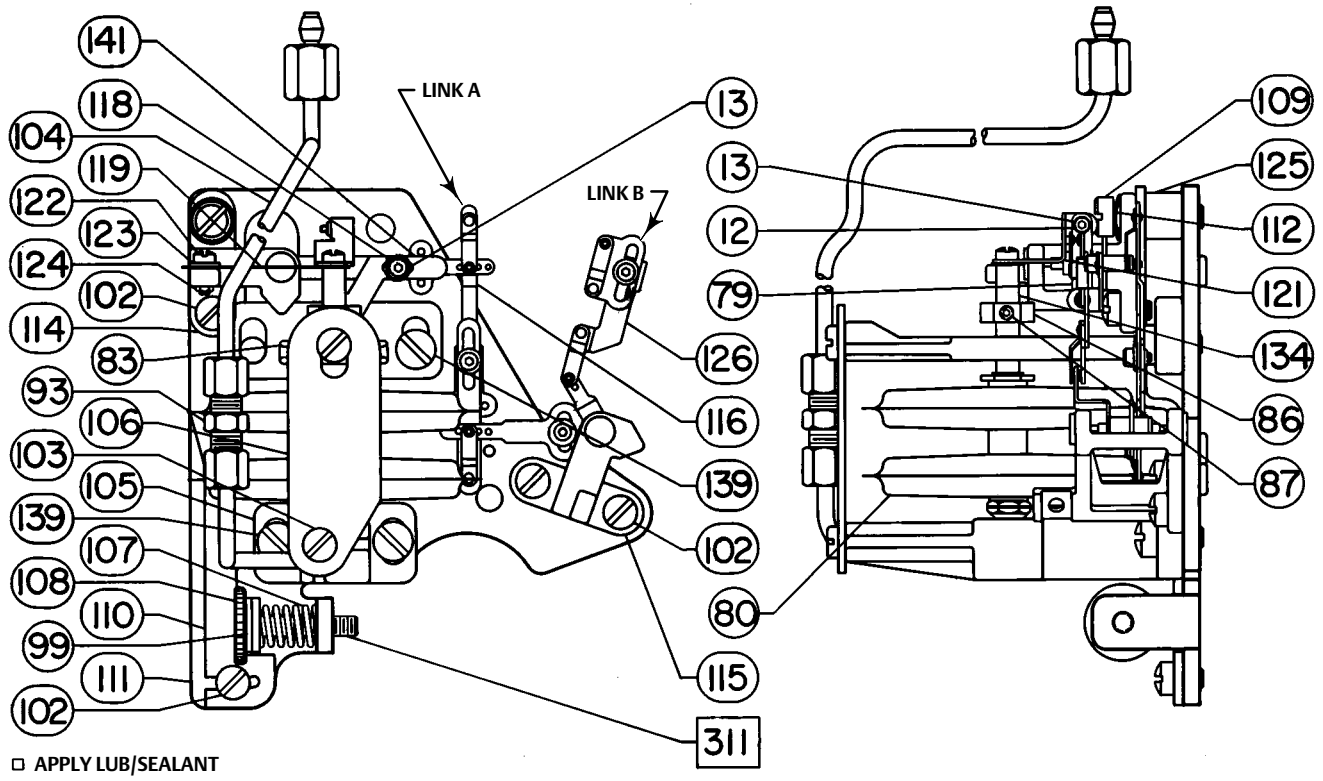

36A6988-C
B1760

Figure 5-4. Auto/Manual Station Parts Location

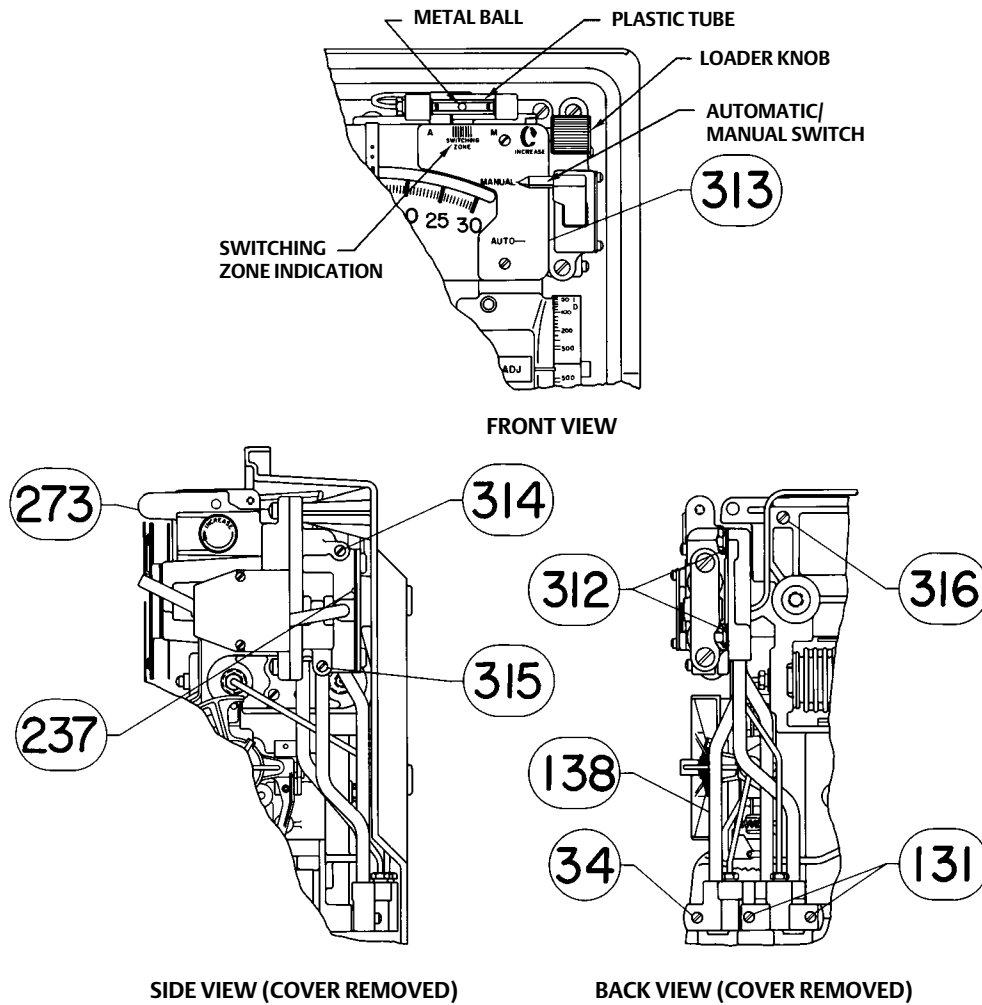

56A9752-D
49A0770-A
C0540

Figure 5-5. Auto/Manual Station Assembly Drawing

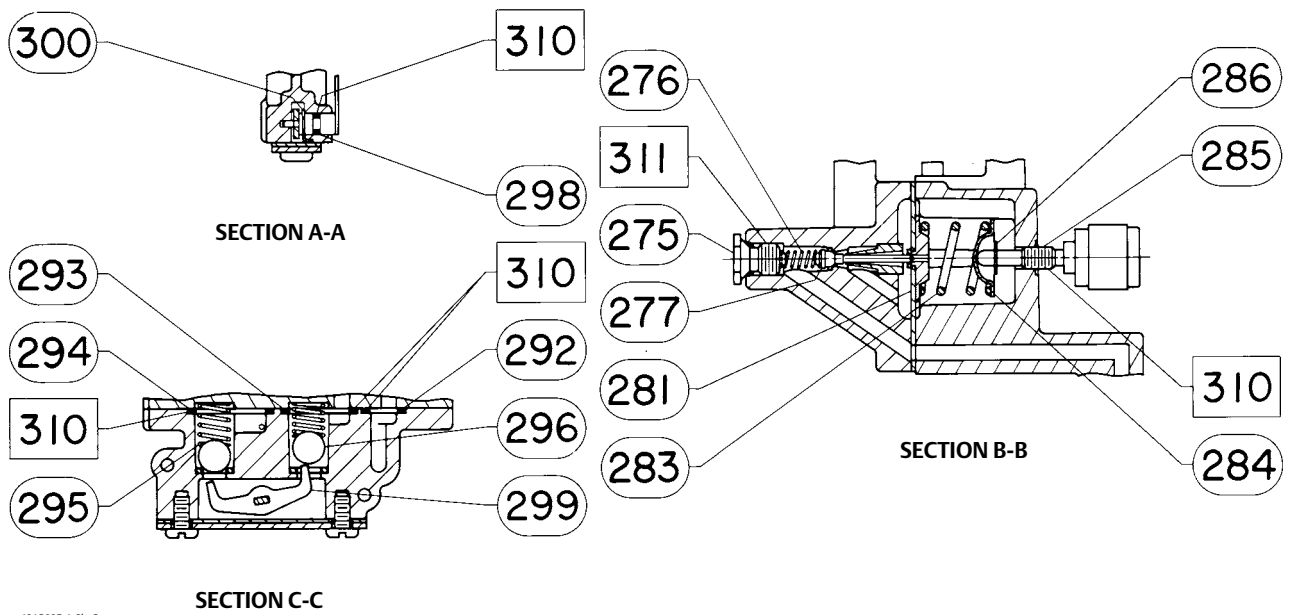
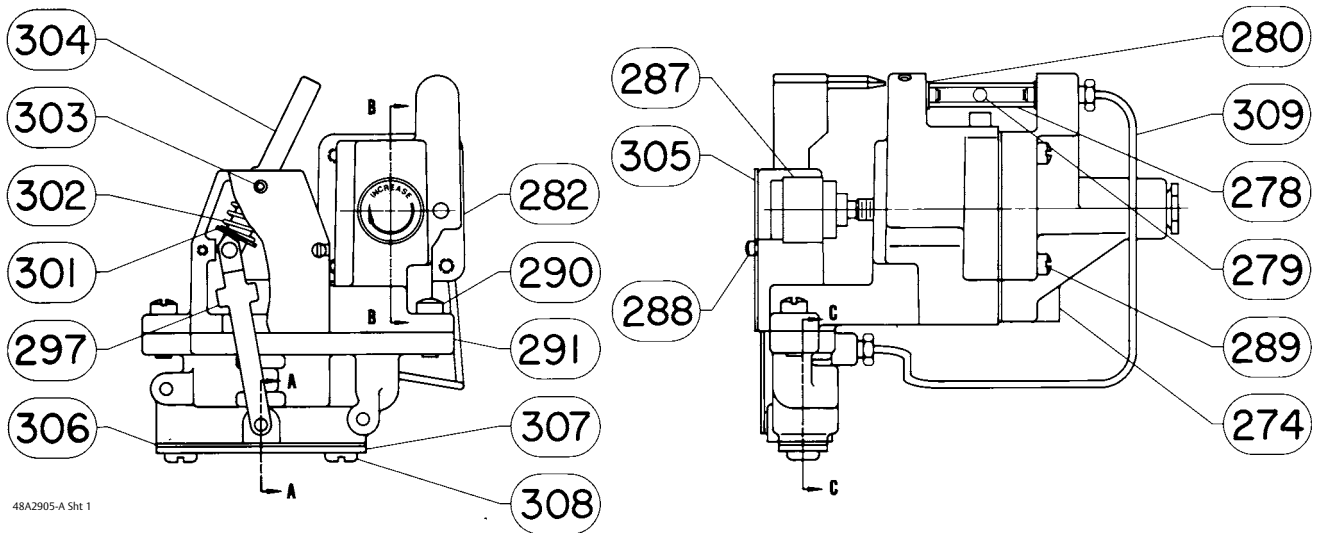
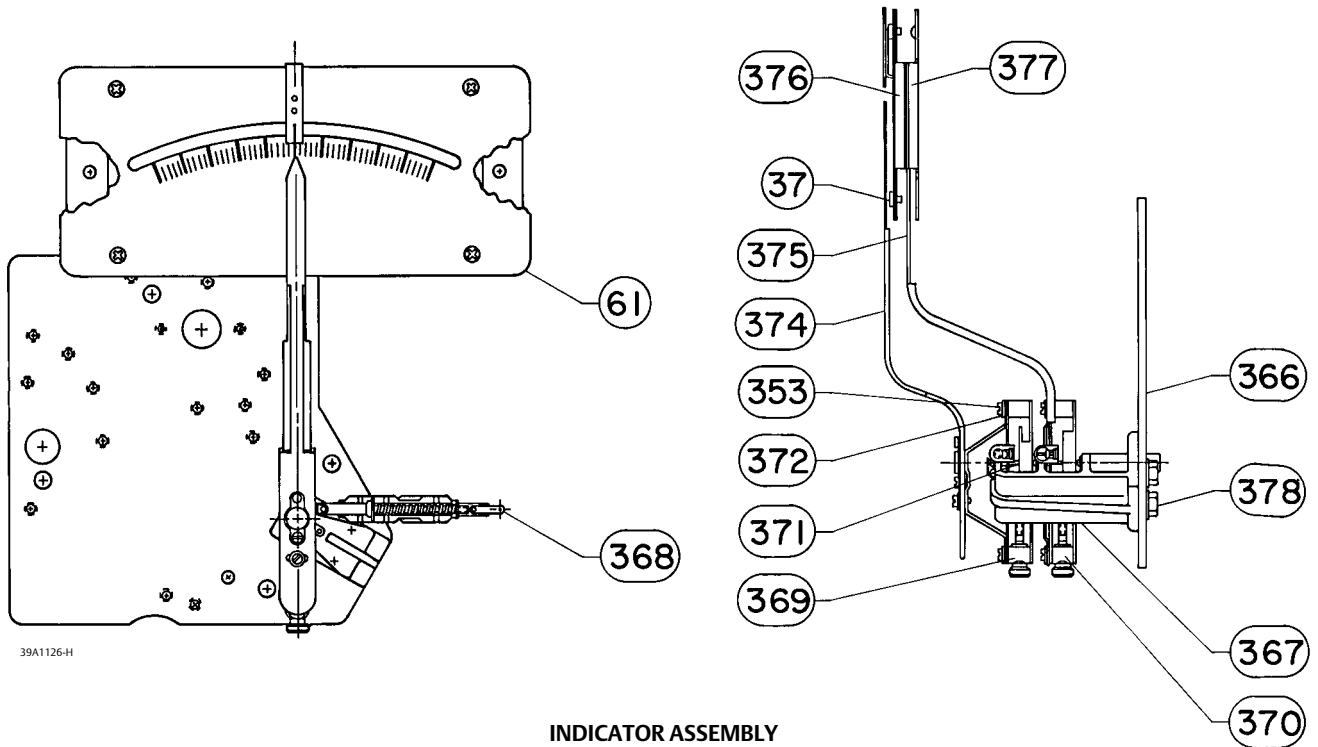
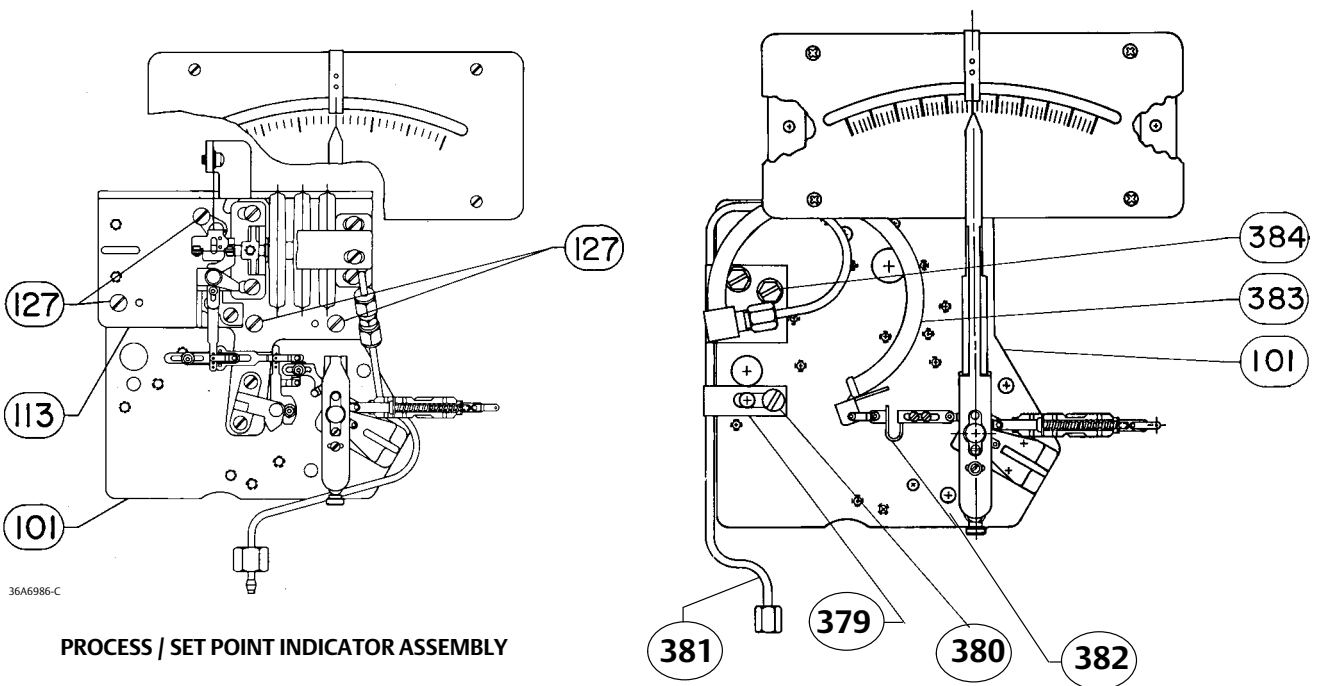

Figure 5-6. Process and Set Point Indicator Assembly (Manual Set Point)



39A1126-H

INDICATOR ASSEMBLY



36A6986-C

PROCESS / SET POINT INDICATOR ASSEMBLY

32B1532-A

PROCESS / SET POINT INDICATOR ASSEMBLY WITH BOURDON TUBE

Neither Emerson, Emerson Automation Solutions, nor any of their affiliated entities assumes responsibility for the selection, use or maintenance of any product. Responsibility for proper selection, use, and maintenance of any product remains solely with the purchaser and end user.

Fisher is a mark owned by one of the companies in the Emerson Automation Solutions business unit of Emerson Electric Co. Emerson Automation Solutions, Emerson, and the Emerson logo are trademarks and service marks of Emerson Electric Co. All other marks are the property of their respective owners.

The contents of this publication are presented for informational purposes only, and while every effort has been made to ensure their accuracy, they are not to be construed as warranties or guarantees, express or implied, regarding the products or services described herein or their use or applicability. All sales are governed by our terms and conditions, which are available upon request. We reserve the right to modify or improve the designs or specifications of such products at any time without notice.

Emerson Automation Solutions
Marshalltown, Iowa 50158 USA
Sorocaba, 18087 Brazil
Cernay, 68700 France
Dubai, United Arab Emirates
Singapore 128461 Singapore

www.Fisher.com

