

# Fisher™ 2502 Controllers



# Table of Contents

## Section 1: Introduction

1.1	Scope of Manual .....	1
1.2	Description .....	1
1.3	Specifications .....	1
1.4	Educational Services .....	1

## Section 2: Installation

2.1	249 Sensors .....	5
2.2	Uncrating .....	6
2.3	Controller Orientation .....	6
2.4	Controller-Sensor Action .....	7
2.5	Mounting Caged Sensor .....	8
2.6	Mounting Cageless Sensor .....	9
2.7	Supply Pressure .....	12
2.8	Vent Assembly .....	12

## Section 3: Prestartup Checks

3.1	Adjustments .....	14
-----	-------------------	----

## Section 4: Calibration

4.1	Precalibration Requirements .....	16
4.2	Calibration Procedure .....	19

## Section 5: Startup .....

20

## Section 6: Principle of Operation

6.1	2502 Controller .....	21
6.2	2502F Controller with Differential Relief Valve .....	23

## Section 7: Maintenance

7.1	Troubleshooting .....	25
7.2	Removing Controller from Sensor .....	26
7.3	Changing Mounting Method .....	28
7.4	Installing Controller on Sensor .....	28
7.5	Changing Proportional, Reset, or Differential Relief Valve .....	29
7.6	Testing Relay Dead Band .....	30
7.7	Changing Relay .....	30
7.8	Replacing Bellows .....	30
7.9	Reversing Action .....	31

**Section 8: Parts**

- 8.1 Parts Ordering..... 33
- 8.2 Parts Kits..... 33
- 8.3 Parts List ..... 34

# Section 1: Introduction

## 1.1 Scope of Manual

This instruction manual provides installation, operating, calibration, and maintenance procedures for Fisher 2502 pneumatic controllers (Figure 1) used in combination with Fisher 249 level sensors.

This manual does not include regulator or sensor installation or maintenance procedures. For this information, refer to the instruction manual for the appropriate regulator and 249 level sensor.

### WARNING



**Do not install, operate or maintain a 2502 controller without being fully trained and qualified in valve, actuator and accessory installation, operation and maintenance. To avoid personal injury or property damage, it is important to carefully read, understand and follow all contents of this manual, including all safety cautions and warnings. If you have any questions about these instructions, contact your [Emerson sales office](#) before proceeding.**

## 1.2 Description

The 2502 controller described in this manual provides proportional-plus-reset and proportional-plus-reset with differential relief valve control. The controller output is a pneumatic signal that operates a final control element. These controllers are designed to control liquid level, the level of interface between two liquids, or density (specific gravity). Each unit consists of a 249 liquid level sensor and a 2502 pneumatic controller.

Refer to Section 6: Principle of Operation for a more comprehensive discussion of how the 2502 pneumatic controller operates.

## 1.3 Specifications

Table 1 gives general specifications for 2502 controllers.

## 1.4 Educational Services

Emerson Educational Services  
Phone: +1-800-338-8158  
e-mail: [education@emerson.com](mailto:education@emerson.com)  
[emerson.com/mytraining](http://emerson.com/mytraining)

**Table 1. Specifications**

Available Configuration	Supply Medium (continued)				
<p>2502: A direct-acting controller which provides proportional-plus-reset control</p> <p>2502F: A 2502 with a differential relief valve</p> <p>These products are also available with reverse action. For example, 2502R and 2502FR</p>	<p><b>Per ISO 8573-1</b></p> <p>Maximum particle density size: Class 7</p> <p>Oil content: Class 3</p> <p>Pressure Dew Point: Class 3</p>				
Input Signal	Supply Pressure Requirement				
<p>Liquid Level or Liquid-to-Liquid Interface Level: From 0 to 100 percent of displacer length—standard lengths for all sensors are 356 mm / 14 inches or 813 mm / 32 inches. Other lengths available depending on sensor construction</p> <p>Liquid Density: From 0 to 100 percent of displacement force change obtained with given displacer volume—standard volumes are 980 cm<sup>3</sup> / 60 inches<sup>3</sup> for 249C and 249CP sensors, or 1640 cm<sup>3</sup> / 100 inches<sup>3</sup> for most other 249 sensors; other volumes available depending on construction</p>	<p>1.4 bar<sup>(1)</sup> / 20 psig for 0.2 to 1.0 bar / 3 to 15 psig output signal or 2.4 bar<sup>(1)</sup> / 35 psig for 0.4 to 2.0 bar / 6 to 30 psig output signal</p> <tr> <th data-bbox="857 785 1427 842">Maximum Supply Pressure<sup>(2)</sup></th> <td data-bbox="857 842 1427 911"> <p>3.4 bar / 50 psig</p> </td> </tr> <tr> <th data-bbox="857 911 1427 982">Supply Pressure Consumption<sup>(3)</sup></th> <td data-bbox="857 982 1427 1314"> <p>At 1.4 bar (20 Psig)</p> <p>Minimum: 0.11 normal m<sup>3</sup>/h / 4.2 scfh at proportional band setting of 0 or 200 percent</p> <p>Maximum: 0.72 normal m<sup>3</sup>/h / 27 scfh at proportional band setting of 100 percent</p> <p>At 2.4 bar / 35 psig</p> <p>Minimum: 0.2 normal m<sup>3</sup>/h / 7 scfh at proportional band setting of 0 or 200 percent</p> <p>Maximum: 1.1 normal m<sup>3</sup>/h / 42 scfh at proportional band setting of 100 percent</p> </td> </tr>	Maximum Supply Pressure <sup>(2)</sup>	<p>3.4 bar / 50 psig</p>	Supply Pressure Consumption <sup>(3)</sup>	<p>At 1.4 bar (20 Psig)</p> <p>Minimum: 0.11 normal m<sup>3</sup>/h / 4.2 scfh at proportional band setting of 0 or 200 percent</p> <p>Maximum: 0.72 normal m<sup>3</sup>/h / 27 scfh at proportional band setting of 100 percent</p> <p>At 2.4 bar / 35 psig</p> <p>Minimum: 0.2 normal m<sup>3</sup>/h / 7 scfh at proportional band setting of 0 or 200 percent</p> <p>Maximum: 1.1 normal m<sup>3</sup>/h / 42 scfh at proportional band setting of 100 percent</p>
Maximum Supply Pressure <sup>(2)</sup>	<p>3.4 bar / 50 psig</p>				
Supply Pressure Consumption <sup>(3)</sup>	<p>At 1.4 bar (20 Psig)</p> <p>Minimum: 0.11 normal m<sup>3</sup>/h / 4.2 scfh at proportional band setting of 0 or 200 percent</p> <p>Maximum: 0.72 normal m<sup>3</sup>/h / 27 scfh at proportional band setting of 100 percent</p> <p>At 2.4 bar / 35 psig</p> <p>Minimum: 0.2 normal m<sup>3</sup>/h / 7 scfh at proportional band setting of 0 or 200 percent</p> <p>Maximum: 1.1 normal m<sup>3</sup>/h / 42 scfh at proportional band setting of 100 percent</p>				

Output Signal	0.2 to 1.0 bar / 3 to 15 psig or 0.4 to 2.0 bar / 6 to 30 psig  Action: Field reversible between direct (increasing liquid or interface level or specific gravity increases output pressure) and reverse (increasing liquid or interface level or specific gravity decreases output pressure)
Area Ratio of Relay Diaphragms	3:1
Supply Medium	Air or Natural Gas  Supply medium must be clean, dry, and noncorrosive  **Per ISA Standard 7.0.01**  A maximum 40 micrometer particle size in the air system is acceptable. Further filtration down to 5 micrometer particle size is recommended. Lubricant content is not to exceed 1 ppm weight (w/w) or volume (v/v) basis. Condensation in the air supply should be minimized  Pressure Dew Point: at least 10 °C less than the lowest ambient temperature expected
Performance	Hysteresis: 0.6 percent of output pressure change at 100 percent of proportional band  Repeatability: 0.2 percent of displacer length or displacement force change  Dead Band: 0.05 percent of proportional band or span  Typical Frequency Response: 4 Hz and 90-degree phase shift at 100 percent of proportional band with output piped to typical instrument bellows using 6.1 meters / 20 feet of 6.4 mm / 1/4 in. tubing  Ambient Temperature Error: +/- 1.5 percent of output pressure change per 50 °F / 28 °C of temperature change at 100 percent of proportional band when using sensor with standard-wall N05500 torque tube with 249 sensors  Reset: Adjustable from 0.01 to 74 minutes per repeat / 100 to 0.01 repeats per minute

-continued-

**Table 1. Specifications (continued)**

Performance (continued)	Ambient Operative Temperatures <sup>(2)</sup>
Differential Relief (2502F and 2502FR Controllers Only): Adjustable from 0.1 to 0.48 bar differential / 2 to 7 psi to relieve excessive difference between proportional and reset pressures.  Differential relief can be switched between rising output pressure and falling output pressure.	Standard Construction: -40 to 71 °C / -40 to 160 °F High Temperature Construction: -18 to 104 °C / 0 to 220 °F  See Figure 2
Standard Tubing Connections	Declaration of SEP
1/4 NPT internal	Fisher Controls International LLC declares this product to be in compliance with Article 4, paragraph 3 of the PED Directive 2014/68/EU and Part 1, Requirement 8 of the PESR Regulation. It was designed and manufactured in accordance with Sound Engineering Practice (SEP) and cannot bear the CE marking related to PED compliance or the UKCA mark related to the PESR Regulation.  However, the product may bear the CE or UKCA marking to indicate compliance with other applicable European Community Directives or UK Regulations (Statutory Instruments).
Maximum Working Pressures (Sensors Only)	
Consistent with applicable ASME pressure/temperature ratings	
Hazardous Area Classification	
2502 controllers comply with the requirements of ATEX Group II Category 2 Gas and Dust    Maximum surface temperature (Tx) depends on operating conditions  Gas: T4, T5, T6 Dust: T85...T104	
<b>NOTE:</b> Specialized instrument terms are defined in ANSI/ISA Standard 51.1 - Process Instrument Terminology.	
1. Control and stability may be impaired if this pressure is exceeded. 2. The pressure/temperature limits in this document, and any applicable standard or code limitation should not be exceeded. 3. Normal cubic meters per hour (m <sup>3</sup> /hr) at 0 °C and 1.01325 bar. Scfh=standard cubic feet per hour at 60 °F and 14.7 psia	

**Figure 1. Fisher 2502 Controller Mounted on 249B Sensor**

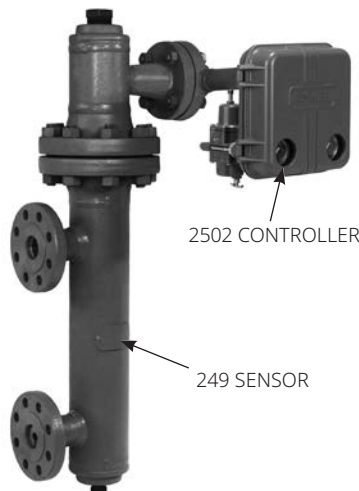

**Figure 2. Guidelines for Use of Optional Heat Insulator Assembly**

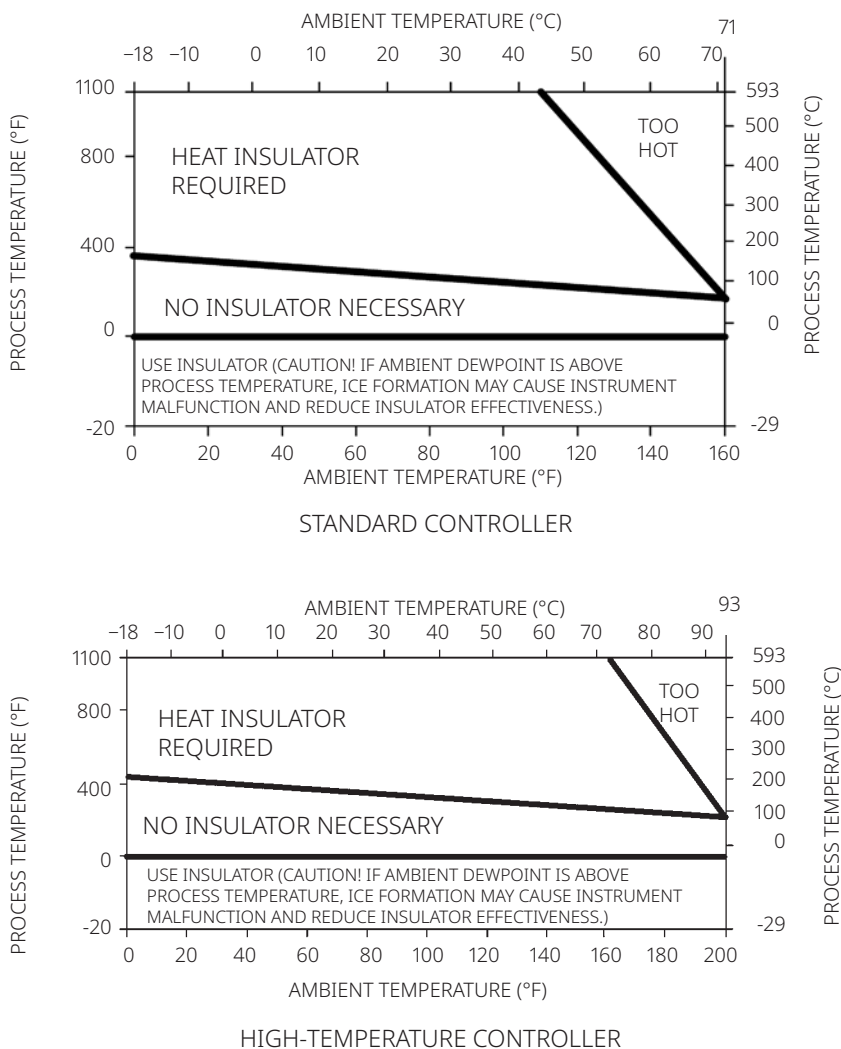

NOTE:  
FOR SERVICE BELOW -29 °C / -20 °F, CONTACT FACTORY.  
B1413-1

## Section 2: Installation

2502 controllers are used in combination with 249 sensors, and unless ordered separately, the controller will be attached to the sensor.

### **⚠ WARNING**

**Always wear protective clothing, gloves, and eyewear when performing any installation operations to avoid personal injury.**

**Check with your process or safety engineer for any additional measures that must be taken to protect against process media.**

If installing into an existing application, also refer to the **WARNING** at the beginning of the Maintenance section in this instruction manual.

---

### **WARNING**

Personal injury or property damage may result from fire or explosion if natural gas is used as the supply medium and preventive measures are not taken. Preventive measures may include, but are not limited to, one or more of the following: Remote venting of the unit, re-evaluating the hazardous area classification, ensuring adequate ventilation, and the removal of any ignition sources. For information on remote venting of this controller refer to 2.8 Vent Assembly.

---

### **NOTICE**

Do not use sealing tape on pneumatic connections. This instrument contains small passages that may become obstructed by detached sealing tape. Thread sealant paste should be used to seal and lubricate pneumatic threaded connections.

---

## 2.1 249 Sensors

- 249B, 249BF, 249C, 249K, and 249L sensors side-mount on the vessel with the displacer mounted inside a cage (caged) outside the vessel.
- 249BP and 249CP sensors top-mount on the vessel with the displacer hanging down into the vessel (cageless).
- The 249VS sensor side-mounts on the vessel with the displacer hanging out into the vessel (cageless).
- The 249W sensor top-mounts on the vessel or on a customer supplied cage.

External sensors provide more stable operation than do internal sensors for vessels with internal obstructions or considerable internal turbulence.

### **WARNING**

When replacing the sensor assembly, the displacer may retain process liquid or pressure. Personal injury or property damage due to sudden release of pressure, contact with hazardous liquid, fire, or explosion can be caused by puncturing, heating, or repairing a displacer that is retaining process pressure or liquid. This danger may not be readily apparent when disassembling the sensor or removing the displacer. Before disassembling the sensor or removing the displacer, observe the more specific warning provided in the sensor instruction manual.

---



## 2.2 Uncrating

Unless ordered separately, the controller will be attached to the sensor when shipped. Carefully uncrate the assembly

### NOTICE

**If the sensor has a thin-walled torque tube, always support the displacer if the travel stop must be removed. A thin-walled torque tube has a T stamped on the sensor end flange (not visible unless the controller is removed from the sensor).**

### NOTE

Caged sensors have a rod and block installed on each end of the displacer to protect the displacer in shipping. Remove these parts before installing the sensor to allow the displacer to function properly.

Caged sensors will be shipped with the displacer installed in the cage. If the sensor is ordered with a tubular gauge glass, the gauge glass will be crated separately and must be installed at the site. Be certain that the cage equalizing connections are not plugged with foreign material.

A caged sensor has a damping plate installed in the lower screwed or flanged connection to provide more stable operation. If the process liquid could clog the plate opening with sediment, then remove the damping plate. For screwed connections, use a 1/2-in. hexagon wrench to unscrew the damping plate. For flanged connections, use a screwdriver to pry the damping plate out of the flange.

A cageless sensor is shipped with the displacer separated from the sensor assembly. A displacer longer than 813 mm / 32 inches is crated separately. A shorter displacer is crated with the sensor, but is not attached to the displacer rod. Inspect the displacer and replace if it is dented. A dent may reduce the pressure rating of the displacer.

## 2.3 Controller Orientation

A controller is to be mounted with the vent opening pointing downward as shown in Figure 3. This orientation is necessary to ensure draining of accumulated moisture. The controller is attached to the sensor in one or the other of the mounting positions shown in Figure 4: Right hand (with the case to the right of the displacer when looking at the front of the case) or left hand (with the case to the left of the displacer). The mounting position can be changed in the field if required; refer to the appropriate sensor manual for instructions. Changing this mounting position will change controller action from direct to reverse, or vice versa.

All caged sensors have a rotatable head. That is, the controller may be positioned at any of eight alternate positions around the cage as indicated by the numbers 1 through 8 in Figure 4. To rotate the head, remove the head flange bolts and nuts and position the head as desired.

Figure 3. Pressure Connections

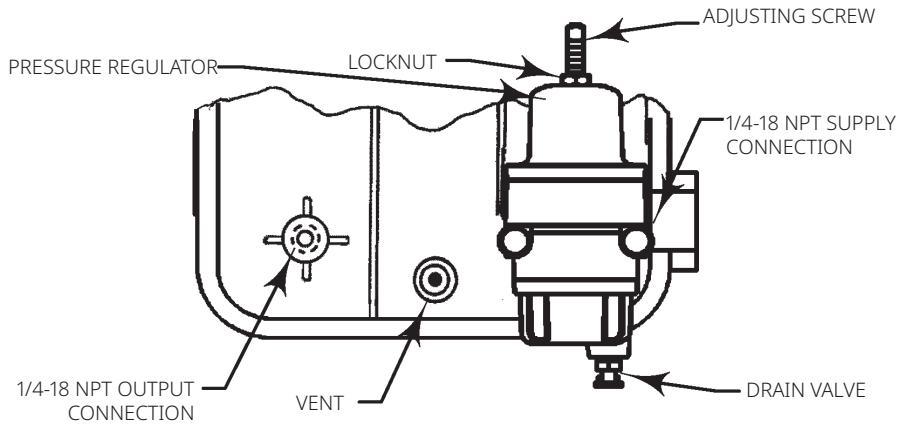
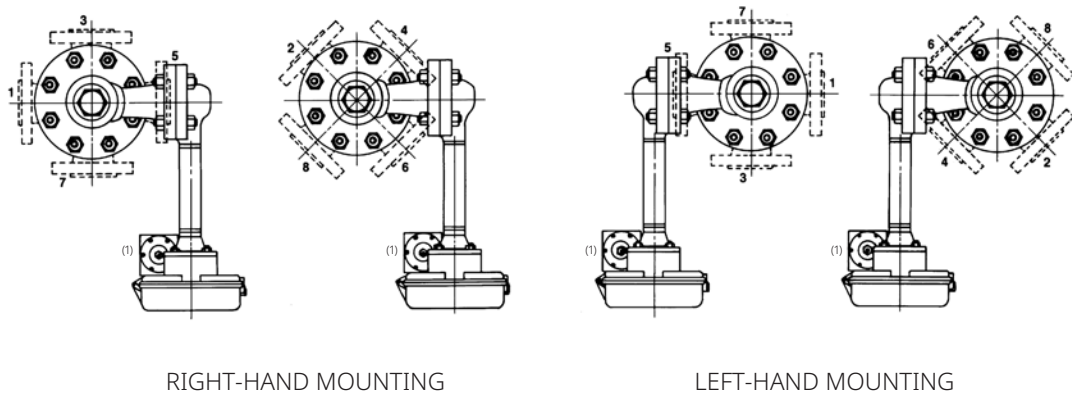

Figure 4. Cage Head Mounting Positions



1. 67CFR FILTER/REGULATOR  
AH9150-A  
A2613-2

## 2.4 Controller-Sensor Action

The following controller description is for right-hand mounting. Left-hand mounting produces an output signal with the opposite action. Figure 4 shows cage head mounting positions.

For right-hand mounting:

- Direct Action—Increasing liquid or interface level, or density, increases the output signal.
- Reverse Action—Decreasing liquid or interface level, or density, increases the output signal. A factory-supplied reverse-acting unit has the suffix letter R added to the type number.

## 2.5 Mounting Caged Sensor

---

### NOTE

The cage must be installed plumb so that the displacer does not touch the cage wall. Should the displacer touch the cage wall, the unit will transmit an erroneous output signal.

---

### NOTE

If the controller is not mounted on the sensor, refer to Section 7.4: Installing Controller on Sensor. This section also provides instructions for adding a heat insulator to a unit.

---

Cage connections will normally be either NPS 1-1/2 or 2 screwed or flanged. Figure 5 shows the combinations. With flanged connections, use standard gaskets or other flat-sheet gaskets compatible with the process liquid. Spiral wound gaskets without compression-controlling centering rings cannot be used for flanged connections.

Mount the cage by running equalizing lines between the cage connections and the vessel (Figure 6). A shutoff or hand valve with a 1-1/2 in. diameter or larger port should be installed in each of the equalizing lines. Also install a drain between the cage and shutoff or hand valve whenever the bottom cage line has a liquid-trapping low point.

On liquid or interface level applications, position the sensor so that the line marked FLOAT CENTER on the cage is located as close as possible to the center of the liquid level or interface level range being measured. Also consider installing a gauge glass either on the vessel, or on the sensor cage (if the cage is tapped for a gauge).

---

**Figure 5. Cage Connection Styles**

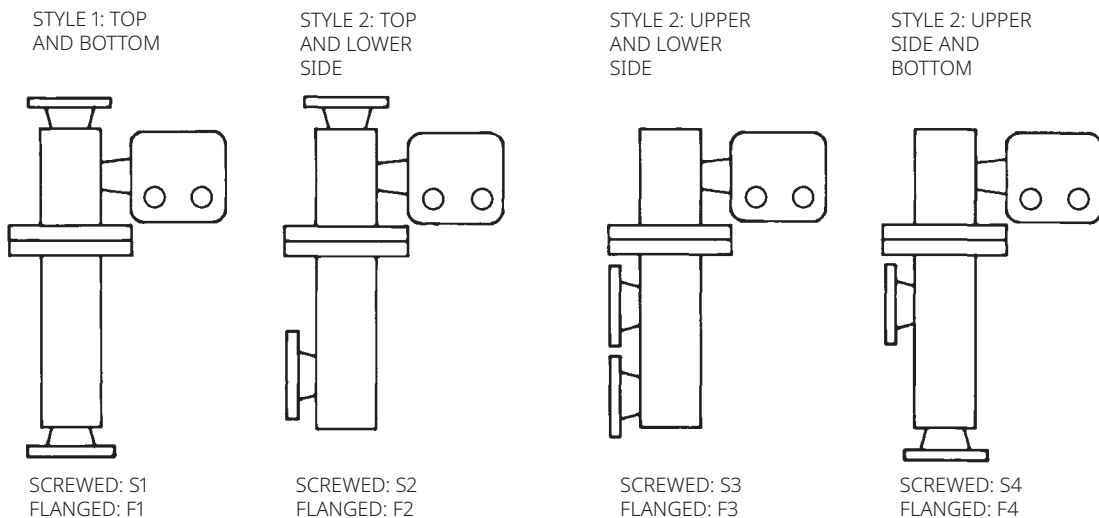

A1271-2

Figure 6. Caged Sensor Mounting

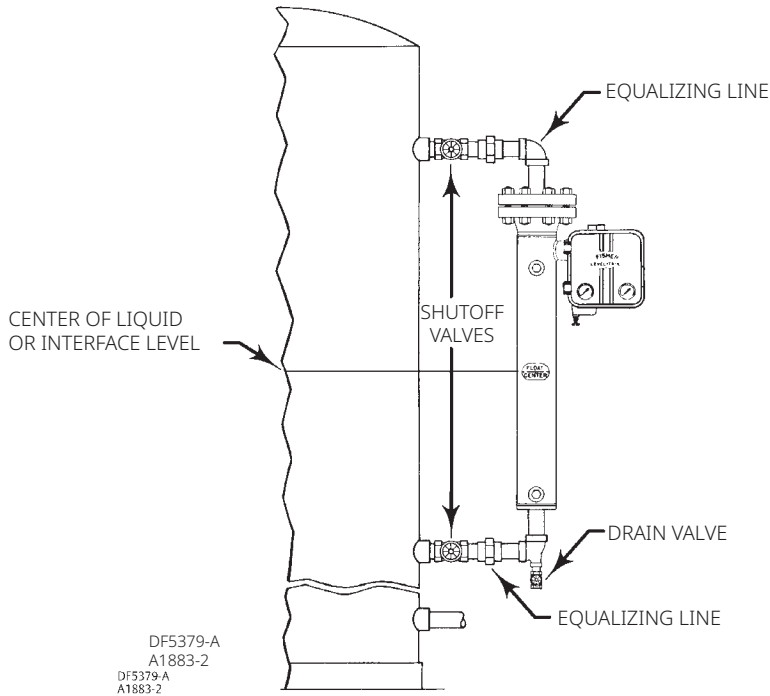

## 2.6 Mounting Cageless Sensor

### NOTE

If a stillwell is used, it must be installed plumb so that the displacer does not touch the wall of the stillwell. Should the displacer touch the wall while the unit is in service, the unit will transmit an erroneous output signal.

Since the displacer hangs inside the vessel, provide a stillwell around the displacer if the liquid is in a state of continuous agitation to avoid excessive turbulence around the displacer.

### NOTE

Displacers used in an interface level application must be completely submerged during operation. If displacers aren't completely submerged they will not calibrate or perform properly. To obtain the desired controller sensitivity may require using either a thin-wall torque tube, an oversized displacer, or both.

### NOTE

If the controller is not mounted on the sensor, refer to Section 7.4: Installing Controller on Sensor. This section also provides instructions for adding a heat insulator to a unit.

**Figure 7. Cageless Sensor Mounting**

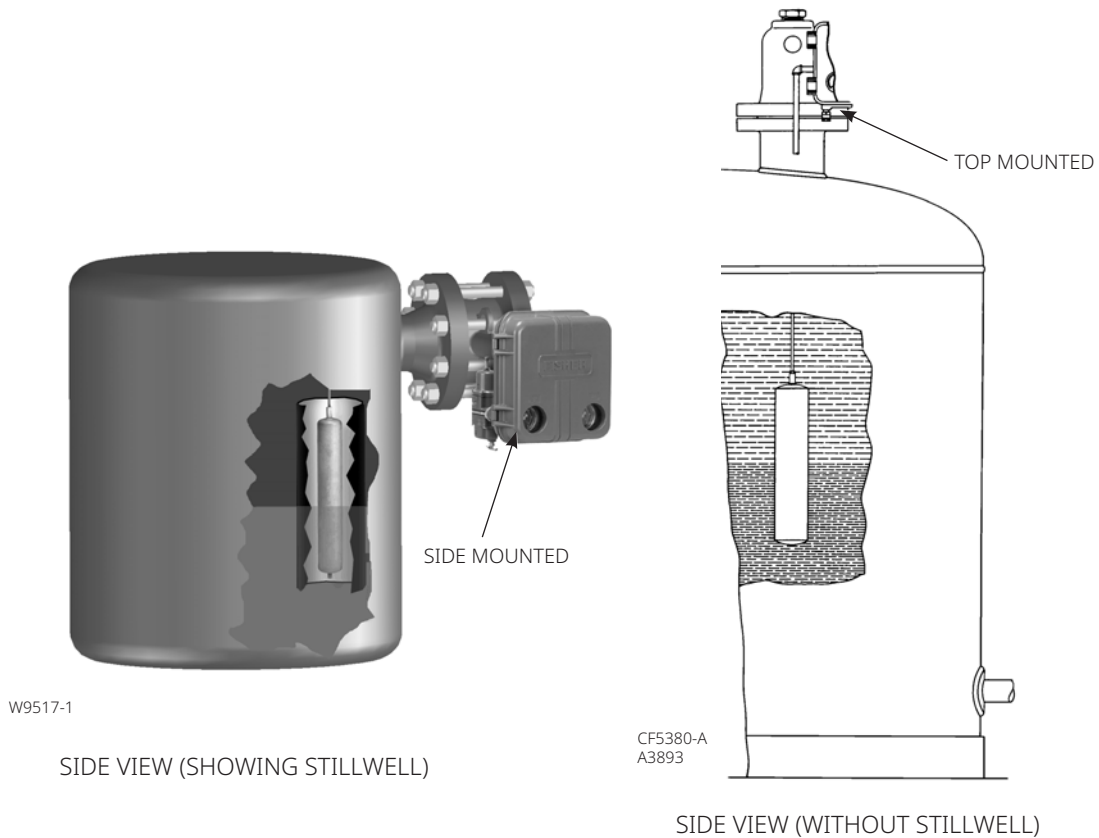

Attach a cageless sensor to a flanged connection on the vessel as shown in Figure 7. For interface or liquid level applications, install a gauge glass on the vessel.

**NOTICE**

**If the displacer is to be inserted into the vessel before being attached to the displacer rod, provide a suitable means of supporting the displacer to prevent it from dropping into the vessel and suffering damage.**

To help support a 249BP or 249CP displacer, install the displacer stem and stem end piece, or a threaded rod, into the 1/4 in.-28 UNF threaded hole in the displacer spud or stem end piece (Figure 8). On the 249BP with optional travel stop, the stem end piece pins will secure the displacer as long as the travel stop plate is installed and the sensor head is in position.

### Side-Mounted Sensor

If a stillwell is required (Figure 7), the displacer must be attached to the displacer rod from inside the vessel. Connect the displacer as shown in Figure 8, locking the assembly with the cotter spring provided. If a stillwell is not required, the displacer can be attached to the displacer rod before mounting the sensor to the vessel connection. The displacer may then be swung out horizontally for insertion into the vessel. However, once the sensor is installed and the displacer drops to a vertical position, the displacer may not be capable of being withdrawn for servicing later. Be sure there is another access to the displacer to permit swinging it to a horizontal position or to permit disconnecting it from the displacer rod.

If an extension is used between the displacer spud and the displacer stem end piece, make sure the nuts are tight at each end of the displacer stem extension. Install and tighten suitable bolting or cap screws in the flanged connection to complete the installation.

### Top Mounted Sensor

Figure 7 shows the installation of a top-mounted cageless sensor. The displacer may be attached to the displacer rod before installing the sensor on the vessel. Where the displacer diameter is small enough, it may be desirable to install a long or sectionalized displacer through the sensor head access hole after the sensor is installed on the vessel. Connect the displacer as shown in Figure 8, locking the assembly with the cotter springs provided. If a stem is used between the displacer as shown in Figure 8, lock the assembly with the cotter springs provided. If a stem is used between the displacer spud and the stem end piece, make sure the nuts are tight at each end of the stem. Install and tighten suitable cap screws in the flanged connection to complete the installation.

**Figure 8. Displacer and Displacer Rod Connections**

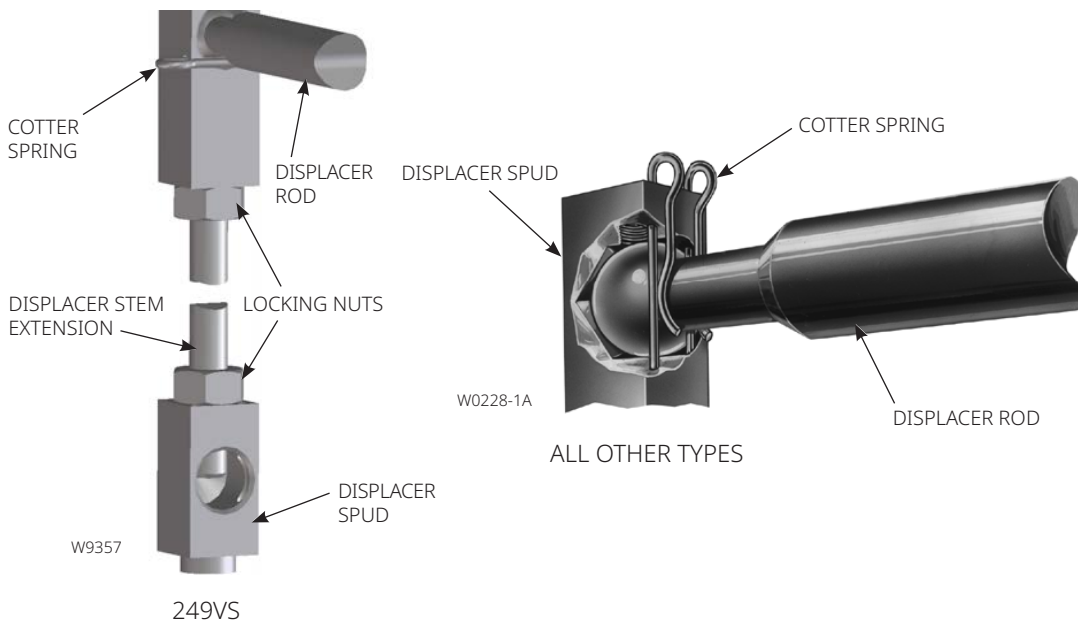

## 2.7 Supply Pressure

### WARNING

**Do not overpressurize any system component. Personal injury or property damage may occur due to sudden pressure release or explosion. To avoid damage, provide suitable pressure-relieving or pressure limiting devices if supply pressure can exceed the maximum supply pressure listed in Table 1.**

**Personal injury or property damage may occur from an uncontrolled process if the supply medium is not clean, dry, oil-free, or non-corrosive gas. While use and regular maintenance of a filter that removes particles larger than 40 micrometers in diameter will suffice in most applications, check with an Emerson field office and industry instrument air quality standards for use with corrosive gas or if you are unsure about the proper amount or method of air filtration or filter maintenance.**

### NOTICE

**Do not use sealing tape on pneumatic connections. This instrument contains small passages that may become obstructed by detached sealing tape. Thread sealant paste should be used to seal and lubricate pneumatic threaded connections.**

Standard 2502 controllers come complete with supply and output pressure gauges and an integrally mounted 67CFR filter regulator to reduce supply pressure from a maximum of 17.3 bar / 250 psig to the 1.4 or 2.4 bar / 20 or 35 psig required. This regulator has built-in relief and a standard 5-micrometer filter to remove particles from the supply source.

The output pressure connection is on the back of the controller case (Figure 3). Pipe the supply pressure to the in connection of the regulator mounted to the case back. Provide a clean, dry, and noncorrosive air or gas supply to the controller.

After pressure connections have been made, turn on the supply pressure and check all connections for leaks.

## 2.8 Vent Assembly

### WARNING

**Personal injury or property damage could result from fire or explosion of accumulated gas, or from contact with hazardous gas, if a flammable or hazardous gas is used as the supply pressure medium. Because the instrument case and cover assembly do not form a gas-tight seal when the assembly is enclosed, a remote vent line, adequate ventilation, and necessary safety measures should be used to prevent the accumulation of flammable or hazardous gas. However, a remote vent pipe alone**

**cannot be relied upon to remove all flammable and hazardous gas. Vent line piping should comply with local and regional codes, and should be as short as possible with adequate inside diameter and few bends to reduce case pressure buildup.**

---

## NOTICE

**When installing a remote vent pipe, take care not to overtighten the pipe in the vent connection. Excessive torque will damage the threads in the connection.**

---

The vent assembly (see Figure 3) or the end of a remote vent pipe must be protected against the entrance of all foreign matter that could plug the vent. Use 13 mm / 1/2-in. pipe for the remote vent pipe, if one is required. Check the vent periodically to be certain it has not become plugged.

## Section 3: Prestartup Checks

### WARNING

**The following procedure requires taking the controller out of service. To avoid personal injury and property damage caused by an uncontrolled process, provide some temporary means of control for the process before taking the controller out of service.**

---

Adjustment locations are shown in Figure 9 unless otherwise indicated. When performing the checks open loop conditions must exist. To obtain open-loop conditions:

- make sure there is no process flow through the final control element, or
- disconnect the controller output signal line and plug the output connection.

During startup, it is necessary to change process levels to position the displacer from its maximum to its minimum range of operations. Provide a means to change the process level or interface. If the process variable cannot be varied sufficiently, follow the instructions in Section 4: Calibration to simulate the process variable changes required for these checks.

Make sure that the RAISE LEVEL dial on the controller is mounted with the correct side facing out. The dial is printed on both sides with the arrow on one side pointing to the left and the arrow on the other side pointing to the right. Figure 9 shows the dial arrow positioned for a sensor that is mounted to the left of the controller; the arrow points to the left. If the sensor is to the right of the controller, remove the two mounting screws, turn the dial over so the arrow points to the right, then reinstall the mounting screws.

1. Turn on the supply pressure and check that the controller supply gauge reads 1.4 bar / 20 psig for a 0.2 to 1.0 bar / 3 to 15 psig output pressure range or 2.4 bar / 35 psig for a 0.4 to 2.0 bar / 6 to 30 psig output pressure range. If the pressure is incorrect, loosen the locknut of the filter/regulator (Figure 3); turn the adjusting screw clockwise to increase or counterclockwise to decrease pressure. Tighten the locknut after setting the pressure.



2. Turn the reset control to .05 minutes per repeat.
3. Locate the process variable at its minimum value (see Table 2). Zero the proportional band and raise level controls. Output pressure on direct-acting controllers should be greater than zero but less than 0.2 bar / 3 psig for the 0.2 to 1.0 bar / 3 to 15 psig range or 0.4 bar / 6 psig for the 0.4 to 2.0 bar / 6 to 30 psig range. For reverse-acting controllers, the output pressure should be greater than 1.0 bar / 15 psig and less than 1.4 bar / 20 psig for the 0.2 to 1.0 bar / 3 to 15 psig range or greater than 30 psig / 2.0 bar and less than 3.4 bar / 35 psig for the 0.4 to 2.0 bar / 6 to 30 psig range. If these conditions are not met recalibration may be desired.
4. Locate the process variable at its maximum value (see Table 2). Output pressure on direct-acting controllers should be greater than 1.0 bar / 15 psig and less than 1.4 bar / 20 psig for the 0.2 to 1.0 bar / 3 to 15 psig range or greater than 2.0 bar / 30 psig and less than 3.4 bar / 35 psig) for the 0.4 to 2.0 bar / 6 to 30 psig range. If these conditions are not met, recalibration may be desired.
5. If all prestartup checks are satisfactory proceed to the Section 5: Startup.

## 3.1 Adjustments

Controller adjustments are provided in this section. Refer to Figure 9 for adjustment locations.

### Level Set Adjustment

To perform the level adjustment, open the controller cover, loosen the knurled adjustment screw (see Figure 9), and rotate the adjustment lever around the RAISE LEVEL dial. To raise the fluid or interface level, or increase density, rotate this knob in the direction of the arrows. To lower the level or decrease density, rotate the knob in the opposite direction. This procedure is the same for both direct and reverse action controllers. Tighten the knurled screw.

---

#### NOTE

The RAISE LEVEL dial does not reflect actual fluid level in the tank or fluid level position on the displacer.

---

### Proportional Band Adjustment

Proportional band adjustment is made to change the amount of displacement force change required to obtain full output pressure change, by determining the percentage of pressure fed back to the proportional bellows. The adjustment is performed by opening the controller cover and turning the percent proportional band knob (just below the RAISE LEVEL dial).

### Reset Adjustment

To adjust reset action (Figure 9) turn the knob clockwise to decrease reset time (the minutes per repeat). Turn the knob counterclockwise to increase the minutes per repeat. Increasing the minutes per repeat provides a slower reset action.

Figure 9. Controller Adjustments

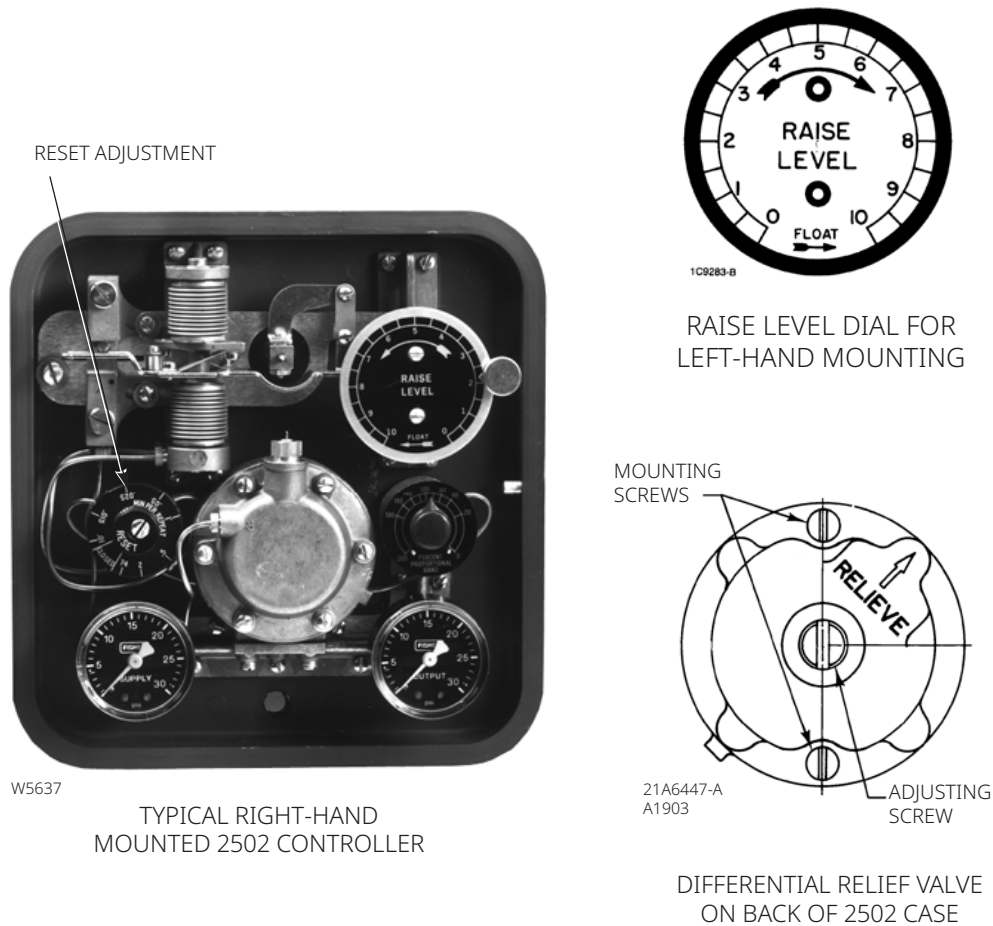

The reset rate adjustment dial is calibrated in minutes per repeat. By definition, this is the time in minutes required for the reset action to produce a correction which is equal to the correction produced by proportional control action. This is, in effect, the time in minutes required for the controller to increase (or decrease) its output pressure by an amount equal to a proportional increase (or decrease) caused by a change in control conditions.

### Differential Relief Adjustment

The differential relief valve protrudes from the back of the controller case on a construction with an F in the type number. Although normally factory-set to relieve when the differential between the proportional and reset bellows reaches 5 psi, the differential may be reduced down to 2 psi by turning the adjustment screw clockwise or increased up to 7 psi by turning the screw counterclockwise. The minimum differential setting will yield the minimum set point overshoot during startup.

Depending on the characteristics of the process, the relief valve can be positioned so that the arrow cast on the case points either to the letters RE (reset) or to the letter P (proportional) on the back of the manifold. To reposition the arrow, see Figure 9. Remove the mounting screws. Reposition the differential relief valve to RE or P and reinstall the mounting screws.

## Section 4: Calibration

### 4.1 Precalibration Requirements

---

**NOTE**

Calibration of a unit with a displacer designed for interface or density control must be conducted with the displacer completely submerged in a liquid of the specific gravity for which the unit was designed.

---

To calibrate a controller, it is necessary to place the device into operation. This may be done on the vessel with the actual service liquid. It may also be done in the shop, but other means of obtaining a displacement force change must be provided. It must be done in the shop if the process variable is not available for calibration or if the process cannot be varied for calibration. There are two methods of adapting the calibration procedure to shop calibration: wet and dry.

#### Wet Calibration

Remove the entire controller and sensor assembly from the vessel. For caged sensors, pour the liquid into the cage. For cageless sensors, suspend the displacer to an appropriate depth in a liquid having a specific gravity equal to that of the process liquid.

If necessary, use water for wet calibration in the shop. However, this procedure requires compensation for the difference between the specific gravity of the water and that of the process liquids. For example, assume that the process liquid has a specific gravity of 0.7 and that wet calibration with water (specific gravity of 1.0) is desired. To simulate a process level of 50 percent of the input span, a water level of 35 percent is required ( $0.7/1.0 \times 50 \text{ percent} = 35 \text{ percent}$ ).

#### Dry Calibration

Remove the controller and torque tube arm, as a single unit, from the cage or vessel. Then, wherever the standard calibration instructions in this manual require a specific process variable for input to the sensor, simulate that variable by suspending the proper weight (such as a can of sand) from the end of the displacer rod. Complete the following Controller and Torque Tube Arm Disassembly and Determining Suspended Weight for Calibration sections before proceeding to the Calibration Procedure.

## Controller and Torque Tube Arm Disassembly

### **⚠ WARNING**

**To avoid personal injury from contact with the process liquid, lower the vessel level below the sensor torque tube arm, or shut off the cage equalizing valves and drain the cage before proceeding. For closed vessels, release any pressure that may be in the vessel before removing the sensor assembly.**

When removing the displacer from the displacer rod or removing the controller and torque tube arm from the cage or vessel, refer to the appropriate sensor instruction manual for assistance. The method of removing the displacer or torque tube arm and attached controller will vary with the type of sensor.

For a caged sensor with top equalizing connection, it may be appropriate to remove the entire cage from the vessel before disassembling.

### **NOTICE**

**If the displacer is to be disconnected from the displacer rod before the sensor assembly is removed from the cage or vessel, provide a means of supporting the displacer to prevent it from dropping and suffering damage. The spuds or stem end pieces on all displacers have holes suitable for inserting rods or other supports.**

**Additionally, a threaded rod may be installed into the 1/4-in. 28 UNF threaded hole in the displacer spud or stem end piece of top-mounted cageless and all caged sensors. For some top-mounted sensors with long displacers, it may also be possible to remove the sensor through the access hole in the sensor head.**

**For the 249BP sensor with the travel stop, the stem end piece pins will secure the displacer as long as the travel stop plate is installed and the sensor head is in position.**

## Determining Suspended Weight for Calibration

### **NOTICE**

**To avoid overloading a torque tube sized for interface or density applications under dry conditions, consult your [Emerson sales office](#) for the maximum allowable substitute weight  $W_s$  that can be used with your particular construction.**

To determine the total weight that must be suspended from the displacer rod to simulate a certain condition of liquid level or specific gravity, solve the following equation:

$$W_s = W_d - [(0.0361) (V) (SP GR)]$$

where:

$W_s$  = Total suspended weight in pounds (should never be less than 0.5 pounds). For a unit with a horizontal displacer, make sure the center of gravity of the substitute weight is where it would be on the actual displacer.

**NOTE**

For liquid level control only, simulate the lower range limit of the input span by suspending the displacer from the displacer rod. For other values of input span, remove the displacer and suspend the appropriate weight as determined in the equation above.

$W_d$  = Weight of the displacer, in pounds (determine by weighing displacer)

0.0361 = Weight of one cubic inch of water (specific gravity = 1.0), in pounds

$V$  = Volume of the displacer in cubic inches, that would be submerged at the level required by the calibration procedure. Or,

$V = \pi/4$  (displacer diameter)<sup>2</sup> (length of displacer submerged)

SP GR = Specific gravity of the process liquid at operating temperature.

For interface level measurement, the equation becomes:

$$W_s = W_d - [(0.0361) (V_1) (SP GR_1) + (0.0361) (V_h) (SP GR_h)]$$

where:

$V_1$  = Volume of the displacer submerged by the lighter liquid, in cubic inches.

Or,

$V = \pi/4$  (displacer diameter)<sup>2</sup> (length of the displacer submerged)

SP GR<sub>1</sub> = Specific gravity of the lighter liquid at operating temperature

$V_h$  = Volume of the displacer submerged by the heavier liquid, in cubic inches.

Or,

$V = \pi/4$  (displacer diameter)<sup>2</sup> (length of the displacer submerged)

SP GR<sub>h</sub> = Specific gravity of the heavier liquid at operating temperature.

## 4.2 Calibration Procedure

### WARNING

**The following calibration procedure requires taking the controller out of service. To avoid personal injury and property damage caused by an uncontrolled process, provide some temporary means of control for the process before taking the controller out of service.**

Figure 9 shows adjustment locations for the following steps, except as otherwise indicated. When calibrating, open loop conditions must exist. One way to obtain an open loop is to place the final control element into manual control or bypass it. If there is no provision for manual control, shut down the process. It is recommended that a test pressure gauge be installed in the controller output line for subsequent calibration steps.

Several steps in these calibration procedures require setting the process variable at its minimum and maximum limits according to Table 2. Reverse-acting controllers produce the opposite response.

**Table 2. Displacer and Torque Tube Materials**

Application	Minimum Limit	Maximum Limit
Liquid level	Displacer must be completely out of liquid	Displacer must be completely submerged in liquid
Interface	Displacer must be completely submerged in the upper of two process liquids	Displacer must be completely submerged in the lower of two process liquids
Density	Displacer must be completely submerged in liquid having highest specific gravity expected	Displacer must be completely submerged in liquid having the lowest specific gravity expected

1. Connect a supply pressure source to the controller and provide a supply pressure suitable for the sensing element range: 1.4 bar / 20 psig for a 0.2 to 1.0 bar / 3 to 15 psig output pressure range or 2.4 bar / 35 psig for a 0.4 to 2.0 bar / 6 to 30 psig output pressure range.
2. Rotate the reset knob to 0.01 minutes per repeat.
3. Rotate the proportional band knob to zero.
4. Set the liquid at the minimum limit (dry displacer).
5. Turn the RAISE LEVEL knob to zero.
6. Adjust the nozzle until output pressure is between 0 and 0.2 bar for a 0.2 to 1.0 bar signal range / 0 and 3 psig for a 3 to 15 psig signal range or 0 and 0.4 bar for a 0.4 to 2.0 bar signal range / 0 and 6 psig for a 6 to 30 psig signal range.
7. Set the liquid at the maximum limit (covered displacer).
8. Turn the RAISE LEVEL knob until the output pressure is 1.0 bar for a 0.2 to 1.0 bar signal range / 15 psig for a 3 to 15 psig signal range or 2.0 bar for a 0.4 to 2.0 bar signal range / 30 psig for a 6 to 30 psig signal range.

9. The controller is within its calibration accuracy if the RAISE LEVEL knob is between the 9.0 and 10.0 positions.
10. If the controller is out of calibration, adjust the calibration adjuster as follows:

---

**NOTE**

Loosen the two calibration adjuster screws (key 45, Figure 14), and slide the calibration adjuster (key 100, Figure 14) in the desired direction

---

- a. If output is below 1.0 bar for a 0.2 to 1.0 bar signal range / 15 psig for a 3 to 15 psig signal range or 2.0 bar for a 0.4 to 2.0 bar signal range / 30 psig for a 6 to 30 psig signal range, move the adjuster a small distance away from the pivot to increase span (movement should be away from the torque tube). Then repeat steps 4 through 9.
- b. If output is above 1.0 bar for a 0.2 to 1.0 bar signal range / 15 psig for a 3 to 15 psig signal range or 2.0 bar for a 0.4 to 2.0 bar signal range / 30 psig for a 6 to 30 psig signal range, move the adjuster a small distance toward the pivot to decrease span (movement should be toward the torque tube). Then repeat steps 4 through 9.

---

**NOTE**

If the controller cannot be calibrated, look for other problems as described in the Troubleshooting section, such as a nonperpendicular flapper-nozzle condition, leaky connections, or a binding displacer rod. If none of these troubles is apparent, the displacer or torque tube may be sized for a different set of service conditions. Ensure that the displacer is sized correctly for the application.

---

## Section 5: Startup

Adjustment locations are shown in Figure 9.

1. Set the RAISE LEVEL control to the desired control point as determined in Prestartup Checks step 4.
2. Set the percent proportional band control to 200.
3. Set the reset control to .05 minutes per repeat.
4. Slowly open the downstream and upstream manual control valves in the pipeline and close the manual bypass valve if one is used.
5. With the controller set at the desired control point, narrow the proportional band until a cycling condition exists. Then broaden the proportional band slightly until stable control is obtained.
6. Adjust the reset control to obtain the highest reset setting without introducing cycling.
7. To ensure that the optimum proportional band and reset settings have been obtained, momentarily create a load upset. If cycling occurs, broaden the proportional band slightly and repeat the load upset until stability is attained. In general, the narrowest proportional band and the highest reset setting that will not produce cycling will provide the best control.

## Section 6: Principle of Operation

All 2502 controllers use the same basic pressure-balanced relay with a yoked double-diaphragm assembly (Figure 10). This relay is connected so that supply pressure is fed to the inlet side of the relay valve and to the fixed restriction. From this restriction, the air pressure goes into the relay chamber on the side of the large diaphragm, and to the nozzle. As long as there is no pressure change on either diaphragm, the relay valve remains in equilibrium with both the inlet and exhaust ends closed.

The area ratio of the large diaphragm to the small diaphragm is 3 to 1. A 0.8 bar / 12 psig pressure change on the small diaphragm need only be balanced by a 0.3 bar / 4 psig change on the large diaphragm.

A change in liquid level, interface level, or density changes the buoyant force exerted on the sensor displacer, which in turn imparts a rotary motion through the torque tube shaft. The rotary motion is applied to the controller, which uses a nozzle, bellows, and pneumatic relay to convert the rotary motion to a standard pneumatic output signal. The output signal is sent to a final control element. In conjunction with this control element, 2502-249 controller-sensors are capable of bringing the controlled variable back to a specific control point all the time.

The following descriptions show how the relay works in conjunction with the standard proportional-plus-reset controller, and how the differential relief valve construction works.

### 6.1 2502 Controller

As long as inflow and outflow of the vessel are equal, the beam and flapper remain motionless and allow supply pressure to bleed through the nozzle as fast as it enters the relay through the fixed restriction. A level or density change either raises or lowers the displacer and pivots the beam and flapper with respect to the nozzle.

---

#### NOTE

The relay valve is double sided to control supply on one end and exhaust on the other.

---

An increase in level or density with direct action, or a decrease with reverse action, moves the beam and flapper closer to the nozzle and restricts the escape of supply pressure. This builds up the loading differential on the side of the large diaphragm and opens the relay valve to supply pressure inflow.

On the other hand, a decrease in level or density with direct action, or an increase with reverse action, moves the beam and flapper away from the nozzle and permits supply pressure to bleed through the nozzle faster than it can enter through the fixed restriction. This builds up the loading differential on the side of the small diaphragm, and opens the relay valve to exhaust loading pressure.

The three-way proportional valve can be opened and adjusted to allow some or all of the output pressure change to feed back to the proportional bellows in order to change the proportional band of the controller. This pushes the beam and flapper opposite the way it is being pivoted by the torque tube shaft, counteracting the pressure change in the nozzle and again stabilizing the relay diaphragm pressure differential. The relay valve shuts off and maintains a new output pressure according to the change in sensed displacer position.



Figure 10. Direct-Acting Right-Hand-Mounted Fisher 2502-249 Controller

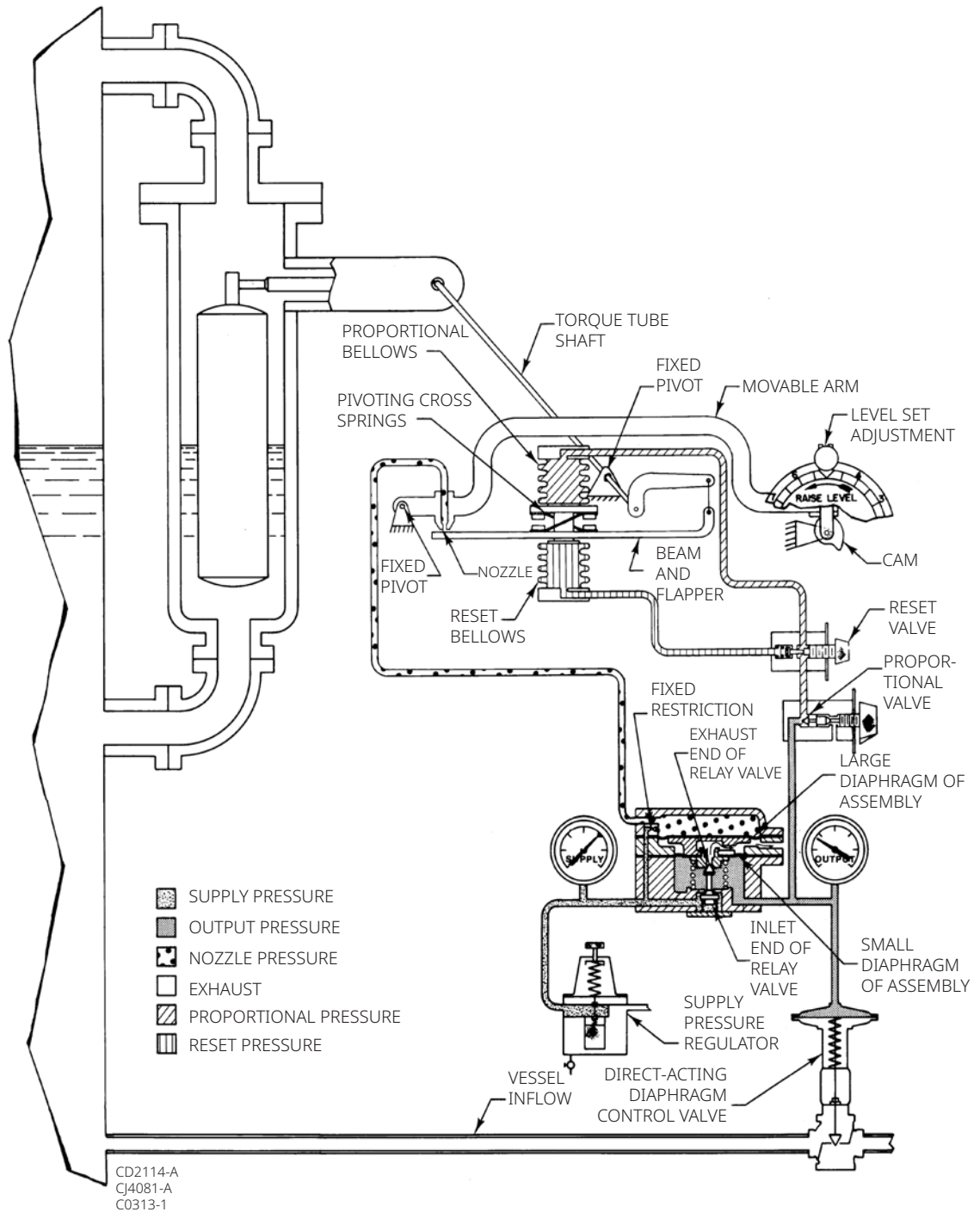

A wide-open proportional valve permits feedback of all the output change and produces 100 percent proportional response. Closing of this valve produces smaller proportional responses, since part of the output change is vented through the valve exhaust and only the remainder is available to reposition the bellows.

The reset valve can be adjusted to channel some or all of the proportional pressure into a reset bellows that opposes proportional bellows action. This automatically dampens the effect of any proportional overcorrection by a set amount per time interval, as long as there is a deviation from the control point.

Figure 10 illustrates these principles at work in a direct-acting right-hand-mounted construction controlling liquid inflow to a vessel, by means of a direct-acting diaphragm-actuated control valve. Nozzle positions and bellows connections would be reversed for direct action with left-hand mounting or reverse action with right-hand mounting.

## 6.2 2502F Controller with Differential Relief Valve

This construction (Figure 11) has a differential relief valve used to prevent proportional pressure from exceeding reset pressure by more than a set value, a feature useful for intermittent control applications. Proportional valve output registers in the outer chamber of the relief valve as well as in the proportional bellows.

Figure 11. Fisher 2502F Controller with Differential Relief Valve

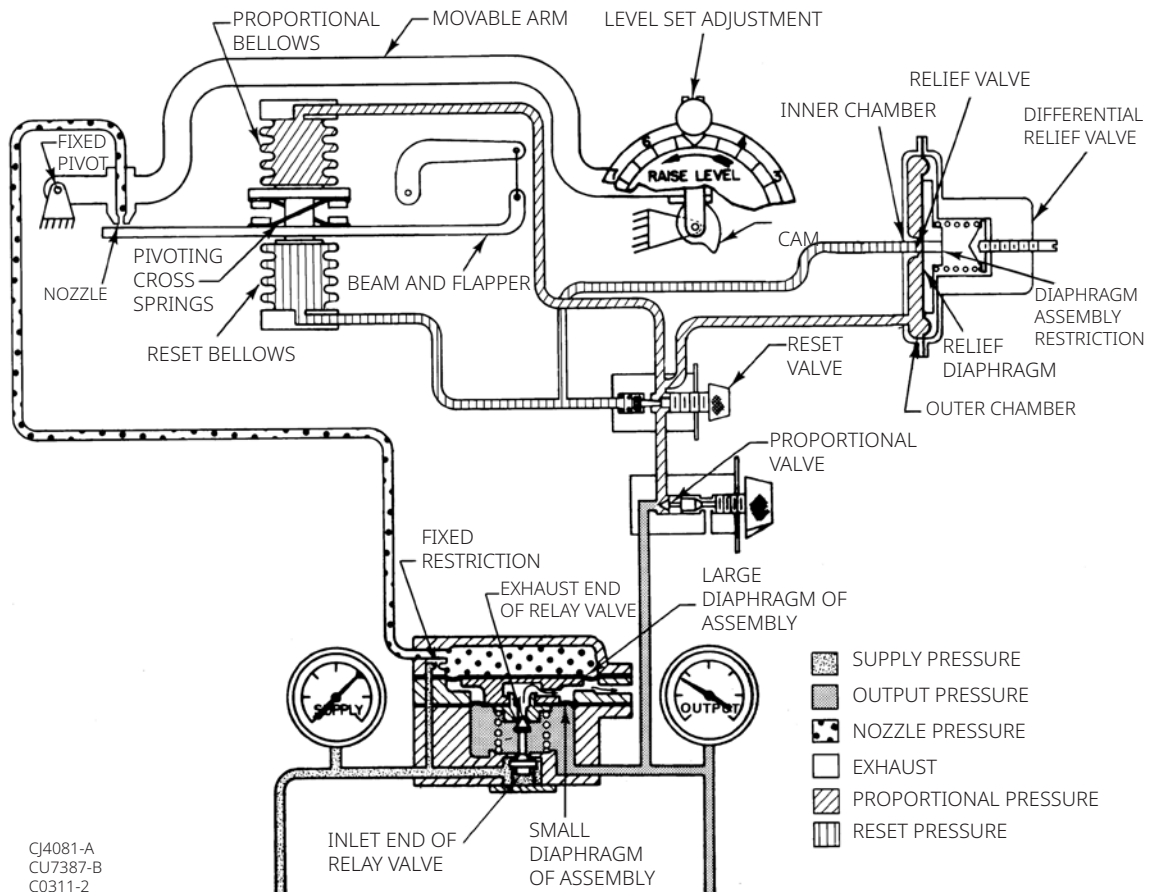

A sudden increase in the output pressure will cause a rapid pressure increase in the proportional bellows and in the outer relief valve chamber. If the outer chamber pressure exceeds that in the inner relief valve chamber by the amount of the relief pressure setting, the relief diaphragm will move off the orifice in the relief valve, and the pressure in the outer chamber will bleed into the reset system. This action provides quick relief of excessive proportional pressure and reduces the time required by the system to return to the control point.

## Section 7: Maintenance

2502 controllers are used in combination with 249 sensors.

### **WARNING**

**Always wear protective clothing, gloves, and eyewear when performing any maintenance operations to avoid personal injury.**

**Personal injury or property damage due to sudden release of pressure, contact with hazardous liquid, fire, or explosion can be caused by puncturing, heating, or repairing a displacer that is retaining process pressure or liquid. This danger may not be readily apparent when disassembling the sensor or removing the displacer. Before disassembling the sensor or removing the displacer, observe the more specific warning provided in the sensor instruction manual.**

**When disconnecting any of the pneumatic connections, natural gas, if used as the supply medium, will seep from the unit and any connected equipment into the surrounding atmosphere. Personal injury or property damage may result from fire or explosion if natural gas is used as the supply medium and preventive measures are not taken.**

**Preventive measures may include, but are not limited to, one or more of the following:**

- remote venting of the unit,
- re-evaluating the hazardous area classification,
- the removal of any ignition sources, and
- ensuring adequate ventilation.

**For information on remote venting of this controller refer to Section 2.8 Vent Assembly.**

**Check with your process or safety engineer for any additional measures that must be taken to protect against process media.**

## 7.1 Troubleshooting

When troubleshooting, open loop conditions must exist unless otherwise stated. When monitoring the process variable, use the most accurate level indicating device readily available. The output signal measuring device should have a corresponding accuracy.

Table 3 lists some common operating faults, their probable causes, and corrective action.

**Table 3. Troubleshooting Chart for Fisher 2502 Controller**

Fault	Possible Cause	Check	Correction
1. Process wanders or cycles around set point	Proportional band or specific gravity adjustment incorrect or improperly tuned control loop.	Ensure the prestartup procedures are completed correctly. Tune control loop.	If stable control cannot be attained and all other elements are functionally correct, examine other possible causes related to the controller.
	Supply pressure varying or incorrect supply pressure setting.	Use input pressure gauge to monitor stability. Make sure regulator IN supply pressure is within limits.	Apply correct supply pressure. It is recommended to use one regulator per instrument.
	Sensor not plumb and is in contact with sidewall or leak in displacer.	Check cage vessel and stillwell installation, or for leaking displacer.	Make sure the displacer and displacer rod hangs freely. Make sure linkage is tight. Replace displacer if leaking.
	Relay malfunction	Check for relay malfunction by using the testing relay deadband procedure	Depress plunger to clean out the fixed restriction. Replace or repair relay using the procedure in Section 7: Maintenance.
2. Controller controlling off set point or switching point	Supply pressure not set correctly	Make sure regulator supply pressure is set correctly. Make sure regulator IN supply pressure is within limits.	Reset the supply regulator pressure. If the condition occurs again, rebuild or replace regulator. Provide a regulator input pressure within regulator limits.
	Leak in the controller loop	Use soap and water to check for internal and external leaks.	Replace or repair leaking parts as necessary.
	Leaking displacer	Ensure the displacer is not filling with process fluid.	Refer to sensor maintenance procedures in the appropriate sensor instruction manual.
	Flapper adjustment	Ensure the flapper is not loose on the torque tube shaft and is centered on the nozzle.	Replace or tighten flapper assembly as necessary and/or center flapper on nozzle.
	Process variable changed	Ensure the process variable has not changed from original calibration settings or, displacer not design specific gravity of process.	Change process variable back to original specification or recalibrate. If necessary, provide replacement displacer of correct size and recalibrate.

- continued -

**Table 3. Troubleshooting Chart for Fisher 2502 Controller (continued)**

Fault	Possible Cause	Check	Correction
3. Controller cannot attain full output range	Supply pressure not set correctly	Make sure supply pressure is set correctly. Make sure regulator IN supply pressure is within limits.	Reset the regulator pressure. If problem reoccurs, replace or rebuild the regulator. Ensure regulator IN supply pressure is within limits at all operating levels.
	Flapper adjustment	Ensure the flapper is not loose on the torque tube shaft and is centered on the nozzle.	Replace or tighten flapper assembly as necessary and/or center flapper on nozzle.
	Process variable changed	Ensure the process variable has not changed from original calibration settings or, from displacer design specific gravity.	Change process variable back to original specification or recalibrate. If necessary, provide replacement displacer of correct size and recalibrate.
	Relay malfunction	Check for relay malfunction by using the testing relay deadband procedure.	Depress plunger to clean out the fixed restriction. Replace relay using the procedure in Section 7: Maintenance.
	Leak in the controller loop	Use soap and water to check for internal and external leaks.	Replace or repair leaking parts as necessary.
4. Controller remains at full or zero output pressure	Supply or output pressure gauge malfunction	Ensure the pressure gauges are registering correctly.	Replace pressure gauges. Use corrective action given in Fault 3 immediately above.
	Flapper adjustment	Ensure the flapper is not loose on the torque tube shaft. Ensure the flapper is centered on the nozzle.	Replace or tighten flapper assembly as necessary and/or center flapper on nozzle.

## 7.2 Removing Controller from Sensor

### **WARNING**

**To avoid personal injury in the following steps, turn off the supply pressure and carefully release any pressure trapped in the controller before breaking any pressure connection. Provide a bypass for the control device if continuous operation is required during maintenance.**

Refer to Figure 14 for key number locations, unless otherwise indicated.

1. Disconnect the supply and output pressure tubing from the controller.
2. Loosen the hex nut (key 40) that secures the operating arm base or pointer assembly (key 68 or 51) to the torque tube rotary shaft. Do not lose the two link bearings (key 87, not shown).

**NOTICE**

If the hex nut has not been loosened according to step 2, attempting to remove the controller from the sensor may bend the rotary shaft or operating arm and linkage. Be careful that the back of the controller case or the heat insulator does not drop down and bend the rotary shaft or shaft extension.

3. Remove any insulating tape from the joint between the controller case and the torque tube arm. Remove the four cap screws (key 39, Figure 12) that hold the controller or heat insulator to the torque tube arm. Pull the case straight out from the torque tube arm, easing it over the shaft coupling (key 36, Figure 12) if one is installed.

**Figure 12. Heat Insulator Shown Installed on Fisher 249 Sensor**

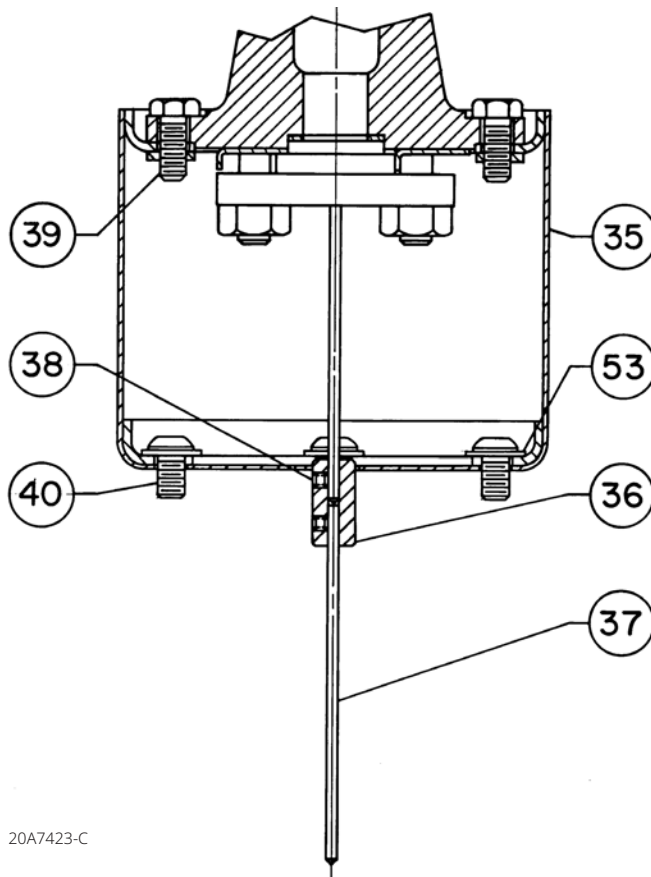

20A7423-C

4. If the controller has a heat insulator, remove the button head cap screws (key 40). Remove four washers (key 53) and the insulator assembly (key 35).

## 7.3 Changing Mounting Method

### **⚠ WARNING**

**To avoid personal injury from contact with the process liquid, lower the vessel level below the torque-tube arm before proceeding. For closed vessels, release any pressure that may be above the liquid. Also, be careful to avoid overloading a thin-wall torque tube and/or oversized displacer.**

Refer to Figure 14 for key number locations.

1. Remove the controller as described previously.
2. A controller is attached to the sensor in one or the other of the mounting positions shown in Figure 4. Right hand mount is with the case to the right of the displacer when looking at the front of the case. Left hand mount is with the case to the left of the displacer. For a 249 sensor, remove the torque tube arm from the sensor or vessel and reinstall the torque tube arm in the opposite position according to the appropriate instruction manual.
3. Check the desired control action to determine if it is also necessary to reverse the controller action. The nozzle block and bellows tubing should be arranged in the proper position as shown in Figure 13.
4. Remove the RAISE LEVEL dial, turn it over, and install it in the desired position. The arrow on it under the word FLOAT should point toward the displacer.
5. Install the controller according to the next section.

## 7.4 Installing Controller on Sensor

### **NOTE**

If the installation is in a location that is not readily accessible and shop calibration is required, remove the torque tube arm from the cage or vessel before mating the controller to the sensor. Install the controller on the torque tube arm in the shop; then calibrate and return the controller and torque tube arm assembly to the installation.

**Perform step 1 only if adding a heat insulator to a unit that does not have one. Key numbers in this step are shown in Figure 12, unless otherwise indicated.**

1. To install the heat insulator, secure the shaft extension (key 37) to the torque tube assembly rotary shaft with the shaft coupling (key 36). Tighten both set screws (key 38), with the coupling centered as shown in the figure. Then mount the insulator assembly (key 35) on the controller case with four washers (key 53) and button-head cap screws (key 40). Tighten the screws.

## NOTICE

**In the following step, avoid bending the torque tube rotary shaft of the torque tube assembly. Bending or side loading of this shaft could cause erroneous readings. Additionally, make sure the ball bearing assembly (key 12, Figure 14) is removed from the case (key 1, Figure 14) to provide clearance when installing the case on the sensor.**

2. Remove the bearing assembly (key 12) from the case (key 1).
3. Carefully slide the controller case straight in, guiding the bearing assembly (key 12), operating arm base or pointer assembly (key 68 or 51, Figure 14) over the rotary shaft and easing an attached heat insulator over the shaft coupling (key 36) if necessary. Secure the case or insulator to the torque tube arm with the four cap screws (key 39).

## NOTE

If a heat insulator is used, do not insulate its exterior.

4. On a unit without a heat insulator, tape the joint between the case and torque tube arm to minimize the entrance of atmospheric moisture around the torque tube rotary shaft.
5. Install and tighten the bearing assembly (key 12, Figure 14) in the case (key 1, Figure 14). Secure the operating arm base or pointer assembly to the rotary shaft by tightening the hex nut (key 40, Figure 14). Connect the supply and output pressure tubing and perform the calibration procedure.

## 7.5 Changing Proportional, Reset, or Differential Relief Valve

1. Remove the proportional band valve assembly (key 36, Figure 14) by unscrewing it from the relay base (key 23, Figure 14). Install the desired replacement assembly, or a 1/8 NPT pipe plug into the proportional band tapping if testing relay dead band.
2. To change the reset restriction valve assembly (key 91), remove the two mounting screws (key 182) located on the back side of case. Install the replacement valve assembly, and reconnect the tubing connections.
3. Remove the differential relief valve assembly (key 186, Figure 14) by removing the two mounting screws (Figure 9) that anchor the valve to the manifold (key 184, Figure 14). Install the valve with the arrow pointing to the same letter(s) as before removal, unless it is desired to change the relief action.



## 7.6 Testing Relay Dead Band

1. Replace the proportional band adjustment assembly with a 1/8 NPT pipe plug according to the Changing Proportional, Reset, or Differential Relief Valve section.
2. Turn on the supply pressure and set it to 1.4 or 2.4 bar / 20 or 35 psig.
3. By changing the process variable and adjusting the RAISE LEVEL control, set the output pressure to 1.0 or 2.0 bar / 15 or 30 psig. While monitoring the output pressure, slowly change the process until an output pressure change can just be detected, and record the value of the process variable at the detection point.
4. Change the process variable in the opposite direction until another output pressure change can be detected, and again record the value of the process variable. If the difference between the two recorded values (the dead band) is more than 0.2 percent of the maximum displacer length, the relay will have to be replaced or repaired according to the Changing Relay procedure.
5. Turn off the supply pressure, remove the pipe plug, and install the proportional band adjustment assembly.

## 7.7 Changing Relay

The relay may be removed for cleaning or replacement, and must be taken off to remove the lower bellows.

1. Disconnect the tubing (key 11, Figure 14) from the relay.
2. Remove both mounting screws, the relay, and the relay gasket (keys 43, 34, and 22, Figure 14).
3. Install a new gasket, the replacement relay if necessary, and both mounting screws. Reconnect the tubing.

## 7.8 Replacing Bellows

Key numbers are shown in Figure 14.

1. To gain access to the lower bellows, remove the relay according to Section 7.7: Changing Relay.
2. Remove the upper and lower bellows frame screws (key 96) that hold both bellows assemblies to the bellows frame. Unscrew each bellows from the spacer (key 98), being careful not to lose the O-ring (key 57, not shown) from the spacer end of the bellows.
3. Inspect each bellows and O-ring and replace if necessary, using an unpainted bellows for a 0.2 to 1.0 bar / 3 to 15 psig range and a red bellows for a 0.4 to 2.0 bar / 6 to 30 psig range. Be sure to install the O-ring at the spacer end of the bellows.
4. Install each bellows by screwing it down over the stud (key 97, not shown) protruding from each end of the spacer. Secure with a bellows frame screw, and install the relay according to the Changing Relay procedure.
5. Perform the Calibration Procedure and any other necessary part of the calibration sequence.

## 7.9 Reversing Action

### NOTE

The following procedure will be necessary to restore previous action if the mounting method has been changed. Key numbers are shown in Figure 14.

1. Remove two screws (keys 63 and 64), two seal rings (key 55), and the nozzle block (key 101). Check seal ring condition and replace rings as necessary.
2. Install the nozzle block, seal rings, and screws on the opposite side of the beam as shown in Figure 13. Disconnect the proportional band tubing (key 76) and one of the two pieces of reset tubing (key 75) from the bellows frame (key 94) and reconnect them in the proper orientation as shown in Figure 13.

**Figure 13. Nozzle, Flapper, and Tubing Arrangements for Various Actions and Mountings**

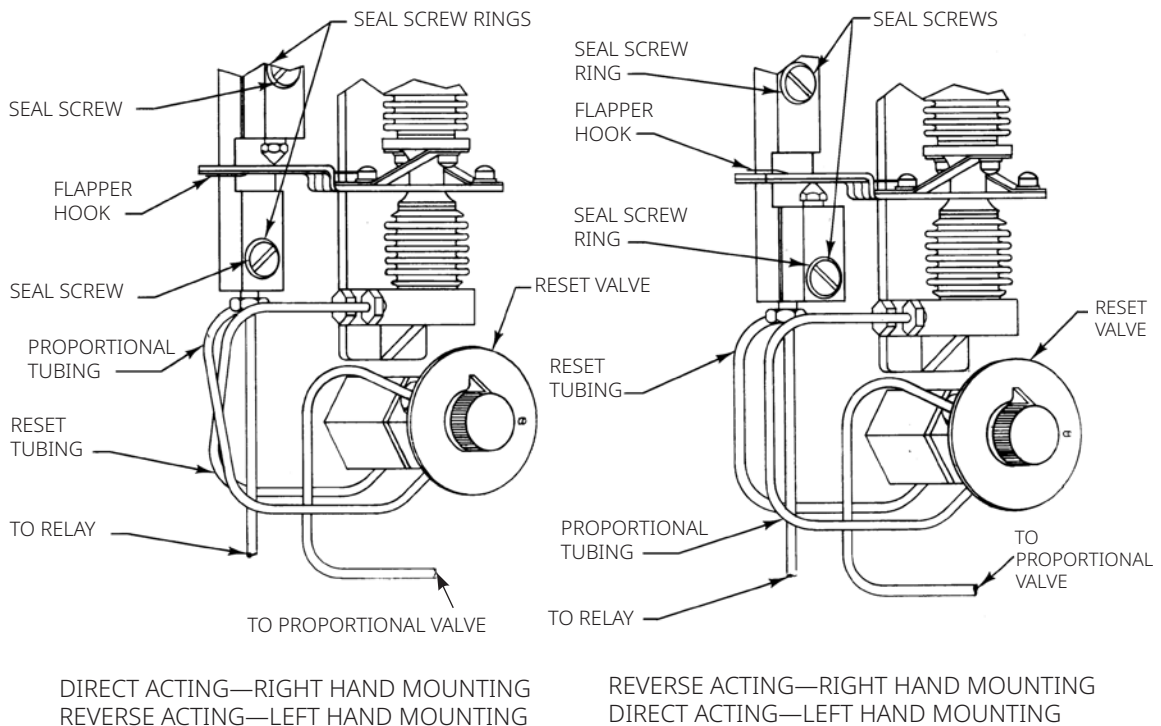

---

**NOTE**

Beam overtravel can jam the flapper against the nozzle if the following step is not performed.

---

3. Remove the flapper screw (key 93), lockwasher (key 84), and flapper (key 60). Invert the flapper so that the flapper hook is on the opposite side of the beam from the nozzle (key 58), and secure with the lockwasher and screw.
4. Perform the Calibration Procedure and any other necessary part of the calibration sequence.

## Section 8: Parts

### 8.1 Parts Ordering

Whenever corresponding with your [Emerson sales office](#) about this equipment, always mention the controller type number and the serial number found on the unit nameplate (Figure 14).

#### **WARNING**

**Use only genuine Fisher replacement parts. Components that are not supplied by Emerson should not, under any circumstances, be used in any Fisher instrument. Use of components not supplied by Emerson may void your warranty, might adversely affect the performance of the instrument, and could cause personal injury and property damage.**

### 8.2 Parts Kits

Description	Part Number
Controller Parts Kit, contains keys 12, 15, 21, 24, 38, 55, 57, 58, 60, 62, 63, 64, 77, 79, 84, 86, 87, 93, 101, and 187 Standard temperature High temperature	R2502X00L52 R2502X00H52
Relay Replacement Kit, contains keys 22, 43, and the relay assembly Standard temperature High temperature	RRELAYX0L22 RRELAYX0H22
Heat Insulator Parts Kit, contains keys 35, 36, 37, 38, 39, 40, and 53	R2500XH0012
2500 Controller Cover Gasket Kit, contains qty. 5 cover gaskets, key 21	R2500CVR012

## 8.3 Parts List

### Controller Common Parts (Figure 14)

**NOTE**

Contact your [Emerson sales office](#) for Part Ordering information.

Key	Description	Key	Description
1	Pilot Case back 2502 2502F	35	Level Adjustment Assembly
		36	Proportional Valve Assembly
		37	Pressure Regulator (67CF)
2	Pilot Case Cover	38A*	Filter Gasket (not shown) Standard temperature High temperature
3	Door Handle		
4	Door Handle Shaft (not shown)		
5	Machine Screw	38B	Spacer (not shown)
6	Washer Spring	38C*	O-ring (not shown) Standard temperature High temperature
7	Door hook		
8	Elastic Stop Nut		
9	Drive Pin (2 req'd)	39	Cap Screw (not shown) (2 req'd)
11	Relay Tubing	40	Hex Nut
12*	Ball Bearing Assembly	42	Machine Screw (8 req'd)
13	Retaining Ring (2 req'd)	43	Machine Screw (2 req'd)
14*	Gauge Glass (2 req'd)	44	Machine Screw pl (4 req'd)
15*	Gauge Glass Gasket (2 req'd)	45	Machine Screw (2 req'd)
19*	Pressure gauge (2 req'd) Triple Scale 0 to 30 psig/0 to 0.2 MPa/0 to 2 bar 0 to 60 psig/0 to 0.4 MPa/0 to 4 bar Dual scale gauge (2 req'd) 0 to 30 psig / 0 to 2 kg/cm <sup>2</sup> 0 to 60 psig / 0 to 4 kg/cm <sup>2</sup>	47	Spring (not shown)
		49	Machine Screw (13 req'd)
		50	Screen
21*	Cover Gasket	55*	O-Ring (3 req'd) Standard High-temperature
22*	Relay Gasket Standard temperature High temperature		
23	Relay Base	57	O-Ring (not shown) Standard High-temperature
24*	Relay Base Gasket (not shown) Standard temperature High temperature	58*	Nozzle
		59	Beam
29*	Drive-lok Pin	60	Flapper
31	Shaft Clamp Screw	61	Flapper Base
34	Pilot Relay Standard temperature High temperature	62*	Connecting Link
		63	Sealing Screw
* Recommended spare parts			

Figure 14. Fisher 2500 Controller Constructions

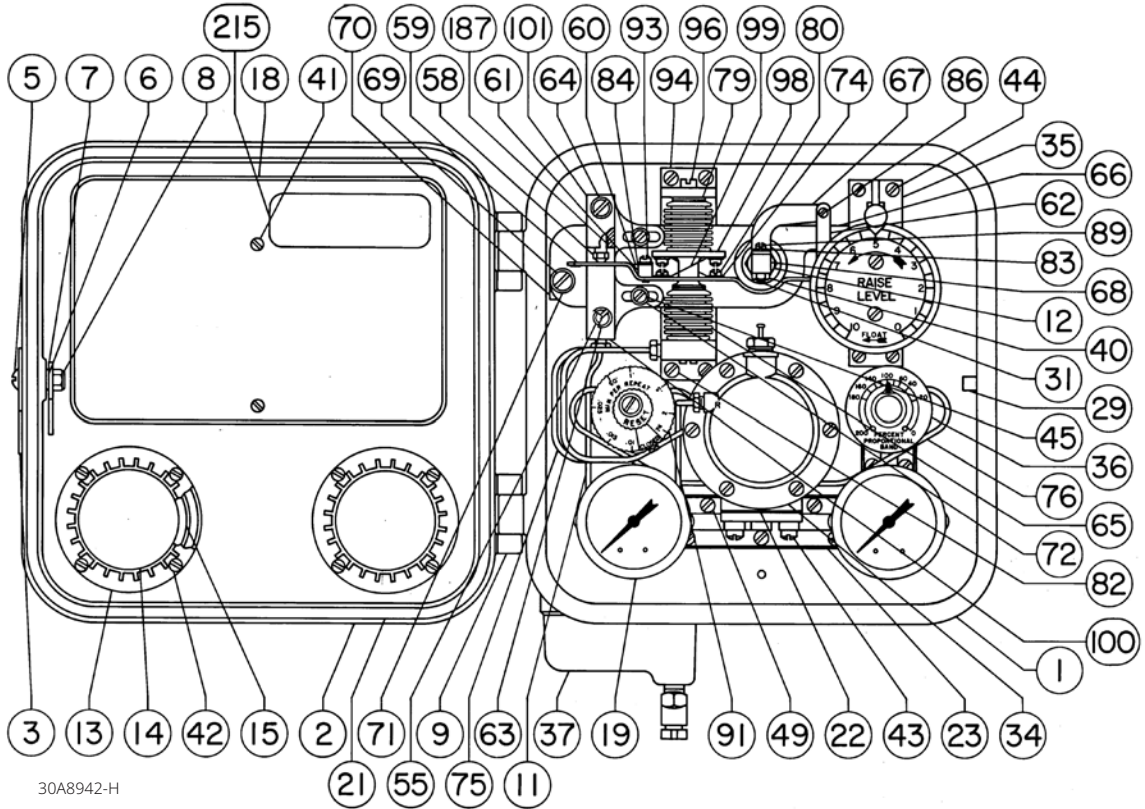

TYPICAL CONTROLLER

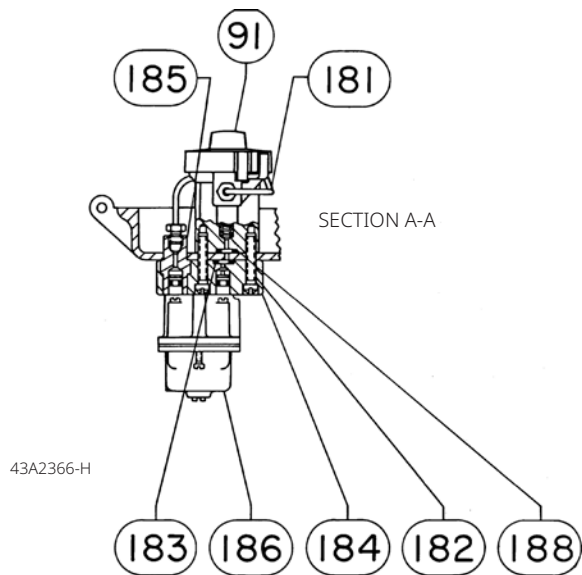

DETAIL OF RELIEF VALVE ASSEMBLY ON 2502F CONTROLLER



Key	Description	Key	Description		
64	Screw	87*	Link Bearing (not shown) (2 req'd)		
65*	Bellows Assembly (2 req'd) 0.2 to 1.0 bar / 3 to 15 psig 0.4 to 2.0 bar / 6 to 30 psig	88	Machine Screw (not shown) (4 req'd)		
		89	Machine Screw (2 req'd)		
66	Level Set Arm	91	RESET Restriction Valve Ass'y 2502 2502F		
67	Operating Arm				
68	Operating Arm Base, 2502 and 2502F	93	Machine Screw		
69	Level Set Pivot Pin	94	Bellows Frame		
70	Pivot Base	95	Bellows Frame Base (not shown)		
71*	Spring Washer	96	Bellows Screw (2 req'd)		
72	Washer, 2502 (2 req'd)	97	Bellows Stud (not shown)		
		98	Spacer		
		99	Cross Spring (2 req'd)		
74	Washer (6 req'd)	100	Calibration Adjuster		
75	Reset Tubing Ass'y (2 req'd)	101	Reversing Block		
76	Proportional Band Tubing Assembly	180	Pipe Nipple (not shown), 2502F		
77*	Bellows Frame Gasket (not shown) Standard High Temperature	181	Relief Tubing Ass'y, 2502F		
		182	Machine Screw (2 req'd) 2502 (not shown)		
78	Spacer (not shown)	183*	O-Ring (2 req'd), 2502F		
79*	Bellows Gasket (2 req'd) Standard High Temperature			184	Manifold, 2502
				185	Manifold Nipple, 2502F
80	Machine Screw (4 req'd)	186	Differential Relief Valve Ass'y, 2502F Standard High Temperature		
81	Machine Screw (not shown) (2 req'd)				
82	Machine Screw (4 req'd)				
83	Lock Washer (2 req'd)	187	Sleeve		
84	Lock Washer	188*	O-Ring, 2502F		
85	Cap Screw (not shown) (4 req'd)	215	Nameplate		
86	Machine Screw (2 req'd)	- - -	Pipe Plug, 2052		
* Recommended spare parts					

## Heat Insulator (Figure 12)

### NOTE

All Heat Insulator parts are included in the Heat Insulator Parts Kit.

Key	Description
35	Heat Insulator Assembly
36	Shaft Coupling
37	Shaft extension
38	Set screw (2 req'd)
39	Cap screw (4 req'd)
40	Cap screw (4 req'd)
53	Washer (4 req'd)

 [LinkedIn.com/groups/3941826](https://www.linkedin.com/groups/3941826)  
 [Fisher.com](http://www.fisher.com)

 [Facebook.com/FisherValves](https://www.facebook.com/FisherValves)  
 [Twitter.com/FisherValves](https://twitter.com/FisherValves)

D200126X012 © 2007, 2024 Fisher Controls International LLC. All rights reserved.

**Neither Emerson, nor any of its affiliated entities assume responsibility for the selection, use or maintenance of any product. Responsibility for proper selection, use, and maintenance of any product remains solely with the purchaser and end user.**

Fisher is a mark owned by one of the companies in the Emerson business unit of Emerson Electric Co. Emerson and the Emerson logo are trademarks and service marks of Emerson Electric Co. All other marks are the property of their respective owners.

The contents of this publication are presented for informational purposes only, and while every effort has been made to ensure their accuracy, they are not to be construed as warranties or guarantees, express or implied, regarding the products or services described herein or their use or applicability. All sales are governed by our terms and conditions, which are available upon request. We reserve the right to modify or improve the designs or specifications of such products at any time without notice.

Emerson  
Marshalltown, Iowa 50158 USA  
Sorocaba, 18087 Brazil  
Cernay, 68700 France  
Dubai, United Arab Emirates  
Singapore 128461 Singapore

[www.fisher.com](http://www.fisher.com)

**FISHER™**

  
**EMERSON™**