

# Fisher™ FIELDVUE™ DVC6200 Digital Valve Controller



This manual applies to:

<b>Instrument Level</b>	HC, AD, PD, ODV	
<b>Device Type</b>	1309	
<b>Hardware Revision</b>	2	
<b>Firmware Revision</b>	7	
<b>Device Revision</b>	1	3
<b>DD Revision</b>	7	1

# Table of Contents

## Section 1: Introduction

1.1	Installation, Pneumatic and Electrical Connections and Initial Configuration .....	2
1.2	Scope of the Manual .....	2
1.3	Conventions Used in this Manual .....	2
1.4	Description .....	3
1.5	Specifications .....	5
1.6	Related Documents .....	9
1.7	Educational Services .....	9

## Section 2: Wiring Practices

2.1	Control System Requirements .....	10
2.2	Voltage Available .....	11
2.3	Compliance Voltage .....	13
2.4	Auxiliary Terminal Wiring Length Guidelines .....	14
2.5	Maximum Cable Capacitance .....	15
2.6	Installation in Conjunction with a Rosemount 333 HART Tri-Loop HART-to-Analog Signal Converter .....	15

## Section 3: Configuration

3.1	Guided Setup .....	18
3.2	Manual Setup .....	18
3.3	Instrument .....	20
3.4	Travel/Pressure Control .....	23
3.5	Tuning .....	28
3.6	Valve and Actuator .....	32
3.7	Partial Stroke Test (PST) .....	35
3.8	Outputs .....	41
3.9	Alert Setup .....	43
3.10	Change to HART 5 / Change to HART 7 .....	44

## Section 4: Calibration

4.1	Travel Calibration .....	45
4.2	Sensor Calibration .....	48
4.3	Relay Adjustment .....	51
4.4	PST Calibration (ODV Instrument Level Only) .....	53

<b>Section 5: Device Information, Alerts and Diagnostics</b>	
5.1 Overview .....	54
5.2 Service Tools .....	55
5.3 Variables .....	64
<b>Section 6: Maintenance and Troubleshooting</b>	
6.1 Removing the Magnetic Feedback Assembly.....	67
6.2 Module Base Maintenance.....	67
6.3 Submodule Maintenance.....	70
6.4 Terminal Box .....	75
6.5 Troubleshooting.....	77
6.6 Checking Voltage Available.....	77
6.7 Restart Processor .....	78
6.8 DVC6200 Technical Support Checklist .....	81
<b>Section 7: Parts</b>	
7.1 Parts Ordering.....	82
7.2 Parts Kits.....	82
7.3 Parts List .....	86
<b>Appendix A: Principle of Operation</b> .....	96
<b>Appendix B: Handheld Communicator Menu Trees</b> .....	100
<b>Glossary</b> .....	108

# Section 1: Introduction

## 1.1 Installation, Pneumatic and Electrical Connections and Initial Configuration

Refer to the DVC6200 Series Quick Start Guide (D103556X012) for DVC6200 installation, connection and initial configuration information. If a copy of this quick start guide is needed, scan the QR code at the right, contact your Emerson sales office or visit our website at Fisher.com.



## 1.2 Scope of the Manual

This instruction manual is a supplement to the DVC6200 Series Quick Start Guide (D103556X012) that ships with every instrument. This instruction manual includes product specifications, reference materials, custom setup information, maintenance procedures and replacement part details.

This instruction manual describes using an Emerson handheld communicator to set up and calibrate the instrument. You can also use Fisher ValveLink™ software or ValveLink Mobile software to setup, calibrate and diagnose the valve and instrument. For information on using ValveLink software with the instrument refer to ValveLink software help or documentation.

### WARNING



**Do not install, operate or maintain a DVC6200 digital valve controller without being fully trained and qualified in valve, actuator and accessory installation, operation and maintenance. To avoid personal injury or property damage, it is important to carefully read, understand and follow all of the contents of this manual, including all safety cautions and warnings. If you have any questions about these instructions, contact your Emerson sales office before proceeding.**

## 1.3 Conventions Used in this Manual

Navigation paths are included for procedures and parameters that can be accessed using the handheld communicator. For example, to access Device Setup:

**Handheld Communicator**

Configure > Guided Setup > Device Setup

Refer to Appendix B for handheld communicator menu trees.

## 1.4 Description

DVC6200 digital valve controllers (Figures 1 and 2) are communicating, microprocessor-based current-to-pneumatic instruments. In addition to the traditional function of converting an input current signal to a pneumatic output pressure, the DVC6200 digital valve controller, using the HART® communications protocol, gives easy access to information critical to process operation. You can gain information from the principal component of the process, the control valve itself, using the handheld communicator at the valve, or at a field junction box, or by using a personal computer or operator's console within the control room. Additionally, an option is available which provides isolated circuitry for a valve position transmitter (for separate valve position feedback) or an integrated switch that can be set as a limit switch or an alert switch.

Using a personal computer and ValveLink software or AMS Suite: Intelligent Device Manager, or a handheld communicator, you can perform several operations with the DVC6200 digital valve controller. You can obtain general information concerning software revision level, messages, tag, descriptor and date.

Diagnostic information is available to aid you when troubleshooting. Input and output configuration parameters can be set, and the digital valve controller can be calibrated. Refer to Table 1 for details on the capabilities of each diagnostic tier.

Using the HART protocol, information from the field can be integrated into control systems or be received on a single loop basis.

The DVC6200 digital valve controller is designed to directly replace standard pneumatic and electro-pneumatic valve mounted positioners.

**Figure 1. FIELDVUE DVC6200 Digital Valve Controller Mounted on a Fisher Sliding-Stem Valve Actuator**



X1182-1

**Figure 2. FIELDVUE DVC6200 Digital Valve Controller Integrally Mounted to a Fisher GX Control Valve**



W9616

**Table 1. Instrument Level Capabilities**

CAPABILITY	DIAGNOSTIC LEVEL <sup>(2)</sup>			
	HC	AD	PD	ODV
Auto Calibration	X	X	X	X
Custom Characterization	X	X	X	X
Burst Communication	X	X	X	X
Alerts	X	X	X	X
Step Response, Drive Signal Test and Dynamic Error Band		X	X	X
Advanced Diagnostics (Valve Signature)		X	X	X
Performance Tuner <sup>(3)</sup>		X	X	X
Travel Control - Pressure Fallback		X	X	X
Supply Pressure Sensor	X <sup>(4)</sup>	X	X	X
Performance Diagnostics			X	X
Solenoid Valve Testing			X	X
Lead/Lag Set Point Filter <sup>(1)</sup>				X

1. Refer to brochure part # [D351146X012](#) for information on Fisher optimized digital valves for compressor antisurge applications.  
 2. HC = HART Communicating ; AD = Advanced Diagnostics ; PD = Performance Diagnostics ; ODV = Optimized Digital Valve.  
 3. Performance Tuner is only available in ValveLink software.  
 4. Supply Pressure Sensor available starting with Firmware 7.

## 1.5 Specifications

### WARNING

**Refer to Table 2 for specifications. Incorrect configuration of a positioning instrument could result in the malfunction of the product, property damage or personal injury.**

Specifications for DVC6200 digital valve controllers are shown in Table 2. Specifications for the Device Communicator can be found in the Device Communicator [quick start guide](#).

**Table 2. Specifications**

Available Mounting	Supply Pressure <sup>(1)</sup>
<p>DVC6200 digital valve controller or DVC6215 feedback unit: ■ Integral mounting to Fisher 657/667 or GX actuators ■ Window mounting to Fisher rotary actuators ■ Sliding-stem linear applications ■ Quarter-turn rotary applications</p> <p>DVC6205 base unit for 2 in. pipestand or wall mounting (for remote-mount)</p> <p>The DVC6200 digital valve controller or DVC6215 feedback unit can also be mounted on other actuators that comply with IEC 60534-6-1, IEC 60534-6-2, VDI/VDE 3845 and NAMUR mounting standards.</p>	<p>Minimum Recommended: 0.3 bar / 5 psig higher than maximum actuator requirements</p> <p>Maximum: 10.0 bar / 145 psig or maximum pressure rating of the actuator, whichever is lower</p> <p>Medium: Air or Natural Gas</p> <p>Supply medium must be clean, dry and noncorrosive.</p> <p><b>Per ISA Standard 7.0.01</b></p> <p>A maximum 40 micrometer particle size in the air system is acceptable. Further filtration down to 5 micrometer particle size is recommended. Lubricant content is not to exceed 1 ppm weight (w/w) or volume (v/v) basis. Condensation in the air supply should be minimized.</p> <p>Pressure Dew Point: at least 10 °C less than the lowest ambient temperature expected.</p> <p><b>Per ISO 8573-1</b></p> <p>Maximum particle density size: Class 7</p> <p>Oil content: Class 3</p> <p>Pressure Dew Point: Class 3</p>
Communication Protocol	
<p>■ HART 5 or ■ HART 7</p>	
Input Signal	
<p><b>Point-to-Point</b></p> <p>Analog Input Signal: 4 to 20 mA DC, nominal; split ranging available</p> <p>Minimum Voltage Available at Instrument Terminals must be 9.5 V DC for analog control, 10 V DC for HART communication</p> <p>Minimum Control Current: 4.0 mA</p> <p>Minimum Current without Microprocessor Restart: 3.5 mA</p> <p>Maximum Voltage: 30 V DC</p> <p>Overcurrent protected</p> <p>Reverse Polarity protected</p> <p><b>Multi-drop</b></p> <p>Instrument Power: 11 to 30 V DC at 10 mA</p> <p>Reverse Polarity protected</p>	
Output Signal	<p>Pneumatic signal, up to full supply pressure</p> <p>Minimum Span: 0.4 bar / 6 psig</p> <p>Maximum Span: 9.5 bar / 140 psig</p> <p>Action: ■ Double, ■ Single Direct or ■ Reverse</p>
	Steady-State Air Consumption <sup>(2)(3)</sup>
	<p><b>Standard Relay</b></p> <p>At 1.4 bar / 20 psig supply pressure: Less than 0.38 normal m<sup>3</sup>/hr / 14 scfh</p> <p>At 5.5 bar / 80 psig supply pressure: Less than 1.3 normal m<sup>3</sup>/hr / 49 scfh</p> <p><b>Low Bleed Relay</b></p> <p>At 1.4 bar / 20 psig supply pressure: Average value 0.056 normal m<sup>3</sup>/hr / 2.1 scfh</p> <p>At 5.5 bar / 80 psig supply pressure: Average value 0.184 normal m<sup>3</sup>/hr / 6.9 scfh</p>

- continued -

**Table 2. Specifications (continued)**

Maximum Output Capacity <sup>(2)(3)</sup>	Hazardous Area Approvals
At 1.4 bar / 20 psig supply pressure: 10.0 normal m <sup>3</sup> /hr / 375 scfh At 5.5 bar / 80 psig supply pressure: 29.5 normal m <sup>3</sup> /hr / 1100 scfh	CSA - Intrinsically Safe, Explosion-proof, Division 2, Dust Ignition-proof (Canada) FM - Intrinsically Safe, Explosion-proof, Dust Ignition-proof, Non-Incendive (United States)
Operating Ambient Temperature Limits <sup>(1)(4)</sup>	ATEX - Intrinsically Safe, Flameproof, Type n Dust by intrinsic safety IECEX - Intrinsically Safe, Flameproof, Type n Dust by intrinsic safety and enclosure Natural Gas Certified, Single Seal Device - CSA, FM, ATEX and IECEX Marine Approvals - Lloyds, DNV, ABS, Bureau Veritas CML - Certification Management Limited (Japan) CUTR - Customs Union Technical Regulations
-40 to 85 °C / -40 to 185 °F -52 to 85 °C / -62 to 185 °F for instruments utilizing the Extreme Temperature option (fluorosilicone elastomers) -52 to 125 °C / -62 to 257 °F for remote-mount feedback unit	ESMA - Emirates Authority for Standardization and Metrology - ECAS-Ex (UAE) INMETRO - National Institute of Metrology, Quality and Technology (Brazil) KOSHA - Korean Occupational Safety and Health Agency (South Korea) KTL - Korea Testing Laboratory (South Korea) CCC - China Compulsory Certification NEPSI - National Supervision and Inspection Centre for Explosion Protection and Safety of Instrumentation (China) PESO CCOE - Petroleum and Explosives Safety Organisation - Chief Controller of Explosives (India) SANS - South Africa National Standards UKEx - Intrinsically Safe and Dust, Flameproof, Dust by Enclosure, Type n (United Kingdom) Not all certifications apply to all constructions. Contact your Emerson sales office or refer to the DVC6200 product page at Fisher.com for approval specific information
Independent Linearity <sup>(5)</sup>	
Typical Value: ±0.50% of output span	
Electromagnetic Compatibility	
Meets EN 61326-1:2021 Immunity—Industrial locations per Table 2 of the EN 61326-1 standard. Performance is shown in Table 3. Emissions—Class A ISM equipment rating: Group 1, Class A Lightning and Surge Protection—The degree of immunity to lightning is specified as Surge immunity in Table 3. For additional surge protection, commercially available transient protection devices can be used.	
Vibration Testing Method	Electrical Housing
Tested per ANSI/ISA-S75.13.01 Section 5.3.5. A resonant frequency search is performed on all three axes. The instrument is subjected to the ISA specified 1/2 hour endurance test at each major resonance.	CSA - Type 4X, IP66 FM - Type 4X, IP66 ATEX - IP66 IECEX - IP66
Input Impedance	Connections
An equivalent impedance of 500 ohms may be used. This value corresponds to 10 V at 20 mA.	Supply Pressure: 1/4 NPT internal and integral pad for mounting 67CFR regulator Output Pressure: 1/4 NPT internal Tubing: 3/8-in. recommended Vent: 3/8 NPT internal Electrical: 1/2 NPT internal or M20
Humidity Testing Method	
Tested per IEC 61514-2	

- continued -



**Table 2. Specifications (continued)**

Actuator Compatibility	Options		
Sliding-Stem Linear Linear actuators with rated travel between 6.35 mm / 0.25 in. and 606 mm / 23.375 in. Quarter-Turn Rotary Rotary actuators with rated travel between 45° and 180° <sup>(6)</sup>	<ul style="list-style-type: none"> <li>■ Supply and output pressure gauges or</li> <li>■ Tire valves ■ Integral mounted filter regulator</li> <li>■ Low-Bleed Relay<sup>(7)</sup> ■ Extreme Temperature</li> <li>■ Remote Mount<sup>(8)</sup> ■ Stainless Steel</li> <li>■ <b>Integral 4 to 20 mA Position Transmitter<sup>(9)</sup>:</b>                          4 to 20 mA output, isolated                          Supply Voltage: 8 to 30 V DC                          Reference Accuracy: 1% of travel span                          The position transmitter meets the requirements of NAMUR NE43; selectable to show failure high (&gt; 22.5 mA) or failure low (&lt; 3.6 mA). Fail high only when the positioner is powered.</li> </ul>		
Weight	<ul style="list-style-type: none"> <li>■ <b>Integral Switch<sup>(9)</sup>:</b>                          One isolated switch, configurable throughout the calibrated travel range or actuated from a device alert                          Off State: 0 mA (nominal)                          On State: up to 1 A                          Supply Voltage: 30 V DC maximum                          Reference Accuracy: 2% of travel span                          Contact your <a href="#">Emerson sales office</a> or go to <a href="#">Fisher.com</a> for additional information.</li> </ul>		
DVC6200 Aluminum: 3.5 kg / 7.7 lbs Stainless Steel: 8.6 kg / 19 lbs DVC6205: 4.1 kg / 9 lbs DVC6215: 1.4 kg / 3.1 lbs	<th data-bbox="293 1035 862 1081">Construction Materials</th> <th data-bbox="862 1035 1425 1081">Declaration of SEP</th>	Construction Materials	Declaration of SEP
Housing, module base and terminal box: A03600 low copper aluminum alloy (standard) Stainless steel (optional) Cover: Thermoplastic polyester Elastomers: Nitrile (standard) Fluorosilicone (extreme temperature)	Fisher Controls International LLC declares this product to be in compliance with Article 4 paragraph 3 of the PED Directive 2014/68/EU and Part 1, Requirement 8 of the PESR Regulation. It was designed and manufactured in accordance with Sound Engineering Practice (SEP) and cannot bear the CE marking related to PED compliance or the UKCA mark related to the PESR Regulation. However, the product may bear the CE or UKCA marking to indicate compliance with other applicable European Community Directives or UK Regulations (Statutory Instruments).		
<p><b>NOTE:</b> Specialized instrument terms are defined in ANSI/ISA Standard 51.1 - Process Instrument Terminology.</p> <ol style="list-style-type: none"> <li>1. The pressure/temperature limits in this document and any other applicable code or standard should not be exceeded.</li> <li>2. Normal m<sup>3</sup>/hour - Normal cubic meters per hour at 0 °C and 1.01325 bar, absolute. Scfh - Standard cubic feet per hour at 60 °F and 14.7 psia.</li> <li>3. Values at 1.4 bar / 20 psig based on a single-acting direct relay; values at 5.5 bar / 80 psig based on double-acting relay.</li> <li>4. Temperature limits vary based on hazardous area approval. Lower temperature limit for CUTR Ex d approval with fluorosilicone elastomers is -53 °C / -63.4 °F.</li> <li>5. Not applicable for travels less than 19 mm / 0.75 in. or for shaft rotation less than 60°. Also not applicable for digital valve controllers in long-stroke applications.</li> <li>6. Rotary actuators with 180° rated travel require a special mounting kit; contact your Emerson sales office for kit availability.</li> <li>7. The Quad O steady-state consumption requirement of 6 scfh can be met by a DVC6200 with low bleed relay A option, when used with up to 4.8 bar / 70 psi supply of Natural Gas at 16 °C / 60 °F. The 6 scfh requirement can be met by low bleed relay B and C when used with up to 5.2 bar / 75 psi supply of Natural Gas at 16 °C / 60 °F.</li> <li>8. 4-conductor shielded cable, 18 to 22 AWG minimum wire size, in rigid or flexible metal conduit, is required for connection between base unit and feedback unit. Pneumatic tubing between base unit output connection and actuator has been tested to 91 m / 300 ft with minimal pneumatic lag. At 15 m / 50 ft there was no performance degradation.</li> <li>9. The electronic output is available with either the position transmitter or the integral switch.</li> </ol>			

**Table 3. EMC Summary Results—Immunity**

Port	Phenomenon	Basic Standard	Test Level	Performance Criteria <sup>(1)</sup>
Enclosure	Electrostatic discharge (ESD)	IEC 61000-4-2	4 kV contact 8 kV air	A - without I/O B - with I/O
	Radiated EM field	IEC 61000-4-3	80 to 1000 MHz at 10 V/m with 1 kHz AM at 80% 1400 to 2000 MHz at 10 V/m with 1 kHz AM at 80% 2000 to 2700 MHz at 10 V/m with 1 kHz AM at 80% 2700 to 6000 MHz at 10 V/m with 1 kHz AM at 80% <sup>(2)</sup>	A
	Rated power frequency	IEC 61000-4-8	30 A/m at 50/60Hz	A
I/O signal/control	Burst	IEC 61000-4-4	1 kV	A - without I/O B - with I/O
	Surge	IEC 61000-4-5	1 kV	A - without I/O B - with I/O
	Conducted RF	IEC 61000-4-6	150 kHz to 80 MHz at 3 Vrms	A
Performance criteria DVC6200: +/- 1% DVC6205 Remote Mount: +/- 2% 1. A = No degradation during testing. B = Temporary degradation during testing, but is self-recovering. 2. Supplementary immunity testing performed from 1.4 GHz to 10 GHz to meet EN 61326-1:2021 requirements.				

## 1.6 Related Documents

This section lists other documents containing information related to the DVC6200 digital valve controller. These documents include:

- Fisher FIELDVUE DVC6200 PD Digital Valve Controller Product Bulletin ([D103415X012](#))
- Fisher FIELDVUE DVC6200 Digital Valve Controller Dimensions ([D103543X012](#))
- Fisher FIELDVUE Digital Valve Controller Product Selection ([D104363X012](#))
- Fisher FIELDVUE DVC6200 Series Digital Valve Controller Quick Start Guide ([D103556X012](#))
- FIELDVUE Digital Valve Controller Split Ranging ([D103262X012](#))
- Using FIELDVUE Instruments with the Smart HART Loop Interface and Monitor (HIM) ([D103263X012](#))
- Using FIELDVUE Instruments with the Smart Wireless THUM Adapter and a HART Interface Module (HIM) ([D103469X012](#))
- Audio Monitor for HART Communications ([D103265X012](#))
- HART Field Device Specification - Supplement to Fisher FIELDVUE DVC6200 Digital Valve Controller ([D103639X012](#))
- Using the HART Tri-Loop HART-to-Analog Signal Converter with FIELDVUE Digital Valve Controllers ([D103267X012](#))
- Implementation of Lock-in-Last Strategy ([D103261X012](#))
- Fisher HF340 Filter Instruction Manual ([D102796X012](#))
- AMS Trex Device Communicator [User Guide](#)
- ValveLink Software Help or [Documentation](#)

All documents are available from your [Emerson sales office](#) or at [Fisher.com](#).

## 1.7 Educational Services

Emerson Educational Services  
Phone: +1-800-338-8158  
E-mail: [education@emerson.com](mailto:education@emerson.com)  
[emerson.com/mytraining](http://emerson.com/mytraining)

## Section 2: Wiring Practices

### 2.1 Control System Requirements

There are several parameters that should be checked to ensure the control system is compatible with the DVC6200 digital valve controller.

#### HART Filter

Depending on the control system you are using, a HART filter may be needed to allow HART communication. The HART filter is a passive device that is inserted in field wiring from the HART loop. The filter is normally installed near the field wiring terminals of the control system I/O (see Figure 3). Its purpose is to effectively isolate the control system output from modulated HART communication signals and raise the impedance of the control system to allow HART communication. For more information on the description and use of the HART filter, refer to the appropriate HART filter instruction manual.

To determine if your system requires a filter contact your [Emerson sales office](#).

---

#### NOTE

A HART filter is typically NOT required for any of the Emerson control systems, including PROVOX™, RS3™ and DeltaV™ systems.

---

**Figure 3. HART Filter Application**

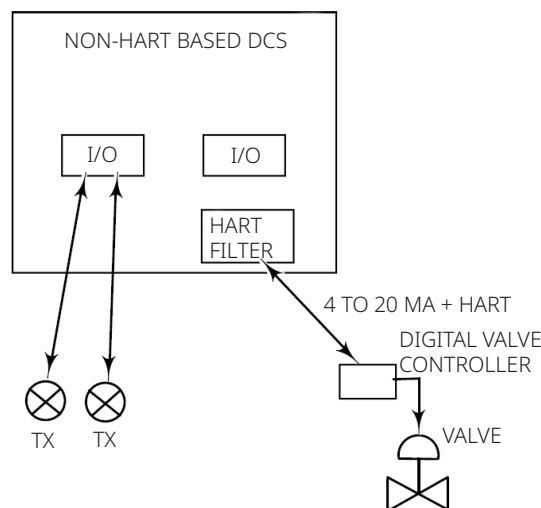

A6188-1

---

## 2.2 Voltage Available

The voltage available at the DVC6200 digital valve controller must be at least 10 V DC. The voltage available at the instrument is not the actual voltage measured at the instrument when the instrument is connected. The voltage measured at the instrument is limited by the instrument and is typically less than the voltage available.

As shown in Figure 4, the voltage available at the instrument depends upon:

- the control system compliance voltage
- if a filter, wireless THUM adapter or intrinsic safety barrier is used, and
- the wire type and length.

The control system compliance voltage is the maximum voltage at the control system output terminals at which the control system can produce maximum loop current.

The voltage available at the instrument may be calculated from the following equation:

Voltage Available = [Control System Compliance Voltage (at maximum current)] - [filter voltage drop (if a HART filter is used)] - [total cable resistance x maximum current] - [barrier resistance x maximum current].

The calculated voltage available should be greater than or equal to 10 V DC.

Table 4 lists the resistance of some typical cables.

The following example shows how to calculate the voltage available for a Honeywell™ TDC2000 control system with a HF340 HART filter and 1000 ft of Belden™ 9501 cable:

Voltage available = [18.5 V (at 21.05 mA)] - [2.3 V] - [48 ohms x 0.02105 A]

Voltage available = [18.5] - [2.3] - [1.01]

Voltage available = 15.19 V

**Figure 4. Determining Voltage Available at the Instrument**

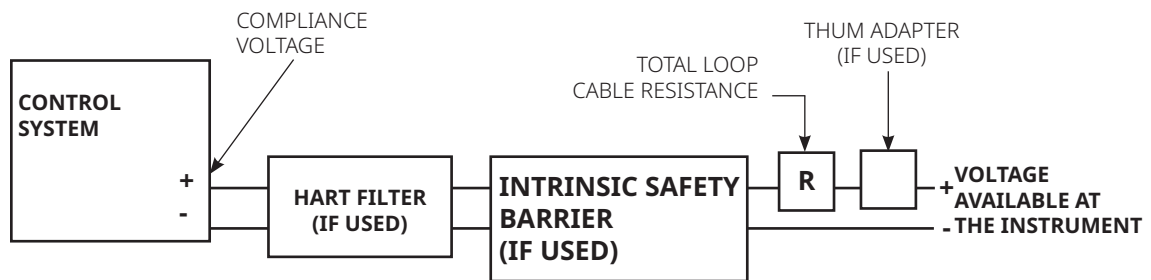

Calculate Voltage Available at the Instrument as follows:

Control system compliance voltage

- Filter voltage drop (if used)<sup>(1)</sup>

- Intrinsic safety barrier resistance (if used) x maximum loop current

- Smart Wireless THUM adapter voltage drop (if used)<sup>(2)</sup>

- Total loop cable resistance x maximum loop current

= Voltage available at the instrument<sup>(3)</sup>

Example Calculation

18.5 V (at 21.05 mA)

- 2.3 V (for HF340 filter)

- 2.55 V (121 ohms x 0.02105 A)

- 1.01 V (48 ohms x 0.02105 A for 1000 feet of Belden 9501 cable)

= 15.19 V, available — if safety barrier (2.55 V) is not used

Notes:

1. Obtain filter voltage drop. The measured drop will be different than this value. The measured filter voltage drop depends upon control system output voltage, the intrinsic safety barrier (if used), and the instrument. See Note 3.
2. The voltage drop of the THUM adapter is linear from 2.25 V at 3.5 mA to 1.2 V at 25 mA.
3. The voltage available at the instrument is not the voltage measured at the instrument terminals. Once the instrument is connected, the instrument limits the measured voltage to approximately 8.0 to 9.5 V.

**Table 4. Cable Characteristics**

Cable Type	Capacitance <sup>(1)</sup> pF/Ft	Capacitance <sup>(1)</sup> pF/m	Resistance <sup>(2)</sup> Ohms/ft	Resistance <sup>(2)</sup> Ohms/m
BS5308/1, 0.5 sq mm	61.0	200	0.022	0.074
BS5308/1, 1.0 sq mm	61.0	200	0.012	0.037
BS5308/1, 1.5 sq mm	61.0	200	0.008	0.025
BS5308/2, 0.5 sq mm	121.9	400	0.022	0.074
BS5308/2, 0.75 sq mm	121.9	400	0.016	0.053
BS5308/2, 1.5 sq mm	121.9	400	0.008	0.025
BELDEN 8303, 22 awg	63.0	206.7	0.030	0.098
BELDEN 8441, 22 awg	83.2	273	0.030	0.098

- continued -

**Table 4. Cable Characteristics (continued)**

Cable Type	Capacitance <sup>(1)</sup> pF/Ft	Capacitance <sup>(1)</sup> pF/m	Resistance <sup>(2)</sup> Ohms/ft	Resistance <sup>(2)</sup> Ohms/m
BELDEN 8767, 22 awg	76.8	252	0.030	0.098
BELDEN 8777, 22 awg	54.9	180	0.030	0.098
BELDEN 9501, 24 awg	50.0	164	0.048	0.157
BELDEN 9680, 24 awg	27.5	90.2	0.048	0.157
BELDEN 9729, 24 awg	22.1	72.5	0.048	0.157
BELDEN 9773, 18 awg	54.9	180	0.012	0.042
BELDEN 9829, 24 awg	27.1	88.9	0.048	0.157
BELDEN 9873, 20 awg	54.9	180	0.020	0.069

1. The capacitance values represent capacitance from one conductor to all other conductors and shield. This is the appropriate value to use in the cable length calculations.  
 2. The resistance values include both wires of the twisted pair.

## 2.3 Compliance Voltage

If the compliance voltage of the control system is not known, perform the following compliance voltage test.

1. Disconnect the field wiring from the control system and connect equipment as shown in Figure 5 to the control system terminals.

**Figure 5. Voltage Test Schematic**

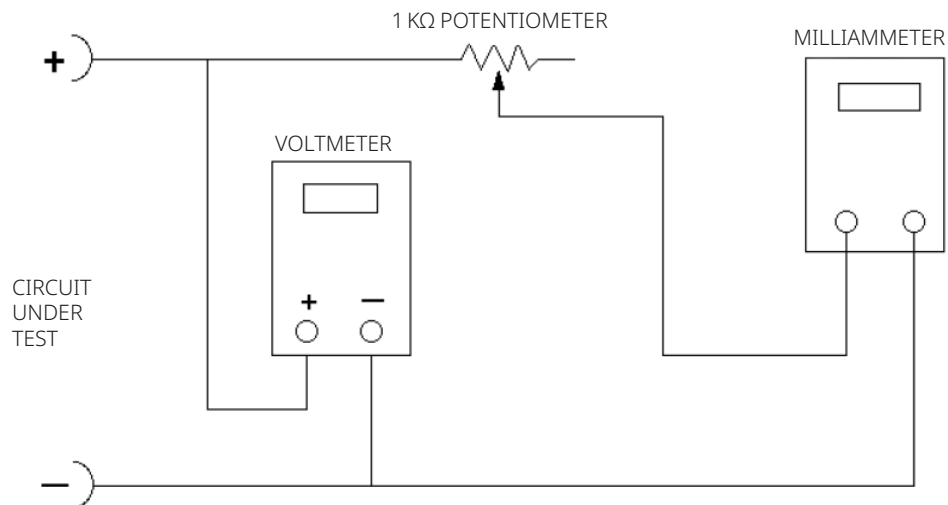

A6192-1

2. Set the control system to provide maximum output current.
3. Increase the resistance of the 1 k $\Omega$  potentiometer, shown in Figure 5, until the current observed on the milliammeter begins to drop quickly.
4. Record the voltage shown on the voltmeter. This is the control system compliance voltage.

For specific parameter information relating to your control system, contact your [Emerson sales office](#).

## 2.4 Auxiliary Terminal Wiring Length Guidelines

The Auxiliary Input Terminals of a DVC6200 with instrument level ODV can be used with a locally-mounted switch for initiating a partial stroke test. Some applications require that the switch be installed remotely from the DVC6200.

The length for wiring connected to the Auxiliary Input Terminals is limited by capacitance. For proper operation of the Auxiliary Input Terminals capacitance should not exceed 100,000 pF. As with all control signal wiring, good wiring practices should be observed to minimize adverse effect of electrical noise on the Aux Switch function.

Example Calculation: Capacitance per foot or per meter is required to calculate the length of wire that may be connected to the Aux switch input. The wire should not exceed the capacitance limit of 100,000 pF. Typically the wire manufacturer supplies a data sheet which provides all of the electrical properties of the wire. The pertinent parameter is the highest possible capacitance. If shielded wire is used, the appropriate number is the "Conductor to Other Conductor and Shield" value.

### Example — 18AWG Unshielded Audio, Control and Instrumentation Cable

Manufacturer's specifications include:

Nom. Capacitance Conductor to Conductor at 1 KHz: 26 pF/ft

Nom. Conductor DC Resistance at 20 °C: 5.96 Ohms/1000 ft

Max. Operating Voltage - UL 200 V RMS (PLTC, CMG), 150 V RMS (ITC)

Allowable Length with this cable =  $100,000\text{pF} / (26 \text{ pF/ft}) = 3846 \text{ ft}$

### Example — 18AWG Shielded Audio, Control and Instrumentation Cable

Manufacturer's specifications include:

Nom. Characteristic Impedance: 29 Ohms

Nom. Inductance: .15  $\mu\text{H/ft}$

Nom. Capacitance Conductor to Conductor at 1 KHz: 51 pF/ft

Nom. Cap. Cond. to other Cond. and Shield at 1 KHz 97 pF/ft

Allowable Length with this cable =  $100,000 \text{ pF} / (97 \text{ pF/ft}) = 1030 \text{ ft}$

The AUX switch input passes less than 1 mA through the switch contacts, and uses less than 5V, therefore, neither the resistance nor the voltage rating of the cable are critical. Ensure that switch contact corrosion is prevented. It is generally advisable that the switch have gold-plated or sealed contacts.



## 2.5 Maximum Cable Capacitance

The maximum cable length for HART communication is limited by the characteristic capacitance of the cable. Maximum length due to capacitance can be calculated using the following formulas:

$$\text{Length(ft)} = [160,000 - C_{\text{master}}(\text{pF})] \div [C_{\text{cable}}(\text{pF/ft})]$$

$$\text{Length(m)} = [160,000 - C_{\text{master}}(\text{pF})] \div [C_{\text{cable}}(\text{pF/m})]$$

where:

160,000 = a constant derived for FIELDVUE instruments to ensure that the HART network RC time constant will be no greater than 65  $\mu\text{s}$  (per the HART specification).

$C_{\text{master}}$  = the capacitance of the control system or HART filter

$C_{\text{cable}}$  = the capacitance of the cable used (see Table 4)

The following example shows how to calculate the cable length for a Foxboro™ I/A control system (1988) with a  $C_{\text{master}}$  of 50,000 pF and a Belden 9501 cable with characteristic capacitance of 50 pF/ft.

$$\text{Length(ft)} = [160,000 - 50,000 \text{ pF}] \div [50 \text{ pF/ft}]$$

$$\text{Length} = 2200 \text{ ft.}$$

The HART communication cable length is limited by the cable characteristic capacitance. To increase cable length, select a wire with lower capacitance per foot. Contact your [Emerson sales office](#) for specific information relating to your control system.

## 2.6 Installation in Conjunction with a Rosemount 333 HART Tri-Loop HART-to-Analog Signal Converter

Use the DVC6200 digital valve controller in operation with a Rosemount 333 HART Tri-Loop HART-to-Analog Signal Converter to acquire an independent 4 to 20 mA analog output signal for the analog input, travel target, pressure or travel. The HART Tri-Loop accepts any three of these digital signals and converts them into three separate 4 to 20 mA analog channels.

Refer to Figure 6 for basic installation information. Refer to the 333 HART Tri-Loop HART-to-Analog Signal Converter Product Manual (00809-0100-4754) for complete installation information.

**Figure 6. HART Tri-Loop Installation Flowchart**

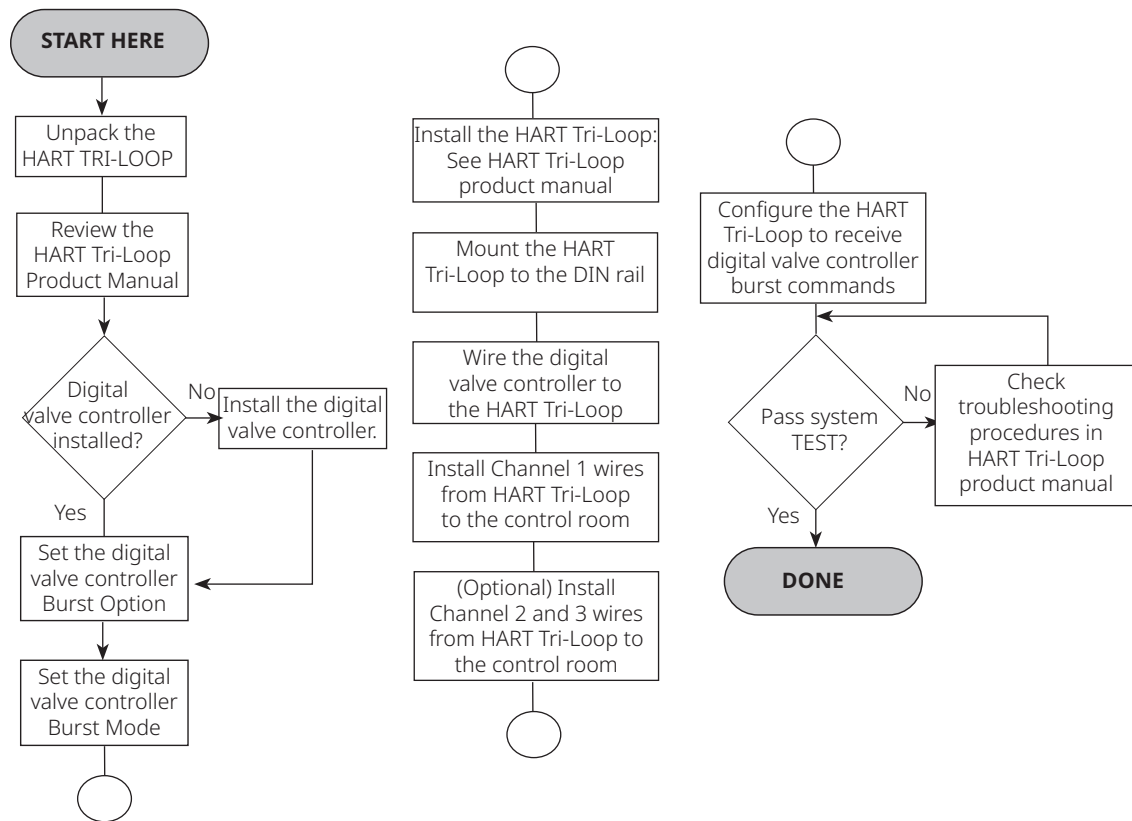

E0365

## Commissioning the Digital Valve Controller for use with the HART Tri-Loop Signal Converter

To prepare the digital valve controller for use with a 333 HART Tri-Loop, you must configure the digital valve controller to burst mode, and select Burst Command 3. In burst mode, the digital valve controller provides digital information to the HART Tri-Loop HART-to-Analog Signal Converter. The HART Tri-Loop converts the digital information to a 4 to 20 mA analog signal. Each burst message contains the latest value of the primary (analog input), secondary (travel target), tertiary (configured output pressure) and quaternary (travel) variables.

To commission a DVC6200 for use with a HART Tri-Loop, perform the following procedures.

## Enable Burst Operation

<b>Handheld Communicator</b>	With I/O Package Configure > Manual Setup > Outputs > Burst Mode
	Without I/O Package Configure > Manual Setup > Outputs > Burst Mode

Select Burst Enable and follow the prompts to enable burst mode. Then select Burst Command and follow the prompts to configure Loop Current/PV/SV/TV/QV.

## Select the HART Variable Assignments

<b>Handheld Communicator</b>	With I/O Package Configure > Manual Setup > Outputs > HART Variable Assignments
	Without I/O Package Configure > Manual Setup > Outputs > HART Variable Assignments

Configure the HART Variable Assignments. The Primary Variable (PV) is always Analog Input. The Secondary Variable (SV), Tertiary Variable (TV) and Quaternary Variable (QV) can be configured to any of the following variables. The variable assignments in the DVC6200 must correspond to the variable assignments in the Tri-Loop.

- Setpoint
- Travel (see note below)
- Pressure A
- Pressure B
- Pressure AB
- Supply Pressure
- Drive Signal
- Analog Input

---

### NOTE

If the instrument is configured to operate in pressure control mode, or detects an invalid travel sensor reading, the Travel variable will report pressure in percent of bench set range.

---

## Section 3: Configuration

### 3.1 Guided Setup

#### Handheld Communicator

Configure > Guided Setup

To quickly setup the instrument, the following procedures will guide you through the process.

Device Setup is used to configure the unique parameters for the valve, actuator, instrument and accessory construction. After Device Setup is complete, proceed with Auto Calibration.

Auto Calibration is used to establish the limits of physical travel. During this process, the valve will fully stroke from one travel extreme to the other. There are three calibration options to choose from:

- Autocalibrate – Standard runs the full calibration process (recommended).
- Autocalibrate – Without Biases establishes the travel end points, but does not adjust the Minor Loop Feedback bias. This is for advanced use when manually setting the biases for large actuators.
- Advanced Settings allows additional custom configuration of calibration parameters. This is for advanced use when calibrating large actuators.

### 3.2 Manual Setup

Manual Setup allows you to configure the digital valve controller to your application. Table 5 lists the default settings for a standard factory configuration. You can adjust actuator response, set the various modes, alerts, ranges, travel cutoffs and limits. You can also restart the instrument and set the protection.

**Table 5. Default Detailed Setup Parameters**

	Setup Parameter	Default Setting(1)
Instrument Configuration	Control Mode	Analog
	Restart Control Mode	Resume Last
	Analog In Range Low	4 mA
	Analog In Range High	20 mA
	Analog Input Units	mA
	Local AutoCal Button	Enabled
	Polling Address	0
	Burst Mode Enable	No
	Burst Command	3
	Cmd 3 (Trending) Pressure	A-B

- continued -

**Table 5. Default Detailed Setup Parameters (continued)**

	Setup Parameter	Default Setting <sup>(1)</sup>
Dynamic Response and Tuning	Input Characterization	Linear
	Travel Limit High	125%
	Travel Limit Low	-25%
	Travel/Pressure Cutoff High	99.46%
	Travel/Pressure Cutoff Low	0.50%
	Set Point Rate Open	0%/second
	Set Point Rate Close	0%/second
	Set Point Filter Time (Lag Time)	0 seconds
	Integrator Enable	Yes
	Integral Gain	9.4 repeats/minute
Deviation and Other Alerts	Integral Deadzone	0.26%
	Travel Deviation Alert Enable	Yes
	Travel Deviation Alert Point	5%
	Travel Deviation Time	9.99 seconds
	Pressure Deviation Alert Enable	Yes
	Pressure Deviation Alert Point	5 psi <sup>(2)</sup>
	Pressure Deviation Alert Time	5.0 seconds
	Drive Signal Alert Enable	Yes
Supply Pressure Alert Enable	Yes	
<p>1. The settings listed are for standard factory configuration. DVC6200 instruments can also be ordered with custom configuration settings. Refer to the order requisition for the custom settings.</p> <p>2. Adjust to bar, kPa or Kg/cm<sup>2</sup>, if necessary.</p>		

## Mode and Protection

<b>Handheld Communicator</b>	Configure > Manual Setup > Mode and Protection
------------------------------	--

### Instrument Mode

There are two instrument modes for the DVC6200; In Service or Out of Service. In Service is the normal operating mode such that the instrument follows the 4 to 20 mA control signal. Out of Service is required in some cases to modify configuration parameters or to run diagnostics.

---

**NOTE**

Some changes that require the instrument to be taken Out Of Service will not take effect until the instrument is placed back In Service or the instrument is restarted.

---

## Write Protection

There are two Write Protection modes for the DVC6200: Not Protected or Protected. Protected prevents configuration and calibration changes to the instrument. The default setting is Not Protected. Write Protection can be changed to Protected remotely. However, to change Write Protection to Not Protected, you must have physical access to the instrument. The procedure will require you to press a button (  ) on the terminal box as a security measure.

## 3.3 Instrument

**Handheld Communicator**

Configure &gt; Manual Setup &gt; Instrument

Follow the prompts on the handheld communicator display to configure the following Instrument parameters:

### Identification

- **HART Tag**—A tag name up to 8 characters is available for the instrument. The HART tag is the easiest way to distinguish between instruments in a multi-instrument environment. Use the HART tag to label instruments electronically according to the requirements of your application. The tag you assign is automatically displayed when the handheld communicator establishes contact with the digital valve controller at power-up.
- **HART Long Tag (HART Universal Revision 7 only)**—A tag name up to 32 characters is available for the instrument.
- **Description**—Enter a description for the application with up to 16 characters. The description provides a longer user-defined electronic label to assist with more specific instrument identification than is available with the HART tag.
- **Message**—Enter any message with up to 32 characters. Message provides the most specific user-defined means for identifying individual instruments in multi-instrument environments.
- **Polling Address**—If the digital valve controller is used in point-to-point operation, the Polling Address is 0. When several devices are connected in the same loop, such as for split ranging, each device must be assigned a unique polling address. The Polling Address is set to a value between 0 and 63 for HART 7 and 0 and 15 for HART 5. To change the polling address the instrument must be Out Of Service.

For the handheld communicator to be able to communicate with a device whose polling address is not 0, it must be configured to automatically search for all or specific connected devices.

## Serial Numbers

- Instrument Serial Number—Enter the serial number on the instrument nameplate, up to 12 characters.
- Valve Serial Number—Enter the serial number for the valve in the application, up to 12 characters.

## Units

- Pressure Units—Defines the output and supply pressure units in either psi, bar, kPa or kg/cm<sup>2</sup>.
- Temperature Units—Degrees Fahrenheit or Celsius. The temperature measured is from a sensor mounted on the digital valve controller's printed wiring board.
- Analog Input Units—Permits defining the Analog Input Units in mA or percent of 4 to 20 mA range.

## Terminal Box

- Calibration (CAL) Button—This button is near the wiring terminals in the terminal box and provides a quick means to autocalibrate the instrument. The button must be pressed for 3 to 10 seconds. Autocalibration will move the valve through the full range of travel whether the Instrument Mode is In Service or Out of Service. However, if the Write Protection is Protected, this button will not be active. To abort, press the button again for 1 second. The calibration button is disabled by default.
- Auxiliary Terminal Action—These wire terminals can be configured to initiate a partial stroke test upon detection of a short across the (+) and (-) terminals. The terminals must be shorted for 3 to 10 seconds.

---

### NOTE

Auxiliary Terminal Action is only available for instrument level ODV.

---

## Analog Input Range

- Input Range Hi—Permits setting the Input Range High value. Input Range High should correspond to Travel Range High, if the Zero Power Condition is configured as closed. If the Zero Power Condition is configured as open, Input Range High corresponds to Travel Range Low. See Figure 7.
- Input Range Lo—Permits setting the Input Range Low value. Input Range Low should correspond to Travel Range Low, if the Zero Power Condition is configured as closed. If the Zero Power Condition is configured as open, Input Range Low corresponds to Travel Range High. See Figure 7.

**Figure 7. Calibrated Travel to Analog Input Relationship**

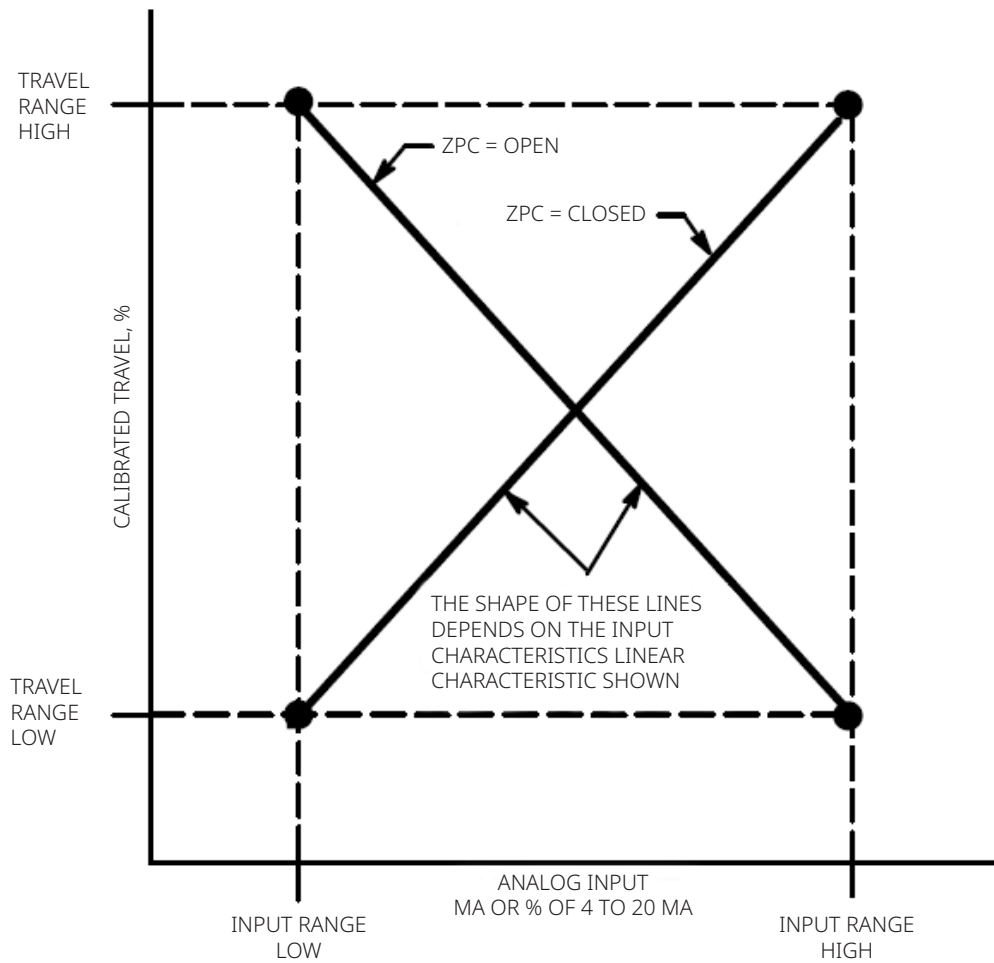

NOTE:

ZPC = ZERO POWER CONDITION

A6531-1

## Spec Sheet

The Spec Sheet provides a means to store the entire control valve specifications on board the DVC6200.

## Edit Instrument Time

Permits setting the instrument clock. When alerts are stored in the alert record, the record includes the time and date. The instrument clock uses a 24-hour format.



## 3.4 Travel/Pressure Control

### Handheld Communicator

Configure > Manual Setup > Travel/Pressure Control

### Travel/Pressure Select

This defines the operating mode of the instrument as well as the behavior of the instrument should the travel sensor fail. There are four choices.

- Travel Control—The instrument is controlling to a target travel. Fallback is not enabled.
- Pressure Control—The instrument is controlling to a target pressure. Fallback is not enabled.
- Fallback-Sensor Failure—The instrument will fallback to pressure control if a travel sensor failure is detected.
- Fallback-Sensor/Tvl Deviation—The instrument will fallback to pressure control if a travel sensor failure is detected, or if the Tvl Dev Press Fallback setting is exceeded for more than the Tvl Dev Press Fallback Time.

#### NOTE

Travel / Pressure Select must be set to Travel for double-acting actuators.

### Cutoffs and Limits

- Hi Limit/Cutoff Select—When the Hi Cutoff/Limit Select is configured for Cutoff, the Travel Target is set to 123% when the Travel exceeds the Hi Cutoff Point. When the Hi Cutoff/Limit Select is configured for Limit, the Travel Target will not exceed the Hi Limit Point.
- Hi Limit/Cutoff Point—This is the point within the calibrated travel range above which the Limit or Cutoff is in effect. When using cutoffs, a Cutoff Hi of 99.5% is recommended to ensure valve goes fully open. The Hi Cutoff/Limit is deactivated by setting it to 125%.
- Hi Soft Cutoff Rate—This setting allows the valve to ramp to the high travel extreme when the Cutoff Point is reached at the configured rate. This provides a controlled ramp into the open travel stop. When set to 0%/second, the Hi Soft Cutoff rate is disabled.
- Lo Limit/Cutoff Select—When the Lo Cutoff/Limit Select is configured for Cutoff, the Travel Target is set to 23% when the Travel is below the Lo Cutoff Point. When the Hi Cutoff/Limit Select is configured for Limit, the Travel Target will not fall below the Lo Limit Point.
- Lo Limit/Cutoff Point—This is the point within the calibrated travel range below which the Limit or Cutoff is in effect. When using cutoffs, a Cutoff Lo of 0.5% is recommended to help ensure maximum shutoff seat loading. The Lo Limit/Cutoff is deactivated by setting it to 25%.
- Lo Soft Cutoff Rate—This setting allows the valve to ramp to the low travel extreme when the Cutoff Point is reached at the configured rate. This provides a controlled ramp into the seat in order to minimize seat damage. When set to 0%/second, the Lo Soft Cutoff rate is disabled.

## Pressure Control

- **Pressure Range High**—The high end of output pressure range. Enter the pressure that corresponds with 100% valve travel when Zero Power Condition is closed, or 0% valve travel when Zero Power Condition is open. This pressure must be greater than the Pressure Range Lo.
- **Pressure Range Lo**—The low end of the output pressure range. Enter the pressure that corresponds to 0% valve travel when Zero Power Condition is closed, or 100% valve travel when Zero Power Condition is open. This pressure must be less than the Pressure Range Hi.

## Pressure Fallback

---

### NOTE

Pressure Fallback is available for instrument level AD, PD, ODV.

---

- **Tvl Dev Press Fallback**—When the difference between the travel target and the actual travel exceeds this value for more than the Tvl Dev Press Fallback Time, the instrument will disregard the travel feedback and control based on output pressure.
- **Tvl Dev Press Fallback Time**—This is the time, in seconds, that the travel target and the actual travel must be exceeded before the instrument falls back into pressure control.
- **Fallback Recovery**—If the instrument has fallen into pressure control and the feedback problem is resolved, recovery to travel control can occur automatically or with manual intervention. To return to travel control when Manual Recovery is selected, change the Fallback Recovery to Auto Recovery, and then back to Manual Recovery (if desired).

## Control Mode

- **Control Mode**—This displays the current control mode of the instrument. This will show Analog if the instrument is in Point-to-Point mode and is using a 4 to 20 mA signal for its power and set point. This will show Digital if the instrument is in Multidrop mode and is using 24 V DC for power and a digital set point for control.
- 

### NOTE

Another mode, Test, may be displayed. Normally the instrument should not be in the Test mode. The digital valve controller automatically switches to this mode whenever it needs to stroke the valve during calibration or stroke valve, for example. However, if you abort from a procedure where the instrument is in the test mode, it may remain in this mode. To take the instrument out of the Test mode, select Change Control Mode and enter Analog or Digital.

---

- **Change Control Mode**—This allows the user to configure the control mode to Analog or Digital.
- **Restart Control Mode**—This defines the Control Mode of the instrument after a restart (e.g. power cycle). Available choices are Resume Last, Analog and Digital.

## Characterization

- Input Characterization

Input Characterization defines the relationship between the travel target and ranged set point. Ranged set point is the input to the characterization function. If the zero power condition equals closed, then a set point of 0% corresponds to a ranged input of 0%. If the zero power condition equals open, a set point of 0% corresponds to a ranged input of 100%. Travel target is the output from the characterization function.

To select an input characterization, select Input Characterization from the Characterization menu. You can select from the three fixed input characteristics shown in Figure 8 or you can select a custom characteristic. Figure 8 shows the relationship between the travel target and ranged set point for the fixed input characteristics, assuming the Zero Power Condition is configured as closed.

You can specify 21 points on a custom characteristic curve. Each point defines a travel target, in % of ranged travel, for a corresponding set point, in % of ranged set point. Set point values range from -6.25% to 106.25%. Before modification, the custom characteristic is linear.

- Custom Characterization

To define a custom input character, select Custom Characterization from the Characterization menu. Select the point you wish to define (1 to 21), then enter the desired set point value. Press Enter then enter the desired travel target for the corresponding set point. When finished, select point 0 to return to the Characterization menu.

With input characterization you can modify the overall characteristic of the valve and instrument combination. Selecting an equal percentage, quick opening, or custom (other than the default of linear) input characteristic modifies the overall valve and instrument characteristic. However, if you select the linear input characteristic, the overall valve and instrument characteristic is the characteristic of the valve, which is determined by the valve trim (i.e., the plug or cage).

**Figure 8. Travel Target Versus Ranged Set Point, for Various Input Characteristics (Zero Power Condition = Closed)**

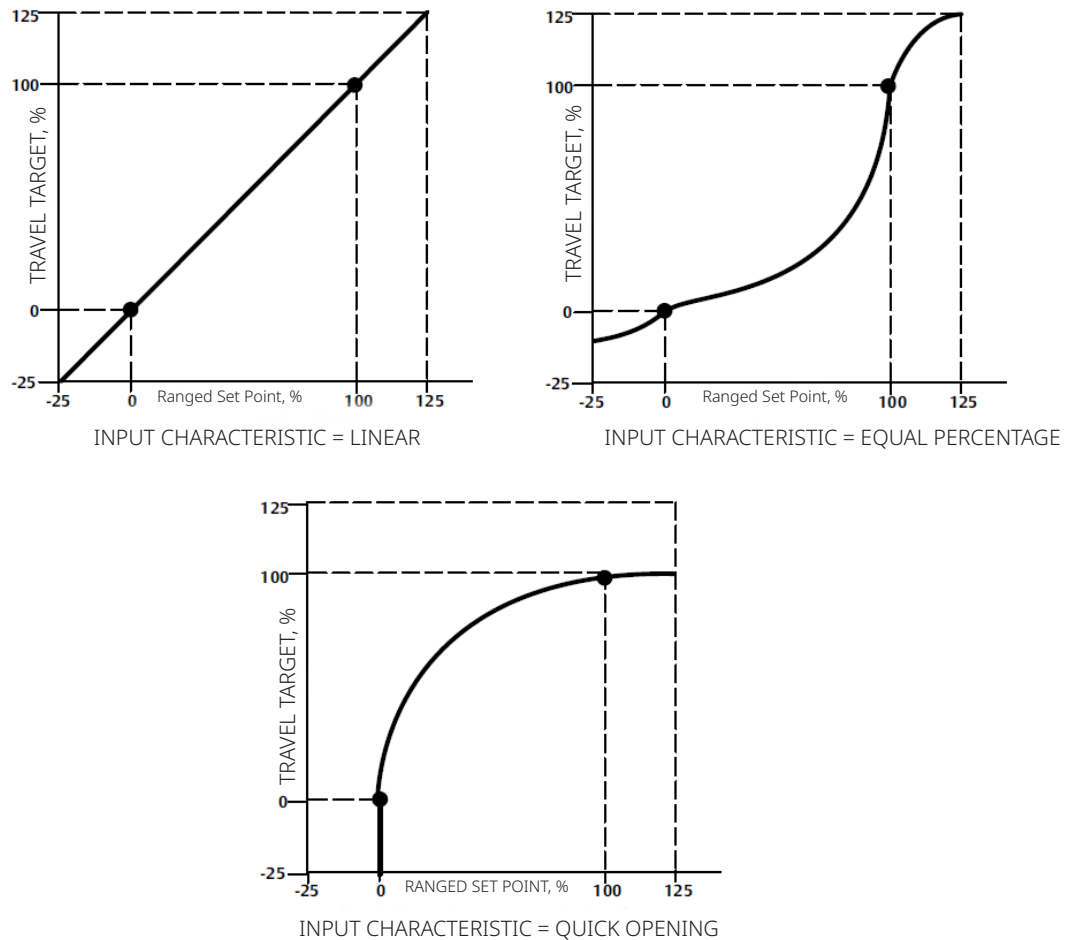

A6535-1

## Dynamic Response

- **SP Rate Open**—Maximum rate (% of valve travel per second) at which the digital valve controller will move to the open position regardless of the rate of input current change. A value of 0 will deactivate this feature and allow the valve to stroke open as fast as possible.
- **SP Rate Close**—Maximum rate (% of valve travel per second) at which the digital valve controller will move to the close position regardless of the rate of input current change. A value of 0 will deactivate this feature and allow the valve to stroke close as fast as possible.
- **Set Point Filter Time (Lag Time)**—The Set Point Filter Time (Lag Time) slows the response of the digital valve controller. A value ranging from 0.2 to 10.0 can be used for noisy or fast processes to improve closed loop process control. Entering a value of 0.0 will deactivate the lag filter.

**NOTE**

Set Point Filter Time (Lag Time) is available for instrument level HC, AD and PD.

- Lead/Lag Set Point Filter—ODV devices have access to a lead-lag set point filter that can be used to improve a valve's dynamic response. The lead-lag filter is part of the set point processing routine that reshapes the input signal before it becomes travel set point. Lead-lag filters are characterized by lead and lag time constants.

**NOTE**

Lead/Lag is only available for instrument level ODV.

When the valve is in its active control region (off the seat), the lead-lag filter improves small amplitude response by momentarily overdriving the travel set point. This is useful when the actuator is large and equipped with accessories. As a result, any volume boosters that are present will be activated. The longer the lag time, the more pronounced the overdrive. Since the lead-lag input filter is used to enhance the dynamic response of a control valve, filter parameters should be set after the tuning parameters have been established.

When the valve is at its seat, the lead-lag filter also has a boost function that sets the initial conditions of the filter artificially low so that small amplitude signal changes appear to be large signal changes to the filter. The boost function introduces a large spike that momentarily overdrives the instrument and activates any external volume boosters that may be present. The lead-lag boost function is normally disabled except for those cases where the valve must respond to small command signals off the seat. By setting the lead/lag ratio in the opening and closing directions to 1.0, the boost function can be enabled without introducing lead-lag dynamics in the active control region. See Table 6 for typical lead-lag filter settings.

**Table 6. Typical Lead/Lag Filter Settings for Instrument Level ODV**

Parameter	Description	Typical Value
Lag Time	First order time constant. A value of 0.0 will disable the lead-lag filter.	0.2 second
Opening Lead/Lag Ratio	Initial response to the filter in the opening direction.	2.0
Closing Lead/Lag Ratio	Initial response to the filter in the closing direction.	2.0
Lead-Lag Boost	Initial conditions of the lead-lag filter when the lower travel cutoff is active.	Off

## 3.5 Tuning

Handheld Communicator

Configure > Manual Setup > Tuning

### Travel Tuning

#### **⚠ WARNING**

**Changes to the tuning set may cause the valve/actuator assembly to stroke. To avoid personal injury and property damage caused by moving parts, keep hands, tools and other objects away from the valve/actuator assembly.**

- Travel Tuning Set

There are eleven tuning sets to choose from. Each tuning set provides a preselected value for the digital valve controller gain settings. Tuning set C provides the slowest response and M provides the fastest response.

Table 7 lists the proportional gain, velocity gain and minor loop feedback gain values for preselected tuning sets.

**Table 7. Gain Values for Preselected Travel Tuning Sets**

Tuning Set	Proportional Gain	Velocity Gain	Minor Loop Feedback Gain
C	4.4	3.0	35
D	4.8	3.0	35
E	5.5	3.0	35
F	6.2	3.1	35
G	7.2	3.6	34
H	8.4	4.2	31
I	9.7	4.85	27
J	11.3	5.65	23
K	13.1	6.0	18
L	15.5	6.0	12
M	18.0	6.0	12
X (Expert)	User Adjusted	User Adjusted	User Adjusted

In addition, you can specify Expert tuning and individually set the proportional gain, velocity gain, and minor loop feedback gain. Individually setting or changing any tuning parameter or running Stabilize/Optimize will automatically change the tuning set to X (expert).

#### **NOTE**

Use Expert tuning only if standard tuning has not achieved the desired results.

Stabilize/Optimize or Performance Tuner in ValveLink software, may be used to achieve the desired results more rapidly than manual Expert tuning.

Table 8 provides tuning set selection guidelines for Fisher and Baumann actuators. These tuning sets are only recommended starting points. After you finish setting up and calibrating the instrument, you may have to select either a higher or lower tuning set to get the desired response.

**Table 8. Actuator Information for Initial Setup**

Actuator Manufacturer	Actuator Model	Actuator Size	Actuator Style	Starting Tuning Set	Travel Sensor Motion <sup>(2)</sup> Relay A or C <sup>(3)</sup>	
Fisher	585C and 585CR	25 50 60 68, 80 100, 130	Piston Dbl with or without Spring. See actuator instruction manual and nameplate.	E I J L M	User Specified	
	657	30, 30i 34, 34i, 40, 40i 45, 45i, 50, 50i 46, 46i, 60, 60i, 70, 70i and 80 to 100	Spring and Diaphragm	H K L M	Away from the top of the instrument	
	667	30, 30i 34, 34i, 40, 40i 45, 45i, 50, 50i 46, 46i, 60, 60i, 70, 70i, 76, 76i and 80 to 100	Spring and Diaphragm	H K L M	Towards the top of the instrument	
	1051 and 1052	20, 30 33 40 60, 70	Spring and Diaphragm (Window-mount)	H I K M	Away from the top of the instrument	
	1061	30 40 60 68, 80, 100, 130	Piston Dbl without Spring	J K L M	Depends upon pneumatic connections. See description for Travel Sensor Motion.	
	1066SR	20 27, 75	Piston Sgl with Spring	G L	<b>Mounting Style</b>	<b>Travel Sensor Motion</b>
				A	Away from the top of the instrument	
				B	Towards the top of the instrument	
				C	Towards the top of the instrument	
				D	Away from the top of the instrument	

- continued -

**Table 8. Actuator Information for Initial Setup (continued)**

Actuator Manufacturer	Actuator Model	Actuator Size	Actuator Style	Starting Tuning Set	Travel Sensor Motion <sup>(2)</sup> Relay A or C <sup>(3)</sup>	
Fisher	2052	1	Spring and Diaphragm (Window-mount)	H	Away from the top of the instrument	
		2		J		
		3		M		
	3024C	30, 30E 34, 34E, 40, 40E 45, 45E	Spring and Diaphragm	E	For P <sub>O</sub> operating mode (air opens): Towards the top of the instrument For P <sub>S</sub> operating mode (air closes): Away from the top of the instrument	
				H		
				K		
GX	225 750 1200	Spring and Diaphragm	X <sup>(1)</sup>	Air to Open Towards the top of the instrument	Air to Close Away from the top of the instrument	
			K			
			M			
Baumann	Air to Extend	16	Spring and Diaphragm	C	Away from the top of the instrument	
		32		E		
	Air to Retract	54		H	Towards the top of the instrument	
		10		E		
	Rotary	25		H	Specify	
		54		J		

NOTE: Refer to Table 10 for feedback connection (magnet assembly) information.

1. X = Expert Tuning. Proportional Gain = 4.2; Velocity Gain = 3.0; Minor Loop Feedback Gain = 18.0
2. Travel Sensor Motion in this instance refers to the motion of the magnet assembly.
3. Values shown are for Relay A and C. Reverse for Relay B.

- Proportional Gain—the proportional gain for the travel control tuning set. Changing this parameter will also change the tuning set to Expert.
- Velocity Gain—the velocity gain for the travel control tuning set. Changing this parameter will also change the tuning set to Expert.
- MLFB Gain—the minor loop feedback gain for the travel control tuning set. Changing this parameter will also change the tuning set to Expert.
- Integral Enable—Yes or No. Enable the integral setting to improve static performance by correcting for error that exists between the travel target and actual travel. Travel Integral Control is enabled by default.
- Integral Gain—Travel Integral Gain is the ratio of the change in output to the change in input, based on the control action in which the output is proportional to the time integral of the input.



- Stabilize/Optimize

**⚠ WARNING**

**During Stabilize/Optimize the valve may move, causing process fluid or pressure to be released. To avoid personal injury and property damage caused by the release of process fluid or pressure, isolate the valve from the process and equalize pressure on both sides of the valve or bleed off the process fluid.**

Stabilize/Optimize permits you to adjust valve response by changing the digital valve controller tuning. During this routine, the instrument must be out of service, however, the instrument will respond to setpoint changes.

If the valve is unstable, select decrease response for a more conservative setting. If the valve response is sluggish, select increase response for a more aggressive setting. When finished, select Done.

### Pressure Tuning

- Pressure Tuning Set

There are twelve Pressure Tuning Sets to choose from. Each tuning set provides a preselected value for the digital valve controller gain settings. Tuning set C provides the slowest response and M provides the fastest response.

Tuning set B is appropriate for controlling a pneumatic positioner. Table 9 lists the proportional gain, pressure integrator gain and minor loop feedback gain values for preselected tuning sets.

**Table 9. Gain Values for Preselected Pressure Tuning Sets**

Tuning Set	Proportional Gain	Integrator Gain	Minor Loop Feedback Gain
B	0.5	0.3	35
C	2.2	0.1	35
D	2.4	0.1	35
E	2.8	0.1	35
F	3.1	0.1	35
G	3.6	0.1	34
H	4.2	0.1	31
I	4.8	0.1	27
J	5.6	0.1	23
K	6.6	0.1	18
L	7.8	0.1	12
M	9.0	0.1	12
X (Expert)	User Adjusted	User Adjusted	User Adjusted

In addition, you can specify Expert tuning and individually set the pressure proportional gain, pressure integrator gain and pressure minor loop feedback gain. Individually setting or changing any tuning parameter will automatically change the tuning set to X (expert).

**NOTE**

Use Expert tuning only if standard tuning has not achieved the desired results.

Stabilize/Optimize, or Performance Tuner in ValveLink software, may be used to achieve the desired results more rapidly than Expert tuning.

- Proportional Gain—the proportional gain for the pressure control tuning set. Changing this parameter will also change the tuning set to Expert.
- MLFB Gain—the minor loop feedback gain for the pressure control tuning set. Changing this parameter will also change the tuning set to Expert.
- Integral Enable—Yes or No. Enable the pressure integral setting to improve static performance by correcting for error that exists between the pressure target and actual pressure. Pressure Integral Control is enabled by default.
- Integral Gain—Pressure Integral Gain (also called reset) is the gain factor applied to the time integral of the error signal between desired and actual pressure. This feature is used during pressure control for greater accuracy during pressure control/fallback. Changing this parameter will also change the tuning set to Expert.

## Travel/Pressure Integral Settings

- Integral Dead Zone—A window around the Primary Setpoint in which integral action is disabled. The Dead Zone is configurable from 0% to 2%, corresponding to a symmetric window from 0% to +/-2% around the Primary Setpoint. Integral Dead Zone is used to eliminate friction induced limit cycles around the Primary Setpoint when the integrator is active. This dead zone value is used during the Auto Calibration of Travel procedure even if the travel integral is disabled; in the case of Auto Calibration travel failures with piston actuators, this value should be set to 1%. Default value is 0.26%.
- Integrator Limit—The Integrator Limit provides an upper limit to the integrator output. The high limit is configurable from 0 to 100% of the I/P drive signal.

## 3.6 Valve and Actuator

**Handheld Communicator**

Configure &gt; Manual Setup &gt; Valve and Actuator

Valve Style—Enter the valve style, rotary or sliding-stem.

Actuator Style—Enter the actuator style, spring and diaphragm, piston double-acting without spring, piston single-acting with spring or piston double-acting with spring.

Feedback Connection—Refer to Table 10 for Feedback Connection options. Choose the assembly that matches the actuator travel range.

**NOTE**

As a general rule, do not use less than 60% of the magnet assembly travel range for full travel measurement. Performance will decrease as the assembly is increasingly subranged.

The linear magnet assemblies have a valid travel range indicated by arrows molded into the piece. This means that the hall sensor (on the back of the DVC6200 housing) has to remain within this range throughout the entire valve travel. The linear magnet assemblies are symmetrical. Either end may be up.

**Table 10. Feedback Connection Options**

Magnet Assembly	Travel Range		
	mm	in.	Degrees
SStem #7	4.2 to 7	0.17 to 0.28	---
SStem #19	8 to 19	0.32 to 0.75	---
SStem #25	20 to 25	0.76 to 1.00	---
SStem #38	26 to 38	1.01 to 1.50	---
SStem #50	39 to 50	1.51 to 2.00	---
SStem #110	51 to 110	2.01 to 4.125	---
SStem #210	110 to 210	4.125 to 8.25	---
SStem #1 Roller	> 210	> 8.25	60 to 90°
RShaft Window #1	---	---	60 to 90°
RShaft Window #2	---	---	60 to 90°
RShaft End Mount	---	---	60 to 90°

Relay Type—There are three categories of relays that result in combinations from which to select.

Relay Type: The relay type is printed on the label affixed to the relay body.

A = double-acting or single-acting

B = single-acting, reverse

C = single-acting, direct

Special App: This is used in single-acting applications where the “unused” output port is configured to read the pressure downstream of a solenoid valve.

Lo Bleed: The label affixed to the relay body indicates whether it is a low bleed version.

Zero Power Condition—The position of the valve (open or closed) when the electrical power to the instrument is removed. Zero Power Condition (ZPC) is determined by relay type, as shown in Figure 9.

**Figure 9. Zero Power Condition**



Relay Type	Loss of Electrical Power
Single-Acting Direct (Relay A or C)	Port A pressure to zero.
Single-Acting Reverse (Relay B)	Port A pressure to zero. Port B pressure to full supply.
Double-Acting (Relay A)	Port B pressure to full supply.

### Travel Sensor Motion

#### **⚠ WARNING**

**If you answer YES to the prompt for permission to move the valve when determining travel sensor motion, the instrument will move the valve through a significant portion of its travel range. To avoid personal injury and property damage caused by the release of process fluid or pressure, isolate the valve from the process and equalize pressure on both sides of the valve or bleed off the process fluid.**

Select Clockwise/Toward Bottom, or Counterclockwise/Toward Top. Travel Sensor Motion establishes the proper travel sensor rotation. For quarter-turn actuators determine rotation by viewing the rotation of the magnet assembly from the back of the instrument.

#### **NOTE**

Travel Sensor Motion in this instance refers to the motion of the magnet assembly. Note that the magnet assembly may be referred to as a magnetic array in user interface tools.

- For instruments with Relay A and C: If increasing air pressure at output A causes the magnet assembly to move down or the rotary shaft to turn clockwise, enter CW/To Bottom Inst. If it causes the magnet assembly to move up, or the rotary shaft to turn counterclockwise, enter CCW/To Top Inst.
- For instruments with Relay B: If decreasing air pressure at output B causes the magnet assembly to down, or the rotary shaft to turn clockwise, enter CW/To Bottom Inst. If it causes the magnet assembly to move up, or the rotary shaft to turn counterclockwise, enter CCW/To Top Inst.

### Maximum Supply Pressure

Enter the maximum supply pressure that is required to fully stroke the valve.

## Port A Pressure Limit

In single-acting direct only applications, the instrument will limit the output pressure to the actuator from Port A. When this pressure limit is exceeded the device will go to the no air state.

---

### NOTE

This is a firmware controlled feature that requires loop power to the instrument. If loop power is lost, or there is an electronic or firmware failure, the protection feature will not remain in effect.

---

## Output Pressure Limit

Output Pressure Limit Enable enables/disables the Port A Pressure Limit feature.

---

### NOTE

There is an associated alert available with this feature. See the Port A Overpressurized alert in the Alert Setup section.

---

## 3.7 Partial Stroke Test (PST)

**Handheld Communicator**

Configure > Manual Setup > Partial Stroke

---

### NOTE

Partial Stroke is only available for instrument level ODV.

---

## Partial Stroke Test Parameters

Test Start Point defines the normal (not tripped) end of valve travel. The valve must be at this end for a PST to be initiated. Setting this value to Not Configured will disable partial stroke tests.

Travel Hi Hi defines, in percent (%) of calibrated travel, the point above which the valve is considered to have reached the high end.

Travel Lo Lo defines, in percent (%) of calibrated travel, the point below which the valve is considered to have reached the low end.

Pause Time is the time between the outgoing and incoming strokes of the test. The default value is 5 seconds. Pause Time will not be used if Short Duration PST is enabled. The outgoing stroke is from the normal end to the PST target and the incoming stroke is the return stroke to normal. See Figure 10.

Figure 10. Valve Signature Representation

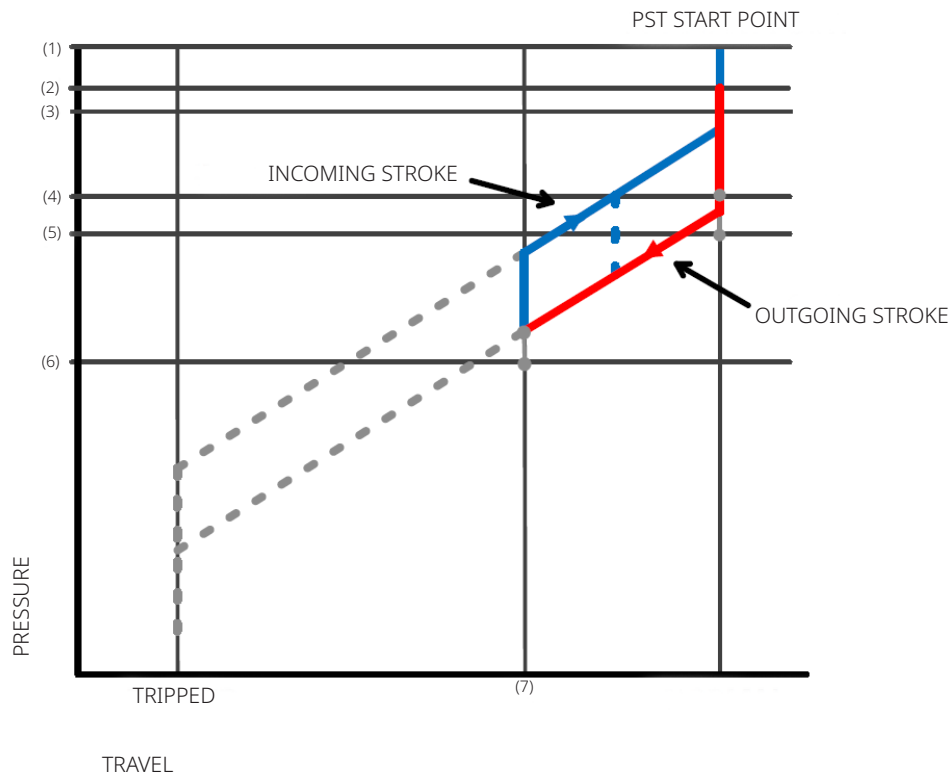

1. SUPPLY PRESSURE
2. END POINT PRESSURE CONTROL
3. INCOMING PRESSURE THRESHOLD
4. LOW FRICTION BREAKOUT PRESSURE THRESHOLD
5. HIGH FRICTION BREAKOUT PRESSURE THRESHOLD
6. OUTGOING PRESSURE THRESHOLD
7. TARGET TRAVEL MOVEMENT  $\leq 30\%$

High Friction Breakout Pressure indicates that the breakout required a higher force than configured by the user. Refer to Figure 10.

Low Friction Breakout Pressure indicates that the breakout required a lower force than configured by the user. Refer to Figure 10.

Action On a Failed Test defines if the valve should step or ramp back on a failed stroke test.

Auto Test Interval is the interval of time in days between valve stroke tests that are automatically executed by the digital valve controller, subject to the device being powered up. A value of 0 disables this feature.

## Partial Stroke Parameters

Minimum Travel Movement is the percentage of total span that the valve moves away from its normal operating end of travel towards its tripped end of travel during the test. The default value is 10%.

Short Duration PST, when enabled the incoming stroke is initiated as soon as the travel reaches the minimum travel movement. Refer to Figure 11 for a time series representation of this parameter.

**Figure 11. Time Series Representation of Short Duration PST**

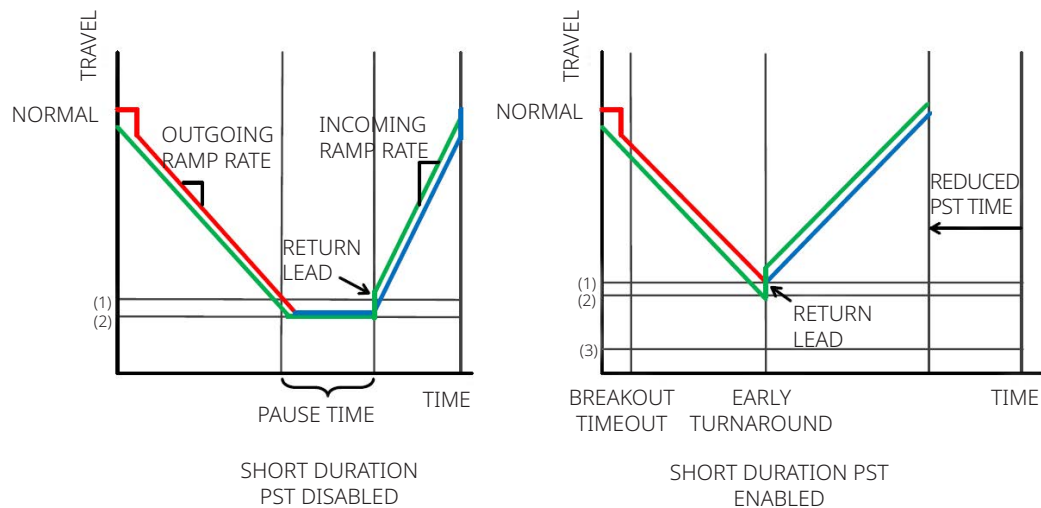

1. MINIMUM TRAVEL MOVEMENT
2. TRAVEL TARGET MOVEMENT
3. MAX. ALLOWABLE TRAVEL

Outgoing Ramp Rate is the rate at which the valve will move during the Outgoing stroke of the Partial Stroke test. The default value is 0.25%/second.

Incoming Ramp Rate is the rate at which the valve will move during the Incoming stroke of the Partial Stroke test. The default value is 0.25%/second.

Return Lead defines the percent (%) change in setpoint to overcome the hysteresis in the valve assembly. The error between setpoint and actual error is added to this percent change. For example, if the Return Lead is set at 0.5% and there is a 1% error this will be set at 1.5%.

Breakout Timeout is the user configured amount of time before which the valve must leave the normal end during a PST.

Outgoing Pressure Threshold defines the actuator pressure at which a partial stroke test will abort during the outgoing stroke (see Figure 10). This prevents the DVC6200 from exhausting (or building) excessive pressure from/to the actuator in an attempt to move a stuck valve. During PST Calibration, the Partial Stroke Outgoing Pressure Threshold will be set automatically as follows:

- Single-Acting Actuators - For those actuators that exhaust pressure from the partial test start point, the Outgoing Pressure Threshold will be a minimum value. For those actuators that build pressure from the partial test start point, the Outgoing Pressure Threshold will be a maximum value.
- Double-Acting Actuators - The Outgoing Pressure Threshold will be set to a negative value for actuators where the partial stroke start point is opposite of the Zero Power Condition (e.g., Partial Stroke Start Point = Open and Zero Power Condition = Closed) and to a positive value for actuators where the partial stroke start point is the same as the Zero Power Condition.

The pressure signal used to determine this parameter depends on relay type and is summarized below.

Relay Type	Pressure Signal
A or C	Port A - Port B
B	Port B - Port A
B Special App.	Port B
C Special App.	Port A

To manually set the partial stroke Outgoing Pressure Threshold, you must examine current partial stroke test results using ValveLink software. The following steps will guide you through the process:

1. Connect the DVC6200 to a system running ValveLink software.
2. Disable Partial Stroke Outgoing Pressure Limit by ensuring it is not selected as an evaluation criteria for PST Abnormal.
3. Run a partial stroke test.
4. Select the Press/Time radio button on the partial stroke graph (refer to the example in Figure 12). If the actuator pressure starts high and moves low, find the minimum actuator pressure ( $P_{MIN}$ ). If the actuator pressure starts low and moves high, find the maximum actuator pressure ( $P_{MAX}$ ). Double-acting actuators will display differential pressure. Use Table 11 to estimate the Outgoing Pressure Threshold.
5. Enable the previously disabled Outgoing Pressure Limit - calculate the value using Table 11.



**Table 11. Estimates for Outgoing Partial Stroke Pressure Limits**

Actuator Style	Relay Type	Zero Power Condition	PST Starting Point	Partial Stroke Pressure Limit
Spring and Diaphragm	A or C	Closed	Open	$P_{min} - 0.25 * (\text{Bench Set High} - \text{Bench Set Low})$
			Closed	$P_{max} + 0.25 * (\text{Bench Set High} - \text{Bench Set Low})$
		Open	Open	$P_{max} + 0.25 * (\text{Bench Set High} - \text{Bench Set Low})$
			Closed	$P_{min} - 0.25 * (\text{Bench Set High} - \text{Bench Set Low})$
	B	Closed	Open	$P_{max} + 0.25 * (\text{Bench Set High} - \text{Bench Set Low})$
			Closed	$P_{min} - 0.25 * (\text{Bench Set High} - \text{Bench Set Low})$
		Open	Open	$P_{min} - 0.25 * (\text{Bench Set High} - \text{Bench Set Low})$
			Closed	$P_{max} + 0.25 * (\text{Bench Set High} - \text{Bench Set Low})$
Single-Acting Piston	A or C	Closed	Open	$0.5 * P_{min}$
			Closed	$P_{max} + 0.5 * (P_{supply} - P_{max})$
		Open	Open	$P_{max} + 0.5 * (P_{supply} - P_{max})$
			Closed	$0.5 * P_{min}$
	B	Closed	Open	$P_{max} + 0.5 * (P_{supply} - P_{max})$
			Closed	$0.5 * P_{min}$
		Open	Open	$0.5 * P_{min}$
			Closed	$P_{max} + 0.5 * (P_{supply} - P_{max})$
Double-Acting Piston	A	Closed	Open	$P_{min} - 0.5 * (P_{supply} + P_{min})$
			Closed	$P_{max} + 0.5 * (P_{supply} - P_{max})$
		Open	Open	$P_{max} + 0.5 * (P_{supply} - P_{max})$
			Closed	$P_{min} - 0.5 * (P_{supply} + P_{min})$

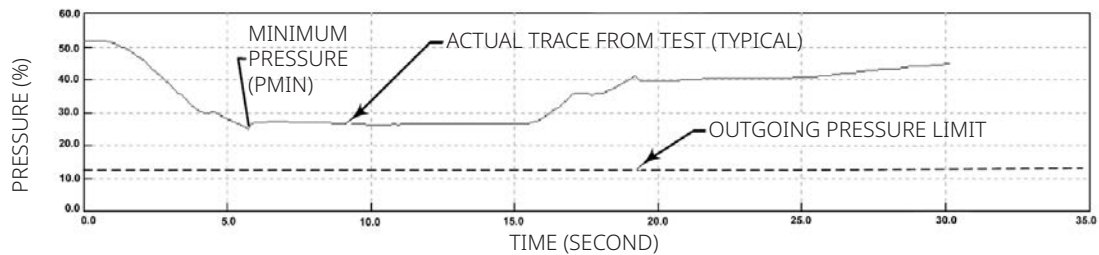
**Figure 12. Example Time Series Plot; Actuator Pressure**

Incoming Pressure Threshold defines the actuator pressure at which a partial stroke test will abort during the incoming stroke (see Figure 10). This prevents the DVC6200 from exhausting (or building) excessive pressure from/to the actuator in an attempt to move a stuck valve.

### PST Abnormal Criteria

A partial stroke test is marked as abnormal if it fails any of the following user-selected criteria.

1. Stroking Pressure (includes outgoing and incoming)
2. Hi friction breakout pressure
3. Low friction breakout pressure
4. Max travel
5. Insufficient travel
6. Not seated (either at the start or end of the test)
7. SOV Test preceded PST and failed
8. Travel deviation

### PST Abort Criteria

The PST is terminated and the valve is returned to the normal end. The return to the normal end will be per the user configuration for an aborted test. The abort criteria will only be active if it is added as a criteria to be evaluated during PST by adding it to the PST Abnormal Criteria.

The user can select any of the following to abort a Partial Stroke Test:

1. Stroking Pressure (includes outgoing and incoming)
2. Hi friction breakout pressure
3. Low friction breakout pressure
4. Max travel
5. Insufficient travel
6. Not seated (either at the start or end of the test)
7. SOV Test preceded PST and failed
8. Travel deviation

## PST Prohibited

A partial stroke test will not be initiated if any of the following user-configurable conditions are active:

1. Flash Integrity Failure
2. Minor Loop Sensor Failure
3. Reference Voltage Failure
4. Drive Current Failure
5. Critical NVM Failure
6. Temperature Sensor Failure
7. Pressure Sensor Failure
8. Travel Sensor Failure
9. Supply Pressure Low
10. Travel Deviation
11. Pressure Fallback active

## 3.8 Outputs

**Handheld Communicator**

Configure &gt; Manual Setup &gt; Outputs

### Output Terminal Configuration

**NOTE**

These menu items are only available on units that have the optional 4 to 20 mA position transmitter or switch hardware installed. For information on position transmitter/discrete switch wiring and configuration refer to the DVC6200 Series quick start guide, [D103556X012](#).

- Output Terminal Enable—If using the optional output terminal for a Position Transmitter or Switch output, this must be enabled with a user interface tool such as ValveLink software.
- Function—The output terminals can be configured as one of the following:
  - Transmitter - 4 to 20 mA output that represents 0 to 100% of the calibrated valve travel.
  - Limit Switch - Discrete switch (1 A max) that trips at a configurable point within 0 to 100% of calibrated valve travel.
  - Alert Switch - Discrete switch (1 A max) that trips based on a configurable device alert.
- Fail Signal—Should the output circuit fail to operate properly, the output will attempt to drive to a known state. Depending on the nature of the failure, the circuit may or may not be able to achieve this fail state. When configured as a position transmitter, the output can be configured to fail low (< 3.6 mA). The output can be configured to fail high (> 22.5 mA) when the digital valve controller is powered. When configured as a switch, the output can be configured to drive Closed or Open.

**NOTE**

On loss of digital valve controller power, the switch circuit will always go to the open state.

## Switch Configuration

**NOTE**

Switch Configuration is only available on units that have the optional 4 to 20 mA position transmitter or switch hardware installed.

- Limit Switch Trip Point—When the function is configured as a Limit Switch, this defines the threshold for the limit switch in percent of calibrated travel.
- Alert Switch Source—When the function is configured as a Alert Switch, this determines which alert will activate the switch. The alert choices are: Travel Deviation or Pressure Fallback.
- Switch Closed—This configures the action of the switch. The choices are: Below Trip Point/Alert Not Active or Above Trip Point/Alert Active.

## HART Variable Assignments

Instrument variables can be reported via four different HART variable assignments. The Primary Variable is always configured as Analog Input. However, the remaining three variables have additional options as listed below.

Primary Variable (PV)	Analog Input
Secondary Variable (SV)	Travel, Travel Setpoint, Pressure A, Pressure B, Pressure AB, Supply Pressure, Drive Signal or Analog Input
Tertiary Variable (TV)	Travel, Travel Setpoint, Pressure A, Pressure B, Pressure AB, Supply Pressure, Drive Signal or Analog Input
Quaternary Variable (QV)	Travel, Travel Setpoint, Pressure A, Pressure B, Pressure AB, Supply Pressure, Drive Signal or Analog Input

## Transmitter Output

**NOTE**

Transmitter Output is only available on units that have the optional 4 to 20 mA position transmitter or switch hardware installed.

This configures the relationship between the valve travel and the position transmitter output signal. There are two choices; 4 mA = Valve Closed or 4 mA = Valve Open.

## Burst Mode

Burst mode provides continuous communication from the digital valve controller. Burst mode applies only to the transmission of burst mode data (HART Variable Assignments) and does not affect the way other data is accessed.

- Burst Enable—This turns on or off the burst mode.
- Burst Command—This defines which HART command is configured for burst reporting. When using a TriLoop, select Command 3.

HART 5

- Analog Input (Command 1)
- Loop Current / Travel (Command 2)
- Loop Current / PV / SV / TV / QV (Command 3)

HART 7

- Analog Input (Command 1)
- Loop Current / Travel (Command 2)
- Loop Current / PV / SV / TV / QV (Command 3)
- Read Device Variable with Status (Command 9)
- Read Device Variables (Command 33)
- Read Additional Status (Command 48)

---

### NOTE

Access to information in the instrument is normally obtained through the poll/response of HART communication. The handheld communicator or the control system may request any of the information that is normally available, even while the instrument is in burst mode. Between each burst mode transmission sent by the instrument, a short pause allows the handheld communicator or control system to initiate a request. The instrument receives the request, processes the response message and then continues “bursting” the burst mode data.

Burst mode will be automatically disabled during diagnostics tests such as Valve Signature.

HART 7 allows three burst commands to be reported. When using a Tri-Loop, do not enable the 2nd or 3rd burst commands. These additional commands will result in missed messages, thus taking the Tri-Loop's output to the fault state.

---

### NOTE

If the instrument is configured to operate in pressure control mode, or detects an invalid travel sensor reading, the Travel variable will report pressure in percent of bench set range.

---

## 3.9 Alert Setup

**Handheld Communicator**

Configure > Alert Setup

An alert is a notification that the instrument has detected a problem. Alerts that are enabled and active will be recorded in the instrument memory within the Alert Record (see Section 5). Some alerts are also defined in the HART Command 48 response structure which is can be read by any HART communicating host system (refer to the HART Field Device Specification, [D103639X012](#)).

Certain critical alerts can be configured to shut down the device when active (i.e., latch in the Zero Power Condition). This can be enabled or disabled for each applicable alert. The default shutdown setting is disabled. To clear the shutdown, correct the problem and then cycle power to the instrument (or disable the alert).

Alerts may be enabled or disabled with the instrument In Service, Out of Service, Protection On or Protection Off. However, shutdown alerts can only be enabled or disabled while Protection is off.

For a detailed explanation of the alerts and the recommended actions, refer to Section 5.

## 3.10 Change to HART 5 / Change to HART 7

**Handheld Communicator** Service Tool > Maintenance > Change to HART 5 / Change to HART 7

### NOTE

This procedure must never be done while the valve is in service and controlling the process. Depending on the control system or asset management system attached, complete system reset may be required to reestablish HART communication. Consult the system documentation for further information.

This procedure changes the instrument from HART Universal Revision 5 to HART Universal Revision 7 (or vice versa). Before proceeding, verify that your systems are prepared to support HART Universal Revision 7 devices. Follow the prompts on the handheld communicator display.

## Section 4: Calibration

### Calibration Overview

When a DVC6200 digital valve controller is ordered as part of a control valve assembly, the factory mounts the digital valve controller on the actuator and connects the necessary tubing, then sets up and calibrates the controller.

For digital valve controllers that are ordered separately, recalibration of the analog input or pressure sensors generally is unnecessary. However, after mounting on an actuator, perform the initial setup then calibrate travel by selecting *Configure > Calibration > Travel Calibration > Auto Calibration*. For more detailed calibration information, refer to the following calibration procedures.

**NOTE**

The Instrument Mode must be Out Of Service and the Protection set to None before the instrument can be calibrated.

If you are operating in burst mode, we recommend that you disable burst before continuing with calibration. Once calibration is complete, burst mode may then be turned back on.

**⚠ WARNING**

**During calibration, the valve will move full stroke. To avoid personal injury and property damage caused by the release of pressure or process fluid, isolate the valve from the process and equalize pressure on both sides of the valve or bleed off the process fluid.**

**Handheld Communicator**

Configure &gt; Calibration

## 4.1 Travel Calibration

If a double-acting relay is used, you will be prompted to run the relay adjustment when auto or manual calibration is selected. Select Yes to adjust the relay, select No to proceed with calibration. For additional information, refer to Relay Adjustment on page 51.

### Auto Calibration

1. The auto calibration procedure is automatic. It is completed when the Calibration menu appears.  
During calibration, the instrument seeks the high and low end points and the minor loop feedback (MLFB) and output bias. By searching for the end points, the instrument establishes the limits of physical travel, i.e., the actual travel 0 and 100% positions. This also determines how far the relay beam swings to calibrate the sensitivity of the MLFB sensor.
2. Place the instrument In Service and verify that the travel properly tracks the current source.  
If the unit does not calibrate, refer to Table 12 for error messages and possible remedies.

**Table 12. Auto Calibrate Travel Error Messages**

Error Message	Possible Problem and Remedy
Power failure occurred during Auto Calib.	The analog input signal to the instrument must be greater than 3.8 mA. Adjust the current output from the control system or the current source to provide at least 4.0 mA.
Auto Calib did not complete within the time limit.	The problem may be one or the other of the following: 1. The tuning set selected is too low and the valve does not reach an end point in the allotted time. Select Manual Setup > Tuning > Travel Tuning > Stabilize/Optimize then Increase Response (selects next higher tuning set). 2. The tuning set selected is too high, valve operation is unstable and does not stay at an end point for the allotted time. Select Manual Setup > Tuning > Travel Tuning > Stabilize/Optimize then Decrease Response (selects next lower tuning set).
Insufficient travel	Prior to receiving this message, did the instrument output go from zero to full supply? If not, verify instrument supply pressure by referring to the specifications in the appropriate actuator instruction manual. If supply pressure is correct, check instrument pneumatic components (I/P converter and relay). If the instrument output did go from zero to full supply prior to receiving this message, then verify proper mounting by referring to the appropriate mounting procedure in the Installation section and checking the magnet array for proper alignment.
Drive signal exceed low limit; check supply pressure	1. Check supply pressure (reverse-acting relay) 2. Friction is too high.
Drive signal exceed high limit; check supply pressure	1. Check supply pressure (direct-acting relay) 2. Friction is too high.

## Manual Calibration

Two procedures are available to manually calibrate travel:

- Analog Adjust— This procedure is used when you can manually change the 4 to 20 mA current source to move the valve.
- Digital Adjust— This procedure is used when the 4 to 20 mA current source cannot be manually changed.

### Analog Calibration Adjust

Connect a variable current source to the instrument LOOP + and LOOP - terminals. The current source should be capable of generating 4 to 20 mA.

Follow the prompts on the handheld communicator display to calibrate the instrument's travel in percent.



---

**NOTE**

0% Travel = Valve Closed  
100% Travel = Valve Open

---

1. Adjust the input current until the valve is near mid-travel. Press OK.
- 

**NOTE**

In steps 2 through 7, the accuracy of the current source adjustment affects the position accuracy.

---

2. Adjust the current source until the valve is at 0% travel, then press OK.
3. Adjust the current source until the valve is at 100% travel, then press OK.
4. Adjust the current source until the valve is at 0% travel, then press OK.
5. Adjust the current source until the valve is at 100% travel, then press OK.
6. Adjust the current source until the valve is at 5% travel, then press OK.
7. Adjust the current source until the valve is at 95% travel, then press OK.
8. Place the instrument In Service and verify that the travel properly tracks the current source.

## Digital Calibration Adjust

Connect a variable current source to the instrument LOOP + and LOOP - terminals. The current source should be set between 4 and 20 mA.

Follow the prompts on the handheld communicator display to calibrate the instrument's travel in percent.

1. Adjust the input current until the valve is near mid-travel. Press OK.
- 

**NOTE**

0% Travel = Valve Closed  
100% Travel = Valve Open

---

2. From the adjustment menu, select the direction and size of change required to set the travel at 0%.

Selecting large, medium, and small adjustments causes changes of approximately 10.0%, 1.0% and 0.1%, respectively. If another adjustment is required, repeat step 2. Otherwise, select Done and go to step 3.

3. From the adjustment menu, select the direction and size of change required to set the travel to 100%.

If another adjustment is required, repeat step 3. Otherwise, select Done and go to step 4.

4. From the adjustment menu, select the direction and size of change required to set the travel at 0%.

If another adjustment is required, repeat step 4. Otherwise, select Done and go to step 5.

5. From the adjustment menu, select the direction and size of change required to set the travel to 100%.

If another adjustment is required, repeat step 5. Otherwise, select Done and go to step 6.

6. From the adjustment menu, select the direction and size of change required to set the travel to 5%.

If another adjustment is required, repeat step 6. Otherwise, select Done and go to step 7.

7. From the adjustment menu, select the direction and size of change required to set the travel to 95%.

If another adjustment is required, repeat step 7. Otherwise, select Done and go to step 8.

8. Place the instrument In Service and verify that the travel properly tracks the current source.

## Pushbutton Calibration

### Pushbutton Calibration

A pushbutton near the wiring terminals in the terminal box provides a quick means to autocalibrate the instrument. The button must be pressed for 3 to 10 seconds. Autocalibration will move the valve through the full range of travel whether the Instrument Mode is In Service or Out of Service. However, if the Write Protection is Protected, this button will not be active. To abort, press the button again for 1 second. The calibration button is enabled by default. To disable it, go to Manual Setup > Instrument > Calibration Button.

---

#### NOTE

Pressure range (used for Pressure Fallback) is not recalibrated during this procedure.

---

This calibration procedure is recommended whenever the I/P converter or pneumatic relay is replaced. Do not use the pushbutton calibration for initial calibration when mounting the instrument on an actuator, or if the printed wiring board assembly was replaced.

If you suspect calibration has changed due to drift, first perform a Valve Signature diagnostic test using ValveLink software to capture the as-found data for future root cause analysis.

## 4.2 Sensor Calibration

### Pressure Sensors

---

#### NOTE

The pressure sensor is calibrated at the factory and should not require calibration.

---

## Output Pressure Sensor

To calibrate the output pressure sensor, connect an external reference gauge to the output being calibrated. The gauge should be capable of measuring maximum instrument supply pressure. Depending upon the sensor you wish to calibrate, select either Output A Sensor or Output B Sensor. Follow the prompts on the handheld communicator display to calibrate the instrument's output pressure sensor.

1. Adjust the supply pressure regulator to the maximum instrument supply pressure. Press OK.
2. The instrument reduces the output pressure to 0. The following message appears.

USE THE INCREASE AND DECREASE SELECTIONS UNTIL THE DISPLAYED PRESSURE MATCHES THE OUTPUT X PRESSURE.

Press OK when you have read the message.

3. The value of the output pressure appears on the display. Press OK to display the adjustment menu.
4. From the adjustment menu, select the direction and size of adjustment to the displayed value.

Selecting large, medium and small adjustments causes changes of approximately 3.0 psi/0.207 bar/20.7 kPa, 0.30 psi/0.0207 bar/2.07 kPa and 0.03 psi/0.00207 bar/0.207 kPa, respectively.

If the displayed value does not match the output pressure, press OK, then repeat this step (step 4) to further adjust the displayed value. When the displayed value matches the output pressure, select Done and go to step 5.

5. The instrument sets the output pressure to full supply. The following message appears.

USE THE INCREASE AND DECREASE SELECTIONS UNTIL THE DISPLAYED PRESSURE MATCHES THE OUTPUT X PRESSURE.

Press OK when you have read the message.

6. The value of the output pressure appears on the display. Press OK to display the adjustment menu.
7. From the adjustment menu, select the direction and size of adjustment to the displayed value. If the displayed value does not match the output pressure, press OK, then repeat this step (step 7) to further adjust the displayed value. When the displayed value matches the output pressure, select Done and go to step 8.
8. Place the instrument In Service and verify that the displayed pressure matches the measured output pressure.

## Supply Pressure Sensor

To calibrate the supply pressure sensor, connect an external reference gauge to the output side of the supply regulator. The gauge should be capable of measuring maximum instrument supply pressure. Follow the prompts on the handheld communicator display to calibrate the instrument's supply pressure sensor.

1. Select a) Zero Only, or b) Zero and Span (gauge required).
  - a. If Zero Only calibration is selected, adjust the supply pressure regulator to remove supply pressure from the instrument. Press OK. Once calibration is complete, go to step 5.
  - b. If Zero and Span calibration is selected, adjust the supply pressure regulator to remove supply pressure from the instrument. Press OK. Adjust the supply regulator to the maximum instrument supply pressure. Press OK. Proceed with step 2.
2. The following message appears:

Use the Increase and Decrease selections until the displayed pressure matches the supply pressure.

Press OK when you have read this message.

3. The value of the pressure appears on the display.
4. From the adjustment menu, select the direction and size of adjustment to the displayed value.

Selecting large, medium and small adjustments causes changes of approximately 3.0 psi/0.207 bar/20.7 kPa, 0.30 psi/0.0207 bar/2.07 kPa and 0.03 psi/0.00207 bar/0.207 kPa, respectively. Adjust the displayed value until it matches the supply pressure, select Done and go to step 5.

5. Place the instrument In Service and verify that the displayed pressure matches the measured supply pressure.

## Analog Input Calibration

To calibrate the analog input sensor, connect a variable current source to the instrument LOOP+ and LOOP- terminals. The current source should be capable of generating an output of 4 to 20 mA. Follow the prompts on the handheld communicator display to calibrate the analog input sensor.

1. Set the current source to the target value shown on the display. The target value is the Input Range Low value. Press OK.
2. The following message appears:

Use the Increase and Decrease selections until the displayed current matches the target.

Press OK when you have read this message.

3. The value of the Analog Input appears on the display. Press OK to display the adjustment menu.
4. From the adjustment menu, select the direction and size of adjustment to the displayed value.

Selecting large, medium, and small adjustments causes changes of approximately 0.4 mA, 0.04 mA and 0.004 mA, respectively.

If the displayed value does not match the current source, press OK, then repeat this step (step 4) to further adjust the displayed value. When the displayed value matches the current source, select Done and go to step 5.

5. Set the current source to the target value shown on the display. The target value is the Input Range High value. Press OK.
6. The following message appears:

Use the Increase and Decrease selections until the displayed current matches the target.

Press OK when you have read this message.

7. The value of the Analog Input appears on the display. Press OK to display the adjustment menu.
8. From the adjustment menu, select the direction and size of adjustment to the displayed value. If the displayed value does not match the current source, press OK, then repeat this step (step 8) to further adjust the displayed value. When the displayed value matches the current source, select Done and go to step 9.
9. Place the instrument In Service and verify that the analog input displayed matches the current source.

## 4.3 Relay Adjustment

Before beginning travel calibration, check the relay adjustment. Replace the digital valve controller cover when finished.

---

### NOTE

Relay B and C are not user-adjustable.

---

## Double-Acting Relay

The double-acting relay is designated by “Relay A” on a label affixed to the relay itself. For double-acting actuators, the valve must be near mid-travel to properly adjust the relay. The handheld communicator will automatically position the valve when Relay Adjust is selected.

Rotate the adjustment disc, shown in Figure 13, until the output pressure displayed on the handheld communicator is between 50 and 70% of supply pressure. This adjustment is very sensitive. Be sure to allow the pressure reading to stabilize before making another adjustment (stabilization may take up to 30 seconds or more for large actuators).

If the low bleed relay option has been ordered, stabilization may take approximately two minutes longer than the standard relay.

**Figure 13. Relay A Adjustment (Shroud Removed for Clarity)**

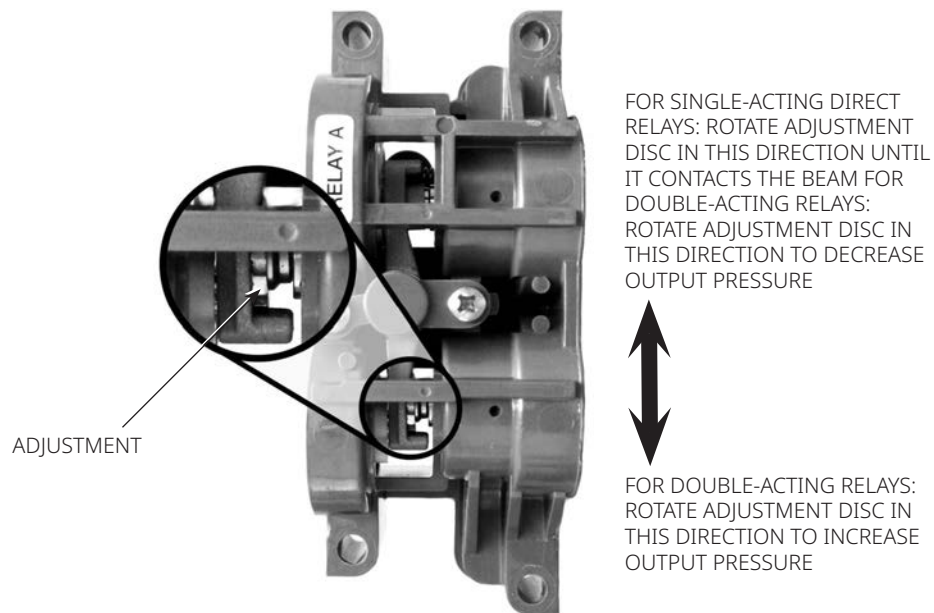

W9034

Relay A may also be adjusted for use in single-acting- direct applications. Rotate the adjustment disc as shown in Figure 13 for single-acting direct operation.

### NOTE

Care should be taken during relay adjustment as the adjustment disc may disengage if rotated too far.

## Single-Acting Relays

### **WARNING**

**For Instrument Level ODV only:**

**If the unused port is monitoring pressure, ensure that the pressure source conforms to ISA Standard 7.0.01 and does not exceed the pressure supplied to the instrument.**

**Failure to do so could result in personal injury or property damage caused by loss of process control.**

#### **Single-Acting Direct Relay**

The single-acting direct relay is designated by "Relay C" on a label affixed to the relay itself. Relay C requires no adjustment.

#### **Single-Acting Reverse Relay**

The single-acting reverse relay is designated by "Relay B" on a label affixed to the relay itself. Relay B is calibrated at the factory and requires no further adjustment.

## 4.4 PST Calibration (ODV Instrument Level Only)

This procedure permits you to run the Partial Stroke Calibration, which enables the Partial Stroke Test. It establishes values for Partial Stroke Pressure Limit, Pressure Set Point and Pressure Saturation Time for End Point Pressure Control, Travel Deviation Alert Point and Travel Deviation Time. The Partial Stroke Calibration also sets default values for max travel movement, test speed and test pause time.

---

### **NOTE**

You must take the instrument out of service before running Partial Stroke Calibration.

Ensure that the instrument is put back in service after the completing the calibration procedure.

---

# Section 5: Device Information, Alerts and Diagnostics

## 5.1 Overview

**Handheld Communicator** Overview

### Status and Primary Purpose Variables

The overview section provides basic information about the current state of the instrument and gives you access to the current values of:

- Alert Status
- Communication Status
- Instrument Mode (In/Out of Service)
- Analog Input
- Setpoint
- Travel
- Supply Pressure
- Actuator Pressure(s)
- Travel/Pressure Control Configuration

### Device Information

Device Information provides details about the instrument construction including:

- Tag Name
- Instrument Model Number
- Instrument Level (see Table 13)
- Device ID (unique number used to prevent the instrument from accepting commands intended for other instruments)
- Serial Numbers
- Firmware, DD and Hardware Revisions
- HART Universal Revision
- Write Protection (provides a procedure to enable/disable)



**Table 13. Functions Available for Instrument Level**

Instrument Level	Functions Available
HC	Communicates with handheld cmmunicator and ValveLink software. In addition, HC provides: travel cutoffs and limits, minimum opening and closing times, input characterization (linear, equal percentage, quick opening and custom), trending with ValveLink Solo, and the following alerts: travel deviation; travel alert high, low, high high and low low; drive signal; cycle counter; and travel accumulation.
AD	Includes all functions listed above plus (with ValveLink software) all offline diagnostic tests (dynamic error band, drive signal, step response and valve signature) plus online trending
PD	Includes all functions listed above plus all Performance Diagnostics online/ in-service valve testing (valve friction, electronics and mechanical condition)
ODV	Includes all functions listed above plus partial stroke test and lead/lag set point filter

## 5.2 Service Tools

<b>Handheld Communicator</b>	Service Tools
------------------------------	---------------

### Device Status

Instrument alerts, when enabled, detect many operational and performance issues that may be of interest. If there are no alerts currently active, this display will be empty.

### Alert Record

The DVC6200 will store 20 alerts. Once the alert record is full, no additional alerts will be stored until the record is cleared.

### Alert Reporting

In addition to on-board storage of alerts, the DVC6200 can report active alerts via HART Command 48 - Read Additional Status. Refer to Table 14 for a summary of the default alert settings from the factory. Following is a detailed description of the meaning of each alert.

**Table 14. Default Alert Settings**

Name	Alert	Shutdown	NE107 Category
Flash Integrity Failure	Enabled <sup>(1)</sup>	Disabled	Failure
Minor Loop Sensor Failure	Enabled <sup>(1)</sup>	Disabled	Failure
Reference Voltage Failure	Enabled <sup>(1)</sup>	Disabled	Failure
Drive Current Failure	Enabled <sup>(1)</sup>	Disabled	Failure
Critical NVM Failure	Enabled <sup>(1)</sup>	Disabled	Failure
Temperature Sensor Failure	Enabled <sup>(1)</sup>	Disabled	Failure
Pressure Sensor Failure	Enabled <sup>(1)</sup>	Disabled	Failure
Travel Sensor Failure	Enabled <sup>(1)</sup>	Disabled	Failure
Alert Record Not Empty	Disabled	Not Available	Maintenance
Calibration in Progress	Disabled	Not Available	Function Check
Diagnostics in Progress	Disabled	Not Available	Function Check
Pressure Fallback Active	Enabled	Not Available	Out of Specification
Autocal in Progress	Disabled	Not Available	Function Check
Non-Critical NVM	Enabled <sup>(1)</sup>	Disabled	Failure
Cycle Counter High	Disabled	Not Available	Maintenance
Travel Accumulator High	Disabled	Not Available	Maintenance
Instrument Time is Approximate	Disabled	Not Available	Not Available
Alert Record Full	Disabled	Not Available	Maintenance
Offline / Failed	Enabled	Not Available	Failure
Diagnostic Data Available	Disabled	Not Available	Not Available
Supply Pressure Low	Enabled	Not Available	Out of Specification
End Point Pressure Deviation	Enabled	Not Available	Out of Specification
Supply Pressure High	Enabled	Not Available	Maintenance
1. These default alert configurations cannot be changed.			

- continued -

**Table 15. Default Alert Settings (continued)**

Name	Alert	Shutdown	NE107 Category
Integrator Saturated High	Disabled	Not Available	Out of Specification
Integrator Saturated Low	Disabled	Not Available	Out of Specification
Travel Alert Low	Disabled	Not Available	Not Available
Travel Alert Low-Low	Disabled	Not Available	Not Available
Travel Alert High	Disabled	Not Available	Not Available
Travel Alert High-High	Disabled	Not Available	Not Available
Travel Deviation	Enabled	Not Available	Out of Specification
Travel Limit/Cutoff High	Disabled	Not Available	Not Available
Travel Limit/Cutoff Low	Disabled	Not Available	Not Available
Drive Signal Alert	Enabled	Not Available	Out of Specification
Output Circuit Error	Enabled	Not Available	Failure
Port A Overpressurized	Enabled	Disabled	Failure

Alert Record Full is active when the alert record is full. Additional alerts that are detected will not be saved to the alert record until the alert record is cleared.

Alert Record Not Empty is active when there are 1 or more alerts stored in the alert record.

Autocal in Progress is active when auto calibration is in progress.

Calibration in Progress is active when calibration is in progress.

Critical NVM Failure is active if there is a failure associated with NVM that is critical for instrument operation. To clear the alert, restart the instrument. If the alert persists, replace the printed wiring board assembly.

Cycle Counter High is active if the Cycle Counter exceeds the Cycle Count Alert Point. The Cycle Count records the number of times the travel changes direction when it is outside of the deadband. To clear the alert, set the Cycle Counter to a value less than the alert point. See Figure 15.

Diagnostic Data Available is active when diagnostic data has been collected and is being stored in the instrument.

Diagnostics in Progress is active when a diagnostic test is in progress.

Drive Current Failure is active when the drive current to the I/P converter is not flowing as expected. If this alert occurs, check the connection between the I/P converter and the printed wiring board assembly. Try removing the I/P converter and reinstalling it. If the alert does not clear, replace the I/P converter or the printed wiring board assembly.

Drive Signal Alert monitors the drive signal and calibrated travel. If one of the following conditions exists for more than 20 seconds, the alert is set.

For the case where Zero Power Condition is defined as closed:

Drive Signal < 10% and Calibrated Travel > 3%

Drive Signal > 90% and Calibrated Travel < 97%

For the case where Zero Power Condition is defined as open:

Drive Signal < 10% and Calibrated Travel < 97%

Drive Signal > 90% and Calibrated Travel > 3%

End Point Pressure Deviation is active if the instrument is in pressure control and the pressure is not tracking the set point within the configured deviation allowance.

Field Device Malfunction is active if the pressure, position or temperature sensors are providing invalid readings.

Flash Integrity Failure is active if there is a failure associated with flash ROM (read only memory). To clear the alert, restart the instrument. If the alert persists, replace the printed wiring board assembly.

Instrument Time is Approximate is active if the instrument has been powered down since the last time the instrument clock was set. To clear the alert, reset the instrument time.

Integrator Saturated High is active if the instrument integrator is saturated at the high extreme.

Integrator Saturated Low is active if the instrument integrator is saturated at the low extreme.

Internal Sensor Out of Limits is active if there is a problem with either the pressure sensor or the printed wiring board assembly.

Loop Current Validation Alert is active if the loop current is significantly out of range, or if there is a problem with the analog circuit electronics. To clear the alert, restart the instrument with the loop current verified to be in the 4 to 20 mA range. If the alert persists, replace the printed wiring board.

---

**NOTE**

If the control system is known to output current 24 mA or above, Shutdown on Loop Current Validation should not be enabled.

---

Minor Loop Sensor Failure is active if the pneumatic relay position reading is outside the valid range. If the alert persists, replace the printed wiring board.

Non-Critical NVM is active if there is a failure associated with NVM (nonvolatile memory) that is not critical for instrument operation. To clear the alert, restart the instrument. If the alert persists, replace the printed wiring board assembly.

Offline/Failed is active if a shutdown alert has put the device in a failed state and is therefore not controlling the input. Examine the alert(s) that caused the shutdown.

Output Circuit Error is active if the output circuit is not responding. Verify that the DIP switch on the main electronics matches the configuration of the OUT terminals. If the DIP switch setting is correct and the alert is still active, replace the main electronics.

Port A Overpressurized requires that both the Port A Overpressurized Alert and the Port A Output Pressure Limit are enabled and applies to single acting direct applications only. The alert is active if the output pressure from Port A of the DVC6200 exceeds the configured pressure limit setting. Check the supply pressure regulator for damage and verify its pressure set point.

Pressure Fallback Active is active when the instrument has detected a problem with the travel feedback and is now controlling the output like an I/P transducer.

Pressure Sensor Failure is active if any of the three pressure sensor readings (output A, output B, supply) are outside the range of 24.0 to 125.0% of the calibrated pressure for more than 60 seconds. If this alert is active, check the instrument supply pressure, ensure the printed wiring board assembly is properly mounted onto the module base assembly and ensure the pressure sensor o-rings are properly installed. If the alert persists after restarting the instrument, replace the printed wiring board assembly.

Reference Voltage Failure is active if there is a failure associated with the internal voltage reference. If this alert is active, replace the printed wiring board assembly.

Supply Pressure High is active if the supply pressure falls above the supply pressure high alert point.

Supply Pressure Low is active if the supply pressure falls below the supply pressure low alert point.

Temperature Sensor Failure is active when the instrument temperature sensor fails, or the sensor reading is outside of the range of -60 to 100 °C / -76 to 212 °F. The temperature reading is used internally for temperature compensation of inputs. If this alert is active, restart the instrument. If the alert persists, replace the printed wiring board assembly.

Travel Accumulator High is active if the Travel Accumulator exceeds the Travel Accumulator Alert Point. The Travel Accumulator totalizes the travel of the valve when the deadband is exceeded. To clear the alert, set the Travel Accumulator to a value less than the alert point. See Figure 15.

Travel Alert Hi is active when the Travel exceeds the Travel Alert Hi Point. Once the alert is active, the alert will clear when the Travel falls below the Travel Alert Hi Point minus the Travel Alert Deadband. See Figure 14.

---

**NOTE**

The Travel Alert Hi Hi and Travel Alert Lo Lo points are used to calculate the stroke time in the event of a demand. The values are typically set to 99% and 1%, respectively, however it is not necessary to enable the alert. Stroke time can be read from the device with ValveLink software.

---

Travel Alert Hi-Hi is active when the Travel exceeds the Travel Alert Hi Hi Point. Once the alert is active, the alert will clear when the Travel falls below the Travel Alert Hi Hi Point minus the Travel Alert Deadband. See Figure 14.

Travel Alert Lo is active when the Travel is below the Travel Alert Lo Point. Once the alert is active, the alert will clear when the Travel exceeds the Travel Alert Lo Point plus the Travel Alert Deadband. See Figure 14.

Travel Alert Lo-Lo is active when the Travel is below the Travel Alert Lo Point. Once the alert is active, the alert will clear when the Travel exceeds the Travel Alert Lo Point plus the Travel Alert Deadband. See Figure 14.

Travel Limit/Cutoff Hi is active when the Travel exceeds the Hi Limit/Cutoff Point.

Travel Limit/Cutoff Lo is active when the Travel falls below the Lo Limit/Cutoff Point.

Travel Deviation— If the difference between the Travel Target and the Travel exceeds the Travel Deviation Alert Point for more than the Travel Deviation Time, the Travel Deviation Alert is active. It remains active until the difference between the travel target and the Travel is less than the Travel Deviation Alert Point minus the Travel Alert Deadband. See Figure 14.

Travel Sensor Failure is active if the sensed travel is outside the range of 25.0 to 125.0% of calibrated travel. If this alert is active, check the instrument mounting. Also, check that the electrical connection from the travel sensor is properly plugged into the printed wiring board assembly. After restarting the instrument, if the alert persists, troubleshoot the printed wiring board assembly or travel sensor.

Variable out of Range is active if one or more of the measured analog sensor readings (loop current, pressure, temperature or travel) is saturated or reading out of its configured range. The condition may be due to improper configuration or physical setup and not be due to a sensor malfunction.

## Deadband Principle of Operation

The deadband is the percent (%) of ranged travel around a travel reference point where no change in alert status will occur. This prevents the alert from toggling on and off when operating near the alert point.

The Travel Alert Deadband applies to the Travel Deviation Alert as well as the Travel Alert Hi, Lo, Hi Hi and Lo Lo. Figure 14 illustrates the principle behind setting and clearing a Travel Alert Hi. The alert is set when the travel exceeds the alert point, and is cleared when it falls below the deadband.

Figure 14. Travel Alert Deadband

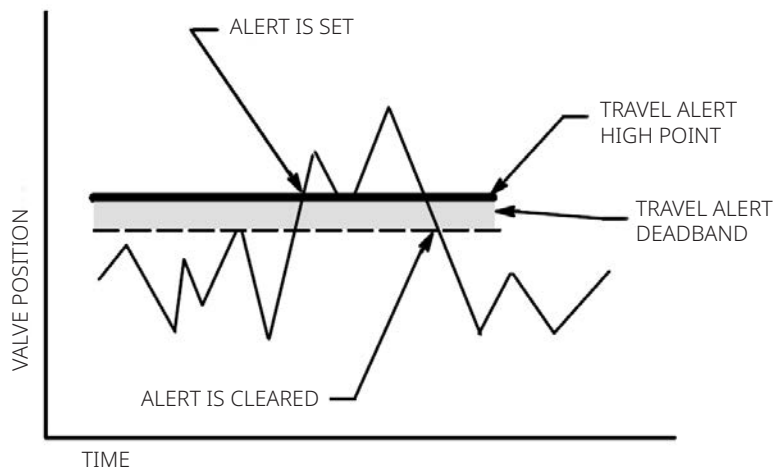

A6532

The Cycle Counter and Travel Accumulator Deadband applies to both the Cycle Count High Alert and the Travel Accumulator High Alert. The deadband establishes a zone around a travel reference point. The travel reference point gets reestablished to the point of travel reversal that occurs outside of the deadband. The deadband must be exceeded before a change in travel direction will be counted as a cycle and the accumulated travel (up to the point of travel reversal) is added to the total accumulation. See Figure 15.

Figure 15. Cycle Counter and Travel Accumulator Deadband Example (Set at 10%)

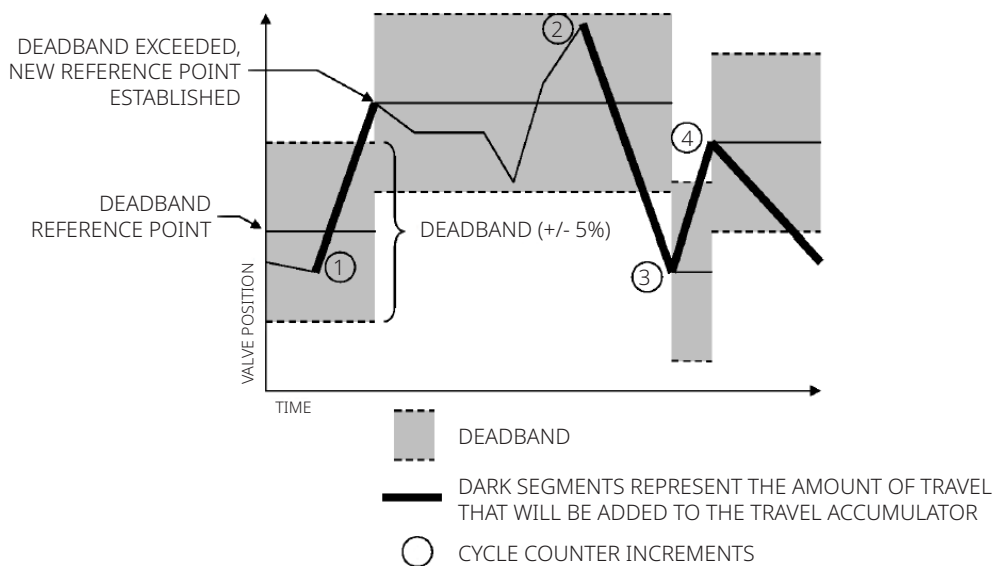

E1473

## Diagnostics

### Stroke Valve

Follow the prompts on the handheld communicator display to select from the following:

- Done—Select this if you are done. All ramping is stopped when DONE is selected.
- Ramp Open—ramps the travel toward open at the rate of 1.0% per second of the ranged travel.
- Ramp Closed—ramps the travel toward closed at the rate of 1.0% per second of the ranged travel.
- Ramp to Target—ramps the travel to the specified target at the rate of 1.0% per second of the ranged travel.
- Step to Target—steps the travel to the specified target.

### Partial Stroke Test

---

**NOTE**

Partial Stroke Test is only available for instrument level ODV.

---

The Partial Stroke Test allows DVC6200 digital valve controllers with instrument level ODV to perform a Valve Signature type of test while the instrument is in service and operational. In some applications, it is important to be able to exercise and test the valve to verify that it will operate when commanded. This feature allows the user to partially stroke the valve while continually monitoring the input signal. If a demand arises, the test is aborted and the valve moves to its commanded position. The partial stroke valve travel is configurable between 1 and 30% maximum travel, in 0.1% increments. Data from the last partial stroke test is stored in the instrument memory for retrieval by ValveLink software.

The Partial Stroke Test allows you to perform a partial, 10%, stroke test (standard) or a custom stroke test. With the custom stroke test, the stroke may be extended up to 30%. Be sure to check plant guidelines before performing a custom stroke test. The purpose of this test is to ensure that the valve assembly moves upon demand.

A partial stroke test can be initiated when the valve is operating at either 4 or 20 mA (point-to-point mode).

When enabled, a partial stroke test may be initiated by the device (as a scheduled, auto partial stroke test), a remote pushbutton located in the field or at the valve, a handheld communicator, or ValveLink software.

For information on configuring the Partial Stroke Test, see Partial Stroke Variables in the Detailed Setup section.



- Automatic (Scheduled)

The Auto Partial Stroke Test allows the partial stroke test to be scheduled by the DVC6200. The test is scheduled in number of hours between tests. Any power cycle will reset the test clock timer.

- Local Pushbutton

A partial stroke test command may be sent to the digital valve controller using a set of contacts wired to the auxiliary +/- terminals. To perform a test, the contacts must be closed for 3 to 5 seconds and then opened. To abort the test, close the contacts for 1 second. The last set of diagnostic data is stored in the instrument memory for later retrieval via ValveLink software.

- Handheld Communicator

1. Connect the handheld communicator to the LOOP terminals on the digital valve controller.
2. Turn on the handheld communicator.
3. From the Online menu, select Service Tools > Diagnostics > Partial Stroke Test.
4. Select either Standard (10%) or Custom. With the Custom Stroke Test, the stroke may be entered up to 30% with configurable stroking speed and pause time.
5. The currently configured Stroke, Stroking Speed, and Pause Time is displayed. Choose "Yes" to run the test using these values. Choose "No" to modify the values. The default value for Stroke Speed is 0.25%/second.
6. The valve begins to move and the actual travel reported by the digital valve controller is displayed on the handheld communicator.
7. Once the valve has reached the endpoint, check that the valve has reached the desired set point. The valve should return to its original position.

- ValveLink Software

Run the Partial Stroke diagnostic.

## Solenoid Valve Health Monitoring

Solenoid valve health monitoring requires the following setup:

- Single-acting actuator
- Solenoid valve installed between the DVC6200 pressure output and the actuator
- Unused output pressure port of the DVC6200 connected between the solenoid and the actuator, close to the actuator
- Relay configured as "special application"
- Triggered profile enabled and the "Pressure Differential" trigger event selected.

If the solenoid valve is wired directly to the logic solver, the following steps can be used to test the solenoid valve.

1. Momentarily interrupt the power to the solenoid valve through the Logic Solver (typically 100 to 200 milliseconds). The duration of the interruption should be short enough so that the safety valve travel does not move, but long enough so that a pressure drop across the solenoid valve is detected.
2. Properly configured, data collection will occur automatically and will be stored onboard the DVC6200.
3. With ValveLink software, upload the diagnostic data from the triggered profile menu.
4. Examine the graph and observe that there was a change in the pressure reading downstream of the solenoid.

## 5.3 Variables

**Handheld Communicator** Service Tools > Variables

The Variables section provides current values of the instrument variables. Below is a list of the variables available for viewing:

- Write Protection (also provides a procedure to enable/disable)
- Instrument Mode (also provides a procedure to place in/out of service)
- Analog Input
- Setpoint
- Travel
- Drive Signal
- Input Characterization (also provides a procedure to modify)
- Cycle Counter
- Travel Accumulator
- Supply Pressure
- Actuator Pressure(s)
- Travel/Pressure Control Configuration (also provides a procedure to modify)
- Control Mode (also provides a procedure to modify)
- Instrument Temperature
- Travel Counts (this is the raw travel sensor reading used for advanced adjustments)
- Maximum Recorded Temperature
- Minimum Recorded Temperature
- Number of Power Ups
- Days Powered Up

## Section 6: Maintenance and Troubleshooting

The DVC6200 digital valve controller enclosure is rated Type 4X and IP66, therefore periodic cleaning of internal components is not required. If the DVC6200 is installed in an area where the exterior surfaces tend to get heavily coated or layered with industrial or atmospheric contaminants, it is recommended that the vent (key 52) be periodically removed and inspected to ensure there is no partial or full obstruction. If the vent appears to be partially or fully obstructed, it must be cleaned or replaced. Lightly brush the exterior of the vent to remove contaminants and run a mild water/detergent solution through the vent to ensure it is free of any obstruction. Allow the vent to dry before reinstalling.

### **WARNING**

**Personal injury or property damage can occur from cover failure due to overpressure. Ensure that the housing vent opening is open and free of debris to prevent pressure buildup under the cover.**

### **WARNING**

**To avoid static discharge from the plastic cover when flammable gases or dust are present, do not rub or clean the cover with solvents. To do so could result in a spark that may cause the flammable gases or dust to explode, resulting in personal injury or property damage. Clean with a mild detergent and water only.**

### **WARNING**

**Avoid personal injury or property damage from sudden release of process pressure or bursting of parts. Before performing any maintenance procedures on the DVC6200 digital valve controller:**

- **Always wear protective clothing, gloves and eyewear.**
- **Do not remove the actuator from the valve while the valve is still pressurized.**
- **Disconnect any operating lines providing air pressure, electric power or a control signal to the actuator. Be sure the actuator cannot suddenly open or close the valve.**
- **Use bypass valves or completely shut off the process to isolate the valve from process pressure. Relieve process pressure from both sides of the valve.**
- **Use lock-out procedures to be sure that the above measures stay in effect while you work on the equipment.**

- **Check with your process or safety engineer for any additional measures that must be taken to protect against process media.**
  - **Vent the pneumatic actuator loading pressure and relieve any actuator spring precompression so the actuator is not applying force to the valve stem; this will allow for the safe removal of the stem connector.**
- 

### **WARNING**

When using natural gas as the supply medium or for explosion proof applications, the following warnings also apply:

- **Remove electrical power before removing the housing cap. Personal injury or property damage from fire or explosion may result if power is not disconnected before removing the cap.**
  - **Remove electrical power before disconnecting any of the pneumatic connections**
  - **When disconnecting any of the pneumatic connections or any pressure retaining part, natural gas will seep from the unit and any connected equipment into the surrounding atmosphere. Personal injury or property damage may result from fire or explosion if natural gas is used as the supply medium and appropriate preventive measures are not taken. Preventive measures may include, but are not limited to, one or more of the following: ensuring adequate ventilation and the removal of any ignition sources.**
  - **Ensure that the cover is correctly installed before putting this unit back into service. Failure to do so could result in personal injury or property damage from fire or explosion.**
- 

### **WARNING**

**When replacing components, use only components specified by the factory. Always use proper component replacement techniques, as presented in this manual. Improper techniques or component selection may invalidate the approvals and the product specifications, as indicated in Table 2. It may also impair operations and the intended function of the device and could cause personal injury and property damage.**

---

Because of the diagnostic capability of the DVC6200, predictive maintenance is available through the use of ValveLink software. Using the digital valve controller, valve and instrument maintenance can be enhanced, thus avoiding unnecessary maintenance. For information on using ValveLink software, refer to the ValveLink software online help.

## 6.1 Removing the Magnetic Feedback Assembly

To remove the magnet assembly from the actuator stem, perform the following basic steps.

1. Make sure that the valve is isolated from the process.
2. Remove the instrument terminal box cover.
3. Disconnect the field wiring from the terminal board.
4. Shut off the instrument air supply.
5. Disconnect the pneumatic tubing and remove the DVC6200 or the DVC6215 from the actuator.
6. Remove the screws holding the magnet assembly to the connector arm.

When replacing the instrument, be sure to follow the mounting guidelines in the quick start guide (D103556X012) that shipped with the digital valve controller. Setup and calibrate the instrument prior to returning to service.

## 6.2 Module Base Maintenance

The digital valve controller contains a module base consisting of the I/P converter, printed wiring board assembly and pneumatic relay. The module base may be easily replaced in the field without disconnecting field wiring or tubing.

### Tools Required

Table 16 lists the tools required for maintaining the DVC6200 digital valve controller.

**Table 16. Tools Required**

Tool	Size	Component
Phillips Screwdriver		Relay, printed wiring board assembly and cover screws
Hex key	5 mm	Terminal box screw
Hex key	1.5 mm	Terminal box cover screw
Hex key	2.5 mm	I/P converter screws
Hex key	6 mm	Module base screws

### Component Replacement

When replacing any of the components of the DVC6200, the maintenance should be performed in an instrument shop whenever possible. Make sure that the electrical wiring and pneumatic tubing is disconnected prior to disassembling the instrument.

## Removing the Module Base

Refer to Figure 23 or 25 for key number locations.

### **⚠ WARNING**

**To avoid personal injury or equipment damage from bursting of parts, turn off the supply pressure to the digital valve controller and bleed off any excess supply pressure before attempting to remove the module base assembly from the housing.**

1. Unscrew the four captive screws in the cover (key 43) and remove the cover from the module base (key 2).
2. Using a 6 mm hex socket wrench, loosen the three-socket head screws (key 38). These screws are captive in the module base by retaining rings (key 154).

### **NOTE**

The module base is linked to the housing by two cable assemblies. Disconnect these cable assemblies after you pull the module base out of the housing.

3. Pull the module base straight out of the housing (key 1). Once clear of the housing, swing the module base to the side of the housing to gain access to the cable assemblies.
4. The digital valve controller/base unit has two cable assemblies, shown in Figure 16, which connect the module base, via the printed wiring board assembly, travel sensor and the terminal box. Disconnect these cable assemblies from the printed wiring board assembly on the back of the module base.

**Figure 16. Printed Wiring Board Cable Connections**

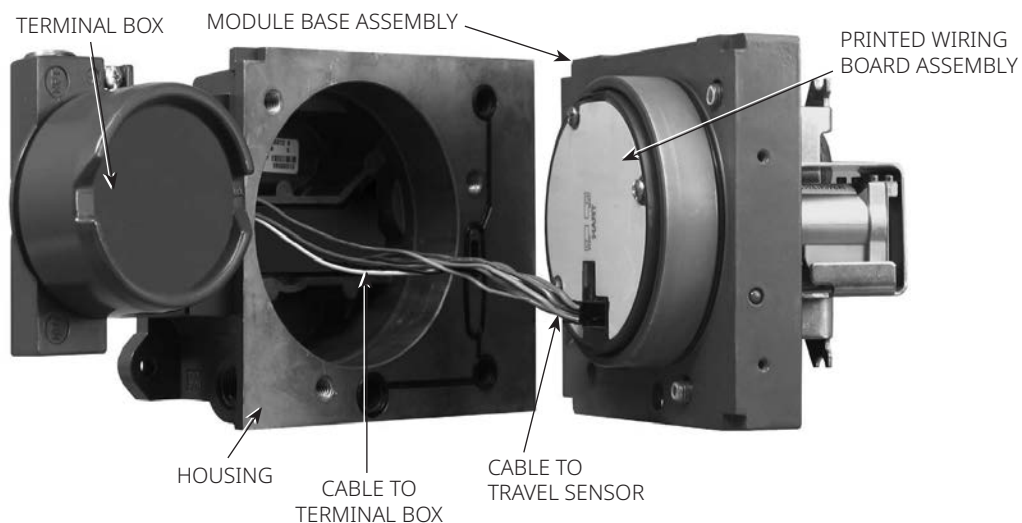

W9924-1\_no label

## Replacing the Module Base

Refer to Figure 23 or 25 for key number locations.

### NOTICE

**To avoid affecting performance of the instrument, take care not to damage the module base seal or guide surface. Do not bump or damage the bare connector pins on the PWB assembly. Damaging either the module base or guide surface may result in material damage, which could compromise the instruments ability to maintain a pressure seal.**

### NOTE

To avoid affecting performance of the instrument, inspect the guide surface on the module and the corresponding seating area in the housing before installing the module base assembly. These surfaces must be free of dust, dirt, scratches and contamination.

Ensure the module base seal is in good condition. Do not reuse a damaged or worn seal.

1. Ensure the module base seal (key 237) is properly installed in the housing (key 1). Ensure the O-ring (key 12) is in place on the module base assembly.
2. Connect the travel sensor and terminal box cable assemblies to the PWB assembly (key 50). Orientation of the connector is required.
3. Insert the module base (key 2) into the housing (key 1).

### NOTE

For stainless steel digital valve controllers pipe thread sealant (key 64) is recommended under the head of the three socket head screws (key 38) prior to attaching the module base to the housing in the next step.

4. Install three socket head screws (key 38) in the module base into the housing. If not already installed, press three retaining rings (key 154) into the module base. Evenly tighten the screws in a crisscross pattern to a final torque of 16 N•m / 138 lbf•in.

### NOTICE

**Disruption of process control can result if the cable assemblies/wiring are damaged when attaching the cover to the module base assembly.**

**Ensure that the cable assemblies/wiring are positioned in the cavity of the module base so they do not get compressed or damaged when attaching the cover to the module base assembly in step 5.**

5. Attach the cover (key 43) to the module base assembly.

## 6.3 Submodule Maintenance

The module base of the DVC6200 contains the following submodules: I/P converter, PWB assembly and pneumatic relay. If problems occur, these submodules may be removed from the module base and replaced with new submodules. After replacing a submodule, the module base may be put back into service.

### **NOTICE**

**Exercise care when performing maintenance on the module base. Reinstall the cover to protect the I/P converter and gauges when servicing other submodules.**

**In order to maintain accuracy specifications, do not strike or drop the I/P converter during submodule maintenance.**

### I/P Converter

Refer to Figure 23 or 25 for key number locations. The I/P converter (key 41) is located on the front of the module base.

### **NOTE**

After I/P converter submodule replacement, calibrate the digital valve controller to maintain accuracy specifications.

### Replacing the I/P Filter

A screen in the supply port beneath the I/P converter serves as a secondary filter for the supply medium. To replace this filter, perform the following procedure:

1. Remove the I/P converter (key 41) and shroud (key 169) as described in the Removing the I/P Converter procedure.
2. Remove the screen (key 231) from the supply port.
3. Install a new screen in the supply port as shown in Figure 17.



**Figure 17. I/P Filter Location**

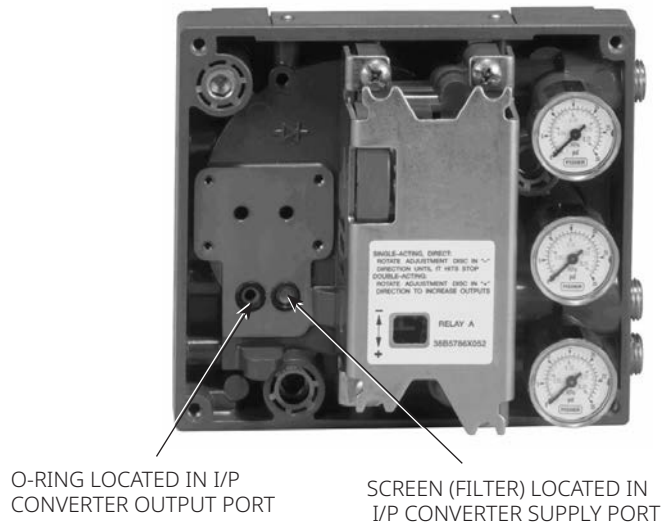

W8072

4. Inspect the O-ring (key 39) in the I/P output port. if necessary, replace it.
5. Reinstall the I/P converter (key 41) and shroud (key 169) as described in the Replacing the I/P Converter procedure.

## Removing the I/P Converter

1. Remove the front cover (key 43), if not already removed.
2. Refer to Figure 18. Using a 2.5 mm hex socket wrench, remove the four socket-head screws (key 23) that attach the shroud (key 169) and I/P converter (key 41) to the module base (key 2).
3. Remove the shroud (key 169); then pull the I/P converter (key 41) straight out of the module base (key 2). Be careful not to damage the two electrical leads that come out of the base of the I/P converter.
4. Ensure that the O-ring (key 39) and screen (key 231) stay in the module base and do not come out with the I/P converter (key 41).

## Replacing the I/P Converter

1. Refer to Figure 17. Inspect the condition of the O-ring (key 39) and screen (key 231) in the module base (key 2). Replace them, if necessary. Apply silicone lubricant to the O-rings.
2. Ensure the two boots (key 210) shown in Figure 18 are properly installed on the electrical leads.

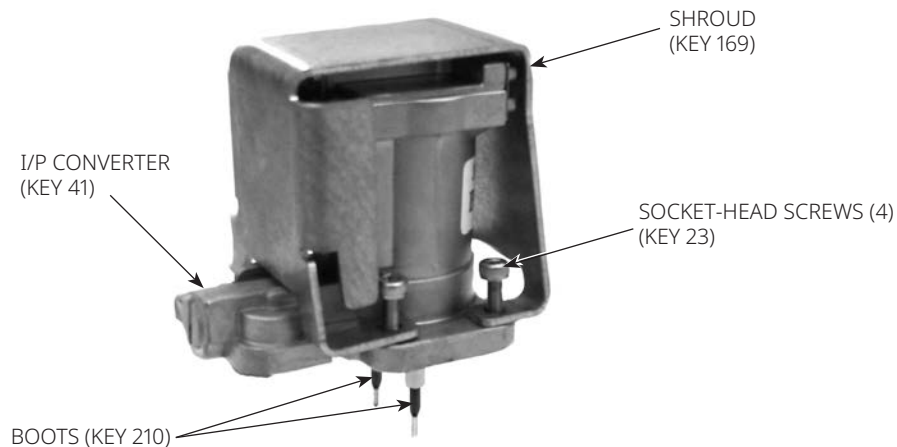
**Figure 18. I/P Converter**

W9328

3. Install the I/P converter (key 41) straight into the module base (key 2), taking care that the two electrical leads feed into the guides in the module base. These guides route the leads to the printed wiring board assembly submodule.
4. Install the shroud (key 169) over the I/P converter (key 41).
5. Install the four socket-head screws (key 23) and evenly tighten them in a crisscross pattern to a final torque of 1.6 N•m / 14 lbf•in.
6. After replacing the I/P converter, calibrate travel or perform touch-up calibration to maintain accuracy specifications.

## Printed Wiring Board (PWB) Assembly

Refer to Figure 23 or 25 for key number locations. The PWB assembly (key 50) is located on the back of the module base assembly (key 2).

### NOTE

If the PWB assembly submodule is replaced, calibrate and configure the digital valve controller to maintain accuracy specifications.

## Removing the Printed Wiring Board Assembly

1. Separate the module base from the housing by performing the Removing the Module Base procedure.
2. Remove three screws (key 33).
3. Lift the PWB assembly (key 50) straight out of the module base (key 2).
4. Ensure that the O-rings (key 40) remain in the pressure sensor bosses on the module base assembly (key 2) after the PWB assembly (key 50) has been removed.

## Replacing the Printed Wiring Board Assembly and Setting the DIP Switch

1. Apply silicone lubricant to the pressure sensor O-rings (key 40) and install them on the pressure sensor bosses in the module base assembly.
2. Properly orient the PWB assembly (key 50) as you install it into the module base. The two electrical leads from the I/P converter (key 41) must guide into their receptacles in the PWB assembly and the pressure sensor bosses on the module base must fit into their receptacles in the PWB assembly.
3. Push the PWB assembly (key 50) into its cavity in the module base.
4. Install and tighten three screws (key 33) to a torque of 1 N•m / 10.1 lbf•in.
5. Set the DIP switch on the PWB assembly according to Table 17.

**Table 17. DIP Switch Configuration<sup>(1)</sup>**

Switch Label	Operational Mode	DIP Switch Position
PT-PT	4 to 20 mA Point-to-Point Loop	LEFT
Multi	24 V DC Multi-Drop Loop	RIGHT

1. Refer to Figure 19 for switch location.

**Figure 19. Printed Wiring Board (PWB) Connections and Settings**

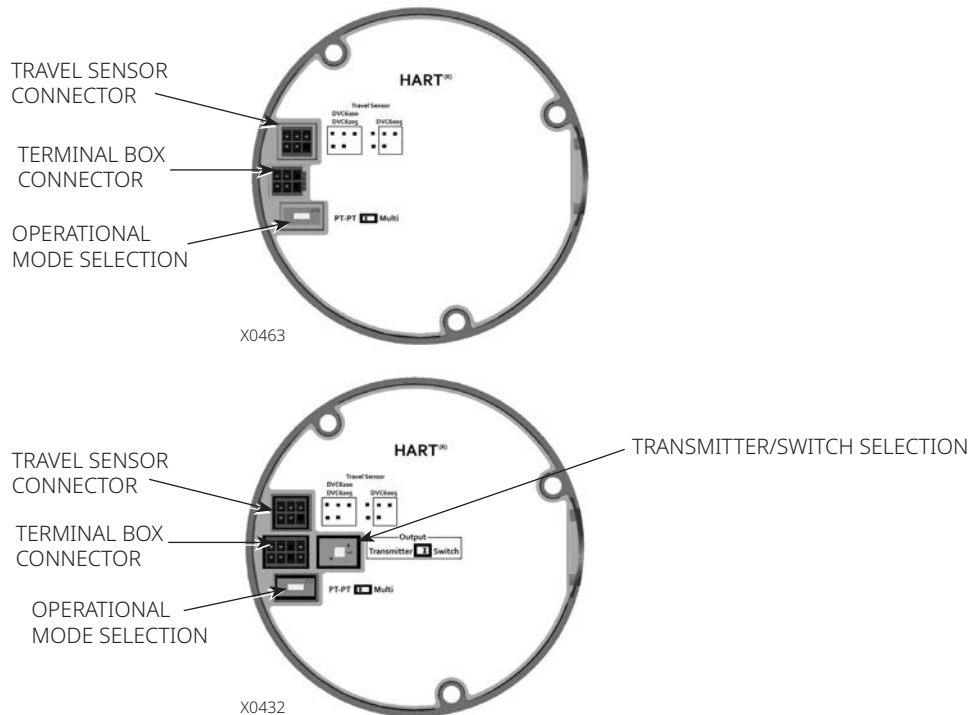

---

**NOTE**

For the digital valve controller to operate with a 4 to 20 mA control signal, be sure the DIP switch is in the point-to-point loop position.

---

6. Reassemble the module base to the housing by performing the Replacing the Module Base procedure.
7. Setup and calibrate the digital valve controller.

## Pneumatic Relay

Refer to Figure 23 or 25 for key number locations. The pneumatic relay (key 24) is located on the front of the module base.

---

**NOTE**

After relay submodule replacement, calibrate the digital valve controller to maintain accuracy specifications.

---

## Removing the Pneumatic Relay

1. Loosen the four screws that attach the relay (key 24) to the module base. These screws are captive in the relay.
2. Remove the relay.

## Replacing the Pneumatic Relay

1. Visually inspect the holes in the module base to ensure they are clean and free of obstructions. If cleaning is necessary, do not enlarge the holes.
  2. Apply silicone lubricant to the relay seal and position it in the grooves on the bottom of the relay as shown in Figure 20. Press small seal retaining tabs into retaining slots to hold relay seal in place.
- 

**Figure 20. Pneumatic Relay Assembly**

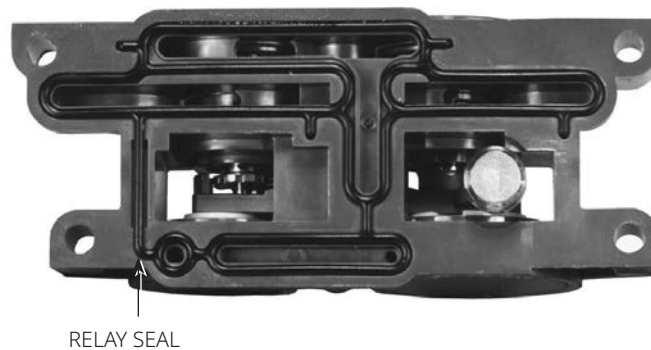

W8074

---

3. Position the relay (with shroud) on the module base. Tighten the four screws, in a crisscross pattern, to a final torque of 2 N•m / 20.7 lbf•in.
4. Using the handheld communicator, verify that the value for Relay Type parameter matches the relay type installed.
5. After replacing the relay and verifying the relay type, calibrate travel or perform touch-up calibration to maintain accuracy specifications.

## Gauges, Pipe Plugs or Tire Valves

Depending on the options ordered, the DVC6200 or DVC6205 will be equipped with either gauges (key 47), pipe plugs (key 66) or tire valves (key 67). Single-acting instruments will also have a screen (key 236, Figure 25). These are located on the top of the module base next to the relay. Perform the following procedure to replace the gauges, tire valves or pipe plugs. Refer to Figures 23 and 24 for key number locations.

1. Remove the front cover (key 43).
2. Remove the gauge, pipe plug or tire valve as follows:  
For gauges (key 47), the flats are on the gauge case. Use a wrench on the flats of the gauge to remove the gauge from the module base. For double-acting instruments, to remove the supply gauge, remove one of the output gauges.  
For pipe plugs (key 66) and tire valves (key 67), use a wrench to remove these from the module base.
3. Apply pipe thread sealant (key 64) to the threads of the replacement gauges, pipe plugs or tire valves.
4. Using a wrench, screw the gauges, pipe plugs or tire valves into the module base.

## 6.4 Terminal Box

Refer to Figure 23 or 25 for key number locations.

The terminal box is located on the housing and contains the terminal strip assembly for field wiring connections.

---

### NOTE

The DVC6205 feedback connections terminal box (shown in Figure 21) is not a replaceable part. Do not remove the tamper proof paint on the screw.

---

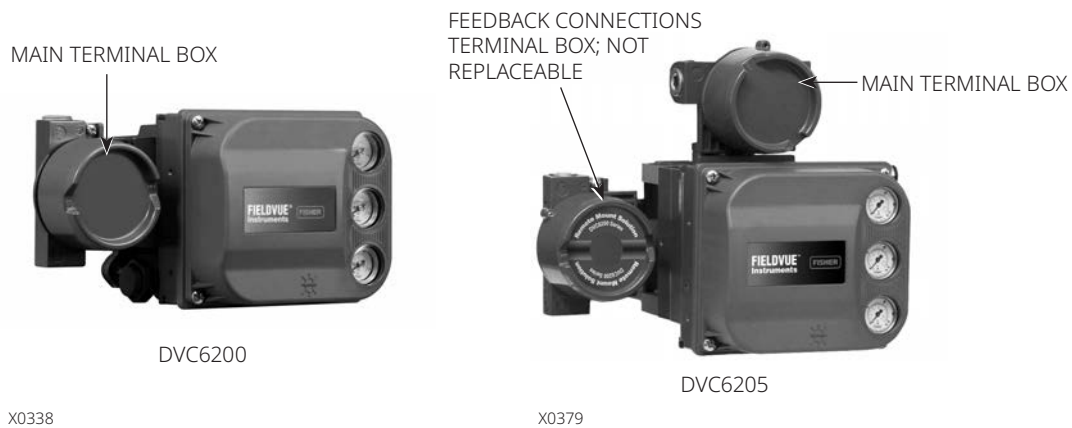
**Figure 21. Terminal Boxes**

## Removing the Terminal Box

### **⚠ WARNING**

**To avoid personal injury or property damage caused by fire or explosion, remove power to the instrument before removing the terminal box cover in an area which contains a potentially explosive atmosphere or has been classified as hazardous.**

1. Loosen the set screw (key 58) in the cap (key 4) so that the cap can be unscrewed from the terminal box.
2. After removing the cap (key 4), note the location of field wiring connections and disconnect the field wiring from the terminal box.
3. Separate the module base from the housing by performing the Removing the Module Base procedure.
4. Disconnect the terminal box wiring connector from the PWB assembly (key 50).
5. Remove the screw (key 72). Pull the terminal box assembly straight out of the housing.

## Replacing the Terminal Box

### **NOTE**

Inspect all O-rings for wear and replace as necessary.

1. Apply lubricant, silicone sealant to the O-ring (key 34) and install the O-ring over the stem of the terminal box.
2. Insert the terminal box assembly stem into the housing until it bottoms out. Position the terminal box assembly so that the hole for the screw (key 72) in the terminal box aligns with the threaded hole in the housing. Install the screw (key 72).
3. Connect the terminal box wiring connector to the PWB assembly (key 50). Orientation of the connector is required.
4. Reassemble the module base to the housing by performing the Replacing the Module Base procedure.
5. Reconnect the field wiring as noted in step 2 in the Removing the Terminal Box procedure.
6. Apply lubricant, silicone sealant to the O-ring (key 36) and install the O-ring over the 2-5/8 in. threads of the terminal box. Use of a tool is recommended to prevent cutting the O-ring while installing it over the threads.
7. Apply lithium grease (key 63) to the 2-5/8 in. threads on the terminal box to prevent seizing or galling when the cap is installed.
8. Screw the cap (key 4) onto the terminal box until no gap remains.
9. Install the set screw (key 58) into the cap (key 4). Secure the cap by engaging the set screw.

## 6.5 Troubleshooting

If communication or output difficulties are experienced with the instrument, refer to the troubleshooting chart in Table 18. Also see the DVC6200 Technical Support Checklist on page 80.

## 6.6 Checking Voltage Available

### WARNING

**Personal injury or property damage caused by fire or explosion may occur if this test is attempted in an area which contains a potentially explosive atmosphere or has been classified as hazardous.**

To check the Voltage Available at the instrument, perform the following:

1. Connect the equipment in Figure 5 to the field wiring in place of the FIELDVUE instrument.
2. Set the control system to provide maximum output current.
3. Set the resistance of the 1 kilohm potentiometer shown in Figure 5 to zero.
4. Record the current shown on the milliammeter.
5. Adjust the resistance of the 1 kilohm potentiometer until the voltage read on the voltmeter is 10.0 V.

6. Record the current shown on the milliammeter.
7. If the current recorded in step 6 is the same as that recorded in step 4 ( $\pm 0.08$  mA), the voltage available is adequate.
8. If the voltage available is inadequate, refer to Wiring Practices in the Installation section.

## 6.7 Restart Processor

**Handheld Communicator** Service Tools > Maintenance > Restart Processor

This is a “soft” reset of the device. This procedure can only be performed while the instrument is out of service. A soft reset will immediately put into effect changes that have been sent to the instrument. Also, if the device is configured to shutdown on an alert, the soft reset will clear the shutdown.

**Table 18. Instrument Troubleshooting**

Symptom	Possible Cause	Action
Analog input reading at instrument does not match actual current provided.	Control mode not Analog.	Check the control mode using the handheld communicator. If in the Digital or Test mode, the instrument receives its set point as a digital signal. Control is not based on input current. Change Control Mode to Analog.
	Low control system compliance voltage.	Check system compliance voltage (see Wiring Practices in the Installation section).
	Instrument shutdown due to self test failure.	Check instrument status using the handheld communicator (see Viewing Instrument Status in the Viewing Device Information section).
	Analog input sensor not calibrated.	Calibrate the analog input sensor (see Analog Input Calibration in the Calibration section).
	Current leakage.	Excessive moisture in the terminal box can cause current leakage. Typically the current will vary randomly if this is the case. Allow the inside of the terminal box to dry, then retest.
Instrument will not communicate.	Insufficient Voltage Available.	Calculate Voltage Available (see Wiring Practices in the Installation section). Voltage Available should be greater than or equal to 10 V DC.
	Controller output Impedance too low.	Install a HART filter after reviewing Control System Compliance Voltage requirements (see Wiring Practices in the Installation section).
	Cable capacitance too high.	Review maximum cable capacitance limits (see Wiring Practices in the Installation section).
	HART filter improperly adjusted.	Check filter adjustment (see the appropriate HART filter instruction manual).
	Improper field wiring.	Check polarity of wiring and integrity of connections. Make sure cable shield is grounded only at the control system.

- continued -



**Table 18. Instrument Troubleshooting (continued)**

Symptom	Possible Cause	Action
Instrument will not communicate.	Controller output providing less than 4 mA to loop.	Check control system minimum output setting, which should not be less than 3.8 mA.
	Disconnected loop wiring cable at PWB.	Verify connectors are plugged in correctly.
	PWB DIP switch not set properly.	Check for incorrect setting or broken DIP switch on the back of the PWB. Reset switch or replace PWB, if switch is broken. See Table 17 for switch setting information.
	PWB failure.	Use a 4 to 20 mA current source to apply power to the instrument. Terminal voltage across the LOOP+ and LOOP- terminals should be 8.0 to 9.5 V DC. If the terminal voltage is not 8.0 to 9.5 V DC, replace the PWB.
	Polling address incorrect.	Use the handheld communicator to set the polling address (refer to the Detailed Setup section). From the Utility menu, select <i>Configure Communicator &gt; Polling &gt; Always Poll</i> . Set the instrument polling address to 0.
	Defective terminal box.	Check continuity from each screw terminal to the corresponding PWB connector pin. If necessary, replace the terminal box assembly.
	Defective handheld communicator or ValveLink modem cable.	If necessary, repair or replace cable.
	ValveLink modem defective or not compatible with PC.	Replace ValveLink modem.
	ValveLink hardlock defective or not programmed.	Replace if defective or return to factory for programming.
Instrument will not calibrate, has sluggish performance or oscillates.	Configuration errors.	Verify configuration: If necessary, set protection to None. If Out of Service, place In Service. Check: Travel Sensor Motion, Tuning set, Zero Power Condition, Feedback Connection, Control mode (should be Analog), Restart control mode (should be Analog)
	Restricted pneumatic passages in I/P converter.	Check screen in I/P converter supply port of the module base. Replace if necessary. If passages in I/P converter restricted, replace I/P converter.
	O-ring(s) between I/P converter ass'y missing or hard and flattened losing seal.	Replace O-ring(s).

- continued -

**Table 18. Instrument Troubleshooting (continued)**

Symptom	Possible Cause	Action
Instrument will not calibrate, has sluggish performance or oscillates.	I/P converter ass'y damaged/corroded/clogged.	Check for bent flapper, open coil (continuity), contamination, staining or dirty air supply. Coil resistance should be between 1680 to 1860 ohms. Replace I/P assembly if damaged, corroded, clogged or open coil.
	I/P converter ass'y out of spec.	I/P converter ass'y nozzle may have been adjusted. Verify drive signal (55 to 80% for double-acting; 60 to 85% for single-acting) with the valve off the stops. Replace I/P converter assembly if drive signal is continuously high or low.
	Defective module base seal.	Check module base seal for condition and position. If necessary, replace seal.
	Defective relay.	Depress relay beam at adjustment location in shroud, look for increase in output pressure. Remove relay, inspect relay seal. Replace relay seal or relay if I/P converter assembly is good and air passages not blocked. Check relay adjustment.
	Defective 67CFR regulator, supply pressure gauge jumps around.	Replace 67CFR regulator.
ValveLink diagnostic tests provide erroneous results.	Defective pressure sensor.	Replace PWB.
	Pressure sensor O-ring missing.	Replace O-ring.
Handheld communicator does not turn on.	Battery pack not charged.	Charge battery pack. Note: Battery pack can be charged while attached to the handheld communicator or separately. The handheld communicator is fully operable while the battery pack is charging. Do not attempt to charge the battery pack in a hazardous area.

## 6.8 DVC6200 Technical Support Checklist

Have the following information available prior to contacting your [Emerson sales office](#) for support.

1. Instrument serial number as read from nameplate \_\_\_\_\_
2. Is the digital valve controller responding to the control signal? Yes \_\_\_\_\_ No \_\_\_\_\_
3. If not, describe \_\_\_\_\_
4. Measure the voltage across the "Loop -" and Loop +" terminal box screws when the commanded current is 4.0 mA and 20.0 mA: \_\_\_\_\_ V @ 4.0 mA \_\_\_\_\_ V @ 20.0 mA. (These values should be around 8.6 V @ 4.0 mA and 8.8 V @ 20 mA).
5. Is it possible to communicate via HART to the digital valve controller? Yes \_\_\_ No \_\_\_
6. What is the Diagnostic Tier of the digital valve controller?  
AC \_\_\_ HC \_\_\_ AD \_\_\_ PD \_\_\_ ODV\_\_\_
7. What is the firmware version of the digital valve controller? \_\_\_\_\_
8. What is the hardware version of the digital valve controller? \_\_\_\_\_
9. Is the digital valve controller's Instrument Mode "In Service"? Yes \_\_\_\_\_ No \_\_\_\_\_
10. Is the digital valve controller's Control Mode set to "Analog"? Yes \_\_\_\_\_ No \_\_\_\_\_
11. Is it on Travel or Pressure control?
12. What are the following parameter readings?  
Input Signal \_\_\_\_\_ Drive Signal \_\_\_\_\_ %  
Supply Pressure \_\_\_\_\_ Pressure A \_\_\_\_\_ Pressure B \_\_\_\_\_  
Travel Target \_\_\_\_\_ % Travel \_\_\_\_\_ %
13. What are the following alert readings?
14. Fail alerts \_\_\_\_\_
15. Valve alerts \_\_\_\_\_
16. Operational status \_\_\_\_\_
17. Alert event record entries \_\_\_\_\_
18. Export ValveLink data (if available) for the device (Status Monitor, Detailed Setup, etc.).

### Mounting

1. Which digital valve controller do you have?  
DVC6200 \_\_\_\_\_ DVC6205/DVC6215 \_\_\_\_\_
2. What Make, Brand, Style, Size, etc. actuator is the DVC6200 mounted on? \_\_\_\_\_
3. What is the full travel of the valve? \_\_\_\_\_
4. What is the Mounting Kit part number? \_\_\_\_\_
5. If mounting kits are made by Impact Partner/Customer, please provide pictures of installation.
6. Is the Mounting kit installed per the instructions? Yes \_\_\_\_\_ No \_\_\_\_\_
7. What is the safe position of the valve? Fail closed \_\_\_\_\_ Fail open \_\_\_\_\_

## Section 7: Parts

### 7.1 Parts Ordering

Whenever corresponding with your Emerson sales office about this equipment, always mention the controller serial number.

#### **⚠ WARNING**

**Use only genuine Fisher replacement parts. Components that are not supplied by Emerson should not, under any circumstances, be used in any Fisher instrument. Use of components not supplied by Emerson may void your warranty, might adversely affect the performance of the instrument and could cause personal injury and property damage.**

### 7.2 Parts Kits

#### **NOTE**

All Standard kits with elastomers include nitrile elastomers. Extreme temperature kits include fluorosilicone elastomers.

Kit	Description	Part Number
1*	Elastomer Spare Parts Kit (kit service one digital valve controller) Standard Extreme Temperature	19B5402X012 19B5402X022
2*	Small Hardware Spare Parts Kit (kit contains parts to service one digital valve controller)	19B5403X032
3*	Seal Screen Kit [kit contains 25 seal screens (key 231) and 25 O-rings (key 39)]	14B5072X182
4*	Integral Mount Seal Kit (for 667 size 30i to 76i and GX actuators) [kit contains 5 seals (key 288)]	19B5402X032

Kit	Description	Part Number	
5*	Terminal Box Kit (see Figure 22) Use only with replace in-kind. The following terminal boxes are compatible only with PWB Assembly electronics hardware revision 2 (HW2).	---	
	Aluminum, without I/O Package Standard Standard, M20 Standard, Natural Gas Certified Standard, Natural Gas Certified, M20 Extreme Temperature Extreme Temperature, M20 Extreme Temperature, Natural Gas Certified Extreme Temperature, Natural Gas Certified, M20	19B5401X142 19B5401X342 19B5401X742 19B5401X772 19B5401X152 19B5401X352 19B5401X752 19B5401X782	
	Aluminum, with I/O Package Standard Standard, M20 Standard, Natural Gas Certified Standard, Natural Gas Certified, M20 Extreme Temperature Extreme Temperature, M20 Extreme Temperature, Natural Gas Certified Extreme Temperature, Natural Gas Certified, M20	19B5401X182 19B5401X392 19B5401X942 19B5401X972 19B5401X192 19B5401X402 19B5401X952 19B5401X982	
	Stainless Steel, without I/O Package Extreme Temperature Extreme Temperature, M20 Extreme Temperature, Natural Gas Certified Extreme Temperature, Natural Gas Certified, M20	19B5401X722 19B5401X732 19B5401X762 19B5401X792	
	Stainless Steel, with I/O Package Extreme Temperature Extreme Temperature, M20 Extreme Temperature, Natural Gas Certified Extreme Temperature, Natural Gas Certified, M20	19B5401X202 19B5401X412 19B5401X932 19B5401X962	
	Key	Description	Part Number
	50	PWB Assembly (HW2) (see Figures 23 and 25) for DVC6200 and DVC6205 The following PWB Assemblies are compatible only with the terminal boxes shown in Figure 22. Contact your Emerson sales office if a replacement PWB is needed.	---
		Hardware Revision 2 (HW2), without I/O Package For instrument level HC, For instrument level AD For instrument level PD For instrument level ODV	---
		Hardware Revision 2 (HW2), with I/O Package For instrument level HC For instrument level AD For instrument level PD For instrument level ODV	---

**Figure 22. Terminal Box**

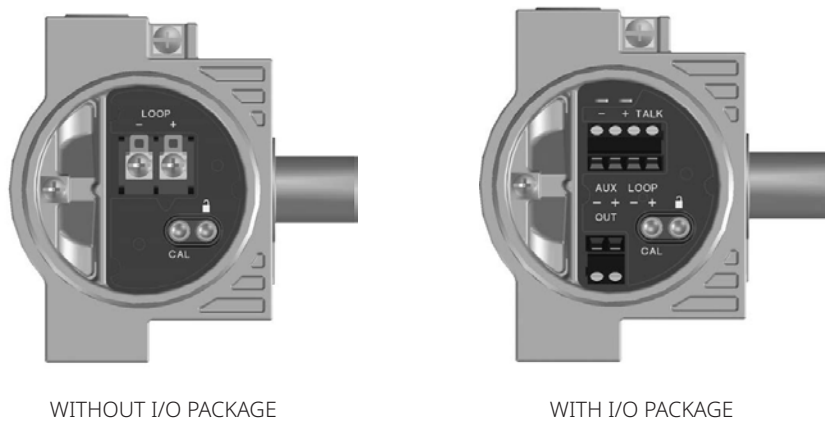

Kit	Description	Part Number
6*	I/P Converter Kit Standard Extreme Temperature	38B6041X152 38B6041X132
7*	Spare Module Base Assembly Kit, [kit contains module base (key 2); drive screws, qty. 2, (key 11); shield/label (key 19); hex socket cap screw, qty. 3, (key 38); self tapping screw, qty. 2 (key 49); pipe plug, qty. 3 (key 61); retaining ring, qty. 3 (key 154); screen (key 236); and flame arrestors, qty. 3 (key 243)] Aluminum Stainless Steel	GE18654X012 GE18654X022
8*	Spare Housing Assembly Kit, [kit contains housing (key 1); vent assembly (key 52); seal (only included in Housing A kits) (key 288); seal (key 237); O-ring (key 34); O-ring (only used with integrally mounted regulator) (key 5)] Aluminum Housing A (used for GX actuator) Standard Extreme Temperature Housing B (used for all actuators except GX) Standard Extreme Temperature Stainless Steel Housing B (used for all actuators except GX) Extreme Temperature	GE48798X032 GE48798X042 GE48798X072 GE48798X082 GE48798X102
9*	Spare I/P Shroud Kit [kit contains shroud (key 169) and hex socket cap screw, qty. 4 (key 23)]	GE29183X012
*Recommended spare parts		

Kit	Description	Part Number
10	Remote Mount Feedback Unit Kit (see Figure 26) [remote housing assembly (key 25); hex socket set screw (key 58); 1/2 NPT pipe plug (key 62); wire retainer, qty 2 (key 131); terminal cover (key 255); o-ring (key 256); gasket (Housing A only, used for GX actuator) (key 287); seal (Housing A only, used for GX actuator) (key 288)]	The Remote Mount Feedback Unit kit (kit 10) is not orderable by part number due to nameplate/approval requirements. Contact your Emerson sales office for information on ordering this kit.
11	<p>Feedback Array Kit</p> <p>Sliding Stem (Linear)</p> <p>[kit contains feedback array and hex socket cap screws, qty. 2, washer, plain, qty. 2, external tooth lock washer, qty. 2 (only with aluminum feedback array kit).</p> <p>210 mm / 8-1/4 in. kit contains feedback array and hex socket cap screws, qty. 4, washer, plain, qty. 4, external tooth lock washer, qty. 4 (only with aluminum feedback array kit) and insert]. Stainless steel kits only for use with stainless steel mounting kits.</p> <p>7 mm / 1/4-in.</p> <p>Aluminum Stainless Steel</p> <p>19 mm / 3/4-in.</p> <p>Aluminum Stainless steel</p> <p>25 mm / 1-in.</p> <p>Aluminum Stainless steel</p> <p>38 mm / 1-1/2 in.</p> <p>Aluminum Stainless steel</p> <p>50 mm / 2-in.</p> <p>Aluminum Stainless steel</p> <p>110 mm / 4-1/8 in.</p> <p>Aluminum Stainless steel</p> <p>210 mm / 8-1/4 in.</p> <p>Aluminum Stainless steel</p>	<p>GG20240X012 GE65853X082</p> <p>GG20240X022 GE65853X012</p> <p>GG20240X032 GE65853X022</p> <p>GG20240X042 GE65853X032</p> <p>GG20240X052 GE65853X042</p> <p>GG20240X082 GE65853X062</p> <p>GG20243X012 GE65853X072</p>
	<p>Rotary Array Kit with Pointer and Scale</p> <p>[Kit contains feedback assembly, pointer assembly, travel indicator scale and M3 machine pan head screws qty. 2]. Stainless steel kits only for use with stainless steel mounting kits.</p> <p>Aluminum Stainless steel</p>	<p>GG10562X012 GG10562X022</p>

- continued -

Kit	Description	Part Number
11	Rotary Array Kit with Coupler [Kit contains feedback assembly, NAMUR coupler, M3 machine pan head screws qty. 2 and cap screw qty. 1] Aluminum Stainless steel	GE71982X012 GE71982X022
	Rotary Array Kit with Beacon [Kit contains feedback assembly, beacon visual on/off indicator, indicator cover assembly, M3 machine pan head screws qty. 2 and M6 cap screws qty. 4] Aluminum Stainless steel	GH19538X012 GH19538X022
12	Mounting Shield Kit [kit contains shield, qty. 3 and machine screws, qty. 6]	GG05242X022
13*	Gasket/Seal Kit, for use with GX actuator [kit contains insulating gasket (key 287) and seal (key 288)]	GE45468X012
14	Alignment Template For linear actuators (except GX)	GE43826X012
	For GX actuators	GE20586X012

## 7.3 Parts List

### NOTE

Parts with footnote numbers shown are available in parts kits; see footnote information at the bottom of the page.

Contact your [Emerson sales office](#) for Part Ordering information.

Standard parts with elastomers include nitrile elastomers. Extreme temperature parts include fluorosilicone elastomers.

### Housing (See Figures 23 and 25)

Key	Description	Key	Description
1	Housing <sup>(8)</sup>	249	Screw, hex head (4 req'd) (DVC6205 only)
11	Drive Screw (2 req'd) (DVC6205 only)	250	Spacer (4 req'd) (DVC6205 only)
20	Shield (DVC6205 only)	267	Standoff (2 req'd) (DVC6205 only)
52	Vent <sup>(2)</sup>	271	Screen <sup>(8)</sup>
74	Mounting Bracket (DVC6205 only)	287	Gasket, Housing A only (used for GX actuator) (DVC6200 only)
248	Screw, hex head (4 req'd) (DVC6205 only)	288	Seal (used for 667 size 30i to 76i and GX actuators) (DVC6200 only)

2. Available in the Small Hardware Spare Parts Kit.

8. Available in the Spare Housing Assembly Kit



### Common Parts (See Figures 23, 24 and 25)

Key	Description	Part Number
16*	O-ring <sup>(1)</sup> (3 req'd)	---
29	Warning label, for use only with LCIE hazardous area classifications	---
33	Mach Screw, pan head <sup>(2)</sup> (3 req'd)	---
38	Cap Screw, hex socket <sup>(2)(7)</sup> (3 req'd)	---
43*	Cover Assembly (includes cover screws) Standard Extreme temperature	GG53748X012 GG53748X022
48	Nameplate	---
49	Screw, self tapping (2 req'd) <sup>(7)</sup>	---
61	Pipe Plug, hex socket <sup>(7)</sup> Housing A with relay C (2 req'd ) (used for GX actuator) Housing A with relay B (1 req'd) (used for GX actuator) Housing B with relay B and C (1 req'd) (used for all actuators except GX) Not required for relay A	---
63	Lithium grease (not furnished with the instrument)	---
64	Pipe thread sealant, anaerobic (not furnished with the instrument)	---
65	Lubricant, silicone sealant (not furnished with the instrument)	---
154	Retaining Ring <sup>(2)</sup> (3 req'd)	---
236	Screen (required for relay B and C only) <sup>(8)</sup>	---
237	Module Base Seal <sup>(1)</sup>	---
<p>*Recommended spare parts</p> <ol style="list-style-type: none"> <li>1. Available in the Elastomer Spare Parts Kit</li> <li>2. Available in the Small Hardware Spare Parts Kit</li> <li>7. Available in the Spare Module Base Assembly Kit</li> <li>8. Available in the Spare Housing Assembly Kit</li> </ol>		

### Module Base (See Figures 23 and 25)

Key	Description
2	Module Base <sup>(7)</sup>
11	Drive Screw <sup>(7)</sup> (2 req'd)
12	O-ring <sup>(1)</sup>
19	Shield <sup>(7)</sup>
61	Pipe Plug, hex socket <sup>(7)</sup> (3 req'd)
243	Slotted Pin (flame arrestor) <sup>(7)</sup> (3 req'd)
<ol style="list-style-type: none"> <li>1. Available in the Elastomer Spare Parts Kit</li> <li>7. Available in the Spare Module Base Assembly Kit</li> </ol>	

### I/P Converter Assembly (See Figures 23 and 25)

Key	Description
23	Cap Screw, hex socket <sup>(2)(9)</sup> (4 req'd)
39*	O-ring <sup>(1)(3)(6)</sup>
41	I/P Converter <sup>(6)</sup>
169	Shroud <sup>(6)(9)</sup> (see Figure 18)
210*	Boot <sup>(1)(6)</sup> (2 req'd) (see Figure 18)
231*	Seal Screen <sup>(1)(3)(6)</sup>
*Recommended spare parts 1. Available in the Elastomer Spare Parts Kit 2. Available in the Small Hardware Spare Parts Kit 3. Available in the Seal Screen Kit 6. Available in the I/P Converter Kit 9. Available in the Spare Shroud Kit	

### Relay (See Figures 23 and 25)

Key	Description	Part Number
24*	Standard	
	Standard Bleed	
	Housing A (used for GX actuator)	
	Single-acting direct (relay C)	38B5786X982
	Single-acting reverse (relay B)	38B5786X972
	Housing B (used for all actuators except GX)	
	Single-acting direct (relay C)	38B5786X932
	Double-acting (relay A)	38B5786X852
	Single-acting reverse (relay B)	38B5786X892
	Low Bleed	
	Housing A (used for GX actuator)	
	Single-acting direct (relay C)	38B5786X302
	Single-acting reverse (relay B)	38B5786X992
	Housing B (used for all actuators except G)	
	Single-acting direct (relay C)	38B5786X952
	Double-acting (relay A)	38B5786X872
	Single-acting reverse (relay B)	38B5786X912
	Extreme Temperature	
Standard Bleed		
Single-acting direct (relay C)	38B5786X942	
Double-acting (relay A)	38B5786X832	
Single-acting reverse (relay B)	38B5786X902	
Low Bleed		
Single-acting direct (relay C)	38B5786X962	
Double-acting (relay A)	38B5786X882	
Single-acting reverse (relay B)	38B5786X922	
*Recommended spare parts		

### Loop Connections Terminal Box (See Figures 23 and 25)

Key	Description
4	Terminal Box Cap
34*	O-ring <sup>(1)(5)</sup>
36*	O-ring <sup>(1)(5)</sup>
58	Set Screw, hex socket <sup>(2)</sup>
72	Cap Screw, hex socket <sup>(2)</sup>
164	Terminal Box Assembly
*Recommended spare parts 1. Available in the Elastomer Spare Parts Kit 2. Available in the Small Hardware Spare Parts Kit 5. Available in the Terminal Box Kit	

### Feedback Connections Terminal Box (See Figure 25) DVC6205 only

Key	Description
4	Terminal Box Cap
34*	O-ring <sup>(1)(5)</sup>
36*	O-ring <sup>(1)(5)</sup>
58	Set Screw, hex socket <sup>(2)</sup>
62	Pipe Plug, hex hd
262	Adapter
263*	O-ring
*Recommended spare parts 1. Available in the Elastomer Spare Parts Kit 2. Available in the Small Hardware Spare Parts Kit 5. Available in the Terminal Box Kit	

## Pressure Gauges, Pipe Plugs or Tire Valve Assemblies (See Figure 24)

Key	Description
47*	Pressure Gauge Double-acting (3 req'd); Single-acting (2 req'd) PSI/MPa Gauge Scale To 60 PSI, 0.4 MPa To 160 PSI, 1.1 MPa PSI/bar Gauge Scale To 60 PSI, 4 bar To 160 PSI, 11 bar PSI/KG/CM2 Gauge Scale To 60 PSI, 4 Kg/cm <sup>2</sup> To 160 PSI, 11 Kg/cm <sup>2</sup>
66	Pipe Plug, hex head For units without gauges
67	Tire Valve, used with Tire Valve Option only Double-acting (3 req'd); Single-acting (2 req'd)
*Recommended spare parts	

## DVC6215 Feedback Unit (See Figure 26)

Key	Description
65	Lubricant, silicone sealant (not furnished with the instrument)
256*	O-ring
*Recommended spare parts	

## HART Filters

Key	Description
- - -	HF340, DIN rail mount
- - -	HF341, DIN rail Mount, pass through (no filter)

Figure 23. FIELDVUE DVC6200 Digital Valve Controller Housing Assembly

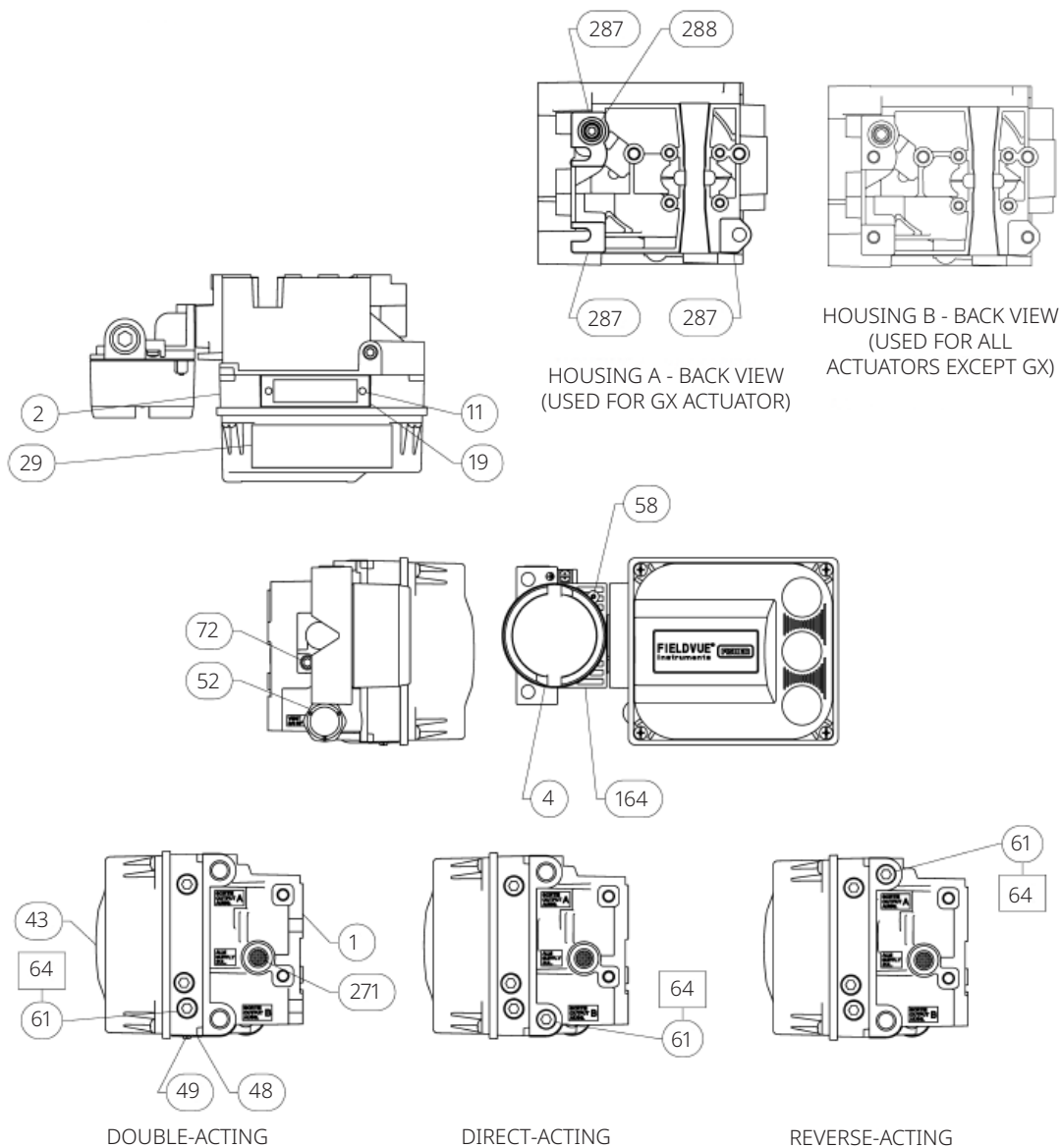

□ APPLY LUBRICANT, SEALANT OR THREAD LOCK

◼ APPLY LUBRICANT ON ALL O-RINGS UNLESS OTHERWISE SPECIFIED

GE40185 SHEET 1 OF 3

**Figure 23. FIELDVUE DVC6200 Digital Valve Controller Housing Assembly (continued)**

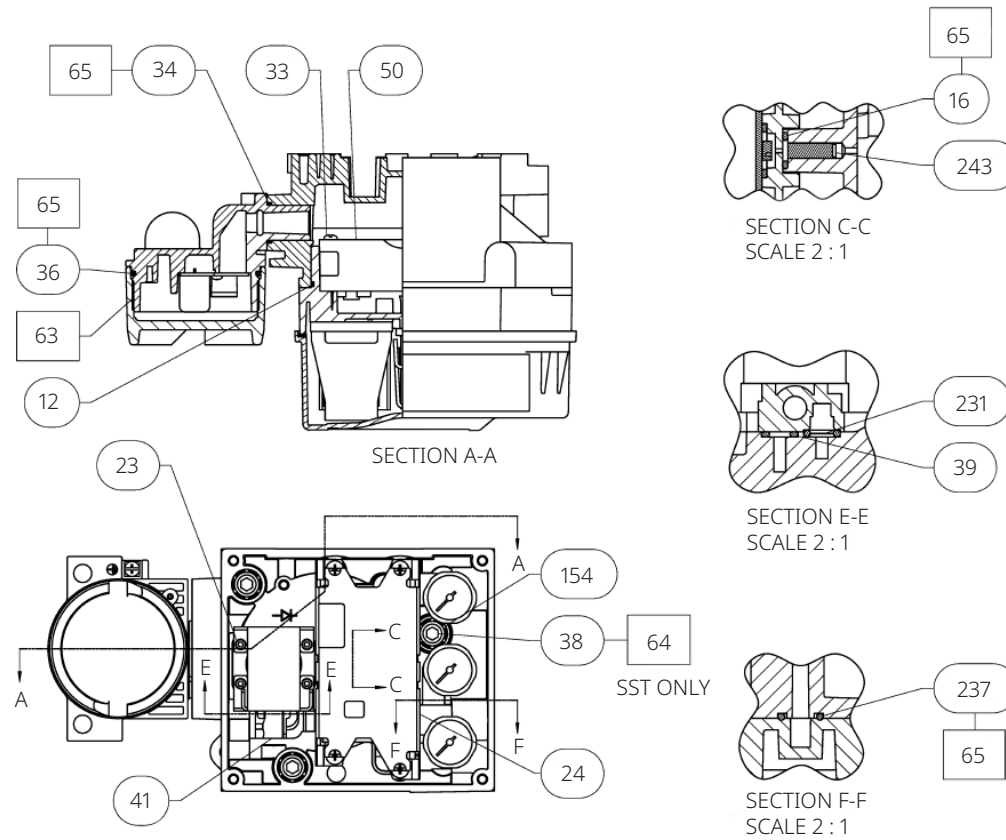

- APPLY LUBRICANT, SEALANT OR THREAD LOCK
- 65 APPLY LUBRICANT ON ALL O-RINGS UNLESS OTHERWISE SPECIFIED

GE40185 SHEET 2 of 3

**Figure 24. Gauge Configuration**

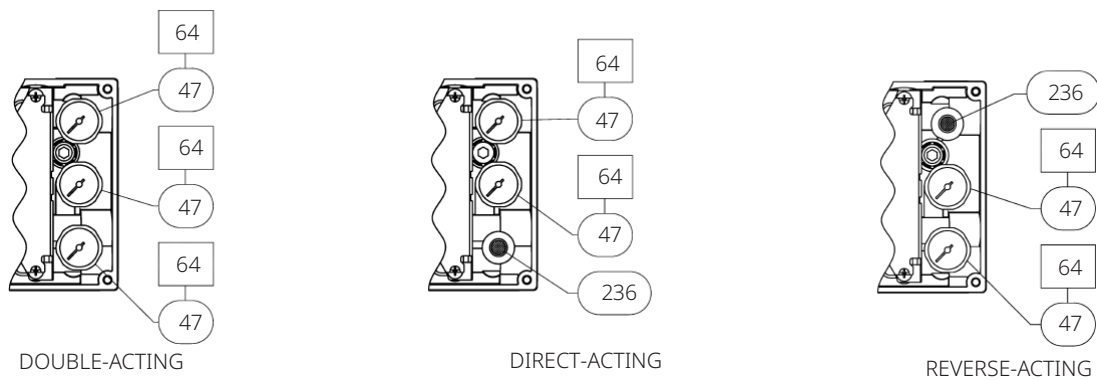

FOR PIPE PLUG OPTION REPLACE (47) WITH (66)

FOR TIRE VALVE OPTION REPLACE (47) WITH (67)

- APPLY LUBRICANT, SEALANT OR THREAD LOCK
- 65 APPLY LUBRICANT ON ALL O-RINGS UNLESS OTHERWISE SPECIFIED

GE40185 SHEET 3 of 3

Figure 25. FIELDVUE DVC6205 Base Unit Housing Assembly

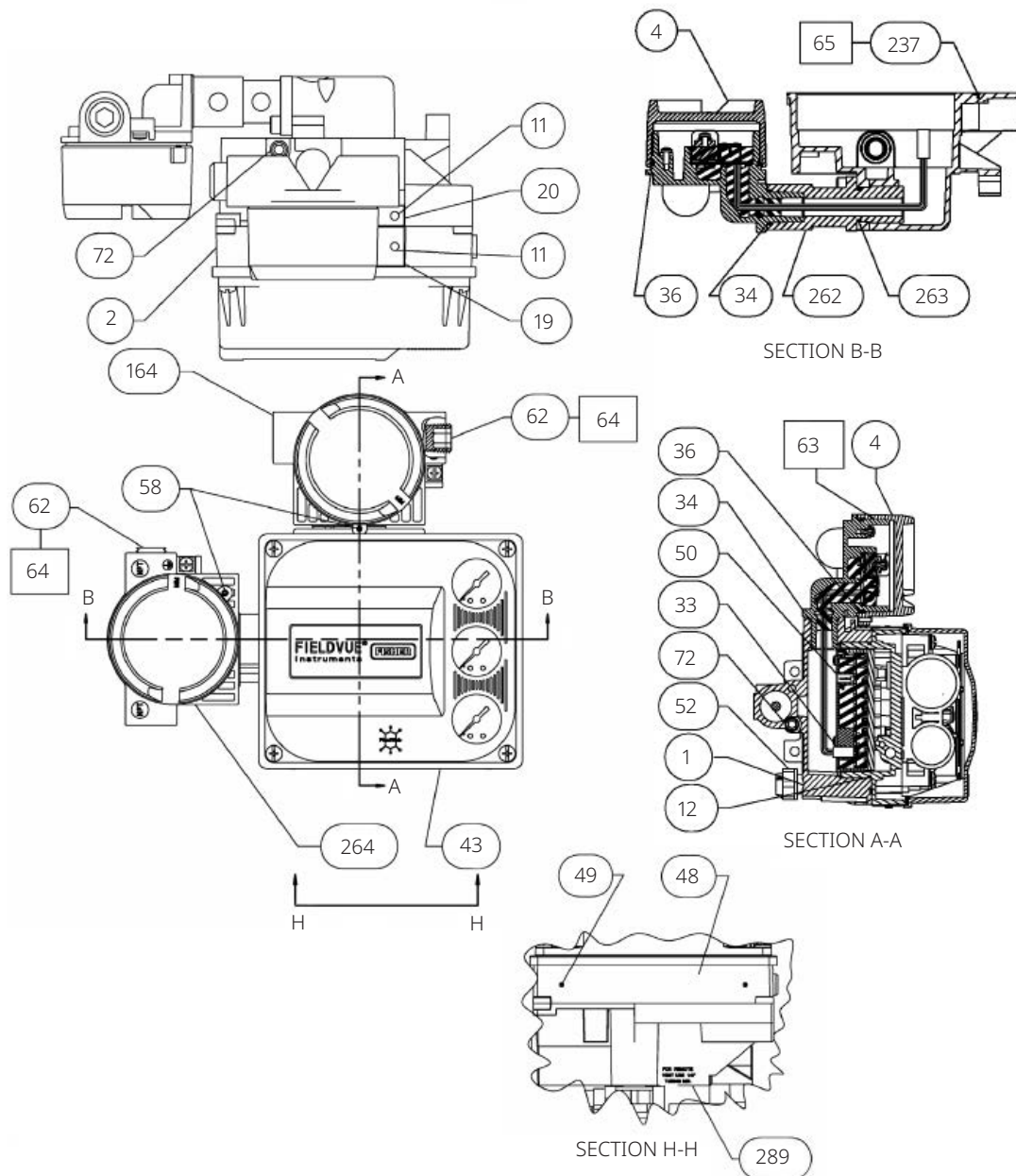

□ APPLY LUBRICANT, SEALANT OR THREAD LOCK

65 APPLY LUBRICANT ON ALL O-RINGS UNLESS OTHERWISE SPECIFIED

GE40181

Figure 25. FIELDVUE DVC6205 Base Unit Housing Assembly (continued)

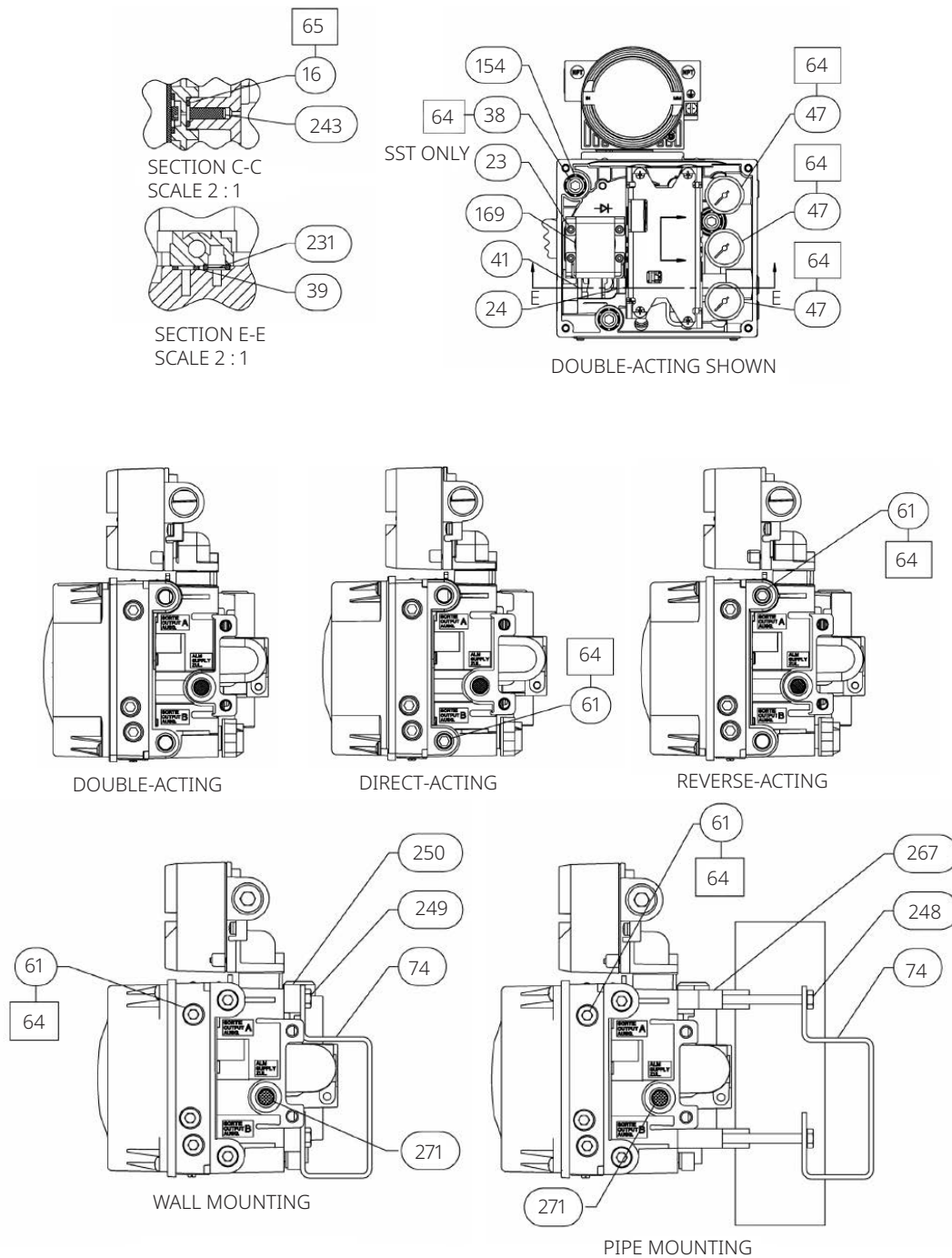

□ APPLY LUBRICANT, SEALANT OR THREAD LOCK

65 APPLY LUBRICANT ON ALL O-RINGS UNLESS OTHERWISE SPECIFIED

GE40181



**Figure 26. FIELDVUE DVC6215 Remote Feedback Assembly**

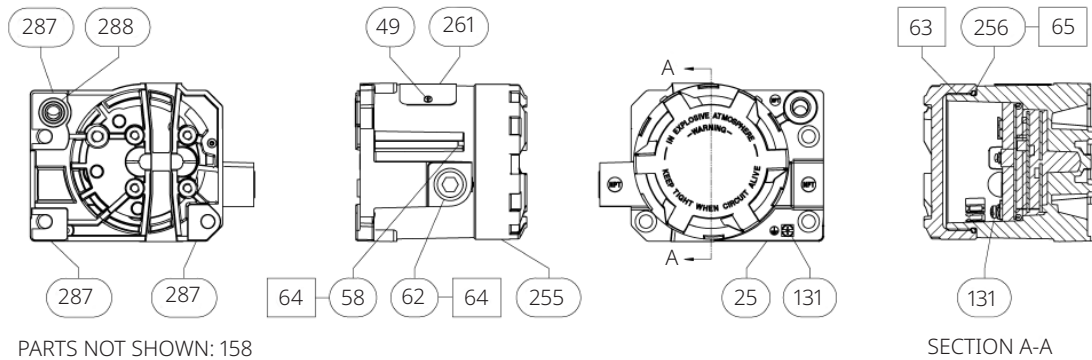

PARTS NOT SHOWN: 158

APPLY LUBRICANT/SEALANT

GE46670-B

HOUSING A  
(USED FOR GX ACTUATOR)

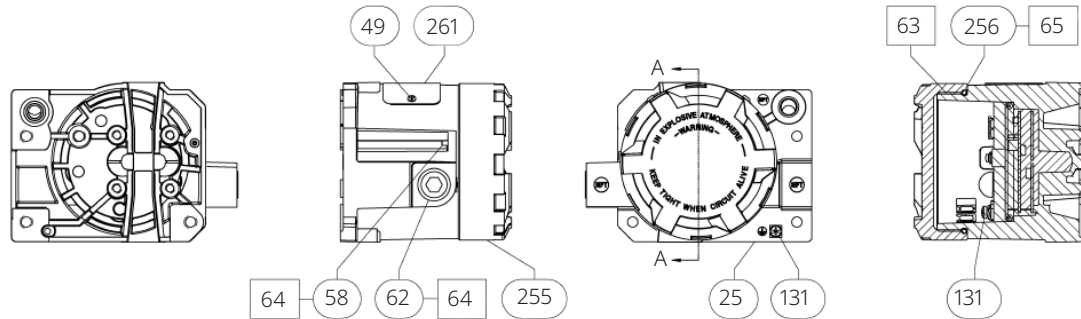

PARTS NOT SHOWN: 158

APPLY LUBRICANT/SEALANT

GE40178-B

HOUSING B  
(USED FOR ALL ACTUATORS EXCEPT GX)

# Appendix A: Principle of Operation

## A.1 HART Communication

The HART (Highway Addressable Remote Transducer) protocol gives field devices the capability of communicating instrument and process data digitally. This digital communication occurs over the same two-wire loop that provides the 4 to 20 mA process control signal, without disrupting the process signal. In this way, the analog process signal, with its faster update rate, can be used for control. At the same time, the HART protocol allows access to digital diagnostic, maintenance and additional process data. The protocol provides total system integration via a host device.

The HART protocol uses frequency shift keying (FSK). Two individual frequencies of 1200 and 2200 Hz are superimposed over the 4 to 20 mA current signal. These frequencies represent the digits 1 and 0 (see Figure A-1). By superimposing a frequency signal over the 4 to 20 mA current, digital communication is attained. The average value of the HART signal is zero, therefore no DC value is added to the 4 to 20 mA signal. Thus, true simultaneous communication is achieved without interrupting the process signal.

**Figure A-1. HART Frequency Shift Keying Technique**

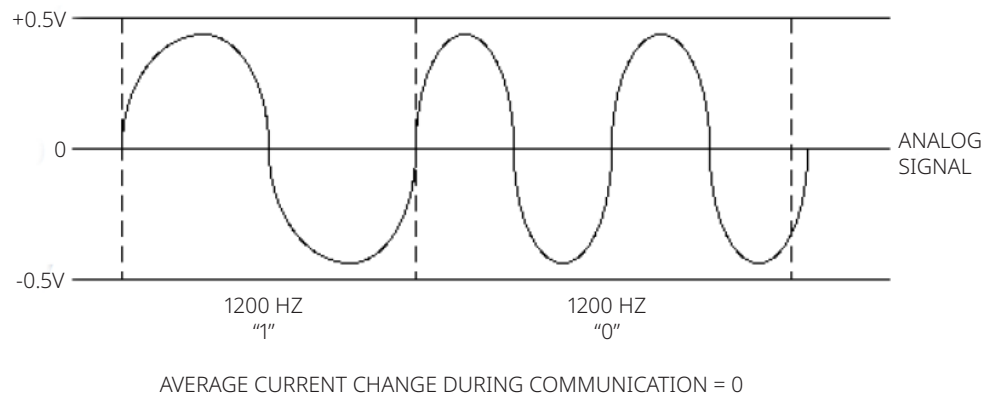

A6174

The HART protocol allows the capability of multidropping, i.e., networking several devices to a single communications line. This process is well suited for monitoring remote applications such as pipelines, custody transfer sites and tank farms. See Table 17 for instructions on changing the printed wiring board DIP switch configuration to multidrop.

## A.2 DVC6200 Digital Valve Controller

The DVC6200 digital valve controller housing contains the travel sensor, terminal box, pneumatic input and output connections and a module base that may be easily replaced in the field without disconnecting field wiring or tubing. The module base contains the following submodules: I/P converter, printed wiring board (pwb) assembly and pneumatic relay. The relay position is detected by sensing the magnet on the relay beam via a detector on the printed wiring board. This sensor is used for the minor loop feedback (MLFB) reading. The module base can be rebuilt by replacing the submodules. See Figures A-3, A-4, A-5 and A-6.

**Figure A-2. Typical FIELDVUE Instrument to Personal Computer Connections for ValveLink Software**

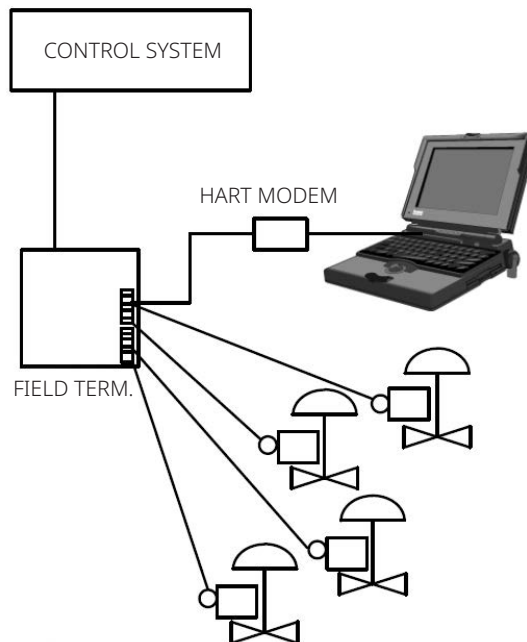

E1362

DVC6200 digital valve controllers are loop-powered instruments that provide a control valve position proportional to an input signal from the control room. The following describes a double-acting digital valve controller mounted on a piston actuator.

The input signal is routed into the terminal box through a single twisted pair of wires and then to the printed wiring board assembly submodule where it is read by the microprocessor, processed by a digital algorithm and converted into an analog I/P drive signal.

As the input signal increases, the drive signal to the I/P converter increases, increasing the I/P output pressure. The I/P output pressure is routed to the pneumatic relay submodule. The relay is also connected to supply pressure and amplifies the small pneumatic signal from the I/P converter. The relay accepts the amplified pneumatic signal and provides two output pressures. With increasing input (4 to 20 mA signal), the output A pressure always increases and the output B pressure decreases. The output A pressure is used for double-acting and single-acting direct applications. The output B pressure is used for double-acting and single-acting reverse applications. As shown in Figures A-3, A-4 and A-5, the increased output A pressure causes the actuator stem to move downward. Stem position is sensed by the non-contact travel feedback sensor. The stem continues to move downward until the correct stem position is attained. At this point, the printed wiring board assembly stabilizes the I/P drive signal. This positions the flapper to prevent any further increase in nozzle pressure.

As the input signal decreases, the drive signal to the I/P converter submodule decreases, decreasing the I/P output pressure. The pneumatic relay decreases the output A pressure and increases the output B pressure. The stem moves upward until the correct position is attained. At this point, the printed wiring board assembly stabilizes the I/P drive signal. This positions the flapper to prevent any further decrease in nozzle pressure.

**Figure A-3. FIELDVUE DVC6200 Digital Valve Controller Block Diagram**

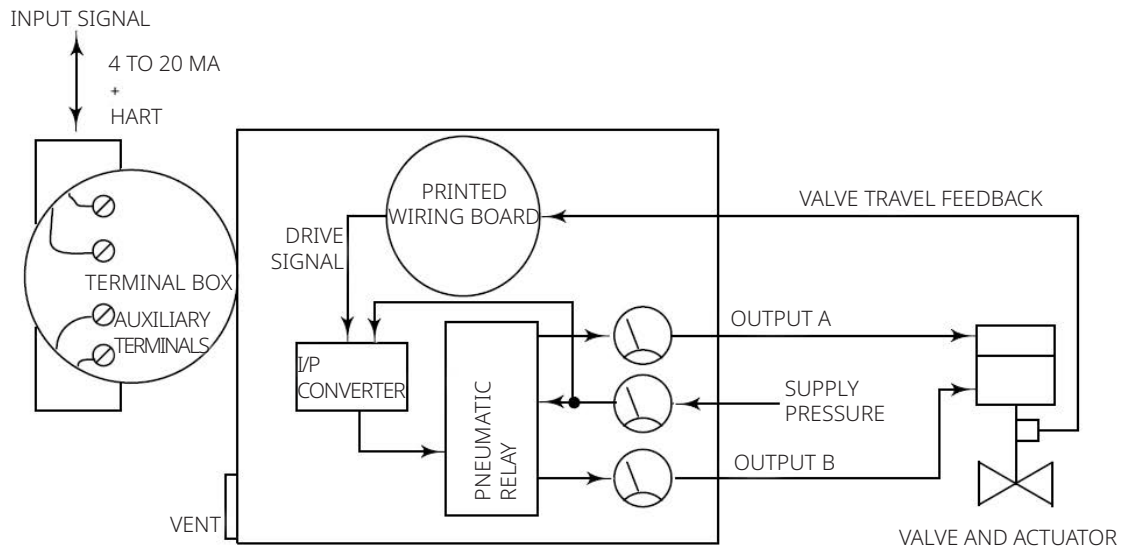

E1361

**Figure A-4. FIELDVUE DVC6200 Digital Valve Controller with Position Transmitter Block Diagram**

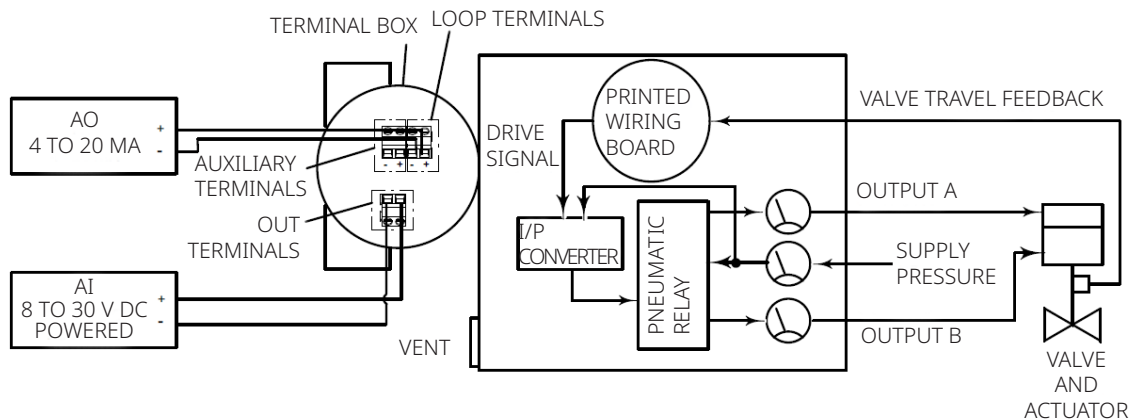

**Figure A-5. FIELDVUE DVC6200 Digital Valve Controller with Discrete Switch Block Diagram**

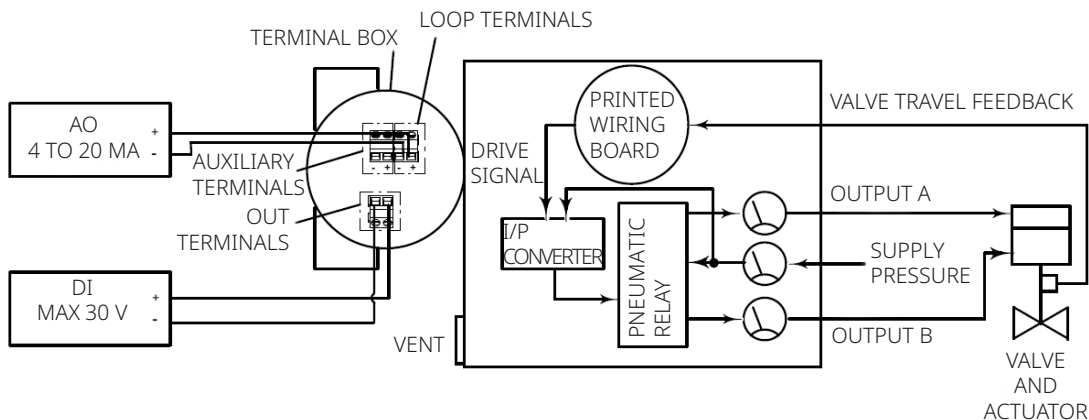

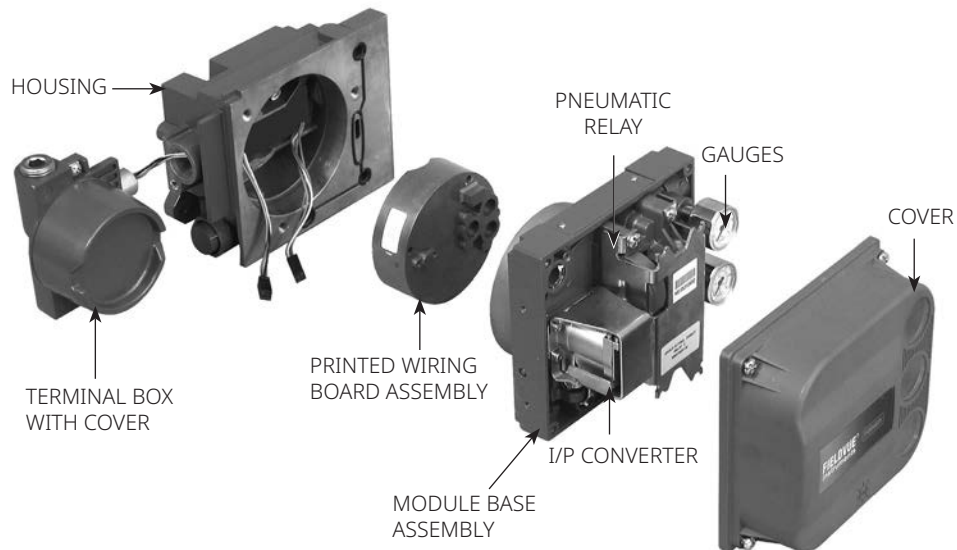
**Figure A-6. FIELDVUE DVC6200 Digital Valve Controller Assembly**

W9925-2

## Appendix B: Handheld Communicator Menu Trees

This section contains the handheld communicator menu trees for instrument level HC, AD, PD and ODV.

**Figure B-1. Hot Key****Favorites  
Hot Key**

- Instrument Mode
- Change Instrument Mode
- Write Protection
- Change Write Protection

**Figure B-2. Online HART Application**

Offline

Online

**Overview**

**Configure**

**Service Tools**

Utility

HART Diagnostics

**Figure B-3. Overview**

**Overview**

Device Status

Analog Input

Setpoint

Travel

Drive Signal

Pressure Variables

**Supply Pressure**

**Pressure A**

**Pressure B**

**Pressure A-B**

**Device Information**

**Identification**

HART Tag

HART Long Tag<sup>(2)</sup>

Manufacturer

Model

Instrument Level

Device ID and Serial Numbers

Device ID

Valve Serial Number

Instrument Serial Number

PWB Serial Number

Message

Description

**Revisions**

HART Universal Revision

Device Revision

Hardware Revision

Firmware Revision

DD Information

**Security**

Write Protection

Change Write Protection

NOTES:

1. SUPPLY PRESSURE IS AVAILABLE FOR INSTRUMENT LEVEL AD, PD AND ODV.

2. HART LONG TAG IS AVAILABLE WITH HART 7 ONLY.

**Figure B-4. Guided Setup and Manual Setup**

<p><b>Configure</b></p> <p>Guided Setup</p> <p><b>Device Setup</b></p> <p><b>Auto Calibration</b></p> <p>Manual Setup</p> <p><b>Mode and Protection</b></p> <p>Instrument Mode</p> <p>Change Instrument Mode</p> <p>Protection</p> <p>Change Write Protection</p> <p><b>Instrument</b></p> <p>Identification</p> <p>    HART Tag</p> <p>    HART Long Tag<sup>(1)</sup></p> <p>    Description</p> <p>    Message</p> <p>    Polling Address</p> <p>Serial Numbers</p> <p>    Instrument Serial Number</p> <p>    Valve Serial Number</p> <p>Units</p> <p>    Pressure Units</p> <p>    Temperature Units</p> <p>    Analog Input Units</p> <p>Terminal Box</p> <p>    Calibration Button</p> <p>    Auxiliary Terminal Action<sup>(2)</sup></p> <p>    Edit Auxiliary Terminal Action<sup>(2)</sup></p> <p>Analog Input Range</p> <p>    Input Range Hi</p> <p>    Input Range Lo</p>	<p>Spec Sheet</p> <p>Units</p> <p>    Travel Units</p> <p>    Length Units</p> <p>    Area Units</p> <p>    Spring Rate Units</p> <p>    Torque Units</p> <p>Valve</p> <p>    Valve Manufacturer</p> <p>    Valve Model</p> <p>    Valve Serial Number</p> <p>    Valve Style</p> <p>    Valve Style</p> <p>    Valve Size</p> <p>    Valve Class</p> <p>    Stem Diameter</p> <p>    Packing Type</p> <p>    Valve Travel</p> <p>        Rated Travel</p> <p>        Actual Travel</p> <p>Inlet/Outlet Pressures</p> <p>    Inlet Pressure</p> <p>    Outlet Pressure</p> <p>Torque<sup>(3)</sup></p> <p>    Dynamic Torque</p> <p>    Breakout Torque</p> <p>Trim</p> <p>    Seat Type</p> <p>    Leak Class</p> <p>    Port Diameter</p> <p>    Port Type</p> <p>    Flow Direction</p> <p>    Push Down To</p> <p>    Flow Tends To</p> <p>    Unbalanced Area</p>	<p>Actuator</p> <p>    Actuator Manufacturer</p> <p>    Actuator Model</p> <p>    Actuator Size</p> <p>    Actuator Selection</p> <p>Travel</p> <p>    Feedback Connection</p> <p>    Travel Sensor Motion</p> <p>Lever Style<sup>(3)</sup></p> <p>    Lever Style</p> <p>    Lever Arm Length</p> <p>Effective Area</p> <p>Spring Rate</p> <p>Air</p> <p>    Air</p> <p>    Upper Bench Set</p> <p>    Lower Bench Set</p> <p>    Nominal Supply</p> <p>Accessories</p> <p>    Volume Booster</p> <p>    Quick Release</p> <p>    Solenoid Valve</p> <p>    Position Transmitter</p> <p>    Limit Switch Valve Open</p> <p>    Limit Switch Valve Close</p> <p>Edit Instrument Time</p> <p><b>Travel/Pressure Control</b></p> <p>Travel/Pressure Select</p> <p>Change Travel/Pressure Select</p> <p>Cutoffs/Limits</p> <p>    Hi Limit/Cutoff Select</p> <p>    Hi Limit/Cutoff Point</p> <p>    Hi Soft Cutoff Rate</p> <p>    Lo Limit/Cutoff Select</p> <p>    Lo Limit/Cutoff Point</p> <p>    Lo Soft Cutoff Rate</p>
--	--	---

continued on next page

NOTES:

1. HART LONG TAG IS AVAILABLE WITH HART 7.
2. AUXILIARY TERMINAL ACTION AND EDIT AUXILIARY TERMINAL ACTION ARE AVAILABLE WITH INSTRUMENT LEVEL ODV.
3. AVAILABLE WHEN VALVE IS ROTARY.



**Figure B-4. Guided Setup and Manual Setup (continued)**

<p><b>Travel/Pressure Control (continued)</b></p> <ul style="list-style-type: none"> <li>Pressure Control             <ul style="list-style-type: none"> <li>Pressure Range High</li> <li>Pressure Range Low</li> </ul> </li> <li>Pressure Fallback<sup>(1)</sup> <ul style="list-style-type: none"> <li>Tvl Dev Press Fallback</li> <li>Tvl Dev Press Fallback Time</li> <li>Fallback Recovery</li> <li>Supply Pressure Lo Alert Point</li> </ul> </li> <li>Control Mode             <ul style="list-style-type: none"> <li>Control Mode</li> <li>Change Control Mode</li> <li>Restart Control Mode</li> </ul> </li> <li>Characterization             <ul style="list-style-type: none"> <li>Input Characterization</li> <li>Custom Characterization</li> </ul> </li> <li>Dynamic Response             <ul style="list-style-type: none"> <li>SP Rate Open</li> <li>SP Rate Close</li> <li>View/Edit Lag Time</li> </ul> </li> <li>Characterization             <ul style="list-style-type: none"> <li>Input Characterization</li> <li>Custom Characterization</li> </ul> </li> <li>Dynamic Response             <ul style="list-style-type: none"> <li>SP Rate Open</li> <li>SP Rate Close</li> <li>View/Edit Lag Time</li> </ul> </li> </ul> <p><b>Tuning</b></p> <ul style="list-style-type: none"> <li>Travel Tuning             <ul style="list-style-type: none"> <li>Travel Tuning Set</li> <li>Proportional Gain</li> <li>Velocity Gain</li> <li>MLFB Gain</li> <li>Integral Enable</li> <li>Integral Gain</li> <li>Stabilize/Optimize</li> </ul> </li> </ul>	<p><b>Tuning (continued)</b></p> <ul style="list-style-type: none"> <li>Pressure Tuning             <ul style="list-style-type: none"> <li>Pressure Tuning Set</li> <li>Proportional Gain</li> <li>MLFB Gain</li> <li>Integral Enable</li> <li>Integral Gain</li> </ul> </li> <li>Travel/Pressure Integral Settings             <ul style="list-style-type: none"> <li>Integral Dead Zone</li> <li>Integrator Limit</li> </ul> </li> </ul> <p><b>Valve and Actuator</b></p> <ul style="list-style-type: none"> <li>Valve Style</li> <li>Actuator Style</li> <li>Feedback Connection</li> <li>Relay Type</li> <li>Zero Power Condition</li> <li>Travel Sensor Motion</li> <li>Max Supply Pressure</li> </ul> <p><b>Partial Stroke<sup>(2)</sup></b></p> <ul style="list-style-type: none"> <li>Test Configuration             <ul style="list-style-type: none"> <li>PST Enable</li> <li>PST Start Point</li> <li>PST Variables</li> <li>Return Lead</li> <li>Short Duration PST</li> <li>Max Allowable Travel Movement</li> <li>Min Required Travel Movement</li> </ul> </li> <li>Test Acceptance Criteria             <ul style="list-style-type: none"> <li>Outgoing Pressure Threshold</li> <li>Incoming Pressure Threshold</li> <li>High Friction Breakout Press</li> <li>Low Friction Breakout Press</li> <li>Breakout Timeout</li> </ul> </li> <li>PST Alert Behavior             <ul style="list-style-type: none"> <li>PST Abnormal Criteria</li> <li>PST Abort Criteria</li> <li>PST Result Criticality</li> </ul> </li> <li>PST Deferral Reason</li> <li>Last PST results</li> </ul>	<p><b>Outputs (with I/O Package)</b></p> <ul style="list-style-type: none"> <li>Output Terminal Config             <ul style="list-style-type: none"> <li>Output Terminal Enable Function</li> <li>Fail Signal</li> </ul> </li> <li>Limit Switch Configuration             <ul style="list-style-type: none"> <li>Limit Switch Trip Point</li> <li>Switch Closed</li> </ul> </li> <li>Alert Switch Configuration             <ul style="list-style-type: none"> <li>Alert Switch Source</li> </ul> </li> <li>HART Var Assignments             <ul style="list-style-type: none"> <li>Primary Variable (PV)</li> <li>Secondary Variable (SV)</li> <li>Tertiary Variable (TV)</li> <li>Quaternary Variable (QV)</li> </ul> </li> <li>Transmitter Output</li> <li>Burst Mode             <ul style="list-style-type: none"> <li>Burst Enable</li> <li>View/Edit Burst Messages<sup>(3)</sup></li> </ul> </li> </ul> <p><b>Outputs (without I/O Package)</b></p> <ul style="list-style-type: none"> <li>HART Var Assignments             <ul style="list-style-type: none"> <li>Primary Variable (PV)</li> <li>Secondary Variable (SV)</li> <li>Tertiary Variable (TV)</li> <li>Quaternary Variable (QV)</li> </ul> </li> <li>Burst Mode             <ul style="list-style-type: none"> <li>Burst Enable</li> <li>View/Edit Burst Messages<sup>(3)</sup></li> </ul> </li> </ul> <p><a href="#">Alert Setup (see Figure B-5)</a></p> <p><a href="#">Calibration (see Figure B-6)</a></p>
--	--	---

NOTES:

1. PRESSURE FALLBACK IS AVAILABLE FOR INSTRUMENT LEVEL AD, PD, AND ODV.
2. PARTIAL STROKE IS AVAILABLE FOR INSTRUMENT LEVEL ODV.
3. LABEL IS 'BURST COMMAND' FOR HART 5.

**Figure B-5. Alert Setup****Configure**

Guided Setup (see Figure B-4)

Manual Setup (see Figure B-4)

**Alert Setup****Electronics**

Electronic Alerts Enable

Drive Signal

Shutdown Activated

Output Circuit Error<sup>(2)</sup>Electronic Alerts NE107<sup>(3)</sup>

Drive Current Failure

Drive Signal

Critical NVM Failure

Non-Critical NVM Failure

Flash Integrity Failure

Reference Voltage Failure

Shutdown Activated

Output Circuit Error<sup>(2)</sup>

Electronic Alerts Shutdown

Drive Current Failure Shutdown

Critical NVM Failure Shutdown

Non-Critical NVM Failure Shutdown

Flash Integrity Failure Shutdown

Reference Voltage Failure Shutdown

**Pressure**

Pressure Alerts Enable

Supply Pressure Hi

Supply Pressure Lo<sup>(1)</sup>

Pressure Deviation

Port A Overpressurized

Pressure Alert NE107<sup>(3)</sup>

Supply Pressure Hi

Supply Pressure Lo<sup>(1)</sup>

Pressure Deviation

Port A Overpressurized

**Pressure (continued)**

Supply Pressure

Supply Pressure Hi Alert Point

Supply Pressure Lo Alert Point

Pressure Deviation Alert Point

Pressure Deviation Time

Port A Pressure Limit

Output Pressure Limit Enable

**Travel**

Travel Alerts Enable

Tvl Deviation

Tvl Hi Hi

Tvl Lo Lo

Tvl Hi

Tvl Lo

Tvl Limit/Cutoff Hi

Tvl Limit/Cutoff Lo

Travel Alerts NE107<sup>(3)</sup>

Travel Deviation

Travel Hi Hi

Travel Lo Lo

Travel Hi

Travel Lo

Travel Limit/Cutoff Hi

Travel Limit/Cutoff Lo

Travel

Setpoint

Travel Alert DB

Travel Deviation

Travel Deviation

Travel Deviation Alert Point

Travel Deviation Time

Travel Limit

Travel Hi Hi Alert Point

Travel Lo Lo Alert Point

Travel Hi Alert Point

Travel Lo Alert Point

**Travel (continued)**

Travel Limit/Cutoff

Hi Limit/Cutoff Point

Lo Limit/Cutoff Point

**Travel History**

Travel History Alerts Enable

Cycle Count Hi

Tvl Accum Hi

Travel History Alerts NE107<sup>(3)</sup>

Cycle Count High

Travel Accumulator High

Cycle Count/Travel Accum  
Deadband

Cycle Counter

Cycle Count

Edit Cycle Counts

Cycle Count High Alert Point

Travel Accumulator

Travel Accumulator

Edit Travel Accumulator

Travel Accumulator Alert Point

## NOTES:

1. SUPPLY PRESSURE LO ALERT IS AVAILABLE FOR INSTRUMENT LEVEL AD, PD, AND ODV.
2. OUTPUT CIRCUIT ERROR IS AVAILABLE WHEN THE TRANSMITTER FUNCTION IS CONFIGURED
3. NE107 ALERTS ARE AVAILABLE FOR HART 7.

**Figure B-5. Alert Setup (continued)**

**Partial Stroke<sup>(1)</sup>**

Partial Stroke Alerts Enable

PST Abnormal

PST Pass

PST Prohibited

Partial Stroke Alerts NE107<sup>(3)</sup>

PST Abnormal

PST Pass

PST Prohibited

Program Flow Failure

Partial Stroke Alerts Shutdown

Program Flow Failure Shutdown

PST Prohibited Alerts Enable

PST Prohibited Electronic Alerts

Critical NVM Failure

Drive Current Failure

Reference Voltage Failure

Minor Loop Sensor Failure

Flash Integrity Failure

Travel Sensor Failure

Pressure Sensor Failure

Temp Sensor Failure

Pressure Fallback Active

Supply Pressure Lo

Travel Deviation

**Sensors**

Sensor Alerts Enable

Pressure Fallback Active<sup>(2)</sup>

Sensor Alerts NE107<sup>(3)</sup>

Travel Sensor Failure

Pressure Sensor Failure

Temp Sensor Failure

Minor Loop Sensor Failure

Pressure Fallback Active<sup>(2)</sup>

Sensor Alerts Shutdown

Travel Sensor Failure Shutdown

Pressure Sensor Failure Shutdown

Temp Sensor Failure Shutdown

Minor Loop Sensor Failure Shutdown

**Sensors (continued)**

Change Travel/Pressure Select<sup>(2)</sup>

Travel Control

Pressure Control

Fallback-Sensor Failure

Fallback-Sensor/Tvl Deviation

Travel/Pressure Select<sup>(2)</sup>

Fallback Recover<sup>(2)</sup>

**Alert Record/Status**

Alert Record/Status Alerts Enable

Alert Record Not Empty

Alert Record Full

Instrument Time is Approximate

Calibration in Progress

Autocal in Progress

Diagnostic in Progress

Diagnostic Data Avail

Integrator Sat Hi

Integrator Sat Lo

Alert Record/Status Alerts NE107<sup>(3)</sup>

Alert Record Not Empty

Alert Record Full

Instrument Time is Approximate

Calibration in Progress

Autocal in Progress

Diagnostic in Progress

Diagnostic Data Avail

Integrator Sat Hi

Integrator Sat Lo

View Alert Records

Clear Records

Instrument Alert Record

Edit Instrument Time

**Calibration (see Figure B-6)**

NOTES:

1. PARTIAL STROKE IS AVAILABLE FOR INSTRUMENT LEVEL ODV.

2. PRESSURE FALLBACK MENU ITEMS ARE AVAILABLE FOR INSTRUMENT LEVEL AD, PD, AND ODV.

3. NE107 ALERTS ARE AVAILABLE FOR HART 7.

**Figure B-6. Calibration**

**Configure**

Guided Setup (see Figure B-4)

Manual Setup (see Figure B-4)

Alert Setup (see Figure B-5)

**Calibration**

**Travel Calibration (HART 5)**

Auto Calibration

Last AutoCal Status

Manual Calibration

Calibration Record)

**Travel Calibration (HART 7)**

Auto Calibration

Last AutoCal Status

Manual Calibration

Calibration Type

Calibration Time

Calibrator

**Relay Adjust**

**Sensor Calibration**

Pressures Sensors

Analog Input<sup>(1)</sup>

**PST Calibration<sup>(2)</sup>**

NOTES:

1. ANALOG INPUT IS NOT AVAILABLE WHEN THE DIP SWITCH IS SET TO MULTI-DROP.

2. PST CALIBRATION IS AVAILABLE FOR INSTRUMENT LEVEL ODV.

---

**Figure B-7. Service Tools**

**Service Tools**

Device Status

Alert Record

**View Alert Records**

**Clear Records**

Diagnostics

**Stroke Valve**

**Partial Stroke Test<sup>(1)</sup>**

Variables

**Travel/Pressure**

Setpoint

Travel

Drive Signal

Pressure Variables

Supply Pressure<sup>(2)</sup>

Pressure A

Pressure B

Pressure A-B

Change Travel/Pressure Select

Travel/Pressure Select

Fallback Recovery<sup>(2)</sup>

**Control Mode**

Control Mode

Change Control Mode

Restart Control Mode

**Analog Input**

**Temperature**

**Travel Counts**

**Characterization**

Input Characterization

Custom Characterization

**Travel History**

Cycle Count

Travel Accumulator

**Run Time Extremes**

Maximum Recorded Temperature

Minimum Recorded Temperature

Days Powered Up

Number of Power Ups

Maintenance

**Stabilize/Optimize**

**Restart Processor**

**Reset PST Abnormal Alert<sup>(3)</sup>**

**Change to HART 5<sup>(4)</sup>**

Simulate<sup>(5)</sup>

NOTES:

1. PARTIAL STROKE TEST IS AVAILABLE IN INSTRUMENT LEVEL ODV.
2. SUPPLY PRESSURE AND FALLBACK RECOVERY ARE AVAILABLE FOR AD, PD, ODV.
3. RESET PST ABNORMAL ALERT IS AVAILABLE IN INSTRUMENT LEVEL ODV.
4. LABEL IS 'CHANGE TO HART 7' FOR HART 5.
5. HART 7 ONLY.

# Glossary

**Alert Point**

An adjustable value that, when exceeded, activates an alert.

**Algorithm**

A set of logical steps to solve a problem or accomplish a task. A computer program contains one or more algorithms.

**Alphanumeric**

Consisting of letters and numbers.

**Analog Input Units**

Units in which the analog input is displayed and maintained in the instrument.

**ANSI (acronym)**

The acronym ANSI stands for the American National Standards Institute.

**ANSI Class**

Valve pressure/temperature rating.

**Bench Set**

Pressure, supplied to an actuator, required to drive the actuator through rated valve travel. Expressed in pounds per square inch.

**Byte**

A unit of binary digits (bits). A byte consists of eight bits.

**Calibration Location**

Where the instrument was last calibrated; either in the factory or in the field.

**Configuration**

Stored instructions and operating parameters for a FIELDVUE Instrument.

**Control Loop**

An arrangement of physical and electronic components for process control. The electronic components of the loop continuously measure one or more aspects of the process, then alter those aspects as necessary to achieve a desired process condition. A simple control loop measures only one variable. More sophisticated control loops measure many variables and maintain specified relationships among those variables.

**Control Mode**

Defines where the instrument reads its set point. The following control modes are available for a FIELDVUE Instrument:

**Analog** The instrument receives its travel set point over the 4 to 20 mA loop.

**Digital** The instrument receives its set point digitally, via the HART communications link.

**Test** This is not a user-selectable mode. The handheld communicator or ValveLink software places the instrument in this mode whenever it needs to move the valve, such as for calibration or diagnostic tests.

**Control Mode, Restart**

Determines the instrument control mode after a restart. See Control Mode for the available restart control modes.

**Controller**

A device that operates automatically to regulate a controlled variable.

**Current-to-Pressure (I/P) Converter**

An electronic component or device that converts a milliamp signal to a proportional pneumatic pressure output signal.

**Cycle Counter**

The capability of a FIELDVUE instrument to record the number of times the travel changes direction. The change in direction must occur after the deadband has been exceeded before it can be counted as a cycle.

**Cycle Counter Alert**

Checks the difference between the Cycle Counter and the Cycle Counter Alert Point. Cycle Counter Alert is active when the cycle counter value exceeds the Cycle Counter Alert Point. It clears after you reset the Cycle Counter to a value less than the alert point.

**Cycle Counter Alert Point**

An adjustable value which, when exceeded activates the Cycle Counter Alert. Valid entries are 0 to 4 billion cycles.

### Cycle Counter Deadband

Region around the travel reference point, in percent of ranged travel, established at the last increment of the Cycle Counter. The deadband must be exceeded before a change in travel can be counted as a cycle. Valid entries are 0% to 100%. Typical value is between 2% and 5%.

### Deviation

Usually, the difference between set point and process variable. More generally, any departure from a desired or expected value or pattern.

### Device ID

Unique identifier embedded in the instrument at the factory.

### Device Revision

Revision number of the interface software that permits communication between the handheld communicator and the instrument.

### Drive Signal

The signal to the I/P converter from the printed wiring board. It is the percentage of the total microprocessor effort needed to drive the valve fully open.

### Drive Signal Alert

Checks the drive signal and calibrated travel. If one of the following conditions exists for more than 20 seconds, the Drive Signal Alert is active. If none of the conditions exist, the alert is cleared.

#### If Zero Power Condition = Closed

The alert is active when:

drive signal <10% and calibrated travel >3%  
drive signal >90% and calibrated travel <97%

#### If Zero Power Condition = Open

The alert is active when:

drive signal <10% and calibrated travel <97%  
drive signal >90% and calibrated travel >3%

### Equal Percentage

A valve flow characteristic where equal increments of valve stem travel produce equal percentage changes in existing flow. One of the input characteristics available for a FIELDVUE Instrument. See also, Linear and Quick Opening.

### Feedback Signal

Indicates to the instrument the actual position of the valve. The travel sensor provides the feedback signal to the instrument printed wiring board assembly.

### Firmware Revision

The revision number of the instrument firmware. Firmware is a program that is entered into the instrument at time of manufacture and cannot be changed by the user.

### Free Time

Percent of time that the microprocessor is idle. A typical value is 25%. The actual value depends on the number of functions in the instrument that are enabled and on the amount of communication currently in progress.

### Full Ranged Travel

Current, in mA, that corresponds with the point where ranged travel is maximum, i.e., limited by the mechanical travel stops.

### Gain

The ratio of output change to input change.

### Hardware Revision

Revision number of the Fisher instrument hardware. The physical components of the instrument are defined as the hardware.

### HART (acronym)

The acronym HART stands for Highway Addressable Remote Transducer.

### HART Universal Revision

Revision number of the HART Universal Commands which are the communications protocol for the instrument.

### Input Characteristic

The relationship between the ranged travel and ranged input. Possible values include: linear, equal percentage and quick opening.

**Input Current**

The current signal from the control system that serves as the analog input to the instrument. See also Input Signal.

**Input Range**

The analog input signal range that corresponds to the travel range.

**Input Signal**

The current signal from the control system. The input signal can be displayed in milliamperes or in percent of ranged input.

**Instrument Level**

Determines the functions available for the instrument. See Table 13.

**Instrument Mode**

Determines if the instrument responds to its analog input signal. There are two instrument modes:

**In Service:** For a fully functioning instrument, the instrument output changes in response to analog input changes. Typically changes to setup or calibration cannot be made when the instrument mode is In Service.

**Out of Service:** The instrument output does not change in response to analog input changes when the instrument mode is Out of Service. Some setup parameters can be changed only when the instrument mode is Out of Service.

**Instrument Protection**

Determines if commands from a HART device can calibrate and/or configure certain parameters in the instrument. There are two types of instrument protection:

Configuration and Calibration: Prohibits changing protected setup parameters; prohibits calibration.

None: Permits both configuration and calibration. The instrument is "unprotected."

**Instrument Serial Number**

The serial number assigned to the printed wiring board by the factory but can be changed during setup. The instrument serial number should match the serial number on the instrument nameplate.

**Leak Class**

Defines the allowable leakage by a valve when it is closed. Leak class numbers are listed in two standards: ANSI/FCI 70-2 and IEC 534-4.

**Linear**

A valve flow characteristic where changes in flow rate are directly proportional to changes in valve stem travel. One of the input characteristics available for a FIELDVUE Instrument. See also, Equal Percentage and Quick Opening.

**Linearity, dynamic**

Linearity (independent) is the maximum deviation from a straight line best fit to the opening and closing curves and a line representing the average value of those curves.

**Memory**

A type of semiconductor used for storing programs or data. FIELDVUE instruments use three types of memory: Random Access Memory (RAM), Read Only Memory (ROM) and Non-Volatile Memory (NVM). See also these listings in this glossary.

**Menu**

A list of programs, commands, or other activities that you select by using the arrow keys to highlight the item then pressing ENTER, or by entering the numeric value of the menu item.

**Minimum Closing Time**

Minimum time, in seconds, for the travel to decrease through the entire ranged travel. This rate is applied to any travel decrease. Valid entries are 0 to 400 seconds. Deactivate by entering a value of 0 seconds.

**Minimum Opening Time**

Minimum time, in seconds, for the travel to increase through the entire ranged travel. This rate is applied to any travel increase. Because of friction, actual valve travel may not respond in exactly the same time frame. Valid entries are 0 to 400 seconds. Deactivate by entering a value of 0 seconds.



**Non-Volatile Memory (NVM)**

A type of semiconductor memory that retains its contents even though power is disconnected. NVM contents can be changed during configuration unlike ROM which can be changed only at time of instrument manufacture. NVM stores configuration restart data.

**Parallel**

Simultaneous: said of data transmission on two or more channels at the same time.

**Polling Address**

Address of the instrument. If the digital valve controller is used in a point-to-point configuration, set the polling address to 0. If it is used in a multidrop configuration, or split range application, set the polling address to a value from 0 to 15 for HART 5 and 0 to 63 for HART 7.

**Pressure Sensor**

A FIELDVUE instrument internal device that senses pneumatic pressure. The DVC6200 has three pressure sensors: one to sense supply pressure and two to sense the output pressures.

**Primary Master**

Masters are communicating devices. A primary master is a communicating device permanently wired to a field instrument. Typically, a HART-compatible control system or a computer running ValveLink software is the primary master.

In contrast, a secondary master is not often permanently wired to a field instrument. The handheld communicator or a computer running ValveLink software communicating through a HART modem could be considered a secondary master.

**Primary Master (continued)**

Note: If one type of master takes an instrument Out Of Service, the same type must put it In Service. For example, if a device set up as a primary master takes an instrument Out Of Service, a device set up as a primary master must be used to place the instrument In Service.

**Quick Opening**

A valve flow characteristic where most of the change in flow rate takes place for small amounts of stem travel from the closed position. The flow characteristic curve is basically linear through the first 40 percent of stem travel. One of the input characteristics available for a FIELDVUE Instrument. See also, Equal Percentage and Linear.

**Random Access Memory (RAM)**

A type of semiconductor memory that is normally used by the microprocessor during normal operation that permits rapid retrieval and storage of programs and data. See also Read Only Memory (ROM) and Non-Volatile Memory (NVM).

**Rate**

Amount of change in output proportional to the rate of change in input.

**Read-Only Memory (ROM)**

A memory in which information is stored at the time of instrument manufacture. You can examine but not change ROM contents.

**Seat Load**

Force exerted on the valve seat, typically expressed in pounds force per lineal inch of port circumference. Seat load is determined by shutoff requirements.

**Set Point Filter Time (Lag Time)**

The time constant, in seconds, for the first-order input filter. The default of 0 seconds will bypass the filter.

**Software**

Microprocessor or computer programs and routines that reside in alterable memory (usually RAM), as opposed to firmware, which consists of programs and routines that are programmed into memory (usually ROM) when the instrument is manufactured. Software can be manipulated during normal operation, firmware cannot.

**Stroking Time**

The time, in seconds, required to move the valve from its fully open position to fully closed, or vice versa.

**Temperature Sensor**

A device within the FIELDVUE instrument that measures the instrument's internal temperature.

**Travel**

Movement of the valve stem or shaft which changes the amount the valve is open or closed.

**Travel Accumulator**

The capability of a FIELDVUE instrument to record total change in travel. The value of the Travel Accumulator increments when the magnitude of the change exceeds the Travel Accumulator Deadband. To reset the Travel Accumulator, set it to zero.

**Travel Accumulator Alert**

Checks the difference between the Travel Accumulator value and the Travel Accumulator Alert Point. The Travel Accumulator Alert is active when the Travel Accumulator value exceeds the Travel Accumulator Alert Point. It clears after you reset the Travel Accumulator to a value less than the alert point.

**Travel Accumulator Alert Point**

An adjustable value which, when exceeded, activates the Travel Accumulator Alert. Valid entries are 0% to 4 billion %.

**Travel Accumulator Deadband**

Region around the travel reference point established at the last increment of the accumulator. This region must be exceeded before a change in travel can be accumulated. Valid entries are 0% to 100%.

**Travel Alert**

Checks the ranged travel against the travel high and low alert points. The travel alert is active if either the high or low point is exceeded. Once a high or low point is exceeded, the ranged travel must clear that point by the Travel Alert Deadband before the alert clears. Four travel alerts are available: Travel Alert Hi, Travel Alert Lo, Travel Alert Hi Hi and Travel Alert Lo Lo.

**Travel Alert Deadband**

Travel, in percent of ranged travel, required to clear a travel alert, once it is active. Valid entries are -25% to 125%.

**Travel Alert High Point**

Value of the travel, in percent of ranged travel, which, when exceeded, sets the Travel Alert Hi alert. Valid entries are -25% to 125%.

**Travel Alert High High Point**

Value of the travel, in percent of ranged travel, which, when exceeded, sets the Travel Alert Hi Hi alert. Valid entries are -25% to 125%.

**Travel Alert Low Point**

Value of the travel, in percent of ranged travel, which, when exceeded, sets the Travel Alert Lo alert. Valid entries are -25% to 125%.

**Travel Alert Low Low Point**

Value of the travel, in percent of ranged travel, which, when exceeded, sets the Travel Alert Lo Lo alert. Valid entries are -25% to 125%.

**Travel Cutoff**

Defines the cutoff point for the travel, in percent of ranged travel. There are two travel cutoffs: high and low. Once travel exceeds the cutoff, the drive signal is set to either maximum or minimum, depending on the Zero Control Signal and if the cutoff is high or low. Minimum opening time or minimum closing time are not in effect while the travel is beyond the cutoff. Use the travel cutoff to obtain the desired seat load or to be sure the valve is fully open.

**Travel Deviation**

The difference between the analog input signal (in percent of ranged input), the "target" travel and the actual "ranged" travel.

**Travel Deviation Alert**

Checks the difference between the target and the ranged travel. If the difference exceeds the Travel Deviation Alert Point for more than the Travel Deviation Time, the Travel Deviation Alert is active. It remains active until the difference is less than the Travel Deviation Alert Point.

**Travel Deviation Alert Point**

An adjustable value for the target travel and the ranged travel difference, expressed in percent. When this value is exceeded by the travel deviation for more than the Travel Deviation Time, the Travel Deviation Alert is active. Valid entries are 0% to 100%. Typically this is set to 5%.

**Travel Deviation Time**

The time, in seconds, that the travel deviation must exceed the Travel Deviation Alert Point before the alert is active. Valid entries are 1 to 60 seconds.

**Travel Limit**

A setup parameter that defines the maximum allowable travel (in percent of ranged travel) for the valve. During operation, the travel target will not exceed this limit. There are two travel limits: high and low. Typically the travel limit low will be used to keep the valve from going completely closed.

**Travel Range**

Travel, in percent of calibrated travel, that corresponds to the input range.

**Travel Sensor**

A device within the FIELDVUE instrument that senses valve stem or shaft movement. The travel sensor in the DVC6200 is the Hall Effect sensor that measures the position of the magnetic assembly.

**Travel Sensor Motion**

Increasing or decreasing air pressure causes the magnet assembly to move up or down or the rotary shaft to turn clockwise or counterclockwise. The Setup Wizard asks if it can move the valve to determine travel.

**Tuning**

The adjustment of control terms or parameter values to produce a desired control effect.

**Tuning Set**

Preset values that identify gain settings for a FIELDVUE instrument. The tuning set and supply pressure together determine an instrument's response to input signal changes.

**Watch Dog Timer**

A timer that the microprocessor must rearm periodically. If the microprocessor is unable to rearm the timer, the instrument goes through reset.

**Zero Power Condition**

The position of the valve (open or closed) when the electrical power to the instrument is removed. Zero Power Condition (ZPC) is determined by relay and actuator action as follows:

**Single-Acting Direct (Relay C)** Upon loss of electrical power instrument goes to zero air output at port A.

**Double-Acting (Relay A)** Upon loss of electrical power instrument goes to full supply air output at port B. A goes to zero air output.

**Single-Acting Reverse (Relay B)** Upon loss of electrical power instrument goes to full supply air output at Port B.

 Fisher.com

 Facebook.com/FisherValves

 LinkedIn.com/groups/3941826

 X.com/FisherValves

D103605X012 © 2012, 2024. Fisher Controls International LLC. All rights reserved.

**Neither Emerson, nor any of its affiliated entities assume responsibility for the selection, use or maintenance of any product. Responsibility for proper selection, use, and maintenance of any product remains solely with the purchaser and end user.**

Fisher, FIELDVUE, ValveLink, PROVOX, Rosemount, Tri-Loop, DeltaV, RS3, and THUM are marks owned by one of the companies in the Emerson Automation Solutions business unit of Emerson Electric Co. Emerson Automation Solutions, Emerson, and the Emerson logo are trademarks and service marks of Emerson Electric Co. HART is a registered trademark of FieldComm Group. All other marks are the property of their respective owners.

The contents of this publication are presented for informational purposes only, and while every effort has been made to ensure their accuracy, they are not to be construed as warranties or guarantees, express or implied, regarding the products or services described herein or their use or applicability. All sales are governed by our terms and conditions, which are available upon request. We reserve the right to modify or improve the designs or specifications of such products at any time without notice.

Emerson  
Marshalltown, Iowa 50158 USA  
Sorocaba, 18087 Brazil  
Cernay 68700 France  
Dubai, United Arab Emirates  
Singapore 128461 Singapore

[www.Fisher.com](http://www.Fisher.com)

**FISHER™**

  
**EMERSON**