

Micro Motion™ T-Series Coriolis Flow and Density Sensors



Safety messages

Safety messages are provided throughout this manual to protect personnel and equipment. Read each safety message carefully before proceeding to the next step.

Safety and approval information

This Micro Motion product complies with all applicable European directives when properly installed in accordance with the instructions in this manual. Refer to the EU Declaration of Conformity for directives that apply to this product. The following are available: the EU Declaration of Conformity, with all applicable European directives, and the complete ATEX installation drawings and instructions. In addition, the IECEx installation instructions for installations outside of the European Union and the CSA installation instructions for installations in North America are available at Emerson.com or through your local Micro Motion support center.

Information affixed to equipment that complies with the Pressure Equipment Directive, can be found at Emerson.com. For hazardous installations in Europe, refer to standard EN 60079-14 if national standards do not apply.

Other information

Troubleshooting information can be found in the appropriate Configuration and Use Manual. Product Data Sheets and Manuals are available from the Micro Motion website at Emerson.com.

Return policy

Follow Emerson procedures when returning equipment. These procedures ensure legal compliance with government transportation agencies and help provide a safe working environment for Emerson employees. If you fail to follow Emerson procedures, then Emerson will not accept your returned equipment.

Return procedures and forms are available on our web support site at Emerson.com, or by calling the Micro Motion Customer Service department.

Contents

Chapter 1	Before you begin.....	5
	1.1 About this document.....	5
	1.2 Hazard messages.....	5
	1.3 Related documentation.....	5
Chapter 2	Planning.....	7
	2.1 Installation checklist.....	7
	2.2 Best practices.....	7
	2.3 Temperature limits.....	8
	2.4 Recommendations for hygienic and self-draining applications.....	9
Chapter 3	Mounting.....	13
	3.1 Mount the sensor.....	13
	3.2 Attach extended electronics.....	13
	3.3 Rotate junction box or 800 core processor (optional).....	15
Chapter 4	Transmitter power and I/O wiring.....	17
	4.1 Options for wiring.....	17
	4.2 Connect 4-wire cable.....	18
	4.3 Connect the 9-wire cable	23
Chapter 5	Grounding.....	25
Chapter 6	Supplementary information.....	27
	6.1 Purge the sensor case	27

1 Before you begin

1.1 About this document

This document provides information on planning, mounting, wiring, and grounding the T-Series sensor.

The information in this document assumes that users understand basic transmitter and sensor installation, configuration, and maintenance concepts and procedures.

1.2 Hazard messages

This document uses the following criteria for hazard messages based on ANSI standards Z535.6-2011 (R2017).



DANGER
Serious injury or death will occur if a hazardous situation is not avoided.



WARNING
Serious injury or death could occur if a hazardous situation is not avoided.



CAUTION
Minor or moderate injury will or could occur if a hazardous situation is not avoided.

NOTICE

Data loss, property damage, hardware damage, or software damage can occur if a situation is not avoided. There is no credible risk of physical injury.

Physical access



WARNING
Unauthorized personnel can potentially cause significant damage and/or misconfiguration of end users' equipment. Protect against all intentional or unintentional unauthorized use.

Physical security is an important part of any security program and fundamental to protecting your system. Restrict physical access to protect users' assets. This is true for all systems used within the facility.

1.3 Related documentation

You can find all product documentation at [Emerson.com](https://www.emerson.com).

See any of the following documents for more information:

- The hazardous area approvals documentation shipped with the sensor or available at [Emerson.com/flowmeasurement](https://www.emerson.com/flowmeasurement).
- [Micro Motion T-Series Coriolis Flow and Density Meters Product Data Sheet](#)
- [Micro Motion 9-Wire Flowmeter Cable Preparation and Installation Manual](#)
- The transmitter installation guide and the transmitter configuration and use guide

2 Planning

2.1 Installation checklist

- Make sure that the hazardous area specified on the approval tag is suitable for the environment in which the meter will be installed.

 **WARNING**

Failure to abide by approvals can cause an explosion resulting in injury or death.

- Verify that the local ambient and process temperatures are within the limits of the meter.
- If your sensor has an integral transmitter, no wiring is required between the sensor and transmitter. Follow the wiring instructions in the transmitter installation manual for signal and power wiring.
- If your transmitter has remote-mounted electronics, follow the instructions in this manual for wiring between the sensor and the transmitter, and then follow the instructions in the transmitter installation manual for power and signal wiring.

Table 2-1: Maximum cable lengths

Cable type	To transmitter	Maximum length
Micro Motion 9-wire	9739 MVD and 5700 transmitter	1,000 ft (305 m)
	All other MVD transmitters	60 ft (18 m)
Micro Motion 4-wire	All 4-wire MVD transmitters	1,000 ft (305 m) without Ex-approval 500 ft (152 m) with IIC-rated sensors 1,000 ft (305 m) with IIB-rated sensors

Table 2-2: Maximum lengths for user-supplied 4-wire cable

Wire function	Wire size	Maximum length
Power (VDC)	22 AWG (0.326 mm ²)	300 ft (91 m)
	20 AWG (0.518 mm ²)	500 ft (152 m)
	18 AWG (0.823 mm ²)	1,000 ft (305 m)
Signal (RS-485)	22 AWG (0.326 mm ²) or larger	1,000 ft (305 m)

- For optimal performance, install the sensor in the preferred orientation. The sensor will work in any orientation as long as the flow tubes remain full of process fluid.
- Install the meter so that the flow direction arrow on the sensor case matches the actual forward flow of the process. (Flow direction is also software-selectable.)

2.2 Best practices

- There are no pipe run requirements for Micro Motion sensors. Straight runs of pipe upstream or downstream are unnecessary.

- If the sensor is installed in a vertical pipeline, liquids and slurries should flow upward through the sensor. Gases should flow downward.
- Keep the sensor tubes full of process fluid.
- For halting flow through the sensor with a single valve, install the valve downstream from the sensor.
- Minimize bending and torsional stress on the meter. Do not use the meter to align misaligned piping.
- The sensor does not require external supports. The flanges will support the sensor in any orientation.

2.3 Temperature limits

Sensors can be used in the process and ambient temperature ranges shown in the temperature limit graphs. For the purposes of selecting electronics options, temperature limit graphs should be used only as a general guide. If your process conditions are close to the gray area, consult with your Micro Motion representative.

WARNING

Temperature limits may be further restricted by hazardous area approvals that are necessary to avoid potential injury to personnel and damage to equipment. Refer to the hazardous area approvals documentation shipped with the sensor or available at [Emerson.com/flowmeasurement](https://www.emerson.com/flowmeasurement) for specific temperature ratings for each model and configuration.

Note

- In all cases, the electronics cannot be operated where the ambient temperature is below -40 °F (-40 °C) or above 140 °F (60 °C). If a sensor is to be used where the ambient temperature is outside of the range permissible for the electronics, the electronics must be remotely located where the ambient temperature is within the permissible range, as indicated by the shaded areas of the temperature limit graphs.
 - The extended-mount electronics option allows the sensor case to be insulated without covering the transmitter, core processor, or junction box, but does not affect temperature ratings. When insulating the sensor case at elevated process temperatures above 140 °F (60 °C), ensure electronics are not enclosed in insulation as this may lead to electronics failure.
-

Ambient and process temperature limits for all models

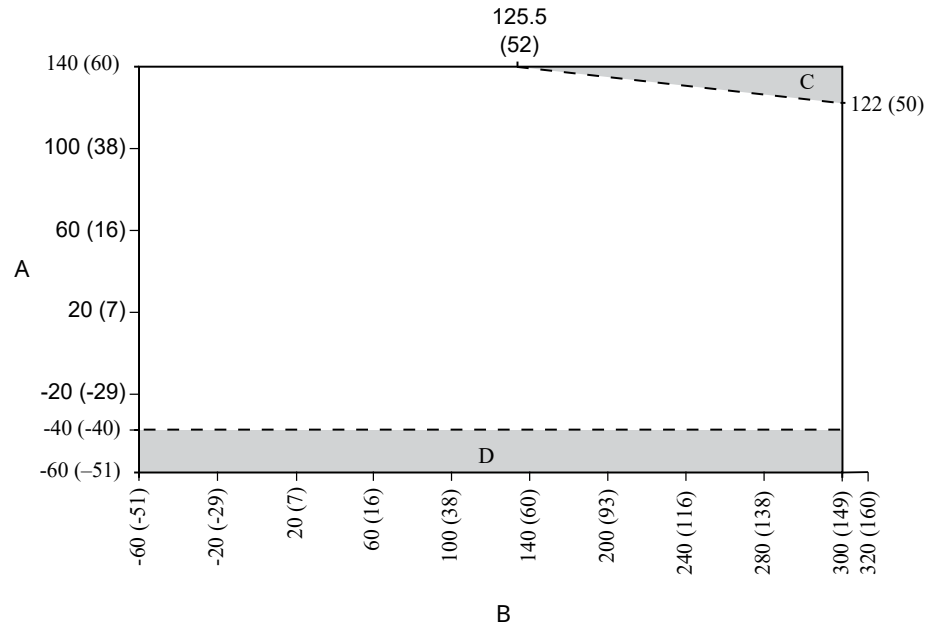

- A. Ambient temperature of core processor or transmitter in °F (°C)
- B. Maximum process temperature in °F (°C)
- C. Mount transmitter remotely and use a junction box
- D. Temperature is below -40 °F (-40 °C); mount transmitter remotely and use a junction box

2.4 Recommendations for hygienic and self-draining applications

For optimal cleanability and drainability:

- If possible, install the sensor in a vertical pipeline with the process fluid flowing upward through the sensor.
- The minimum angle of inclination of the sensor depends on the process fitting. See [Figure 2-1](#) and [Table 2-3](#).
- For clean-in-place (CIP) applications, Micro Motion recommends using the generally-accepted flow velocity of at least 1.5 m/s for cleaning the sensor.
- If the process piping must be larger than the sensor, eccentric reducers may be used to ensure full drainability. In this case, the process end connections for the piping and sensor must be the same size. See [Figure 2-2](#).

Note

As part of the cleaning process, you can purge skid-based systems with nitrogen at the end of the cleaning cycle. When using eccentric reducers, it is possible to trap gas in the section of process piping adjacent to the reducer. Sensor performance can be impacted by intermittent flow of the captured gas in a liquid fluid stream.

- The gap between the electronics housing and sensor body should be inspected periodically. Manually clean this gap when necessary.

- ASME BPE, Tri-Clamp compatible, ISO 2853, DIN 11851, and DIN 11864-1A style process connections require special gaskets to comply with EHEDG requirements for hygienic design.

Figure 2-1: Sensor inclination

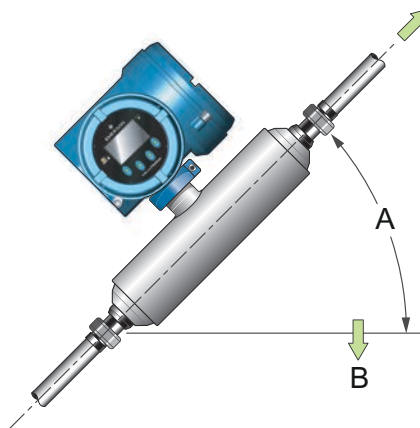

- A. Angle of inclination
- B. Direction of gravity

Table 2-3: Minimum angle of inclination

Model	Fitting code	Description	Min. angle	EHEDG Compliant
T025F, T025T	621	0.5 in (13 mm) Tri-Clamp compatible sanitary clamp	47°	Yes
	670	DN10 DIN 11851 sanitary coupling	47°	Yes
	671	DN15 DIN 11851 sanitary coupling	47°	Yes
	676	DN15 DIN 11864-1A sanitary coupling	47°	Yes
T050F, T050T	621	0.5 in (13 mm) Tri-Clamp compatible sanitary clamp	0°	No
	671	DN15 DIN 11851 sanitary coupling	47°	Yes
	676	DN15 DIN 11864-1A sanitary coupling	47°	Yes
T075F, T075T	622	0.75 in (19.0 mm) Tri-Clamp compatible sanitary clamp	0°	No
	623	1 in (25 mm) Tri-Clamp compatible sanitary clamp	47°	Yes
	662	DN25 ISO 2853 (IDF) sanitary coupling	47°	Yes
	672	DN25 DIN 11851 sanitary coupling	47°	Yes
	677	DN25 DIN 11864-1A sanitary coupling	47°	Yes
	692	DN25 SMS 1145 sanitary coupling	32°	No
T100F, T100T	623	1 in (25 mm) Tri-Clamp compatible sanitary clamp	0°	No
	624	1.5 in (38 mm) Tri-Clamp compatible sanitary clamp	47°	Yes
	672	DN25 DIN 11851 sanitary coupling	0°	Yes

Table 2-3: Minimum angle of inclination (continued)

Model	Fitting code	Description	Min. angle	EHEDG Compliant
	677	DN25 DIN 11864-1A sanitary coupling	0°	Yes
T150F, T150T	624	1.5 in (38 mm) Tri-Clamp compatible sanitary clamp	0°	No
	625	2 in (51 mm) Tri-Clamp compatible sanitary clamp	47°	Yes
	663	DN51 ISO 2853 (IDF) sanitary coupling	47°	Yes
	673	DN40 DIN 11851 sanitary coupling	0°	Yes
	674	DN50 DIN 11851 sanitary coupling	47°	Yes
	678	DN50 DIN 11864-1A sanitary coupling	47°	No
	693	DN51 SMS 1145 sanitary coupling	32°	No

Figure 2-2: Eccentric reducer

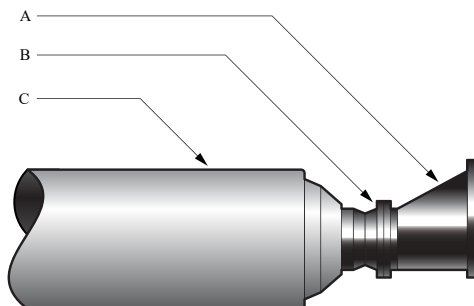

- A. Eccentric reducer
- B. Process end connection is the same size as the sensor connection
- C. Sensor case

3 Mounting

3.1 Mount the sensor

Use common practices to minimize torque and bending load on process connections.

NOTICE

- Lifting the sensor by the electronics or purge connections can damage the device.
- To reduce the risk of collecting liquid in the electronics housing, do not orient transmitters or sensor junction boxes with their conduit openings pointing upward.

Procedure

Mount the sensor.

Notes

- Do not use the sensor to support the piping.
- The sensor does not require external supports. The flanges will support the sensor in any orientation.

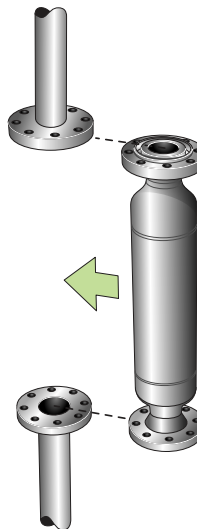

3.2 Attach extended electronics

If your installation has a sensor with extended electronics, you will need to install the extender onto the sensor case.

Extended core processors are matched at the factory to specific sensors. Keep each core processor together with the sensor with which it was shipped.

NOTICE

Keep the extender and feedthrough clean and dry. Moisture or debris in the extender or feedthrough can damage electronics and result in measurement error or flow meter failure.

Procedure

1. Remove and recycle the plastic cap from the feedthrough on the sensor.

Figure 3-1: Feedthrough and extender components

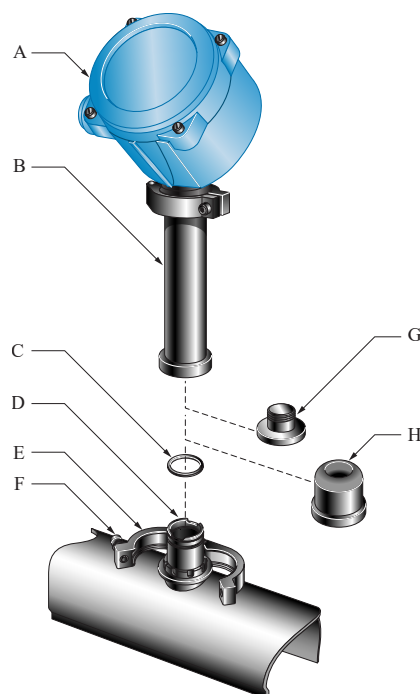

- A. Transmitter or core processor
- B. Extender
- C. O-ring
- D. Feedthrough
- E. Clamping ring
- F. Clamping screw
- G. Plastic plug
- H. Plastic cap

2. Loosen the clamping screw and remove the clamping ring. Leave the O-ring in place on the feedthrough.
3. Remove and recycle the plastic plug from the extender.
4. Fit the extender onto the feedthrough by carefully aligning the notches on the bottom of the extender with the notches on the feedthrough.
5. Close the clamping ring and tighten the clamping screw to 13 in lbf (1.47 N m) to 18 in lbf (2.03 N m).

3.3 Rotate junction box or 800 core processor (optional)

An integrally mounted junction box or 800 core processor can be rotated to one of eight possible positions in 45 degree increments.

Figure 3-2: Parts for rotating the junction box or 800 core processor on the sensor

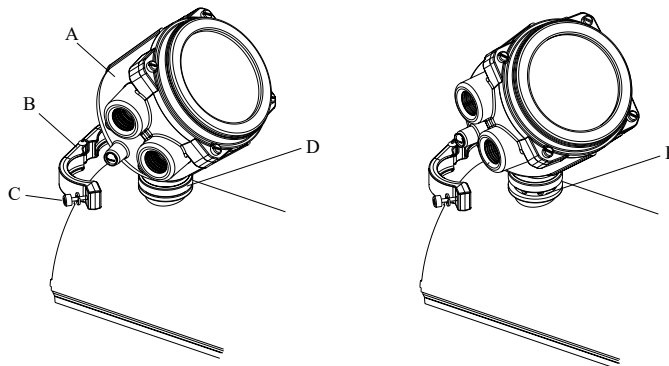

- A. Housing
- B. Clamping ring
- C. Clamping ring screw
- D. Feedthrough
- E. Alignment notches

Note

The 800 core processor is shown in [Figure 3-2](#). The junction box has a somewhat different appearance.

Procedure

1. Loosen the clamping ring screw and remove the clamping ring.
2. Gently separate the housing from the feedthrough, but only until there is sufficient clearance from the alignment notches to rotate the housing.
3. Rotate the housing to the desired position and in line with the alignment notches.
4. Seat the housing onto the feedthrough.
5. Replace the clamping ring and tighten the clamping ring screw.

4 Transmitter power and I/O wiring

4.1 Options for wiring

The wiring procedure you follow depends on which electronics option you have.

Table 4-1: Wiring procedures by electronics option

Electronics option	Wiring procedure
Integral transmitter	The transmitter is already connected to the sensor. No wiring is required between sensor and transmitter. See the transmitter installation manual for wiring the power and signal cable to the transmitter.
MVD™ Direct Connect™	There is no transmitter to wire. See the Micro Motion MVD Direct Connect Meters Installation Manual for wiring the power and signal cable between the sensor and the direct host.
Integral core processor with remote transmitter	The core processor is already connected to the sensor. Connect a 4-wire cable between the core processor and transmitter. Refer to Connect 4-wire cable .
Remote core processor attached to transmitter	Connect a 9-wire cable between the sensor and the transmitter/core processor. Refer to both Connect the 9-wire cable and the Micro Motion 9-Wire Flowmeter Cable Preparation and Installation Manual .
Remote core processor separate from transmitter – <i>double-hop</i>	<ul style="list-style-type: none"> Connect a 4-wire cable between the core processor and transmitter. Refer to Connect 4-wire cable. Connect a 9-wire cable between the sensor and the core processor. Refer to both Connect the 9-wire cable and the Micro Motion 9-Wire Flowmeter Cable Preparation and Installation Manual.



WARNING

Make sure the hazardous area specified on the sensor approval tag is suitable for the environment in which the sensor will be installed. Failure to comply with the requirements for intrinsic safety in a hazardous area could result in an explosion resulting in injury or death.

NOTICE

Fully close and tighten all housing covers and conduit openings. Improperly sealed housings can expose electronics to moisture, which can cause measurement error or flow meter failure. Inspect and grease all gaskets and O-rings.

4.2 Connect 4-wire cable

4.2.1 4-wire cable types and usage

Micro Motion offers two types of 4-wire cable: shielded and armored. Both types contain shield drain wires.

The cable supplied by Micro Motion consists of one pair of red and black 18 AWG (0.823 mm²) wires for the VDC connection, and one pair of white and green 22 AWG (0.326 mm²) wires for the RS-485 connection.

User-supplied cable must meet the following requirements:

- Twisted pair construction.
- Applicable hazardous area requirements, if the core processor is installed in a hazardous area.
- Wire gauge appropriate for the cable length between the core processor and the transmitter, or the host.

Wire gauge	Maximum cable length
VDC 22 AWG (0.326 mm ²)	300 ft (91 m)
VDC 20 AWG (0.518 mm ²)	500 ft (152 m)
VDC 18 AWG (0.823 mm ²)	1,000 ft (305 m)
RS-485 22 AWG (0.326 mm ²) or larger	1,000 ft (305 m)

4.2.2 Prepare a cable with a metal conduit

Procedure

1. Remove the core processor cover using a flat-blade screw driver.
2. Run the conduit to the sensor.
3. Pull the cable through the conduit.
4. Cut the drain wires and let them float at both ends of the conduit.

4.2.3 Prepare a cable with user-supplied cable glands

Procedure

1. Remove the core processor cover using a flat-blade screw driver.
2. Pass the wires through the gland nut and gland body.

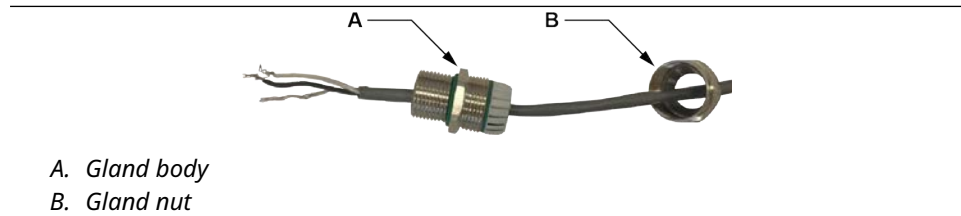

3. Terminate the RS-485 shield and drain wires to the housing internal grounding screw.
4. Assemble the gland according to vendor instructions.

4.2.4 Prepare a cable with Micro Motion-supplied cable glands

Procedure

1. Remove the core processor cover using a flat-blade screw driver.
2. Pass the wires through the gland nut and clamping insert.

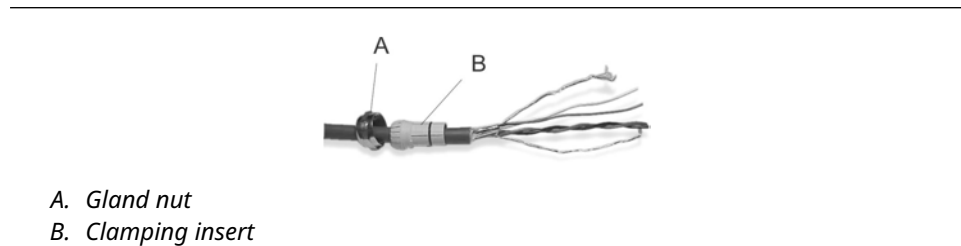

3. Strip the cable jacket.

Option	Description
NPT gland type	Strip 4.5 in (114 mm)
M20 gland type	Strip 4.25 in (108 mm)

4. Remove the clear wrap and filler material.
5. Strip most of the shielding.

Option	Description
NPT gland type	Strip all but 0.75 in (19 mm)
M20 gland type	Strip all but 0.5 in (13 mm)

6. Wrap the drain wires twice around the shield and cut off the excess drain wires.



A. Drain wires wrapped around shield

7. For foil (shielded cable) only:

Note

For braided (armored cable) skip this step and continue to the next step.

Option	Description
NPT gland type	<p>a. Slide the shielded heat shrink over the drain wires. Ensure that the wires are completely covered.</p> <p>b. Apply 250 °F (121.1 °C) heat to shrink the tubing. Do not burn the cable.</p> <p>c. Position the clamping insert so the interior end is flush with the braid of the heat shrink.</p>
	<p>A. Shielded heat shrink B. After heat is applied</p>
M20 gland type	<p>Trim 0.3 in (8 mm).</p>
	<p>A. Trim</p>

8. Assemble the gland by folding the shield or braid back over the clamping insert and 0.125 in (3 mm) past the O-ring.

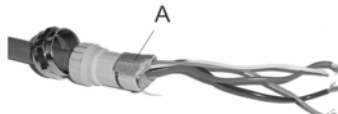

A. Shield folded back

9. Install the gland body into the conduit opening on the core processor housing.

10. Insert the wires through the gland body and tighten the gland nut onto the gland body.



- A. Shield folded back
B. Gland body
-

4.2.5 Connect the wires to the core processor terminals

After the 4-wire cable has been prepared and shielded (if required), connect the individual wires of the 4-wire cable to the terminals on the core processor.

Procedure

1. Connect the wires to the core processor terminals.
 - If you are connecting to a standard core processor, use the following image and connections:

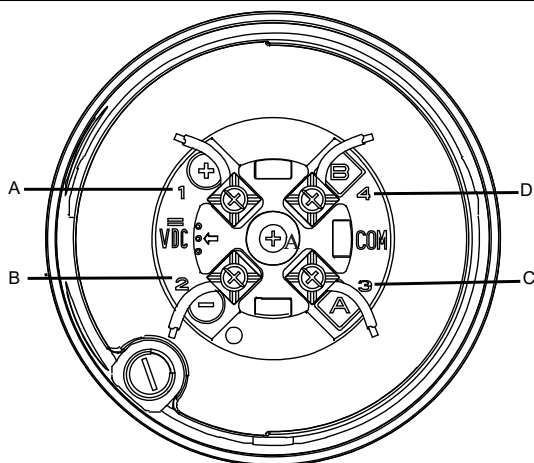

- A. Terminal 1 (Power supply +): Red wire
B. Terminal 2 (Power supply -): Black wire
C. Terminal 3 (RS-485/A): White wire
D. Terminal 4 (RS-485/B): Green wire
-

- If you are connecting to an enhanced core processor, use the [Enhanced core processor](#) and connections:

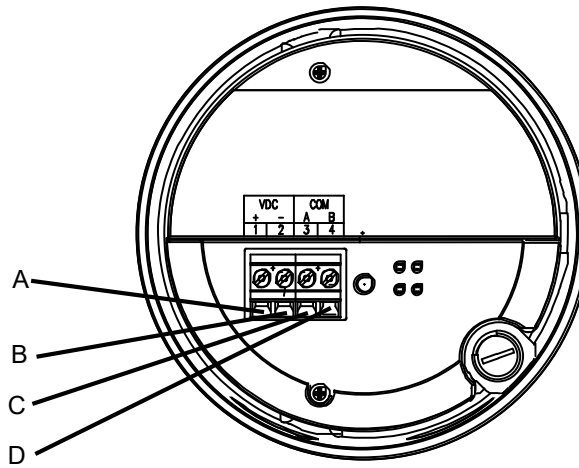

- A. Terminal 1 (Power supply +): Red wire
- B. Terminal 2 (Power supply -): Black wire
- C. Terminal 3 (RS-485/A): White wire
- D. Terminal 4 (RS-485/B): Green wire

2. Reinstall the core processor cover.
3. Torque the cover screws to:
 - For aluminum housing: 10 in lbf (1.13 N m) to 13 in lbf (1.47 N m)
 - For stainless steel housing: minimum 19 in lbf (2.15 N m)If properly seated, there will be no gap between cover and base.
4. Connect the wires to the transmitter terminals using the transmitter installation manual.

4.3 Connect the 9-wire cable

Procedure

1. Prepare and install the cable according to the instructions in the [Micro Motion 9-Wire Flowmeter Cable Preparation and Installation Manual](#).
2. Insert the stripped ends of the individual wires into the terminal blocks of the junction box.
Ensure that no bare wires remain exposed.
3. Match the wires color for color.
For wiring at the transmitter or remote core processor, refer to the transmitter documentation.
4. Tighten the screws to hold the wires in place.
5. Ensure integrity of gaskets; then tightly close and seal the junction box cover and all housing covers.
6. Refer to the transmitter installation manual for signal and power wiring instructions.

5 Grounding

The meter must be grounded according to the standards that are applicable at the site. The customer is responsible for knowing and complying with all applicable standards.

Prerequisites

Use the following guides for grounding practices:

- In Europe, IEC 60079-14 is applicable to most installations, in particular sections 16.2.2.3 and 16.2.2.4.
- In the USA and Canada, ISA 12.06.01 Part 1 provides examples with associated applications and requirements.

If no external standards are applicable, follow these guidelines to ground the sensor:

- Use copper wire, 14 AWG (2.08 mm²) or larger wire size.
- Keep all ground leads as short as possible, less than 1 Ω impedance.
- Connect ground leads directly to earth or follow plant standards.

NOTICE

Ground the flow meter to earth or follow ground network requirements for the facility. Improper grounding can cause measurement error.

Procedure

- Check the joints in the pipeline.
 - If the joints in the pipeline are ground-bonded, the sensor is automatically grounded and no further action is necessary (unless required by local code).
 - If the joints in the pipeline are not grounded, connect a ground wire to the grounding screw located on the sensor electronics.

Tip

The sensor electronics may be a transmitter, core processor, or junction box. The grounding screw may be internal or external.

6 Supplementary information

6.1 Purge the sensor case

Prerequisites

Make sure the following are available before beginning the purge procedure:

- PTFE™ tape
- Argon or nitrogen gas sufficient to purge the sensor case

If the sensor has purge fittings, they should remain sealed at all times. The sensor is purged of all oxygen and sealed at the factory. If the purge plugs are never removed, it is not necessary to purge or re-seal the sensor. For more information, contact customer support.

Whenever a purge plug is removed from the sensor case, you must purge the case again.

Procedure

1. Shut down the process, or set control devices for manual operation.

NOTICE

Before performing the case purging procedure, shut down the process or set the control devices for manual operation. Performing the purge procedure while the flow meter is operating could affect measurement accuracy, resulting in inaccurate flow signals.

2. Remove both purge plugs from the sensor case. If purge lines are being used, open the valve in the purge lines.

WARNING

- If a rupture disk has been installed on the purge fitting, stay clear of the rupture disk pressure relief area. High-pressure fluid escaping from the sensor can cause severe injury or death. Orient the sensor so that personnel and equipment will not be exposed to any discharge along the pressure relief path.
- Take all necessary precautions when removing purge plugs. Removing a purge plug compromises the secondary containment of the sensor and could expose the user to process fluid.
- Improper pressurization of the sensor case could result in injury.

NOTICE

If a rupture disk has been installed on the purge fitting, use thread protectors when removing the purge fitting so as not to damage the disk membrane surrounding the rupture disk.

3. Prepare the purge plugs for reinstallation by wrapping them with 2–3 turns of PTFE tape.
4. Connect the supply of nitrogen or argon gas to the inlet purge connection or open inlet purge line. Leave the outlet connection open.

NOTICE

- Exercise caution to avoid introducing dirt, moisture, rust, or other contaminants into the sensor case.

- If the purge gas is heavier than air (such as argon), locate the inlet lower than the outlet, so that the purge gas will displace air from bottom to top.
- If the purge gas is lighter than air (such as nitrogen), locate the inlet higher than the outlet, so that the purge gas will displace air from top to bottom.

5. Ensure that there is a tight seal between the inlet connection and sensor case, so that air cannot be drawn by suction into the case or purge line during the purging process.
6. Run purge gas through the sensor.

The purge time is the amount of time required for full exchange of atmosphere to inert gas. The larger the line size, the greater amount of time is required to purge the case. If purge lines are being used, increase the purge time to fill the additional volume of the purge line.

Important

Keep the purge gas pressure below 7.25 psi (0.5 bar).

Table 6-1: Purge time

Sensor model	Purge rate	Time, in minutes
T025	20 ft ³ /h (566.3 l/h)	1
T050	20 ft ³ /h (566.3 l/h)	1
T075	20 ft ³ /h (566.3 l/h)	3
T100	20 ft ³ /h (566.3 l/h)	5
T150	20 ft ³ /h (566.3 l/h)	10

7. At the appropriate time, shut off the gas supply; then immediately seal the purge outlet and inlet connections with the purge plugs.
Avoid pressurizing the sensor case. If pressure inside the case elevates above atmospheric pressure during operation, the flow meter density calibration will be inaccurate.
8. Make sure that the purge fitting seals are tight so that air cannot be drawn by suction into the sensor case.



20002172
Rev. BD
2024

For more information: [Emerson.com/global](https://emerson.com/global)

©2024 Micro Motion, Inc. All rights reserved.

The Emerson logo is a trademark and service mark of Emerson Electric Co. Micro Motion, ELITE, ProLink, MVD and MVD Direct Connect marks are marks of one of the Emerson Automation Solutions family of companies. All other marks are property of their respective owners.

MICRO MOTION™

