

Micro Motion™ 1600 Transmitters with Configurable Inputs and Outputs



Safety messages

Safety messages are provided throughout this manual to protect personnel and equipment. Read each safety message carefully before proceeding to the next step.

Safety and approval information

This Micro Motion product complies with all applicable European directives when properly installed in accordance with the instructions in this manual. Refer to the EU Declaration of Conformity for directives that apply to this product. The following are available: the EU Declaration of Conformity, with all applicable European directives, and the complete ATEX installation drawings and instructions. In addition, the IECEx installation instructions for installations outside of the European Union and the CSA installation instructions for installations in North America are available at Emerson.com or through your local Micro Motion support center.

Information affixed to equipment that complies with the Pressure Equipment Directive, can be found at Emerson.com. For hazardous installations in Europe, refer to standard EN 60079-14 if national standards do not apply.

Other information

Troubleshooting information can be found in the appropriate Configuration and Use Manual. Product Data Sheets and Manuals are available from the Micro Motion website at Emerson.com.

Return policy

Follow Emerson procedures when returning equipment. These procedures ensure legal compliance with government transportation agencies and help provide a safe working environment for Emerson employees. If you fail to follow Emerson procedures, then Emerson will not accept your returned equipment.

Return procedures and forms are available on our web support site at Emerson.com, or by calling the Micro Motion Customer Service department.

Contents

Chapter 1	Before you begin.....	5
	1.1 About this document.....	5
	1.2 Hazard messages.....	5
	1.3 Related documentation.....	5
Chapter 2	Planning.....	7
	2.1 Installation checklist.....	7
	2.2 Additional considerations for retrofitting existing installations.....	8
	2.3 Power requirements.....	9
Chapter 3	Mounting and sensor wiring.....	11
	3.1 Mounting and sensor wiring for integral-mount transmitters.....	11
	3.2 Mounting transmitters.....	11
	3.3 Wire a remote-mount transmitter to the sensor.....	12
	3.4 Ground the meter components.....	14
	3.5 Rotate the transmitter on the sensor (optional).....	15
	3.6 Rotate the transmitter display.....	16
	3.7 Rotate the 1600 transmitter housing on a remote-mount transmitter (optional).....	16
Chapter 4	Wiring the channels.....	19
	4.1 Available channels.....	19
	4.2 Wire the mA/HART [®] output.....	19
	4.3 Wire the Frequency Output.....	20
	4.4 Wire the Discrete Output.....	21
	4.5 Wire the RS-485 output	21
	4.6 Wire the I/O channel using an M12-terminated cable (optional).....	22
Chapter 5	Power supply wiring.....	23
	5.1 Wiring the power supply.....	23
	5.2 Wire the power supply using an M12-terminated cable (optional).....	23
Chapter 6	Power up the transmitter.....	25
Chapter 7	Guided setup.....	27
Chapter 8	Components of the transmitter display.....	29
	8.1 Access and use the display menus.....	30
Chapter 9	Available service port connection.....	35
Chapter 10	Communicating with the transmitter.....	37

1 Before you begin

1.1 About this document

This manual provides information on planning, mounting, wiring, and initial setup of the Micro Motion transmitter. For information on full configuration, maintenance, troubleshooting, or service of the transmitter, see the appropriate configuration and use manual.

The information in this document assumes that users understand basic transmitter and sensor installation, configuration, and maintenance concepts and procedures.

1.2 Hazard messages

This document uses the following criteria for hazard messages based on ANSI standards Z535.6-2011 (R2017).



DANGER

Serious injury or death will occur if a hazardous situation is not avoided.



WARNING

Serious injury or death could occur if a hazardous situation is not avoided.



CAUTION

Minor or moderate injury will or could occur if a hazardous situation is not avoided.

NOTICE

Data loss, property damage, hardware damage, or software damage can occur if a situation is not avoided. There is no credible risk of physical injury.

Physical access



WARNING

Unauthorized personnel can potentially cause significant damage and/or misconfiguration of end users' equipment. Protect against all intentional or unintentional unauthorized use.

Physical security is an important part of any security program and fundamental to protecting your system. Restrict physical access to protect users' assets. This is true for all systems used within the facility.

1.3 Related documentation

You can find all product documentation on the product documentation DVD shipped with the product or at [Emerson.com](https://www.emerson.com).

See any of the following documents for more information:

- *Micro Motion 1600 Product Data Sheet*
- *Micro Motion 1600 Transmitters with Configurable Inputs and Outputs: Configuration and Use Manual*

- Sensor installation manual

2 Planning

2.1 Installation checklist

- If possible, install the transmitter in a location that will prevent direct exposure to sunlight. The environmental limits for the transmitter may be further restricted by hazardous area approvals.

- If you plan to mount the transmitter in a hazardous area:

⚠ WARNING

- Verify that the transmitter has the appropriate hazardous area approval. Each transmitter has a hazardous area approval tag attached to the transmitter housing.
- Ensure that any cable used between the transmitter and the sensor meets the hazardous area requirements.
- For ATEX/IECEX installations, strictly adhere to the safety instructions documented in the ATEX/IECEX approvals documentation available on the product documentation DVD shipped with the product or at [Emerson.com](https://www.emerson.com).

- Verify that you have the appropriate cable and required cable installation parts for your installation. For wiring between the transmitter and sensor, verify the maximum cable length does not exceed 1,000 ft (305 m). For installations with Smart Meter Verification, the maximum is 60 ft (18.28 m).

- You can mount the transmitter in any orientation as long as the conduit openings do not point upward.

Installing the transmitter with the conduit openings facing upward risks condensation moisture entering the transmitter housing, which could damage the transmitter.

Following are examples of possible orientations for the transmitter:

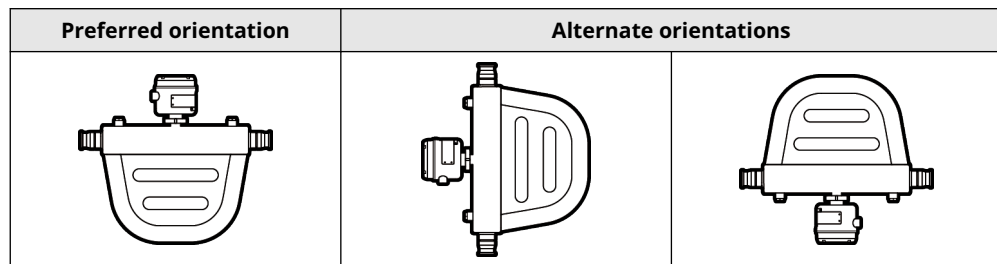

- To maintain the ingress protection in a Hazardous Area or Safe Area; a thread sealant, a sealing washer, or O-ring must be applied to any fittings, adapters, or blanking elements used on conduit entries/threaded joints. Selection and installation must be carried out by qualified personnel and in accordance with EN/IEC 60079-14 for ATEX/IECEX, NEC/CEC for North America, or for other world areas please follow their applicable installation instructions.
Ensure any selected thread sealant is acceptable with your local jurisdictional authority. Review this information before performing the tasks in [Wiring the channels](#).

- Mount the meter in a location and orientation that satisfies the following conditions:

- Allows sufficient clearance to open the transmitter housing cover. Install with 8 in (203 mm) to 10 in (254 mm) clearance at the wiring access points.
- Provides clear access for installing cabling to the transmitter.
- Provides clear access to all wiring terminals for troubleshooting.

2.2 Additional considerations for retrofitting existing installations

- The transmitter installation may require 3 in (76 mm) to 6 in (152 mm) of additional wiring for the input/output and power connections. This length would be in addition to the currently installed wiring. Confirm you have the additional wiring necessary for the new installation.
- Before removing the existing transmitter, be sure to record the configuration data for the currently installed transmitter. At initial startup of the newly installed transmitter, you will be prompted to configure the meter via a guided setup.

Record the following information (if applicable):

Variable	Setting
Tag	
Mass flow units	
Volume flow units	
Density units	
Temperature units	
Channel configuration	
mA Output (if licensed)	<ul style="list-style-type: none"> — Power (Internal): — Source: — Scaling (LRV, URV): — Fault Action:
Frequency Output (if licensed)	<ul style="list-style-type: none"> — Power (External): — Source: — Scaling (Frequency Factor or Flow Rate Factor): — Fault Action: — Fault Frequency:
Discrete Output (if licensed)	<ul style="list-style-type: none"> — Power (External): — Source: — Scaling: — Fault Action:
RS-485 (if licensed)	<ul style="list-style-type: none"> — Modbus Address: — Floating-Point Byte Order: — Fault Action:

Variable	Setting
Calibration parameters (for 9-wire installations only)	
Flow calibration factor	FCF (Flow Cal or Flow Calibration Factor):
Density calibration factors	<ul style="list-style-type: none"> — D1: — D2: — K1: — K2: — TC: — FD:

2.3 Power requirements

Universal (self-switching) AC/DC input, automatically recognizes supply voltage:

- 18 VDC to 100 VDC, 3.5 W typical, 8 W maximum
- 85 to 240 VAC, 50/60 Hz, 3.5 W typical, 8 W maximum
- One pair of wiring terminals accepts either AC or DC power
- One internal ground lug for power-supply ground wiring

Note

For DC power:

- Power requirements assume a single transmitter per cable.
- At start-up for in-rush current, the power source must provide a minimum of 1.5 amps of short-term current (1 ms) per transmitter and not pull voltage below 18 VDC.
- Length and conductor diameter of the power cable must be sized to provide 18 VDC minimum at the power terminals, at a load current of 0.5 amps.

Cable sizing formula

$$M = 18V + (R \times L \times 0.2A)$$

- M: minimum supply voltage
- R: cable resistance
- L: cable length (in Ω /ft)

Typical power cable resistance at 68 °F (20.0 °C)

Wire gauge	Resistance
14 AWG	0.0050 Ω /ft
16 AWG	0.0080 Ω /ft
18 AWG	0.0128 Ω /ft
20 AWG	0.0204 Ω /ft
2.5 mm ²	0.0136 Ω /m
1.5 mm ²	0.0228 Ω /m
1.0 mm ²	0.0340 Ω /m

Wire gauge	Resistance
0.75 mm ²	0.0460 Ω/m
0.50 mm ²	0.0680 Ω/m

3 Mounting and sensor wiring

3.1 Mounting and sensor wiring for integral-mount transmitters

There are no separate mounting requirements for integral transmitters, and there is no need to connect wiring between the transmitter and the sensor.

3.2 Mounting transmitters

There is one option available for mounting 1600 remote transmitters:

- Mount the transmitter to an instrument pole.

3.2.1 Mount the transmitter to a pole

Prerequisites

- Ensure that the instrument pole extends at least 12 in (305 mm) from a rigid base and is no more than 2 in (51 mm) in diameter.
- Confirm that you have the necessary tools, and the instrument-pole mounting kit shipped with the transmitter.

Procedure

For pole-mount installations, fit the U-bolt mounting piece to the instrument pole.

Figure 3-1: Pole-mounting bracket attachment for an aluminum transmitter

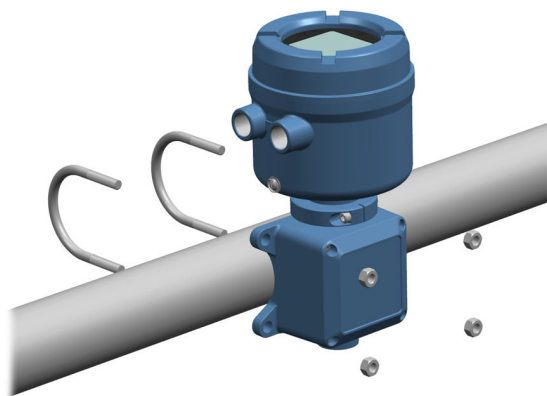

3.3 Wire a remote-mount transmitter to the sensor

Use this procedure to wire a 9-wire remote-mount transmitter to the sensor.

Prerequisites

- Prepare the 9-wire cable as described in the [Micro Motion 9-Wire Flow Meter Cable Preparation and Installation Guide](#).
- Connect the cable to the sensor-mounted core processor or junction box as described in the sensor documentation. You can access all product documentation on the documentation DVD shipped with the product or at [Emerson.com](https://www.emerson.com).

Procedure

1. Remove the transmitter-to-sensor wiring compartment cover to reveal the terminal connections.

Figure 3-2: Removal of the transmitter-to-sensor wiring compartment cover

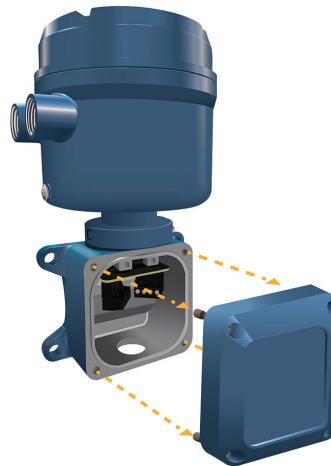

2. Feed the sensor wiring cable into the transmitter wiring compartment.

Figure 3-3: Sensor wiring feedthrough



3. Connect the sensor wires to the appropriate terminals.
 - See [Figure 3-4](#) for 9-wire terminal connections.

Figure 3-4: 9-wire transmitter-to-sensor wiring connections



Note

Connect the four drain wires in the 9-wire cable to the ground screw located inside the junction box.

4. Replace the transmitter-to-sensor wiring compartment cover and tighten the screws to 14 in lbf (1.58 N m) to 16 in lbf (1.81 N m).

3.4 Ground the meter components

Prerequisites

NOTICE

Improper grounding could cause inaccurate measurements or meter failure.

WARNING

Improper grounding could result in an explosion causing death or serious injury.

Note

For hazardous area installations in Europe, refer to standard EN 60079-14 or national standards.

If national standards are not in effect, adhere to the following guidelines for grounding:

- Use copper wire, 14 AWG (2.08 mm²) or larger wire size.
- Keep all ground leads as short as possible, less than 1 Ω impedance.
- Connect ground leads directly to earth, or follow plant standards.

Procedure

1. Ground the Coriolis sensor according to the instructions in the sensor installation manual.
2. Ground the transmitter according to applicable local standards, using the transmitter's internal or external ground screw.
 - The internal ground screw is located inside the power wiring compartment.

Figure 3-5: Internal ground screw

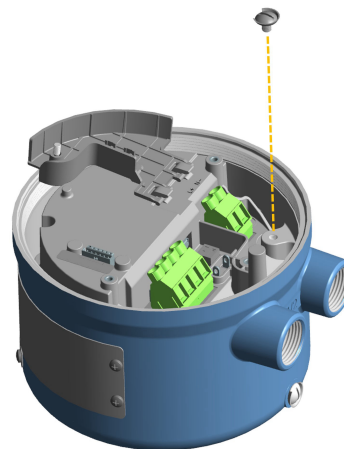

- The earth ground terminal is located inside the power wiring compartment.
- The external ground screw is located on the outside of the transmitter housing below the transmitter tag.

Figure 3-6: External ground screw

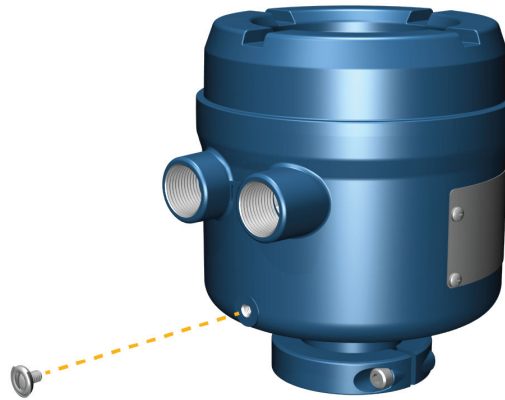

3.5 Rotate the transmitter on the sensor (optional)

In integral installations, you can rotate the transmitter on the sensor up to 360°.

Procedure

1. Using a 4 mm hex key, loosen and remove the clamp securing the transmitter head in place.

Figure 3-7: Removal of the sensor clamp

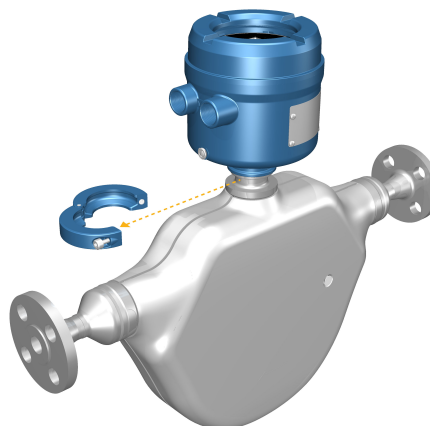

2. Rotate the transmitter to the desired position.
You can rotate the transmitter to any position, but a stop exists that will not allow a full 360° rotation.
3. Replace the aluminum clamp in its original position and tighten the cap screw.
Torque to 29 in lbf (3.28 N m) to 31 in lbf (3.50 N m).
4. Replace the stainless steel clamp in its original position and tighten the cap screw.
Torque to 21 in lbf (2.37 N m) to 23 in lbf (2.60 N m).

3.6 Rotate the transmitter display

Configure the software to rotate the transmitter display 0°, 90°, 180°, or 270°. You cannot physically rotate the display.

Procedure

1. Choose **Menu** → **Configuration** → **Display Settings** → **Rotation**.
2. Select the appropriate direction.

3.7 Rotate the 1600 transmitter housing on a remote-mount transmitter (optional)

In remote-mount installations, you can rotate the 1600 transmitter, but please note that a stop exists that will not allow for full 360 rotation.

Procedure

1. Using a 4 mm hex key, loosen and remove the clamp securing the sensor wiring junction box in place.

Figure 3-8: Remove the clamp

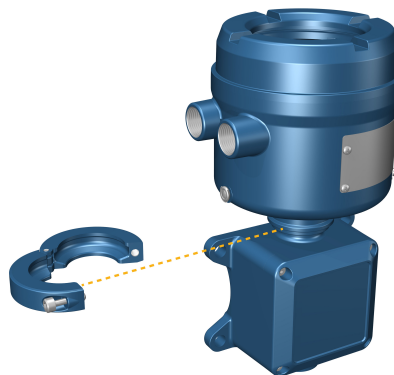

2. Gently rotate the junction box to the desired position.
3. Gently set the junction box into its new position, confirming that the position is locked.
4. Replace the clamp in its original position and tighten the cap screw. Torque to 29 in lbf (3.28 N m) to 31 in lbf (3.50 N m).

Figure 3-9: Rotate transmitter head and replace clamp

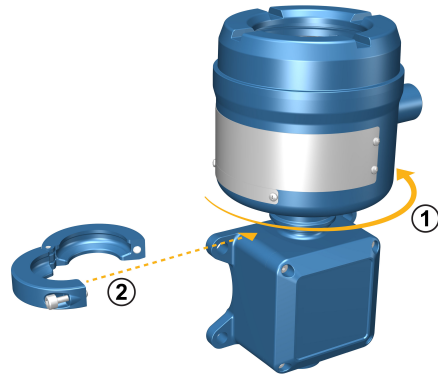

4 Wiring the channels

Note

Before wiring the channels, refer to the ingress wiring guidelines towards the end of [Installation checklist](#).

4.1 Available channels

Signal	Channel A	Channel B
Channel options	mA/ HART	Frequency Output
		Discrete Output

Signal	Channel A	Channel B
Channel options	RS-485	Frequency Output
		Discrete Output

4.2 Wire the mA/HART[®] output

Wire the mA/HART output in explosion-proof, nonincendive, or nonhazardous installations.

Important

Meter installation and wiring should be performed only by suitably-trained personnel.

4.2.1 Wire the mA/HART[®] output (internally powered)

Procedure

Wire to the appropriate output terminal and pins.

Figure 4-1: mA/HART output wiring (internally powered)

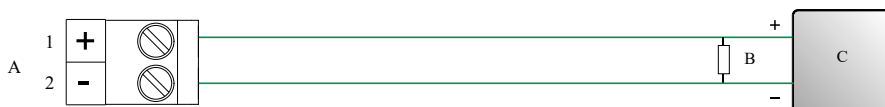

- A. mA/HART output
- B. 250–600 Ω resistance
- C. HART device

4.2.2 Wire the mA/HART[®] multidrop installation (internally powered)

Procedure

See the [Figure 4-2](#) for information on wiring a mA/HART multidrop installation.

Figure 4-2: mA/HART multidrop wiring

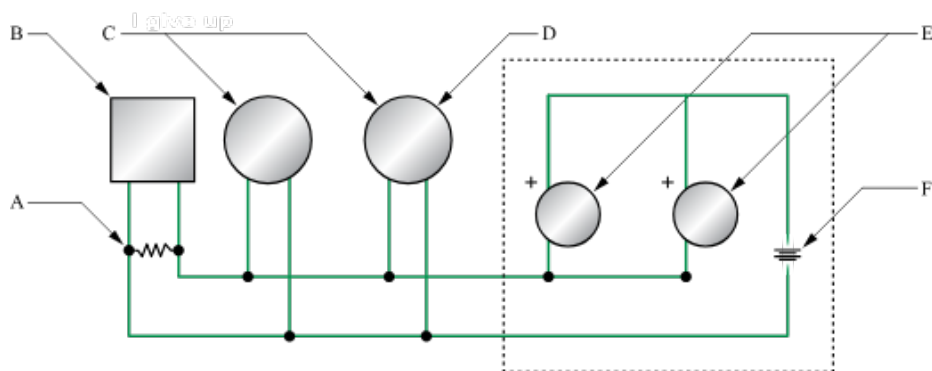

- A. 250–600 Ω resistance
- B. HART-compatible host or controller
- C. HART-compatible transmitter (internally powered)
- D. Micro Motion 1600 transmitter (internally powered) mA/HART connections
- E. SMART FAMILY™ transmitters
- F. 24 VDC loop power supply required for external transmitter

4.3 Wire the Frequency Output

Wire the Frequency Output in nonhazardous installations.

Prerequisites

WARNING

Meter installation and wiring should be performed only by suitably-trained personnel using the appropriate government and corporate safety standards.

Procedure

Wire to the appropriate output terminal and pins.

Figure 4-3: Externally-powered FO wiring

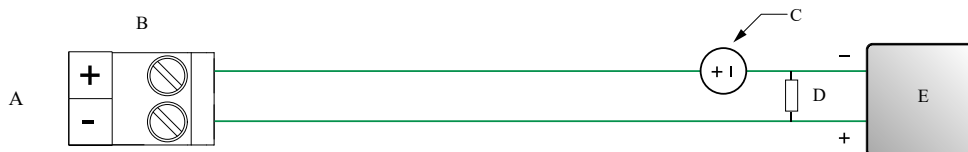

- A. Frequency Output
- B. Channel B
- C. 5–30 VDC (maximum)
- D. 500 mA current (maximum)
- E. Counter

4.4 Wire the Discrete Output

Prerequisites

! WARNING

Meter installation and wiring should be performed only by suitably-trained personnel using the appropriate government and corporate safety standards.

Procedure

Wire to the appropriate output terminal and pins.

Figure 4-4: Externally-powered DO wiring



- A. Discrete Output
- B. Channel B
- C. 3–30 VDC (maximum)
- D. 500 mA current (maximum)
- E. Counter

4.5 Wire the RS-485 output

Use this section to wire the RS-485 output in explosion-proof, nonincendive, or nonhazardous installations.

Procedure

Wire to the appropriate output terminal and pins.

Figure 4-5: RS-485 output wiring

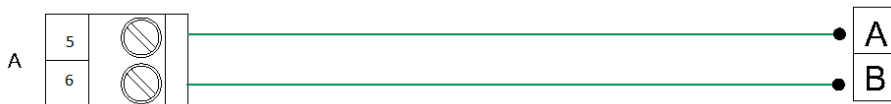

- A. RS-485 output

Note

The transmitter does not provide any RS-485 termination resistance.

4.6 Wire the I/O channel using an M12-terminated cable (optional)

Use this procedure if you are using an M12-terminated cable to wire the I/O channel.

Prerequisites

Obtain an A-coded M12-terminated cable.

Procedure

1. Attach the M12-terminated cable to the configuration I/O connector on the 1600 transmitter.

Figure 4-6: M12-terminated cables to the configuration I/O

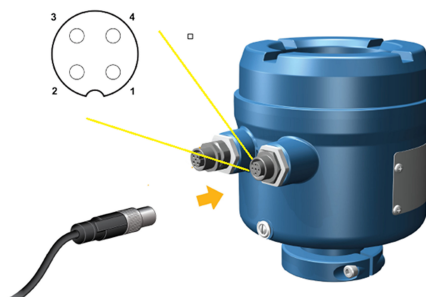

2. Attach the other cable end using the pinouts described in the following table.

Table 4-1: M12 Configuration I/O pinouts

Pin identification	Wire color	Outputs on board	Signal name
Pin 1	Brown	Terminal 3	Channel A + (A +)
Pin 2	White	Terminal 1	Channel B +
Pin 3	Blue	Terminal 4	Channel A - (B -)
Pin 4	Black	Terminal 2	Channel B -

5 Power supply wiring

5.1 Wiring the power supply

You can install a user-supplied switch in the power supply line.

Important

For compliance with the Low Voltage Directive 2014/35/EU (European installations), verify that the transmitter is located in close proximity to a switch.

Figure 5-1: Location of power supply wiring terminals and equipment ground

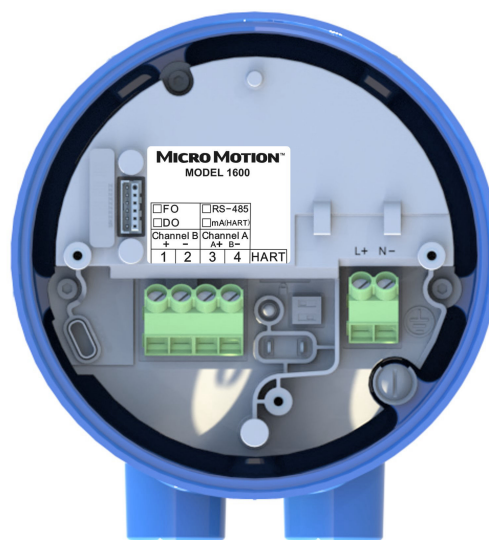

Procedure

1. Remove the housing cover and the display, where applicable.
2. Connect the power supply wires.
 - For DC power, connect to the terminals L + and N -.
 - For AC power, connect to terminals L +, N - and equipment ground.
3. Tighten the two screws of the power connector to hold the wire.

5.2 Wire the power supply using an M12-terminated cable (optional)

Use this procedure if you are using an M12-terminated cable to wire the power supply.

Prerequisites

Obtain an S-coded M12-terminated cable.

Procedure

1. Attach the M12-terminated cable to the power connector on the 1600 transmitter.

Figure 5-2: M12-terminated cables to power supply

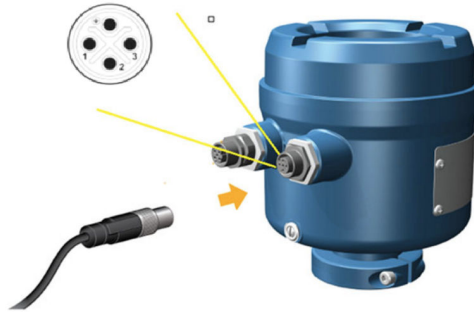

2. Attach the other cable end using the pinouts described in [Table 5-1](#).

Note

For M12 power supply pinouts, only pins 1, 2 and 4 are used.

Table 5-1: M12 power supply pinouts

Pin identification	Wire color	Outputs on board	Signal name
Pin 1	Black	Terminal 1	L +
Pin 2	Black	Terminal 2	N -
Pin 3	Not used	Not used	Not used
Pin 4	Green and yellow	Equipment ground	Ground

6 Power up the transmitter

The transmitter must be powered up for all configuration and commissioning tasks, or for process measurement.

Procedure

1. Ensure that all transmitter and sensor covers and seals are closed.

 **WARNING**

If the transmitter is in a hazardous area, do not remove the housing cover while the transmitter is powered up. Failure to follow these instructions can cause an explosion, resulting in serious injury or death.

2. Turn on the electrical power at the power supply.
The transmitter will automatically perform diagnostic routines. During this period, the Warming Up alert is active. The diagnostic routines should complete in approximately 30 seconds.

Postrequisites

Although the sensor is ready to receive process fluid shortly after power-up, the electronics can take up to 10 minutes to reach thermal equilibrium. Therefore, if this is the initial startup, or if power has been off long enough to allow components to reach ambient temperature, allow the electronics to warm up for approximately 10 minutes before relying on process measurements. During this warm-up period, you may observe minor measurement instability or inaccuracy.

7 Guided setup

At initial startup of the transmitter, the guided configuration screen appears on the transmitter display. This tool guides you through basic configuration of the transmitter. The guided setup allows you to upload configuration files, set the transmitter display options, configure channels, and review sensor calibration data.

8 Components of the transmitter display

The transmitter display includes two status LEDs, a multi-line LCD panel, and four capacitive buttons — left, up, down, and right — used to access the display menus and navigate the display screens.

Figure 8-1: 1600 transmitter display

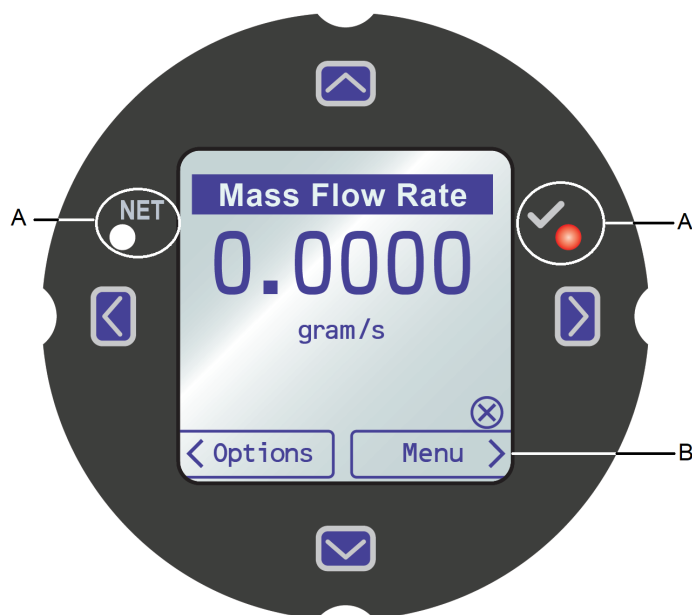

- A. Status LED
- B. LCD Display

Status LEDs

The status LEDs indicate the current state of the transmitter (**STATUS**). From the display, the symbol “√” on the right side is the transmitter status LED. The symbol “NET” on the left side is the network status LED. The 1600 status LED supports NE107 mode. For configuration information, see the *Micro Motion 1600 Transmitters with Configurable Inputs and Outputs: Configuration and Use Manual*.

Table 8-1: Status LED and device status

Status LED condition	Device status
Solid green	No alerts are active.
Solid yellow	One or more alerts are active with Alert Severity = Out of Specification, Maintenance Required, or Function Check.
Solid red	One or more alerts are active with Alert Severity = Failure.
Flashing yellow (1 Hz)	Auto zero or SMV test in progress

LCD panel

In normal operation, the LCD panel shows the current value of the display variables, and their measurement units.

The LCD panel also provides access to the display menus and alert information. From the display menus, you can:

- View the current configuration and make configuration changes.
- Perform procedures such as loop testing and zero verification.
- Run batches.

The alert information allows you to see which alerts are active, acknowledge the alerts individually or as a group, and to see more detailed information for individual alerts.

8.1 Access and use the display menus

The display menus allow you to perform most configuration, administration, and maintenance tasks.

The four switches, $\Leftarrow \Uparrow \Downarrow \Rightarrow$, are used to navigate the menus, make selections, and enter data.

Procedure

1. Observe the action bar at the bottom of the LCD panel.
The action bar displays **Menu** \Rightarrow .
2. Hold your thumb or finger over the \Rightarrow membrane switch to activate it.
The top-level menu is displayed.
3. Navigate the menu using the four membrane switches:
 - Activate \Uparrow or \Downarrow to scroll to the previous or next item in the menu.
 - Activate and hold \Uparrow or \Downarrow (approximately 1 second) to scroll rapidly through numbers or menu options.
 - Activate \Rightarrow to drill down to a lower menu or to select an option.
 - Activate and hold \Rightarrow to save and apply your action.
 - Activate \Leftarrow to return to the previous menu.
 - Activate and hold \Leftarrow to cancel your action.

The action bar is updated with context-sensitive information. The \Rightarrow and \Leftarrow symbols indicate the associated membrane switch.

If the menu or the topic is too large for a single display screen, the ↓ and ↑ symbols at the bottom and top of the LCD panel are used to indicate that you must scroll down or up to see more information.

Figure 8-2: Navigation arrows

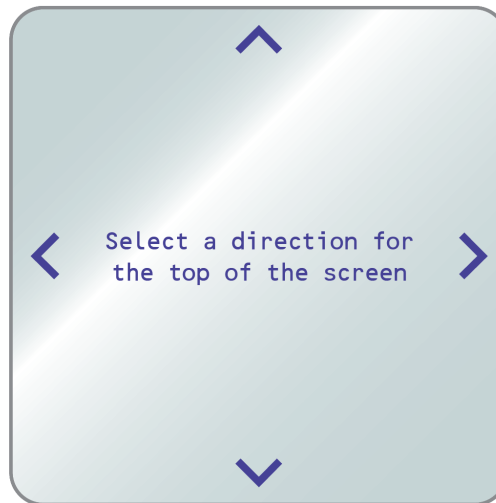

4. If you make a menu choice that leads back to the main menu, or changes to certain procedures such as zero calibration:
 - If display security is not enabled, the display prompts you to activate $\leftarrow \downarrow \rightarrow$, in that order. This feature protects against accidental changes to configuration, but does not provide any security.

Figure 8-3: Security prompts

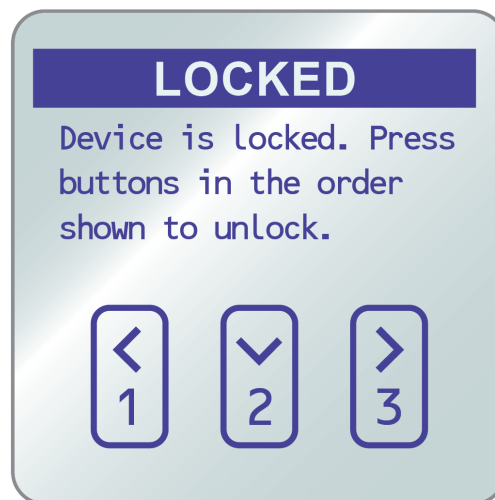

-
- If display security is enabled, the display prompts you to enter the display password.

5. If you make a menu choice that requires entering a numeric value or character string, the display provides a screen similar to the following:

Figure 8-4: Numeric values and character strings

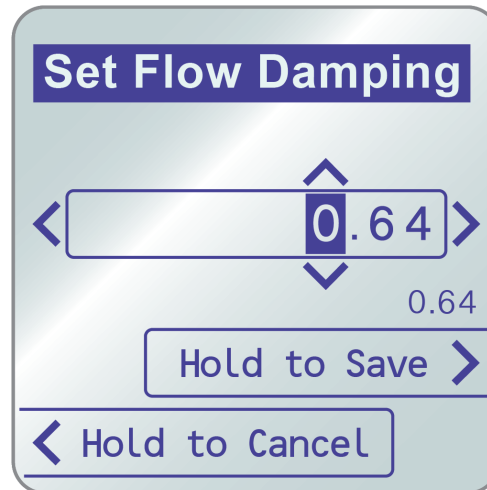

- Activate ⇐ or ⇒ to position the cursor.
 - Activate ↑ and ↓ to scroll through the values that are valid for that position.
 - Repeat until all characters are set.
 - Activate and hold ⇒ to save the value.
6. To exit the display menu system, use either of the following methods:
- Wait until the menu times out and returns to the display variables.
 - Exit each menu separately, working your way back to the top of the menu system.

9 Available service port connection

Use the service port connection to download or upload data from/to the transmitter.

To access the service port, you can use the following signal converter to connect to the service port terminals:

- USB A to USB Type C
- USB Type C to USB Type C

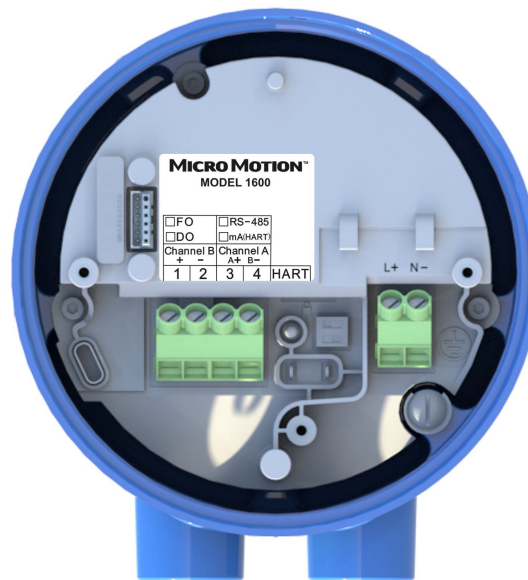

⚠ WARNING

If the transmitter is in a hazardous area, do not remove the housing cover while the transmitter is powered up. Failure to follow these instructions can cause an explosion, resulting in serious injury or death.

10 Communicating with the transmitter

Use either the HART® terminals connected to ProLink™ III or a Trex unit to download or upload data from/to the transmitter, because the service port is for factory use only.

Procedure

1. To connect to the transmitter terminals or to the HART connection posts:
 - a) Remove the transmitter end cap.
 - b) Attach the leads from the Field Communicator to terminals 1 and 2 on the transmitter, or to the HART connection posts, and add resistance as required.
The Field Communicator must be connected across a resistance of 250–600 Ω.

Tip

HART connections are not polarity-sensitive. It does not matter which lead you attach to which terminal.

2. Turn on the Field Communicator and wait until the main menu is displayed.



MS-00825-0500-1600
Rev. AA
2024

For more information: [Emerson.com/global](https://emerson.com/global)

©2024 Micro Motion, Inc. All rights reserved.

The Emerson logo is a trademark and service mark of Emerson Electric Co. Micro Motion, ELITE, ProLink, MVD and MVD Direct Connect marks are marks of one of the Emerson Automation Solutions family of companies. All other marks are property of their respective owners.

MICRO MOTION™

