

Fisher™ FIELDVUE™ DVC7K Digital Valve Controller

HART Field Device Specification



This page is intentionally left blank.

Table of Contents

Section 1: Introduction

1.1	Scope.....	1
1.2	Purpose.....	1
1.3	Who Should Use This Document?	1
1.4	Abbreviations and Definitions	1
1.5	References.....	2

Section 2: Device Identification

Device Identification	3
-----------------------------	---

Section 3: Product Overview

Product Overview	4
------------------------	---

Section 4: Product Interfaces

4.1	Control Valve Interface	5
4.2	Host Interface	5
4.3	Internal Jumper and Switches.....	6
4.4	Local User Interface	6
4.4.1	Local Controls and Displays.....	6

Section 5: Write Protection

5.1	Write Protection Modes.....	7
-----	-----------------------------	---

Section 6: Dynamic Variables

Dynamic Variables	8
-------------------------	---

Section 7: Device Variables

Device Variables.....	9
-----------------------	---

Section 8: Unit Codes

Unit Codes	10
------------------	----

Section 9: Status Information

9.1	Device Status.....	11
9.2	Universal Commands.....	12
9.3	Command 14: Read Primary Variable Transducer Information	13
9.4	Command 15: Read Device Information	14
9.5	Command 17: Write Message.....	15
9.6	Command 48: Read Additional Device Status.....	16
9.6.1	Alert Enable Mask	18
9.7	Common Practice Commands	19
9.7.1	Burst Mode	19
9.7.2	Condensed Status.....	19
9.8	Command 33: Read Device Variables	20
9.9	Command 35: Write Primary Variable Range Values.....	22
9.10	Command 44: Write Primary Variable Units	24
9.11	Command 50: Read Dynamic Variable Assignments.....	24
9.12	Command 51: Write Dynamic Variable Assignments	25
9.13	Command 52: Set Device Variable Zero.....	27
9.14	Command 53: Set Device Variable Units	28
9.15	Command 54: Read Device Variable Information	29
9.16	Command 59: Write Number of Response Preambles.....	31
9.17	Command 72: Squawk.....	32
9.18	Command 89: Set Real-Time Clock.....	32
9.19	Command 90: Read Real-Time Clock	34
9.20	Command 95: Read Device Communication Statistics	35

Section 10: Device-Specific Commands

	Device-Specific Commands	36
--	--------------------------------	----

Section 11: Performance

	Performance	37
--	-------------------	----

Annex A. Capability Checklist

	Capability Checklist	38
--	----------------------------	----

Section 1: Introduction

1.1 Scope

The Fisher™ FIELDVUE™ DVC7K Digital Valve Controller, revision 1 complies with HART® Protocol Revision 7. This document specifies all the device-specific features and documents HART Protocol implementation details (e.g., the Engineering Unit Codes supported). The functionality of this Field Device is described sufficiently to allow its proper application in a process and its complete support in HART capable Host Applications.

1.2 Purpose

This specification is designed to complement other documentation (e.g., the DVC7K Digital Valve Controller Instruction Manual) by providing a complete, unambiguous description of this Field Device from a HART Communication perspective.

1.3 Who Should Use This Document?

The specification is designed to be a technical reference for HART capable Host Application Developers, System Integrators and knowledgeable End Users. It also provides functional specifications (e.g., commands, enumerations and performance requirements) used during Field Device development, maintenance and testing. This document assumes the reader is familiar with HART Protocol requirements and terminology.

1.4 Abbreviations and Definitions

ADC	Analog to Digital Converter
CN	Capacitance Number; capacitance as a multiple of 5000 pF
DD	Device Description
EEPROM	Electrically Erasable Read-Only Memory
FRAM	Ferroelectric RAM, a type of non-volatile memory
NVM	Non-Volatile Memory
RAM	Random Access Memory
RTD	Resistance Temperature Detector
SIS	Safety Instrumented System

1.5 References

- Bulletin 62.1: DVC7K - Fisher FIELDVUE DVC7K Digital Valve Controller (D104765X012)
- Fisher FIELDVUE DVC7K Digital Valve Controller Quick Start Guide (D104766X012)
- Fisher FIELDVUE DVC7K Digital Valve Controller Instruction Manual (D104767X012)

Section 2: Device Identification

Manufacturer Name: Fisher Controls	Physical Device Category: Valve Positioner
Manufacture ID Code: 19 (13 Hex)	Model Name(s): DVC7K [1312]
HART Protocol Revision: 7.7	Device Type Code: 18 (12 Hex)
Number of Device Variables: 10	Device Revision: 1
Physical Layers Supported: FSK	

Figure 1. Fisher FIELDVUE DVC7K Digital Valve Controller



Section 3: Product Overview

The Fisher FIELDVUE DVC7K Digital Valve Controller is a HART communicating instrument that is used to control valve position using a processed 4 to 20 mA signal as the input. The DVC7K converts this 4 to 20 mA signal to a valve travel position of 0 to 100%.

Section 4: Product Interfaces

4.1 Control Valve Interface

The DVC7K digital valve controller is mechanically attached to the valve's actuator by means of a mounting bracket. The control valve's position is conveyed to the travel sensor of the DVC7K digital valve controller by means of the feedback bracket and magnet assembly attached to the actuator's stem.

Pneumatic tubing connected to the DVC7K brings instrument supply air to the DVC7K and takes controlled output air from the DVC7K to the actuator. Pressure sensors in the DVC7K measure these pressure signals and present them as device variables.

Figure 2. DVC7K Magnetic Assembly

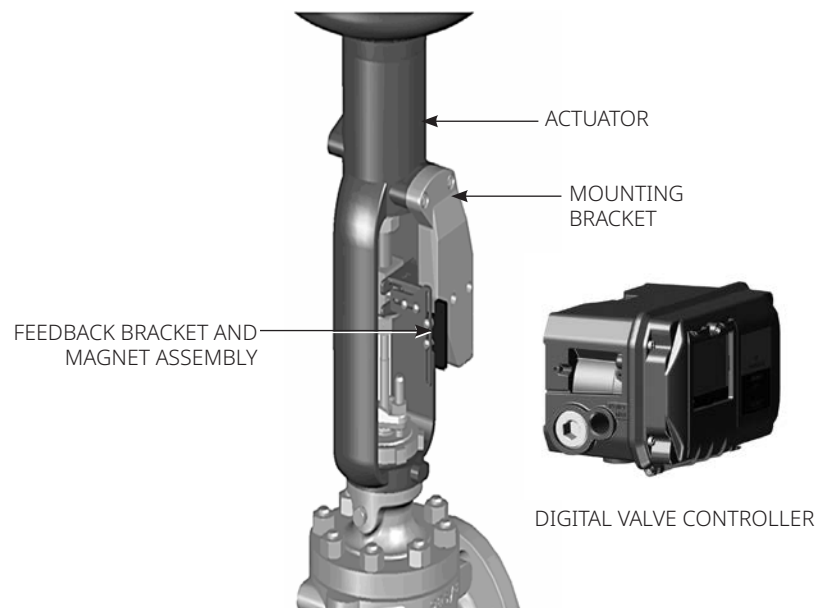

4.2 Host Interface

The input to the DVC7K can either be two-wire 4 to 20 mA current loop (in point-to-point mode) or 24 V DC (in multi-drop mode). This input is connected in the terminal box on marked "LOOP +" and "LOOP -". Refer to the DVC7K Quick Start guide for connection details.

4.3 Internal Jumper and Switches

The input to the DVC7K is determined by the 4 to 20/24 V switch on the front cover assembly. If the DVC7K device was purchased with I/O options, the device has optional output circuits for two solid state dry contact switches. Switch 1 is a normally open circuit and Switch 2 is a normally closed circuit. The output circuits must be enabled with the Local User Interface (LUI) or handheld communicator. Refer to the instruction manual for additional details on the I/O options.

Figure 3. Printed Circuit Board (PCB) Connections and Settings

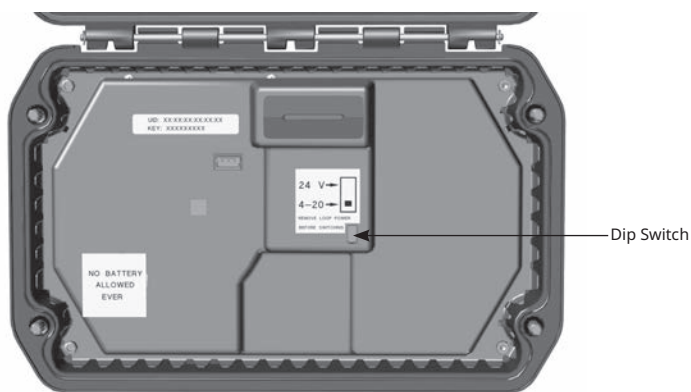

Figure 4. Terminal Box



4.4 Local User Interface

4.4.1 Local Controls and Displays

This device has an intuitive Local User Interface with six push buttons and LCD to setup and calibrate the device without any external tools. Refer to the Quick Start Guide for operation details.

Section 5: Write Protection

5.1 Write Protection Modes

There are three Write Protection modes for the DVC7K: Off, On with LUI Validation, and On without LUI Validation. The default setting is Off. If Write Protection is On with LUI Validation, the device prevents configuration and calibration changes to the instrument and can only be turned Off from the LUI. If Write Protection is On without LUI Validation, the device prevents configuration and calibration changes to the instrument but can be turned Off from the LUI or from a handheld communicator.

Section 6: Dynamic Variables

Four Dynamic Variables are implemented:

Table 1.

	Default Meaning	Units
PV	Input Current (Analog Input)	mA, %
SV*	Setpoint	%
TV*	Output A	psi, Bar, kPa, kg/cm ²
QV*	Travel	%
*User Selectable		

The SV, TV and QV variables are user selectable via Command 51 to any of the following variables. Variable selections are listed below.

Table 2.

Variable	Units
Input Current (Analog Input)	mA, %
Travel	%
Setpoint	%
Travel De-Characterized	%
Output A	psi, Bar, kPa, kg/cm ²
Output B	psi, Bar, kPa, kg/cm ²
Supply	psi, Bar, kPa, kg/cm ²
Differential Pressure	psi, Bar, kPa, kg/cm ²
Temperature	C, F
Setpoint Pre-Characterized	%

Section 7: Device Variables

This Field Device exposes 10 Device Variables. These variables represent measurements taken by the device and are all in float format. These can be read with Commands 9, 33 and 54.

Table 3.

Variable ID	Meaning	Units
0	Input Current (Analog Input)	mA, %
1	Travel	%
2	Setpoint	%
3	Travel De-Characterized	%
4	Output A	psi, Bar, kPa, kg/cm ²
5	Output B	psi, Bar, kPa, kg/cm ²
6	Supply	psi, Bar, kPa, kg/cm ²
7	Differential Pressure	psi, Bar, kPa, kg/cm ²
8	Temperature	C, F
9	Setpoint Pre-Characterized	%

Section 8: Unit Codes

Table 4.

Variable Unit Codes	Units
0	No Units
6	Pounds per square inch, psi
7	Bar
10	Kilograms per square centimeter, kg/cm ²
12	Kilopascals, kPa
32	Celsius, C
33	Fahrenheit, F
39	Milliamperes, mA
57	Percent, %

Section 9: Status Information

9.1 Device Status

The Field Device Status Byte is defined in the HART protocol. The order and meaning of each of the eight bits within the byte are fixed by the protocol. This byte is one of the status bytes included with each HART response. It is not part of the Command 48 data.

Table 5.

Bit	Definition	Description
7	Field Device Malfunction	Activated when conditions that warrant any of the following alerts to become active are met (Refer to 7.3 Additional Device Status (Command #48)): Hall Sensor Alert Program Memory Failed NVM Error RAM Test Error Alert
6	Configuration Changed	Two such bits exist internally, one for each master. The bit presented here is the copy relevant to the master being addressed. Both copies are set when an operation was performed that changed device's configuration (refer to list of commands to determine the commands that are affected). Cleared by Command #38, separately for each master. The value in both copies is maintained through power cycle or a RESET operation.
5	Cold Start	Two such bits exist internally, one for each master. Both bits are set whenever a RESET sequence is executed or at initial power up. Cleared by the first HART command received.
4	More Status Available	Set when the device's copy of Command #48 data is different from the host's copy.
3	Analog Output Fixed	The Loop Current is being held at a fixed value and is not responding to process variations. Set if the DLC is in Tripped state, Fixed current mode or in Multi-drop mode.
2	Analog Output Saturated	The PV has exceeded the lower or upper range values to the point that the Loop Current saturates at 3.8 mA or 20.5 mA.
1	Non-PV Out Of Limits	The process applied to a sensor other than that of the Primary Variable is beyond the operating limits of the device.
0	PV Out of Limits	The process applied to the sensor for the Primary Variable is beyond the operating limits (refer to COMMAND #14: READ PRIMARY VARIABLE TRANSDUCER INFORMATION) of the device.

9.2 Universal Commands

The DVC7K field device implements all Universal Commands.

Command 0: Read Unique Identifier

Command 1: Read Primary Variable

Command 2: Read Loop Current and Percent of Range

Command 3: Read Dynamic Variables and Loop Current

Command 6: Write Polling Address

Command 7: Read Loop Configuration

Command 8: Read Dynamic Variable Classifications

Command 9: Read Device Variable with Status

Command 11: Read Unique Identifier Associated with Tag

Command 12: Read Message

Command 13: Read Tag, Descriptor, Date

Command 14: Read Primary Variable Transducer Information

Command 15: Read Device Information

Command 16: Read Final Assembly Number

Command 17: Write Message

Command 18: Write Tag, Descriptor, Date

Command 19: Write Final Assembly Number

Command 20: Read Long Tag

Command 21: Read Unique Identifier Associated with Long Tag

Command 22: Write Long Tag

Command 38: Reset Configuration Changed Flag

Command 48: Read Additional Status

9.3 Command 14: Read Primary Variable Transducer Information

Reads the Transducer Serial Number, Limits/Minimum Span Units Code, Upper and Lower Transducer Limits and Minimum Span for the Primary Variable Transducer.

- The Transducer limits and minimum span units code will be the same as the Primary Variable units code.
- The Transducer Serial Number is not applicable and thus will be returned as 0. The other bytes are applicable and their value will be based on what unit codes are configured for the Primary Variable.

Note that the real limit is defined in Loop Current but 4 to 20 mA is used here to be consistent with previous Fisher HART devices. It is possible that a host may look at this and try to set the PV Range based off these limits for which the range command only allows 4 to 20.

Request Data Bytes: **None**

Table 6. Response Codes Allowed

Number	Type	Meaning
0	---	Success

Table 7. Response Data Bytes

Byte	Value	Format	Description
0 to 2	0x000000	Uint24	Transducer Serial Number
3	39 (mA)*	Enum8	Transducer Limits and Minimum Span Units Code
4 to 7	20 mA or 100%	Float	Upper Transducer Limit (Same units as Primary Variable)
8 to 11	4 mA or 0%	Float	Lower Transducer Limit (Same units as Primary Variable)
12 to 15	1 mA or 6.25%	Float	Minimum Span (Same units as Primary Variable)

***Note:**

If compatibility mode is enabled, the value returns units from Cmd 44.

9.4 Command 15: Read Device Information

Reads the alarm selection code, transfer function code, range values units code, Primary Variable upper range value, Primary Variable lower range value, damping value and write protect code.

The DVC7K assumes 0% = 4 mA and 100% = 20 mA.

Request Data Bytes: **None**

Table 8. Response Codes Allowed

Number	Type	Meaning
0	---	Success

Table 9. Response Data Bytes

Byte	Value	Format	Description
0	250	Enum8	Primary Variable (PV) Alarm Selection Code (250 - Not Used)
1	0	Enum8	PV Transfer Function Code (0 - Not Supported)
2	39 (mA)*	Enum8	PV Upper and Lower Range Values Units Code
3 to 6	---	Float	PV Upper Range Value
7 to 10	---	Float	PV Lower Range Value
11 to 14	0	Float	PV Damping Value (0 - Units of Seconds) - Not Used
15	0	Enum8	Write Protect Code (0 - Disabled, 1 - Enabled) Table 7, Spec 183
16	250	Enum8	Reserved. Must be set to 250
17	1	Bit Field	PV Analog Channel Flags (1 - Input Current) Table 26, Spec 183

***Note:**

If compatibility mode is enabled, the value returns units from Cmd 44.

9.5 Command 17: Write Message

Writes a message into the device. This message can be read by Command 12 - Read Message.

Table 10. Request Data Bytes

Byte	Value	Format	Description
0 to 23	---	32 Packed ASCII characters	Message String used by the Master for Record Keeping

Table 11. Response Codes Allowed

Number	Type	Meaning
0	---	Success
5	Error	Too Few Data Bytes Received - Sent when less than 24 request data bytes are received
6	---	Not Used
7	Error	In Write Protect Mode - Sent when the device is in write protect mode
16	Error	Access Restricted
32	Error	Busy

Table 12. Response Data Bytes

Byte	Value	Format	Description
0 to 23	---	32 Packed ASCII characters	Message String that was written to the device

9.6 Command 48: Read Additional Device Status

Returns device status information not included in the response code or device status byte.

See the More Status Bit for working details of More Status within Command 48.

Regardless of the Request Data Byte count, the full Response Data Bytes will always be sent back (unless there is a Communication Error or there is a Too Few Bytes Response Code).

There are two options: either send 0 Request Data Bytes or send the following bytes. See Table 13.

Table 13. Request Data Bytes

Byte	Value	Format	Description
0 to 5	---	Bit Fields	See Alert Enable Mask
6	---	Bit Field	Extended Device Status (See Common Table 17 in Spec 183)
7	---	Bit Field	Device Operating Mode (See Common Table 14 in Spec 183)
8	---	Bit Field	Standardized Status 0 (See Common Table 29 in Spec 183)
9	---	Bit Field	Standardized Status 1 (See Common Table 30 in Spec 183)

Table 14. Response Codes Allowed

Number	Type	Meaning
0	---	Success
5	Error	Too Few Data Bytes - Occurs when more than 0 but less than 10 request data bytes are supplied.
6	---	Not Used
8	---	Not Used
14	Warning	Data Mismatch - Occurs when the correct amount of data bytes is supplied, but the request bytes do not match the current Command 48 status bytes in the device.
16	---	Not Used

Table 15. Response Data Bytes

Byte	Value	Format	Description
0 to 5	---	Bit Fields	See Alert Enable Mask
6	---	Bit Field	Extended Device Status (See Common Table 17 in Spec 183)
6.0	---	Bit	Maintenance Required (NE107)
6.1	---	Bit	Device Variable Alert
6.2	---	Bit	Critical Power Failure
6.3	---	Bit	Failure (NE107)
6.4	---	Bit	Out of Specification (NE107)
6.5	---	Bit	Function Check (NE107)
6.6 to 6.7	0	Bits	Reserved
7	0x00	Bit Field	Device Operating Mode - Reserved by HART Spec, always 0
8	---	Bit Field	Standardized Status 0 (See Common Table 29 in Spec 183)
8.0	---	Bit	Device Variable Simulation Active
8.1	---	Bit	Non-Volatile Memory Defect
8.2	---	Bit	Volatile Memory Defect
8.3	---	Bit	Watchdog Reset Executed
8.4	---	Bit	Power Supply Conditions Out of Range
8.5	---	Bit	Environmental Conditions Out of Range
8.6	---	Bit	Electronic Defect
8.7	---	Bit	Device Configuration Locked
9	---	Bit Field	Standardized Status 1 (See Common Table 30 in Spec 183)
9.0	---	Bit	Status Simulation Active
9.1	---	Bit	Discrete Variable Simulation Active
9.2 to 9.7	0	Bits	Not Used and Reserved

9.6.1 Alert Enable Mask

Table 16.

Byte	Bit	Description
0	0	Travel Deviation
0	1	Instrument Mode
0	2	Supply Pressure Low
0	3	Supply Pressure High
0	4	Stroke Time Close
0	5	Stroke Time Open
0	6	Temperature High
0	7	Temperature Low
1	0	Device Misconfigured
1	1	Cycle Counter High
1	2	Travel Feedback Error
1	3	Travel Accumulator High
1	4	Travel High
1	5	Travel Low
1	6	Diagnostic In Progress
1	7	Port A Over Pressurized Alert
2	0	Travel Limit/Cutoff High Alert
2	1	Travel Limit/Cutoff Low Alert
2	2	Instrument Time Bad Alert
2	3	Calibration In Progress
2	4 to 7	Reserved
3	0 to 7	Reserved
4	0 to 7	Reserved
5	0 to 4	Reserved
5	5	Drive Signal
5	6	Drive Current
5	7	Transmitter Open Circuit

9.7 Common Practice Commands

The DVC7K field device supports the following common practice commands:

Command 33: Read Device Variables

Command 35: Write Primary Variable Range Values

Command 44: Write Primary Variable Units

Command 50: Read Dynamic Variable Assignments

Command 51: Write Dynamic Variable Assignments

Command 52: Set Device Variable Zero

Command 53: Write Device Variable Units

Command 54: Read Device Variable Information

Command 59: Write Number of Response Preambles

Command 72: Squawk

Command 89: Set Real-Time Clock

Command 90: Read Real-Time Clock

Command 95: Read Device Communication Statistics

9.7.1 Burst Mode

This Field Device does not support Burst Mode.

9.7.2 Condensed Status

Command 523: Read Condensed Status Mapping Array

Command 524: Write Condensed Status Mapping

Command 525: Reset Condensed Status Map

Command 526: Write Status Simulation Mode

Command 527: Simulate Status Bit⁽¹⁾

Notes:

1. The instrument will reject an attempt to enter simulation mode if write protection is enabled. Simulation mode will exit automatically in 15 minutes if the instrument is in Automatic or remain indefinitely if the instrument is in Manual. Simulation mode will exit when the instrument is placed in Automatic.
2. Burst Mode not supported by this instrument.

9.8 Command 33: Read Device Variables

This command allows a Master to request the value of up to four Device Variables.

Table 17. Request Data Bytes

Byte	Value	Format	Description
0	---	UInt8	Slot 0: Device Variable Code (0 to 9 and 244 to 249 inclusive)
1 (Optional)	---	UInt8	Slot 1: Device Variable Code (0 to 9 and 244 to 249 inclusive)
2 (Optional)	---	UInt8	Slot 2: Device Variable Code (0 to 9 and 244 to 249 inclusive)
3 (Optional)	---	UInt8	Slot 3: Device Variable Code (0 to 9 and 244 to 249 inclusive)

Table 18. Response Codes Allowed

Number	Type	Meaning
0	---	Success
2	Error	Invalid Selection <ul style="list-style-type: none"> Send when code received is 10 to 243 inclusive Send when code received is greater than or equal to 250
5	Error	Too Few Data Bytes Received <ul style="list-style-type: none"> Send when 0 request data bytes are received

Table 19. Response Data Bytes

Byte	Value	Format	Description
0	---	UInt8	Slot 0: Device Variable Code (see Variable Numbers)
1	---	UInt8	Slot 0: Units Code (see Variable Numbers)
2 to 5	---	Float	Slot 0: Device Variable Value
6 (Optional)	---	UInt8	Slot 1: Device Variable Code (see Variable Numbers)
7 (Optional)	---	UInt8	Slot 1: Units Code (see Variable Numbers)
8 to 11 (Optional)	---	Float	Slot 1: Device Variable Value
12 (Optional)	---	UInt8	Slot 2: Device Variable Code (see Variable Numbers)
13 (Optional)	---	UInt8	Slot 2: Units Code (see Variable Numbers)
14 to 17 (Optional)	---	Float	Slot 2: Device Variable Value
18 (Optional)	---	UInt8	Slot 3: Device Variable Code (see Variable Numbers)
19 (Optional)	---	UInt8	Slot 3: Units Code (see Variable Numbers)
20 to 23 (Optional)	---	Float	Slot 3: Device Variable Value

9.9 Command 35: Write Primary Variable Range Values

In the DVC7K, the Primary Variable is defined to be the Analog Input (loop current).

This command is used to write the ranging values reported in Command 15. It controls how the DVC7K interprets the loop current when creating the Travel Target. The upper range must be greater than the lower range.

This command does units conversion, accepting range values in milliamperes or percent. If the primary variable is not configured to use the same units as supplied in this command, the supplied ranges will be converted to PV units before being applied. Range values are validated against those reported in Command 14 to assure that they are within the allowable range and are separated by a minimum span.

If the range values are in percent, then they are assumed to be percent of 4 to 20 mA. For example, to range an increase to open unit from 8 mA to 16 mA, but using percent range numbers, specify lower_range = 25% and upper_range = 75%.

This ranging is done in conjunction with the zero-power condition. For an Increase-to-Open valve, the lower range is the 0% setpoint level (valve plug in the valve seat), while the upper range is the 100% setpoint level. An Increase-to-Close valve is exactly opposite.

This command will be accepted when the DVC7K Control Mode is in Automatic but will be rejected if Protection is in effect.

Table 20. Request Data Bytes

Byte	Value	Format	Description
0	mA / %	Uint8	Unit code for the limit values in the request. This field will not change the PV unit code in the device.
1 to 4	---	Float	PV Upper Range Value
5 to 8	---	Float	PV Lower Range Value

Table 21. Response Codes Allowed

Number	Type	Meaning
0	---	Success
5	Error	Too Few Data Bytes Received (Sent when less than 9 data bytes are received in the request)
7	Error	In Write Protect Mode (Sent when the device is in write protect mode)
9	Error	Lower Range Too High (Sent when the lower PV Range is greater than 20 mA or 100%)
10	Error	Lower Range Too Low (Sent when the lower PV Range is less than 4 mA or 0%)
11	Error	Upper Range Too High (Sent when the upper PV Range is greater than 20 mA or 100%)
12	Error	Upper Range Too Low (Sent when the upper PV Range is less than 4 mA or 0%)
16	Error	Access Restricted • Power Store is not full
18	Error	Invalid Units Code (Sent when the units code is not 39 or 57)
29	Error	Invalid Span (Sent when the lower PV Range is greater than or equal to the upper PV Range. Also sent when the upper and lower PV Ranges are separated by less than the minimum span in Command 14)
32	Error	Busy

Table 22. Response Data Bytes

Byte	Value	Format	Description
0	mA / %	UInt8	Unit code for the limit values in the response. This does not reflect the unit code associated with PV in the device.
1 to 4	---	Float	PV Upper Range Value
5 to 8	---	Float	PV Lower Range Value

9.10 Command 44: Write Primary Variable Units

Table 23. Request Data Bytes

Byte	Value	Format	Description
0	mA / %	Uint8	New unit code for PV

Table 24. Response Codes Allowed

Number	Type	Meaning
0	---	Success
2	Error	Invalid Selection - Sent when an invalid or unsupported PV Unit Code is sent in the request.
5	Error	Too Few Data Bytes Received - Sent when 0 data bytes are sent in the request.
7	Error	In Write Protect Mode - Sent when the device is in write protect mode.
16	Error	Access Restricted <ul style="list-style-type: none"> Locked by another master
32	Error	Busy

Table 25. Response Data Bytes

Byte	Value	Format	Description
0	mA / %	Uint8	Unit code for PV in the device

9.11 Command 50: Read Dynamic Variable Assignments

Command 50 responds with the Device Variable Codes that are assigned to the Primary, Secondary, Tertiary and Quaternary Variables. The assignments are written using Command 51 - Write Dynamic Variable Assignments and the variables are returned in Command 3 - Read Dynamic Variables and Loop Current. The Field Device must return all Response Data Bytes.

Request Data Bytes: **None**

Table 26. Response Codes Allowed

Number	Type	Meaning
0	---	Success

Table 27. Response Data Bytes

Byte	Value	Format	Description
0	---	UInt8	Device Variable Code assigned to the Primary Variable and returned as the first variable in Command 3 - Read Dynamic Variables and Loop Current
1	---	UInt8	Device Variable Code assigned to the Secondary Variable and returned as the second variable in Command 3 - Read Dynamic Variables and Loop Current
2	---	UInt8	Device Variable assigned to the Tertiary Variable and returned as the third variable in Command 3 - Read Dynamic Variables and Loop Current
3	---	UInt8	Device Variable assigned to the Quaternary Variable and returned as the fourth variable in Command 3 - Read Dynamic Variables and Loop Current

9.12 Command 51: Write Dynamic Variable Assignments

The assignments are written using Command 51 - Write Dynamic Variable Assignments and the variables are returned in Command 3 - Read Dynamic Variables and Loop Current. The Field Device must return all Response Data Bytes. Command 50 responds with the Device Variable Codes that are assigned to the Primary, Secondary, Tertiary and Quaternary Variables.

Table 28. Request Data Bytes

Byte	Value	Format	Description
0	---	UInt8	Device Variable Code assigned to the Primary Variable (MUST BE ZERO)
1 (Optional)	---	UInt8	Device Variable Code assigned to the Secondary Variable (0 to 9 inclusive)
2 (Optional)	---	UInt8	Device Variable Code assigned to the Tertiary Variable (0 to 9 inclusive)
3 (Optional)	---	UInt8	Device Variable Code assigned to the Quaternary Variable (0 to 9 inclusive)

Table 29. Response Codes Allowed

Number	Type	Meaning
0	---	Success
2	Error	Invalid Selection <ul style="list-style-type: none"> Send when Primary Variable received is not zero Send when any one of Secondary, Tertiary or Quaternary Variable is more than 9
5	Error	Too Few Data Bytes Received Send when 0 data bytes are received
7	Error	In Write Protect Mode
16	Error	Access Restricted <ul style="list-style-type: none"> Sent when the device is locked by another master
32	Error	Busy

Table 30. Response Data Bytes

Byte	Value	Format	Description
0	---	UInt8	Device Variable Code assigned to the Primary Variable and returned as the first variable in Command 3 - Read Dynamic Variables and Loop Current
1	---	UInt8	Device Variable Code assigned to the Secondary Variable and returned as the second variable in Command 3 - Read Dynamic Variables and Loop Current
2	---	UInt8	Device Variable assigned to the Tertiary Variable and returned as the third variable in Command 3 - Read Dynamic Variables and Loop Current
3	---	UInt8	Device Variable assigned to the Quaternary Variable and returned as the fourth variable in Command 3 - Read Dynamic Variables and Loop Current

9.13 Command 52: Set Device Variable Zero

This command is used to force one of the pressure inputs to read 0. To use this for pressure, apply 0 psi to the sensor. Then, send this command, specifying the affected pressure Device Variable. The offset will be adjusted to force the present value to read 0. An error will be generated and no change will be applied if the new value causes a change of more than about 3 psi.

Table 31. Request Data Bytes

Byte	Format	Description
0	UInt8	Device variable code - device variable to be zeroed Only the following device variables are allowed to be zeroed: <ul style="list-style-type: none"> • [4] Output Pressure A • [5] Output Pressure B • [6] Supply pressure Note: The span of the pressure sensor corresponding to these variables will not change, i.e., this command will adjust both the low and high calibration values of the specified pressure variable.

Table 32. Response Data Bytes

Byte	Format	Description
0	UInt8	Device variable code - device variable to be zeroed

Table 33. Response Codes

Number	Type	Description
0	---	Success
2	---	Invalid Selection - sent when the wrong device variable code is received or when the device variable cannot be zeroed
5	---	Too Few Data Bytes Received - sent when byte 0 is not received
6	---	Device-Specific Error - sent when the sensor status for the corresponding device variable is not Good
7	---	In Write Protect Mode - sent when the device is in write protect mode
9	---	Present Value Too High <ul style="list-style-type: none"> sent when sensor input too high causing the offset to change by more than 700 counts* sent when sensor input is too high causing the upper range value (high calibration value) to be more than its maximum value (Uint16 Maximum Value = 65535)
10	---	Present Value Too Low - sent when sensor input too low causing the offset to change by more than 700 counts*
16	---	Access Restricted <ul style="list-style-type: none"> sent when the device is locked by another master sent when device is not in MAN mode (i.e., AUTO or LO mode)
32	---	Busy - sent when the write to the NVM fails (Not verified by Automated Test)

* **Note:**
approximately equal to 3 psi

9.14 Command 53: Set Device Variable Units

Sets the units for a device variable.

Only device variables returned by Command 0 (maximum device variable index (byte 13) are able to be changed by Command 53, all other variables return "Invalid Device Variable Code". This does not include dynamic variables PV, SV, TV and QV variables. However, PV is always Loop Current on DVC7K, and Loop Current (Device Variable) is able to be modified by Command 53.

Table 34. Request Data Bytes

Byte	Value	Format	Description
0	---	Uint8	Device Variable Code (see Variable Numbers)
1	---	Enum	Device Variable Units Code

Table 35. Response Data Bytes

Byte	Value	Format	Description
0	---	Uint8	Device Variable Code (see Variable Numbers)
1	---	Enum	Device Variable Units Code

Note:

The value returned in the response data bytes reflects the value actually used by the device.

Table 36. Response Codes Allowed

Number	Type	Meaning
0	---	Success
5	Error	Too Few Data Bytes Received
7	Error	In Write Protect Mode
11	Error	Invalid Device Variable Code
12	Error	Invalid Units Code
16	Error	Access Restricted • Sent when the device is locked by another master
32	Error	Busy

9.15 Command 54: Read Device Variable Information

Table 37. Request Data Bytes

Byte	Value	Format	Description
0	---	Uint8	Device Variable Code - See Device Variables

Table 38. Response Data Bytes

Byte	Value	Format	Description
0	---	UInt8	Device Variable Code - See Device Variables
1 to 3	---	UInt24	Transducer Serial Number 0 - If Not Applicable
4	---	UInt8	Device Variable Limits / Minimum Span Units Code See Device Variables for possible unit codes of each device variable
5 to 8	---	Float32	Device Variable Upper Limit NaN (0x7FA00000) - if not applicable. See Device Variables for upper limit of each device variable
9 to 12	---	Float32	Device Variable Lower Limit NaN (0x7FA00000) - if not applicable. See Device Variables for lower limit of each device variable
13 to 16	---	Float32	Device Variable Damping Value NaN (0x7FA00000) - if not applicable
17 to 20	---	Float32	Device Variable Minimum Span NaN (0x7FA00000) - if not applicable
21	---	UInt8	Device Variable Classification 0 (Not yet implemented) - if not supported by the device variable See Device Variables for classification of each device variables
22	---	UInt8	Device Variable Family 250 (Not used) - if not supported by the device variable
23 to 26	---	UInt32	Update Time Period (as factor of 1/32 of millisecond) (e.g., 320 * 0.03125 ms = 10 ms) See Device Variables for update period of each device variables
27	---	UInt8	Device Variable Properties Bit 0 - Set if Device variable is an input (e.g. written) to the device Bit 1 to Bit 6 - always 0 Bit 7 - Set if device variable is being simulated (always 0 if device variable is not calculated in the device). See Device Variable for properties of each device variable

Table 39. Response Codes

Number	Type	Description
0	---	Success
2	Error	Invalid Selection - Sent when wrong device variable code is sent
5	Error	Too Few Data Bytes Received - sent when device variable code (byte 0) is not received
16	Error	Access Restricted - Not used
32	Error	Busy - Not used

9.16 Command 59: Write Number of Response Preambles

Sets the number of preambles to be sent by the device.

Table 40. Request Data Bytes

Byte	Value	Format	Description
0	5 to 20	Uint8	Number of preambles to be sent with the response message from our device to a master.

Table 41. Response Data Bytes

Byte	Value	Format	Description
0	5 to 20	Uint8	Number of preambles to be sent with the response message from our device to a master.

Table 42. Response Codes Allowed

Number	Type	Meaning
0	---	Success
5	Error	Too Few Data Bytes Received - Sent when 0 request bytes are received.
7	Error	In Write Protect Mode - Sent when the device is in write protect mode.
8	Warning	Set To Nearest Possible Value. If the request bytes are less than 5, the preamble count will be set to 5 and this response code will be set. If the request bytes are greater than 20, the preamble count will be set to 20 and this response code will be set.
16	Error	Access Restricted
32	Error	Busy

9.17 Command 72: Squawk

This command causes the device's LED indicator to cycle through the colors: Green > Blue > Red.

If "On" control code is received, the device will continuously squawk until an "Off" code is received. When the "Squawk Once" code is received, the device shall squawk for 60 seconds. If the device is already squawking from "Squawk Once" code and a new "Squawk Once" code is received, then the squawking shall timeout in 60 seconds from the most recent reception of the squawk command.

Squawking can be stopped by pressing any button on the LUI or by power cycling/resetting the device.

Table 43. Request Data Bytes

Byte	Value	Format
0	Squawk Control: 0 - Off 1 - On 2 - Squawk Once for 60 seconds	Enum-8

Table 44. Response Data Bytes

Byte	Value	Format	Description
0	See Request Byte 0	Enum-8	Squawk Control (see Table 43)

Table 45. Response Bytes

Number	Type	Meaning
0	---	Success
2	Error	Invalid Selection - (Invalid request byte received)

9.18 Command 89: Set Real-Time Clock

This command sets the Real-Time clock in the device.

- If the Time-Set code is 0 then the device will answer with its current date and time. It will not set the Real-Time clock to the requested date and time.
- If the Time-Set code is 1 then the device will answer with the requested date and time value. It will set the Real-Time clock to the requested date and time.

Time-Set Codes:

0 = Read Receive Time

1 = Write Date and Time

Table 46. Request Data Bytes

Byte	Value	Format	Description
0	0 or 1	UInt8	Time-Set Code
1 to 3	---	HART Date	HART Date to set
4 to 7	---	HART Time	HART Time of Day to set
8 to 9	0x0000	UInt8	Should be set to 0. Two bytes to ensure request and response take equal amounts of time. The response always adds two extra bytes for the response code and for the device status. However, nothing will happen if the request is not 0, as these two bytes are ignored.

Table 47. Response Codes Allowed

Number	Type	Meaning
0	---	Success
2	Error	Invalid Selection (Date Code is not 0 or 1 in request byte 0)
5	Error	Too Few Data Bytes Received - Sent when the number of request data bytes are less than 10.
6	Error	Device-Specific Command Error <ul style="list-style-type: none"> • Sent when Internal Time is Invalid AND Time-Set Code = 0
9	Error	Invalid Date Code Detected - Sent when the request data bytes for HART Date are: No Hardware RTC (means that internal core time is being used and there was a failure reading/writing/configuring the HW RTC): <ul style="list-style-type: none"> • Less than January 1, 2000, 12:00:00 am or greater than February 7, 2136, 6:28:15 am Hardware RTC: <ul style="list-style-type: none"> • Less than January 1, 2000, 12:00:00 am or greater than February 7, 2136, 6:28:15 am Also sent when the month or day byte is 0.
16	Error	Access Restricted

Table 48. Response Data Bytes

Byte	Value	Format	Description
0	0 or 1	UInt8	Time-Set Code
1 to 3	---	HART Date	HART Date that was set
4 to 7	---	HART Time	HART Time that was set

9.19 Command 90: Read Real-Time Clock

Request Data Bytes: **None**

Table 49. Response Codes Allowed

Number	Type	Meaning
0	---	Success

Table 50. Response Data Bytes

Byte	Value	Format	Description
0 to 2	---	HART Date	Current HART Date set in the device
3 to 6	---	HART Time	Current HART Time of Day set in the device
7 to 9	---	HART Date	Last HART Date that the clock was set
10 to 13	---	HART Time	Last HART Time of Day that the clock was set
14	---	Bit Field	RTC Flags <ul style="list-style-type: none"> • 0x01 = Non-Volatile Clock - When set, this indicates that the device contains a battery backed clock and/or the time was set and power has not been lost. Will be set to this value when the Instrument Time is Approximate Alert is not active/pending. • 0x02 = Clock Uninitialized - The real-time clock has never been set, time was lost, or a failure occurred within the date and time. Set when the Instrument Time is Approximate Alert is set. See the alert requirement for when it becomes set.

9.20 Command 95: Read Device Communication Statistics

The device maintains statistics for its communication interface. Separate statistics will be stored for messages sent from the wired HART interface and from the BLE interface.

The statistics are reset to zero on power-up and can only be incremented and not reset. All message counts wrap to zero on overflow.

NOTE:

Command 95 sent from wired HART will return the counts for messages sent and received through the wired HART interface only.

NOTE:

Command 95 sent from BLE will return the counts for messages sent and received through the BLE interface only.

Request Data Bytes: **None**

Table 51. Response Codes Allowed

Number	Type	Meaning
0	---	Success
6	Error	Device-specific command error - Not used

Table 52. Response Data Bytes

Byte	Value	Format	Description
0 to 1	---	UInt16	Count of STX messages received by this device
2 to 3	---	UInt16	Count of ACK messages sent from this device
4 to 5	---	UInt16	Count of BACK messages sent from this device

Section 10: Device-Specific Commands

The DVC7K field device supports device-specific commands. However, these device-specific commands require use of the DD and cannot be utilized outside of this controlled environment.

Section 11: Performance

Refer to the DVC7K Digital Valve Controller Instruction Manual ([D104767X012](#)) and Product Bulletin ([D104765X012](#)) for details on the DVC7K performance.

Annex A. Capability Checklist

Manufacturer, Model and Revision	Fisher Controls DVC7K Dev Rev. 1
Device Type	Pneumatic Control Valve Positioner
HART Protocol Revision	7.7
Device Description Available?	Yes
Number and Type of Process Connections	None
Number of Host Connections	Input: Control signal to Loop \pm terminals Output (Optional): Transmitter and/or Two Switches from Out \pm terminals
Number of Dynamic Variables	4
Mappable Dynamic Variables?	Yes. SV, TV and QV are mappable. PV is not.
Number of Device Variables	10
Number of Supported Common Practice Commands	18
Burst Mode?	No
Capture Device Variables?	No
Write Protection?	Yes

This page is intentionally left blank.

 Fisher.com

 Facebook.com/FisherValves

 LinkedIn.com/groups/3941826

 X.com/FisherValves

D104788X012 © 2024 Fisher Controls International LLC. All rights reserved.

Neither Emerson, nor any of its affiliated entities assume responsibility for the selection, use or maintenance of any product. Responsibility for proper selection, use, and maintenance of any product remains solely with the purchaser and end user.

Fisher and FIELDVUE are marks owned by one of the companies in the Emerson business unit of Emerson Electric Co. Emerson and the Emerson logo are trademarks and service marks of Emerson Electric Co. All other marks are the property of their respective owners.

The contents of this publication are presented for informational purposes only, and while every effort has been made to ensure their accuracy, they are not to be construed as warranties or guarantees, express or implied, regarding the products or services described herein or their use or applicability. All sales are governed by our terms and conditions, which are available upon request. We reserve the right to modify or improve the designs or specifications of such products at any time without notice.

Emerson
Marshalltown, Iowa 50158 USA
Sorocaba, 18087 Brazil
Cernay, 68700 France
Dubai, United Arab Emirates
Singapore 128461 Singapore

www.Fisher.com

FISHER™

EMERSON™