

Digital Setpoint Control for Fisher™ FIELDVUE™ DVC6200 and DVC6000 Digital Valve Controllers

1. Digital Valve Controller Setup

A. Electrical Power

Set the digital valve controller to PT-PT or MULTI-DROP.

For example, figure 1 shows the PT-PT/MULTI-DROP switch, which is located on the main electronics board, for the DVC6200 HW2 digital valve controller.

Voltage -- ensure the switch is set in the “MULTI-DROP” position. The current will be fixed around 8.3 mA with a 24 V power source.

Milliamp current -- ensure the switch is set in the “PT-PT” position. Milliamp signal power to the instrument should be set to a value between 6 and 20 mA.

Notes

- Factory default is switch set to PT-PT.
 - For Multi-Drop and 24 V power a LC340 Line Conditioner may be required to ensure quality HART® communications.
 - For Point-to-Point and a milliamp powered system a HF340 HART filter may be required to ensure quality HART communications.
-

Figure 1. PT-PT or MULTI-DROP Selection

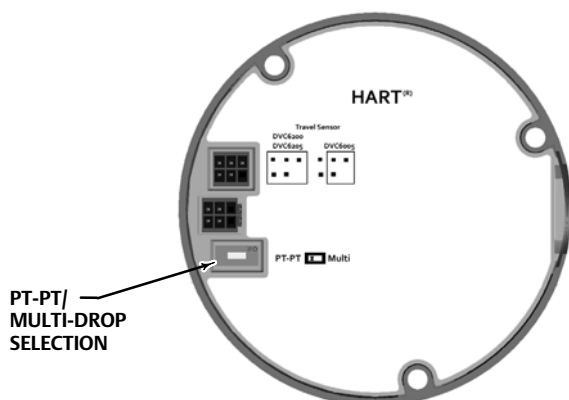

Using a Field Communicator or AMS Device Manager verify or set the following:

- B. Control Mode set to “Digital”
- C. Restart Control Mode set to “Digital”
- D. Instrument mode set to “In Service”

If additional product information is needed refer to Related Documents on page 5.

2. 775 THUM™ Setup

A. Electrical

Wiring diagrams are shown in figure 2.

Notes

- This configuration is only appropriate for one digital valve controller and one THUM adapter.
- The THUM adapter requires up to 2.5 VDC additional compliance voltage above and beyond the digital valve controller requirements.

Figure 2. Wiring Diagrams

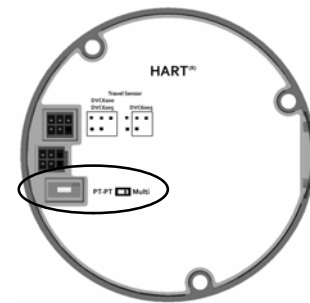
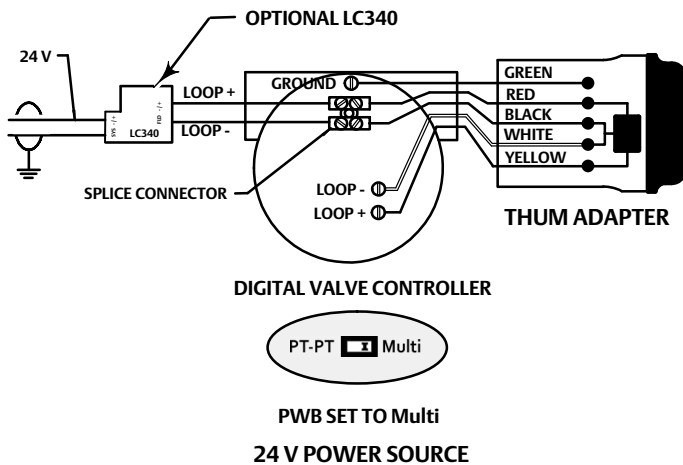

PWB— PT-PT/MULTI SWITCH LOCATION

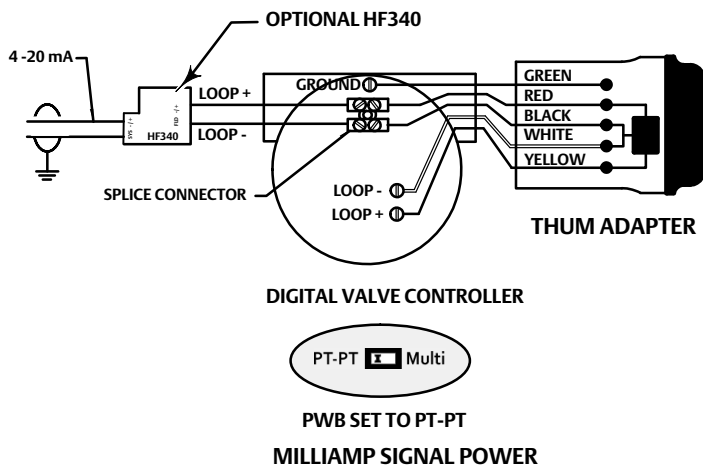

B. Configuration

Using a 775 THUM *WirelessHART*® adapter, map either “PV, SV, TV, QV” or “Process Variable with STATUS”; this allows the Gateway to see TRAVEL_SETPOINT.

3. Wireless Gateway Setup

A. Map TRAVEL_SETPOINT

See figure 3 and 4 for Gateway settings.

Notes

- Requires a Rosemount™ 1410 or 1420 Smart Wireless Gateway version 4.5 or later.
 - Best practice is to use the latest available software or firmware version for all products.
 - Do not map to the THUM adapter.
 - If TRAVEL_SETPOINT does not show up in the drop-down selection box in Modbus or OPC select Run Command Configuration on the THUM and reset update rates.
-

Refer to Annex B of the appropriate HART Field Device Specification supplement for additional information on joining a digital valve controller to a wireless network using the THUM adapter. See Related Documents on page 5.

Figure 3. Mapping TRAVEL_SETPOINT in Modbus

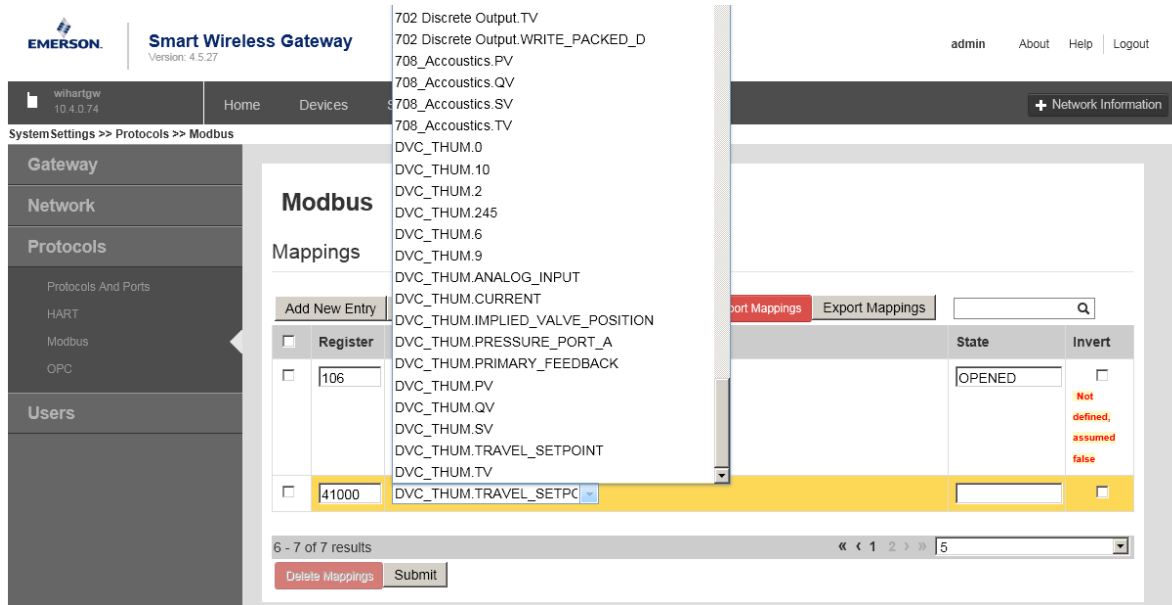
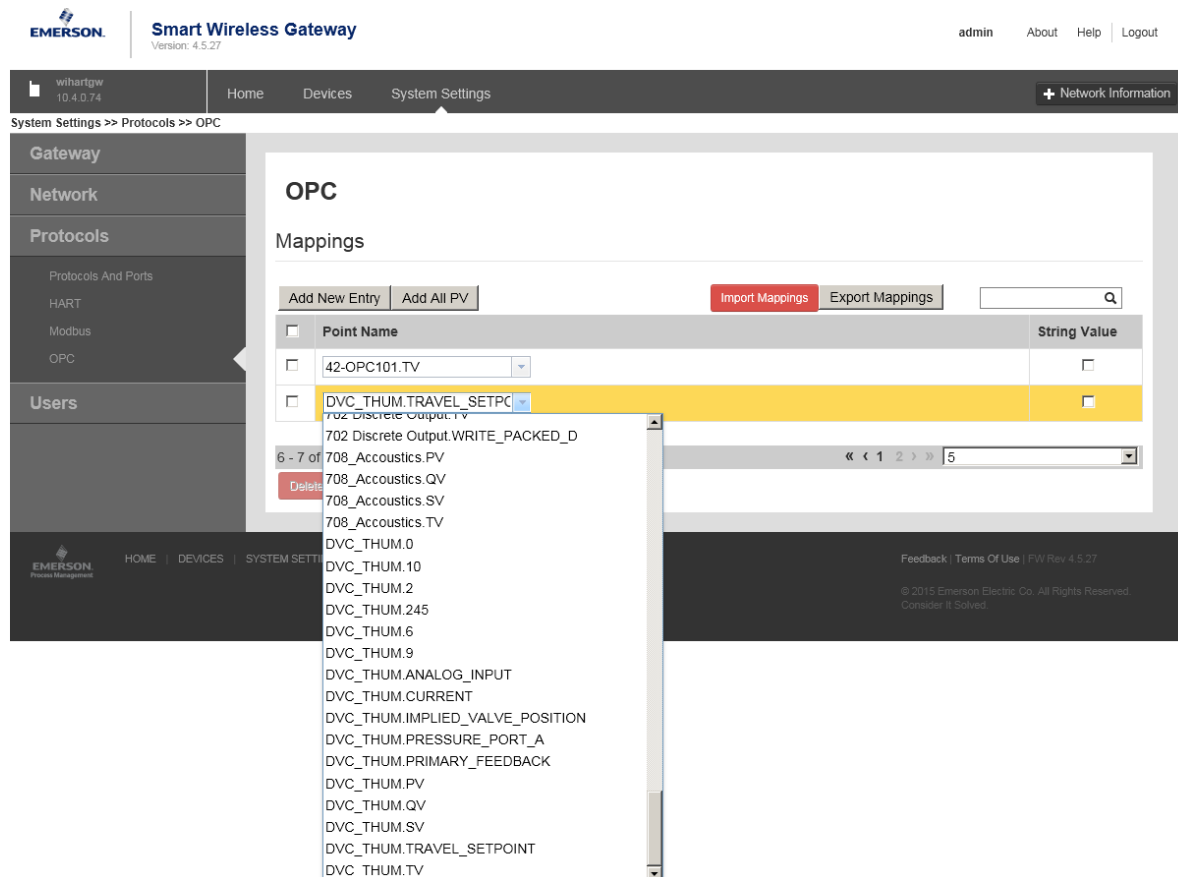

Figure 4. Mapping TRAVEL_SETPOINT in OPC



Related Documents

DVC6200

- DVC6200 Series Digital Valve Controller Quick Start Guide ([D103556X012](#))
- DVC6200 HW2 Digital Valve Controller Instruction Manual ([D103605X012](#))
- HART Field Device Specification for DVC6200 Digital Valve Controller ([D103639X012](#))
- DVC6200 HW1 Digital Valve Controller Instruction Manual ([D103409X012](#))
- HART Field Device Specification for DVC6000 and DVC6200 HW1 Digital Valve Controller ([D103649X012](#))

DVC6000 HW2

- DVC6005 Series Remote Mount Digital Valve Controllers Quick Start Guide ([D103784X012](#))
- DVC6000 HW2 Digital Valve Controller Instruction Manual ([D103785X012](#))
- HART Field Device Specification for DVC6000 HW2 Digital Valve Controller ([D103782X012](#))

DVC6000 (Supported)

- DVC6000 Digital Valve Controllers Instruction Manual ([D102794X012](#))
- HART Field Device Specification for DVC6000 and DVC6200 HW1 Digital Valve Controller ([D103649X012](#))

Miscellaneous

- HF340 Filter Instruction Manual ([D102796X012](#))
- LC340 Line Conditioner instruction manual ([D102797X012](#))

Documents are available from your [Emerson sales office](#) or at Fisher.com.

Neither Emerson, Emerson Automation Solutions, nor any of their affiliated entities assumes responsibility for the selection, use or maintenance of any product. Responsibility for proper selection, use, and maintenance of any product remains solely with the purchaser and end user.

Fisher, FIELDVUE, THUM, and Rosemount are marks owned by one of the companies in the Emerson Automation Solutions business unit of Emerson Electric Co. Emerson Automation Solutions, Emerson, and the Emerson logo are trademarks and service marks of Emerson Electric Co. HART and *WirelessHART* are registered trademarks of the FieldComm Group. All other marks are the property of their respective owners.

The contents of this publication are presented for informational purposes only, and while every effort has been made to ensure their accuracy, they are not to be construed as warranties or guarantees, express or implied, regarding the products or services described herein or their use or applicability. All sales are governed by our terms and conditions, which are available upon request. We reserve the right to modify or improve the designs or specifications of such products at any time without notice.

Emerson Automation Solutions
Marshalltown, Iowa 50158 USA
Sorocaba, 18087 Brazil
Cernay, 68700 France
Dubai, United Arab Emirates
Singapore 128461 Singapore

www.Fisher.com

