

FloBoss™ 107 IEC 62591 Interface

The IEC 62591 Interface allows a FloBoss 107 Flow Manager (“FB107”) to communicate with any mix of up to 20 *WirelessHART*® field devices. The module supports monitoring of both the process information contained in the flow computer and the intelligent diagnostic information residing in the *WirelessHART* field devices. The module can also be used for discrete control applications.

The IEC 62591 Interface consists of two parts: the Emerson Wireless 781S Smart Antenna (“781S”) that provides the radio link to the *WirelessHART* field devices, and the IEC 62591 Interface Module that installs into the FB107.

The IEC 62591 Interface module enables the FB107 to pass HART data bi-directionally through the network to AMS Device Manager software.

WirelessHART Networks

WirelessHART networks provide 99.9% network reliability—reliability that is unmatched by other wireless sensor networks. *WirelessHART* networks achieve this performance by being self-organizing and self-healing mesh networks. This means that each device on the *WirelessHART* network has multiple communication paths and supports automatic path configuration. If one path is obstructed, the network automatically re-organizes and transmits data along another

path to achieve a successful transmission. *WirelessHART* networks ensure that you always have access to the field information when you need it.

Information transmitted on the *WirelessHART* network is protected by 128-bit encryption, user-definable network key, and frequency-hopping spread spectrum radio signals.

Scalability

The IEC 62591 Interface can support up to 20 wireless field devices. Once your initial network has been installed, it is quick and easy to add additional devices, allowing you to plan a large installation and add devices over time. Once a *WirelessHART* device is configured with the Network ID and Join Key, simply install the device in the field and it is automatically detected and reconciled through ROCLINK™ 800 Configuration Software.

WirelessHART Communication Statistics

Detailed communication statistics are accumulated for the wireless network. Transmitted and receive data is accumulated for byte, message, session, tunnel, radio, and other HART messages.

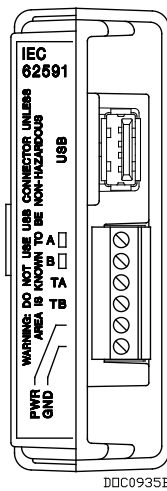

IEC 62591 Interface Module



Emerson Wireless 781S Smart Antenna

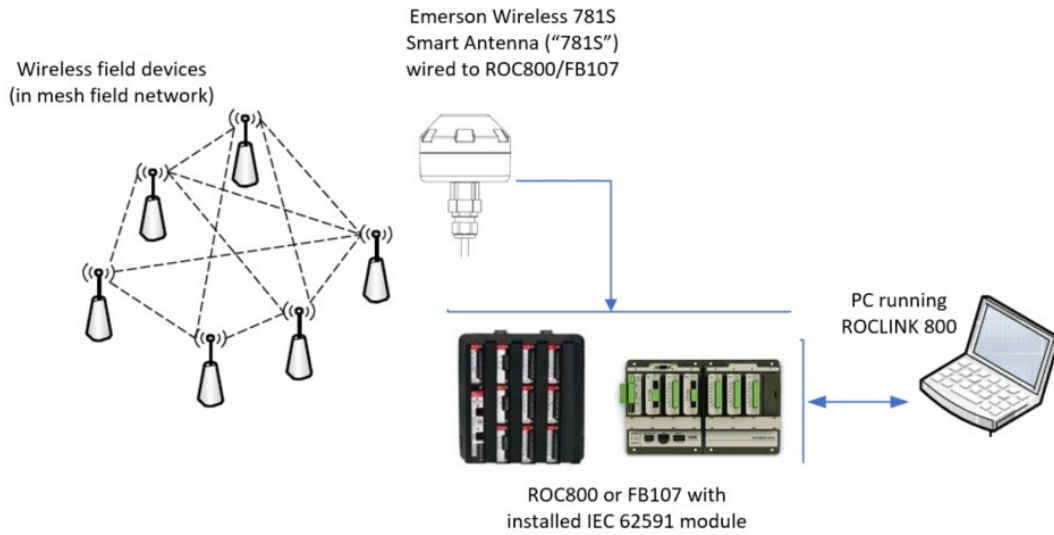

IEC 62591 Interface Self-Organizing Network

WirelessHART Data Access

The IEC62591 Function Block is pre-configured to return the Universal and Common HART parameters including:

- Long Tag
 - User Defined Message
 - User Defined Descriptor
 - Extended Device Type
 - Device ID
 - Manufacturer ID
 - Device Serial Number
 - Adapter Type – THUM’s Expanded Device Type
 - Adapter ID – THUM’s Device ID
 - PV, SV, TV, and QV Variable Units
 - Slot 0, 1, 2 and 3 Variable Units
 - PV, SV, TV, and QV Variable Value
 - Slot 0, 1, 2 and 3 Variable Value
 - Primary Variable Loop Current
 - Device Status
 - Battery Life
- Note:** Battery life is calculated by the transmitter. Refer to the transmitter’s manufacturer for details.
- PV Loop current
 - Burst Rate
 - Variable Status

Installation and Configuration

The IEC 62591 Interface module connects to the 781S through a four-wire connection and provides 12 to 30 Vdc loop- output to power the 781S. This connection allows the 781S to be strategically placed away from the controller in the optimal location for best network performance.

After installing the IEC 62591 Interface module and the 781S, you configure the FB107 with ROCLINK™ 800 Configuration Software to act as a gateway device. The FB107 can then receive signals from and transmit signals to WirelessHART field devices.

ROCLINK 800 provides you with a list of wireless field devices with the correct Network ID and Join Key. You can choose which of those devices are enabled (commissioned) on the network. You can also configure the update rate for individual devices.

You can install one IEC 62591 Interface module in a FB107. IEC 62591 Interface modules can be installed in any slot.

The module has a removable terminal block for convenient wiring and servicing. The terminal block can accommodate size 16 to 24 American Wire Gauge (AWG). A USB port is provided on the module to perform firmware updates and to provide debug information to support personnel.

The module is compatible with FB107 with firmware version 1.85 (or higher) and ROCLINK 800 version 2.62 (or higher).

Tested *Wireless*HART Devices

Note: The IEC 62591 Wireless Interface Module is designed to return the process and dynamic variables (PV, SV, TV, QV, SLOT 0, 1, 2, 3) from any device which meets the IEC 62591 specification (HCF_SPEC-285, Revision 2.0). The following table lists the devices which Emerson has tested and supports with the interface. If you have a *Wireless*HART device which does not appear in the table, consult with the manufacturer of the device to determine whether the process variable values you want to collect are available through the PV, SV, TV, QV, and SLOT 0, 1, 2, and 3. If the device meets the discrete control specification, it should work with the IEC 62591 Wireless Interface; alternatively, it may be treated like an analog wireless device. Always test any *Wireless*HART devices not listed in table to see whether they work with the IEC 62591 Wireless Interface before you install them in the field. Also, always check with Remote Automation Solutions Lifecycle Services to verify that the firmware version of your device is supported in the IEC 62591 Wireless Interface.

Manufacturer	Model	Manufacturer	Model
Rosemount	248 Wireless Temperature Transmitter	Emerson	Wireless 775 THUM Adapter and 8732EM
Rosemount	648 Wireless Temperature Transmitter	Rosemount	2160 Wireless Vibrating Fork Liquid Level Switch
Emerson	Wireless 775 THUM Adapter (tested with 3051)	Rosemount	3308 Wireless Guided Wave Radar Transmitter
Rosemount	3051 Wireless Pressure Transmitter	Rosemount	702 Wireless Discrete Transmitter
Rosemount	2051 Wireless Pressure Transmitter	Rosemount	WPG45 Wireless Pressure Gauge
Rosemount	708 Wireless Acoustic Transmitter	Fisher	4320 Wireless Position Monitor (firmware revision 5.0 or greater)
Rosemount	705 Wireless Totalizing Transmitter	TopWorx	4310 Wireless Position Monitor (firmware revision 5.0 or greater)
Rosemount	928 Wireless Gas Monitor	Emerson	AMS 9420 Wireless Vibration Transmitter

Notes:

- IEC62591 Interface Module v1.24 or greater is required to support all devices.
- Each THUM adapter supports **only one** wired HART device. The maximum number of THUM devices cannot exceed the maximum number of supported wireless devices. Refer to Emerson’s *Wireless THUM™ Adapter Quick Start Guide*, 00825-0100-4075, for further information.

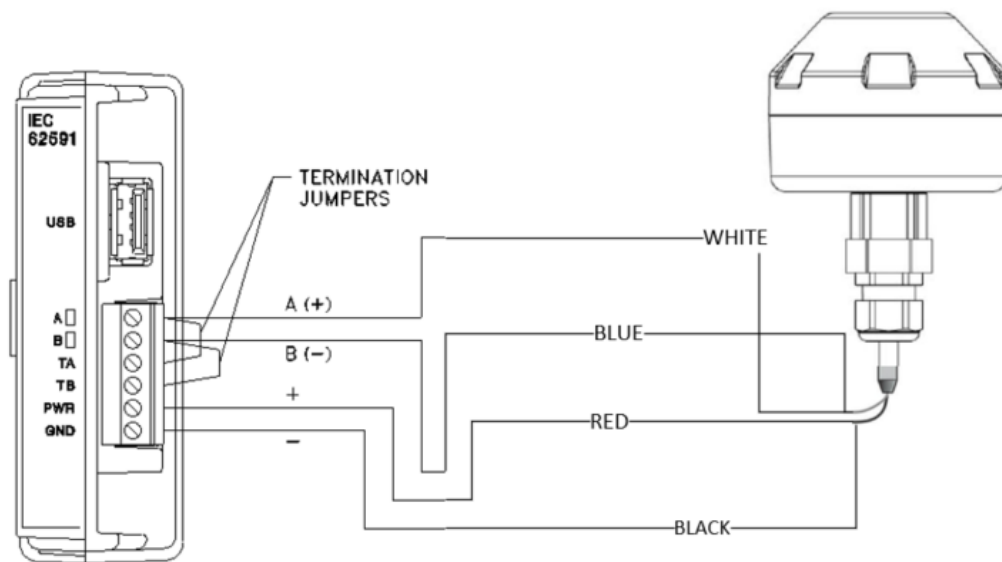

IEC 62591 Module Power and Data Wiring to 7815

Emerson Wireless 781S Smart Antenna

Field Wiring Terminals

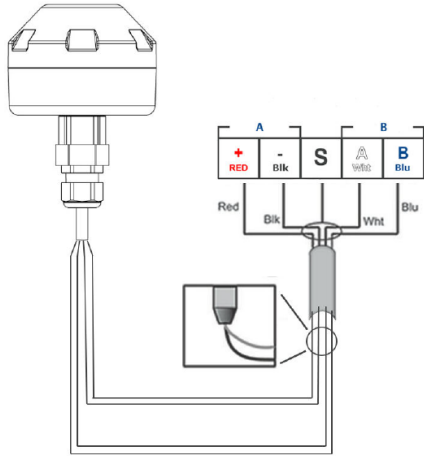

781 Power and Data Wiring

Terminal	Label	Definition
1	A (+)	RS-485 (+)
2	CONNECT	Termination
3	CONNECT	Termination
4	B (-)	RS-485 (-)
5	HART +	HART Configurator
6	HART/POWER -	Input Power Negative
7	POWER +	Input Power Positive

Wireless Communications

Protocol	IEC 62591 (<i>WirelessHART</i> ®) 2.4–2.5 GHz DSSS
Supported Device Update Rates	1 second to 60 minutes Active Advertising support enable for 30 minutes
Network Size/Latency	100 <i>WirelessHART</i> devices at a burst rate of 8 seconds or higher 50 <i>WirelessHART</i> devices at a burst rate of 4 seconds 25 <i>WirelessHART</i> devices at a burst rate of 2 seconds 12 <i>WirelessHART</i> devices at a burst rate of 1 second
Range (Line of Sight)	Internal Antenna 800 m (2625 ft)
Security	AES-128 encrypted <i>WirelessHART</i> , including individual session keys Unique join keys and device listing
Output Power	10 dBm (10mW)

Wired Communications

Type	4-wire connection to the IEC 62591 Interface module Less than 15 pF/ft capacitance
Distance	400 m (1312 ft) maximum; 9 m (30 ft) of Belden 3084a attached to 781S

Power

Input	Supplied by the 4-wire connection to the IEC 62591 Interface module (10.5 – 30 Vdc)
Consumption	20 mA at 12 Vdc

Physical

Dimensions	Diameter 9.4 cm (3.7 in)
Weight	1.1 kg (2.4 lb)
Wiring	22 – 24 AWG twisted shielded pair
Mounting	All SST, 2-inch pipe mounting and panel mount bracket

Environmental

Operating Temperature	-40° C to +85° C (-40 °F to +185 °F)
Operating Humidity	0 to 99% non-condensing relative humidity

EMC	Complies with EN613261:2006	
Approvals		
Ordinary Location Certification	As standard, the device has been examined and tested to determine that the design meets the basic electrical, mechanical, and fire protection requirements by a nationally recognized test laboratory (NRTL) as accredited by the Federal Occupational Safety and Health Administrator (OSHA).	
Installing Equipment in North America	The US National Electrical Code® (NEC) and the Canadian Electric Code (CEC) permit the use of Division-marked equipment in Zones and Zone-marked equipment in Divisions. The markings must be suitable for the area classification, gas, and temperature class. This information is clearly identified in the respective codes.	
USA: I5 USA Intrinsic Safety	Certificate	80011697
	Markings	Class I, Division 1, 2, Groups A, B, C, D T4 (–40 °C ≤ Ta ≤ +70 °C); Class I Zone 0, AEx ia IIC T4; Class I Zone 2, AEx ic IIC T4
	Standards	FM 3600:2011, FB 3610:2018, FM 3611:2018, ANSI/UL 60079-0:2019, ANSI/UL 60079-11:2014
	Warnings/ Conditions of Acceptability	<ol style="list-style-type: none"> 1. Potential electrostatic charging hazard– see instructions. 2. Installed as per Rosemount Control drawing 01410-1300 for hazardous and non-hazardous areas. 3. When not installed with the 1410S (CSA Certificate #80009647), the associated apparatus is required to have a minimum of 114R(Ro) output resistance for RS-485/power connections.
Canada: I1 Canada Intrinsic Safety	Certificate	80011697
	Markings	Class I, Division 1, 2, Groups A, B, C, D T4 (–40 °C ≤ Ta ≤ +70 °C); Ex ia IIC T4; Ex ic IIC T4
	Standards	CAN/CSA C22.2 No. 60079-0:2019, CAN/CSA C22.2 No. 60079-11:2014, CSA C22.2 No. 213–2017
	Warnings/ Conditions of Acceptability	<ol style="list-style-type: none"> 1. Potential electrostatic charging hazard – see instructions. Avertissement – risqué d'explosion: Ne pas débrancher pendant que le circuit est sous tension, 2. Installed as per Rosemount Control drawing 01410-1300 for hazardous and non-hazardous areas. 3. When not installed with the 1410S (CSA Certificate #80009647), the associated apparatus is required to have a minimum of 114R(Ro) output resistance for RS-485/power connections.
Europe: I1 ATEX Intrinsic Safety	Certificate	SGS20ATEX0038X
	Markings	Ex ia IIC T4 Ga (–40 °C ≤ Ta ≤ +70 °C)
	Standards	EN IEC 60079-0:2018, EN 60079-11:2012
	Special Conditions for Safe Use (X)	<ol style="list-style-type: none"> 1. The plastic enclosure may constitute a potential electrostatic ignition risk and must not be rubbed or cleaned with a dry cloth. 2. The equipment is not capable of withstanding the 500 V electrical strength test as defined in clause 6.1.13 of EN 60079-11:2012. This must be taken into account during installation. 3. The measured capacitance between the equipment enclosure and metallic conduit adapter is 21pF. This must be considered only when the Model 781S is integrated into a system where the process connection is not grounded.

Europe: ATEX Intrinsic Safety	Certificate	SGSATEX0053X
	Markings	Ex ic IIC T4 Gc (−40 °C ≤ Ta ≤ +70 °C)
	Standards	EN IEC 60079-0:2018, EN 60079-11:2012
	Special Conditions for Safe Use (X)	<ol style="list-style-type: none"> 1. The plastic enclosure may constitute a potential electrostatic ignition risk and must not be rubbed or cleaned with a dry cloth. 2. The equipment is not capable of withstanding the 500 V electrical strength test as defined in clause 6.3.13 of EN 60079-11:2012. This must be taken into account during installation. 3. The measured capacitance between the equipment enclosure and metallic conduit adapter is 21pF. This must be considered only when the Model 781S is integrated into a system where the process connection is not grounded.
International: I7 IECEx Intrinsic Safety	Certificate	IECEX BAS.20.0021X
	Markings	Ex ia IIC T4 Ga (−40 °C ≤ Ta ≤ +70 °C), Ex ic IIC T4 Gc (−40 °C ≤ Ta ≤ +70 °C)
	Standards	IEC 60079-0:2017, IEC 60079-11:2011
	Special Conditions for Safe Use (X)	<ol style="list-style-type: none"> 1. The plastic enclosure may constitute a potential electrostatic ignition risk and must not be rubbed or cleaned with a dry cloth. 2. The equipment is not capable of withstanding the 500 V dielectric strength test as defined in clause 6.3.13 of IEC 60079-11:2011. This must be taken into account during installation. 3. The measured capacitance between the equipment enclosure and metallic conduit adapter is 21pF. This must be considered only when the Model 781S is integrated into a system where the process connection is not grounded.
Combination Certification	KL Combination of I5, I6, I1, and I7	
Related Documentation		
<ul style="list-style-type: none"> ▪ Emerson Wireless 781S Smart Antenna Quick Start Guide, 00825-0700-4410, Rev AB, October 2020 ▪ Emerson Wireless 1410S Gateway with 781S Smart Antenna Product Data Sheet, 00813-0600-4410, Rev AC, May 2021 ▪ Emerson Wireless 1410S Gateway and 781S Smart Antenna Reference Manual, 00809-06000-4410, Rev AA, September 2020 		

FloBoss 107 IEC 62591 Interface Module

Field Wiring Terminals

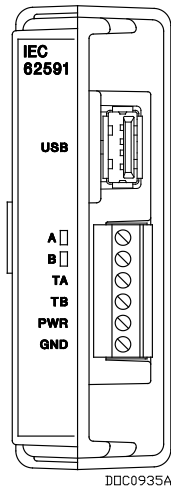

Terminal	Label	Definition
USB	USB	USB 2.0
1	A	RS-485 (+)
2	B	RS-485 (-)
3	TA	Termination A
4	TB	Termination B
5	PWR +	Output Power (+)
6	PWR -	Output Power (-)

Communications

Quantity	1
Type	4-wire connection to the Emerson Wireless 781S Smart Antenna
Max. Number of Wireless Field Devices per Module	20
Max. Number of Modules per FB107	1

USB Port

Quantity	1
Type	USB 2.0 specification
Use	Firmware upgrades and troubleshooting report
	<div style="border: 1px solid red; padding: 2px; display: inline-block;"> Warning </div> Do not use USB connector unless the area is known to be non-hazardous.

Power

Loop Output Power	12 to 30 Vdc		
Consumption	Main power supply loading at the Battery Terminals (at 12.0 Vdc)	Typical	79 mA at 12 Vdc
	Additional loading that may apply	USB Connection	25 mA at 12 Vdc

Physical

Dimensions	26 mm W by 75 mm H by 133 mm D (1.03 in. W by 2.96 in. H by 5.24 in. D)
Weight	113 g (4.0 oz)
Wiring	16 – 24 AWG twisted shielded pair
LEDs	RS-485 transmit and receive

Environmental

Same as the FB107 in which it is installed.

Approvals

Same as the FB107 in which it is installed (with the exception of ATEX certification).

For customer service and technical support, visit www.Emerson.com/SupportNet

**Global Headquarters,
North America, and Latin America:**

Emerson Automation Solutions
Remote Automation Solutions
6005 Rogerdale Road
Houston, TX 77072 U.S.A.
T +1 281 879 2699 | F +1 281 988 4445
www.Emerson.com/RemoteAutomation

Europe:

Emerson Automation Solutions
Remote Automation Solutions
Unit 1, Waterfront Business Park
Dudley Road, Brierley Hill
Dudley DY5 1LX UK
T +44 1384 487200

Middle East/Africa:

Emerson Automation Solutions
Remote Automation Solutions
Emerson FZE
P.O. Box 17033
Jebel Ali Free Zone – South 2
Dubai U.A.E.
T +971 4 8118100 | F +971 4 8865465

Asia-Pacific:

Emerson Automation Solutions
Remote Automation Solutions
1 Pandan Crescent
Singapore 128461
T +65 6777 8211 | F +65 6777 0947

© 2012–2021 Remote Automation Solutions, a business unit of Emerson Automation Solutions. All rights reserved.

This publication is for informational purposes only. While every effort has been made to ensure accuracy, this publication shall not be read to include any warranty or guarantee, express or implied, including as regards the products or services described or their use or applicability. Remote Automation Solutions (RAS) reserves the right to modify or improve the designs or specifications of its products at any time without notice. All sales are governed by RAS terms and conditions which are available upon request. RAS accepts no responsibility for proper selection, use or maintenance of any product, which remains solely with the purchaser and/or end-user.