

Selection Guide for Filter Regulators (FR)

Table of Contents

Section 1: Overview	1
1.1 Purpose.....	1
1.2 Filter Regulators (FR) or Air Preparation Units	1
Section 2: Typical Performance Characteristics	5
Section 3: Dehydrator, Molecular Sieve Desiccant.....	6
Section 4: Regulators (R) or the Combination Filter Regulators (FR)	7
Section 5: Calculating the Size of a Regulator.....	8

Section 1: Overview

1.1 Purpose

This manual provides a guideline for Valve Operating System (VOS) engineering on selection of the Filter Regulators.





1.2 Filter Regulators (FR) or Air Preparation Units

Filter Regulators (FR) or Air Preparation units are essential for installation/control systems, therefore the correct functionality is very important.

It is observed that the size and the installation of valves, fittings and others in a control systems are carefully engineered, but the Filter Regulators (FR) seldom get the same importance even though this element is equally necessary for a good functionality and service life duration of the installed Valve Operating System (VOS), including the actuator.

1.2.1 The following standard schematic symbols are used for Filter Regulator (FR).
See Table 1:

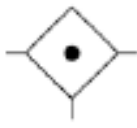
Table 1. Air Preparation Units Symbol Chart

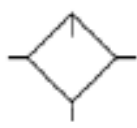
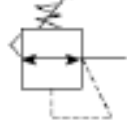
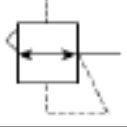
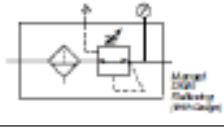
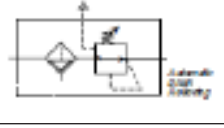
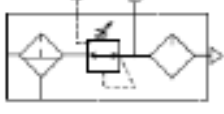
Symbol	Description
	FILTER/SEPARATOR with manual drain
	FILTER/SEPARATOR with automatic drain
	OIL REMOVAL FILTER (coalescing filter)
	AUTOMATIC DRAIN
	LUBRICATOR with manual drain
	AIR LINE PRESSURE REGULATOR adjustable, relieving
	AIR LINE PRESSURE REGULATOR pilot controlled, relieving
	FILTER/REGULATOR (PIGGYBACK) Manual Drain Relieving (With Gauge)
	FILTER/REGULATOR (PIGGYBACK) Auto Drain Relieving
	AIR LINE COMBO F-R-L SIMPLIFIED

1.2.2 The choice of Filter Regulator (FR) depends on the following parameters:

- a. Capacity (C_v value)
- b. Inlet and outlet pressure
- c. Materials used
- d. Self-relieving
- e. Ambient temperature
- f. Filter size (mass size in microns)
- g. Filter drain - manual or automatic or semi automatic
- h. Pressure gauge
- i. Bowl capacity with or without viewing window

1.2.3 Why are the above parameters so important?:

- a. Too small or too big, if sized incorrectly, the actuator will not open or close at the accepted time. Also, the bigger the Filter Regulator (FR), the higher the price.
- b. Determination of the flow rate of Filter Regulator (FR) is a key.
- c. Making a suitable choice of the Filter Regulator (FR) to work for a specified ambient conditions and operating pressures ⁽¹⁾.
- d. Customer preference for relief valves; install a relief valve with at least equal C_v of a Filter Regulator's (FR) C_v .
- e. Filter Regulator (FR) selection based on expected flow requirements.
- f. Depending on the control components and factory recommendations.
- g. Service capacity related and expected debris amount.
- h. Customer preference (specified Filter Regulator (FR)).

NOTE:

⁽¹⁾ A customer preference (hardly specified in project specifications in general) could decrease the service life time of the Valve Operating System (VOS) if other parameters are not explained to the customers in conjunction with other key parameters.

1.2.4 Filtration

1. Compressed air must be dry to prevent ice buildup.
2. Maximum of 40 micron particle size in the air system is acceptable, but when in combination with the Positioners like DVC, 5 micron particle size is required and the recommended lubrication content shall not exceed 1 PPM.
(source, Fisher_ FIELDVUE_ DVC6200)
3. Selection criteria of the filter:
 - a. Determine the maximum flow.
 - b. Determine the maximum allowable pressure drop at the maximum flow rate.

— With reference to the flow chart below (the size and execution could be different per project), choosing the drop at the maximum recommended flow rate is to an allowable ΔP of 2 psi (0.14 bar) but not higher than 5 psi (0.35 bar).

NOTE:

The finer the filter, the lower the capacity and a higher total ΔP over the filter.

Figure 1 Performance Characteristics for 20 Micron Element

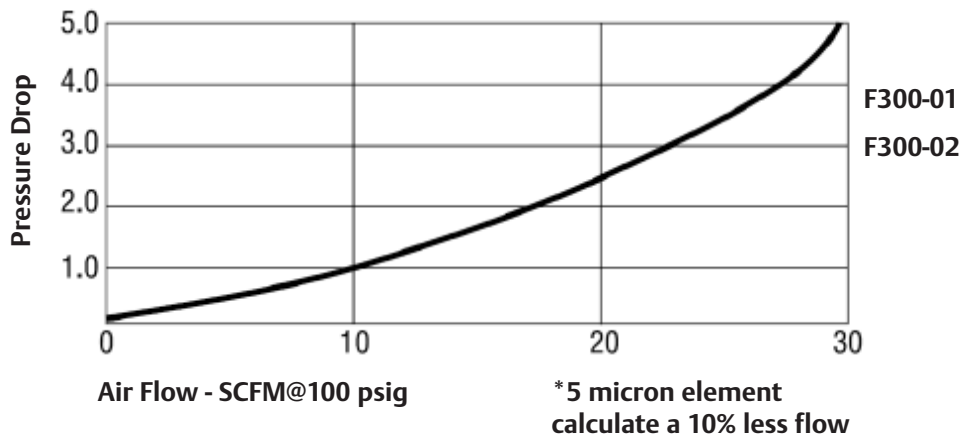

Sources: Fisher and Arrow Filters

Section 2: Typical Performance Characteristics

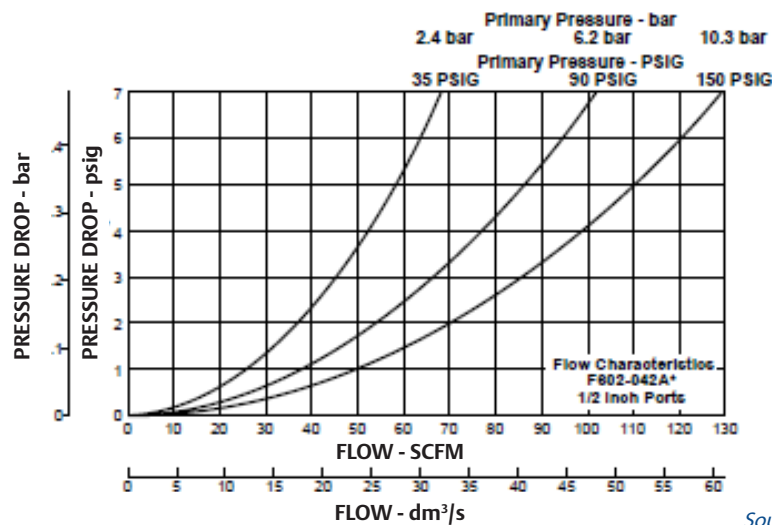
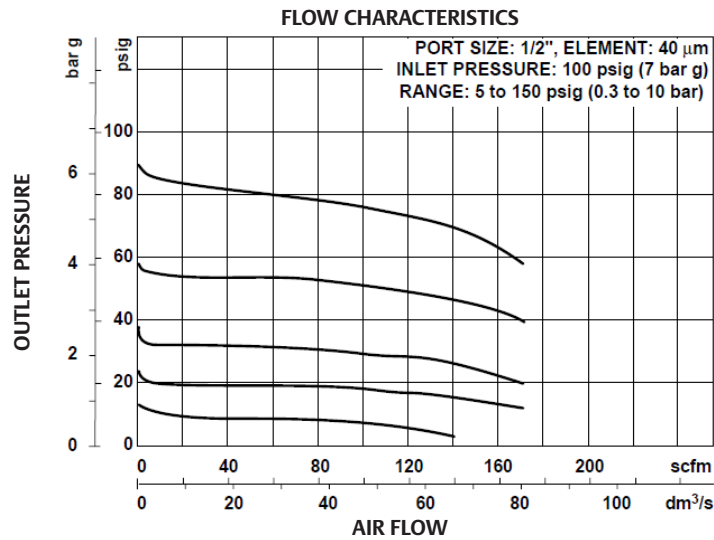
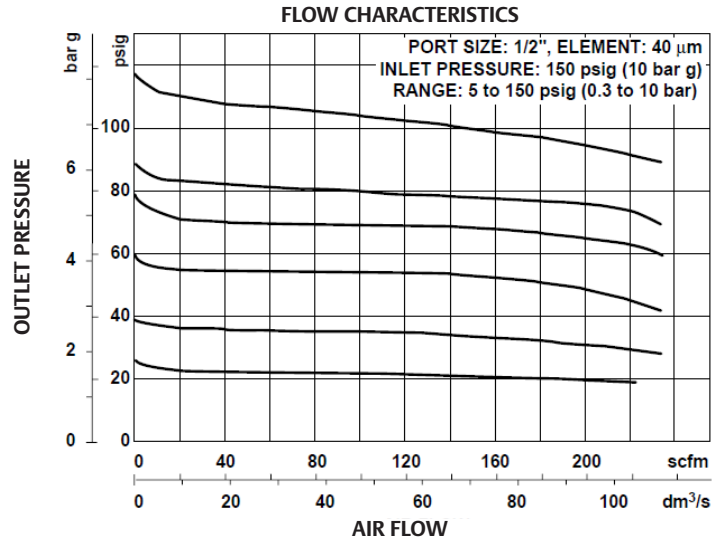

Source: Norgren Filter regulators

Section 3: Dehydrator, Molecular Sieve Desiccant

This is mostly used in natural gas operated systems and installed at the high-pressure side, that is before the Filter Regulator (FR).

This element is highly recommended to be installed in a gas-operated systems where the customer cannot guarantee the purity of the gas in accordance to system specifications.

3.2.1 Some issue will arise, such as:

- Issues in effectively absorbing water and hydrogen sulfide (H²S)
- The dehydrator, molecular sieve must have a capacity that is higher than the Filter Regulator (FR) or filter booster which is installed downstream.

NOTE:

The gas composition must be determined to be able to select the correct dehydrator and the molecular sieve.

A gas chromatograph is the recommended instrument to determine the gas composition.

3.2.2 Advantages of installing a dehydrator, molecular sieve:

- Reduces the risk of hydrate formation
- Reduces the risk of power gas supply (freeze off)

Below is a typical schematic of a Power Gas Application.

Figure 2 Typical Schematic of a Power Gas Application

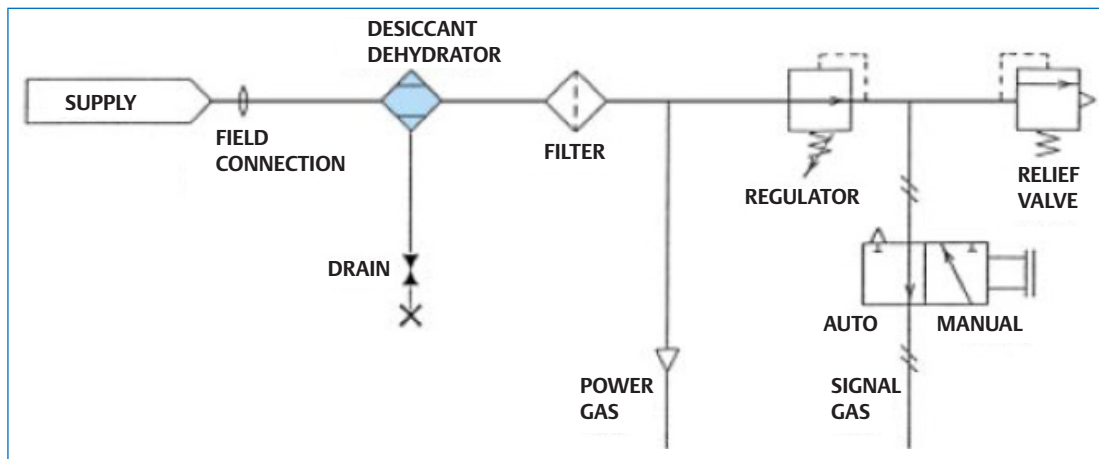

Section 4: Regulators (R) or the Combination Filter Regulators (FR)

Regulators (R) or the combination Filter Regulators (FR) are designed to provide a quick response and an accurate pressure regulation downstream.

Steps to determine the size of a regulator (Regulators (R) or Filter Regulators (FR)), are the same steps to be followed to determine the size of the Filters.

Key parameters to be considered while sizing the regulators (Regulators (R) or Filter Regulators (FR)):

- c. It could be used mostly in both applications of compressed air or natural gas, but needs to be indicated while designing the control system.
- d. Ambient temperature and maximum inlet pressure.
For example: ASCO Modulair 160, maximum inlet pressure at +23°C is 17.5 bar and +50°C at 12 bar.
- e. See example flow chart in Figure 3 below and the different flow capacities versus different upstream and downstream pressures.

NOTE:

The C_v (1/2" C_v 4.3) mentioned in Figure 3 could be misleading. This is a given flow at the ideal set point upstream versus downstream pressures and a filter of 25 microns.

Figure 3 1/2 NPT Regulator Flow Curves

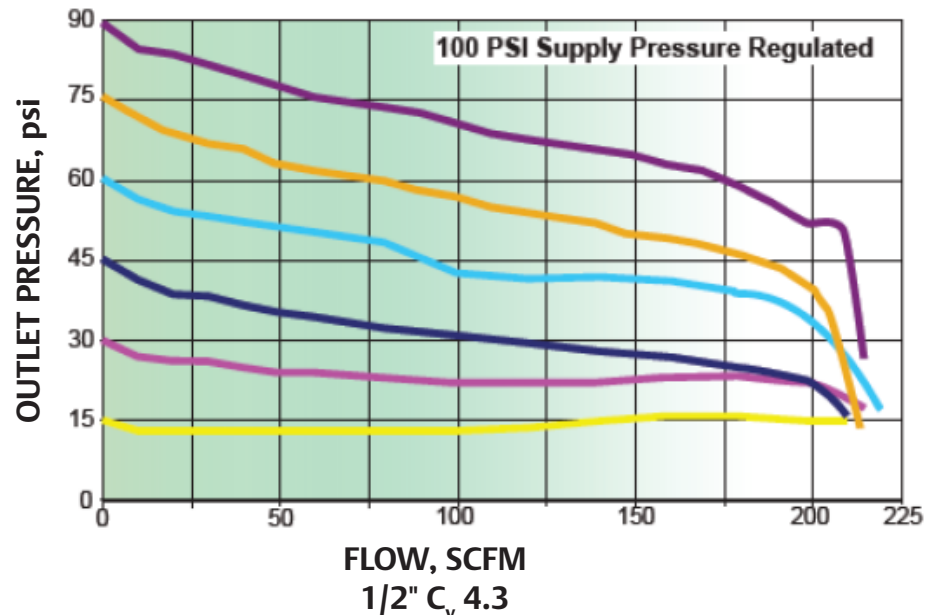

Source: Versa

Section 5: Calculating the Size of a Regulator

Calculating the size of a regulator is as follows:

1. Determine the minimum operating pressure of the actuator and the resistance in pneumatic circuit first. This is also known as the conductance (C_v values) of the elements that will be installed between downstream of the regulator and the actuator.
2. If the pressure loss over the control system plus the minimum actuator operating pressure is determined (which is the pressure needed to generate the minimum operating torque, inclusive the safety factor), the sum of both will be the output pressure of the Filter Regulator (FR).
3. Determine the consumption of the actuator in open (clockwise model actuator) or close (counterclockwise model actuator) to ensure that the capacity of the Filter Regulator (FR) is sufficient. Ensure to bring the total consumption to the amount per minute, that is the expected minimum operations of the actuator within 60 seconds (equal to the SCFM or LPM).

Sample calculation:

1. G4020-SR3-CW (volume: 3277 cubic inch).
2. Actuator is sized with a minimum operating pressure of 60 psi (mostly specified as actuator's minimum operating pressure) and customer air supply pressure is 100 psi.
3. Expected downstream pressure loss over the control components is 5 psi.
4. Operating speed is 15 seconds to open.
5. 10% less flow during operations within 60 seconds.
6. Ambient temperature -15°C to +60°C.

Solution:

- a. Determine the CFM of the actuator
(1 cubic inch per second to cubic feet per minute = 0.0347)
- b. $3277/15 = 218.47$ cubic inch per second = 7.60 CFM
- c. At 60 psi = $(60+5) \times 7.60 = 494$ SCFM (or 29,460 SCFH)
at an average ambient temperature +68°F > + 20°C
- d. The consumption of the actuator and the minimum operating pressure is known. In general, the maximum pressure loss over the control system is determined at 5 psi, hence, the Filter Regulator (FR) must be set on a minimum downstream pressure of 65 psi.
- e. The capacity of the Filter Regulator (FR) can be determined, this will bring to a 1-1/2" high. Refer to Figure 4.

NOTE:

There are two different pressure drops:

- 1.) The set pressure of the regulator, that is the air supply pressure and the VOS pressure .
- 2.) The pressure drop caused by the contamination in the supply air.

Ideal pressure drop over the Filter Regulator (FR) is 2 psi to maximum 5 psi (the lower the ΔP allowable, the quicker the filter needs to be serviced).

Figure 4 Relief and Flow Characteristics

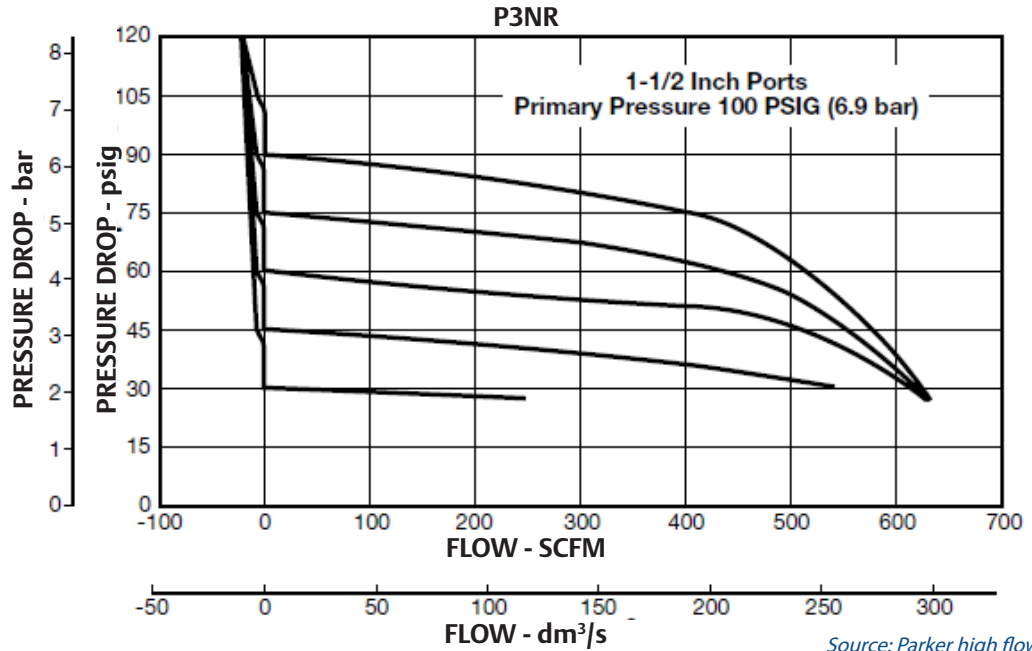
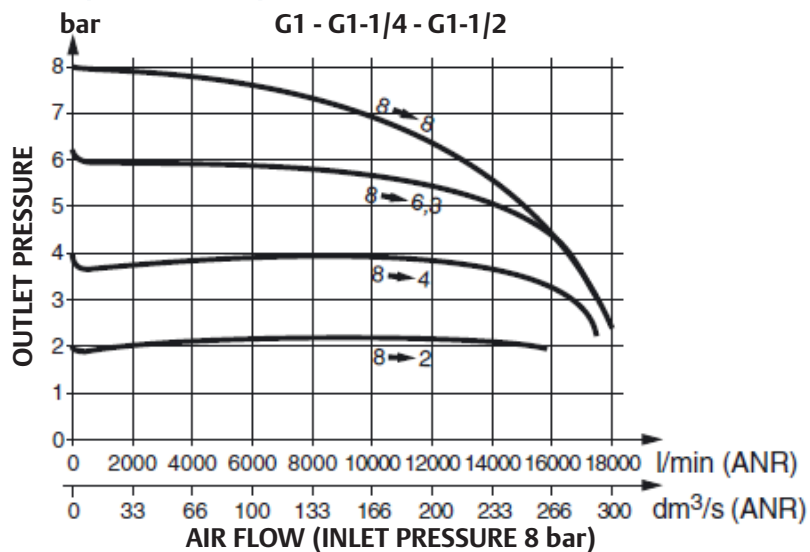

Figure 5 Example of Flow Capacities with Different Inlet and Outlet Pressures



NOTE:

1. 494 SCFM > 13990 l/min.
2. Maximum filter mass size 30 microns

NOTE:

1. When sizing the Filter Regulator (FR) combination, two elements are to be considered: the Regulator and the Filter. Regarding the eventual losses in the control system before the actuator, it is determined that the acceptable losses between the Filter Regulator (FR) and actuator must not be higher than 4 psi (maximum of 5 psi).
 2. Refer to the recommendations for the air quality for the DVC or in general, for the digital controllers to provide reasonable service life of these components. It is recommended that if the controller does not have an internal filter, then install a small in-line filter of 5 to 10 microns in the controller supply line.
 3. When the Filter Regulator (FR) becomes larger than 1/2", consider the use of a Filter Booster (which is a proportional valve) which allows for:
 - a. Smaller Filter Regulator (FR), only needed in the control line to the Filter Booster.
 - b. Smaller Solenoid valve(s).
 4. In case the customer has specified high content of a water in their air, or the natural gas supply, a dehydrator or coalescing filters shall be considered.
-

Conclusion: Information given above suggests that the Filter Regulator (FR) needs to receive more importance when the engineer sizes the actuator control systems.

World Area Configuration Centers (WACC) offer sales support, service, inventory and commissioning to our global customers. Choose the WACC or sales office nearest you:

NORTH & SOUTH AMERICA

19200 Northwest Freeway
Houston TX 77065
USA
T +1 281 477 4100

Av. Hollingsworth
325 Iporanga Sorocaba
SP 18087-105
Brazil
T +55 15 3413 8888

ASIA PACIFIC

No. 9 Gul Road
#01-02 Singapore 629361
T +65 6777 8211

No. 1 Lai Yuan Road
Wuqing Development Area
Tianjin 301700
P. R. China
T +86 22 8212 3300

MIDDLE EAST & AFRICA

P. O. Box 17033
Jebel Ali Free Zone
Dubai
T +971 4 811 8100

P. O. Box 10305
Jubail 31961
Saudi Arabia
T +966 3 340 8650

24 Angus Crescent
Longmeadow Business Estate East
P.O. Box 6908 Greenstone
1616 Modderfontein Extension 5
South Africa
T +27 11 451 3700

EUROPE

Holland Fasor 6
Székesfehérvár 8000
Hungary
T +36 22 53 09 50

Strada Biffi 165
29017 Fiorenzuola d'Arda (PC)
Italy
T +39 0523 944 411

For complete list of sales and manufacturing sites, please visit www.emerson.com/actuationtechnologieslocations or contact us at info.actuationtechnologies@emerson.com

www.emerson.com/bettis

©2018 Emerson. All rights reserved.

The Emerson logo is a trademark and service mark of Emerson Electric Co. Bettis™ is a mark of one of the Emerson family of companies. All other marks are property of their respective owners.

The contents of this publication are presented for information purposes only, and while every effort has been made to ensure their accuracy, they are not to be construed as warranties or guarantees, express or implied, regarding the products or services described herein or their use or applicability. All sales are governed by our terms and conditions, which are available on request. We reserve the right to modify or improve the designs or specifications of our products at any time without notice.

