



Failure Modes, Effects and Diagnostic Analysis

Project:
Rosemount™ 3408 Level Transmitter

Company:
Rosemount Tank Radar AB
Gothenburg
SE

Contract Number: Q21/06-064
Report No.: ROS 21/06-064 R001
Version V1, Revision R2, May 31, 2022
Rudolf Chalupa



Management Summary

This report summarizes the results of the hardware assessment in the form of a Failure Modes, Effects, and Diagnostic Analysis (FMEDA) of the Rosemount™ 3408 Level Transmitter, hardware and software revision per section 2.5.1 A Failure Modes, Effects, and Diagnostic Analysis is one of the steps to be taken to achieve functional safety certification per IEC 61508 of a device. From the FMEDA, failure rates are determined. The FMEDA that is described in this report concerns only the hardware of the 3408. For full functional safety certification purposes, all requirements of IEC 61508 must be considered.

The Rosemount™ 3408 Level Transmitter provides the following safety functions;

- Measure the distance from the micro-wave unit to a liquid or solid surface in a tank. This function is based on a measurement of the delay time between a transmitted micro-wave and the received echo. A FMCW radar sweep is used for this measurement.
- Optionally derive other measurement variables (for example volume) from the measured distance.
- Calculate and emit a 4-20 mA current based on the selected measurement variable

The 3408 is classified as a Type B¹ element according to IEC 61508, having a hardware fault tolerance of 0.

The analysis shows that the 3408 has a Safe Failure Fraction between 90% and 99% (assuming that the logic solver is programmed to detect over-scale and under-scale currents) and therefore meets hardware architectural constraints for up to SIL 2 as a single device.

Based on the assumptions listed in 4.3, the failure rates for the 3408 are listed in section 4.4.

These failure rates are valid for the useful lifetime of the product, see Appendix A.

The failure rates listed in this report are based on over 400 billion unit operating hours of process industry field failure data. The failure rate predictions reflect realistic failures and include site specific failures due to human events for the specified Site Safety Index (SSI), see section 4.2.2.

A user of the 3408 can utilize these failure rates in a probabilistic model of a safety instrumented function (SIF) to determine suitability in part for safety instrumented system (SIS) usage in a particular safety integrity level (SIL).

¹ Type B element: "Complex" element (using micro controllers or programmable logic); for details see 7.4.4.1.3 of IEC 61508-2, ed2, 2010.



Table of Contents

1	Purpose and Scope	4
2	Project Management	5
2.1	<i>exida</i>	5
2.2	Roles of the parties involved	5
2.3	Standards and literature used	5
2.4	<i>exida</i> tools used	6
2.5	Reference documents	6
2.5.1	Documentation provided by Rosemount Tank Radar AB	6
2.5.2	Documentation generated by Rosemount Tank Radar AB and <i>exida</i>	7
3	Product Description	8
4	Failure Modes, Effects, and Diagnostic Analysis	9
4.1	Failure categories description	9
4.2	Methodology – FMEDA, failure rates	10
4.2.1	FMEDA	10
4.2.2	Failure rates	10
4.3	Assumptions	11
4.4	Results	11
5	Using the FMEDA Results	14
5.1	PFD _{avg} calculation 3408	14
5.2	<i>exida</i> Route 2 _H Criteria	14
6	Terms and Definitions	16
7	Status of the Document	17
7.1	Liability	17
7.2	Version History	18
7.3	Future enhancements	18
7.4	Release signatures	18
Appendix A	Lifetime of Critical Components	19
Appendix B	Proof Tests to Reveal Dangerous Undetected Faults	20
B.1	Suggested Proof Tests	20
Appendix C	<i>exida</i> Environmental Profiles	25
Appendix D	Determining Safety Integrity Level	26
Appendix E	Site Safety Index	30
E.1	Site Safety Index Profiles	30
E.2	Site Safety Index Failure Rates – 3408	31



1 Purpose and Scope

This document shall describe the results of the hardware assessment in the form of the Failure Modes, Effects and Diagnostic Analysis carried out on the 3408. From this, failure rates for each failure mode/category, useful life, and proof test coverage are determined.

The information in this report can be used to evaluate whether an element meets the average Probability of Failure on Demand (PFD_{AVG}) requirements and if applicable, the architectural constraints / minimum hardware fault tolerance requirements per IEC 61508 / IEC 61511.

A FMEDA is part of the effort needed to achieve full certification per IEC 61508 or other relevant functional safety standard.



2 Project Management

2.1 *exida*

exida is one of the world’s leading accredited Certification Bodies and knowledge companies specializing in automation system safety, availability, and cybersecurity with over 500 person years of cumulative experience in functional safety, alarm management, and cybersecurity. Founded by several of the world’s top reliability and safety experts from manufacturers, operators and assessment organizations, *exida* is a global corporation with offices around the world. *exida* offers training, coaching, project oriented consulting services, safety engineering tools, detailed product assurance and ANSI accredited functional safety and cybersecurity certification. *exida* maintains a comprehensive failure rate and failure mode database on electronic and mechanical equipment and a comprehensive database on solutions to meet safety standards such as IEC 61508.

2.2 Roles of the parties involved

Rosemount Tank Radar AB Manufacturer of the 3408

exida Reviewed the hardware assessment

Rosemount Tank Radar AB contracted *exida* in June 2021 with the hardware assessment of the above-mentioned device.

2.3 Standards and literature used

The services delivered by *exida* were performed based on the following standards / literature.

[N1]	IEC 61508-2: ed2, 2010	Functional Safety of Electrical/Electronic/Programmable Electronic Safety-Related Systems
[N2]	Electrical Component Reliability Handbook, 4th Edition, 2017	<i>exida</i> LLC, Electrical Component Reliability Handbook, Fourth Edition, 2017
[N3]	Mechanical Component Reliability Handbook, 4th Edition, 2017	<i>exida</i> LLC, Electrical & Mechanical Component Reliability Handbook, Fourth Edition, 2017
[N4]	Goble, W.M. 2010	Control Systems Safety Evaluation and Reliability, 3 rd edition, ISA, ISBN 97B-1-934394-80-9. Reference on FMEDA methods
[N5]	IEC 60654-1:1993-02, second edition	Industrial-process measurement and control equipment – Operating conditions – Part 1: Climatic condition
[N6]	O’Brien, C., Stewart, L. & Bredemeyer, L., 2018	<i>exida</i> LLC., Final Elements in Safety Instrumented Systems, IEC61511 Compliant Systems and IEC 61508 Compliant Products, 2018, ISBN 978-1-9934977-18-7



[N7]	Scaling the Three Barriers, Recorded Web Seminar, June 2013,	Scaling the Three Barriers, Recorded Web Seminar, June 2013, http://www.exida.com/Webinars/Recordings/SIF-Verification-Scaling-the-Three-Barriers
[N8]	Meeting Architecture Constraints in SIF Design, Recorded Web Seminar, March 2013	http://www.exida.com/Webinars/Recordings/Meeting-Architecture-Constraints-in-SIF-Design
[N9]	Random versus Systematic – Issues and Solutions, September 2016	Goble, W.M., Bukowski, J.V., and Stewart, L.L., Random versus Systematic – Issues and Solutions, exida White Paper, PA: Sellersville, www.exida.com/resources/whitepapers , September 2016.
[N10]	Assessing Safety Culture via the Site Safety Index™, April 2016	Bukowski, J.V. and Chastain-Knight, D., Assessing Safety Culture via the Site Safety Index™, Proceedings of the AIChE 12th Global Congress on Process Safety, GCPS2016, TX: Houston, April 2016.
[N11]	Quantifying the Impacts of Human Factors on Functional Safety, April 2016	Bukowski, J.V. and Stewart, L.L., Quantifying the Impacts of Human Factors on Functional Safety, Proceedings of the 12th Global Congress on Process Safety, AIChE 2016 Spring Meeting, NY: New York, April 2016.
[N12]	Criteria for the Application of IEC 61508:2010 Route 2H, December 2016	Criteria for the Application of IEC 61508:2010 Route 2H, exida White Paper, PA: Sellersville, www.exida.com , December 2016.
[N13]	Using a Failure Modes, Effects and Diagnostic Analysis (FMEDA) to Measure Diagnostic Coverage in Programmable Electronic Systems, November 1999	Goble, W.M. and Brombacher, A.C., Using a Failure Modes, Effects and Diagnostic Analysis (FMEDA) to Measure Diagnostic Coverage in Programmable Electronic Systems, Reliability Engineering and System Safety, Vol. 66, No. 2, November 1999.
[N14]	FMEDA – Accurate Product Failure Metrics, June 2015	Grebe, J. and Goble W.M., FMEDA – Accurate Product Failure Metrics, www.exida.com , June 2015.

2.4 *exida* tools used

[T1]	V2.1.0.30307	<i>exida</i> FMEDAx Tool
------	--------------	--------------------------

2.5 Reference documents

2.5.1 Documentation provided by Rosemount Tank Radar AB

[D1]	Doc D7000005-887 Rev P10	Schematic Drawing, CMH
[D2]	Doc # D7000006-939, Rev_P5	Schematic Drawing, PMW



[D3]	Doc # 03031-3511, Rev 24, 2021-09-22	Schematic Drawing, LCD & BLE
[D4]	Doc # DE-0022, Rev 0.9, 2022-02-21	FMEDA Coordination Document (Diagnostics descriptions)
[D5]	Blackbird-RE-0038_Iss 1.5.xlsx, 2022-05-18	FMEDA
[D6]	3408_SafetyManual_00809 -0200- 4418_RevAA_PREL_22051 8.pdf	Preliminary Safety Manual with proof test steps

2.5.2 Documentation generated by Rosemount Tank Radar AB and *exida*

[R1]	Blackbird-RE-0038 Iss 1.4.xlsx	Failure Modes, Effects, and Diagnostic Analysis – 3408
------	-----------------------------------	--

3 Product Description

The Rosemount™ 3408 Level Transmitter level transmitter provides the following safety functions;

- Measuring the distance to a liquid or surface in a tank using the FMCW principle.
- Only ullage and distance are supported as primary variables for SIS.
- Calculate and emit a 4-20 mA current based on the selected measurement variable

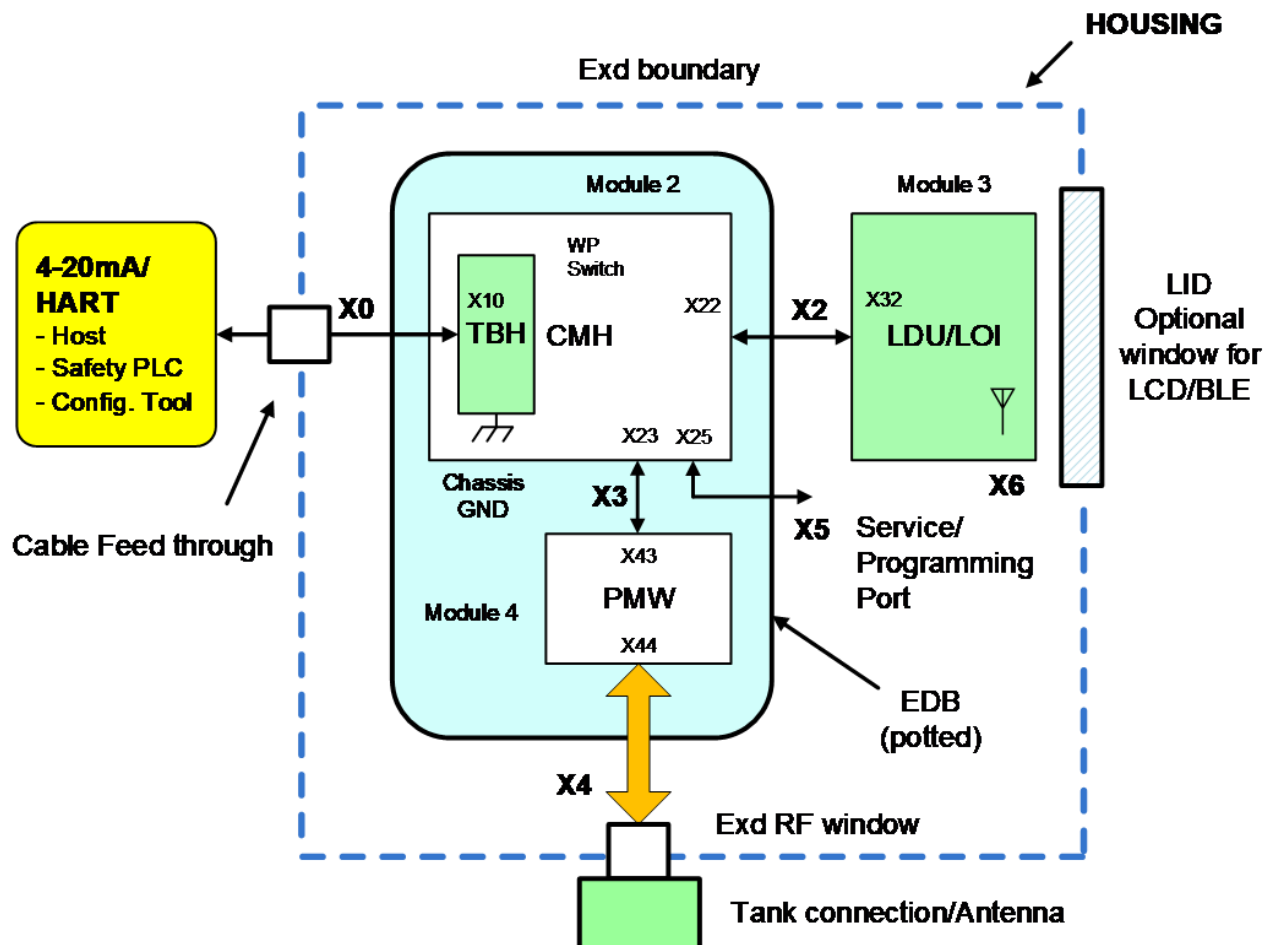

Figure 1 3408, Parts included in the FMEDA

The 3408 is classified as a Type B² element according to IEC 61508, having a hardware fault tolerance of 0.

² Type B element: “Complex” element (using micro controllers or programmable logic); for details see 7.4.4.1.3 of IEC 61508-2, ed2, 2010.



4 Failure Modes, Effects, and Diagnostic Analysis

The Failure Modes, Effects, and Diagnostic Analysis was performed based on the documentation in section 2.5.1 and is documented in [R1].

There are two standard current output ranges for the failsafe output which are user selectable:

- Rosemount standard: < 3.75 or >21.75
- NE-43 standard: < 3.6 mA or > 21 mA

4.1 Failure categories description

In order to judge the failure behavior of the 3408, the following definitions for the failure of the device were considered.

Fail-Safe State	Failure that deviates the process signal or the actual output by more than 2% of span, drifts toward the user defined threshold (Trip Point) and that leaves the output within the active scale.
Fail Safe	Failure that causes the device to go to the defined fail-safe state without a demand from the process.
Fail Detected	Failure that causes the output signal to go to the predefined (user selected) alarm state (RMT or NE 43).
Fail Dangerous	Failure that deviates the process signal or the actual output by more than 2% of span, drifts away from the user defined threshold (Trip Point) and that leaves the output within the active scale.
Fail Dangerous Undetected	Failure that is dangerous and that is not being diagnosed by automatic diagnostics.
Fail Dangerous Detected	Failure that is dangerous but is detected by automatic diagnostics.
Fail High	Failure that causes the output signal to go to the over-range or high alarm output current (> 21.75 mA).
Fail Low	Failure that causes the output signal to go to the under-range or low alarm output current (< 3.6 mA).
No Effect	Failure of a component that is part of the safety function but that has no effect on the safety function.
Annunciation Detected	Failure that does not directly impact safety but does impact the ability to detect a future fault (such as a fault in a diagnostic circuit) and that is detected by internal diagnostics. A Fail Annunciation Detected failure leads to a false diagnostic alarm.
Annunciation Undetected	Failure that does not directly impact safety but does impact the ability to detect a future fault (such as a fault in a diagnostic circuit) and that is not detected by internal diagnostics.

The failure categories listed above expand on the categories listed in IEC 61508 in order to provide a complete set of data needed for design optimization.



Depending on the application, a Fail High or a Fail Low failure can either be safe or dangerous and may be detected or undetected depending on the programming of the logic solver. Consequently, during a Safety Integrity Level (SIL) verification assessment the Fail High and Fail Low failure categories need to be classified as safe or dangerous, detected or undetected.

The Annunciation failures are provided for those who wish to do reliability modeling more detailed than required by IEC61508. It is assumed that the probability model will correctly account for the Annunciation failures.

4.2 Methodology – FMEDA, failure rates

4.2.1 FMEDA

A FMEDA (Failure Mode Effect and Diagnostic Analysis) is a failure rate prediction technique based on a study of design strength versus operational profile stress. It combines design FMEA techniques with extensions to identify automatic diagnostic techniques and the failure modes relevant to safety instrumented system design. It is a technique recommended to generate failure rates for each failure mode category [N13, N14].

4.2.2 Failure rates

The accuracy of any FMEDA analysis depends upon the component reliability data as input to the process. Component data from consumer, transportation, military or telephone applications could generate failure rate data unsuitable for the process industries. The component data used by *exida* in this FMEDA is from the Electrical and Mechanical Component Reliability Handbooks [N3] which were derived using over 400 billion unit operational hours of process industry field failure data from multiple sources and failure data formulas from international standards. The component failure rates are provided for each applicable operational profile and application, see Appendix C. The *exida* profile chosen for this FMEDA was 2 as this was judged to be the best fit for the product and application information submitted by Rosemount Tank Radar AB. It is expected that the actual number of field failures will be less than the number predicted by these failure rates.

Early life failures (infant mortality) are not included in the failure rate prediction as it is assumed that some level of commission testing is done. End of life failures are not included in the failure rate prediction as useful life is specified.

The failure rates are predicted for a Site Safety Index of SSI=2 [N10, N11] as this level of operation is common in the process industries. Failure rate predictions for other SSI levels are included in the exSILentia® tool from exida.

The user of these numbers is responsible for determining the failure rate applicability to any particular environment. *exida* Environmental Profiles listing expected stress levels can be found in Appendix C. Some industrial plant sites have high levels of stress. Under those conditions the failure rate data is adjusted to a higher value to account for the specific conditions of the plant. *exida* has detailed models available to make customized failure rate predictions. Contact *exida*.

Accurate plant specific data may be used to check validity of this failure rate data. If a user has data collected from a good proof test reporting system such as *exida* SILStat™ that indicates higher failure rates, the higher numbers shall be used.



4.3 Assumptions

The following assumptions have been made during the Failure Modes, Effects, and Diagnostic Analysis of the 3408.

- The worst-case assumption of a series system is made. Therefore, only a single component failure will fail the entire 3408 and propagation of failures is not relevant.
- Failure rates are constant for the useful life period.
- Any product component that cannot influence the safety function (feedback immune) is excluded. All components that are part of the safety function including those needed for normal operation are included in the analysis.
- The stress levels are specified in the *exida* Profile used for the analysis are limited by the manufacturer's published ratings.
- Practical fault insertion tests have been used when applicable to demonstrate the correctness of the FMEDA results.
- The HART protocol is only used for setup, calibration, and diagnostics purposes, not for safety critical operation. Neither the Display nor the Bluetooth communications are used for safety critical operation.
- The application program in the logic solver is constructed in such a way that Fail High and Fail Low failures are detected regardless of the effect, safe or dangerous, on the safety function.
- Materials are compatible with process conditions.
- The device is installed and operated per manufacturer's instructions.
- Soft Error Rates (SER) were considered for relative neutron flux of 4.5 corresponding to 1,600 meters above sea level.
- External power supply failure rates are not included.
- Worst-case internal fault detection time is 90 minutes.

4.4 Results

Using reliability data extracted from the *exida* Electrical and Mechanical Component Reliability Handbook the following failure rates resulted from the 3408 FMEDA.

Table 1 lists the failure rates for the 3408 with a Site Safety Index (SSI) of 2 (good site maintenance practices). See Appendix E for an explanation of SSI and the failure rates for SSI of 4 (ideal maintenance practices).



Table 1 Failure rates with Good Maintenance Assumptions in FIT @ SSI=2 (3408)

Failure Category	Failure Rate (FIT)
Fail Safe Undetected	0
Fail Dangerous Detected	699
Fail Detected (detected by internal diagnostics)	605
Fail High (detected by logic solver)	27
Fail Low (detected by logic solver)	67
Fail Dangerous Undetected	39
No Effect	4432
Annunciation Undetected	1

Table 2 lists the failure rates for the 3408 according to IEC 61508.

Table 2 Failure rates with Good Maintenance Assumptions in FIT @ SSI=2 according to IEC 61508

Application/Device/Configuration	λ_{SD}	λ_{SU}^3	λ_{DD}	λ_{DU}	#	SFF
3408	0	0	699	39	4433	94.7%

Where:

λ_{SD} = Fail Safe Detected

λ_{SU} = Fail Safe Undetected

λ_{DD} = Fail Dangerous Detected

λ_{DU} = Fail Dangerous Undetected

= No Effect Failures

These failure rates are valid for the useful lifetime of the product, see Appendix A.

According to IEC 61508-2 the architectural constraints of an element must be determined. This can be done by following the 1_H approach according to 7.4.4.2 of IEC 61508-2 or the 2_H approach according to 7.4.4.3 of IEC 61508-2, or the approach according to IEC 61511:2016 which is based on 2_H (see Section 5.2).

The 1_H approach involves calculating the Safe Failure Fraction for the entire element.

The 2_H approach involves assessment of the reliability data for the entire element according to 7.4.4.3.3 of IEC 61508-2.

³ It is important to realize that the No Effect failures are no longer included in the Safe Undetected failure category according to IEC 61508, ed2, 2010.



The analysis shows that the 3408 has a Safe Failure Fraction between 90% and 99% (assuming that the logic solver is programmed to detect over-scale and under-scale currents) and therefore meets hardware architectural constraints for up to SIL 2 as a single device.

The architectural constraint type for the 3408 is B. The hardware fault tolerance of the device is 0. The SIS designer is responsible for meeting other requirements of applicable standards for any given SIL.

Table 12 lists the failure rates for the 3408 according to IEC 61508 with a Site Safety Index (SSI) of 4 (perfect site maintenance practices). This data should not be used for SIL verification and is provided only for comparison with other analysis than has assumed perfect maintenance. See Appendix E for an explanation of SSI.



5 Using the FMEDA Results

The following section(s) describe how to apply the results of the FMEDA.

5.1 PFD_{avg} calculation 3408

Using the failure rate data displayed in section 4.4, and the failure rate data for the associated element devices, an average the Probability of Failure on Demand (PFD_{avg}) calculation can be performed for the element.

Probability of Failure on Demand (PFD_{avg}) calculation uses several parameters, many of which are determined by the particular application and the operational policies of each site. Some parameters are product specific and the responsibility of the manufacturer. Those manufacturer specific parameters are given in this third-party report.

Probability of Failure on Demand (PFD_{avg}) calculation is the responsibility of the owner/operator of a process and is often delegated to the SIF designer. Product manufacturers can only provide a PFD_{avg} by making many assumptions about the application and operational policies of a site. Therefore, use of these numbers requires complete knowledge of the assumptions and a match with the actual application and site.

Probability of Failure on Demand (PFD_{avg}) calculation is best accomplished with *exida's* exSILentia tool. See Appendix D for a complete description of how to determine the Safety Integrity Level for an element. The mission time used for the calculation depends on the PFD_{avg} target and the useful life of the product. The failure rates and the proof test coverage for the element are required to perform the PFD_{avg} calculation. The proof test coverage for the suggested proof test are listed in Appendix B.

5.2 *exida* Route 2_H Criteria

IEC 61508, ed2, 2010 describes the Route 2_H alternative to Route 1_H architectural constraints. The standard states:

"based on data collected in accordance with published standards (e.g., IEC 60300-3-2: or ISO 14224); and, be evaluated according to

- the amount of field feedback; and
- the exercise of **expert judgment**; and when needed
- the undertaking of specific tests,

in order to estimate the average and the uncertainty level (e.g., the 90% confidence interval or the probability distribution) of each reliability parameter (e.g., failure rate) used in the calculations."

exida has interpreted this to mean not just a simple 90% confidence level in the uncertainty analysis, but a high confidence level in the entire data collection process. As IEC 61508, ed2, 2010 does not give detailed criteria for Route 2_H, *exida* has established the following:

1. field unit operational hours of 100,000,000 per each component; and
2. a device and all its components have been installed in the field for one year or more; and
3. operational hours are counted only when the data collection process has been audited for correctness and completeness; and
4. failure definitions, especially "random" vs. "systematic" [N9] are checked by *exida*; and



5. every component used in an FMEDA meets the above criteria.

This set of requirements is chosen to assure high integrity failure data suitable for safety integrity verification [N12].



6 Terms and Definitions

Automatic Diagnostics	Tests performed online internally by the device or, if specified, externally by another device without manual intervention.
DC	Diagnostic Coverage
<i>exida</i> criteria	A conservative approach to arriving at failure rates suitable for use in hardware evaluations utilizing the 2 _H Route in IEC 61508-2.
Fault tolerance	Ability of a functional unit to continue to perform a required function in the presence of faults or errors (IEC 61508-4, 3.6.3).
FIT	Failure in Time (1×10^{-9} failures per hour)
FMEDA	Failure Mode Effect and Diagnostic Analysis
HFT	Hardware Fault Tolerance
PFD _{avg}	Average Probability of Failure on Demand
SFF	Safe Failure Fraction, summarizes the fraction of failures which lead to a safe state plus the fraction of failures which will be detected by automatic diagnostic measures and lead to a defined safety action.
SIF	Safety Instrumented Function
SIL	Safety Integrity Level
SIS	Safety Instrumented System – Implementation of one or more Safety Instrumented Functions. A SIS is composed of any combination of sensor(s), logic solver(s), and final element(s).
Type A element	“Non-Complex” element (using discrete components); for details see 7.4.4.1.2 of IEC 61508-2
Type B element	“Complex” element (using complex components such as micro controllers or programmable logic); for details see 7.4.4.1.3 of IEC 61508-2



7 Status of the Document

7.1 Liability

exida prepares FMEDA reports based on methods advocated in International standards. Failure rates are obtained from a collection of industrial databases. *exida* accepts no liability whatsoever for the use of these numbers or for the correctness of the standards on which the general calculation methods are based.

Due to future potential changes in the standards, product design changes, best available information and best practices, the current FMEDA results presented in this report may not be fully consistent with results that would be presented for the identical model number product at some future time. As a leader in the functional safety market place, *exida* is actively involved in evolving best practices prior to official release of updated standards so that our reports effectively anticipate any known changes. In addition, most changes are anticipated to be incremental in nature and results reported within the previous three-year period should be sufficient for current usage without significant question.

Most products also tend to undergo incremental changes over time. If an *exida* FMEDA has not been updated within the last three years, contact the product vendor to verify the current validity of the results.



7.2 Version History

Contract Number	Report Number	Revision Notes
Q21/06-064	ROS 21/06-064 R001 V0, R1	Initial draft
Q21/06-064	ROS 21/06-064 R001 V0, R2	Updated product name, added proof tests
Q21/06-064	ROS 21/06-064 R001 V0, R3	Updated per client feedback, 2022-04-26
Q21/06-064	ROS 21/06-064 R001 V1, R1	Updated after internal review, 2022-04-27
Q21/06-064	ROS 21/06-064 R001 V1, R2	Updated per client feedback, 2022-05-31, RPC

Reviewer: John Yozallinas, 31-May-2022

Status: Released, 2022-05-31

7.3 Future enhancements

At request of client.

7.4 Release signatures

Rudolf P. Chalupa, CFSE, Senior Safety Engineer

John Yozallinas, CFSE, Senior Safety Engineer



Appendix A Lifetime of Critical Components

According to section 7.4.9.5 of IEC 61508-2, a useful lifetime, based on experience, should be determined and used to replace equipment before the end of useful life.

Although a constant failure rate is assumed by the exida FMEDA prediction method (see section 4.2.2) this only applies provided that the useful lifetime⁴ of components is not exceeded. Beyond their useful lifetime, the result of the probabilistic calculation method is likely optimistic, as the probability of failure significantly increases with time. The useful lifetime is highly dependent on the subsystem itself and its operating conditions.

Table 3 shows which components are contributing to the dangerous undetected failure rate and therefore to the PFD_{avg} calculation and what their estimated useful lifetime is.

Table 3 Useful lifetime of components contributing to dangerous undetected failure rate

Component	Useful Life
Capacitor (electrolytic) - Tantalum electrolytic, solid electrolyte	Approx. 500,000 hours

It is the responsibility of the end user to maintain and operate the 3408 per manufacturer's instructions. Furthermore, regular inspection should show that all components are clean and free from damage.

The limiting factors with regard to the useful lifetime of the system are the tantalum electrolytic capacitors. Therefore, the useful life is predicted to be 50 years.

When plant experience indicates a shorter useful lifetime than indicated in this appendix, the number based on plant experience should be used.

⁴ Useful lifetime is a reliability engineering term that describes the operational time interval where the failure rate of a device is relatively constant. It is not a term which covers product obsolescence, warranty, or other commercial issues.



Appendix B Proof Tests to Reveal Dangerous Undetected Faults

According to section 7.4.5.2 f) of IEC 61508-2 proof tests shall be undertaken to reveal dangerous faults which are undetected by automatic diagnostic tests. This means that it is necessary to specify how dangerous undetected faults which have been noted during the Failure Modes, Effects, and Diagnostic Analysis can be detected during proof testing.

B.1 Suggested Proof Tests

The following proof tests are suggested:

- Table 5: 1-point level and 2-point analog output verification
- Table 6: 2-point level and 2-point analog output verification
- Table 7: 1-point Analog output verification
- Table 8: 1-point Level and 1-point analog output verification
- Table 9 Suggested Proof Test – Smart echo level test

Table 4 can be used as a guidance for selecting the appropriate proof test.

Table 4 Suggested Proof Tests

Proof test	Type	Proof test coverage (%) of DU	Remaining dangerous, undetected failures	Test coverage			Can be Performed remotely
				Output circuitry	Measurement electronics	Antenna	
Table 5	Comprehensive	74%	10 FIT	Yes	Yes	Yes	Yes
Table 6	Comprehensive	89%	4 FIT	Yes	Yes	Yes	Yes
Table 7	Partial	29%	28 FIT	Yes	No	No	Yes
Table 8	Comprehensive	68%	13 FIT	Yes	Yes	Yes	Yes
Table 9	Partial	32%	23 FIT	Yes	Partial	No	Yes



Table 5 Suggested Proof Test – 1-point level and 2-point analog output verification

Step	Action
1.	Prior to the test, ensure there are no alarms or warnings present in the transmitter. a) Select Service Tools → Alerts.
2.	Bypass the safety function and take appropriate action to avoid a false trip.
3.	Simulate 4.00 mA output and verify loop current. a) Select Service Tools → Simulate. b) Under Analog Out, select Loop test. c) Select 4 mA and then select Next (Start in Rosemount Radar Master Plus). d) Measure loop current (e.g. reading the safety logic solver). e) Verify the current deviation is within the safety deviation of 2% (± 0.32 mA). <i>Note: The inaccuracy of safety logic solver or current meter needs to be considered.</i> f) Select End (Stop in Rosemount Radar Master Plus) to end loop test.
4.	Simulate 20.00 mA output and verify loop current. a) In the Loop test wizard, select 20 mA, and then select Next (Start in Rosemount Radar Master Plus). b) Measure loop current (e.g. reading the safety logic solver). c) Verify the current deviation is within the safety deviation of 2% (± 0.32 mA). <i>Note: The inaccuracy of safety logic solver or current meter needs to be considered.</i> d) Select End (Stop in Rosemount Radar Master Plus) to end loop test.
5.	Perform a one-point level measurement verification of the transmitter in the measuring range. Compare with an independent measurement (e.g. the BPCS level sensor). a) Select Overview and make a note of the current level or distance reading. b) Obtain the level or distance measurement value from an independent level measurement. c) Compare the measurements and verify that the deviation is within the safety deviation of 2%. <i>Note: The inaccuracy of the independent measurement needs to be considered.</i>
6.	Remove the bypass and otherwise restore normal operation.



Table 6 Suggested Proof Test – 2-point level and 2-point analog output verification

Step	Action
1.	<p>Prior to the test, ensure there are no alarms or warnings present in the transmitter.</p> <p>a) Select Service Tools → Alerts.</p>
2.	<p>Bypass the safety function and take appropriate action to avoid a false trip.</p>
3.	<p>Simulate 4.00 mA output and verify loop current.</p> <p>a) Select Service Tools → Simulate.</p> <p>b) Under Analog Out, select Loop test.</p> <p>c) Select 4 mA and then select Next (Start in Rosemount Radar Master Plus).</p> <p>d) Measure loop current (e.g. reading the safety logic solver).</p> <p>e) Verify the current deviation is within the safety deviation of 2% (± 0.32 mA).</p> <p><i>Note: The inaccuracy of safety logic solver or current meter needs to be considered.</i></p> <p>f) Select End (Stop in Rosemount Radar Master Plus) to end loop test.</p>
4.	<p>Simulate 20.00 mA output and verify loop current.</p> <p>a) In the Loop test wizard, select 20 mA, and then select Next (Start in Rosemount Radar Master Plus).</p> <p>b) Measure loop current (e.g. reading the safety logic solver).</p> <p>c) Verify the current deviation is within the safety deviation of 2% (± 0.32 mA).</p> <p><i>Note: The inaccuracy of safety logic solver or current meter needs to be considered.</i></p> <p>d) Select End (Stop in Rosemount Radar Master Plus) to end loop test.</p>
5.	<p>Perform a two-point level measurement verification of the transmitter in the measuring range. Compare with an independent measurement (e.g. the BPCS level sensor).</p> <p>a) Select Overview and make a note of the current level or distance reading.</p> <p>b) Obtain the level or distance measurement value from an independent level measurement.</p> <p>c) Compare the measurements and verify that the deviation is within the safety deviation of 2%.</p> <p><i>Note: The inaccuracy of the independent measurement needs to be considered.</i></p> <p>d) Move the surface in the tank at least 10% of the full measuring span (level 0-100%).</p> <p>e) Repeat steps 5.a-5.c for the second point.</p>
6.	<p>Remove the bypass and otherwise restore normal operation.</p>



Table 7 Suggested Proof Test – 1-point Analog output verification

Step	Action
1.	Obtain the loop current as a digital value. Do one of the following: <ul style="list-style-type: none">• Go to the Overview screen and read the current analog output value.• Read HART command 2 or 3 via the host system. Command 2: Analog output current and Percent of range Command 3: Device variables (PV, SV, TV, and QV) and Analog output current
2.	Obtain the loop current as an analog value (e.g. by using the safety logic solver).
3.	Compare the current values.
4.	Verify the current deviation is within the safety deviation of 2% (± 0.32 mA). <i>Note: The inaccuracy of safety logic solver needs to be considered.</i>

Table 8 Suggested Proof Test – 1-point Level and 1-point analog output verification

Step	Action
1.	Obtain the level (or distance) measurement value derived from the analog output (e.g. by checking measurement value in safety logic solver).
2.	Obtain the level (or distance) measurement value from an independent level measurement (e.g. the BPCS level sensor).
3.	Compare the measurements and verify that the deviation is within the safety deviation of 2%.



Table 9 Suggested Proof Test – Smart echo level test

Step	Action
	Prior to and during the test, ensure that: <ul style="list-style-type: none">• The product surface is calm.• The smart echo level is not closer than 1 ft. (0.3 m) to the liquid surface.• The tank is not being filled or emptied.
1.	Ensure there are no alarms or warnings present in the transmitter. (In Rosemount Radar Master Plus, under Service Tools, select “Alerts”.)
2.	Bypass the process safety function and take appropriate action to avoid a false trip.
3.	Perform the Smart Echo Level test. <ul style="list-style-type: none">a) Under Service Tools, select Proof Test.b) Select Smart Echo Level Test.c) Select Start. The analog output goes to high saturation.d) Measure loop current (e.g. reading the safety logic solver or using the TEST terminal).e) Verify the current deviation is within the safety deviation of 2% (± 0.32 mA). Note: The inaccuracy of safety logic solver or current meter needs to be considered.f) Select Stop to end test mode.
4.	Remove the bypass and otherwise restore normal operation.



Appendix C *exida* Environmental Profiles

Table 10 *exida* Environmental Profiles

<i>exida</i> Profile	1	2	3	4	5	6
Description (Electrical)	Cabinet mounted/ Climate Controlled	Low Power Field Mounted no self-heating	General Field Mounted self-heating	Subsea	Offshore	N/A
Description (Mechanical)	Cabinet mounted/ Climate Controlled	General Field Mounted	General Field Mounted	Subsea	Offshore	Process Wetted
IEC 60654-1 Profile	B2	C3 also applicable for D1	C3 also applicable for D1	N/A	C3 also applicable for D1	N/A
Average Ambient Temperature	30 C	25 C	25 C	5 C	25 C	25 C
Average Internal Temperature	60 C	30 C	45 C	5 C	45 C	Process Fluid Temp.
Daily Temperature Excursion (pk-pk)	5 C	25 C	25 C	0 C	25 C	N/A
Seasonal Temperature Excursion (winter average vs. summer average)	5 C	40 C	40 C	2 C	40 C	N/A
Exposed to Elements / Weather Conditions	No	Yes	Yes	Yes	Yes	Yes
Humidity⁵	0-95% Non-Condensing	0-100% Condensing	0-100% Condensing	0-100% Condensing	0-100% Condensing	N/A
Shock⁶	10 g	15 g	15 g	15 g	15 g	N/A
Vibration⁷	2 g	3 g	3 g	3 g	3 g	N/A
Chemical Corrosion⁸	G2	G3	G3	G3	G3	Compatible Material
Surge⁹						
Line-Line	0.5 kV	0.5 kV	0.5 kV	0.5 kV	0.5 kV	N/A
Line-Ground	1 kV	1 kV	1 kV	1 kV	1 kV	
EMI Susceptibility¹⁰						
80 MHz to 1.4 GHz	10 V/m	10 V/m	10 V/m	10 V/m	10 V/m	N/A
1.4 GHz to 2.0 GHz	3 V/m	3 V/m	3 V/m	3 V/m	3 V/m	
2.0GHz to 2.7 GHz	1 V/m	1 V/m	1 V/m	1 V/m	1 V/m	
ESD (Air)¹¹	6 kV	6 kV	6 kV	6 kV	6 kV	N/A

⁵ Humidity rating per IEC 60068-2-3

⁶ Shock rating per IEC 60068-2-27

⁷ Vibration rating per IEC 60068-2-6

⁸ Chemical Corrosion rating per ISA 71.04

⁹ Surge rating per IEC 61000-4-5

¹⁰ EMI Susceptibility rating per IEC 61000-4-3

¹¹ ESD (Air) rating per IEC 61000-4-2



Appendix D Determining Safety Integrity Level

The information in this appendix is intended to provide the method of determining the Safety Integrity Level (SIL) of a Safety Instrumented Function (SIF). **The numbers used in the examples are not for the product described in this report.**

Three things must be checked when verifying that a given Safety Instrumented Function (SIF) design meets a Safety Integrity Level (SIL) [N4] and [N7].

These are:

- A. Systematic Capability or Prior Use Justification for each device meets the SIL level of the SIF;
- B. Architecture Constraints (minimum redundancy requirements) are met; and
- C. a PFD_{avg} calculation result is within the range of numbers given for the SIL level.

A. Systematic Capability (SC) is defined in IEC61508:2010. The SC rating is a measure of design quality based upon the methods and techniques used to design and development a product. All devices in a SIF must have a SC rating equal or greater than the SIL level of the SIF. For example, a SIF is designed to meet SIL 3 with three pressure transmitters in a 2oo3 voting scheme. The transmitters have an SC2 rating. The design does not meet SIL 3. Alternatively, IEC 61511 allows the end user to perform a "Prior Use" justification. The end user evaluates the equipment to a given SIL level, documents the evaluation and takes responsibility for the justification.

B. Architecture constraints require certain minimum levels of redundancy. Different tables show different levels of redundancy for each SIL level. A table is chosen and redundancy is incorporated into the design [N8].

C. Probability of Failure on Demand (PFD_{avg}) calculation uses several parameters, many of which are determined by the particular application and the operational policies of each site. Some parameters are product specific and the responsibility of the manufacturer. Those manufacturer specific parameters are given in this third-party report.

A Probability of Failure on Demand (PFD_{avg}) calculation must be done based on a number of variables including:

1. Failure rates of each product in the design including failure modes and any diagnostic coverage from automatic diagnostics (an attribute of the product given by this FMEDA report);
2. Redundancy of devices including common cause failures (an attribute of the SIF design);
3. Proof Test Intervals (assignable by end user practices);
4. Mean Time to Restore (an attribute of end user practices);
5. Proof Test Effectiveness; (an attribute of the proof test method used by the end user with an example given by this report);
6. Mission Time (an attribute of end user practices);
7. Proof Testing with process online or shutdown (an attribute of end user practices);
8. Proof Test Duration (an attribute of end user practices); and
9. Operational/Maintenance Capability (an attribute of end user practices).

The product manufacturer is responsible for the first variable. Most manufacturers use the *exida* FMEDA technique which is based on over 400 billion hours of field failure data in the process industries to predict these failure rates as seen in this report. A system designer chooses the second variable. All other variables are the responsibility of the end user site. The exSILentia® SILVer™ software considers all these variables and provides an effective means to calculate PFD_{avg} for any given set of variables.

Simplified equations often account for only for first three variables. The equations published in IEC 61508-6, Annex B.3.2 [N1] cover only the first four variables. IEC61508-6 is only an informative portion of the standard and as such gives only concepts, examples and guidance based on the idealistic assumptions stated. These assumptions often result in optimistic PFD_{avg} calculations and have indicated SIL levels higher than reality. Therefore, idealistic equations should not be used for actual SIF design verification.

All the variables listed above are important. As an example, consider a high-level protection SIF. The proposed design has a single SIL 3 certified level transmitter, a SIL 3 certified safety logic solver, and a single remote actuated valve consisting of a certified solenoid valve, certified scotch yoke actuator and a certified ball valve. Note that the numbers chosen are only an example and not the product described in this report.

Using exSILentia with the following variables selected to represent results from simplified equations:

- Mission Time = 5 years
- Proof Test Interval = 1 year for the sensor and final element, 5 years for the logic solver
- Proof Test Coverage = 100% (ideal and unrealistic but commonly assumed)
- Proof Test done with process offline

This results in a PFD_{avg} of $6.82E-03$ which meets SIL 2 with a risk reduction factor of 147. The subsystem PFD_{avg} contributions are Sensor $PFD_{avg} = 5.55E-04$, Logic Solver $PFD_{avg} = 9.55E-06$, and Final Element $PFD_{avg} = 6.26E-03$. See Figure 2.

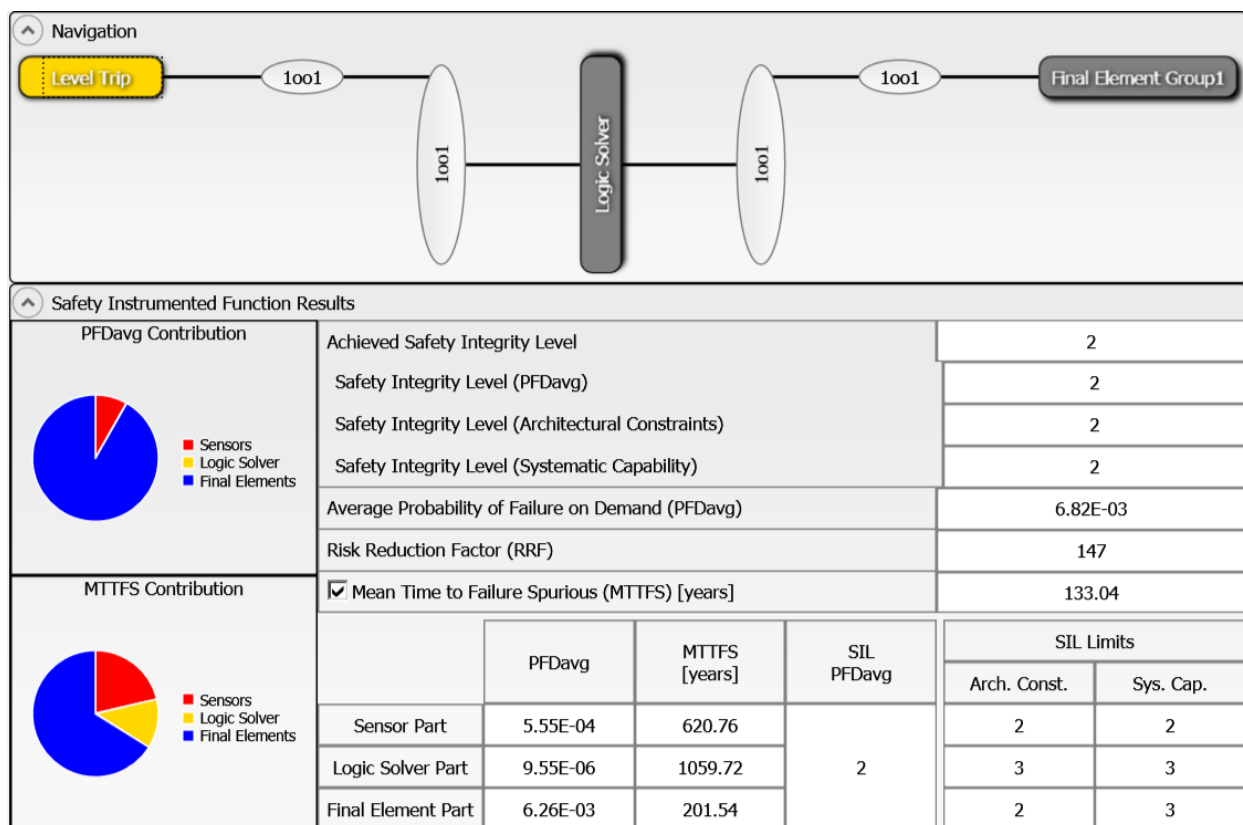

Figure 2: exSILentia results for idealistic variables.

If the Proof Test Interval for the sensor and final element is increased in one year increments, the results are shown in Figure 3.

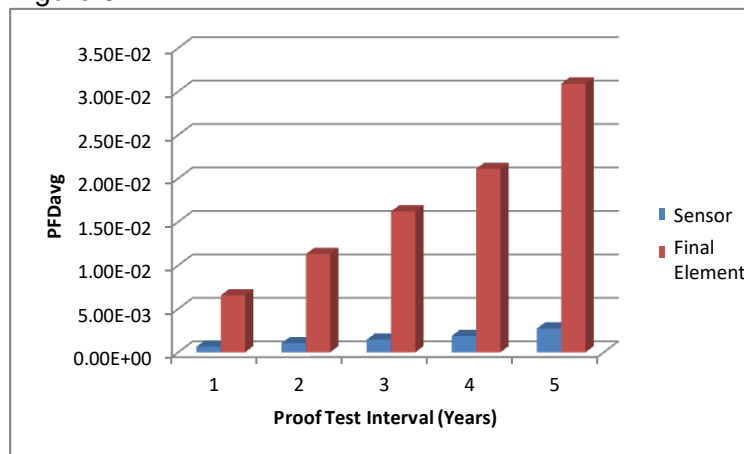

Figure 3 PFD_{avg} versus Proof Test Interval.

If a set of realistic variables for the same SIF are entered into the exSILentia software including:

- Mission Time = 25 years
- Proof Test Interval = 1 year for the sensor and final element, 5 years for the logic solver
- Proof Test Coverage = 90% for the sensor and 70% for the final element
- Proof Test Duration = 2 hours with process online.
- MTTR = 48 hours
- Maintenance Capability = Medium for sensor and final element, Good for logic solver

with all other variables remaining the same, the PFD_{avg} for the SIF equals 5.76E-02 which barely meets SIL 1 with a risk reduction factor 17. The subsystem PFD_{avg} contributions are Sensor PFD_{avg} = 2.77E-03, Logic Solver PFD_{avg} = 1.14E-05, and Final Element PFD_{avg} = 5.49E-02 (Figure 4).

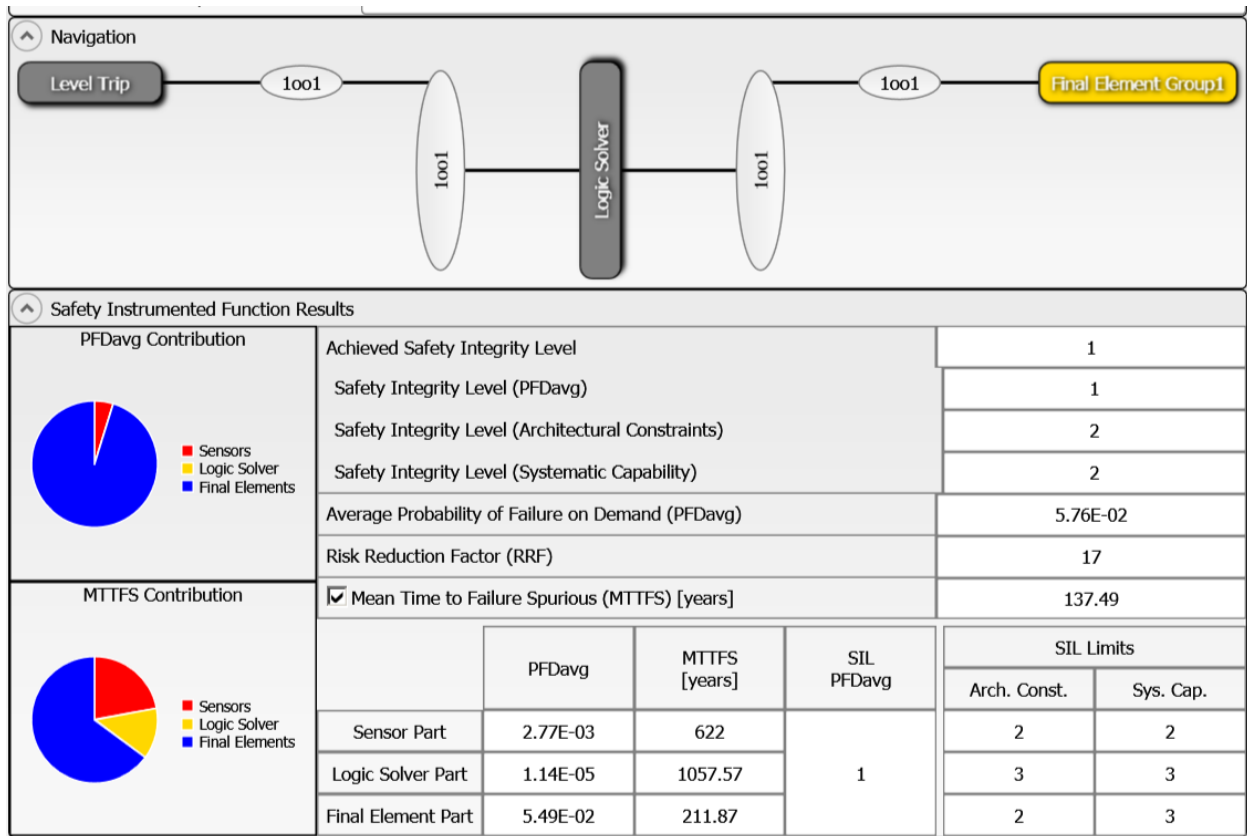

Figure 4: exSILentia results with realistic variables

It is clear that PFD_{avg} results can change an entire SIL level or more when all critical variables are not used.



Appendix E Site Safety Index

Numerous field failure studies have shown that the failure rate for a specific device (same Manufacturer and Model number) will vary from site to site. The Site Safety Index (SSI) was created to account for these failure rates differences as well as other variables. The information in this appendix is intended to provide an overview of the Site Safety Index (SSI) model used by *exida* to compensate for site variables including device failure rates.

E.1 Site Safety Index Profiles

The SSI is a number from 0 – 4 which is an indication of the level of site activities and practices that contribute to the safety performance of SIF's on the site. Table 11 details the interpretation of each SSI level. Note that the levels mirror the levels of SIL assignment and that SSI 4 implies that all requirements of IEC 61508 and IEC 61511 are met at the site and therefore there is no degradation in safety performance due to any end-user activities or practices, i.e., that the product inherent safety performance is achieved.

Several factors have been identified thus far which impact the Site Safety Index (SSI). These include the quality of:

- Commission Test
- Safety Validation Test
- Proof Test Procedures
- Proof Test Documentation
- Failure Diagnostic and Repair Procedures
- Device Useful Life Tracking and Replacement Process
- SIS Modification Procedures
- SIS Decommissioning Procedures
- and others

Table 11 *exida* Site Safety Index Profiles

Level	Description
SSI 4	Perfect - Repairs are always correctly performed, Testing is always done correctly and on schedule, equipment is always replaced before end of useful life, equipment is always selected according to the specified environmental limits and process compatible materials. Electrical power supplies are clean of transients and isolated, pneumatic supplies and hydraulic fluids are always kept clean, etc. Note: This level is generally considered not possible but retained in the model for comparison purposes.
SSI 3	Almost perfect - Repairs are correctly performed, Testing is done correctly and on schedule, equipment is normally selected based on the specified environmental limits and a good analysis of the process chemistry and compatible materials. Electrical power supplies are normally clean of transients and isolated, pneumatic supplies and hydraulic fluids are mostly kept clean, etc. Equipment is replaced before end of useful life, etc.
SSI 2	Good - Repairs are usually correctly performed, Testing is done correctly and mostly on schedule, most equipment is replaced before end of useful life, etc.
SSI 1	Medium – Many repairs are correctly performed, Testing is done and mostly on schedule, some equipment is replaced before end of useful life, etc.
SSI 0	None - Repairs are not always done, Testing is not done, equipment is not replaced until failure, etc.



E.2 Site Safety Index Failure Rates – 3408

Failure rates of each individual device in the SIF are increased or decreased by a specific multiplier which is determined by the SSI value and the device itself. It is known that final elements are more likely to be negatively impacted by less than ideal end-user practices than are sensors or logic solvers. By increasing or decreasing device failure rates on an individual device basis, it is possible to more accurately account for the effects of site practices on safety performance.

Table 12 lists the failure rates for the 3408 according to IEC 61508 with a Site Safety Index (SSI) of 4 (ideal maintenance practices).

Table 12 Failure rates for Static Applications with Ideal Maintenance Assumption in FIT (SSI=4)

Application/Device/Configuration	λ_{SD}	λ_{SU}	λ_{DD}	λ_{DU}	#	SFF
3408	0	0	629	35	3990	94.7%