

FBxRemote I/O™ Quick Start Guide



Application & Device Safety Considerations

▪ **Reading these Instructions**

Before operating a device or application, read these instructions carefully and understand their safety implications. In some situations, improper use may result in damage or injury. Keep this manual in a convenient location for future reference. Note that these instructions may not cover all details or variations in equipment or cover every possible situation regarding installation, operation, or maintenance. Should problems arise that are not covered sufficiently in the text, immediately contact Energy and Transportation Solutions (ETS) Customer Support for further information.

▪ **Protecting Operating Processes**

The failure of a device or application – for whatever reason – may leave an operating process without appropriate protection and could result in possible damage to property or injury to persons. To protect against this, review the need for additional backup equipment or provide alternate means of protection (such as alarm devices, output limiting, fail-safe valves, relief valves, emergency shutoffs, emergency switches, etc.). Contact ETS for additional information.

▪ **Using Qualified Personnel**

Installation, configuration, and any subsequent modifications to a device or application should only be performed by qualified, suitably trained personnel information.

▪ **System Training**

A well-trained workforce is critical to the success of your operation. Knowing how to correctly install, configure, program, calibrate, and troubleshoot your Emerson equipment provides your engineers and technicians with the skills and confidence to optimize your investment. ETS offers a variety of ways for your personnel to acquire essential system expertise. Our full-time professional instructors can conduct classroom training at several of our corporate offices, at your site, or even at your regional Emerson office. You can also receive the same quality training via our live, interactive Emerson Virtual Classroom and save on travel costs. For our complete schedule and further information, contact the ETS Training Department at 800-338-8158 or email us at education@emerson.com.

▪ **Grounding Equipment**

Ground metal enclosures and exposed metal parts of electrical instruments in accordance with relevant safety standards. For the USA, refer to OSHA rules and regulations as specified in *Design Safety Standards for Electrical Systems*, 29 CFR, Part 1910, Subpart S, dated: May 16, 1981 (OSHA rulings are in agreement with the National Electrical Code). For international locations, refer to IEC 60364-4-41: PROTECTION AGAINST ELECTRIC SHOCK. You must also ground mechanical or pneumatic instruments that include electrically operated devices such as lights, switches, relays, alarms, or chart drives. The chassis (or earth ground) lug provides a safe connection point to a customer-designated ground location for ESD and transient voltage suppression. Do not use the chassis ground lug for signal, common, or return connections. **Do not connect the chassis ground lug directly to a lightning arrester/lightning rod.** Do not run signal wiring in conduit or open trays with power wiring or near heavy electrical equipment. If shielded wiring is used, ground the shield of the signal wiring at any one point of the signal loop.

Important: Complying with the codes and regulations of authorities having jurisdiction is essential to ensuring personnel safety. The guidelines and recommendations in this manual are intended to meet or exceed applicable codes and regulations. If differences occur between this manual and the codes and regulations of authorities having jurisdiction, those codes and regulations must take precedence.

▪ **Protecting from Electrostatic Discharge (ESD)**

Any device contains sensitive electronic components which can be damaged by exposure to an ESD voltage. Depending on the magnitude and duration of the ESD, it can result in erratic operation or complete failure of the equipment. Ensure that you correctly care for and handle ESD-sensitive components.

▪ **Ethernet Connectivity**

This automation device is intended to be used in an Ethernet network which **does not** have public access. The inclusion of this device in a publicly accessible Ethernet-based network is **not recommended**.

▪ **Returning Equipment**

If you need to return any equipment to ETS, it is your responsibility to ensure that the equipment has been cleaned to safe levels, as defined and/or determined by applicable federal, state and/or local law regulations or codes. You also agree to indemnify ETS and hold ETS harmless from any liability or damage which ETS may incur or suffer due to your failure to ensure device cleanliness.

Contents

Safety First!	1
Required Tools	2
Mounting on the DIN Rail	2
Grounding the FBxRemote I/O™	3
Removing Battery Saver Tabs	4
Wiring Communications	5
Wiring I/O (3MIX12/3MSG12)	11
Wiring Power	19
Installing Field Tools Configuration Software	20
Establishing a Connection and Configuring Remote I/O	22
Connecting to the FBxRemote I/O	22
Configuring the IP Address and DNP3 Address of the Remote I/O	24
Example - Configuring I/O in the FBxRemote I/O	27
Example - Transferring Data from the FBxRemote I/O to the Host RTU	30
Before You Begin	30
Configuring FBxNet to Transfer Data	32

FBxRemote I/O™ Quick Start Guide

D301902X012

November 2023

Safety First!

Notes

- If the equipment is used in a manner not specified by the manufacturer, the protection provided by the equipment may be impaired.
 - Wiring to or from this device, which either enters or leaves the user-provided enclosure, **must** adhere to wiring methods suitable for Class I, Zone 2 and Division 2 Hazardous locations, as appropriate for the installation.
-



This product may display safety label(s) to identify potential hazards. The same types of notices appear within the documentation. Whenever you see an exclamation point (!) enclosed within a triangle (shown to the left), consult the documentation for additional safety information about the hazard and how to avoid it. The labels used are:

DANGER

MAY CAUSE DEATH

Observe all precautionary signs posted on the equipment.

Failure to do so may result in death or serious injury to personnel.

WARNING

DANGER TO PERSONNEL AND EQUIPMENT

Observed all precautionary signs posted on the equipment.

Failure to do so may result in injury to personnel or cause damage to the equipment.

CAUTION

MAY CAUSE INJURY TO PERSONNEL OR DAMAGE EQUIPMENT

Observed all precautionary signs posted on the equipment.

Failure to do so may result in injury to personnel or cause damage to the equipment.

SAFETY FIRST

General instructions and safety reminders.

Required Tools

Certain tools and equipment are required for installing and servicing the RTU:

Table 1: Required Tools

Tool	Use
#2 Phillips screwdriver	For chassis ground lug, panel installation, removal of rear panel.
¼ "slotted blade screwdriver	For removing personality modules I
Magnets	For removing battery
Non-metallic tool	For removing battery
Laptop PC running Field Tools with FBxConnect configuration software	For software configuration

Mounting on the DIN Rail

The back of RTU chassis includes a removeable mounting plate with a slot for DIN-rail mounting, using either 7.5 or 15 mm DIN rails.

Chassis Mounting

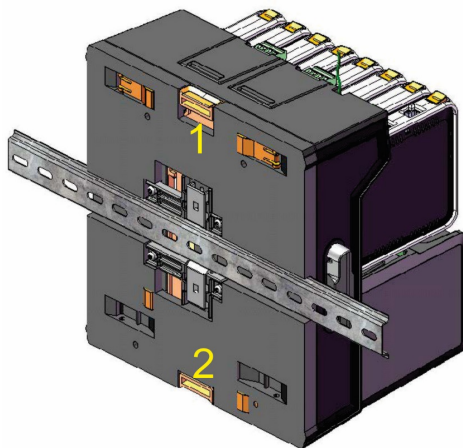

- 1 Upper tab retracts DIN rail clips
 - 2 Lower tab extends DIN rail clips they snap back into place
-

Grounding the FBxRemote I/O™

The FBxRemote I/O rack includes a chassis ground lug to the left of the power supply modules.

Chassis Ground Lug Location (8-slot left, 4-slot right)



-
- Once you have installed the unit, run a ground wire (14 AWG protective conductor) between the ground lug and a known good earth ground.
 - Use stranded copper wire to earth ground and keep the length as short as possible.
 - Clamp or braise the ground wire to the ground bed conductor (typically a stranded copper AWG 0000 cable installed vertically or horizontally).
 - Run the ground wire so that any routing bend in the cable has a minimum radius of 30.48 cm (12 inches) below ground and 20.32 cm (8 inches) above ground.
 - If using one or more extension chassis for additional I/O capacity, ground each chassis individually.

For more information on grounding or if your installation uses cathodic protection, refer to *Site Considerations for Equipment Installation, Grounding, and Wiring* (D301452X012).

Removing Battery Saver Tabs

When you are ready to install the rack and place it into operation, you must remove the battery saver tabs for the SRAM coin cell batteries. Each power module, as well as the CPU, has a similar tab.

Grasp the tab on the "REMOVE BEFORE USE" label and pull the tab straight out.

Battery Saver Tab



Wiring Communications

The communication ports allow you to connect to a PC or laptop running FBxConnect software or to other devices. Regardless of the interface standard [RS-232, RS-485 (4-wire), or RS-485 (2-wire)], you must use FBxConnect to configure the port for proper usage. **Note:** Older standards refer to RS-485 (4-wire) as RS-422.

Serial Ports

COM1 Configured as RS-232

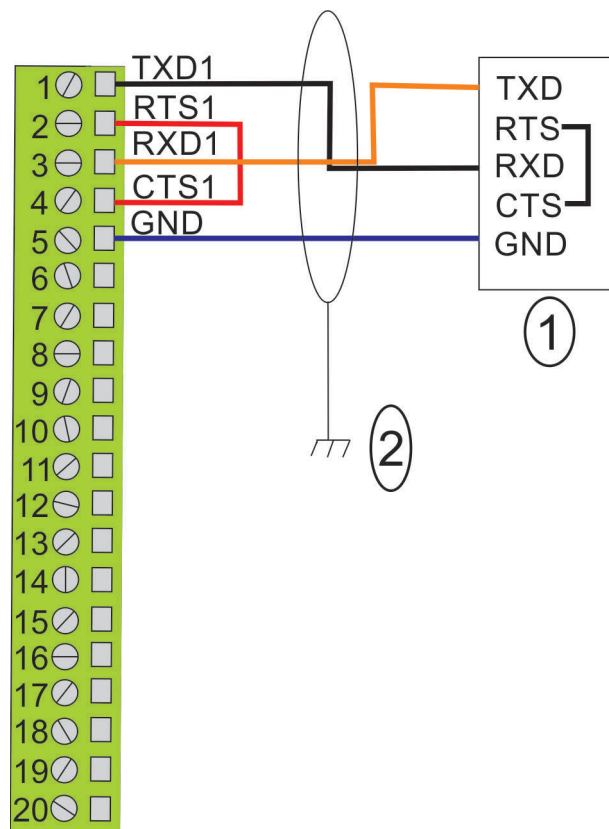

- 1 RS-232 port on device
- 2 Connect cable shields to suitable Instrument Earth connection point

FBxRemote I/O™ Quick Start Guide

D301902X012

November 2023

COM1 Configured as RS-485 (4-wire)

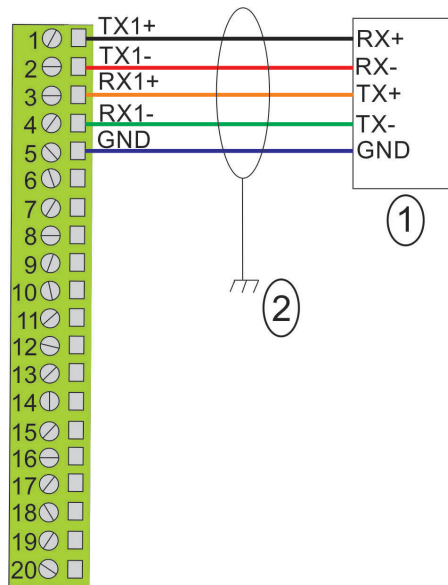

- 1 RS-485 (4-wire) port on device
 - 2 Connect cable shields to suitable Instrument Earth connection point
-

COM1 Configured as RS-485 (2-wire)

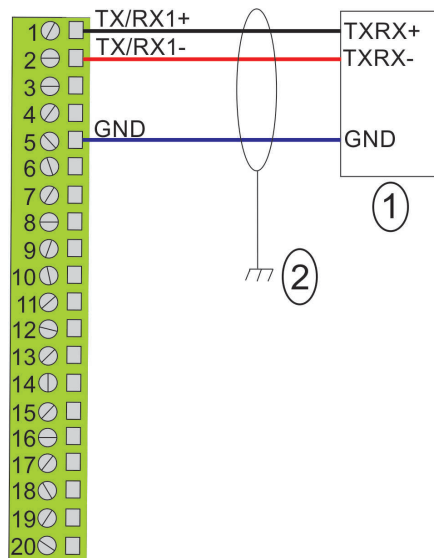

- 1 RS-485 (2-wire) port on device
 - 2 Connect cable shields to suitable Instrument Earth connection point
-

COM2 Configured as RS-232

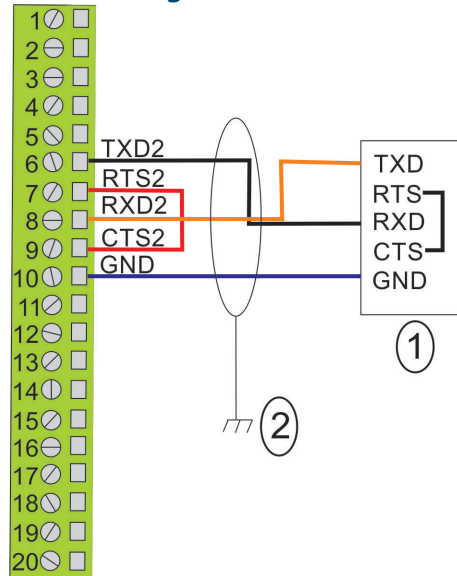

- 1 RS-485 port on device
- 2 Connect cable shields to suitable Instrument Earth connection point

COM2 Configured as RS-485 (4-wire)

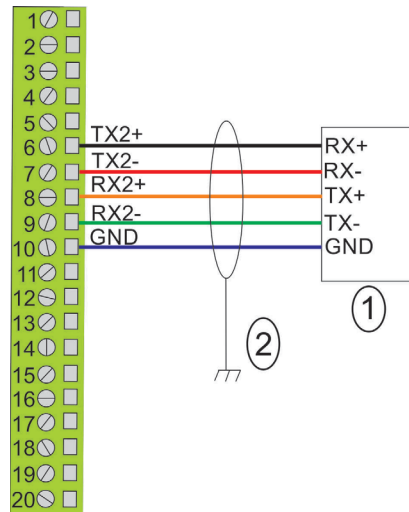

- 1 RS-485 (4-wire) port on device
- 2 Connect cable shields to suitable Instrument Earth connection point

FBxRemote I/O™ Quick Start Guide

D301902X012

November 2023

COM2 Configured as RS-485 (2-wire)

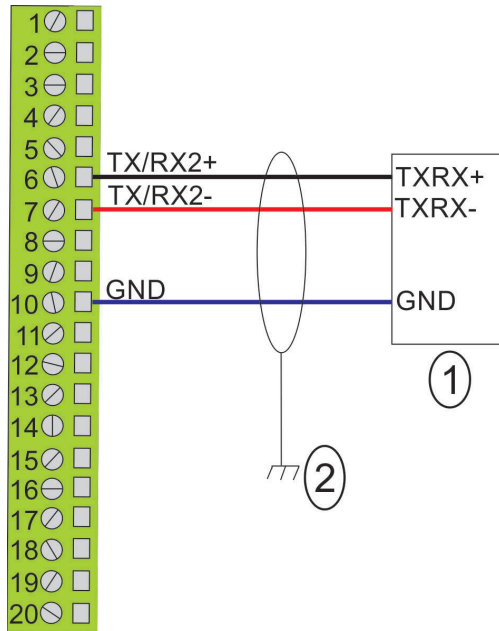

- 1 RS-485 (2-wire) port on device
- 2 Connect cable shields to suitable Instrument Earth connection point

COM3 Configured as RS-485 (2-wire)

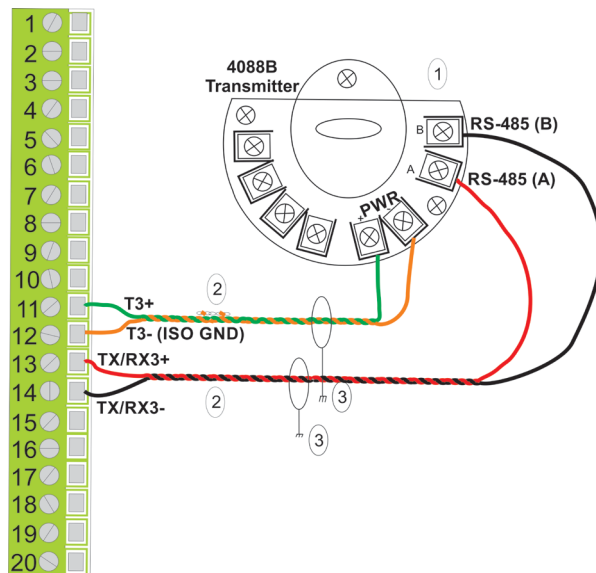

- 1 Enable AC termination using switch
- 2 RS-485 bus, twisted pair required
- 3 Connect cable shields to suitable Instrument Earth connection point

COM4 Configured as RS-485 (2-wire)

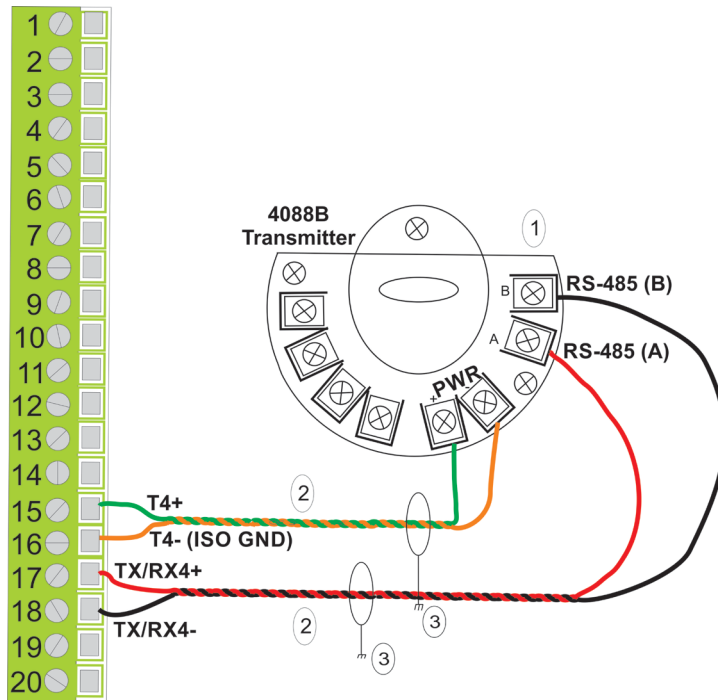

- 1 Enable AC termination using switch
- 2 RS-485 bus, twisted pair required
- 3 Connect cable shields to suitable Instrument Earth connection point

Ethernet and Micro USB Ports

Located on the top of the CPU module, the two Ethernet ports are standard 8-pin 10/100Base-T RJ-45 8P8C sockets. The Micro A-B USB connector is located on the front of the module. The Micro A-B USB connector is compatible with either Micro A USB or Micro B USB plugs, but **is not compatible** with Micro C plugs. You can use the Micro A-B USB port for DNP3 slave communications. When configuring the USB port, ignore baud rate and other settings; simply choose the correct COM port and communicate as if using one of the serial ports.

Location of Ethernet and USB Ports



- 1 Ethernet Port 1
 - 2 Ethernet Port 2
 - 3 Micro A-B USB Port
-

Wiring I/O (3MIX12/3MSG12)

Note:

This section describes wiring for the standard 3MIX12/3MSG12 module. For details on wiring other types of I/O modules; please refer to the *Emerson FB3000 RTU Instruction Manual (D301851X012)*.

You can individually configure AI/DI/PI1 through AI/DI/PI8 as analog inputs (AI), digital inputs (DI), or pulse inputs (PI).

Analog Input (AI)

AI Wiring Using 1-5 Vdc or 4-20 mA

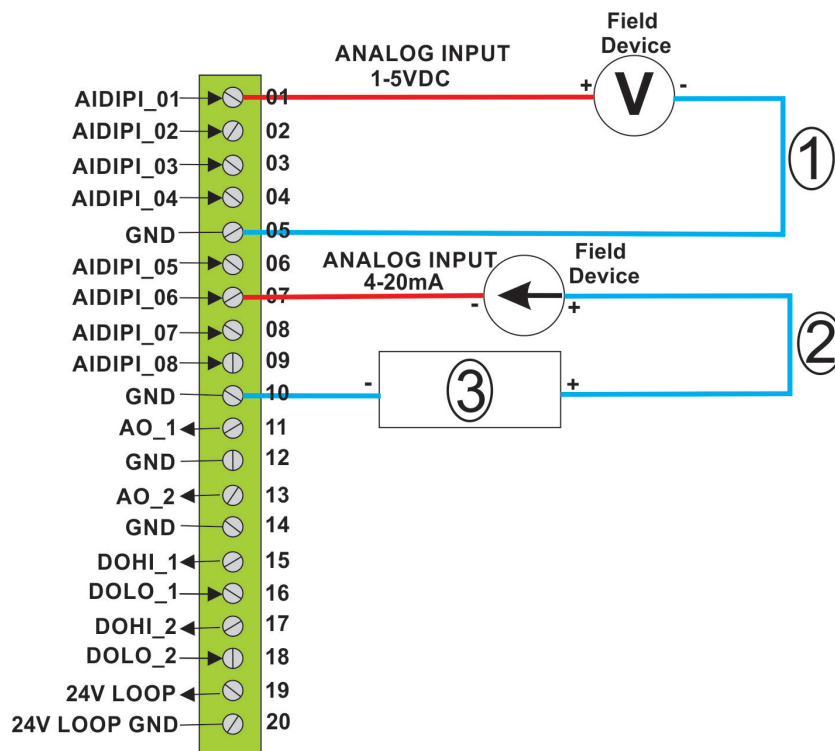

- 1 External Voltage Source
- 2 External Current Source
- 3 Power Supply 30VDC Max

FBxRemote I/O™ Quick Start Guide

D301902X012

November 2023

AI Wiring Using Loop Power

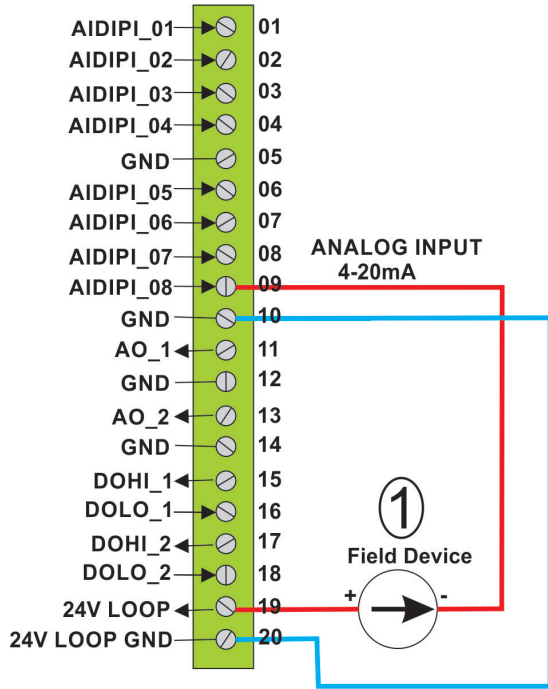

1 External Current Source

Analog Output (AO)

AO Wiring

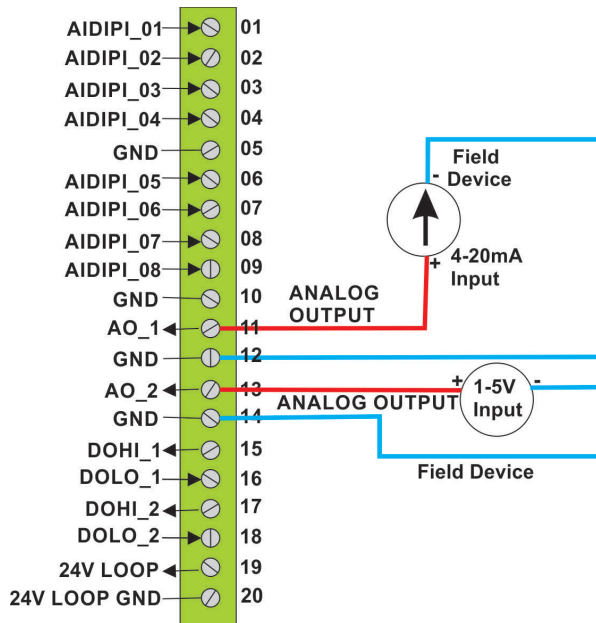

Digital Input (DI)

DI Wiring (internal pull-up enabled)

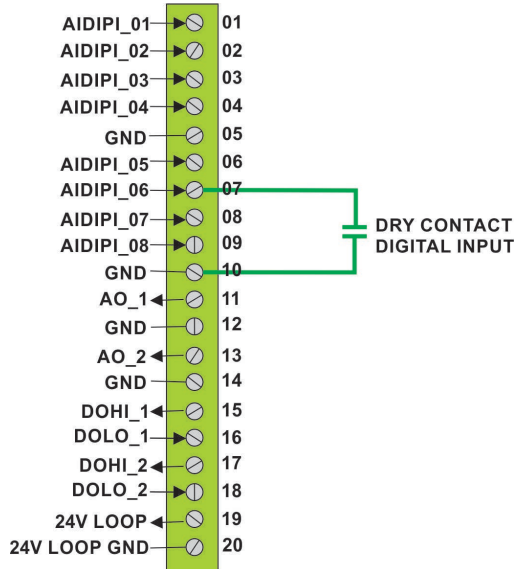

Digital Output (DO)

Digital Output (DO) Wiring - Low Side Switch (LSS) Enabled

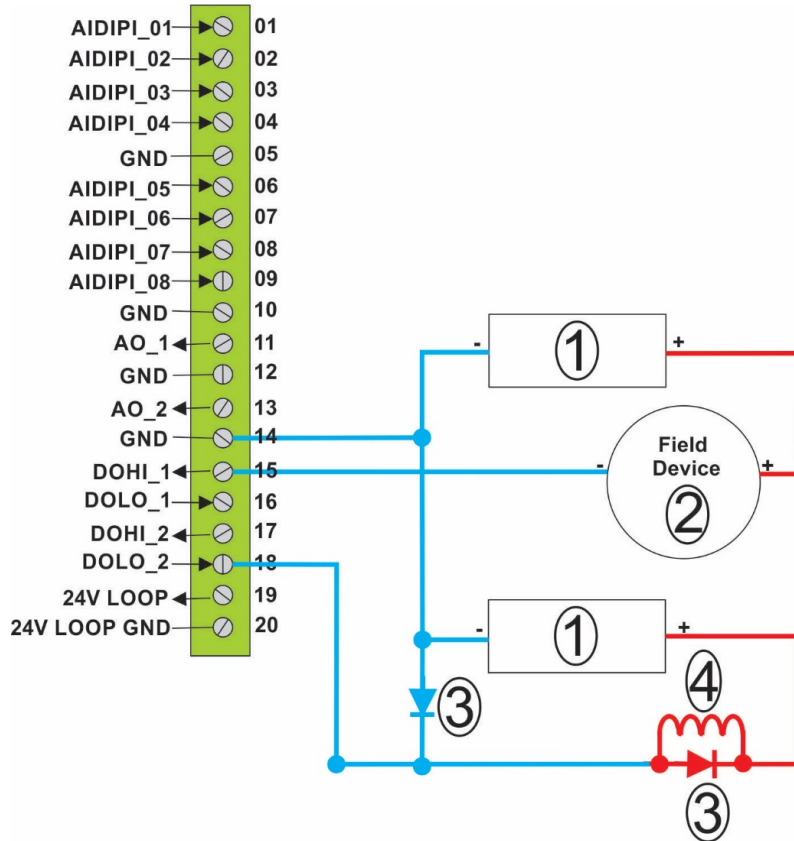

- 1 Power Supply 30VDC Max
- 2 Field device, 50 mA load max
- 3 Suppression diodes - typical placements
- 4 Switched load, relay coil shown

Note: The maximum load for the loop power output is 200 mA.

Digital Output (DO) Wiring using the internal Loop Power Output

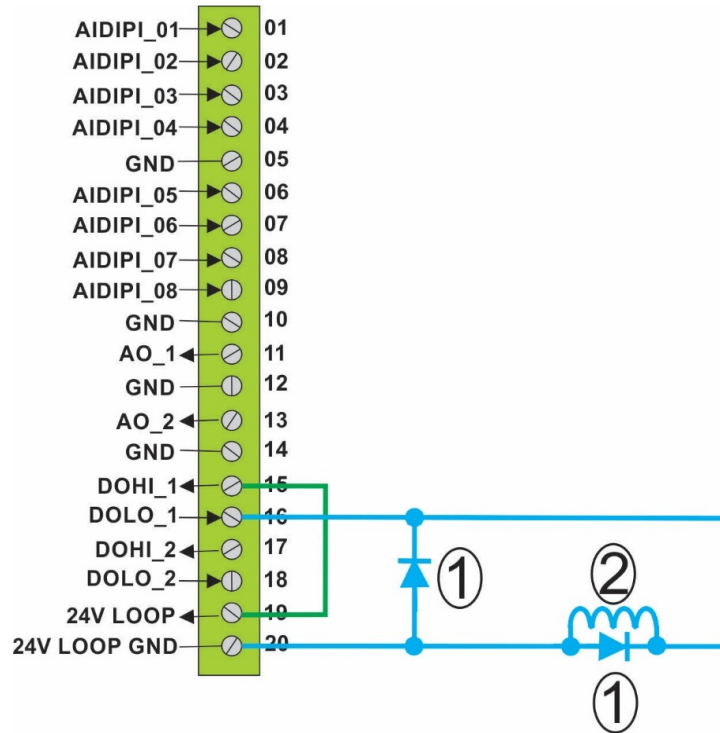

- 1 Suppression diodes typical placements
- 2 Switched load, relay coil shown

FBxRemote I/O™ Quick Start Guide

D301902X012

November 2023

Digital Output (DO) Wiring - Dry Contact Closure

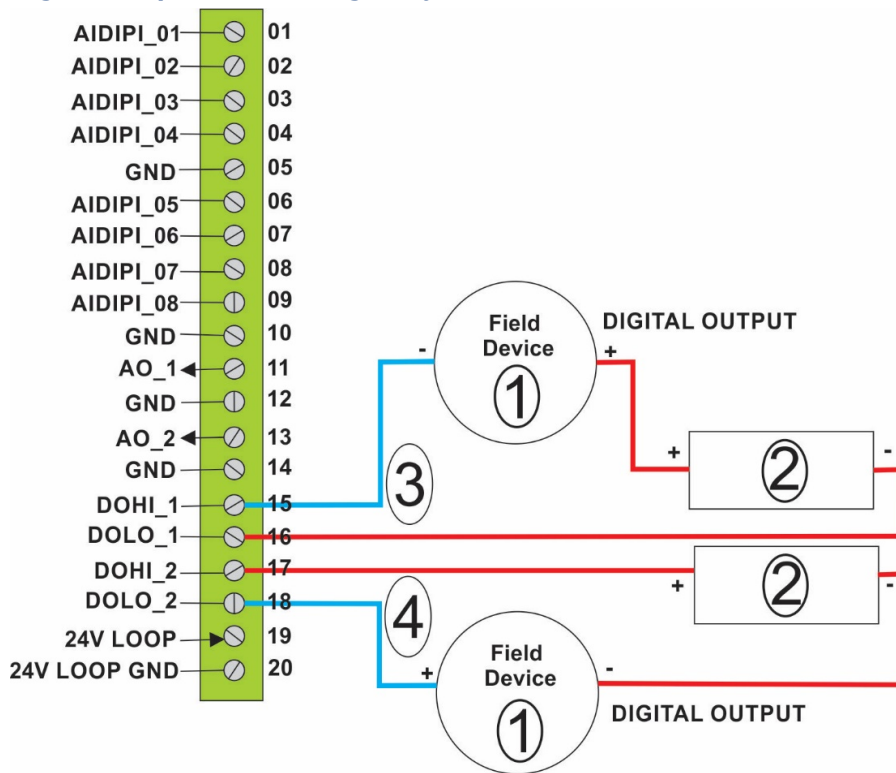

- 1 500 mA load max field device
- 2 30VDC Max Power Supply
- 3 DOHI_1/DOLO_1 configured as an internal dry contact
- 4 DOHI_2/DOLO_2 configured as an internal dry contact

Digital Output (DO) Wiring – Contact Closure using 24V Loop Supply

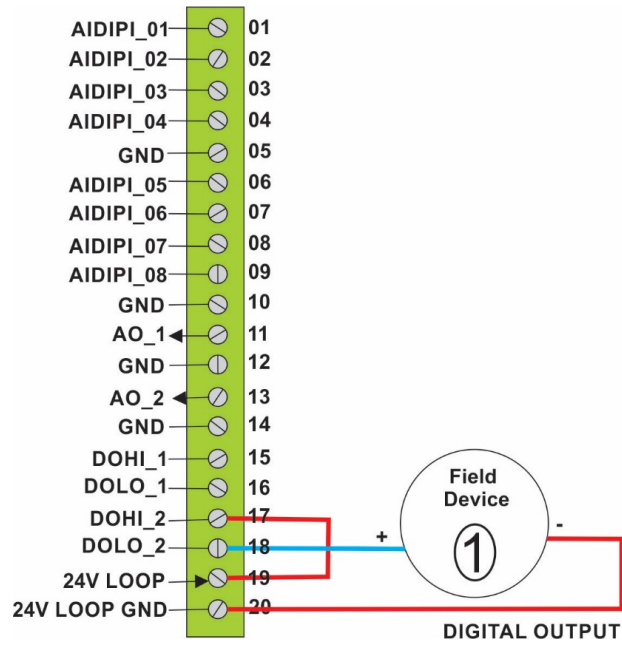

1 500 mA load max field device

Pulse Input (PI)

Pulse Input (PI) Wiring

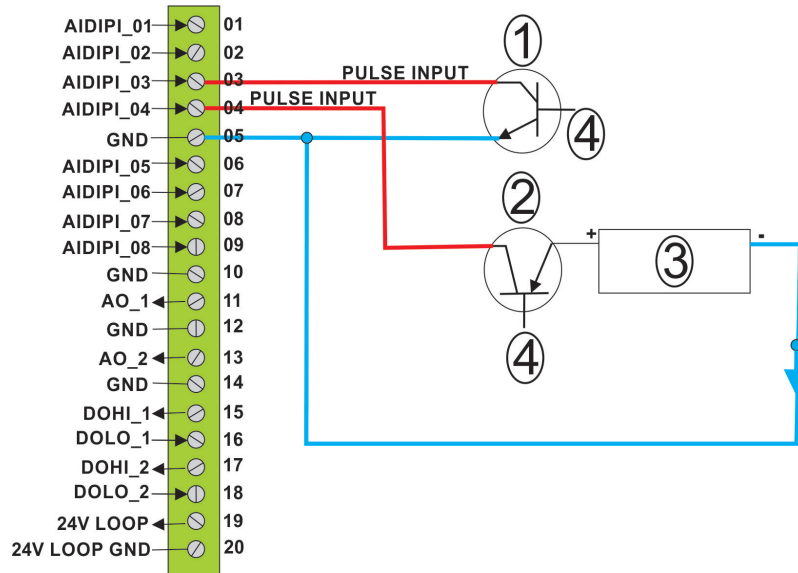

- 1 External Device (Because no power supply, requires internal pull-up to be enabled.)
- 2 External Device
- 3 30VDC Max Power Supply
- 4 Control signal

Wiring Power

⚠ DANGER

EXPLOSION HAZARD: Ensure the area in which you perform this option is non-hazardous. Performing this operation in a hazardous location could result in an explosion.

The device supports both 12V and 24V power supplies. It accepts DC voltage from 10.5 to 30V; the amount of power required varies depending upon the options used.

Controller power powers the RTU; field power can power attached field devices.

External Power Connections

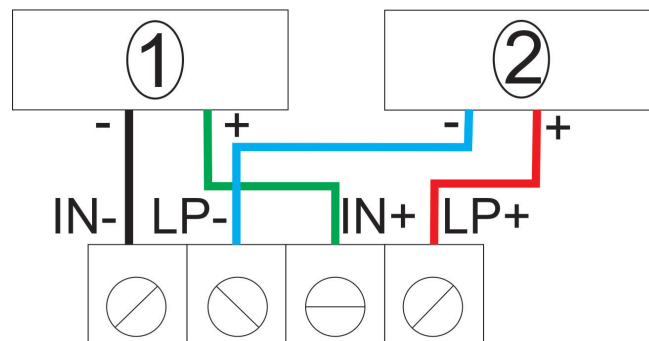

- 1 Input power from external power supply (power for RTU)
- 2 Loop power from external power supply (power for field devices)

Note If using extension chassis, only wire power to the base chassis.

Installing Field Tools Configuration Software

To configure the device, you install Field Tools 3.x software (which includes FBxConnect) on your PC.

Important

- Field Tools (including FBxConnect) is available as a free software download to registered [SupportNet](#) users. If you are not a registered SupportNet user, new accounts take up to 24 hours to process, so plan accordingly.
- If installing TechView, close all other programs down before you begin installation. In particular Office 365 components must be closed because they can interfere with the Field Tools installer.
- Field Tools **cannot** reside on a computer running any component of OpenEnterprise 2.x, OpenEnterprise 3.x, OpenEnterprise Client/Server, or ObjectServer software.
- TechView and other components of BSI_Config software **cannot** be installed on a computer running OpenBSI Network Edition versions older than 5.9 Service Pack 2.
- You must have administrative privileges to install Field Tools.
- You must disable User Account Control (UAC) prior to installing Field Tools (you can re-enable it after a successful installation).
- As part of the installation, software from both Eltima and MACTek® is automatically installed. Depending upon your permissions, Windows may require you to confirm these installations before the installation can proceed.

-
1. Right click on the installer file and choose **Run as administrator** from the pop-up menu.
 2. Follow the on-screen instructions. For details on minimum hardware/software requirements as well as more details on the installation steps see the *Field Tools Quick Start Guide (D301703X412)*.

Note

During Field Tools installation, you must select the **FBx support including FBxConnect** option. If you purchased FBxDesigner, you should also select the **FBxDesigner -FBx Application Development** option.

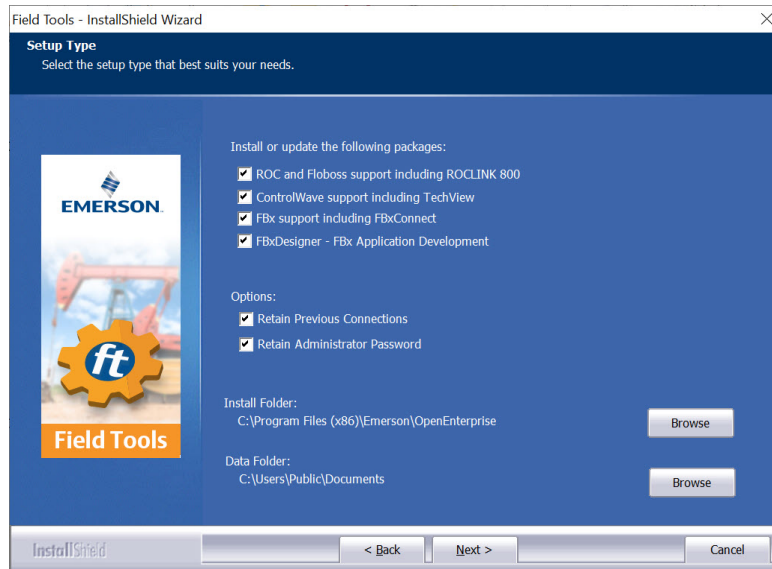

3. After software installation re-boot, start Field Tools from either the Windows Start Programs menu or (if you created it) from the desktop icon.
4. Log onto Field Tools.

Important

The very first time you login with Field Tools, use the default **username** of **admin** and leave the **password** field blank. Then assign a new password when prompted. See the [Field Tools Quick Start Guide \(D301859X012\)](#) for any questions you have on changing default passwords after installation.

Establishing a Connection and Configuring Remote I/O

⚠ CAUTION

When making multiple FBxConnect connections to the same device (as with a remote and a local connection), be aware that the changes one connection makes to the device may not be immediately visible to other connections and may even require the other connections to restart FBxConnect before changes become visible. For example, simple changes (such as changes to setpoints) may be immediately visible to all connections, but changing the number of meters, configuring I/O, adding/deleting menu items, or other major configuration changes may require re-establishing the connection using FBxConnect.



Important

The FBxRemote I/O rack provides extra I/O for an FB3000 RTU. During configuration you can connect to it either through an Ethernet cable or a serial cable. When placed in service the FB3000 RTU host only communicates to the I/O rack using Ethernet.

You must configure an IP address and a DNP address for the FBxRemote I/O rack. Once this is done, you can configure the I/O points and FBxNet™ connections either locally, or remotely through the host RTU.

Connecting to the FBxRemote I/O

1. Click **Connections > Add connection.**

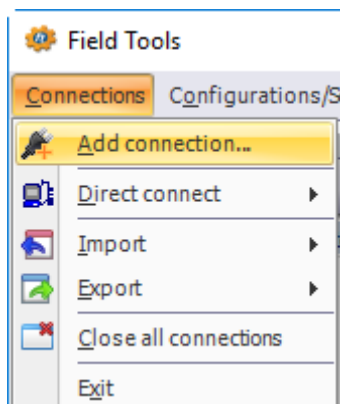

2. Choose **FBx** as the Device Platform.

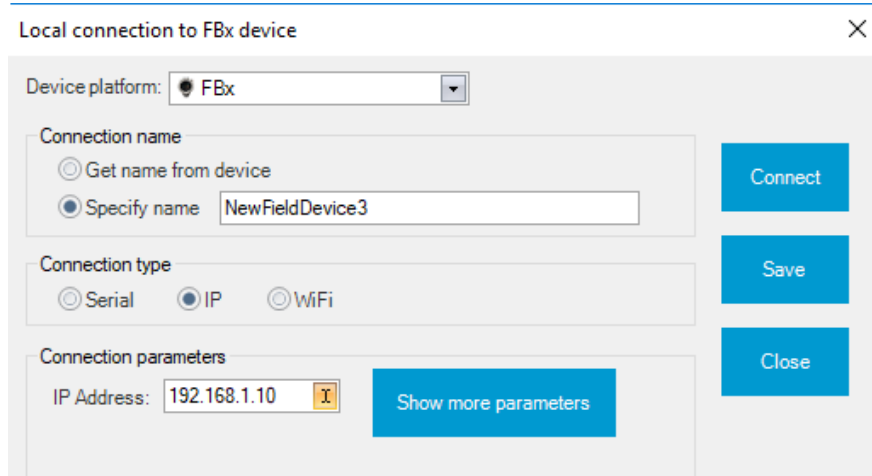

3. Choose the Connection Type

- For **serial**: choose the PC Comm port (or the port for the USB/serial adapter). COM 1 defaults to DNP3, 115200 BAUD, 8 data bits no parity 1 stop bit, RS-232.



- For **IP**: Enter the default IP Address for the Ethernet Port 1 of **192.168.1.10**. (Your PC must be able to access this address.)

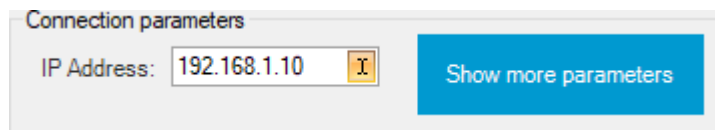

- **WiFi**: The FB3000 does not currently support WiFi.
4. Click **Connect**. Field Tools activates the connection and automatically launches the FBxConnect tool.
 5. If prompted, enter the Username and Password. Initially this is **admin** for both.

Important

When you finish initial configuration activities, be sure you **change the password for the admin user**. Otherwise, anyone reading this document could gain access to your device.

Configuring the IP Address and DNP3 Address of the Remote I/O

1. When FBxConnect opens, click **Configure**, then click **Communications**.

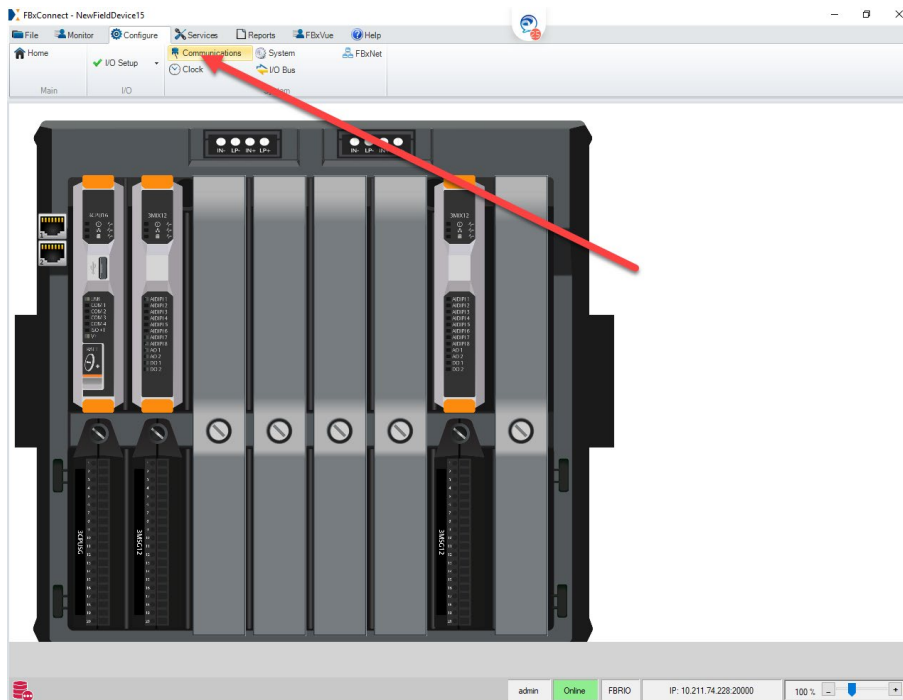

2. Click on the ports drop-down and select the Ethernet Port which the FBxRemote I/O rack will use to communicate with its host RTU.

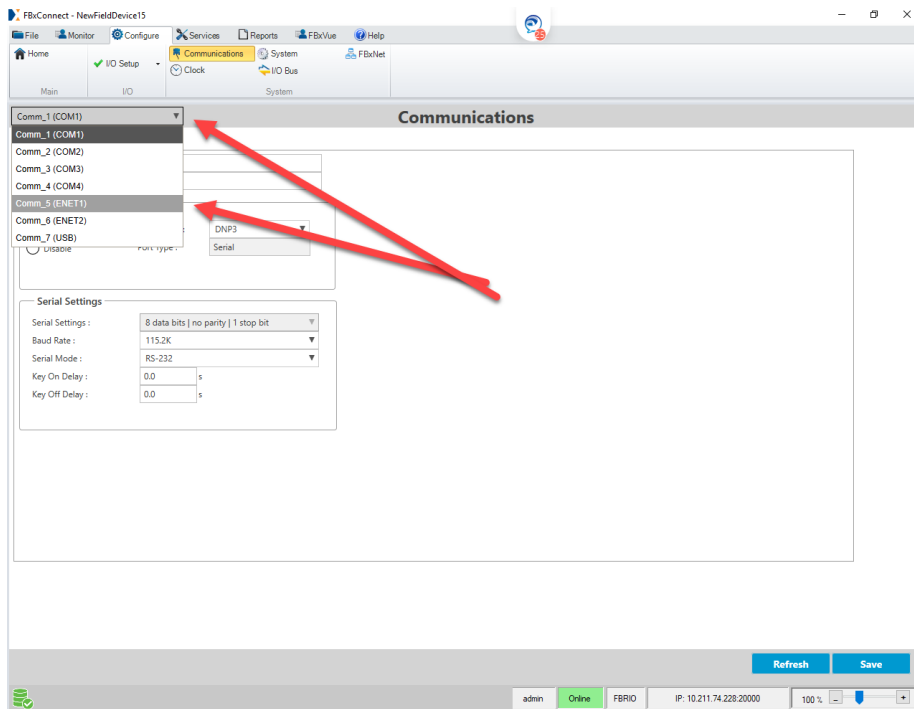

3. On the General tab for the Ethernet Port enter the IP address you want to use in the **IPv4 IP Address** field, then click **Save**.
4. Click the DNP tab then specify the DNP address for the rack in the **Flow Computer Address** field, then click **Save**.

FBxRemote I/O™ Quick Start Guide

D301902X012

November 2023

The screenshot shows the 'Communications' configuration page for the 'DNP3' tab. The page is divided into several sections:

- General:** Includes 'Flow Computer Address' (1), 'Require Login' (checked), and 'TCP/IP Port' (20000).
- Timeouts:** Includes 'Master Confirmation Timeout' (10000 ms) and 'Inactivity Timeout' (120 s).
- Event Log:** Includes 'Maximum Binary Input events' (17), 'Maximum Analog Input events' (115), 'Maximum Binary Counter events' (10), and 'Maximum Frozen Counter events' (0). It also includes 'Group 2 Scan Period', 'Group 32 Scan Period', and 'Group 22 Scan Period' (all 0 s).
- Active DNP3 Map:** Includes 'Default' and 'User Defined' radio buttons, and a 'DNP3 Mapping' button.
- Unsolicited Messages:** Includes 'Enable' and 'Disable' radio buttons (Disable selected), 'Unsolicited Destination Address' (0), 'Unsolicited Confirmation Timeout' (10000 ms), 'Unsolicited Number of retries' (3), and 'Delay between unsolicited retries' (30000 ms). It also includes 'Class 1', 'Class 2', and 'Class 3' settings for 'Enable/Disable', 'Max Delay' (5000 ms), and 'Max Events' (5).

Red arrows point to the 'DNP3' tab, the 'Flow Computer Address' field, the 'TCP/IP Port' field, and the 'Save' button.

Enabling Unsolicited Message Option will prevent FBxConnect communications

Refresh Save

admin Online FBRIO IP: 10.211.74.228:20000 100%

Example - Configuring I/O in the FBxRemote I/O

I/O in the FBxRemote I/O rack is configured the same way as you configure I/O in the FB3000 host device. You can connect locally to the rack, as described in *Connecting to the FBxRemote I/O* and run FBxConnect to configure the I/O. This example, however, shows how to connect to the remote I/O through the FB3000 host RTU.

1. In Field Tools, launch an existing IP connection to the host FB3000 RTU.

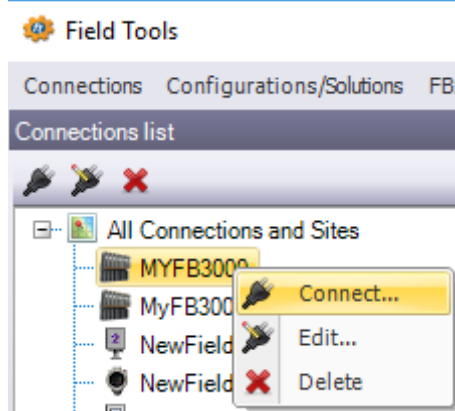

2. When FBxConnect opens, click the **Configure** tab, then click **Pass Thru**.

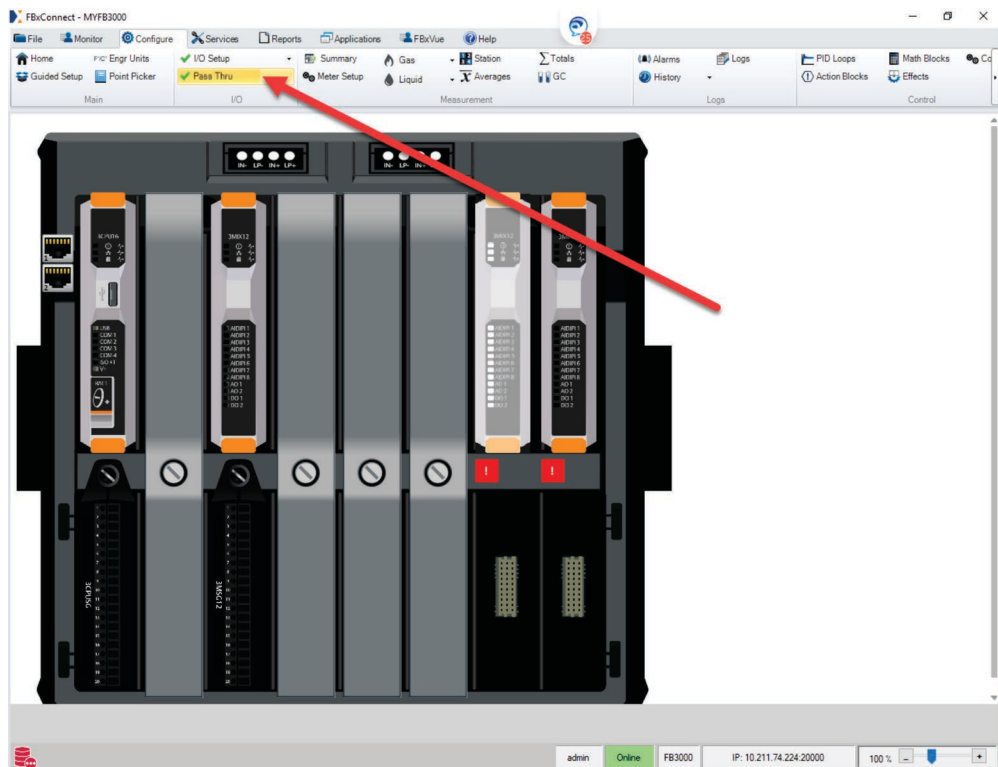

FBxRemote I/O™ Quick Start Guide

D301902X012

November 2023

- When Pass Thru screen opens, select the rack you want to connect to (If there's more than one), enter the IP address of the rack in the **Rack IP Address** field, then specify the **Rack DNP Address**, then click **Connect via Pass Thru**.

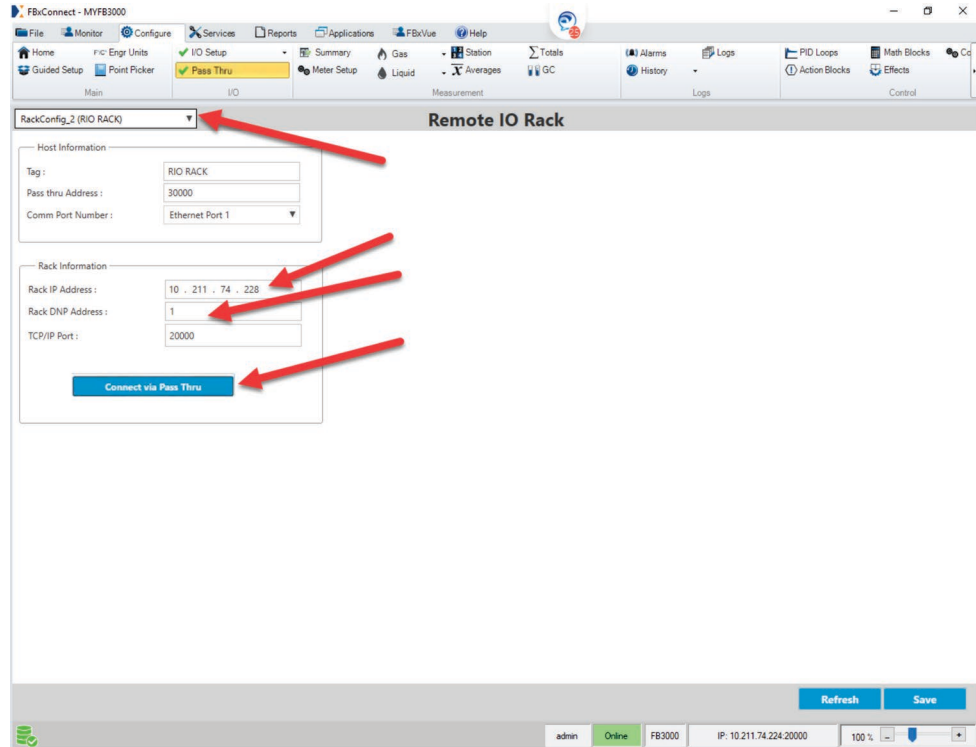

- You will notice that the FBxConnect ribbon changes to reflect only those options available for the FBxRemote I/O rack.

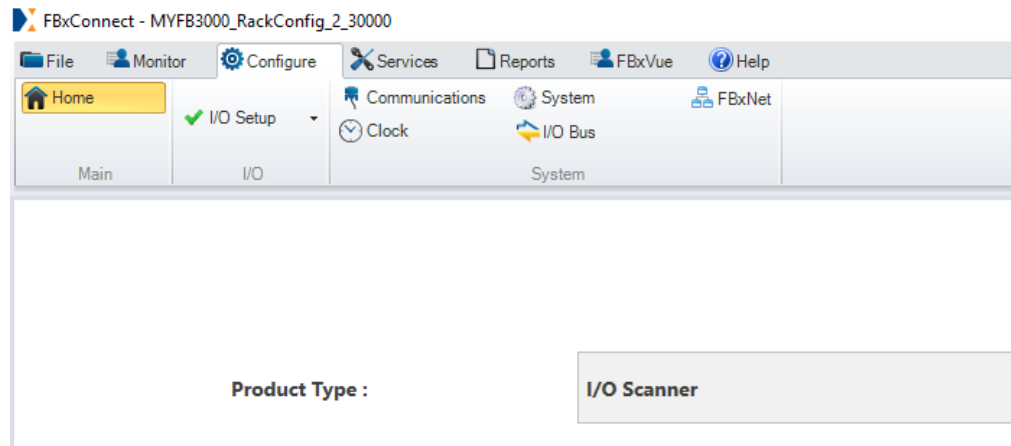

- You will notice that the FBxConnect ribbon changes to reflect only those options available for the FBxRemote I/O rack. For this example, click the **Configure** tab and choose **IO Setup > AI**.

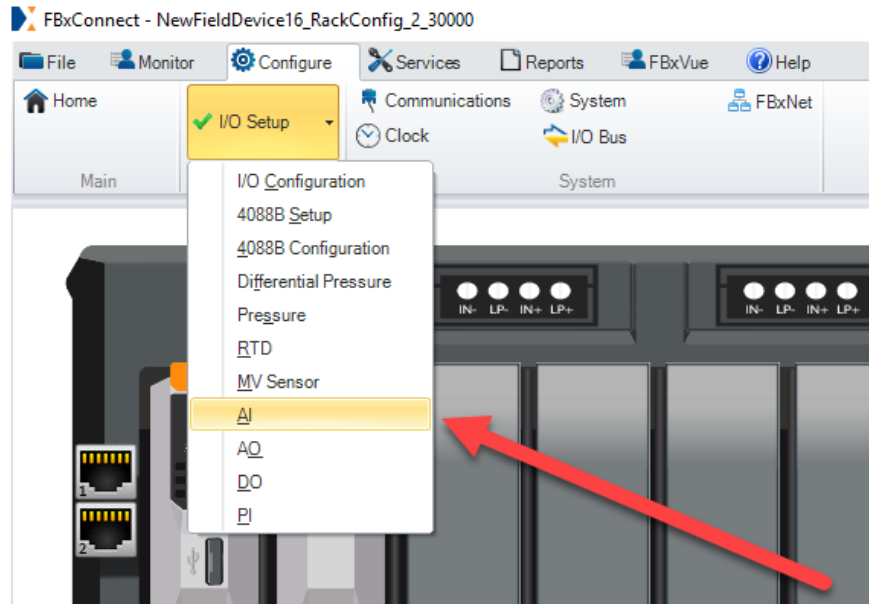

- You will notice that the FBxConnect ribbon changes to reflect only those options available for the FBxRemote I/O rack. For this example, click the **Configure** tab and choose **I/O Setup > AI**. You can now configure the AI as you would any AI in the host RTU. See the online help for information on I/O configuration and details of specific fields.

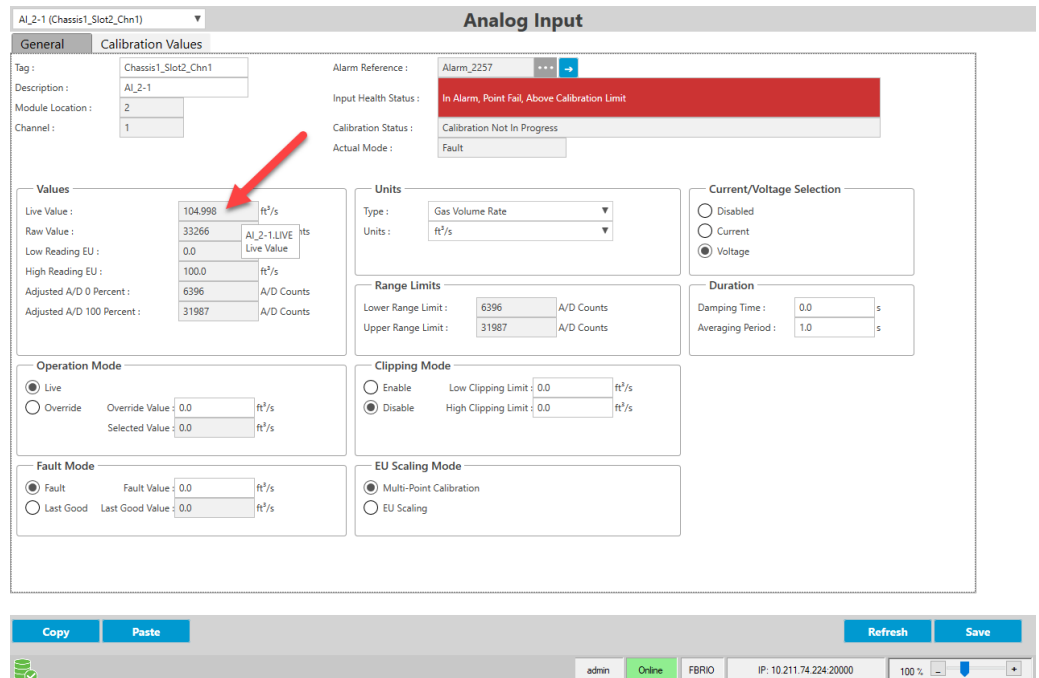

Example – Transferring Data from the FBxRemote I/O to the Host RTU

You must configure FBxNet™ software for data transfer between the host RTU and the FBxRemote I/O rack. FBxNet requires an Ethernet connection.

Note

Full details on FBxNet™ configuration are included in *Chapter 4* of the *Field Tools Quick Start Guide* or in Field Tools online help. This example shows how to transfer a single value from the rack to the host RTU. If you are transferring large amounts of data, it may be easier to manually edit CSV files in Excel or a text editor than use the steps shown here.

Before You Begin

Before you begin, you must have **active** Field Tools connections with both the FB3000 RTU and the FBxRemote I/O rack.

Also, you must create an FBxNet user in **each** device that uses FBxNet. In this case, that means you must create an FBxNet user in the FB3000 host RTU, and then create an identical FBxNet user in the FBxRemote I/O rack. You create an FBxNet user within FbxConnect as follows:

1. Click **Services > User Management**
2. In the User Management screen, click **Add User**

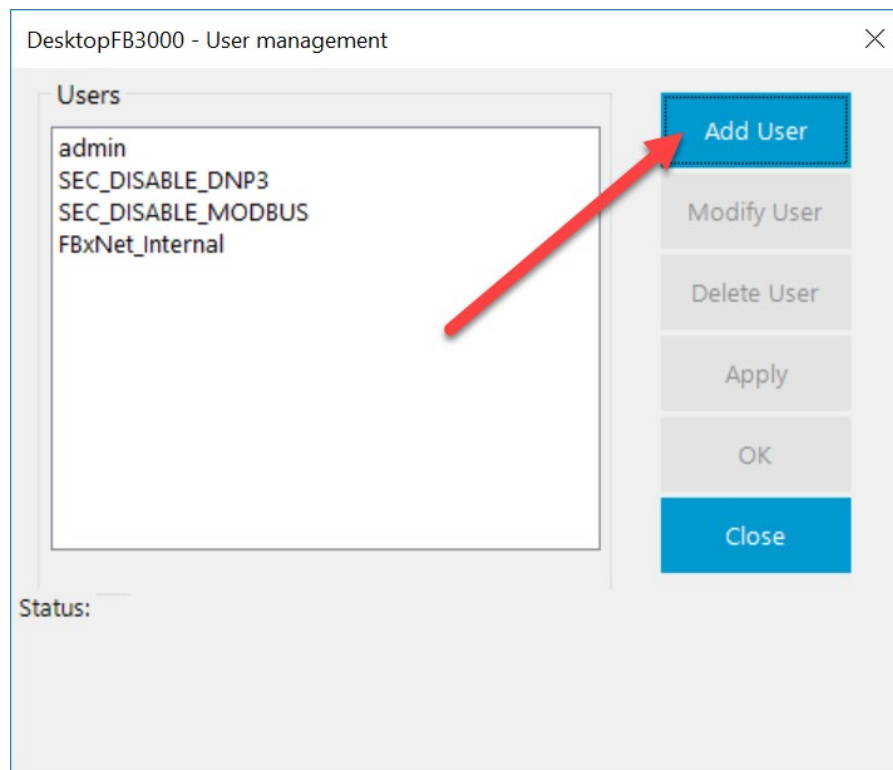

3. For the user details:

- Select **FBxNet** as the **Protocol Type**.
- Specify a **Username** and **Password** combination. All FBxNet users you define on your network must share this same username/password combination.
- Specify the **Role** for the user; **Admin** provides the most access; **Auditor** provides the least access.

FBxRemote I/O™ Quick Start Guide

D301902X012
November 2023

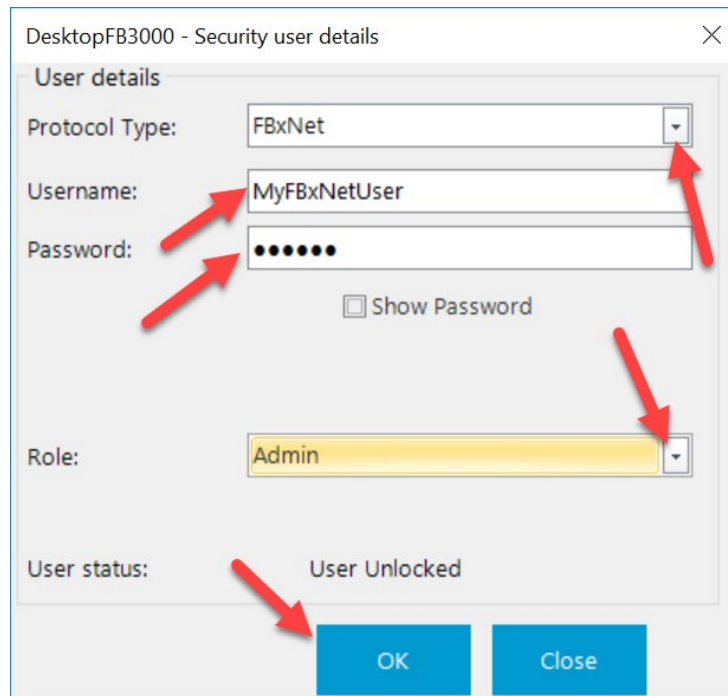

4. Click **OK** to save your changes, and **OK** to exit the User Management screen.

Configuring FBxNet to Transfer Data

1. In Field Tools, click **FBxNet**

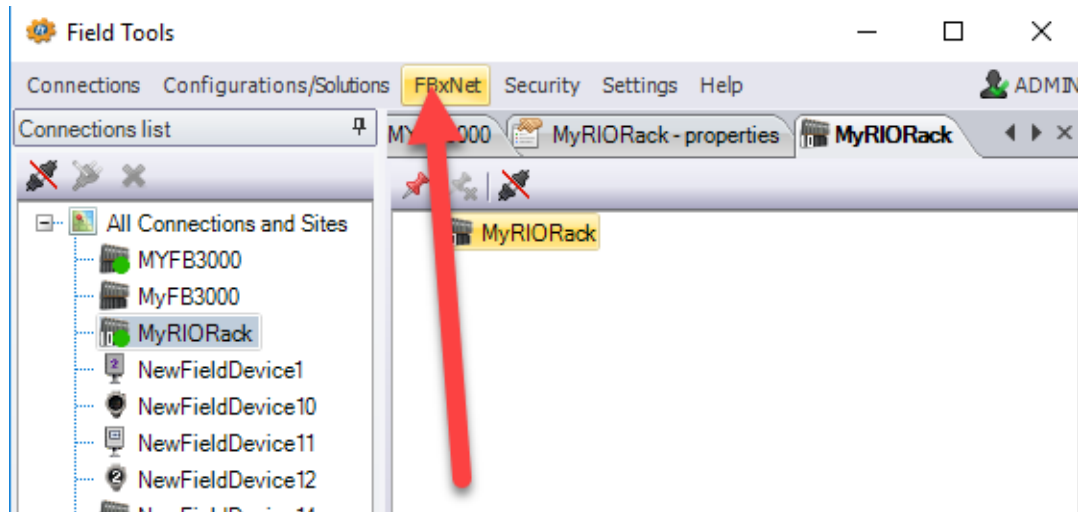

2. In FBxNet, click the Add Site  I con.

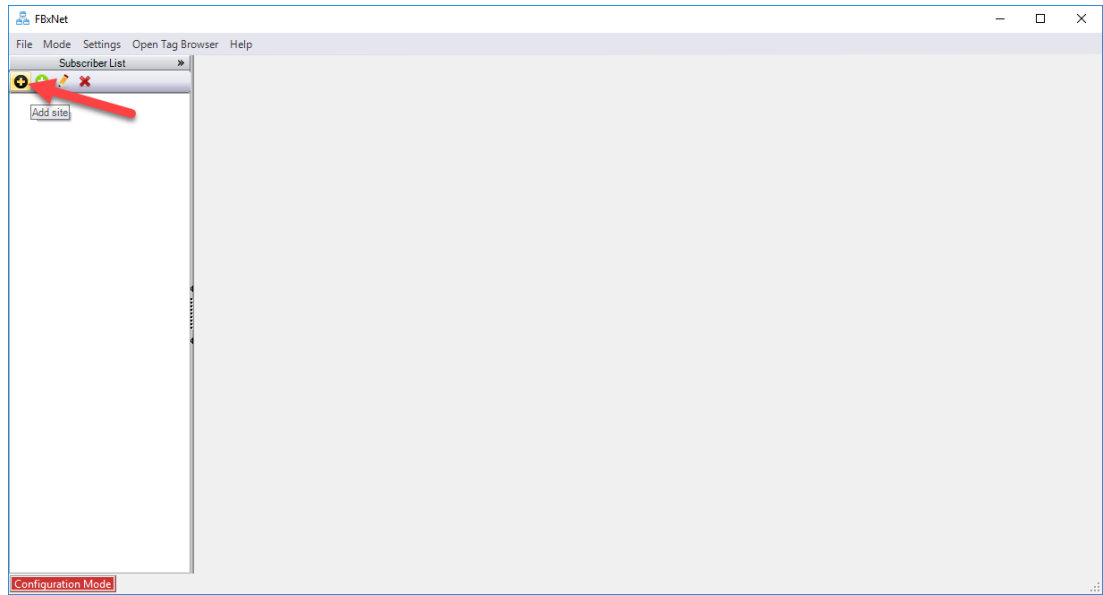

3. This creates an icon for the site in the Subscriber List pane. Specify a **Site Name** (here we used "CENTRAL") then check the box for specifying a designated device and enter the **Designated Device IP Address**. For this example, this address is the IP port on the host FB3000 RTU that communicates with the FBxRemote I/O rack. Click **Save** when finished.

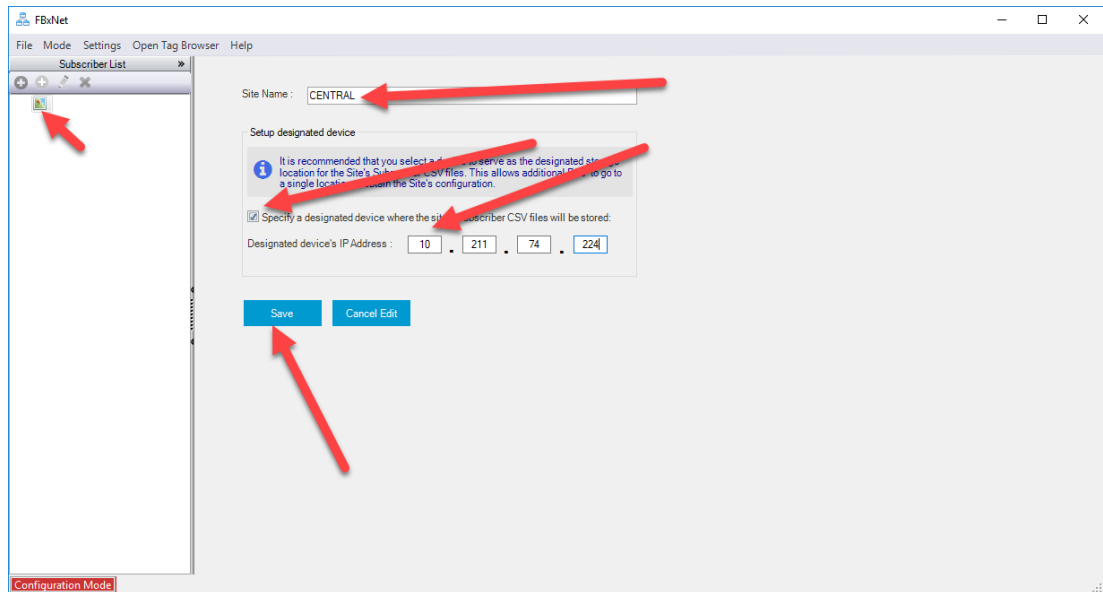

4. Now you'll notice the site name gets added, and the name of the RTU you specified as the designated device shows below it. (This name might not necessarily be the same name you use in Field Tools, it's the RTU name stored in the RTU.)

For the **Subscriber Name** and **IP Address**, enter the name and IP address of your FB3000 host RTU. Then click **Add Publisher**.

FBxRemote I/O™ Quick Start Guide

D301902X012

November 2023

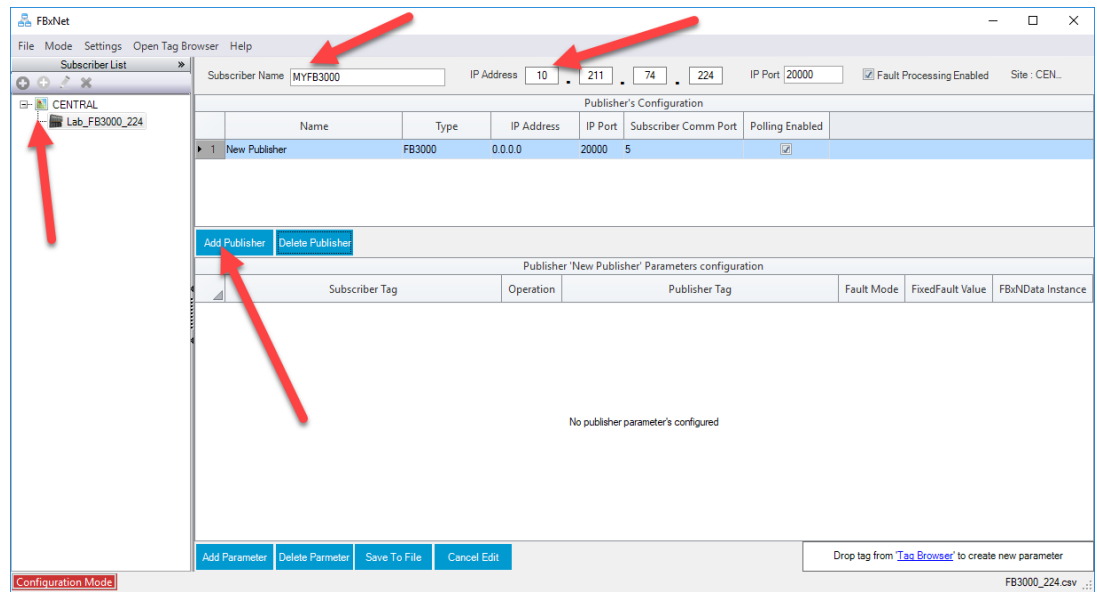

5. The publisher is your FBRIO rack so edit the **Name** field to make it the name of the FBxRemote I/O rack and enter the **IP Address** for the FBxRemote I/O rack.

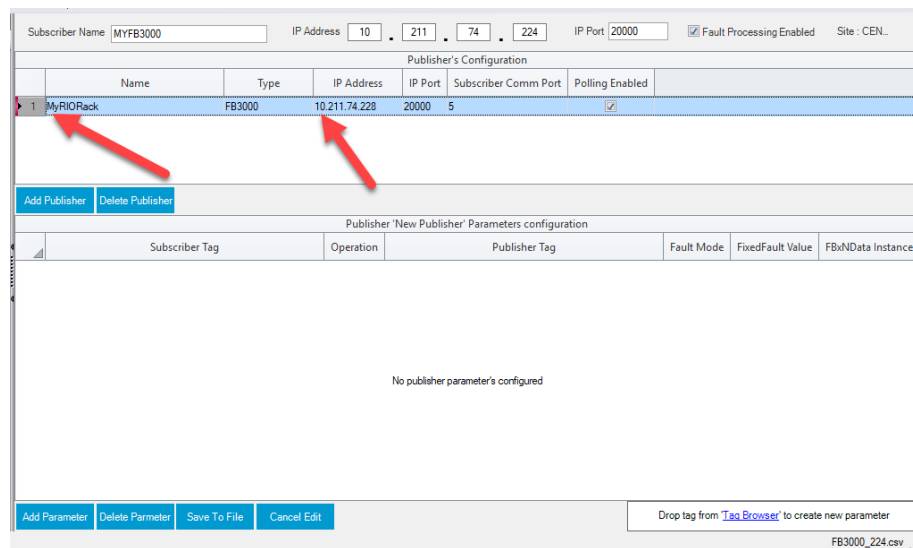

- Click **Add Parameter** and a new line is added in the Publisher Parameters Configuration pane.

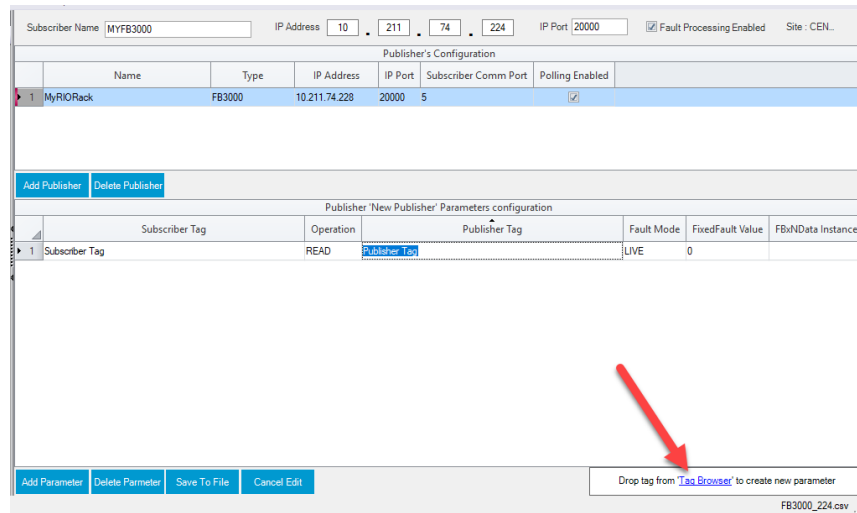

- Click **Tag Browser** (or **Open Tag Browser** in the menu bar). Select the **Device name** (in this case it's your FBxRemote I/O rack), then choose the **AI** you want and its associated parameter (in this case **Live Value**) finally click **Copy Tag**.

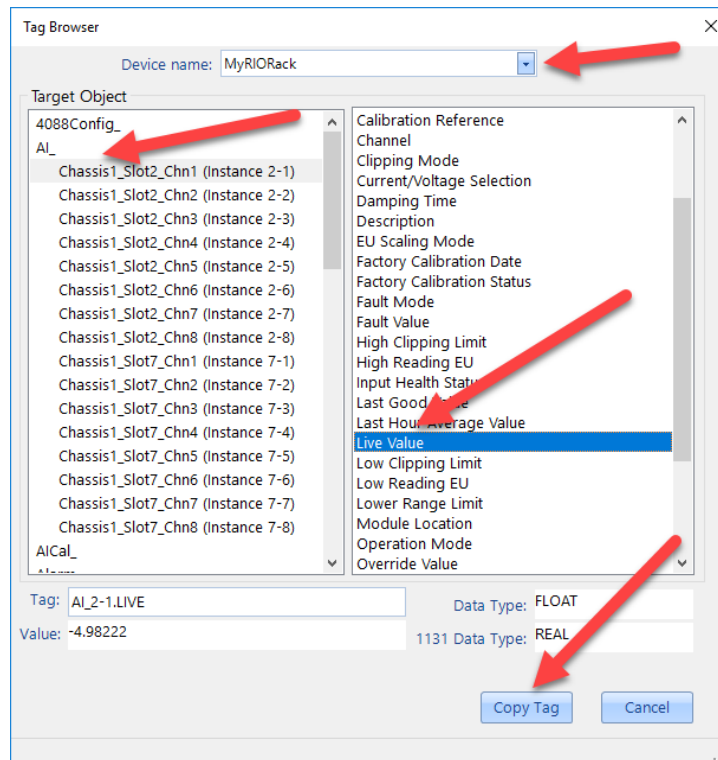

FBxRemote I/O™ Quick Start Guide

D301902X012

November 2023

- In the Publisher Parameters Configuration pane, click in the **Publisher Tag** field, and right click to paste in the tag you copied from the Tag Browser.

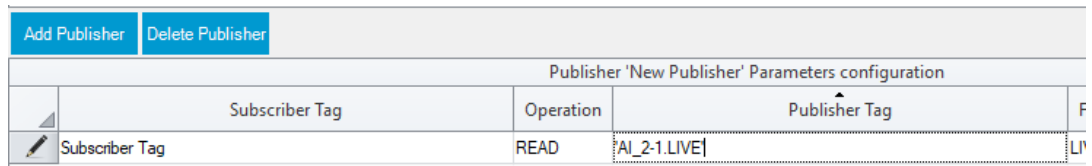
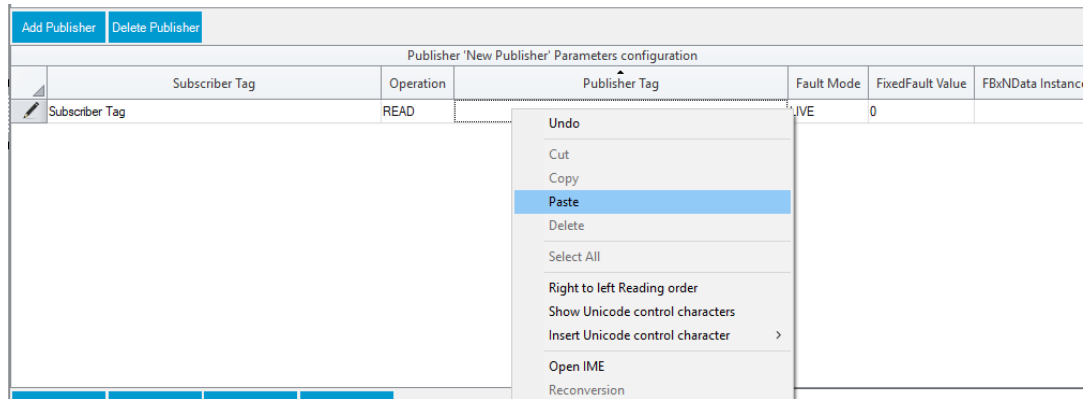

- Now go back to the Tag Browser and select the **Device name** (in this case it's your FB3000 host RTU), then choose the destination parameter (in this case **Primary Process Variable Input** to PID Loop 1) then finally click **Copy Tag**.

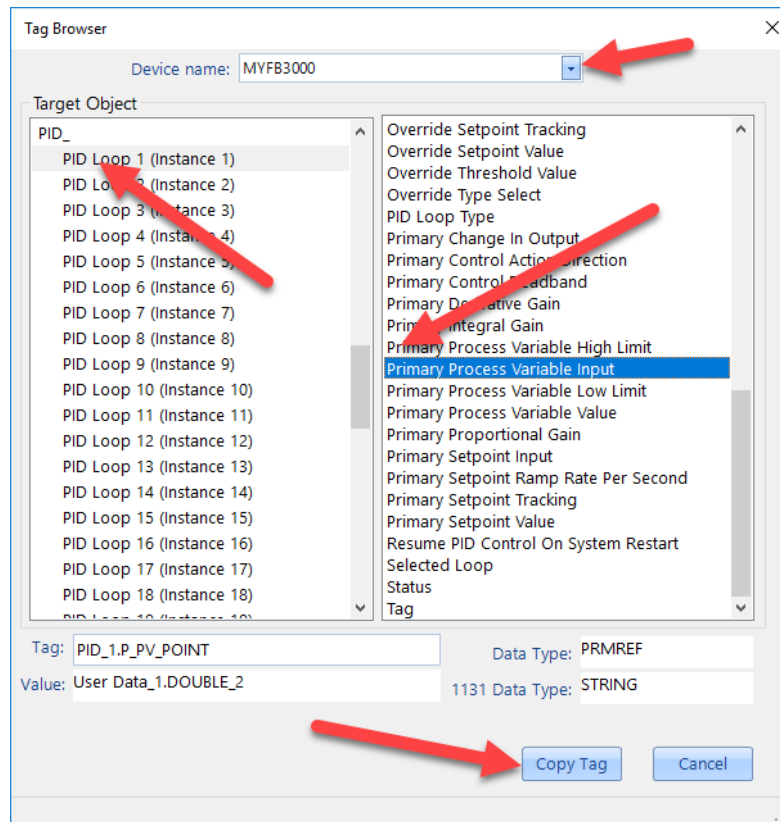

10. Now paste the copied tag into the **Subscriber Tag** field.

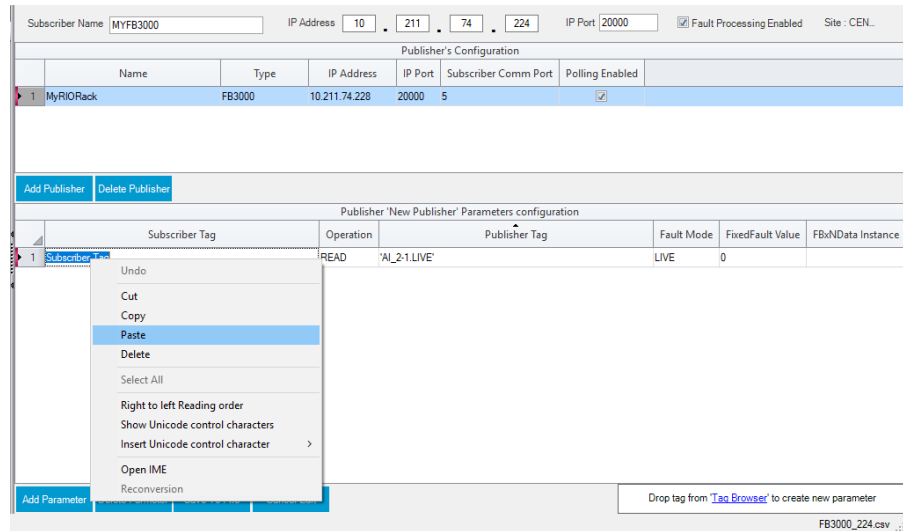

FBxRemote I/O™ Quick Start Guide

D301902X012

November 2023

11. This completes the definition of the parameter. You can repeat this entire process for other parameters you want to transfer. When finished, click **Save To File** to save the CSV file.

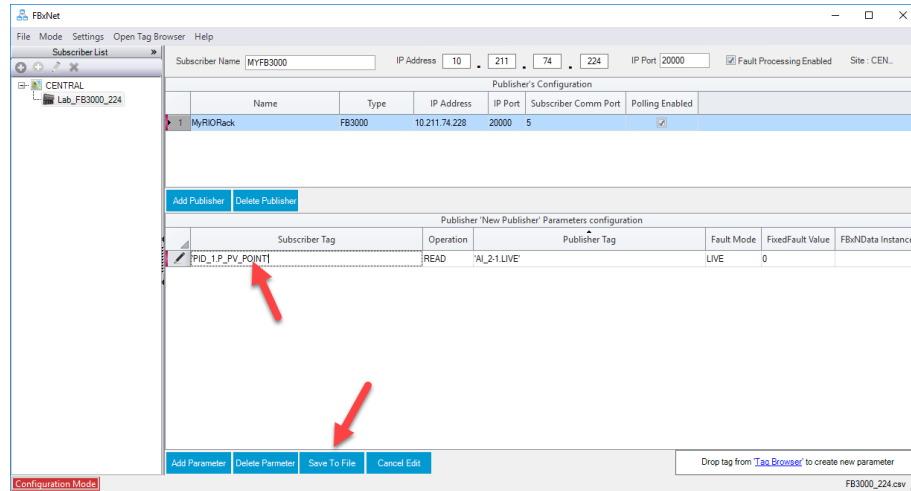

12. Now click **File > Download files** to update the CSV files in the subscriber(s). You're done!

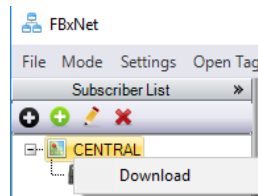

FBxRemote I/O Quick Start Guide

D301902X012

November 2023

For customer service and technical support, visit [Emerson.com/SupportNet](https://www.emerson.com/SupportNet).

North America and Latin America:

Emerson Automation Solutions
Energy and Transportation Solutions
6005 Rogerdale Road
Houston, TX 77072 U.S.A.
T +1 281 879 2699 | F +1 281 988 4445
[Emerson.com/SCADAforEnergy](https://www.emerson.com/SCADAforEnergy)

United Kingdom:

Emerson Automation Solutions
Meridian East
Meridian Business Park 7
Leicester LE19 1UX UK
T +44 0 870 240 1978
F +44 0 870 240 4389

Europe:

Emerson S.R.L
Regulatory Compliance Shared Services
Department
Company No. J12/88/2006
Emerson 4 Street
Parcul Industrial Tetarom 11
Romania
T +40 374 132 000

Middle East/Africa:

Emerson Automation Solutions
Energy and Transportation Solutions
Emerson FZE
P.O. Box 17033
Jebel Ali Free Zone – South 2
Dubai U.A.E.
T +971 4 8118100 | F +971 4 8865465

Asia-Pacific:

Emerson Automation Solutions
Energy and Transportation Solutions
1 Pandan Crescent
Singapore 128461
T +65 6777 8211 | F +65 6777 0947

© 2021-2023 Bristol Inc., an affiliate of Emerson Electric Co. All rights reserved.

This publication is for informational purposes only. While every effort has been made to ensure accuracy, this publication shall not be read to include any warranty or guarantee, express or implied, including as regards the products or services described or their use or applicability. Bristol Inc. (hereinafter “Energy and Transportation Solutions” or ETS) reserves the right to modify or improve the designs or specifications of its products at any time without notice. All sales are governed by ETS terms and conditions which are available upon request. ETS accepts no responsibility for proper selection, use or maintenance of any product, which remains solely with the purchaser and/or end-user. Emerson Automation Solutions, Emerson, and the Emerson logo are trademarks and service marks of Emerson Electric Co. All other marks are the property of their respective owners.