

- 1) 1.50-11 NPT (2 Plcs) is preferred wire entry. CAUTION Conduit must enter at lowest point to prevent water from entering electrical enclosure due to condensation. If hazardous (classified) or Nema 6 location, conduit seal required at electrical enclosure entrances.
- 2) Lubrication $\frac{1}{2}$ -14 NPT plugs.
- 3) P/N 34706 Bushing. Maximum bore stem size is 2.00" (1/2 Sq Key)
- 4) For electrical control pilot device elements mounted on actuator control cover, see EIM job spec sheet & wiring diagram furnished for each specific job no.
- 5) WARNING - The installation and servicing instructions are for use by qualified personnel only. To avoid injury and electric shock, do not perform any service on EIM equipment unless qualified.
- 6) Installation shall be in accordance with current edition of National Electrical Code.

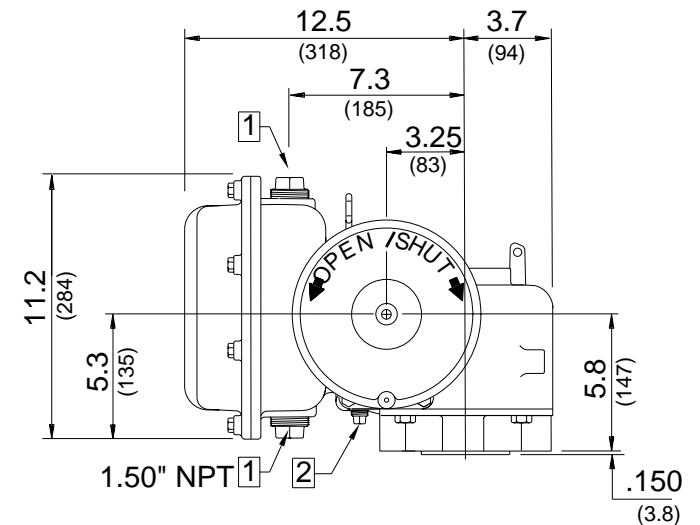
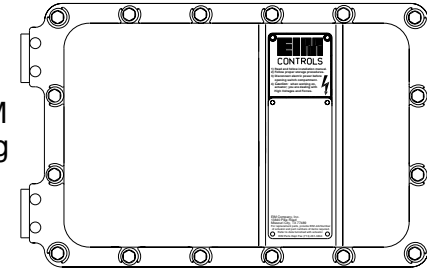

INCHES .XXX ± .005"
(MILLIMETERS) .XX ± .020"
.X APPROX.

EIM EIM COMPANY, INC.
13840 PIKE ROAD
CONTROLS MISSOURI CITY, TX 77489

TITLE **Type U M/T 5.50**

C	3/7/01	13561	LHE/c	OUTLINE NO. U-0001/14G	REV C
REV	DATE	ERO	BY		