

ISSUE	CHANGE ORDER No	WEEK	ISSUE	CHANGE ORDER No	WEEK	ISSUE	CHANGE ORDER No	WEEK
1	SME-6097	1012	2	SME-7153	1141	3	SME-7572	1351

HAZARDOUS LOCATION

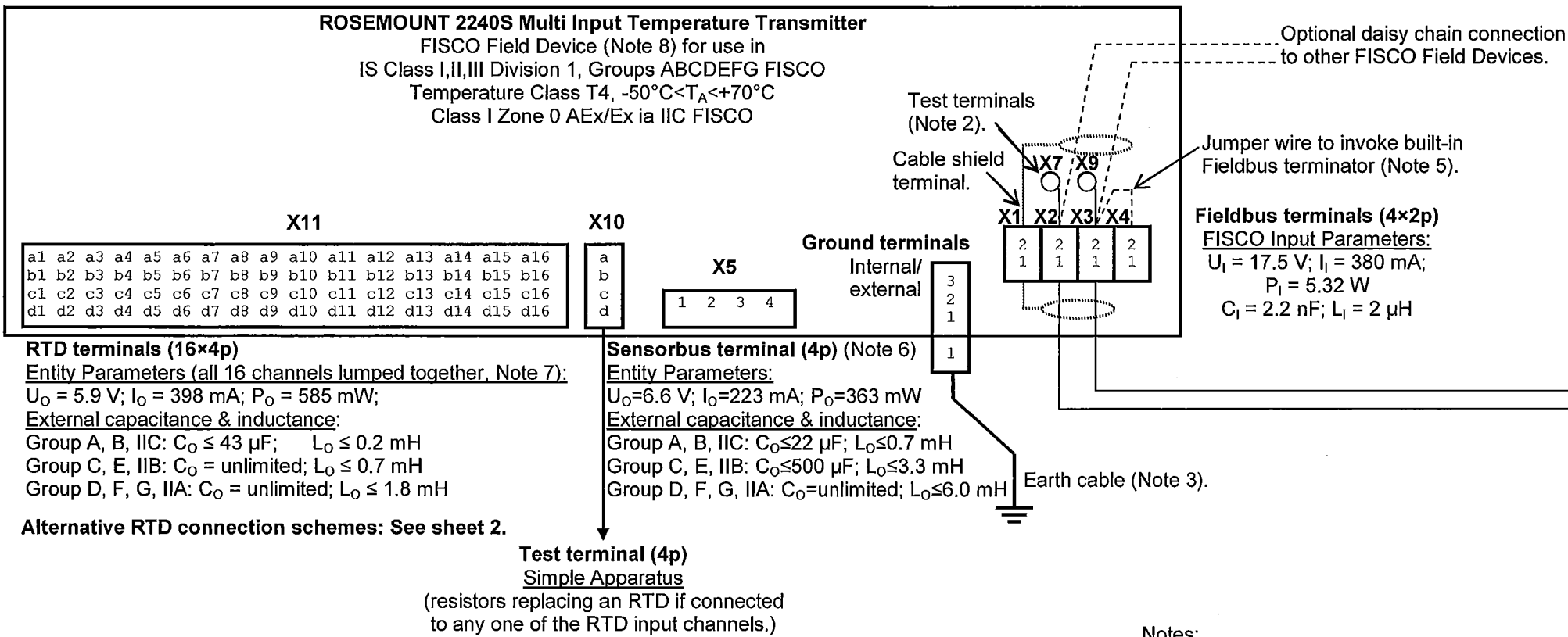

HAZARDOUS OR NON-HAZARDOUS LOCATION

FISCO power supply
 (Associated Apparatus, Note 1.)
 FISCO Parameters:
 U_O ≤ 17.5 V; I_O ≤ 380 mA
 P_O ≤ 5.32 W
 C_O, L_O: Unspecified
 C_I ≤ 5 nF; L_I ≤ 10 μH

Notes:

- Control equipment connected to the Associated Apparatus must not use or generate more than 250 V_{RMS} or V_{DC}.
- Test terminals for temporary connection of Intrinsically Safe Rosemount 375 or 475 Field Communicator.
- Earth connection cable area: min. 4 mm².
- Installation in the USA should be in accordance with ANSI/ISA-RP12.6 "Installation of Intrinsically Safe Systems for Hazardous (Classified) Locations" and the National Electrical Code (ANSI/NFPA 70).
 Dust tight conduit seals must be used when installed in Class II and Class III environments.
- It is possible to disconnect the integrated termination by removing the jumper wire in X3:2-X4:2.
- The Sensorbus terminal is a separate IS circuit and connection of external sensors must be made through a separate shielded cable with the shield connected to one of the Internal Ground terminals.
- Alternative entity parameters applicable to the RTD terminals (X11) when nothing is connected to the Sensorbus terminal (X5): U_O = 5.9 V; I_O = 100 mA; P_O = 150 mW; C_O = 43 μF; L_O = 3.0 mH (Group A, B, IIC)
- When supplied from a certified AEx/Ex [ib] FISCO Power Supply with triplicated output voltage limitation meeting the requirements for two faults ("ia" voltage limitation):
 Class I Zone 1 AEx/Ex ib [ia] IIC FISCO

FIELDBUS INTRINSICALLY SAFE CONCEPT (FISCO) APPROVAL

FISCO allows interconnection of intrinsically safe apparatus to associated apparatus not specifically examined in such combination. The criteria for interconnection is that the voltage (U_I or V_{MAX}), current (I_I or I_{MAX}) and power (P_I or P_{MAX}) which an intrinsically safe apparatus can receive and remain intrinsically safe considering faults, must be equal to or greater than the voltage (U_O, V_{OC} or V_I), current (I_O, I_{SC} or I_I) and power (P_O or P_{MAX}) levels which can be delivered by the Associated Apparatus, considering faults and applicable factors. In addition, the maximum unprotected capacitance (C_I) and the inductance (L_I) of each apparatus (other than the termination) connected to the Fieldbus must be less than or equal to 5 nF and 10 μH respectively.

In each I.S. Fieldbus segment only one active device, normally the Associated Apparatus, is allowed to provide the necessary energy for the Fieldbus. The voltage (U_O, V_{OC} or V_I) of the Associated Apparatus is limited to a range of 14 V to 17.5 V. All other equipment connected to the bus cable has to be passive, meaning that they are not allowed to provide energy to the system, except a leakage current of 50 μA for each connected device. Separately powered equipment needs galvanic isolation to assure that the intrinsically safe Fieldbus circuit remains passive.

The cables used to interconnect devices need to have characteristics in the following range:

- Loop Resistance R_C: 15.....150 ohm/km
- Loop Inductance L_C: 0.4.....1 mH/km
- Capacitance per unit length C_C: 45.....200 nF/km
- C_C=C_{line to line} + 0.5×C_{line to screen} if both lines are floating or
- C_C= C_{line to line} + C_{line to screen} if screen is connected to one line
- Length of trunk cable: Less than or equal to 1 km
- Length of spur cable: Less than or equal to 60 m

At each end of the trunk cable an approved infallible line terminator with the following parameters should be installed: R ≥ 90 ohm, C ≤ 2.2 μF (recommended parameters are: R = 100 ± 2 ohm, C = 1.0 ± 0.2 μF). One of the allowed terminations may be integrated in the Associated Apparatus. This Field Device is also equipped with an integrated terminator; see note 5. FISCO limits the number of passive devices connected to a single segment to 32 devices. If the above rules are respected, a total length of up to 1 km of cable is permitted (sum of trunk and spur cables). The inductance and capacitance of the cable will not impair the intrinsic safety of the installation.

WARNING: To prevent ignition of flammable or combustible atmospheres, read, understand and adhere to the manufacturer's live maintenance procedures.
WARNING: Substitution of components may impair Intrinsic Safety.

FM APPROVED PRODUCT
 No revision to this drawing without prior Factory Mutual approval

9240040-910	ISSUED BY EE-RJ	WEEK 1012	PRODUCT CODE 2240	TITLE SYSTEM CONTROL DWG
	APPROVED BY EAp	WEEK 1012	DOC. TYPE 6	FILE
	ALL DIMENSIONS ARE IN MILLIMETRES. TOLERANCES, UNLESS OTHERWISE STATED		FINISH, UNLESS OTHERWISE STATED:	
				DWG NO. 9240040-910
				ISSUE 3
				SHEET 1 / 2
ROSEMOUNT		1 ST ANGLE	SCALE	The copyright/ownership of this document is and will remain ours. The document must not be used without our authorization or brought to the knowledge of a third party. Contravention will be prosecuted. Rosemount Tank Radar AB, Sweden

ISSUE	CHANGE ORDER No	WEEK	ISSUE	CHANGE ORDER No	WEEK	ISSUE	CHANGE ORDER No	WEEK
1	SME-6097	1012	2	SME-7153	1141	3	SME-7572	1351

HAZARDOUS LOCATION

HAZARDOUS OR NON-HAZARDOUS LOCATION

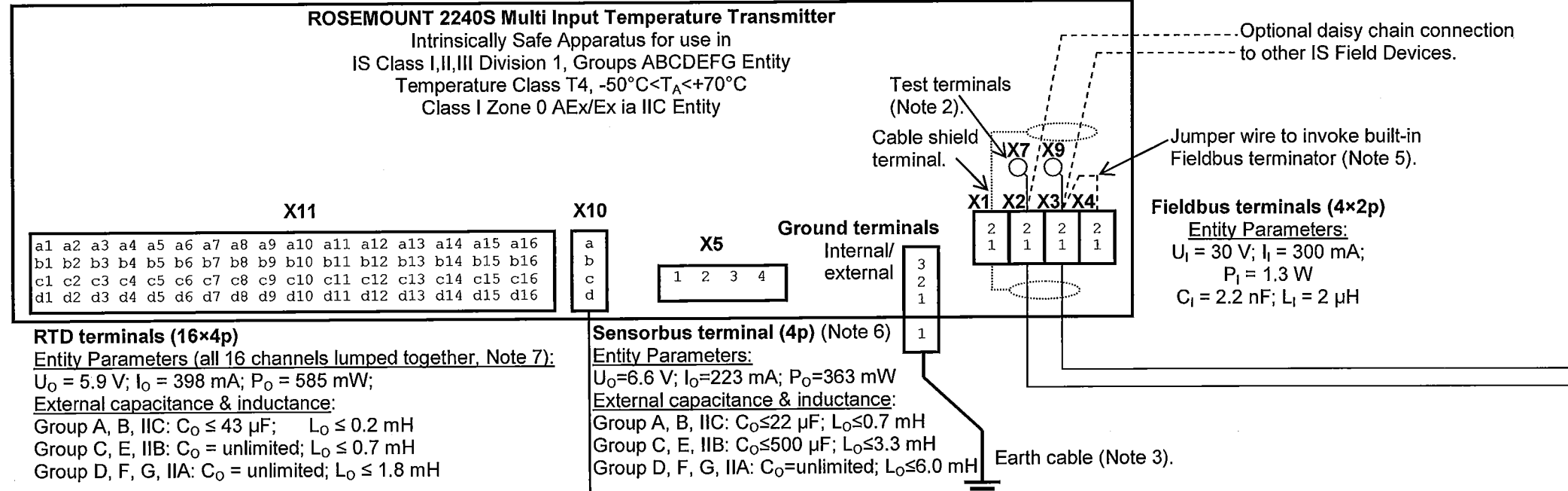

Intrinsically Safe power supply
 (Associated Apparatus, Note 1.)

Entity Parameters:
 $U_o \leq 30\text{ V}; I_o \leq 300\text{ mA}; P_o \leq 1.3\text{ W}$
 $C_o \geq \text{Total capacitance of connected cables and Fieldbus Devices.}$
 $L_o \geq \text{Total inductance of connected cables and Fieldbus Devices.}$

RTD terminals (16x4p)
 Entity Parameters (all 16 channels lumped together, Note 7):
 $U_o = 5.9\text{ V}; I_o = 398\text{ mA}; P_o = 585\text{ mW};$
 External capacitance & inductance:
 Group A, B, IIC: $C_o \leq 43\text{ }\mu\text{F}; L_o \leq 0.2\text{ mH}$
 Group C, E, IIB: $C_o = \text{unlimited}; L_o \leq 0.7\text{ mH}$
 Group D, F, G, IIA: $C_o = \text{unlimited}; L_o \leq 1.8\text{ mH}$

Test terminal (4p)
 Simple Apparatus
 (Resistors replacing an RTD if connected to any one of the RTD input channels.)

Alternative RTD connection schemes

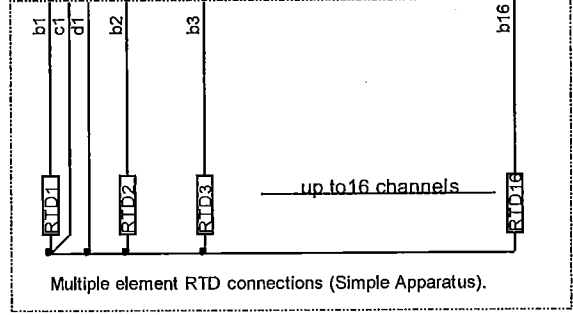
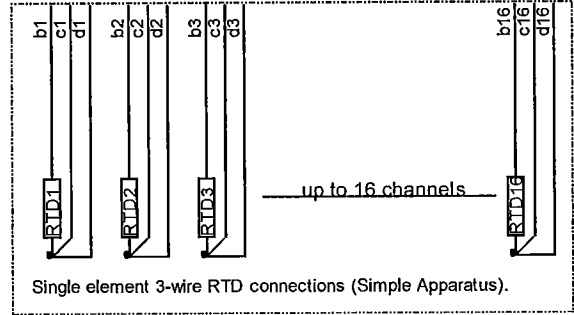
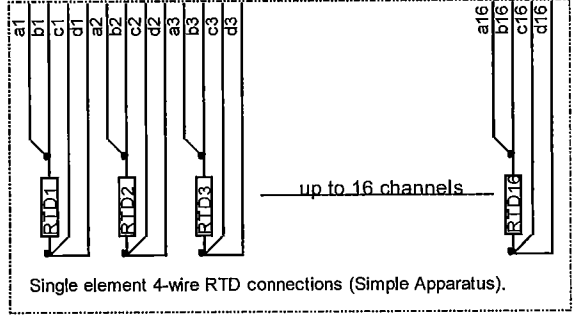

- Notes:
- Control equipment connected to the Associated Apparatus must not use or generate more than 250 V_{RMS} or V_{DC}.
 - Test terminals for temporary connection of Intrinsically Safe Rosemount 375 or 475 Field Communicator.
 - Earth connection cable area: min. 4 mm².
 - Installation in the USA should be in accordance with ANSI/ISA-RP12.6 "Installation of Intrinsically Safe Systems for Hazardous (Classified) Locations" and the National Electrical Code (ANSI/NFPA 70).
Dust tight conduit seals must be used when installed in Class II and Class III environments.
 - It is possible to disconnect the integrated termination by removing the jumper wire in X3:2-X4:2.
 - The Sensorbus terminal is a separate IS circuit and connection of external sensors must be made through a separate shielded cable with the shield connected to one of the Internal Ground terminals.
 - Alternative entity parameters applicable to the RTD terminals (X11) when nothing is connected to the Sensorbus terminal (X5): $U_o = 5.9\text{ V}; I_o = 100\text{ mA}; P_o = 150\text{ mW}; C_o = 43\text{ }\mu\text{F}; L_o = 3.0\text{ mH}$

WARNING: To prevent ignition of flammable or combustible atmospheres, read, understand and adhere to the manufacturer's live maintenance procedures.
WARNING: Substitution of components may impair Intrinsic Safety.

FM APPROVED PRODUCT
 No revision to this drawing without prior Factory Mutual approval

ENTITY CONCEPT APPROVAL

The Entity concept allows interconnection of intrinsically safe apparatus to associated apparatus not specifically examined in combination as a system. The approved values of max. open circuit voltage (U_o, V_{OC} or V_i), max. short circuit current (I_o, I_{SC} or I_i) and max. power (P_o or $V_{OC} \times I_{OC} / 4$ or $V_i \times I_i / 4$), for the associated apparatus must be less than or equal to the maximum safe input voltage (U_i or V_{MAX}), maximum safe input current (I_i or I_{MAX}) and maximum safe input power (P_i or P_{MAX}) of the intrinsically safe apparatus. In addition, the approved max. allowable connected capacitance (C_o or C_a) of the associated apparatus must be greater than the sum of the interconnecting cable capacitance and the unprotected internal capacitance (C_i) of the intrinsically safe apparatus, and the approved max. allowable connected inductance (L_o or L_a) of the associated apparatus must be greater than the sum of the interconnecting cable inductance and the unprotected internal inductance (L_i) of the intrinsically safe apparatus.

9240040-910	ISSUED BY EE-RJ	WEEK 1012	PRODUCT CODE 2240	TITLE SYSTEM CONTROL DWG
	APPROVED BY EAp	WEEK 1012	DOC. TYPE 6	FILE
	ALL DIMENSIONS ARE IN MILLIMETRES. TOLERANCES, UNLESS OTHERWISE STATED:			FINISH, UNLESS OTHERWISE STATED:
	ROSEMOUNT			1 ST ANGLE
DWG NO. 9240040-910				ISSUE 3
SHEET 2 / 2				SCALE
The copyright/ownership of this document is and will remain ours. The document must not be used without our authorization or brought to the knowledge of a third party. Contravention will be prosecuted. Rosemount Tank Radar AB, Sweden				