

1

2

3

4

REVISION HISTORY

REV	DESCRIPTION	DRAWN	CHECKED	APPROVED	DATE
B	REVISED PER ECO 6003729	S. BLACK	J. PRATT	S. BLACK	2/13/2013
C	REVISED PER ECO# 6003785.	J. PRATT	N. PHAM	J. PRATT	1/24/2014

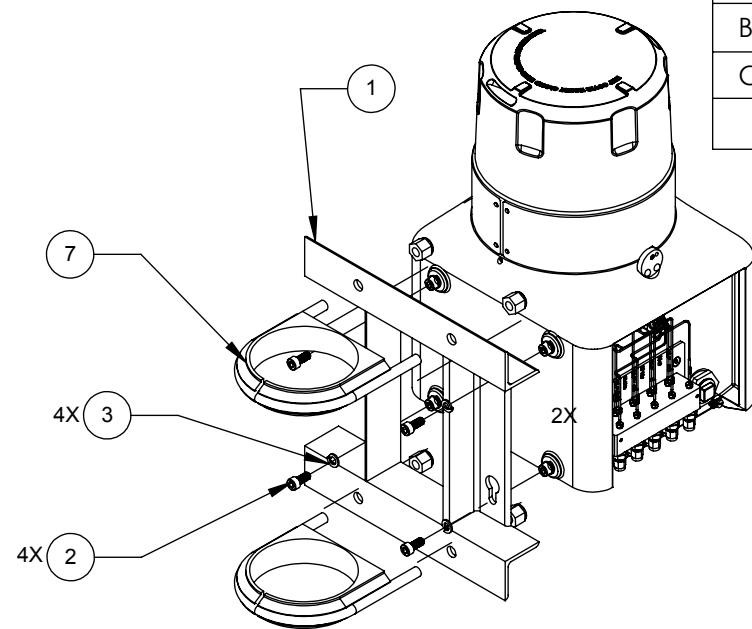
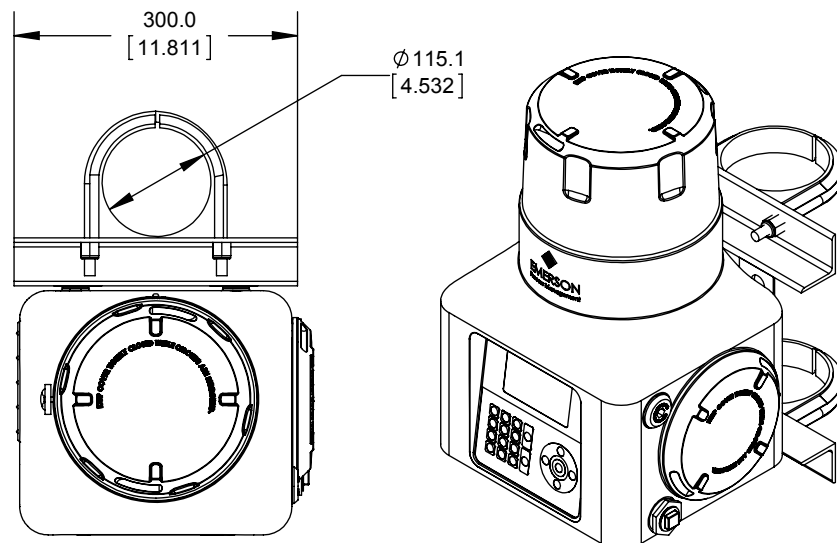

2	-	5	2	7	7C00055-004	PIPE CLAMP, 4", U-BOLT ASSEMBLY	EA
-	-	1	-	6	7P00179H01	CALIBRATION GAS BOTTLE CRADLE SUB ASSY	EA
-	-	2	-	5	7P00178H01	CARRIER GAS BOTTLE CRADLE/RESTRAINT SUB ASSY	EA
-	-	1	1	4	7A00043G01	STAND, FLOOR MOUNT, 370XA	EA
4	4	4	4	3	7C00009-008	WASHER, SPRING LOCK, M8, DIN 127B, SST	EA
4	4	4	4	2	7C00008-018	SHCS, M8 X 1.25 X 18 MM, SST, DIN 912-A2	EA
1	1	1	1	1	7P00176H01	370XA PIPE/WALL MOUNT FRAME	EA
			X		7A00013G04	KIT, FLOOR MOUNT, 370XA	EA
		X			7A00013G03	KIT, FLOOR MOUNT W/BOTTLE RACKS, 370XA	EA
	X				7A00013G02	KIT, WALL MOUNT, 370XA	EA
X					7A00013G01	KIT, PIPE MOUNT, 370XA	EA

G01 QTY	G02 QTY	G03 QTY	G04 QTY	ITEM NO.	PART NUMBER	DESCRIPTION	UNITS
---------	---------	---------	---------	----------	-------------	-------------	-------

PARTS LIST

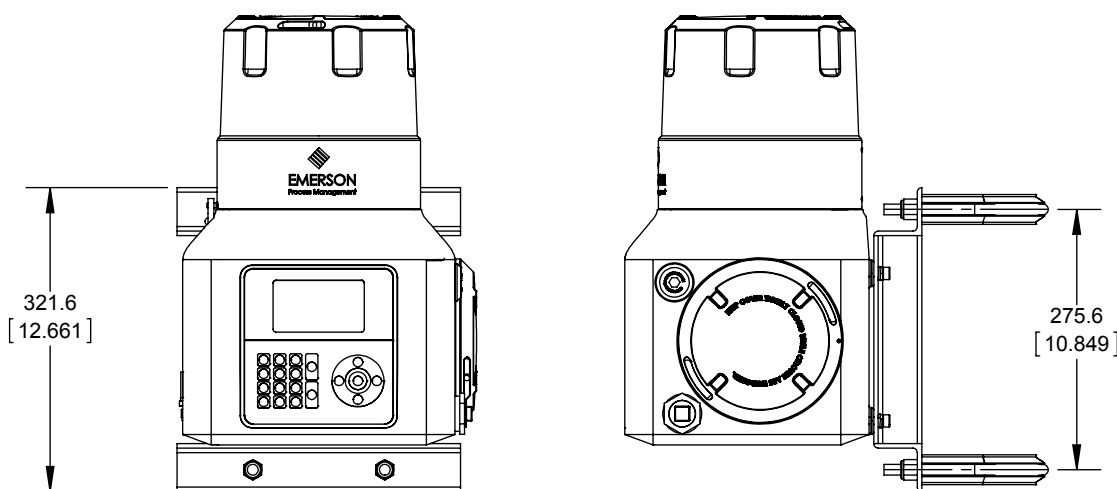

PART NO. 7A00013G01

METRIC
THIRD ANGLE PROJECTION

GEOMETRIC TOLERANCES & DIMENSIONS PER ANSI Y14.5 LATEST REVISION
UNLESS OTHERWISE SPECIFIED ALL DIMENSIONS ARE IN mm [in].

X. ± 1.0 mm [.040 in]
X.X ± .25 mm [.010 in]
X.XX ± .10 mm [.004 in]
ANGULAR ± .5°

FINISH: N/A
MATERIAL: AS NOTED

BREAK ALL SHARP CORNERS TO .10-.40 mm [.004-.016 in] RADIUS AND REMOVE ALL BURRS

EMERSON
Process Management

DRN	S. BLACK	DATE	1/21/2013
CHKD	J. PRATT	DATE	1/28/2013
ENG	S. BLACK	DATE	2/13/2013

CONFIDENTIAL: This document, including the information it bears, is the property of Rosemount Analytical, Inc. and must be held in strict confidence and properly safeguarded by the recipient at all times. It may not be copied or reproduced, or provided or revealed to any other party, except with the prior written authorization of Rosemount Analytical, Inc., and any authorized copy or reproduction must include this legend. The recipient may use the same only for the purpose for which Rosemount Analytical, Inc. has provided it to the recipient, and it must be returned to Rosemount Analytical, Inc., along with all copies and reproductions, upon request. By accepting this document, the recipient agrees to the foregoing.

TITLE 370XA MOUNTING OPTIONS

SIZE	B	DWG NO.	7A00013	REV	C
SCALE	1:20	SHT	1 OF 4		

1

2

3

4

1

2

3

4

D

D

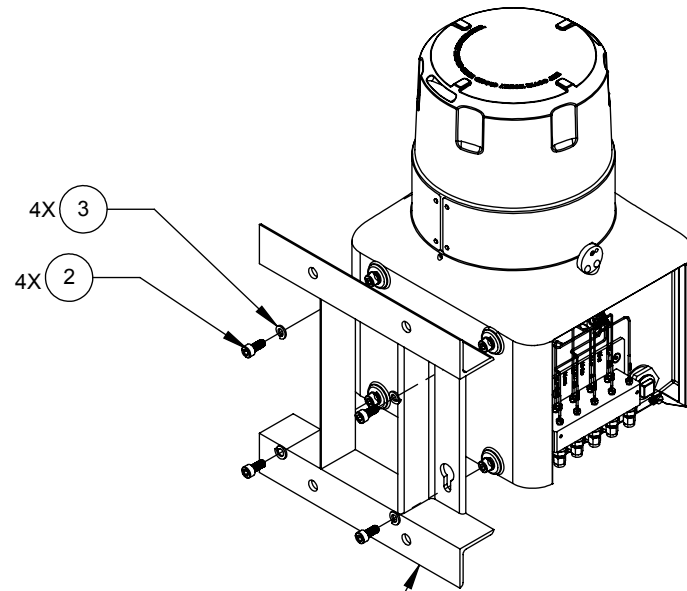
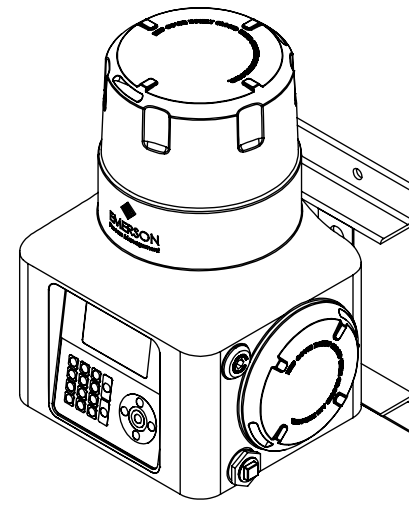
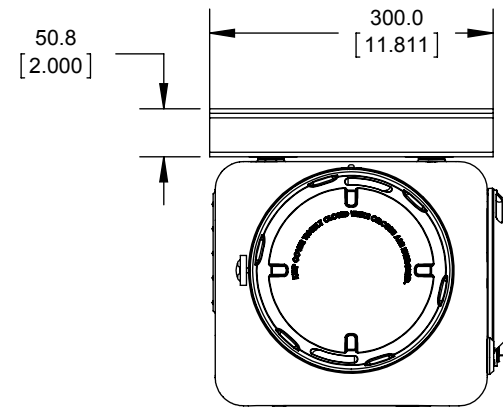

C

C

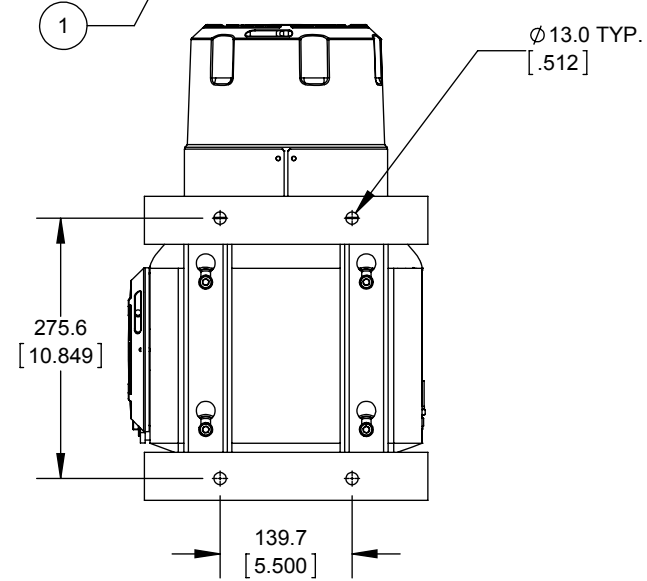
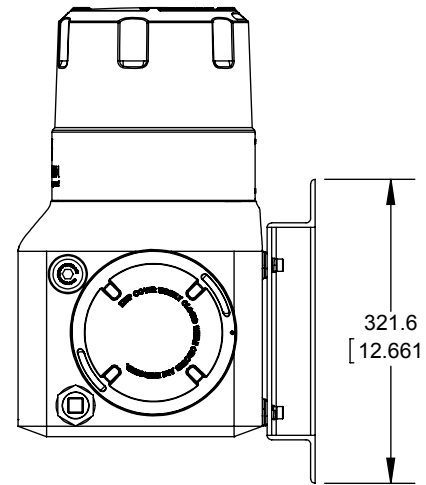
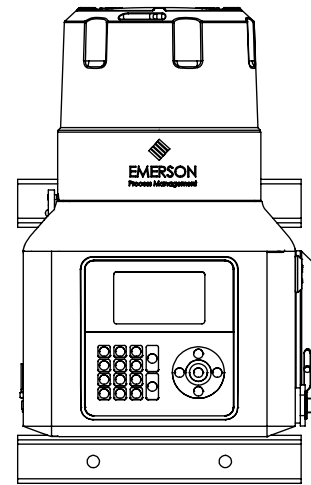

B

B

A

A

PART NO. 7A00013G02

SIZE B	DWG NO.	7A00013	REV C
SCALE 1:20	SHT 2 OF 4		

1

2

3

4

1

2

3

4

D

D

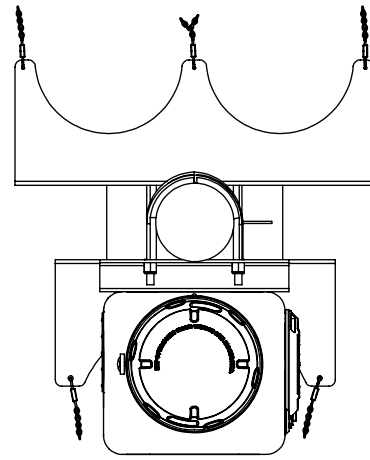

R193.0
[7.600]

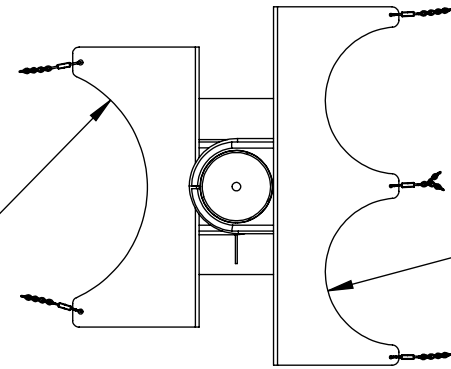

R116.8
[4.600]

SECTION A-A

C

C

569.0
[22.400]

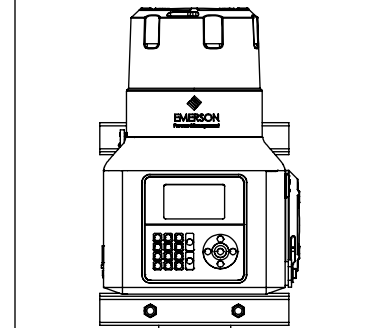

B

B

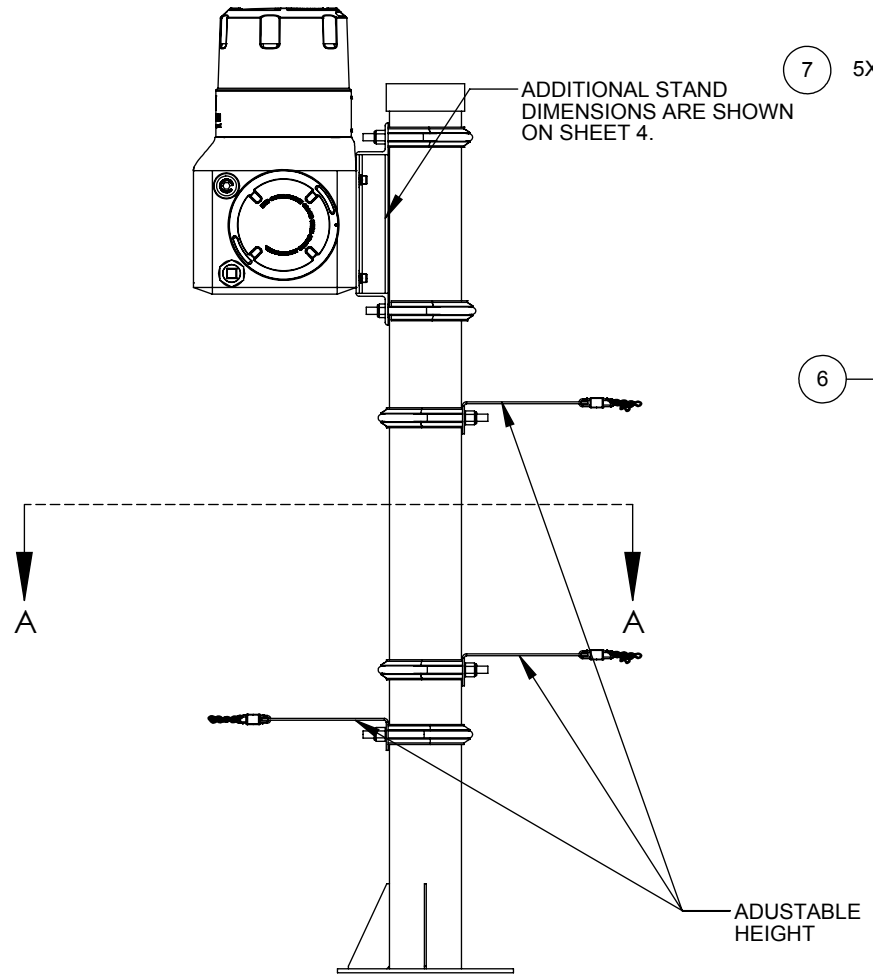

7 5X

6

4

5 2X

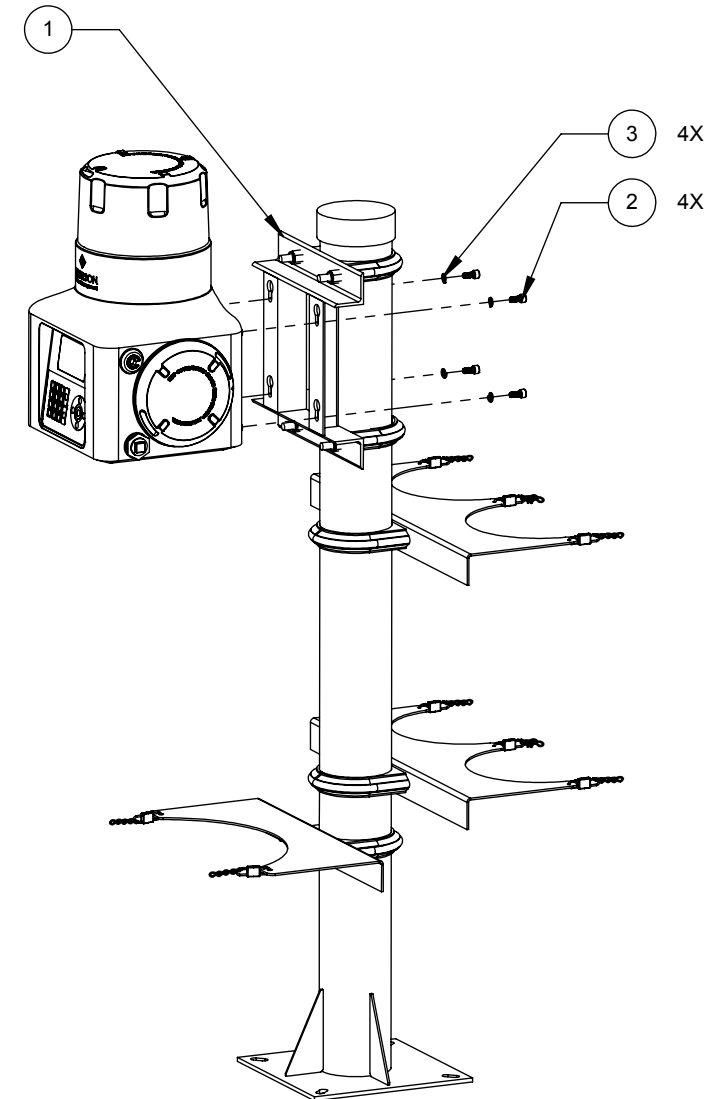

3 4X

2 4X

A

A

PART NO. 7A00013G03

SIZE B	DWG NO.	7A00013	REV C
SCALE 1:20	SHT 3 OF 4		

1

2

3

4

1

2

3

4

D

D

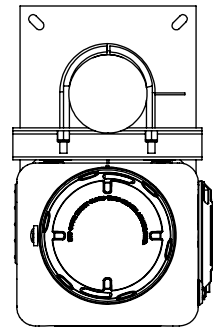

C

C

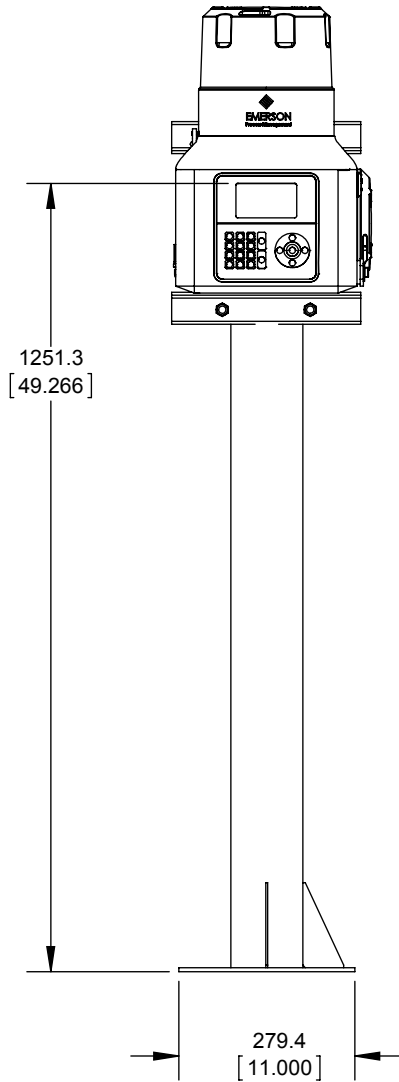

B

B

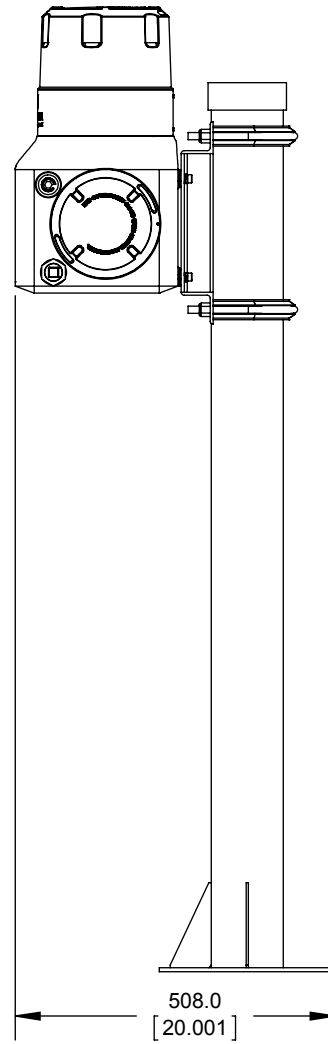

A

A

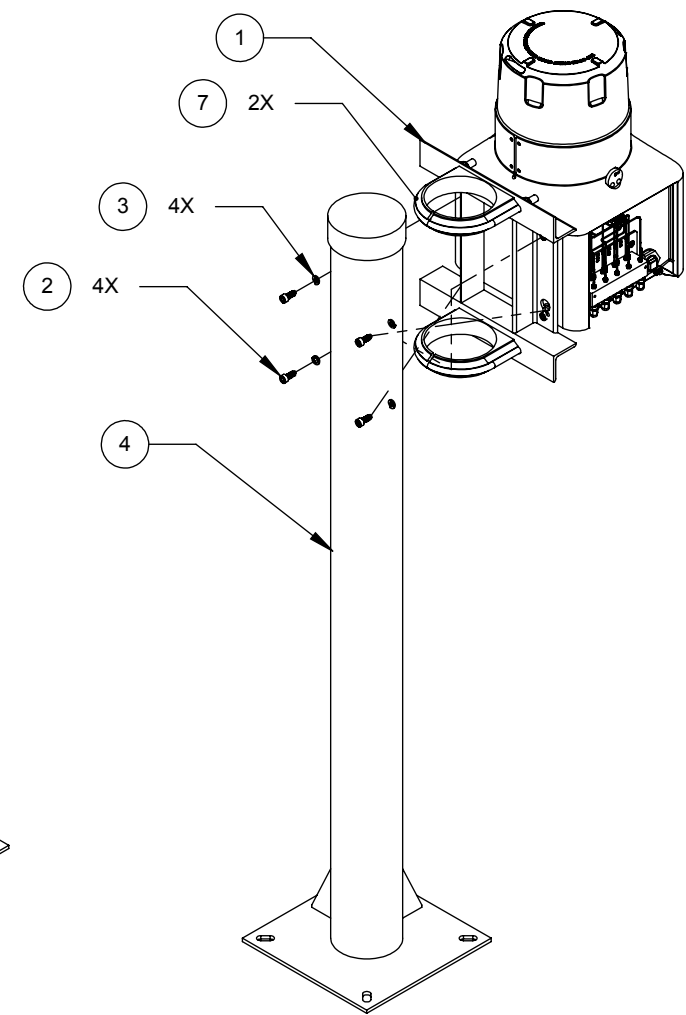
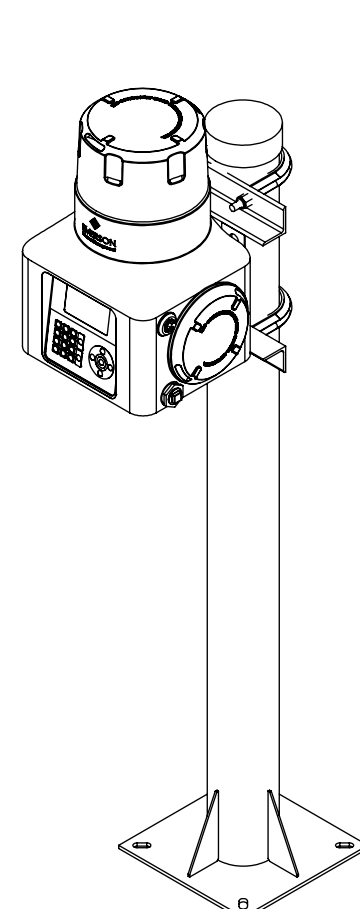

PART NO. 7A00013G04

SIZE B	DWG NO. 7A00013	REV C
SCALE 1:20	SHT 4 OF 4	

1

2

3

4