

# Greif-Drehmodule GMQ/RE

GMQ 12/RE-50 - GMQ 32/RE-75

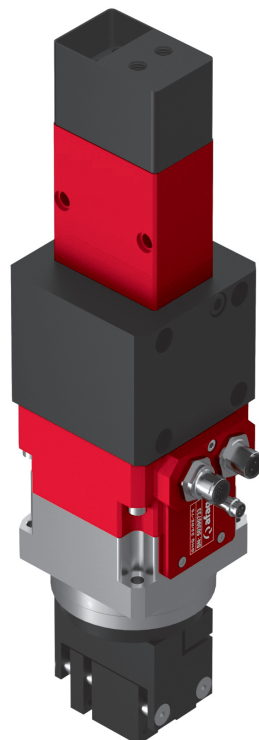
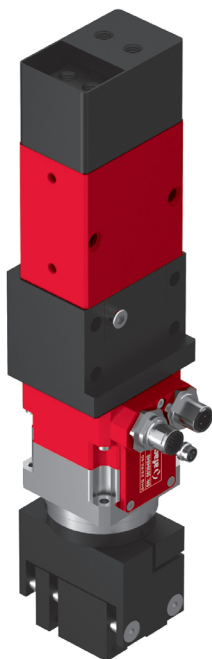
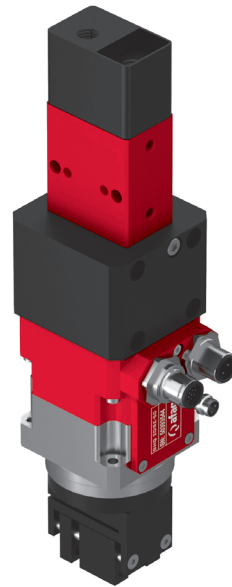
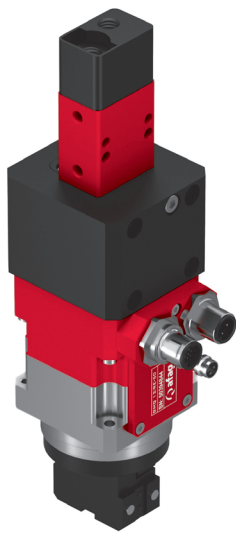

# Inhaltsverzeichnis GMQ/RE

<b>Greif-Drehmodule GMQ/RE</b>	<b>Seite</b>
GMQ 12/RE-50	285
GMQ 20/RE-50	289
GMQ 32/RE-50	293
GMQ 32/RE-75	297

GMQ 12/P /RE-50	Greif-Drehmodul	Mögliche Werte
GMQ	Greifantrieb	GMQ
12	Kolbendurchmesser Greifantrieb	12
		20
		32
P	Greifzange	../K
		../P
		../P-01
RE	Rotationsmodul	RE
		RE..18-100 V
50	Baugröße Rotationsmodul	50
		75

Das Greif-Drehmodul besteht aus den Afag-Standardmodulen:

- Greifantrieb GMQ 12
- Rotationsmodul RE-50
- Greifzange GM 12/P

### Legende

- |   |   |
|---|---|
| A | RE Rotationsmodul: Es sind 4 Positionen zu je 90° möglich |
| B | GMQ Greifantrieb: Ist stufenlos drehbar um 360°           |

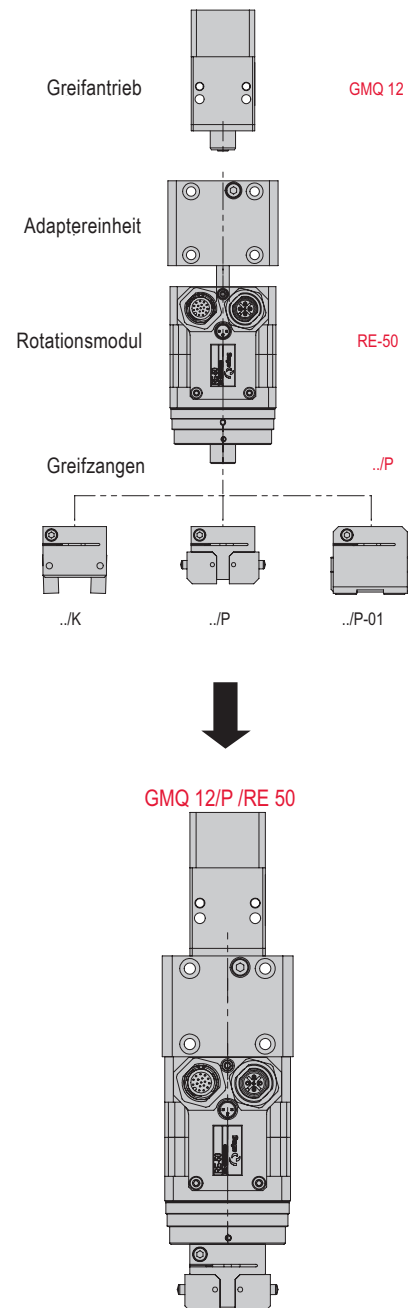
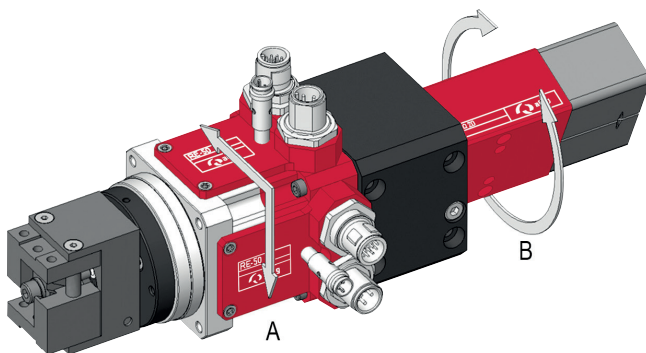

Der gewünschte Greifantrieb wird über eine Adaptereinheit hinter dem Rotationsmodul angebaut. Dadurch drehen bei einer Drehbewegung keine Pneumatik- und Elektrik-Anschlüsse mit.

Die Greifzangen werden vorne an das gewünschte Rotationsmodul aus dem breiten Afag-Sortiment angebaut. Dies erlaubt eine Drehbewegung der Greifzangen.

Die kompakte Bauform der Greif-/Drehmodule weist nahezu keine Störkonturen auf.

# Greif-Drehmodule GMQ/RE

## GMQ 12/RE-50

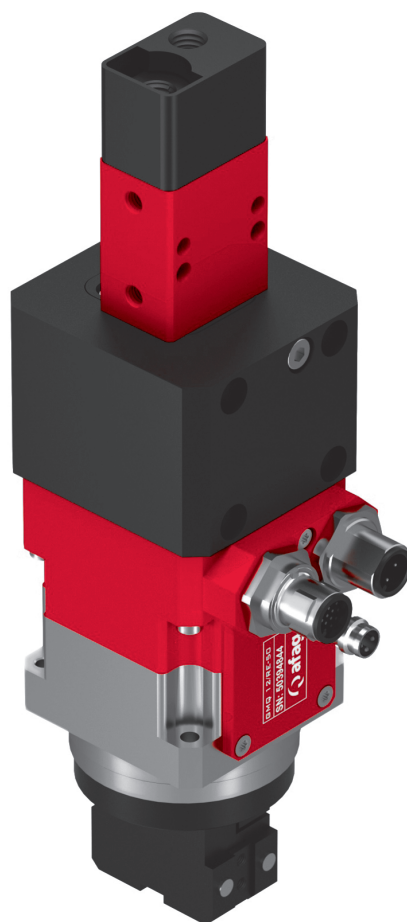

15

- Modulare Kombinationen
- Keine bewegten Schläuche und Kabel
- Zangen können in beliebige Position gedreht werden

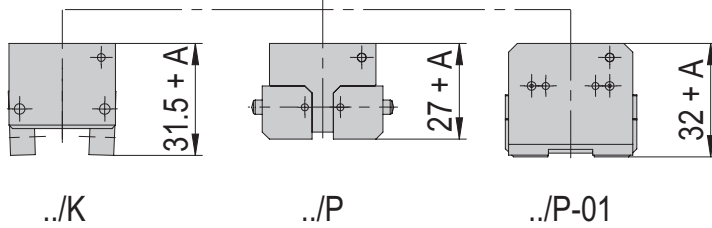
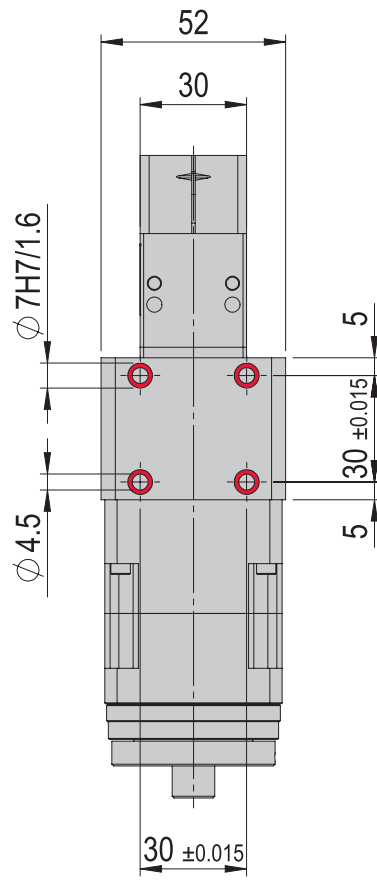
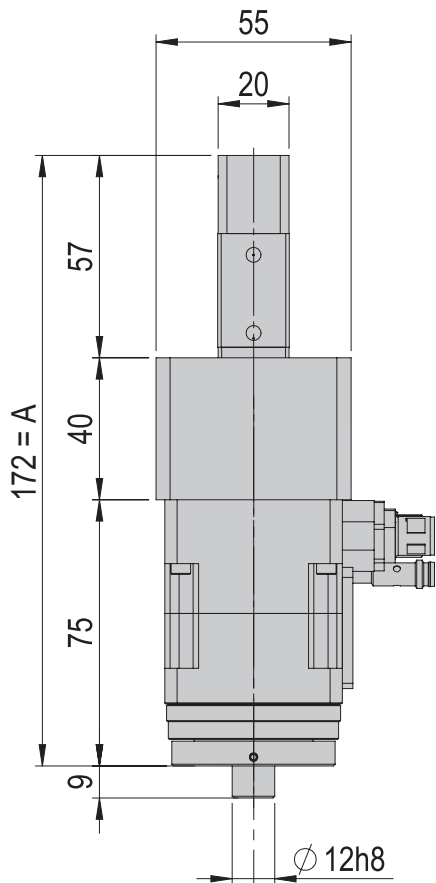
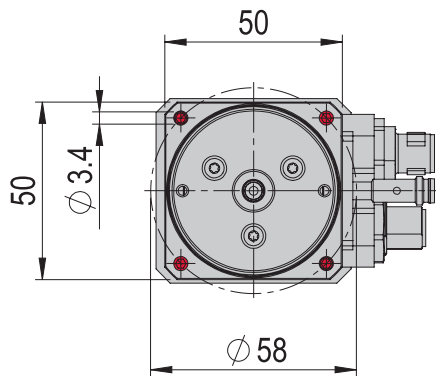

 Bohrungen sind durchschraubbar



GMQ 12/RE-50

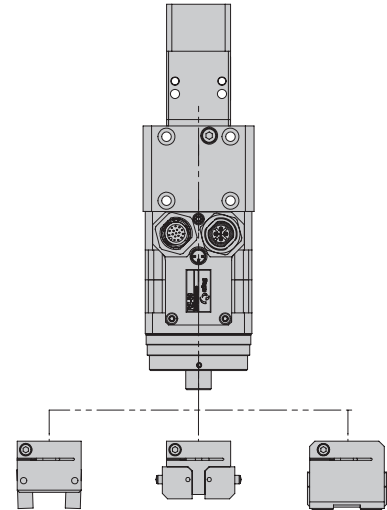

Zangen	..K	..P	..P-01
<b>GMQ 12/./RE-50 18-100V</b>	<b>50395566</b>	<b>50395567</b>	<b>50395569</b>
Nettogewicht	0.974 kg	1.044 kg	1.07 kg
<b>GMQ 12/./RE-50</b>	<b>50394843</b>	<b>50394844</b>	<b>50394846</b>
Nettogewicht	0.974 kg	1.044 kg	1.07 kg

### Im Lieferumfang inbegriffen

(Katalog HT Zubehör)

- 2x Zentrierhülse Ø7x3



ES-20	1,3	< direct >	1
ES-30	1 3	< direct > VP 112	2 2
ES-40	1,3	direct	1
ES40-HP	1,3	direct	1
SA-3	1,2	< direct >	1
SA-6	1,2	< direct >	1
PEZ-52	3	VP 117	2
PEZ-65	3	< direct >	1
PEZ-80	3	VP 112	1
PEL-20	3	direct	1
PDL-30	3	direct	1
PDL-40	3	direct	1
CS 16	1,3	< direct >	1
CS 20	1,3	VP 112	1
CS 25	1,3	VP 112	1
HM 16	1	< direct >	1
HM 25	1	VP 112	1
PMP-c	1,3	VP 120	1

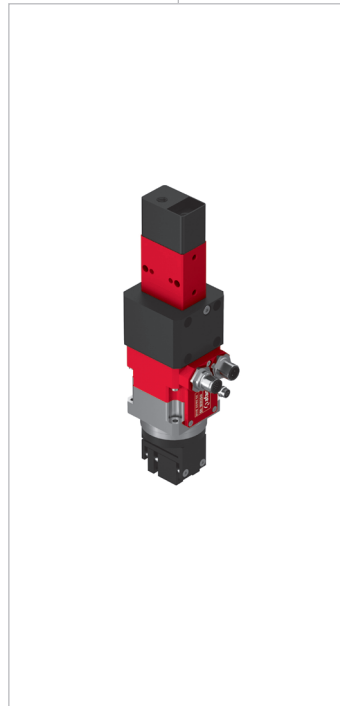

↑ ↑  
**Anbauflächen**

CS, ES	LM	HM	SA	UG, GM, SG, DG, PG, GE, SGE
PMP, PMP-c	PEZ, PDZ	PEL, PDL	RM, RE	CR, RM 32, RE, SREH, RA

Beachten Sie die möglichen Anbaulagen der Module zueinander.

Erforderliche Verbindungselemente und das Ständerprogramm finden Sie in den Kapiteln «Verbindungselemente» und «Ständerprogramm».

# Greif-Drehmodule GMQ/RE

## GMQ 20/RE-50

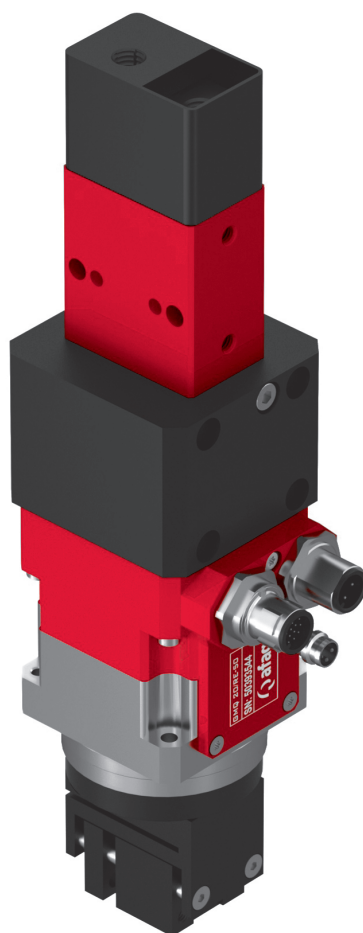

- Modulare Kombinationen
- Keine bewegten Schläuche und Kabel
- Zangen können in beliebige Position gedreht werden



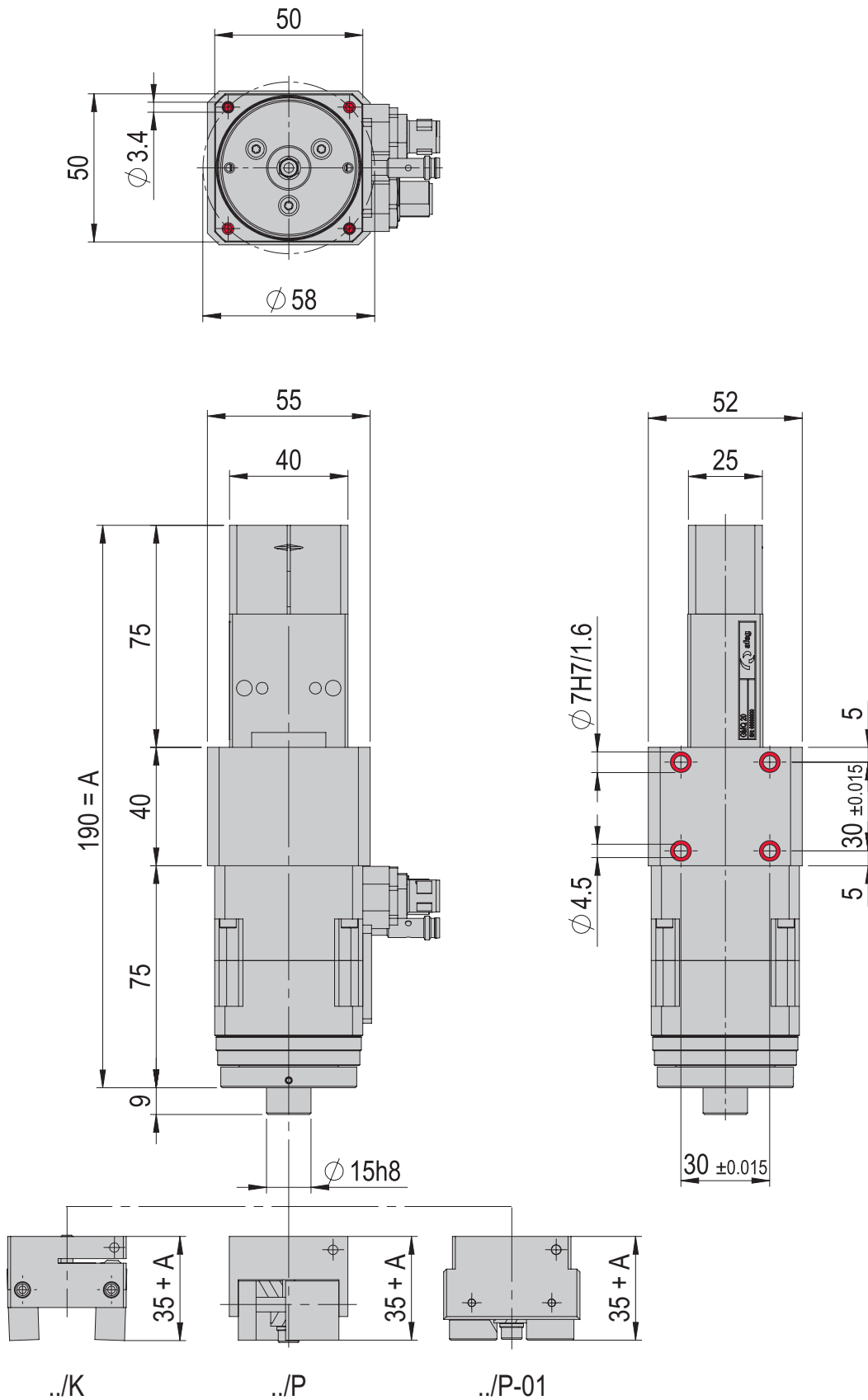

 Bohrungen sind durchschraubbar



GMQ 20/RE-50

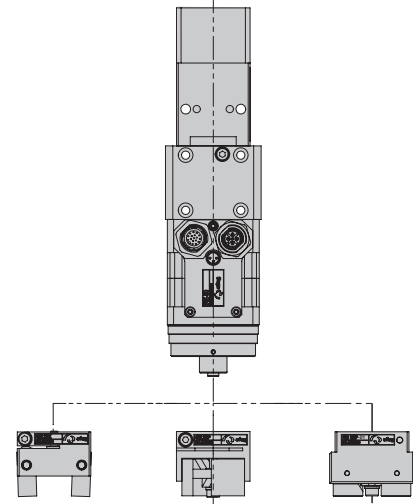

Zangen	..K	..P	..P-01
<b>GMQ 20/./RE-50 18-100V</b>	<b>50355549</b>	<b>50355547</b>	<b>50410327</b>
Nettogewicht	1.141 kg	1.148 kg	1.194 kg
<b>GMQ 20/./RE-50</b>	<b>50355546</b>	<b>50355544</b>	<b>50410326</b>
Nettogewicht	1.141 kg	1.148 kg	1.194 kg

### Im Lieferumfang inbegriffen

(Katalog HT Zubehör)

- 2x Zentrierhülse Ø7x3



ES-20	1,3	< direct >	1
ES-30	1 3	< direct > VP 112	2 2
ES-40	1,3	direct	1
ES40-HP	1,3	direct	1
SA-3	1,2	< direct >	1
SA-6	1,2	< direct >	1
PEZ-52	3	VP 117	2
PEZ-65	3	< direct >	1
PEZ-80	3	VP 112	1
PEL-20	3	direct	1
PDL-30	3	direct	1
PDL-40	3	direct	1
CS 16	1,3	< direct >	1
CS 20	1,3	VP 112	1
CS 25	1,3	VP 112	1
HM 16	1	< direct >	1
HM 25	1	VP 112	1
PMP-c	1,3	VP 120	1

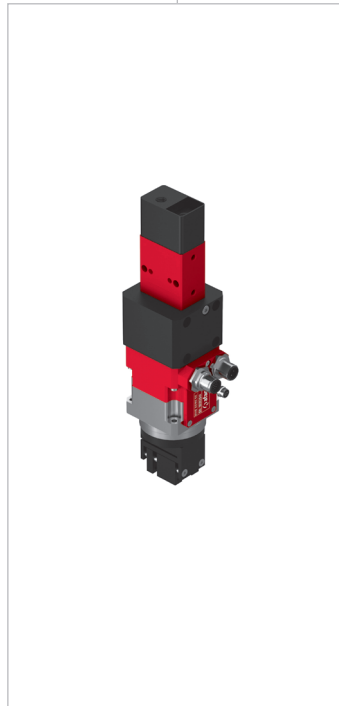

↑ ↑  
**Anbauflächen**

CS, ES	LM	HM	SA	UG, GM, SG, DG, PG, GE, SGE
PMP, PMP-c	PEZ, PDZ	PEL, PDL	RM, RE	CR, RM 32, RE, SREH, RA

Beachten Sie die möglichen Anbaulagen der Module zueinander.

Erforderliche Verbindungselemente und das Ständerprogramm finden Sie in den Kapiteln «Verbindungselemente» und «Ständerprogramm».

# Greif-Drehmodule GMQ/RE

## GMQ 32/RE-50

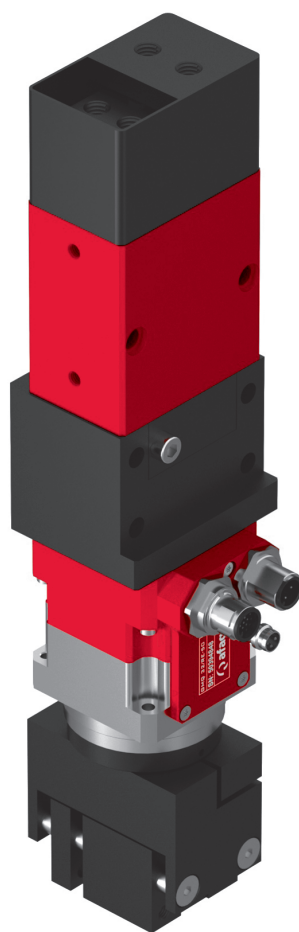

- Modulare Kombinationen
- Keine bewegten Schläuche und Kabel
- Zangen können in beliebige Position gedreht werden

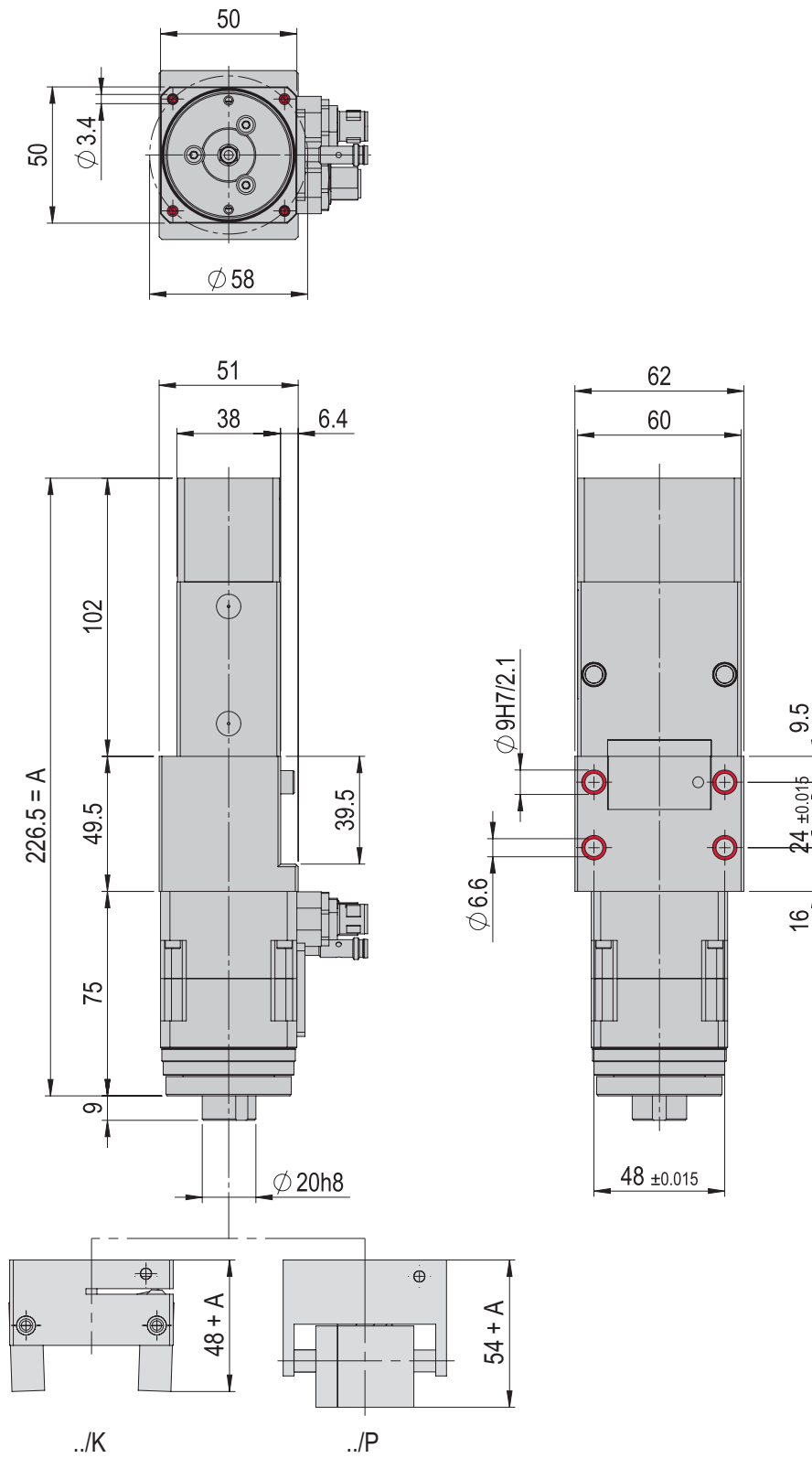

 Bohrungen sind durchschraubbar



GMQ 32/RE-50

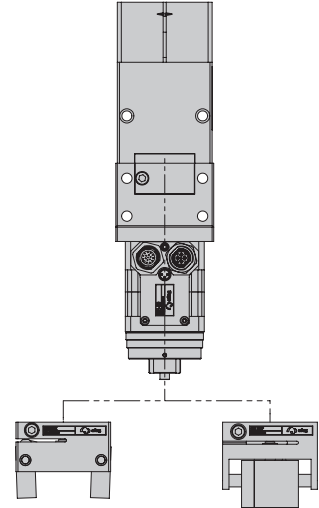

Zangen	..K	..P
<b>GMQ 32/./RE-50</b>	<b>50394847</b>	<b>50394848</b>
Nettogewicht	1.932 kg	2.107 kg
<b>GMQ 32/./RE-50 18-100V</b>	<b>50395570</b>	<b>50395571</b>
Nettogewicht	1.932 kg	2.107 kg

15

### Im Lieferumfang inbegriffen

(Katalog HT Zubehör)

- 2x Zentrierhülse Ø9x4



ES-20	1,3	< direct >	1
ES-30	1 3	< direct > VP 112	2 2
ES-40	1,3	direct	1
ES40-HP	1,3	direct	1
SA-3	1,2	< direct >	1
SA-6	1,2	< direct >	1
PEZ-52	3	VP 117	2
PEZ-65	3	< direct >	1
PEZ-80	3	VP 112	1
PEL-20	3	direct	1
PDL-30	3	direct	1
PDL-40	3	direct	1
CS 16	1,3	< direct >	1
CS 20	1,3	VP 112	1
CS 25	1,3	VP 112	1
HM 16	1	< direct >	1
HM 25	1	VP 112	1
PMP-c	1,3	VP 120	1

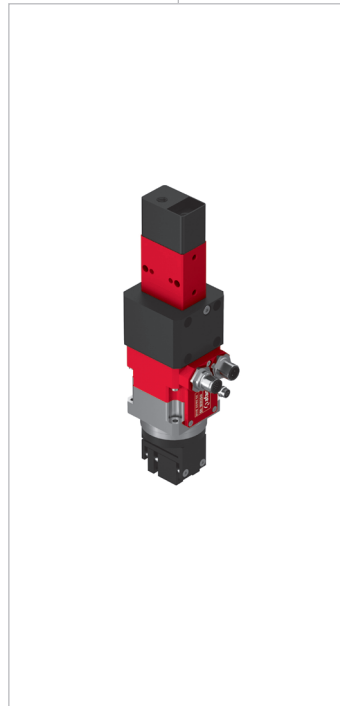

↑ ↑  
**Anbauflächen**

CS, ES	LM	HM	SA	UG, GM, SG, DG, PG, GE, SGE
PMP, PMP-c	PEZ, PDZ	PEL, PDL	RM, RE	CR, RM 32, RE, SREH, RA

Beachten Sie die möglichen Anbaulagen der Module zueinander.

Erforderliche Verbindungselemente und das Ständerprogramm finden Sie in den Kapiteln «Verbindungselemente» und «Ständerprogramm».

# Greif-Drehmodule GMQ/RE

## GMQ 32/RE-75

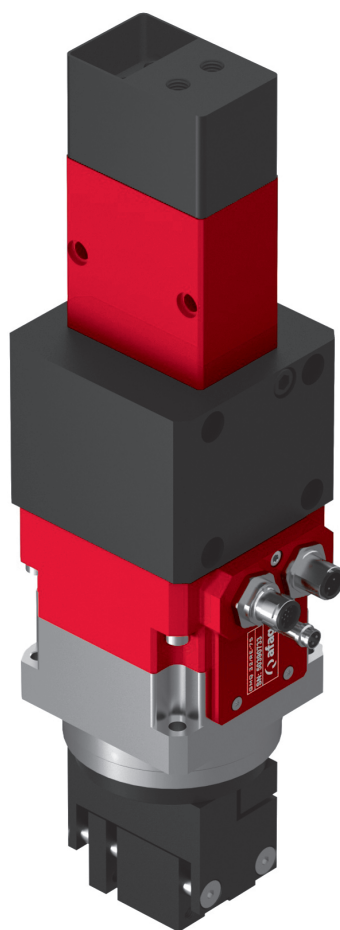

15

- Modulare Kombinationen
- Keine bewegten Schläuche und Kabel
- Zangen können in beliebige Position gedreht werden



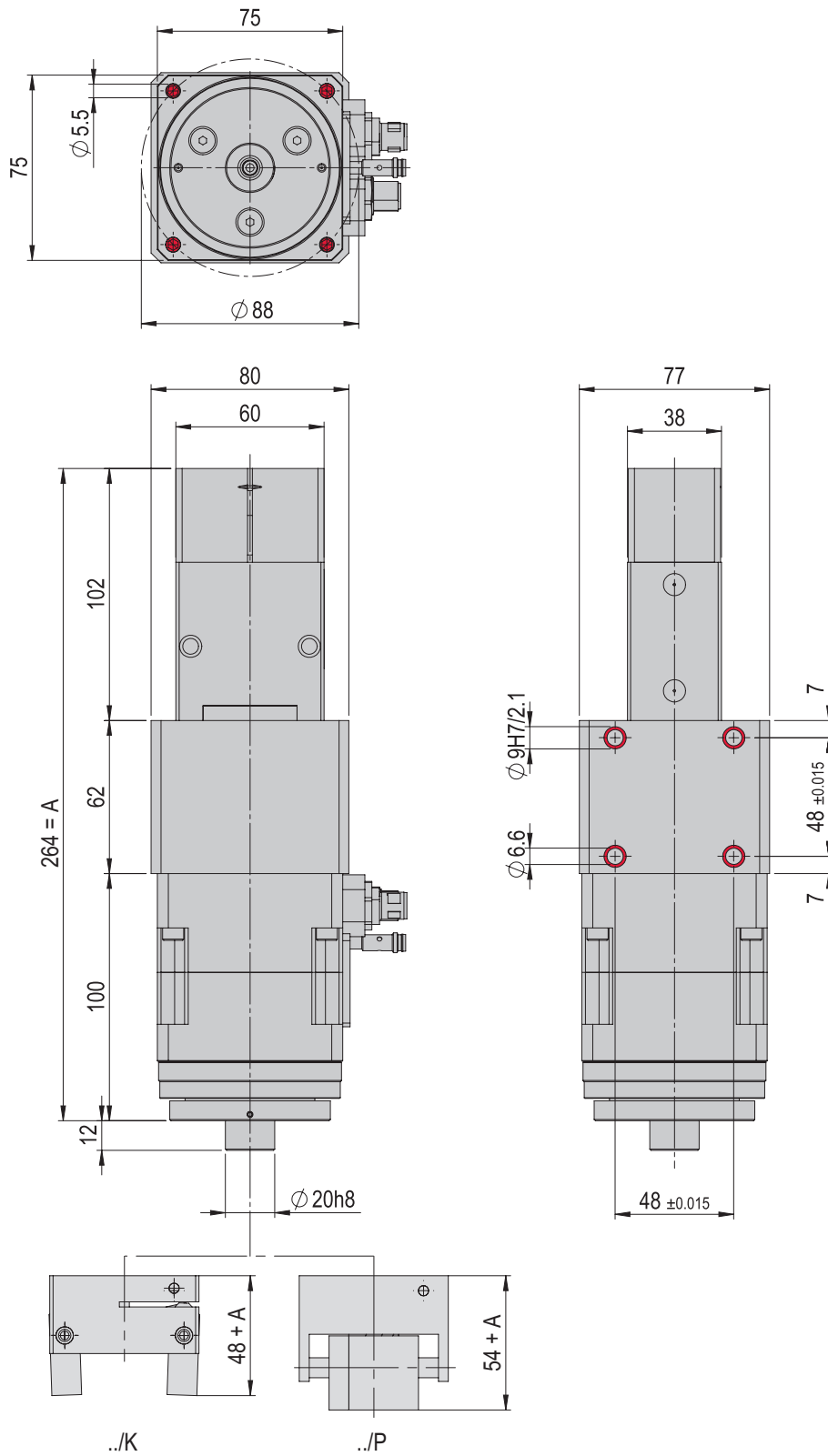

 Bohrungen sind durchschraubbar



GMQ 32/RE-75

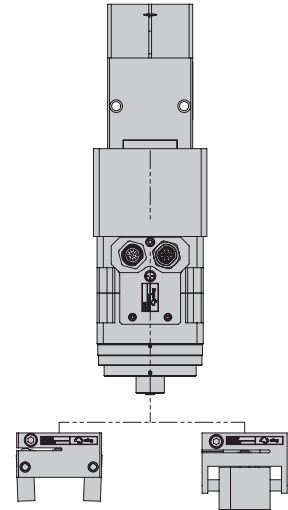

Zangen	..K	..P
<b>GMQ 32/./RE-75</b>	<b>50390735</b>	<b>50390733</b>
Nettogewicht	3.352 kg	3.527 kg
<b>GMQ 32/./RE-75 18-100V A</b>	<b>50545293</b>	<b>50545292</b>
Nettogewicht	3.352 kg	3.527 kg

15

### Im Lieferumfang inbegriffen

(Katalog HT Zubehör)

- 2x Zentrierhülse Ø9x4



ES-20	1,3	< direct >	1
ES-30	1 3	< direct > VP 112	2 2
ES-40	1,3	direct	1
ES40-HP	1,3	direct	1
SA-3	1,2	< direct >	1
SA-6	1,2	< direct >	1
PEZ-52	3	VP 117	2
PEZ-65	3	< direct >	1
PEZ-80	3	VP 112	1
PEL-20	3	direct	1
PDL-30	3	direct	1
PDL-40	3	direct	1
CS 16	1,3	< direct >	1
CS 20	1,3	VP 112	1
CS 25	1,3	VP 112	1
HM 16	1	< direct >	1
HM 25	1	VP 112	1
PMP-c	1,3	VP 120	1

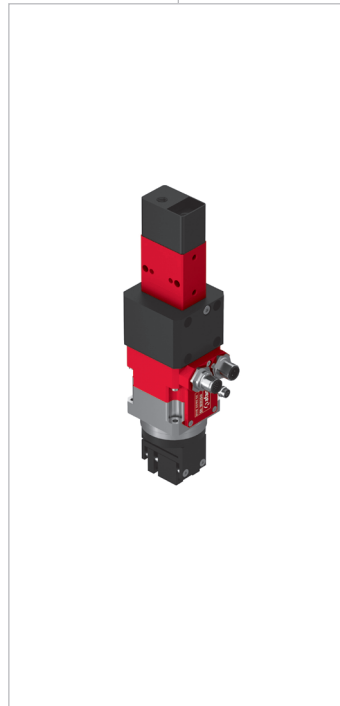

↑ ↑  
**Anbauflächen**

CS, ES	LM	HM	SA	UG, GM, SG, DG, PG, GE, SGE
PMP, PMP-c	PEZ, PDZ	PEL, PDL	RM, RE	CR, RM 32, RE, SREH, RA

Beachten Sie die möglichen Anbaulagen der Module zueinander.

Erforderliche Verbindungselemente und das Ständerprogramm finden Sie in den Kapiteln «Verbindungselemente» und «Ständerprogramm».