

# Compact slides CS

CS 6 - CS 25

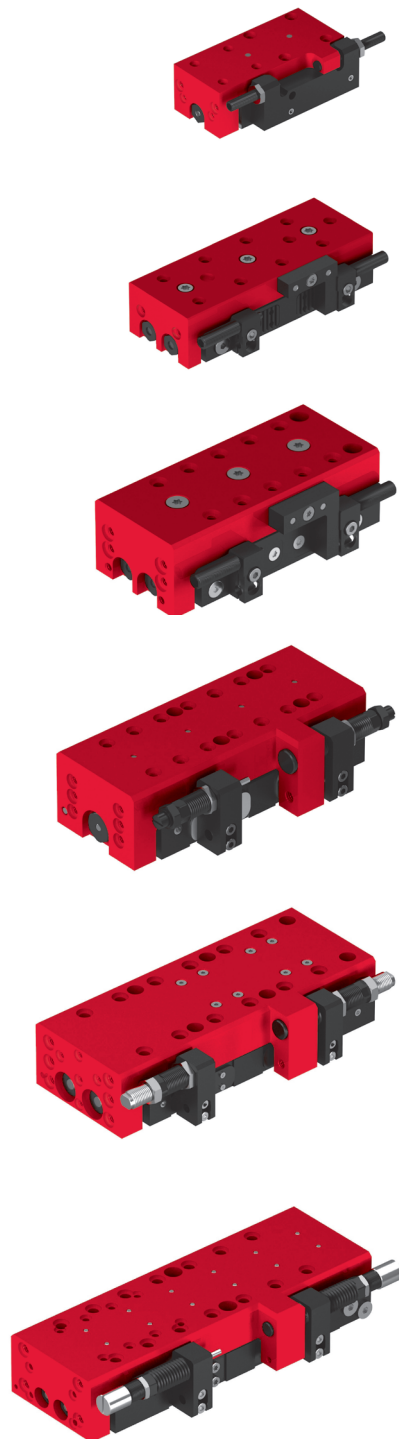

# Table of Contents: CS

<b>Compact slides CS</b>	<b>Page</b>
CS 6	9
CS 8	15
CS 12	23
CS 16	31
CS 20	37
CS 25	43
Accessories CS	49



# Compact slides CS

## CS 6

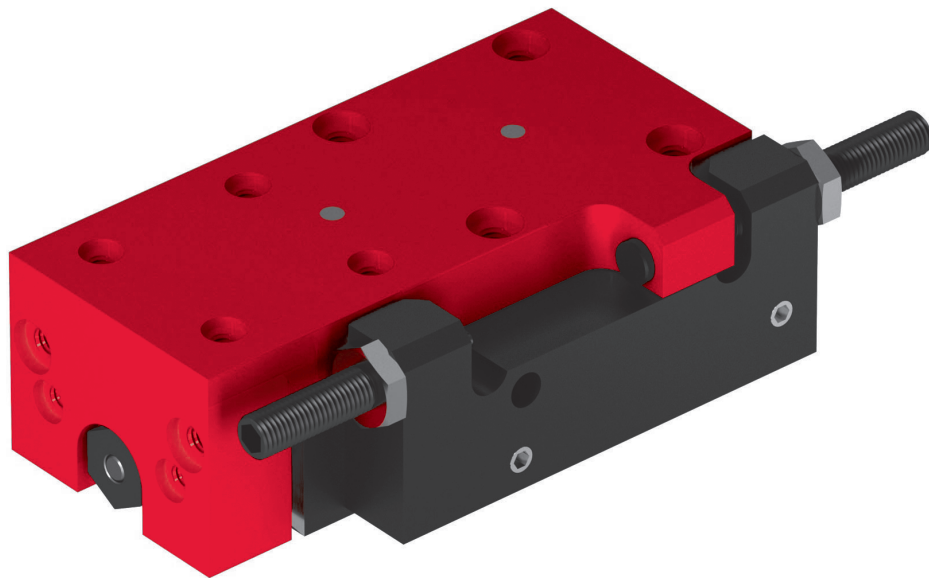

- Compact design
- Solid construction
- High rigidity



Type	CS 6/20-ED	CS 6/40-ED
A	60.5 mm	80.5 mm
B	29 mm	49 mm
C	1 x 20 mm	2 x 20 mm
P	M3	M3

CS 6/40

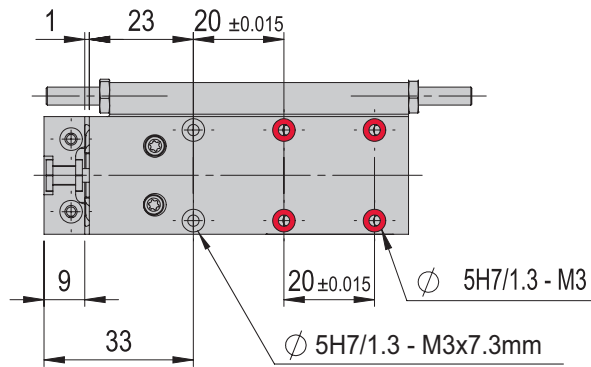

CS 6/20

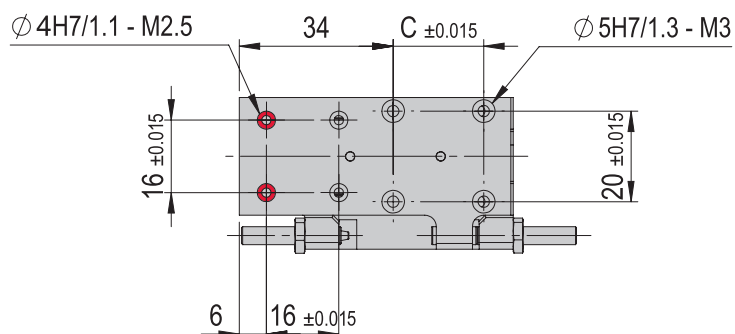
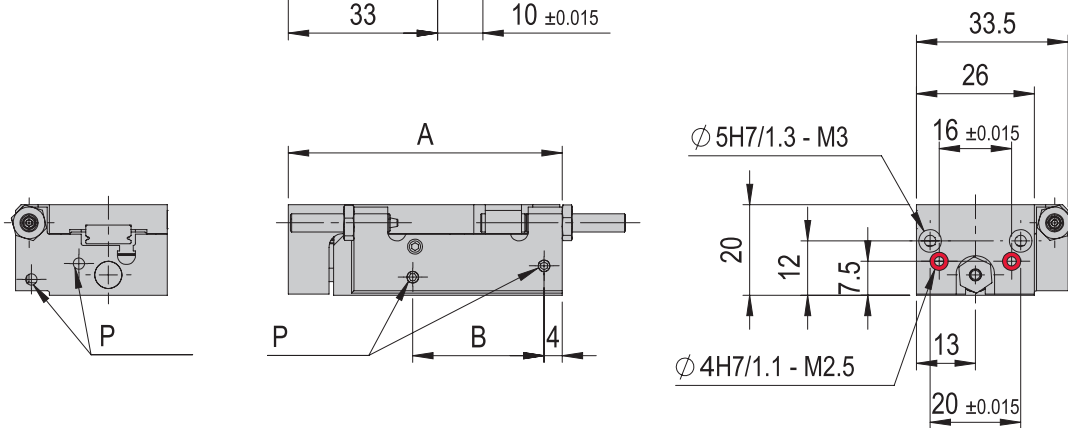
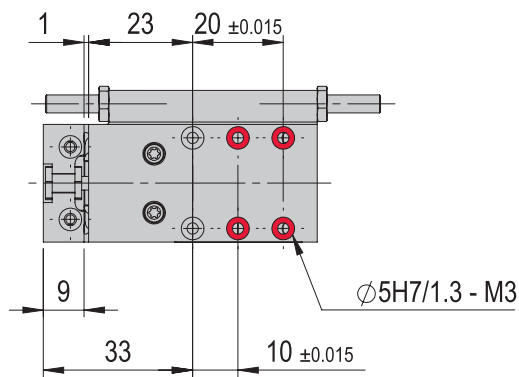

Bores can be screwed through

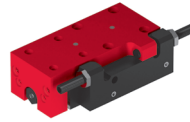

CS 6	
Attachment grid	20 x 20 mm
Attachment grid alternative	16 x 16 mm
Attachment thread	M3
Attachment thread alternative	M2.5
Operating pressure	6 +/- 2 bar
Air connection P	M3
Cylinder Ø	6 mm
Retract piston force	12 N
Extend piston force	17 N
Operating temperature	0 - 50 °C
Storage temperature	0 - 50 °C
Humidity	< 90 %
Medium filtered compressed air	10 - 40 µm

Type	CS 6/20-ED	CS 6/40-ED
<b>Order number</b>	<b>50386049</b>	<b>50386050</b>
Stroke H	20 mm	40 mm
Stroke limitation	2 x 10 mm	2 x 10 mm
Net weight	0.11 kg	0.14 kg
Moving weight	0.05 kg	0.065 kg
Air consumption/cycle	0.005 NL	0.009 NL
Noise level	60 dB (A)	60 dB (A)
Repeat accuracy	+/- 0.01 mm	+/- 0.01 mm
Maximum speed	1 m/s	1 m/s
Minimum speed	0.05 m/s	0.05 m/s
Mounting position	↕	↕

The technical data refers to a nominal pressure of 6 bar under Afag standard test conditions. The maximum payloads are listed in the payloads table in the slide loads section. The module can be operated with lubricated or dry air. Cleanroom class ISO 14644-1, class ISO 7

### Included in the delivery (Catalogue HT accessories)

- 2x Centering bushing Ø5x2.5
- 2x Special screw M3x14.8/4
- 2x Special screw M3 x 16/6
- 2x Shock absorber ASED M4x0.5 -1
- 2x Set screw M3x3

### Accessories

(Catalogue HT accessories)

- INI c10x20-Em-PNP-NO-M8x1

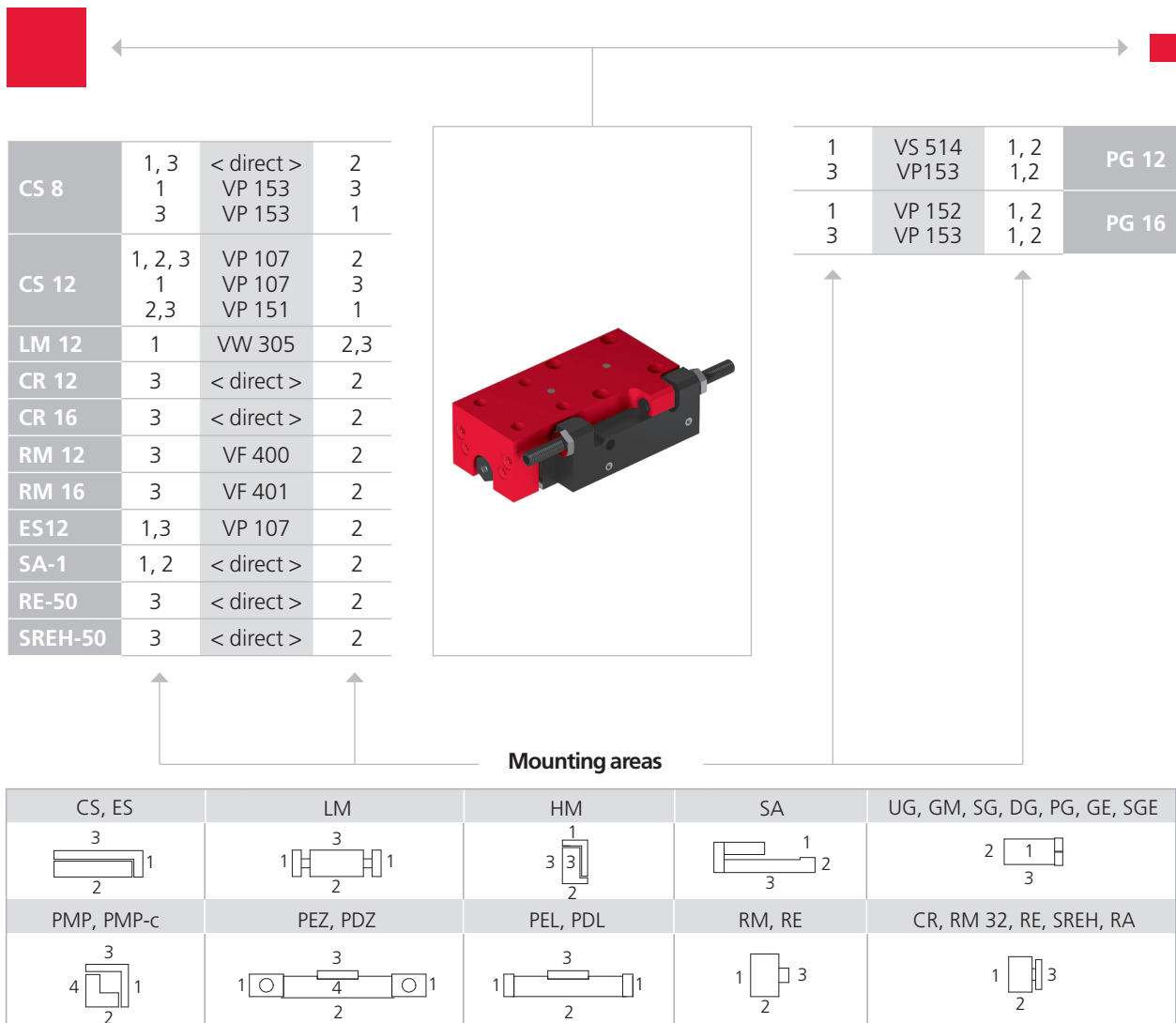

Note that there might be different mounting positions from one module to another one.

The required connection elements and the range of support columns are depicted in the catalogue HT accessories.

Type	CS 6/20-ED	CS 6/40-ED
Max. torque $M_x$	1.9 Nm	1.9 Nm
Max. torque $M_y$	1.3 Nm	1.3 Nm
Max. torque $M_z$	1.3 Nm	1.3 Nm
Effective distance $W_x$	25 mm	25 mm
Effective distance $W_y$	18 mm	18 mm
Effective distance $W_z$	7 mm	7 mm

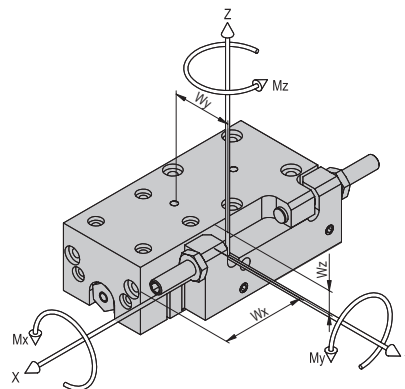

Maximum payload/type	CS 6/20-ED	CS 6/40-ED
Installation position (horizontal) for mounting side 1	0.08 kg	0.08 kg
Installation position (horizontal) for mounting side 3	0.1 kg	0.1 kg
Installation position (vertical) for mounting side 1	0.08 kg	0.08 kg
Installation position (vertical) for mounting side 3	0.1 kg	0.1 kg

Assembly sides  
module mounting

horizontal:

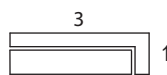

vertical:

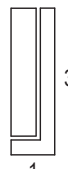

If the specified maximum payloads are exceeded, it must be ensured that the corresponding moments do not affect the service life of the module. All torques are static. In the event of critical applications, please contact Afag.

### Operation time diagrams

CS 6/20-ED

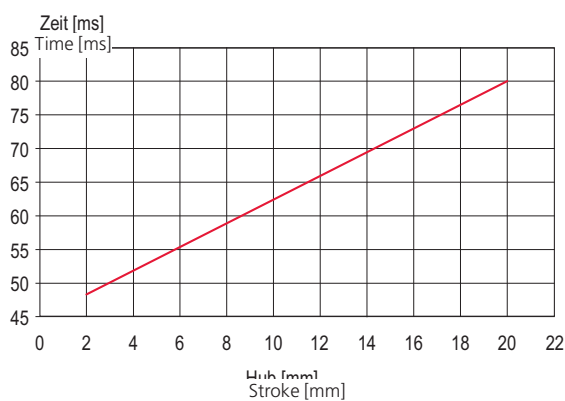

CS 6/40-ED

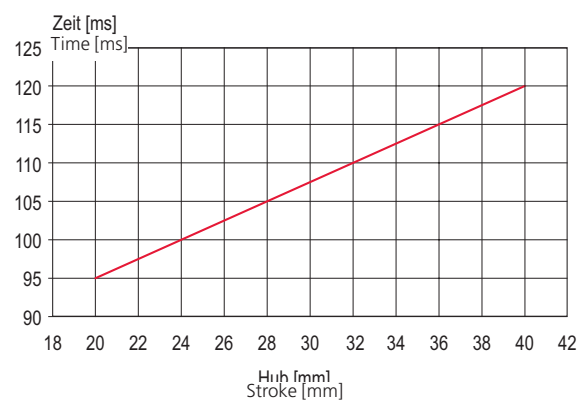



# Compact slides CS

## CS 8

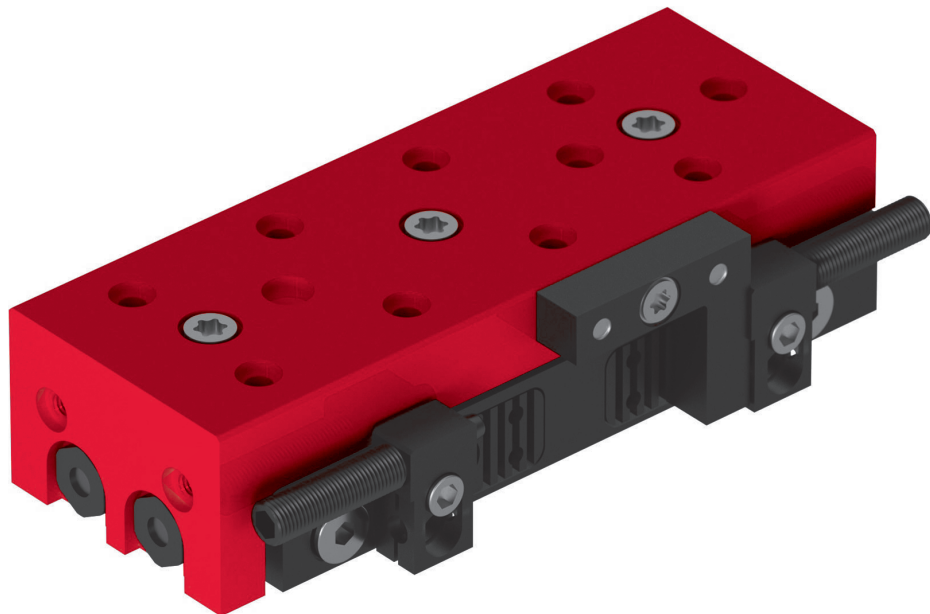

- Compact design
- Solid construction
- High rigidity

Type	CS 8/10	CS 8/30	CS 8/60
A	54 mm	90 mm	120 mm
B		66 mm	96 mm
C	7.5 mm	11 mm	8 mm
D	2 x 20 mm	3 x 20 mm	5 x 20 mm
E	20 mm	3 x 20 mm	4 x 20 mm
F		23.5 mm	23.5 mm
G	Screw-through (CS 8/30 and CS 8/60)		
P	M5	M5	M5

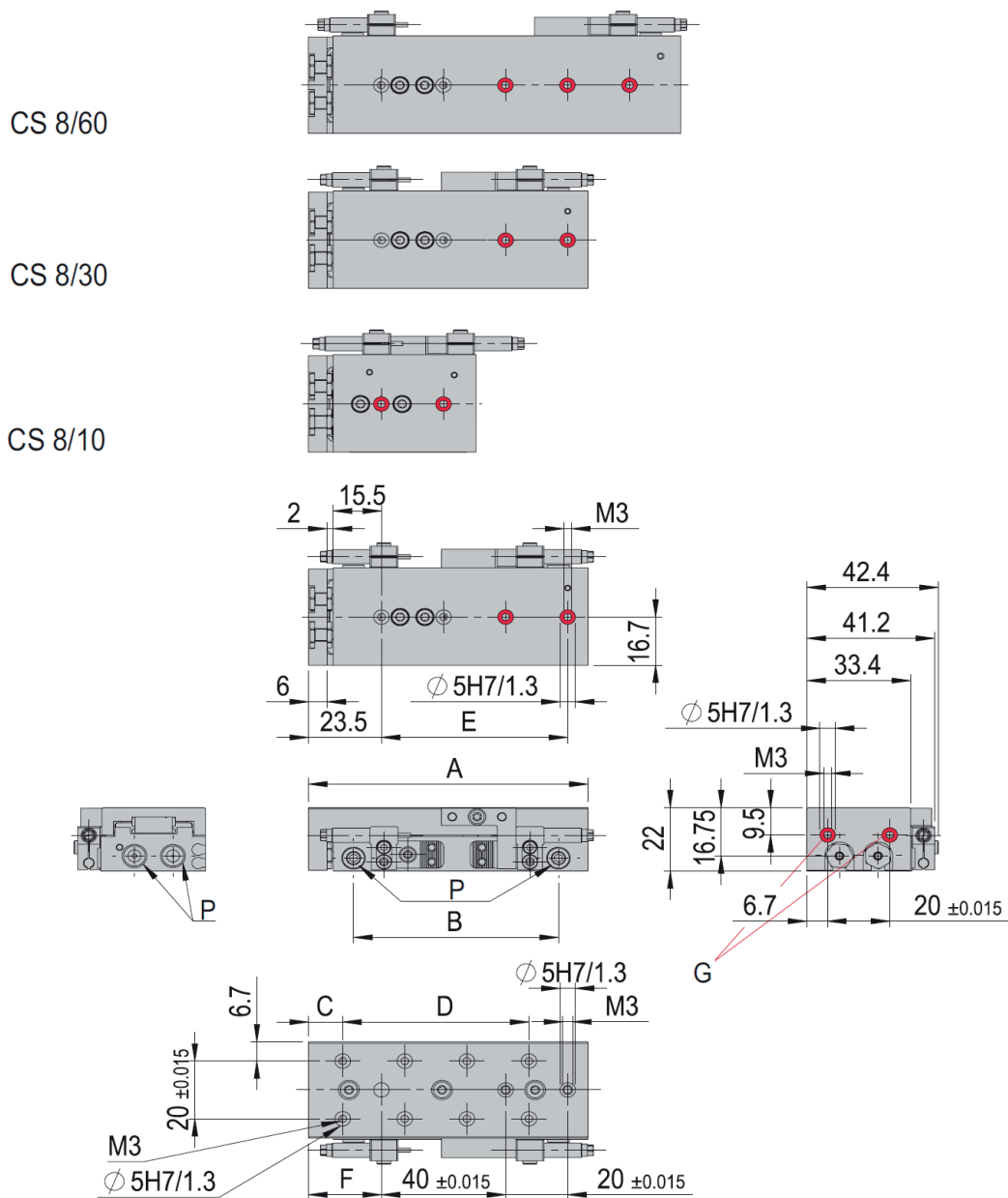

Bores can be screwed through

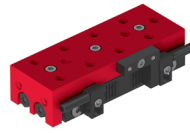

CS 8	
Attachment grid	20 x 20 mm
Attachment thread	M3
Operating pressure	6 +/- 2 bar
Air connection P	M5
Cylinder Ø	2 x 6 mm
Retract piston force	25 N
Extend piston force	34 N
Operating temperature	0 - 50 °C
Storage temperature	0 - 50 °C
Humidity	< 90 %
Medium filtered compressed air	10 - 40 µm

Type	CS 8/10-ED	CS 8/10-SD	CS 8/30-ED	CS 8/30-SD	CS 8/60-ED	CS 8/60-SD
<b>Order number</b>	<b>50300525</b>	<b>50036720</b>	<b>50300526</b>	<b>50035820</b>	<b>50300527</b>	<b>50035829</b>
Stroke H	10 mm	10 mm	30 mm	30 mm	60 mm	60 mm
Stroke limitation	2 x 10 mm	2 x 10 mm	2 x 25 mm	2 x 25 mm	2 x 25 mm	2 x 25 mm
Net weight	0.176 kg	0.175 kg	0.241 kg	0.24 kg	0.288 kg	0.287 kg
Moving weight	0.07 kg	0.07 kg	0.11 kg	0.11 kg	0.14 kg	0.14 kg
Air consumption/cycle	0.005 NL	0.005 NL	0.014 NL	0.014 NL	0.027 NL	0.027 NL
Noise level	60 dB (A)	60 dB (A)	60 dB (A)	60 dB (A)	60 dB (A)	60 dB (A)
Repeat accuracy	+/- 0.01 mm	+/- 0.01 mm	+/- 0.01 mm	+/- 0.01 mm	+/- 0.01 mm	+/- 0.01 mm
Maximum speed	1 m/s	1 m/s	1 m/s	1 m/s	1 m/s	1 m/s
Minimum speed	0.05 m/s	0.05 m/s	0.05 m/s	0.05 m/s	0.05 m/s	0.05 m/s
Mounting position	✦	✦	✦	✦	✦	✦

The technical data refers to a nominal pressure of 6 bar under Afag standard test conditions. The maximum payloads are listed in the payloads table in the slide loads section.  
 Note: the CS 8/...-ED are supplied with an elastomer damper ASED  
 The CS 8/...-SD are supplied with a hydraulic shock absorber ASSD  
 The CS 8/...-SDH are supplied with a hydraulic shock absorber and with a stop sleeve  
 The module can be operated with lubricated or dry air.  
 Cleanroom class ISO 14644-1, class ISO 7

### Included in the delivery (Catalogue HT accessories)

- 2x Centering bushing Ø5x2.5
- 2x Special screw M3x14.8/4
- 2x Special screw M3 x 16/6
- 2x Shock absorber ASSD M5x0.5 -2
- 2x Shock absorber ASED M5x05 -1

### Accessories (Catalogue HT accessories)

- INI c10x28.5-Em-PNP-NO-M8x1

### Alternative accessories (Catalogue HT accessories)

- Steel stop ASS 05/12
- Steel stop ASS 05/22
- Steel stop ASS 05/37
- Steel stop ASS 03/25
- INI d3x22-Sn0.8-PNP-NO-M8x1
- INI c10x19.5-Em-PNP-NO-M8x1



Type	CS 8/10-SDH	CS 8/30-SDH	CS 8/60-SDH
A	54 mm	90 mm	120 mm
B		66 mm	96 mm
C	7.5 mm	11 mm	8 mm
D	2 x 20 mm	3 x 20 mm	5 x 20 mm
E	20 mm	3 x 20 mm	4 x 20 mm
F		23.5 mm	23.5 mm
G	Screw-through (CS 8/30 and CS 8/60)		
P	M5	M5	M5

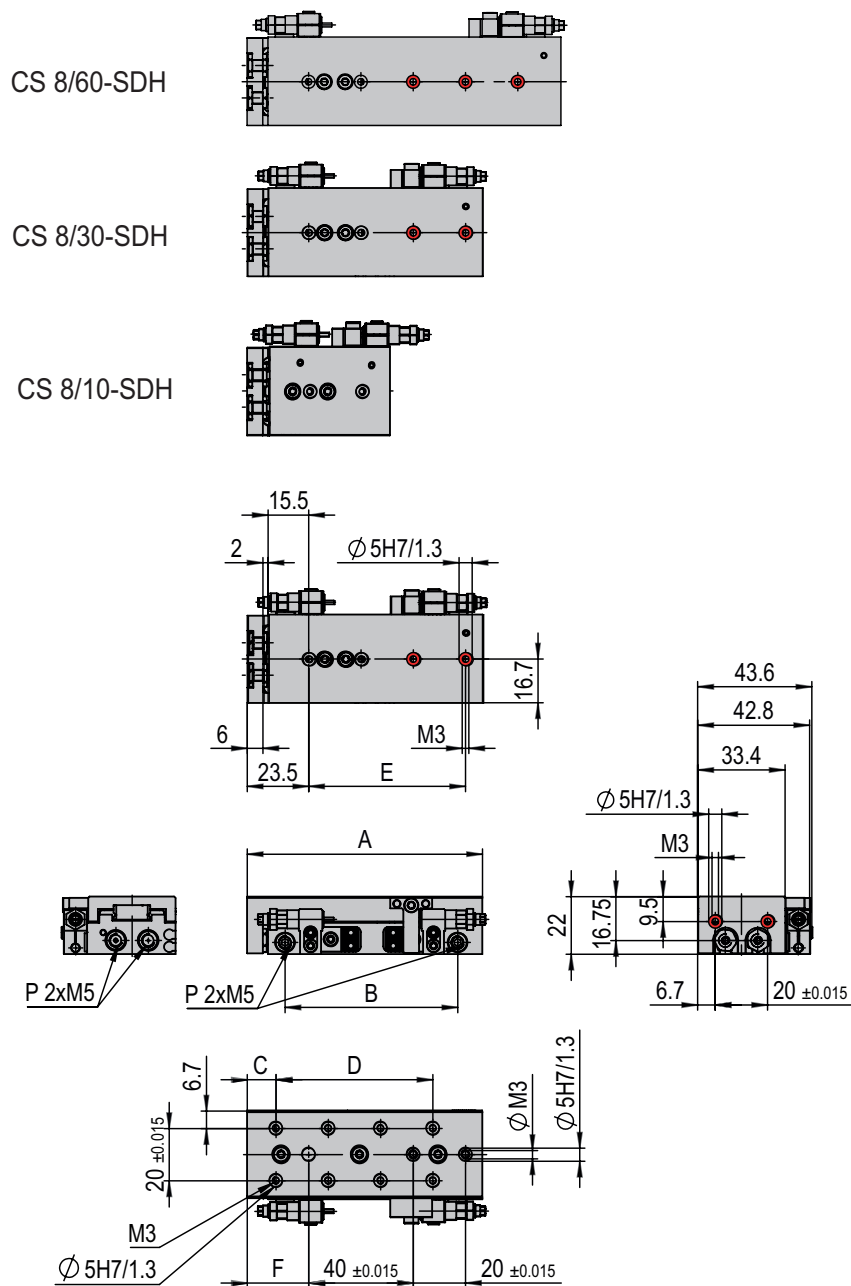

 Bores can be screwed through

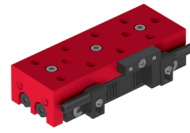

CS 8	
Attachment grid	20 x 20 mm
Attachment thread	M3
Operating pressure	6 +/- 2 bar
Air connection P	M5
Cylinder Ø	2 x 6 mm
Retract piston force	25 N
Extend piston force	34 N
Operating temperature	0 - 50 °C
Storage temperature	0 - 50 °C
Humidity	< 90 %
Medium filtered compressed air	10 - 40 µm

Type	CS 8/10-SDH	CS 8/30-SDH	CS 8/60-SDH
<b>Order number</b>	<b>50509361</b>	<b>50509609</b>	<b>50509576</b>
Stroke H	10 mm	30 mm	60 mm
Stroke limitation	2 x 10 mm	2 x 25 mm	2 x 25 mm
Net weight	0.181 kg	0.246 kg	0.293 kg
Moving weight	0.07 kg	0.11 kg	0.14 kg
Air consumption/cycle	0.005 NL	0.014 NL	0.027 NL
Noise level	60 dB (A)	60 dB (A)	60 dB (A)
Repeat accuracy	+/- 0.01 mm	+/- 0.01 mm	+/- 0.01 mm
Maximum speed	1 m/s	1 m/s	1 m/s
Minimum speed	0.05 m/s	0.05 m/s	0.05 m/s
Mounting position	✦	✦	✦

The technical data refers to a nominal pressure of 6 bar under Afag standard test conditions. The maximum payloads are listed in the payloads table in the slide loads section.

Note: the CS 8/...-ED are supplied with an elastomer damper ASED

The CS 8/...-SD are supplied with a hydraulic shock absorber ASSD

The CS 8/...-SDH are supplied with a hydraulic shock absorber and with a stop sleeve

The module can be operated with lubricated or dry air.

Cleanroom class ISO 14644-1, class ISO 7

### Included in the delivery (Catalogue HT accessories)

- 2x Centering bushing Ø5x2.5
- 2x Special screw M3x14.8/4
- 2x Special screw M3 x 16/6
- 2x Shock absorber ASSD M5x0.5 -2
- 2x Shock absorber ASED M5x05 -1

### Accessories (Catalogue HT accessories)

- INI c10x28.5-Em-PNP-NO-M8x1

### Alternative accessories (Catalogue HT accessories)

- Steel stop ASS 05/12
- Steel stop ASS 05/22
- Steel stop ASS 05/37
- Steel stop ASS 03/25
- INI d3x22-Sn0.8-PNP-NO-M8x1
- INI c10x19.5-Em-PNP-NO-M8x1

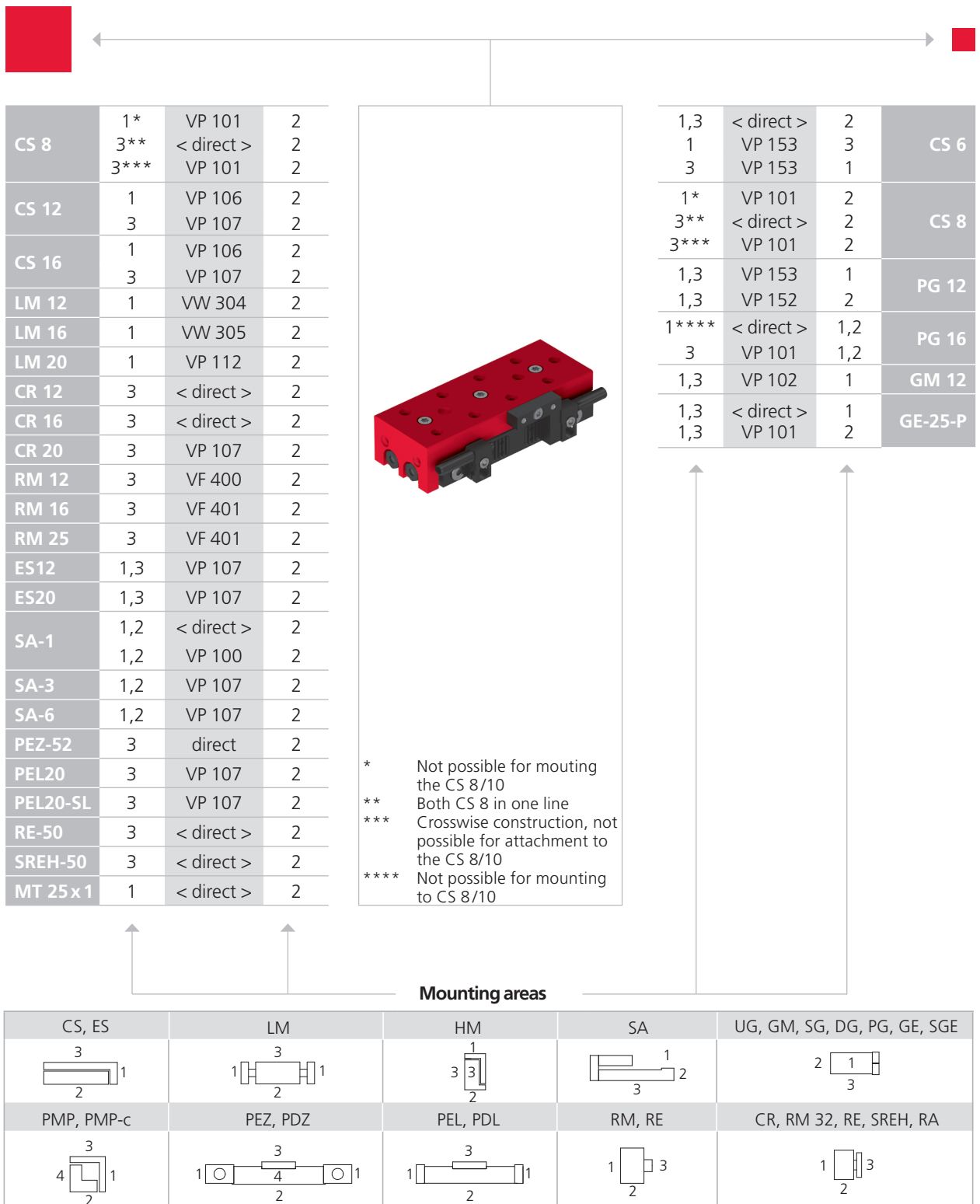

Note that there might be different mounting positions from one module to another one.

The required connection elements and the range of support columns are depicted in the catalogue HT accessories.

Type	CS 8/10-ED	CS 8/10-SD	CS 8/10-SDH	CS 8/30-ED	CS 8/30-SD	CS 8/30-SDH	CS 8/60-ED	CS 8/60-SD	CS 8/60-SDH
Max. torque $M_x$	3.6 Nm	3.6 Nm	3.6 Nm	5.4 Nm	5.4 Nm	5.4 Nm	5.4 Nm	5.4 Nm	5.4 Nm
Max. torque $M_y$	1.7 Nm	1.7 Nm	1.7 Nm	3.6 Nm	3.6 Nm	3.6 Nm	3.6 Nm	3.6 Nm	3.6 Nm
Max. torque $M_z$	1.7 Nm	1.7 Nm	1.7 Nm	3.6 Nm	3.6 Nm	3.6 Nm	3.6 Nm	3.6 Nm	3.6 Nm
Effective distance $W_x$	24 mm	24 mm	24 mm	28 mm	28 mm	28 mm	28 mm	28 mm	28 mm
Effective distance $W_y$	20 mm	20 mm	20 mm	20 mm	20 mm	20 mm	20 mm	20 mm	20 mm
Effective distance $W_z$	6.5 mm	6.5 mm	6.5 mm	6.5 mm	6.5 mm	6.5 mm	6.5 mm	6.5 mm	6.5 mm

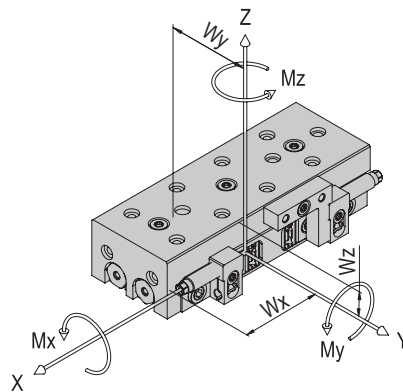

Maximum payload/type	CS 8/10-ED	CS 8/10-SD	CS 8/10-SDH	CS 8/30-ED	CS 8/30-SD	CS 8/30-SDH	CS 8/60-ED	CS 8/60-SD	CS 8/60-SDH
Installation position (horizontal) for mounting side 1	0.2 kg	0.3 kg	0.3 kg	0.2 kg	0.4 kg	0.4 kg	0.2 kg	0.4 kg	0.4 kg
Installation position (horizontal) for mounting side 3	0.2 kg	0.3 kg	0.3 kg	0.2 kg	0.7 kg	0.7 kg	0.2 kg	0.7 kg	0.7 kg
Installation position (vertical) for mounting side 1	0.2 kg	0.3 kg	0.3 kg	0.2 kg	0.4 kg	0.4 kg	0.2 kg	0.4 kg	0.4 kg
Installation position (vertical) for mounting side 3	0.2 kg	0.3 kg	0.3 kg	0.2 kg	0.7 kg	0.7 kg	0.2 kg	0.7 kg	0.7 kg

Assembly sides module mounting

horizontal:

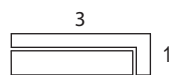

vertical:

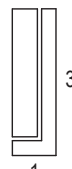

If the specified maximum payloads are exceeded, it must be ensured that the corresponding moments do not affect the service life of the module. All torques are static. In the event of critical applications, please contact Afag.

## Operation time diagrams

CS 8/10-ED elastomer

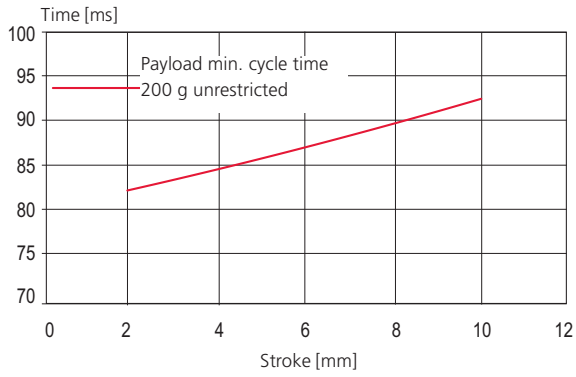

CS 8/10-SD hydraulic

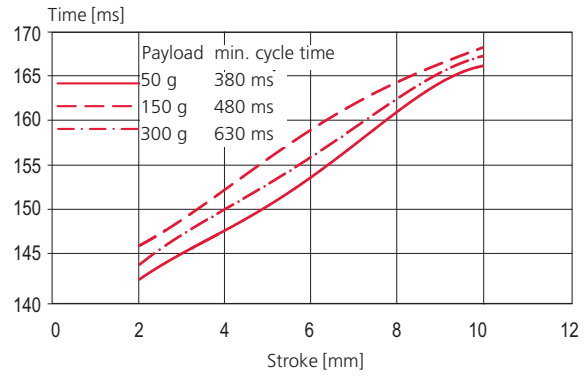

CS 8/30-ED elastomer

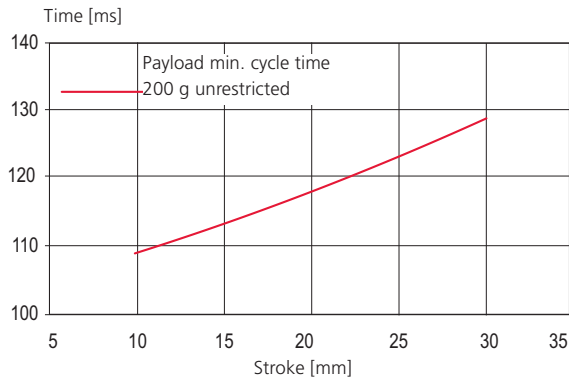

CS 8/30-SD hydraulic

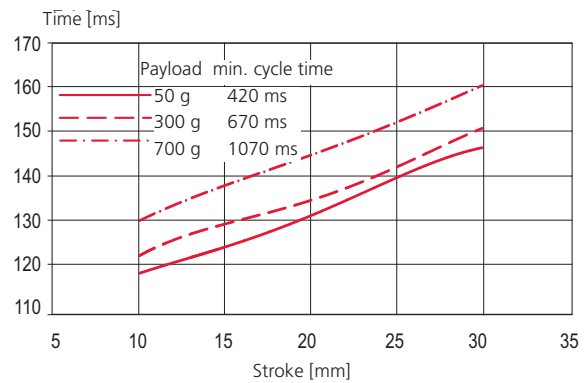

CS 8/60-ED elastomer

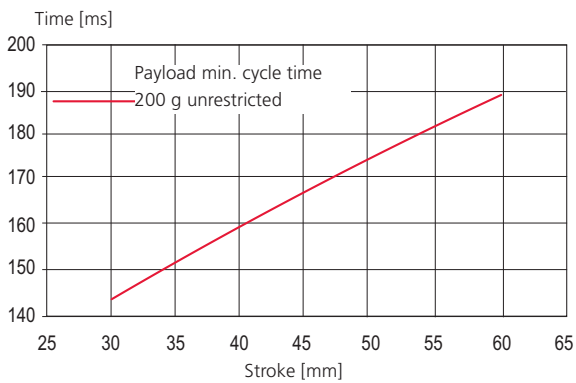

CS 8/60-SD hydraulic

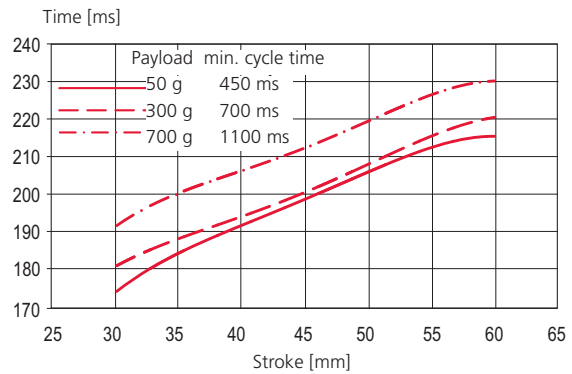

# Compact slides CS

## CS 12

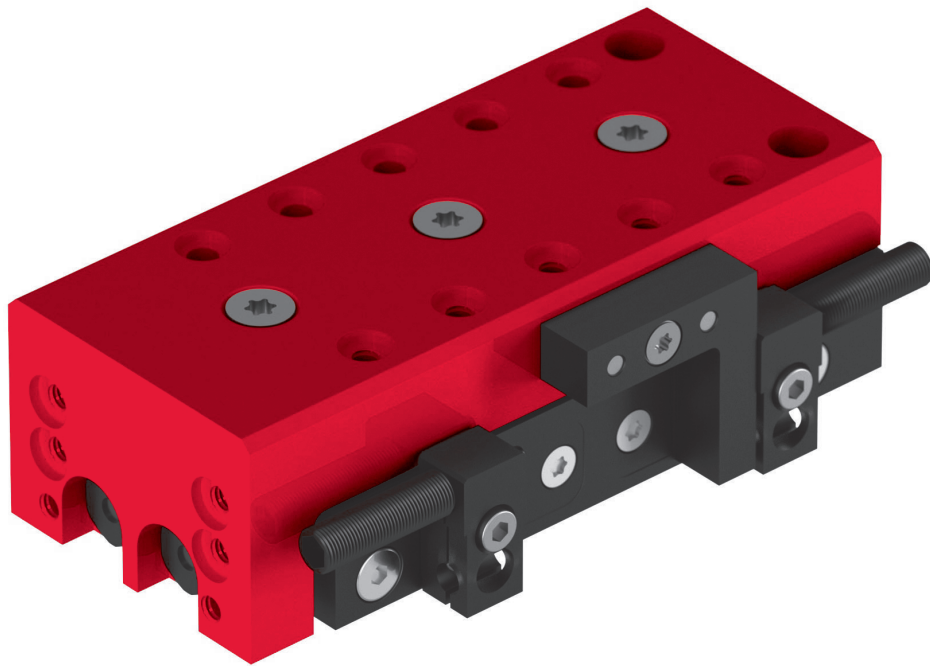

- Compact design
- Solid construction
- High rigidity

Type	CS 12/30	CS 12/60	CS 12/90
A	102 mm	132 mm	162 mm
B	70 mm	100 mm	130 mm
C	4 x 15 mm	6 x 15 mm	8 x 15 mm
D	4 x 15 mm	6 x 15 mm	8 x 15 mm

CS 12/90

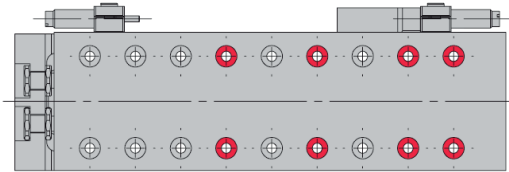

CS 12/60

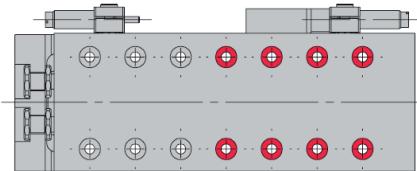

CS 12/30

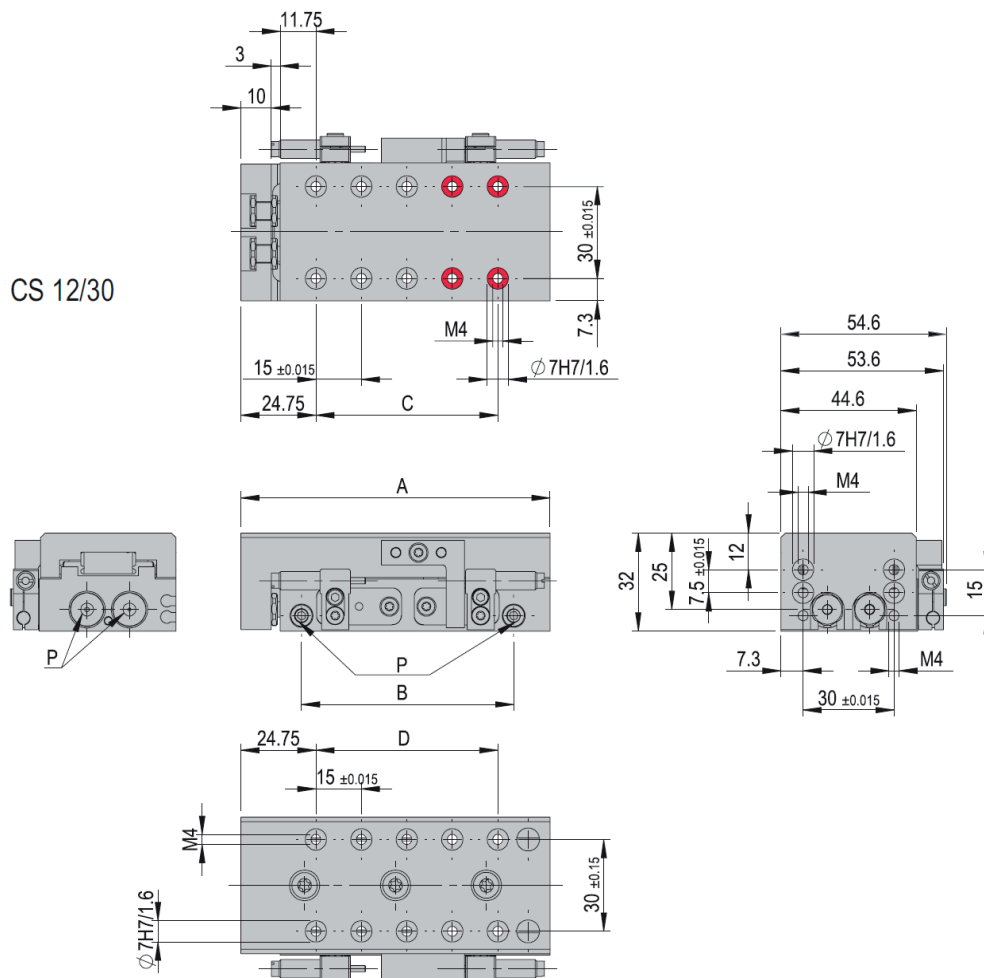

Bores can be screwed through

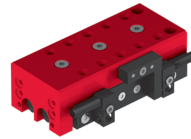

CS 12	
Attachment grid	30 x 30 mm
Attachment thread	M4
Operating pressure	6 +/- 2 bar
Air connection P	M5
Cylinder Ø	2 x 10 mm
Retract piston force	71 N
Extend piston force	94 N
Operating temperature	0 - 50 °C
Storage temperature	0 - 50 °C
Humidity	< 90 %
Medium filtered compressed air	10 - 40 µm

Type	CS 12/30-ED	CS 12/30-SD	CS 12/60-ED	CS 12/60-SD	CS 12/90-ED	CS 12/90-SD
<b>Order number</b>	<b>50300528</b>	<b>50048476</b>	<b>50300529</b>	<b>50050602</b>	<b>50300530</b>	<b>50050825</b>
Stroke H	30 mm	30 mm	60 mm	60 mm	90 mm	90 mm
Stroke limitation	2 x 25 mm	2 x 25 mm	2 x 25 mm	2 x 25 mm	2 x 25 mm	2 x 25 mm
Net weight	0.5 kg	0.5 kg	0.864 kg	0.61 kg	0.73 kg	0.73 kg
Moving weight	0.24 kg	0.24 kg	0.3 kg	0.3 kg	0.36 kg	0.36 kg
Air consumption/cycle	0.038 NL	0.038 NL	0.076 NL	0.076 NL	0.114 NL	0.114 NL
Noise level	64 dB (A)	64 dB (A)	64 dB (A)	64 dB (A)	64 dB (A)	64 dB (A)
Repeat accuracy	+/- 0.01 mm	+/- 0.01 mm	+/- 0.01 mm	+/- 0.01 mm	+/- 0.01 mm	+/- 0.01 mm
Maximum speed	1 m/s	1 m/s	1 m/s	1 m/s	1 m/s	1 m/s
Minimum speed	0.02 m/s	0.02 m/s	0.02 m/s	0.02 m/s	0.02 m/s	0.02 m/s
Mounting position	↕	↕	↕	↕	↕	↕

The technical data refers to a nominal pressure of 6 bar under Afag standard test conditions. The maximum payloads are listed in the payloads table in the slide loads section.

Note: the CS 12/...-ED are supplied with an elastomer damper ASED

The CS 12/...-SD are supplied with a hydraulic shock absorber ASSD

The CS 12/...-SDH are supplied with a hydraulic shock absorber and with a stop sleeve

The module can be operated with lubricated or dry air.

Cleanroom class ISO 14644-1, class ISO 7

### Included in the delivery

(Catalogue HT accessories)

- 2x Centering bushing Ø7x3
- 4x Special screw M4 x 20/8
- 2x Shock absorber ASSD M6x0.5 - 4
- 2x Shock absorber ASED M6x0.5 - 1

### Accessories

(Catalogue HT accessories)

- INI c10x28.5-Em-PNP-NO-M8x1

### Alternative accessories

(Catalogue HT accessories)

- Steel stop ASS 04/25
- INI d4x25-Sn1.0-PNP-NO-M8x1
- INI c10x19.5-Em-PNP-NO-M8x1



Type	CS 12/30-SDH	CS 12/60-SDH	CS 12/90-SDH
A	102 mm	132 mm	162 mm
B	70 mm	100 mm	130 mm
C	4 x 15 mm	6 x 15 mm	8 x 15 mm
D	4 x 15 mm	6 x 15 mm	8 x 15 mm

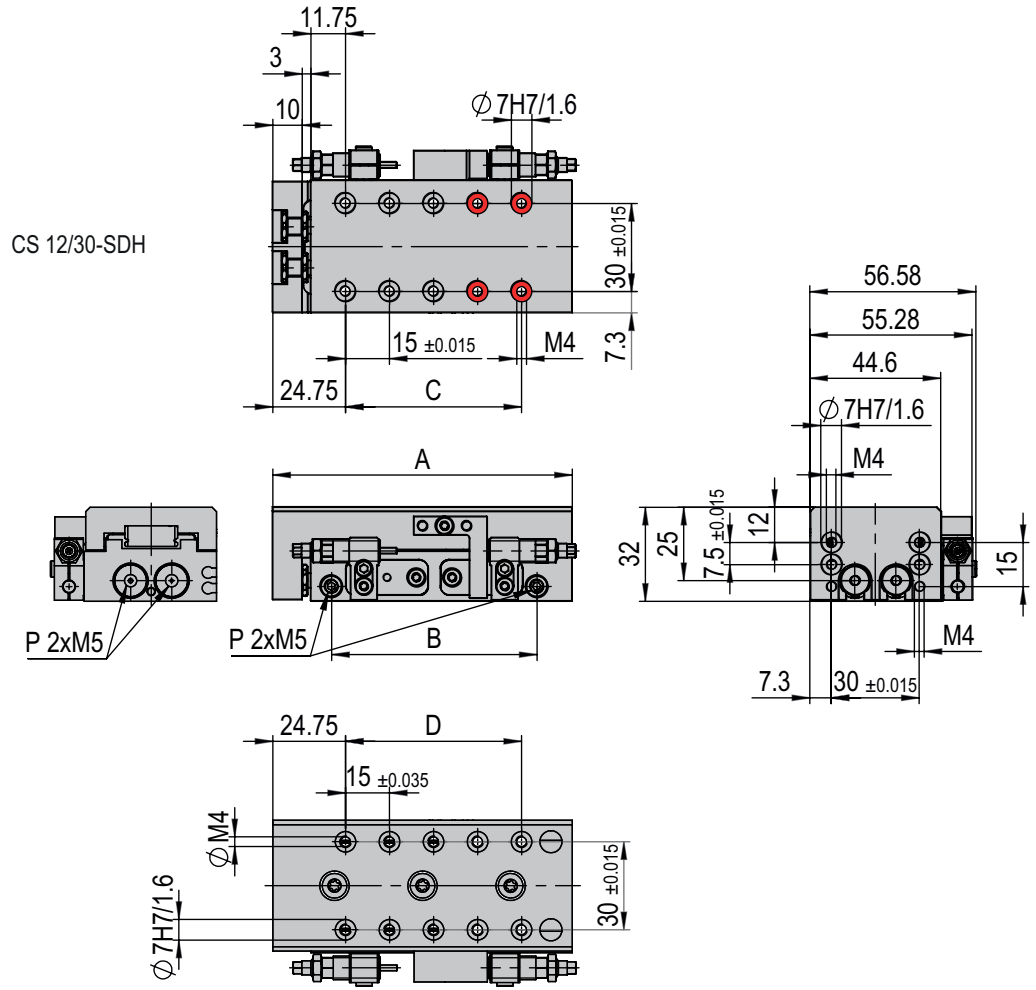
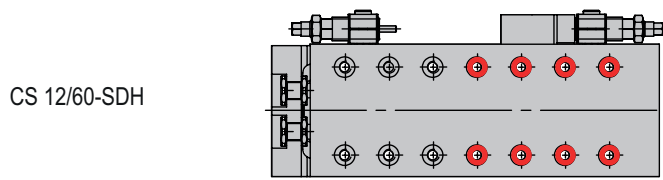
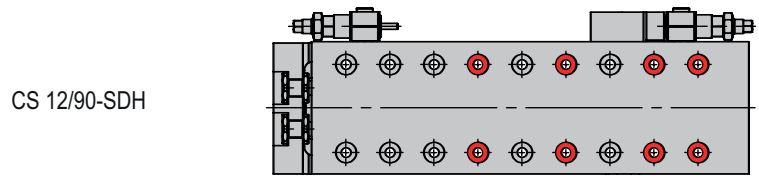

Bores can be screwed through

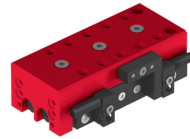

CS 12 -SDH	
Attachment grid	30 x 30 mm
Attachment thread	M4
Operating pressure	6 +/- 2 bar
Air connection P	M5
Cylinder Ø	2 x 10 mm
Retract piston force	71 N
Extend piston force	94 N
Operating temperature	0 - 50 °C
Storage temperature	0 - 50 °C
Humidity	< 90 %
Medium filtered compressed air	10 - 40 µm

Type	CS 12/30-SDH	CS 12/60-SDH	CS 12/90-SDH
<b>Order number</b>	<b>50509653</b>	<b>50509713</b>	<b>50509725</b>
Stroke H	30 mm	60 mm	90 mm
Stroke limitation	2 x 25 mm	2 x 25 mm	2 x 25 mm
Net weight	0.5 kg	0.61 kg	0.73 kg
Moving weight	0.24 kg	0.3 kg	0.36 kg
Air consumption/cycle	0.038 NL	0.076 NL	0.114 NL
Noise level	64 dB (A)	64 dB (A)	64 dB (A)
Repeat accuracy	+/- 0.01 mm	+/- 0.01 mm	+/- 0.01 mm
Maximum speed	1 m/s	1 m/s	1 m/s
Minimum speed	0.02 m/s	0.02 m/s	0.02 m/s
Mounting position	✦	✦	✦

The technical data refers to a nominal pressure of 6 bar under Afag standard test conditions. The maximum payloads are listed in the payloads table in the slide loads section.  
 Note: the CS 12/...-ED are supplied with an elastomer damper ASED  
 The CS 12/...-SD are supplied with a hydraulic shock absorber ASSD  
 The CS 12/...-SDH are supplied with a hydraulic shock absorber and with a stop sleeve  
 The module can be operated with lubricated or dry air.  
 Cleanroom class ISO 14644-1, class ISO 7

### Included in the delivery

(Catalogue HT accessories)

- 2x Centering bushing Ø7x3
- 4x Special screw M4 x 20/8
- 2x Shock absorber ASSD M6x0.5 - 4
- 2x Shock absorber ASED M6x0.5 - 1

### Accessories

(Catalogue HT accessories)

- INI c10x28.5-Em-PNP-NO-M8x1

### Alternative accessories

(Catalogue HT accessories)

- Steel stop ASS 04/25
- INI d4x25-Sn1.0-PNP-NO-M8x1
- INI c10x19.5-Em-PNP-NO-M8x1

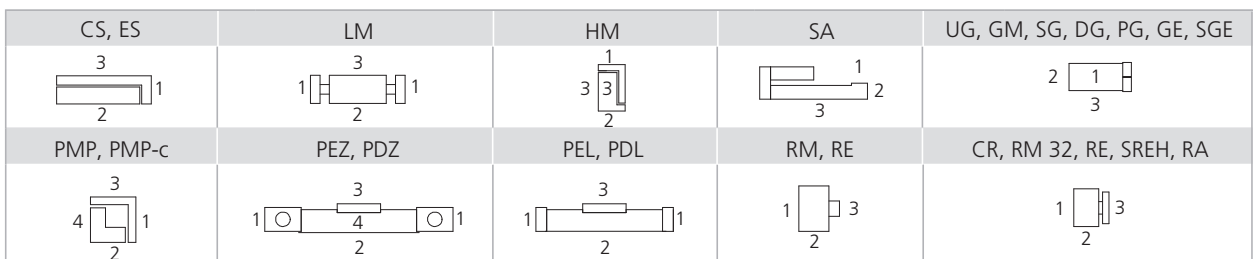
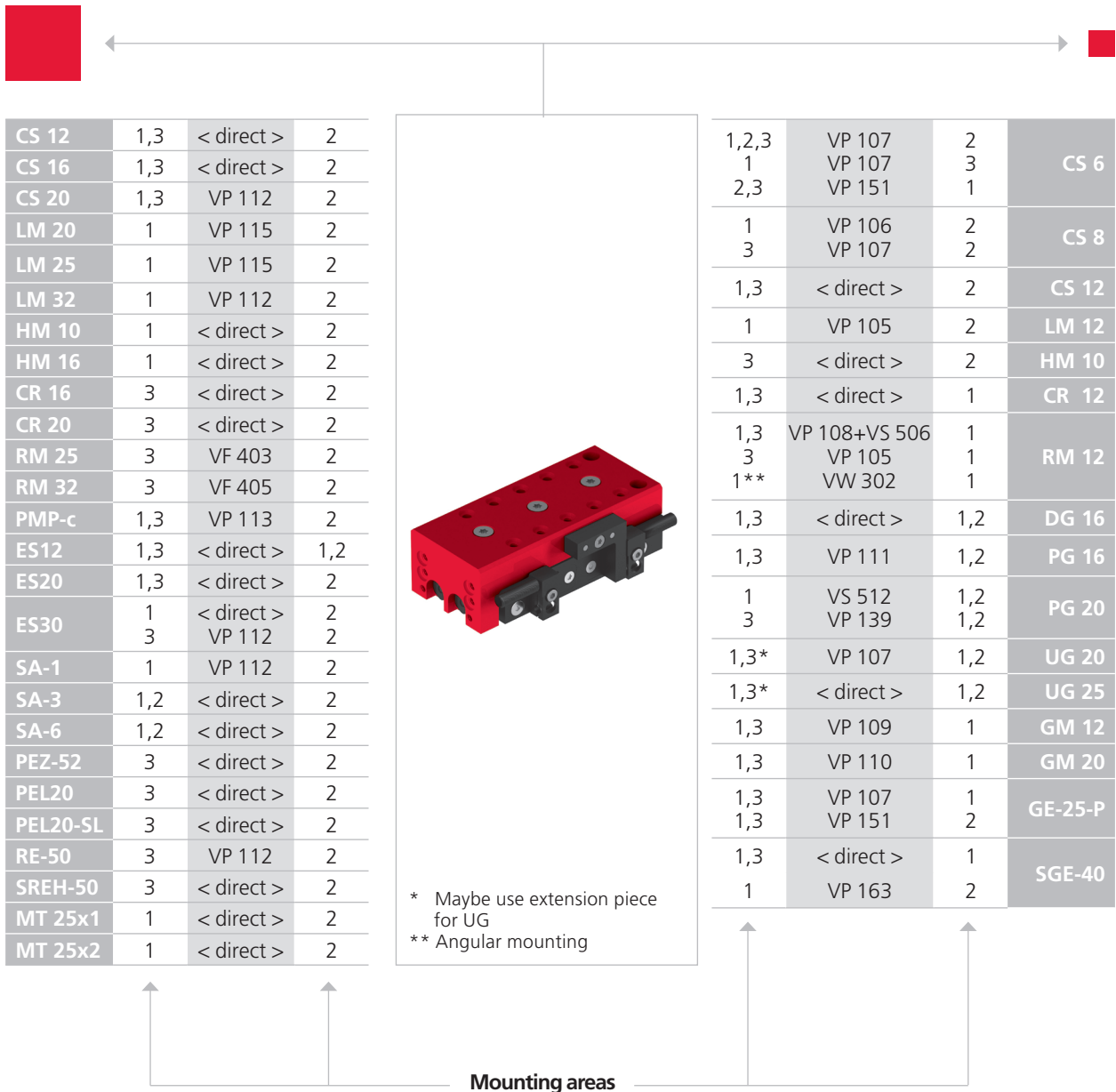

Note that there might be different mounting positions from one module to another one.  
The required connection elements and the range of support columns are depicted in the catalogue HT accessories.

Type	CS 12/30-	CS 12/30-	CS 12/30-	CS 12/60-	CS 12/60-	CS 12/60-	CS 12/90-	CS 12/90-	CS 12/90-
	ED	SD	SDH	ED	SD	SDH	ED	SD	SDH
Max. torque $M_x$	13 Nm	13 Nm	13 Nm	13 Nm	13 Nm	13 Nm	13 Nm	13 Nm	13 Nm
Max. torque $M_y$	8 Nm	8 Nm	8 Nm	8 Nm	8 Nm	8 Nm	8 Nm	8 Nm	8 Nm
Max. torque $M_z$	8 Nm	8 Nm	8 Nm	8 Nm	8 Nm	8 Nm	8 Nm	8 Nm	8 Nm
Effective distance $W_x$	36.5 mm	36.5 mm	36.5 mm	36.5 mm	36.5 mm	36.5 mm	36.5 mm	36.5 mm	36.5 mm
Effective distance $W_y$	26 mm	26 mm	26 mm	26 mm	26 mm	26 mm	26 mm	26 mm	26 mm
Effective distance $W_z$	22 mm	22 mm	22 mm	22 mm	22 mm	22 mm	22 mm	22 mm	22 mm

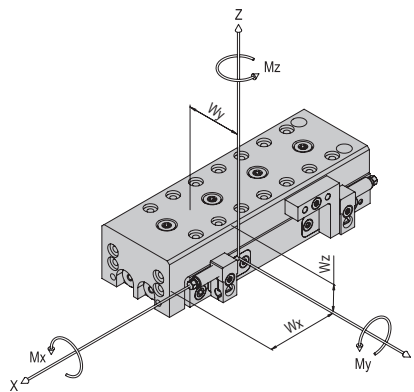

Maximum payload/type	CS 12/30-	CS 12/30-	CS 12/30-	CS 12/60-	CS 12/60-	CS 12/60-	CS 12/90-	CS 12/90-	CS 12/90-
	ED	SD	SDH	ED	SD	SDH	ED	SD	SDH
Installation position (horizontal) for mounting side 1	0.3 kg	0.7 kg	0.7 kg	0.3 kg	0.7 kg	0.7 kg	0.3 kg	0.7 kg	0.7 kg
Installation position (horizontal) for mounting side 3	0.3 kg	1.2 kg	1.2 kg	0.3 kg	1.2 kg	1.2 kg	0.3 kg	1.2 kg	1.2 kg
Installation position (vertical) for mounting side 1	0.3 kg	0.7 kg	0.7 kg	0.3 kg	0.7 kg	0.7 kg	0.3 kg	0.7 kg	0.7 kg
Installation position (vertical) for mounting side 3	0.3 kg	1.2 kg	1.2 kg	0.3 kg	1.2 kg	1.2 kg	0.3 kg	1.2 kg	1.2 kg

Assembly sides module mounting

horizontal:

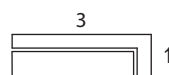

vertical:

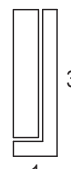

If the specified maximum payloads are exceeded, it must be ensured that the corresponding moments do not affect the service life of the module. All torques are static. In the event of critical applications, please contact Afag.

## Operation time diagrams

CS 12/30-ED elastomer

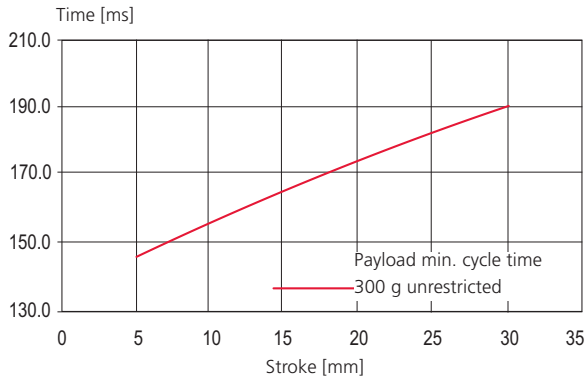

CS 12/30-SD hydraulic

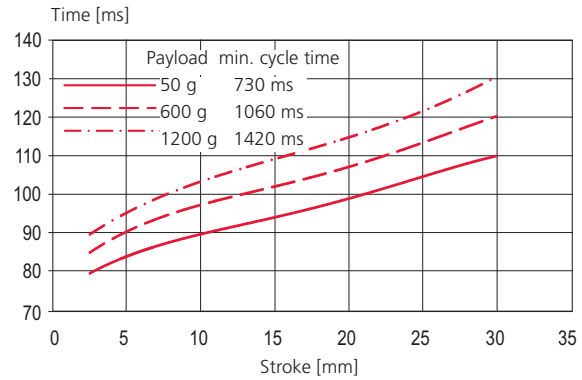

CS 12/60-ED elastomer

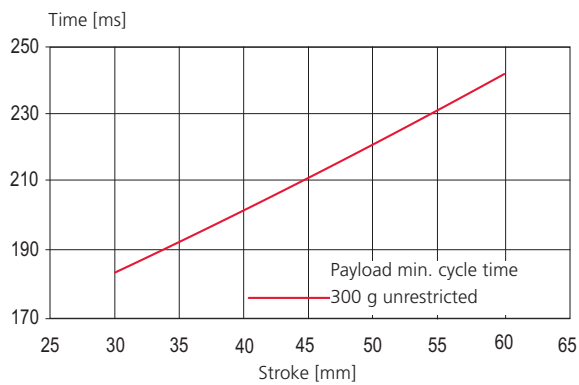

CS 12/60-SD hydraulic

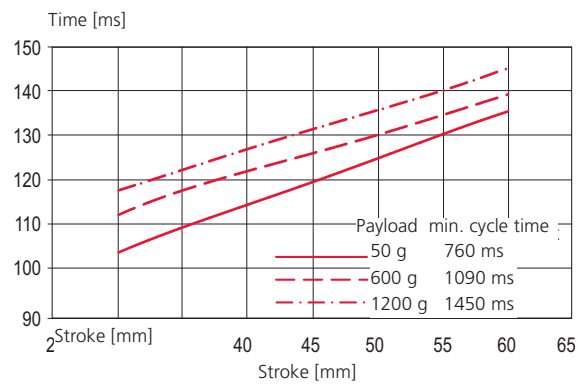

CS 12/90-ED elastomer

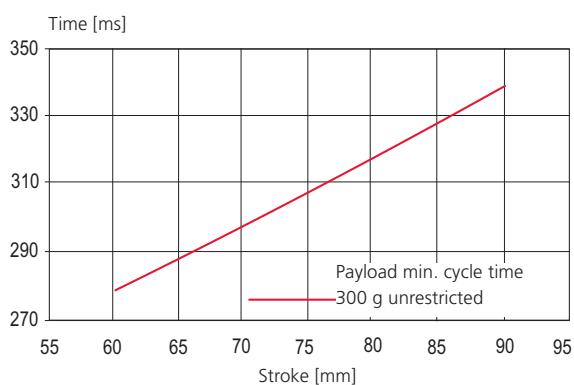

CS 12/90-SD hydraulic

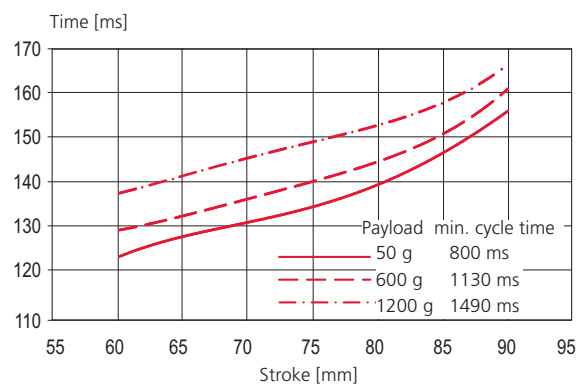

# Compact slides CS

## CS 16

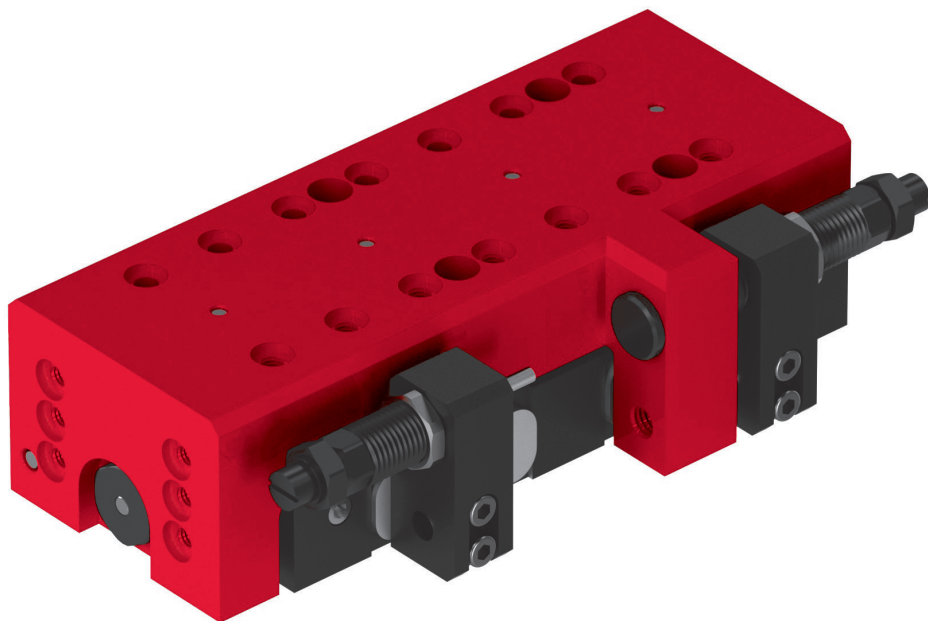

- Compact design
- Solid construction
- High rigidity
- Intermediate stop for 3rd Position

Type	CS 16/30	CS 16/60	CS 16/90	CS 16/120
A	6 x 15 mm	9 x 15 mm	11 x 15 mm	14 x 15 mm
B	93 mm	135.5 mm	167.5 mm	210 mm
C	130 mm	177 mm	209 mm	252 mm
D	6 x 15 mm	9 x 15 mm	11 x 15 mm	14 x 15 mm

CS 16/120

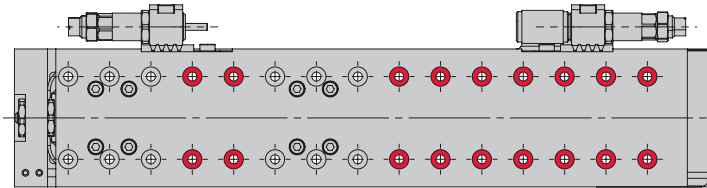

CS 16/90

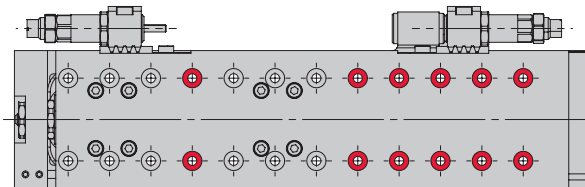

CS 16/60

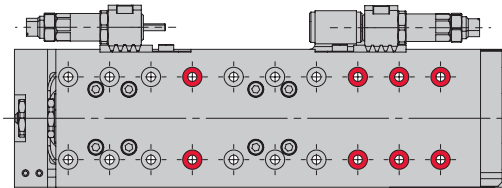

CS 16/30

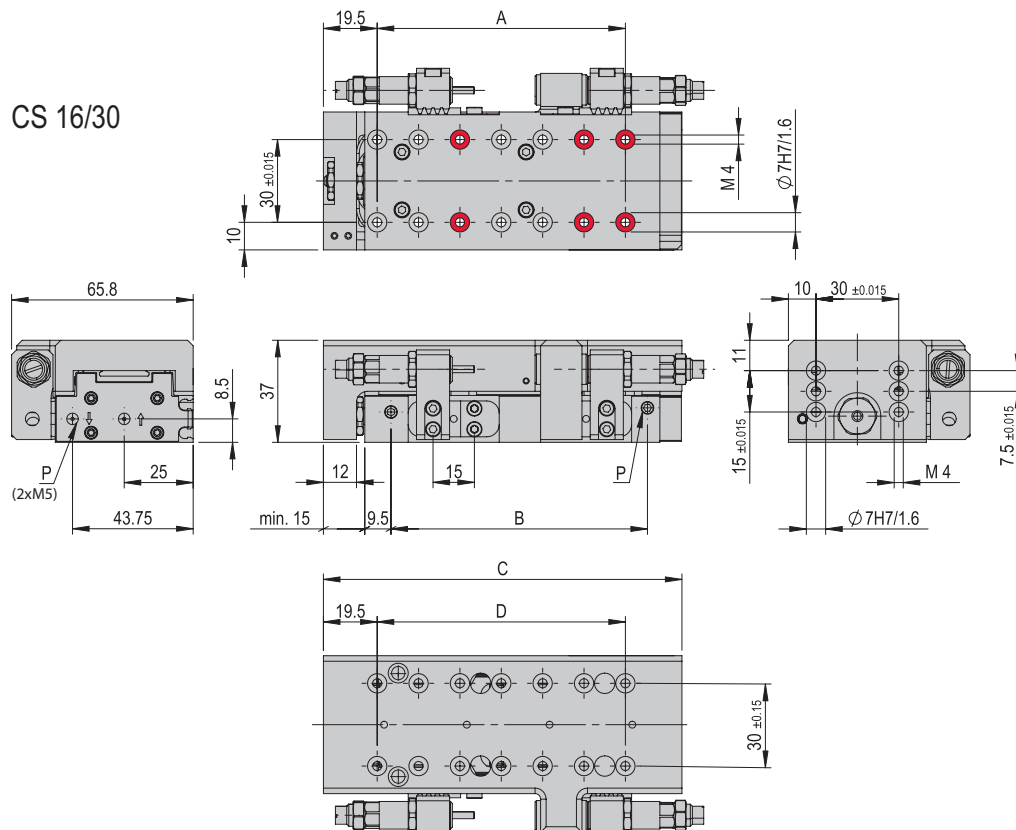

 Bores can be screwed through

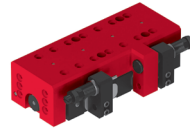

CS 16	
Attachment grid	30 x 30 mm
Attachment thread	M4
Operating pressure	6 +/- 2 bar
Air connection P	M5
Cylinder Ø	16 mm
Retract piston force	103 N
Extend piston force	120 N
Operating temperature	0 - 50 °C
Storage temperature	0 - 50 °C
Humidity	< 90 %
Medium filtered compressed air	10 - 40 µm

Type	CS 16/30	CS 16/60	CS 16/90	CS 16/120
<b>Order number</b>	<b>50167742</b>	<b>50154069</b>	<b>50154070</b>	<b>50154071</b>
Stroke H	30 mm	60 mm	90 mm	120 mm
Stroke limitation	2 x 30 mm	2 x 30 mm	2 x 30 mm	2 x 30 mm
Net weight	0.74 kg	0.98 kg	1.2 kg	1.27 kg
Moving weight	0.34 kg	0.48 kg	0.564 kg	0.671 kg
Air consumption/cycle	0.0554 NL	0.1109 NL	0.1664 NL	0.2218 NL
Noise level	64 dB (A)	64 dB (A)	64 dB (A)	64 dB (A)
Repeat accuracy	+/- 0.01 mm	+/- 0.01 mm	+/- 0.01 mm	+/- 0.01 mm
Maximum speed	1 m/s	1 m/s	1 m/s	1 m/s
Minimum speed	0.1 m/s	0.1 m/s	0.1 m/s	0.1 m/s
Mounting position	✦	✦	✦	✦

The technical data refers to a nominal pressure of 6 bar under Afag standard test conditions. The maximum payloads are listed in the payloads table in the slide loads section. The module can be operated with lubricated or dry air. Cleanroom class ISO 14644-1, class ISO 7

- Included in the delivery**  
(Catalogue HT accessories)
- 2x Centering bushing Ø7x3
  - 4x Special screw M4 x 20/8
  - 2x Stop sleeve ASH M10x1 -1
  - 2x Shock absorber SD M8x1 -4

- Accessories**
- Installation set proximity switch CS 16/CS 20 [p. 48]
  - Intermediate stop ZA-CS 16 [p. 46]
- (Catalogue HT accessories)
- INI c10x28.5-Em-PNP-NO-M8x1

- Alternative accessories**  
(Catalogue HT accessories)
- INI c10x19.5-Em-PNP-NO-M8x1
  - INI d4x25-Sn1.0-PNP-NO-M8x1



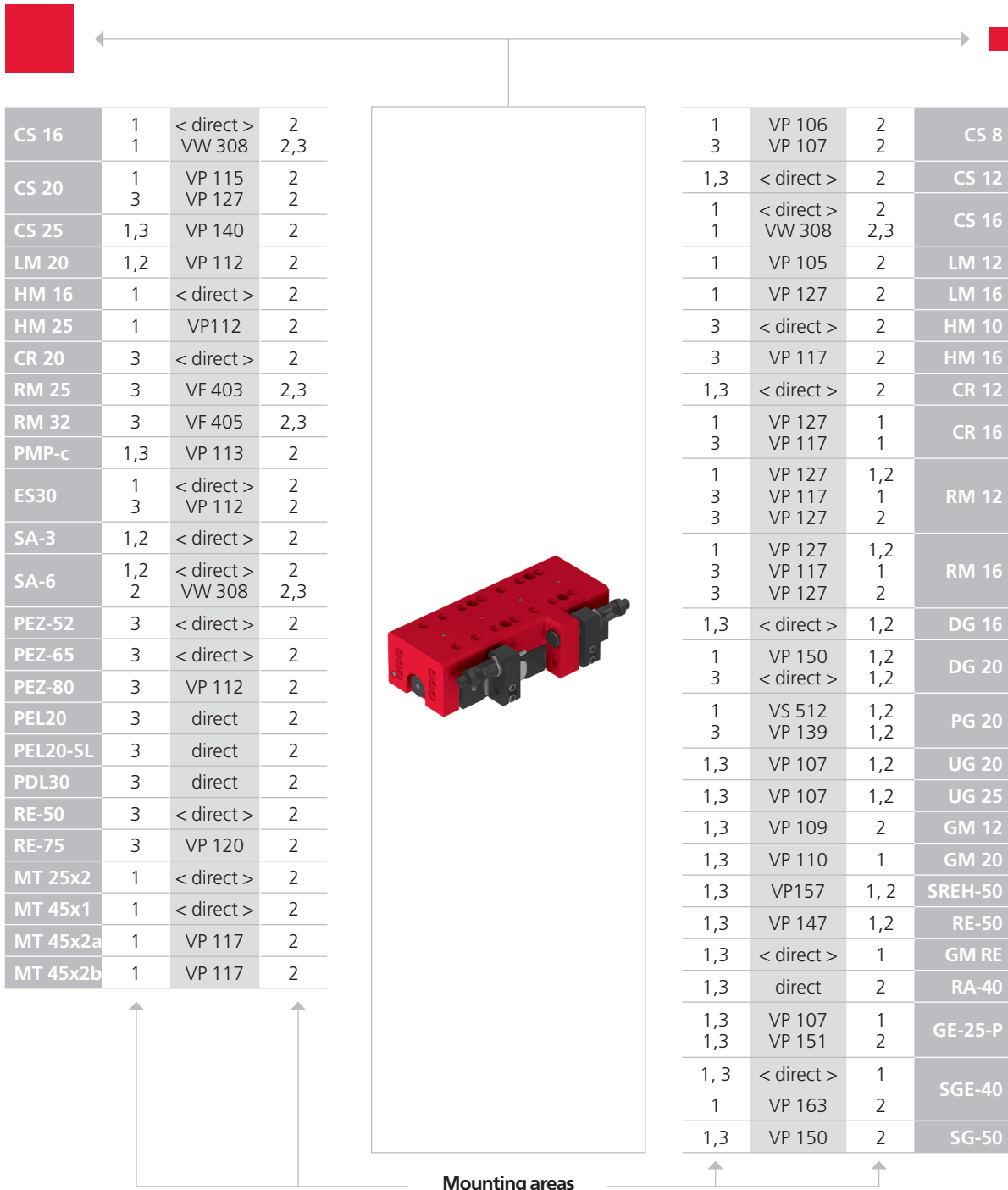

CS 16	1 1	< direct > VW 308	2 2,3
CS 20	1 3	VP 115 VP 127	2 2
CS 25	1,3	VP 140	2
LM 20	1,2	VP 112	2
HM 16	1	< direct >	2
HM 25	1	VP112	2
CR 20	3	< direct >	2
RM 25	3	VF 403	2,3
RM 32	3	VF 405	2,3
PMP-c	1,3	VP 113	2
ES30	1 3	< direct > VP 112	2 2
SA-3	1,2	< direct >	2
SA-6	1,2 2	< direct > VW 308	2 2,3
PEZ-52	3	< direct >	2
PEZ-65	3	< direct >	2
PEZ-80	3	VP 112	2
PEL20	3	direct	2
PEL20-SL	3	direct	2
PDL30	3	direct	2
RE-50	3	< direct >	2
RE-75	3	VP 120	2
MT 25x2	1	< direct >	2
MT 45x1	1	< direct >	2
MT 45x2a	1	VP 117	2
MT 45x2b	1	VP 117	2

1 3	VP 106 VP 107	2 2	CS 8
1,3	< direct >	2	CS 12
1 1	< direct > VW 308	2 2,3	CS 16
1	VP 105	2	LM 12
1	VP 127	2	LM 16
3	< direct >	2	HM 10
3	VP 117	2	HM 16
1,3	< direct >	2	CR 12
1 3	VP 127 VP 117	1 1	CR 16
1 3 3	VP 127 VP 117 VP 127	1,2 1 2	RM 12
1 3 3	VP 127 VP 117 VP 127	1,2 1 2	RM 16
1,3	< direct >	1,2	DG 16
1 3	VP 150 < direct >	1,2 1,2	DG 20
1 3	VS 512 VP 139	1,2 1,2	PG 20
1,3	VP 107	1,2	UG 20
1,3	VP 107	1,2	UG 25
1,3	VP 109	2	GM 12
1,3	VP 110	1	GM 20
1,3	VP157	1, 2	SREH-50
1,3	VP 147	1,2	RE-50
1,3	< direct >	1	GM RE
1,3	direct	2	RA-40
1,3 1,3	VP 107 VP 151	1 2	GE-25-P
1, 3	< direct >	1	SGE-40
1	VP 163	2	
1,3	VP 150	2	SG-50

Mounting areas

CS, ES 	LM 	HM 	SA 	UG, GM, SG, DG, PG, GE, SGE 
PMP, PMP-c 	PEZ, PDZ 	PEL, PDL 	RM, RE 	CR, RM 32, RE, SREH, RA 

Note that there might be different mounting positions from one module to another one. The required connection elements and the range of support columns are depicted in the catalogue HT accessories.

Type	CS 16/30	CS 16/60	CS 16/90	CS 16/120
Max. torque $M_x$	10 Nm	14 Nm	14 Nm	14 Nm
Max. torque $M_y$	18 Nm	32 Nm	33 Nm	39 Nm
Max. torque $M_z$	25 Nm	44 Nm	46 Nm	56 Nm
Effective distance $W_x$	51 mm	65 mm	65 mm	72 mm
Effective distance $W_y$	33 mm	33 mm	33 mm	33 mm
Effective distance $W_z$	11 mm	11 mm	11 mm	11 mm

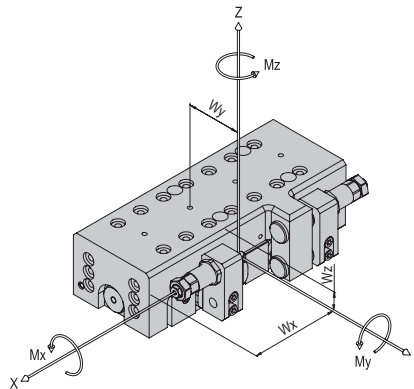

Maximum payload/type	CS 16/30	CS 16/60	CS 16/90	CS 16/120
Installation position (horizontal) for mounting side 1	1.5 kg	2 kg	2 kg	2 kg
Installation position (horizontal) for mounting side 3	2 kg	3 kg	3 kg	3 kg
Installation position (vertical) for mounting side 1	1.5 kg	2 kg	2 kg	2 kg
Installation position (vertical) for mounting side 3	2 kg	3 kg	3 kg	3 kg

Assembly sides  
module mounting

horizontal:

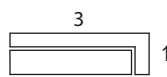

vertical:

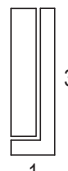

If the specified maximum payloads are exceeded, it must be ensured that the corresponding moments do not affect the service life of the module. All torques are static. In the event of critical applications, please contact Afag.

## Operation time diagrams

CS 16/30

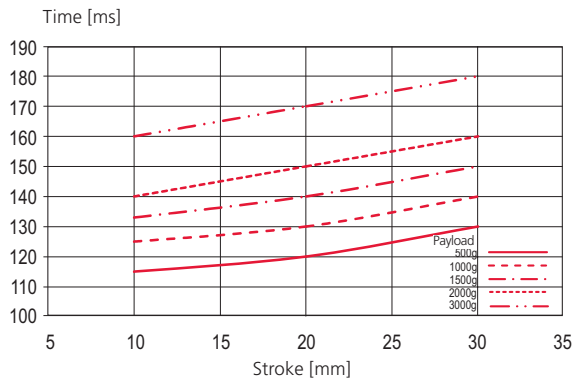

CS 16/60

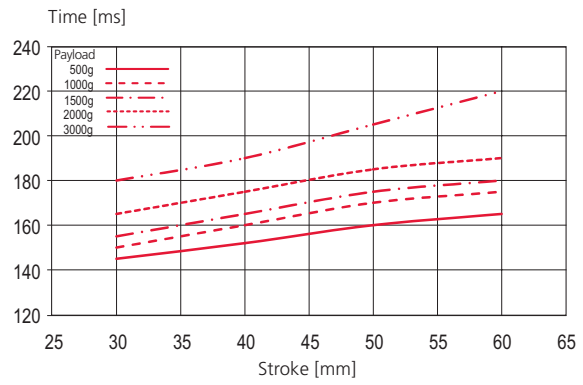

CS 16/90

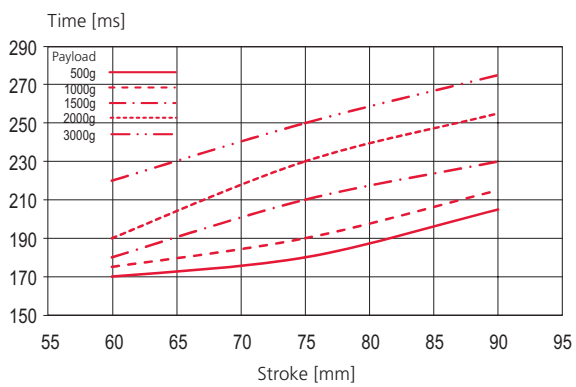

CS 16/120

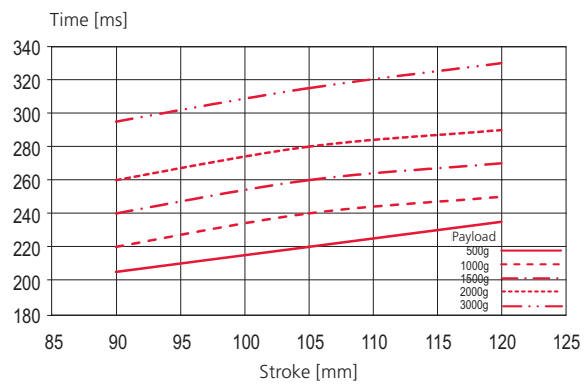

# Compact slides CS

## CS 20

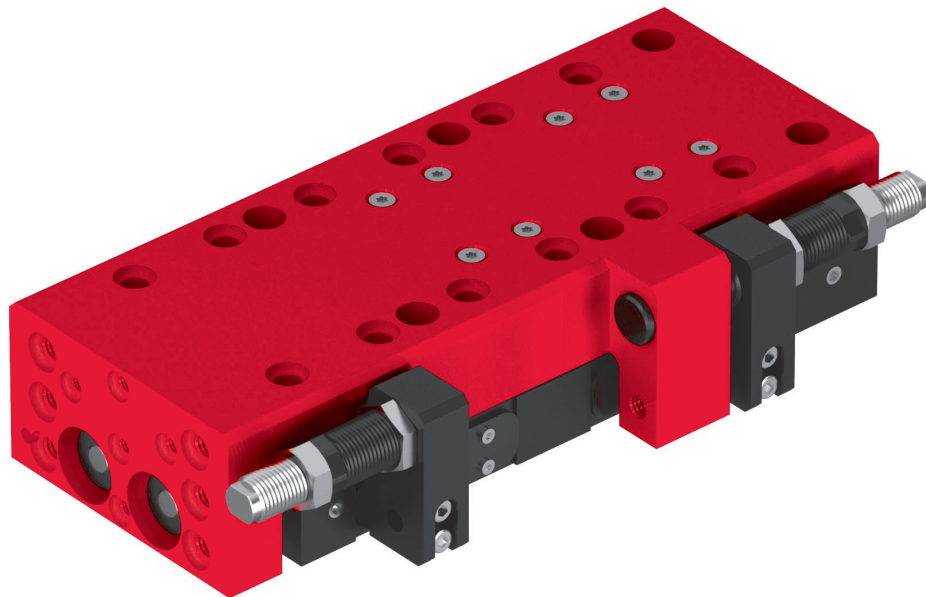

- Compact design
- Solid construction
- High rigidity
- Intermediate stop for 3rd Position



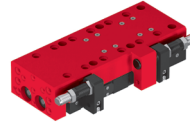

CS 20	
Attachment grid	48 x 48 mm
Attachment thread	M6
Operating pressure	6 +/- 2 bar
Air connection P	M5
Cylinder Ø	2 x 16 mm
Retract piston force	207 N
Extend piston force	241 N
Operating temperature	0 - 50 °C
Storage temperature	0 - 50 °C
Humidity	< 90 %
Medium filtered compressed air	10 - 40 µm

Type	CS 20/50	CS 20/100	CS 20/150
<b>Order number</b>	<b>50100711</b>	<b>50100712</b>	<b>50100713</b>
Stroke H	50 mm	100 mm	150 mm
Stroke limitation	2 x 25 mm	2 x 25 mm	2 x 25 mm
Net weight	1.5 kg	1.8 kg	2.2 kg
Moving weight	0.8 kg	1 kg	1.2 kg
Air consumption/cycle	0.1718 NL	0.3436 NL	0.5154 NL
Noise level	64 dB (A)	64 dB (A)	64 dB (A)
Repeat accuracy	+/- 0.01 mm	+/- 0.01 mm	+/- 0.01 mm
Maximum speed	1 m/s	1 m/s	1 m/s
Minimum speed	0.02 m/s	0.02 m/s	0.02 m/s
Mounting position	✦	✦	✦

The technical data refers to a nominal pressure of 6 bar under Afag standard test conditions. The maximum payloads are listed in the payloads table in the slide loads section. The module can be operated with lubricated or dry air. Cleanroom class ISO 14644-1, class ISO 7

### Included in the delivery (Catalogue HT accessories)

- 2x Centering bushing Ø9x4
- 4x Special screw M6 x 25/9
- 2x Stop sleeve ASH M12x1 -1
- 2x Shock absorber SD M10x1 -5

### Accessories

- Intermediate stop ZA-CS 20 [p. 47]
  - Installation set proximity switch CS 16/CS 20 [p. 48]
- (Catalogue HT accessories)
- INI c10x28.5-Em-PNP-NO-M8x1

### Alternative accessories

- (Catalogue HT accessories)
- INI d4x25-Sn1.0-PNP-NO-M8x1

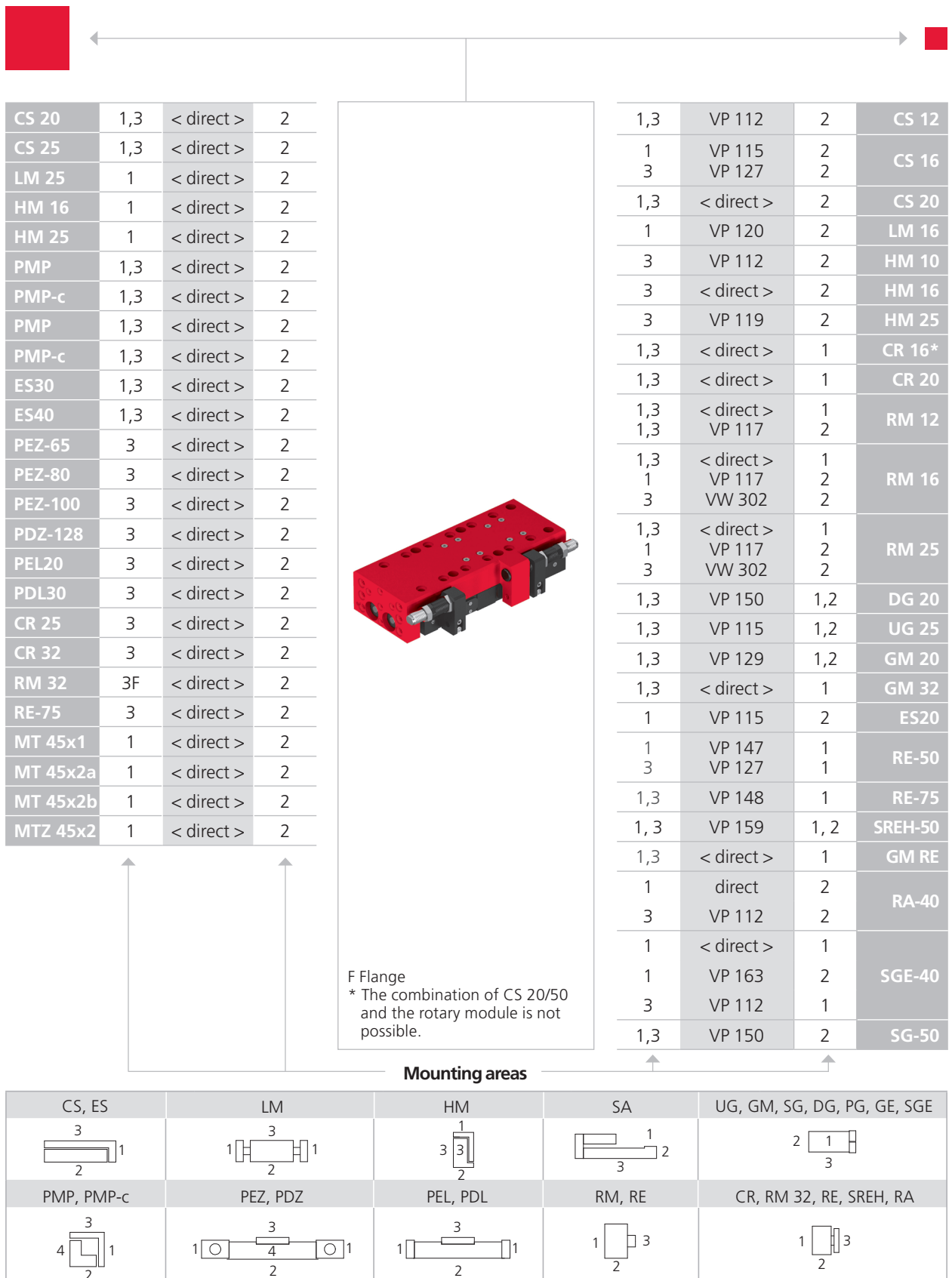

Note that there might be different mounting positions from one module to another one.  
The required connection elements and the range of pedestals are depicted in the catalogue HT accessories.

Type	CS 20/50	CS 20/100	CS 20/150
Max. torque $M_x$	57 Nm	57 Nm	57 Nm
Max. torque $M_y$	50 Nm	57 Nm	63 Nm
Max. torque $M_z$	50 Nm	57 Nm	63 Nm
Effective distance $W_x$	106 mm	163 mm	217 mm
Effective distance $W_y$	43 mm	43 mm	43 mm
Effective distance $W_z$	14 mm	14 mm	14 mm

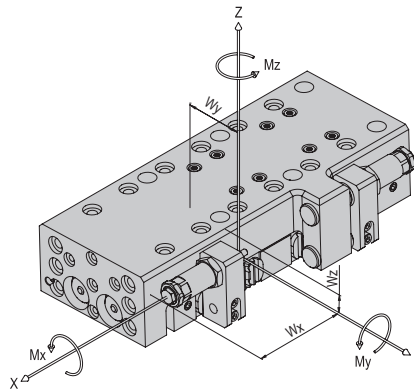

Maximum payload/type	CS 20/50	CS 20/100	CS 20/150
Installation position (horizontal) for mounting side 1	4 kg	4 kg	4 kg
Installation position (horizontal) for mounting side 3	5 kg	5 kg	5 kg
Installation position (vertical) for mounting side 1	4 kg	4 kg	4 kg
Installation position (vertical) for mounting side 3	5 kg	5 kg	5 kg

Assembly sides  
module mounting

horizontal:

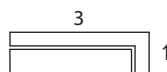

vertical:

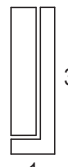

If the specified maximum payloads are exceeded, it must be ensured that the corresponding moments do not affect the service life of the module. All torques are static. In the event of critical applications, please contact Afag.



## Operation time diagrams

CS 20/50

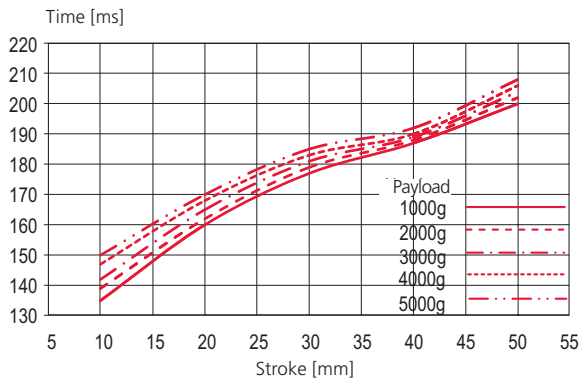

CS 20/100

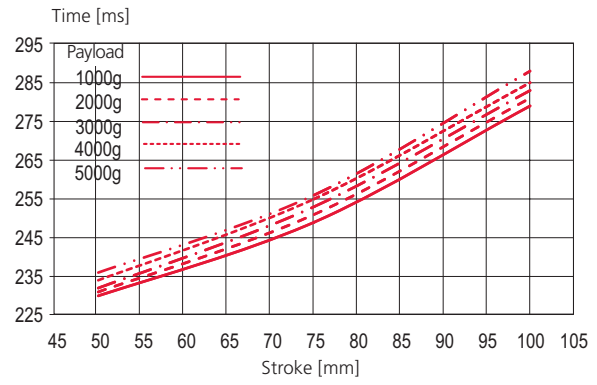

CS 20/150

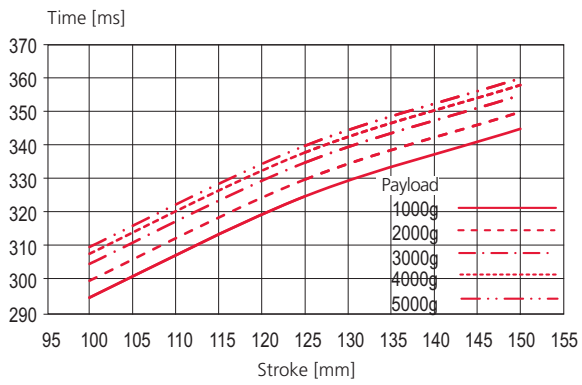

# Compact slides CS

## CS 25

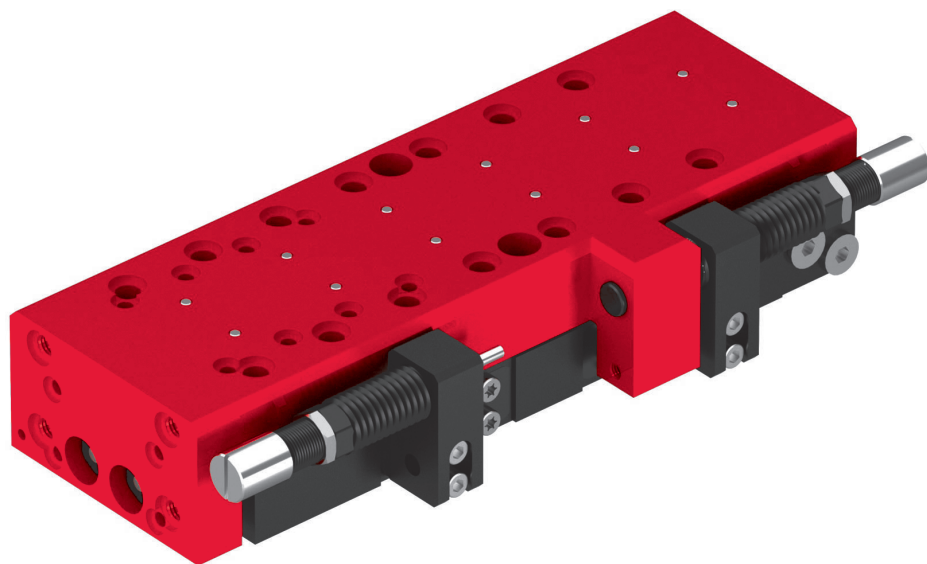

- Compact design
- Solid construction
- High rigidity
- Intermediate stop for 3rd Position

Type	CS 25/60	CS 25/120	CS 25/180	CS 25/240
A	265 mm	325 mm	415 mm	475 mm
B	6 x 30 mm	8 x 30 mm	11 x 30 mm	13 x 30 mm
C	6 x 30 mm	8 x 30 mm	11 x 30 mm	13 x 30 mm

CS 25/240

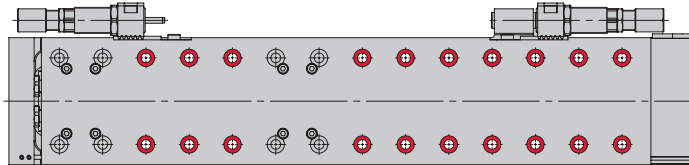

CS 25/180

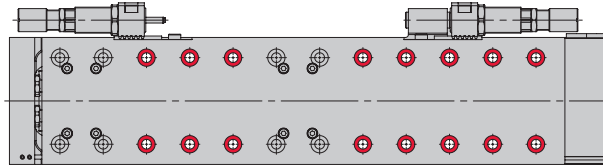

CS 25/120

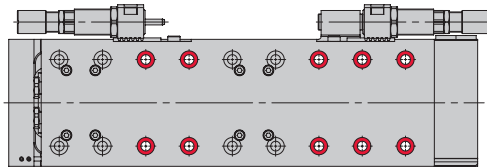

CS 25/60

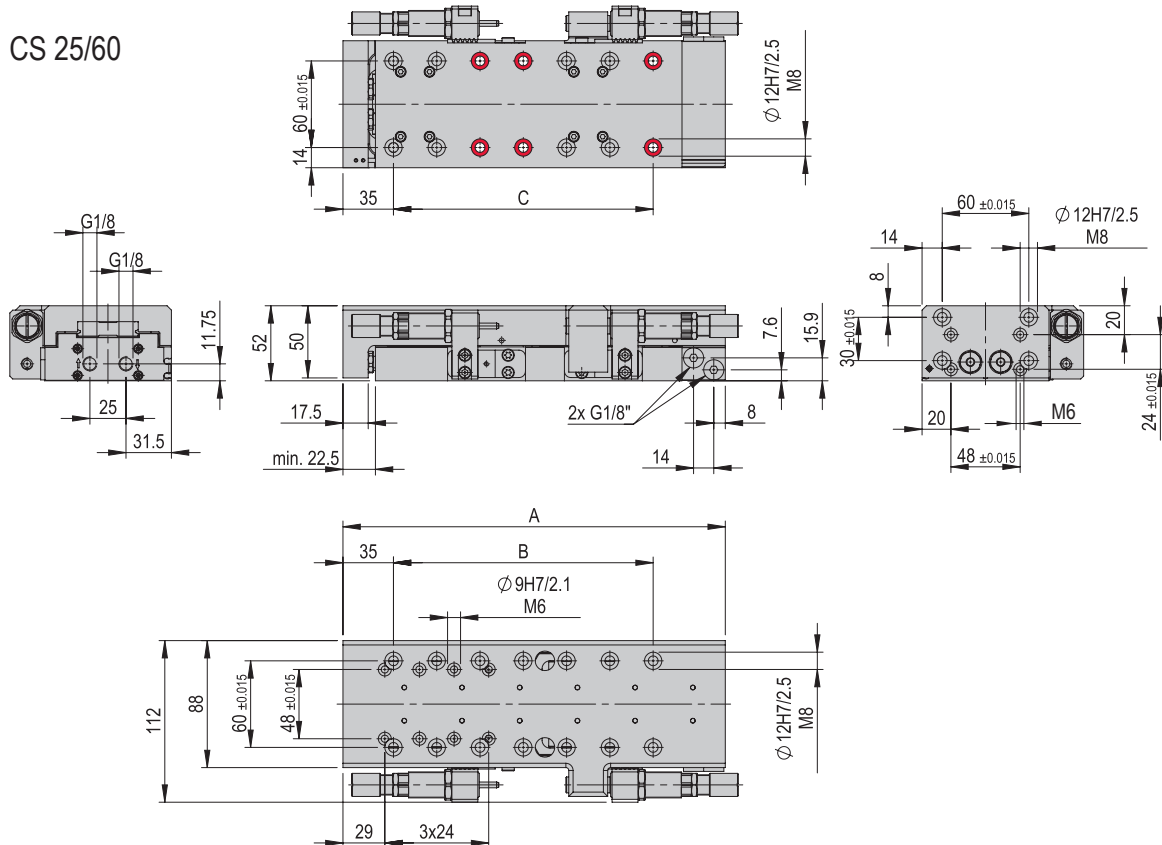

Bores can be screwed through

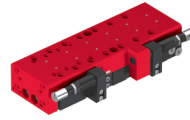

CS 25	
Attachment grid	60 x 60 mm
Attachment grid alternative	48 x 48 mm
Attachment thread	M8
Attachment thread alternative	M6
Operating pressure	6 +/- 2 bar
Air connection P	G1/8 "
Cylinder Ø	2 x 18 mm
Retract piston force	245 N
Extend piston force	305 N
Operating temperature	0 - 50 °C
Storage temperature	0 - 50 °C
Humidity	< 90 %
Medium filtered compressed air	10 - 40 µm

Type	CS 25/60	CS 25/120	CS 25/180	CS 25/240
<b>Order number</b>	<b>50224806</b>	<b>50224807</b>	<b>50224808</b>	<b>50224809</b>
Stroke H	60 mm	120 mm	180 mm	240 mm
Stroke limitation	2 x 30 mm	2 x 30 mm	2 x 30 mm	2 x 30 mm
Net weight	3.935 kg	4.58 kg	5.62 kg	6.26 kg
Moving weight	1.9 kg	2.3 kg	3 kg	3.4 kg
Air consumption/cycle	0.253 NL	0.503 NL	0.759 NL	1.012 NL
Noise level	64 dB (A)	64 dB (A)	64 dB (A)	64 dB (A)
Repeat accuracy	+/- 0.01 mm	+/- 0.01 mm	+/- 0.01 mm	+/- 0.01 mm
Maximum speed	1 m/s	1 m/s	1 m/s	1 m/s
Minimum speed	0.5 m/s	0.5 m/s	0.5 m/s	0.5 m/s
Mounting position	↕	↕	↕	↕

The technical data refers to a nominal pressure of 6 bar under Afag standard test conditions. The maximum payloads are listed in the payloads table in the slide loads section. The module can be operated with lubricated or dry air. Cleanroom class ISO 14644-1, class ISO 7

### Included in the delivery (Catalogue HT accessories)

- 2x Centering bushing Ø12x4.8
- 4x Special screw M8 x 35/15
- 2x Stop sleeve ASH M18x1 -1
- 2x Shock absorber SD M14x1 -2

### Accessories

- Intermediate stop ZA-CS 25 [p. 48]
- Installation set proximity switch CS 25 [p. 48]
- (Catalogue HT accessories)
- INI c10x28.5-Em-PNP-NO-M8x1

### Alternative accessories

- (Catalogue HT accessories)
- INI d6.5x35-Sn1.5-PNP-NO-M8x1

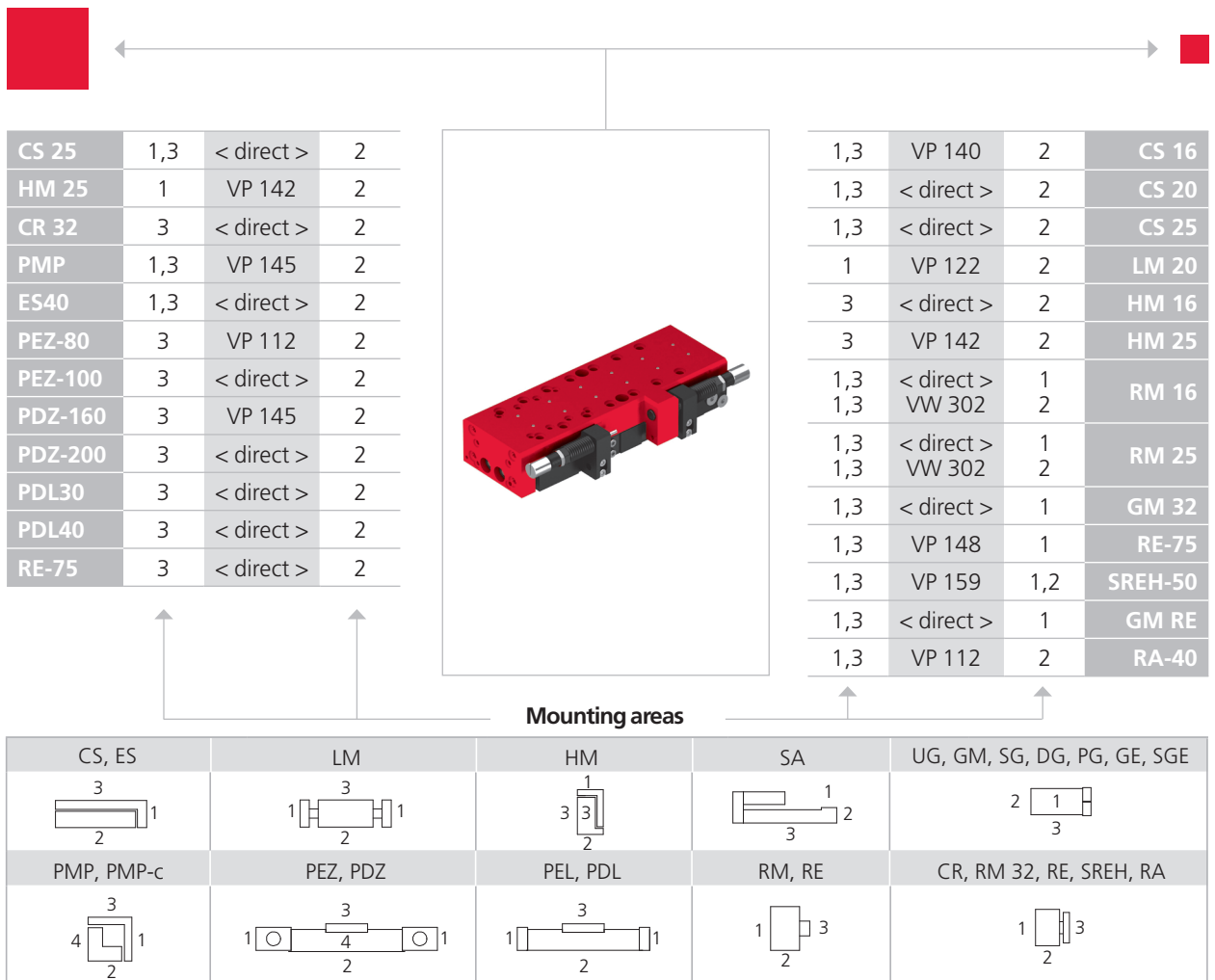

Note that there might be different mounting positions from one module to another one.

The required connection elements and the range of support columns are depicted in the catalogue HT accessories.

Type	CS 25/60	CS 25/120	CS 25/180	CS 25/240
Max. torque Mx	84 Nm	84 Nm	84 Nm	84 Nm
Max. torque My	133 Nm	133 Nm	140 Nm	140 Nm
Max. torque Mz	112 Nm	112 Nm	120 Nm	120 Nm
Effective distance Wx	95 mm	95 mm	95 mm	95 mm
Effective distance Wy	56 mm	56 mm	56 mm	56 mm
Effective distance Wz	14 mm	14 mm	14 mm	14 mm

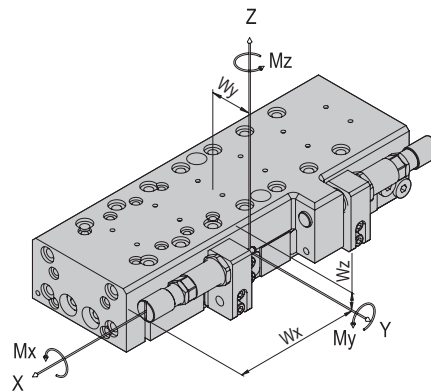

Maximum payload/type	CS 25/60	CS 25/120	CS 25/180	CS 25/240
Installation position (horizontal) for mounting side 1	5 kg	5 kg	5 kg	5 kg
Installation position (horizontal) for mounting side 3	7.5 kg	7.5 kg	7.5 kg	7.5 kg
Installation position (vertical) for mounting side 1	5 kg	5 kg	5 kg	5 kg
Installation position (vertical) for mounting side 3	7.5 kg	7.5 kg	7.5 kg	7.5 kg

Assembly sides  
module mounting

horizontal:

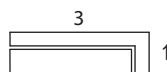

vertical:

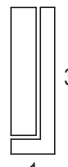

If the specified maximum payloads are exceeded, it must be ensured that the corresponding moments do not affect the service life of the module. All torques are static. In the event of critical applications, please contact Afag.

## Operation time diagrams

CS 25/60

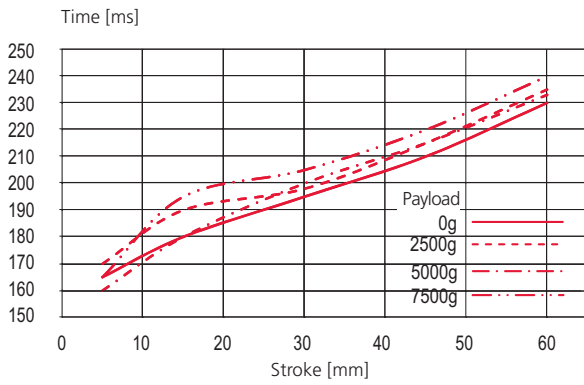

CS 25/120

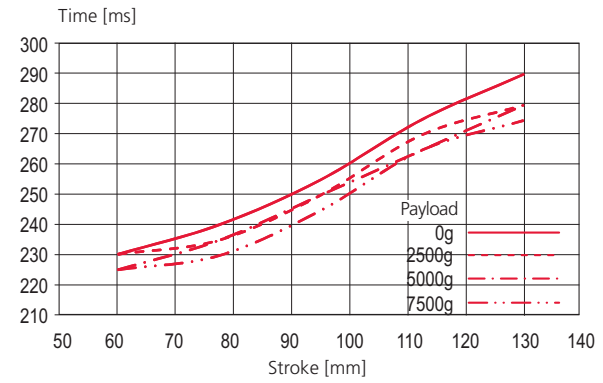

CS 25/180

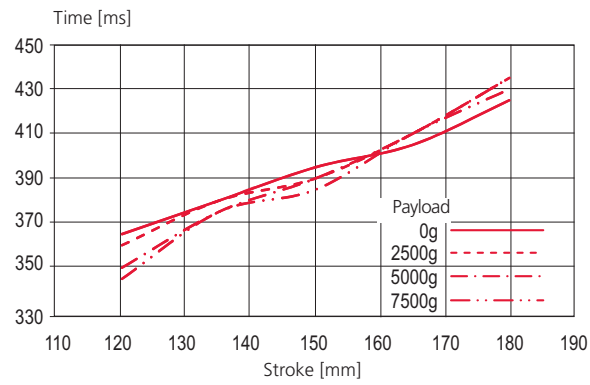

CS 25/240

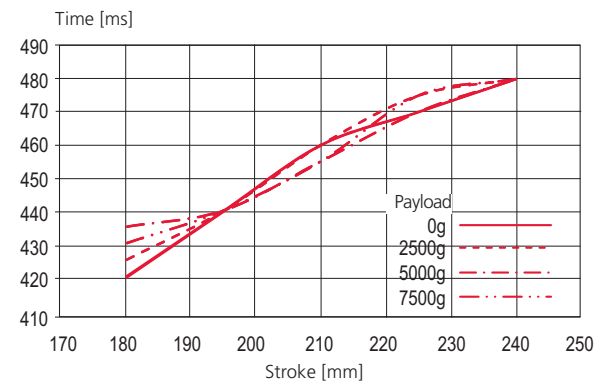

# Accessories CS

Intermediate stop ZA-CS 16	ZA-CS 16
<b>Order number</b>	<b>50205052</b>
Net weight	0.42 kg
P	M5

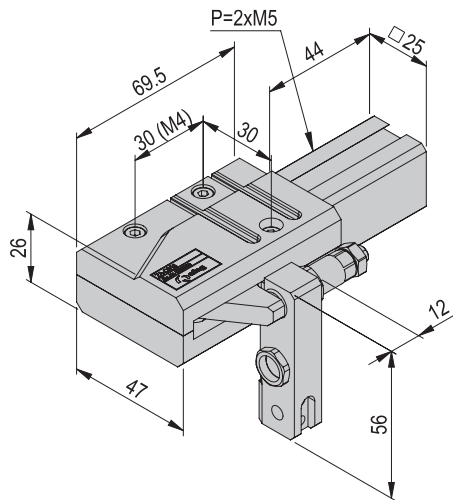

- Included in the delivery**  
(Catalogue HT accessories)
- 3x Centering bushing Ø7x3
  - 3x Mounting screw M4x25
  - 1x Stop sleeve ASH M10x1 -1
  - 1x Shock absorber SD M8x1 -4

- Accessories**  
(Catalogue HT accessories)
- INI c10x28.5-Em-PNP-NO-M8x1

Intermediate stop ZA-CS 20	ZA-CS 20
<b>Order number</b>	<b>50205054</b>
Net weight	0.411 kg
P	M5

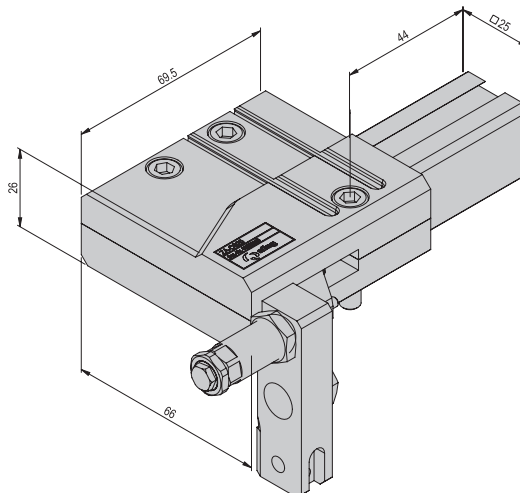

- Included in the delivery**  
(Catalogue HT accessories)
- 3x Centering bushing Ø9x4
  - 3x Mounting screw M6x30
  - 1x Stop sleeve ASH M12x1 -1
  - 1x Shock absorber SD M10x1 -5

- Accessories**  
(Catalogue HT accessories)
- INI d4x25-Sn1.0-PNP-NO-M8x1
  - INI c10x28.5-Em-PNP-NO-M8x1



# Accessories CS

Intermediate stop ZA-CS 25		ZA-CS 25
<b>Order number</b>	<b>50224670</b>	
Net weight	0.816 kg	
P	M5	

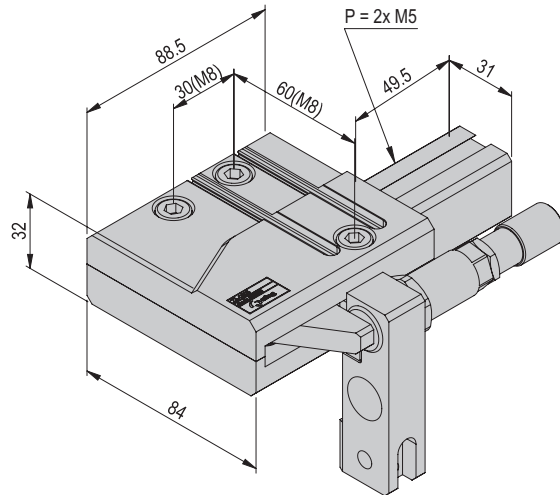

## Included in the delivery

(Catalogue HT accessories)

- 3x Centering bushing  $\varnothing 12 \times 4.8$
- 3x Mounting screw M8x35
- 1x Stop sleeve ASH M18x1 -1
- 1x Shock absorber SD M14x1 -2

## Accessories

(Catalogue HT accessories)

- INI d4x25-Sn1.0-PNP-NO-M8x1
- INI c10x28.5-Em-PNP-NO-M8x1

SDH-fastening 2 part CS 8		50601693
---------------------------	--	----------

<b>Order number</b>	<b>50601693</b>
Net weight	0.01 kg

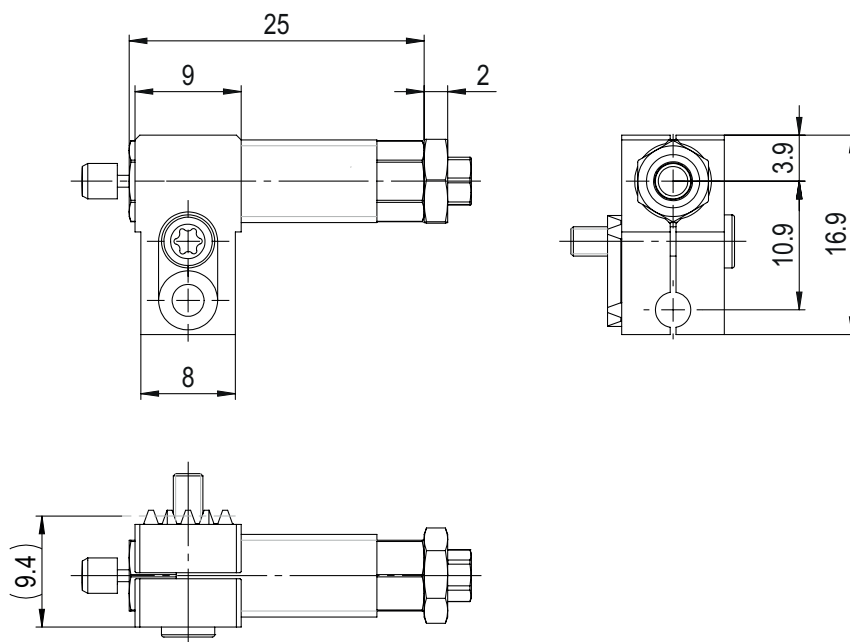

# Accessories CS

## SDH-fastening 2 Part CS 12

<b>Order number</b>	<b>50602745</b>
Net weight	0.02 kg

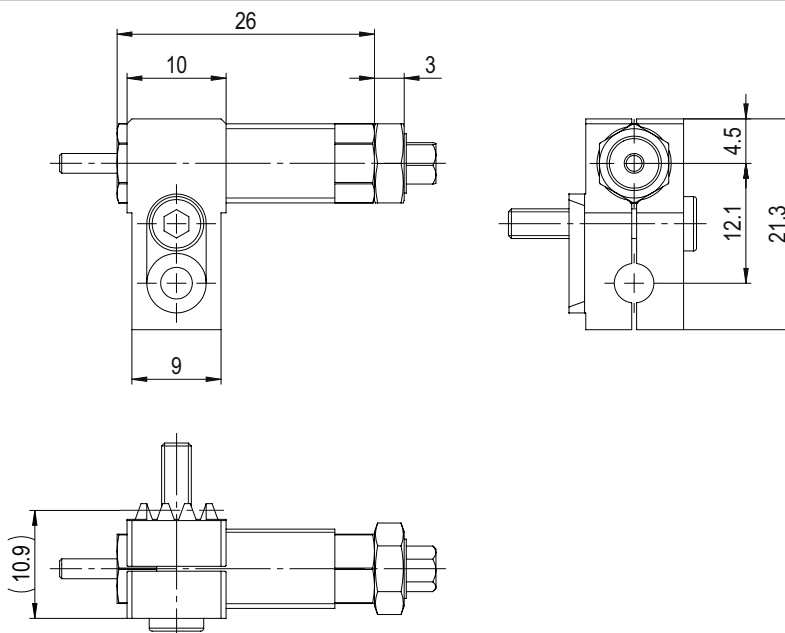

## Installation set inductive switch CS

CS 16/CS 20 CS 25

<b>Order number</b>	<b>50242140</b>	<b>50242141</b>
Net weight	0.001 kg	0.001 kg



Note: Application purpose: See operating manual