



# EMERSON™

## BIRKETT WB SERIES SAFETY RELIEF VALVES

Spring loaded safety relief valves with a full lift and full nozzle to relieve excess pressure safely in a variety of process vessels.



### FEATURES

- Full nozzle, full lift provides high discharge coefficients and high capacities.
- Broad selection of valve types: conventional or bellows for gas or liquid service enables optimum valve selection.
- Wide range of materials provides solutions for any application.
- Lightweight construction reduces handling and shipping costs and benefits offshore service.
- Seat leakage integrity minimizes fugitive emissions.
- Interchangeable parts enable simple modification from gas to liquid and conventional to bellows.
- In-situ testing capability reduces maintenance costs.
- Reduced number of parts minimizes inventory and reduces maintenance costs.
- Valves conform to API 526 pressure/temperature ranges, orifice areas and dimensions.
- Extensive accessory range enables valves to be adapted to meet specific code and application requirements.
- Optional cleaning for cryogenic and oxygen services available.

### GENERAL APPLICATION

The WB Series is designed to relieve excess pressure safely in pumps, pipe work, tanks, calorifiers, gas and oil separators and other process vessels. Models are available for gas, steam, vapor and liquid applications.

### TECHNICAL DATA

Materials:	Carbon steel, stainless steel
Sizes:	1" x 2" to 8" x 10" (DN 25 to 200)
Connections	Flanged ANSI Class 150 to 2500 RF or RTJ
Pressure:	Up to 6000 psig (414 barg)
Temperature range:	-450 to 1000°F (-268 to 538°C)

# BIRKETT WB SERIES SAFETY RELIEF VALVES

## OVERVIEW

---

### MODEL OPTIONS

---

The WB Series is available in four different valve types to suit differing service requirements:

- WB400 - conventional gas type.
- WB300 - bellows gas type.
- WB200 - conventional liquid type.
- WB100 - bellows liquid type.

### CONVENTIONAL SAFETY RELIEF VALVES

---

These valves can be used on systems where the discharge is relatively simple. The pressure in the discharge system can be atmospheric, at a constant level or where it may build up to a maximum of 10% of the set pressure. When a constant back pressure exists, the valve should be set at the differential pressure.

### BELLOWS SAFETY RELIEF VALVES

---

WB Series bellows valves are statically balanced and can be used on more complex discharge systems such as common discharge manifolds and flares where several valves may discharge. These types of system create a variable superimposed back pressure. The balanced bellows unit cancels out the effects of variable back pressure on the valve's set pressure.

#### Gas and vapor service

The gas/vapor disc can be distinguished by a flat underside, unlike the cone profile of the liquid disc.

#### Liquid service

Valves operating on liquid service require a modified design to cope with the differing dynamics of flowing liquids.

A contoured plug disc is used to minimize the initial flow rate, eliminating any potential inlet pressure drops due to excessive valve lift. The valve will simmer until sufficient pressure is available to generate lift. Once this has occurred, the lift will stabilise to suit the flow and pressure conditions required. This avoids the problem of 'chatter'; the rapid opening and closing of the valve which can have a damaging effect on the disc and nozzle causing the valve to leak.

#### Standards and approvals

Quality standard:	ISO 9001:2015
Boiler and pressure vessels:	ASME VIII PED 2014/68/EU
Mechanical Engineering Directive:	ATEX Directive 2014/34/EU
Sizing and selection:	API 520: Part 1 ISO 4126
Dimensions:	API 526
Leakage rates:	API 527
Flange ratings:	ANSI B16.5

TYPICAL LIQUID RELIEF VALVE DISC

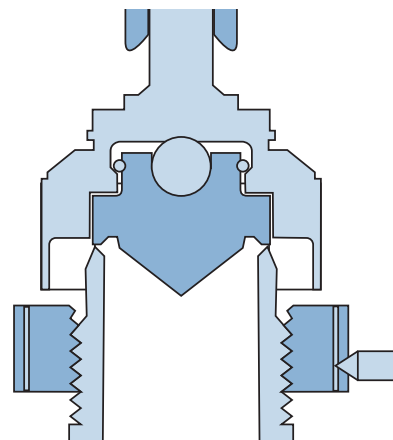

# BIRKETT WB SERIES SAFETY RELIEF VALVES

## FEATURES

---

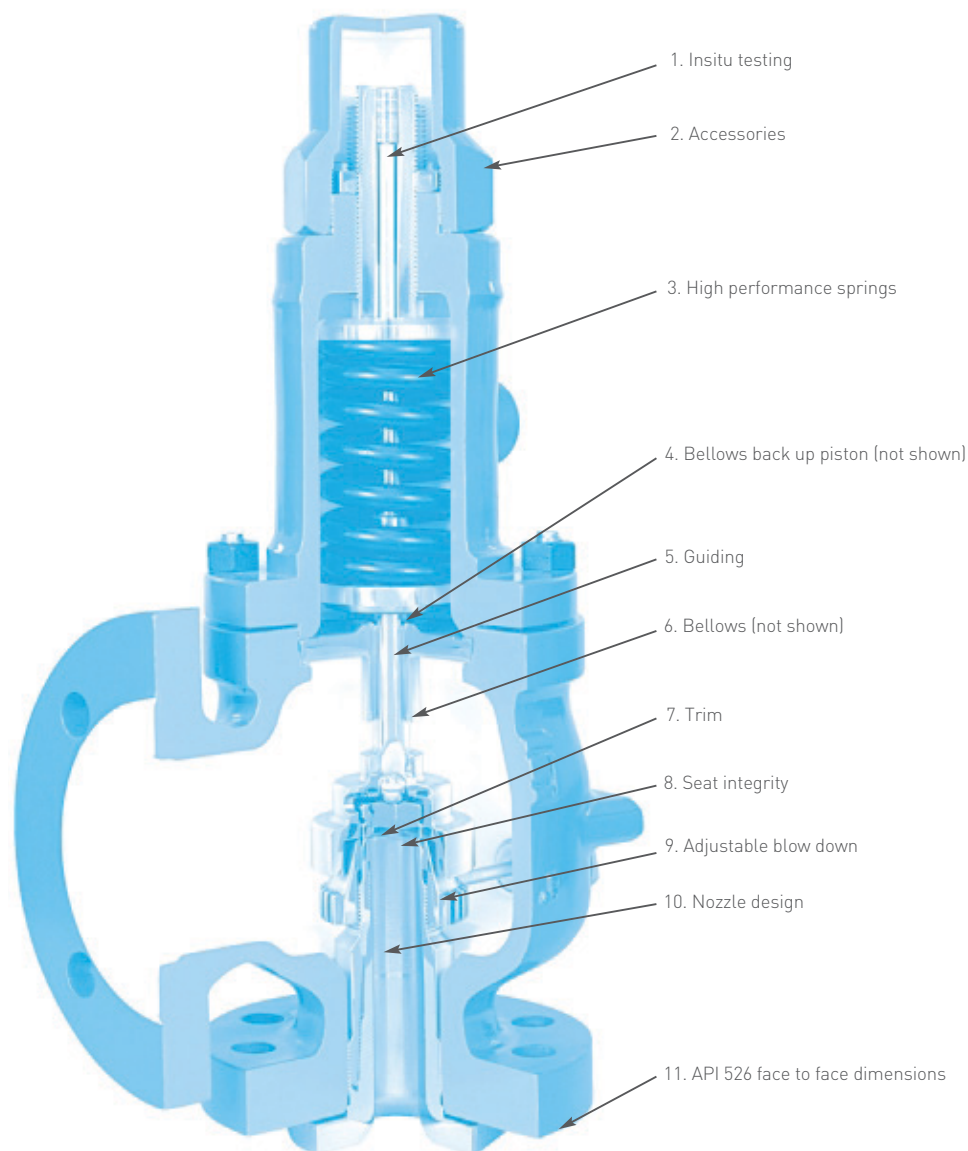

1. Valves can be supplied suitable for application of 'in-situ' set pressure verification devices.
2. Wide accessories range to comply with international codes and suit system requirements.
3. High performance springs designed specifically to guarantee set point repeatability.
4. Optional auxiliary back-up piston for balanced bellows valves ensures fail-safe operation should bellows fail.
5. Guiding components material selection, self aligning disc and spindle pivot point, ensure correct alignment and no galling of guiding surfaces.
6. Bellows ensures correct valve performance under difficult back pressure conditions.
7. Specific gas and liquid trim designs give stable operation and eliminate the damaging effect of chatter.
8. Choice of nozzle and disc materials and superior lapping techniques provides seat tightness to API 527/ASME VIII.
9. Valve reseating pressure (blow down) can be adjusted simply to suit special or specific performance requirements.
10. Carefully located and securely attached nozzle design avoids transmission of pipe stresses to the nozzle/disc mating surfaces.
11. Standardized dimensions to API 526 allow confident pipework layout detailing.

# BIRKETT WB SERIES SAFETY RELIEF VALVES

## OPERATION

### PRINCIPLE OF OPERATION

Safety relief valves use a spring force to hold a disc against a nozzle. Under normal system operating pressure, the valve will remain closed as the spring force is greater than the inlet system pressure force. The valve opens when the system pressure force becomes greater than the closing force of the spring.

The WB Series are designed to have a short simmer, open rapidly to full lift position and then re-seat at a controlled shut off pressure.

This is demonstrated in the graph below, which shows the valve action and corresponding pressure at the valve inlet.

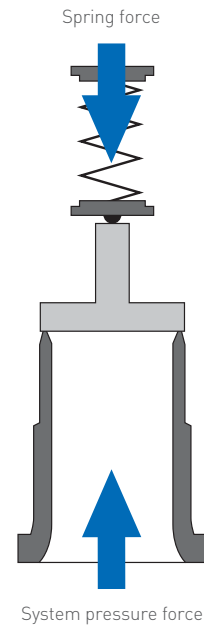

### POPPING AND BLOWDOWN

The difference between the set pressure and the re-seating pressure is known as blowdown. The valve's opening and closing characteristics can be controlled by the adjustment of a blowdown ring, as its position affects the shape and volume of the huddling chamber. When the blowdown ring is adjusted to its top position, the exit area from the huddling chamber is restricted to its minimum. The valve will pop distinctly with a short simmer and long blowdown. When it is in its lowest position there is a maximum exit area from the huddling chamber and the valve will have a longer simmer with a shorter blowdown. The blowdown ring can be positioned between these two extremes to give the required performance but it is usually factory set to achieve re-seating 7-10% below set pressure.

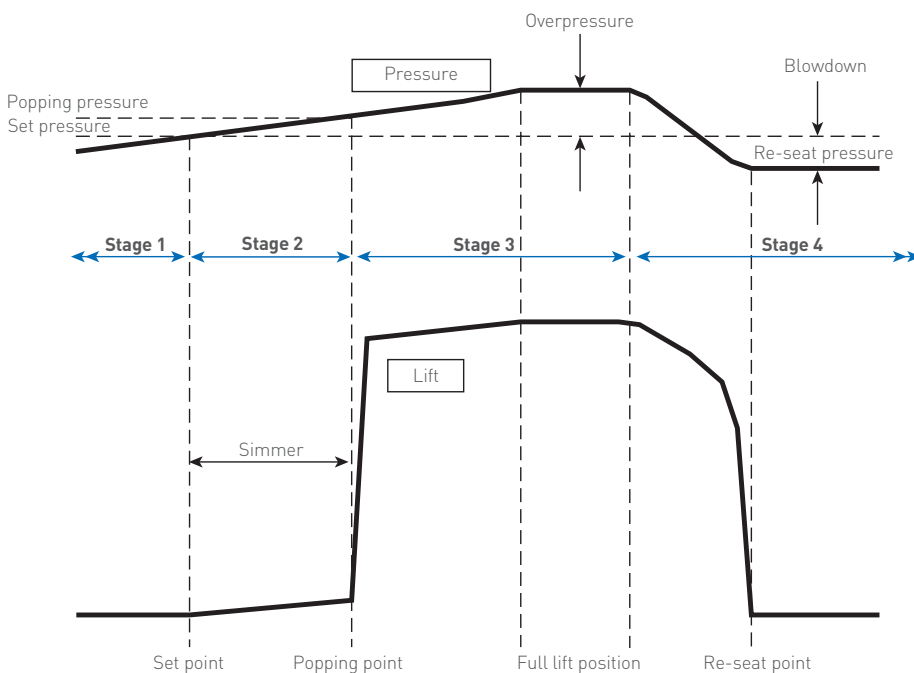

# BIRKETT WB SERIES SAFETY RELIEF VALVES

## OPERATION

### LIFT CYCLE

#### Stage 1 - Closed

Inlet pressure < set pressure

Inlet pressure is below the set pressure. The valve is closed and there is no flow through the valve.

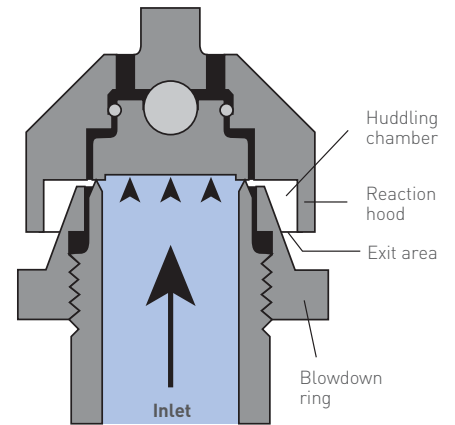

#### Stage 2 - Simmering

Inlet pressure is = > set pressure and < popping pressure

Inlet pressure increases to set pressure. At this point, the spring force and system pressure force are equal; a further rise in inlet pressure will then begin to lift the disc slightly. A small amount of fluid is released into the huddling chamber (the valve simmers). The system fluid is now acting on a larger area inside the huddling chamber.

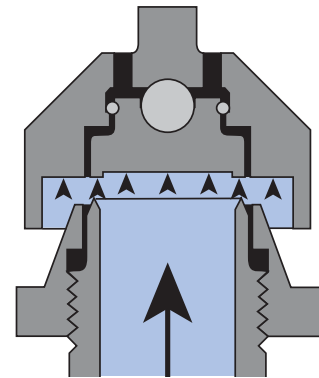

#### Stage 3 - Popping and opening

Inlet pressure = > popping pressure, valve fully open

The inlet pressure acting on a larger area produces a significant force to accelerate the opening. A combination of this pressure force, the kinetic energy from the fluid within the nozzle and the deflection force of the fluid flow turning through the reaction hood is transformed into disc lifting force. The valve pops open at < 5% overpressure and the valve reaches the full open position at 110% of set pressure, in accordance with international codes.

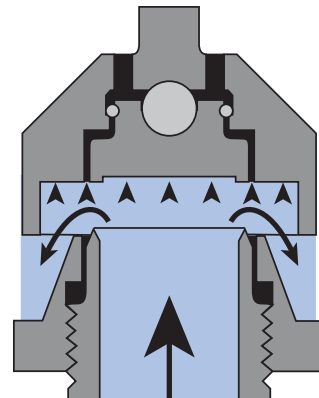

#### Stage 4 - Reseating

Inlet pressure falls to re-seating pressure

As system pressure starts to fall, the force from the spring begins to close the valve. Typically, the system pressure falls between 5-10% below the valve set pressure at which point the spring force accelerates the valve disc to re-seat the valve.

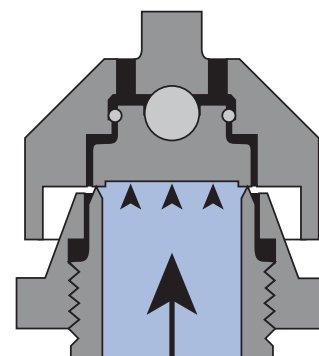

# BIRKETT WB SERIES SAFETY RELIEF VALVES

## OPERATION

### THE EFFECT OF BACK PRESSURE

The configuration of a closed discharge pipework system, typically for toxic or hazardous duty, can generate back pressure. When applied to the valve outlet, this will affect its performance adversely, unless it is addressed.

Back pressure can take three forms:

1. Superimposed constant back pressure  
This exists permanently and a conventional or bellows valve can be used. A conventional valve can be set at the differential pressure so that the spring load is adjusted to take account of the back pressure.
2. Built up back pressure  
This is created by the configuration of discharge pipework systems and varies from zero when the valve is closed, to a maximum, when fully open. Conventional spring loaded valves can tolerate up to 10% of set pressure as built up back pressure. For back pressures in excess of 10%, a balanced bellows design is required to maintain valve lift.
3. Superimposed variable back pressure  
This is caused by other valves discharging into a common disposal system or other circumstances that cause the back pressure to be variable. Balanced bellows valves should be used for this condition, adjusted to the predetermined set pressure.

### CONSTANT BACK PRESSURE - CONVENTIONAL VALVE

Spring load (differential pressure) 150 lbf/in<sup>2</sup> (10.3 bar)

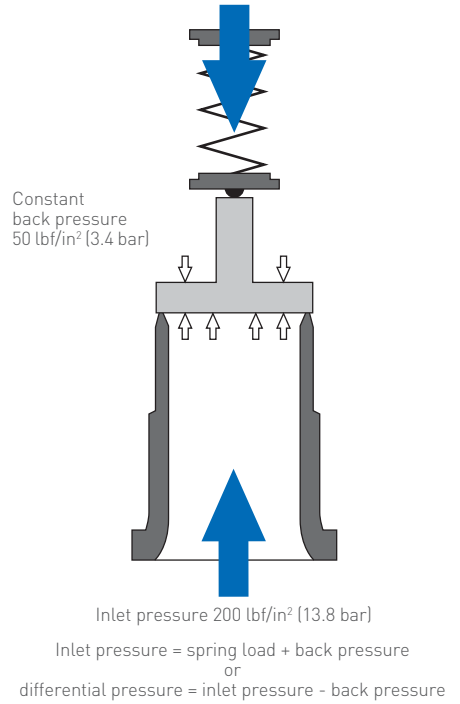

### VARIABLE BACK PRESSURE - BALANCED BELLOWS VALVE

Spring load (set pressure) 200 lbf/in<sup>2</sup> (13.8 bar)

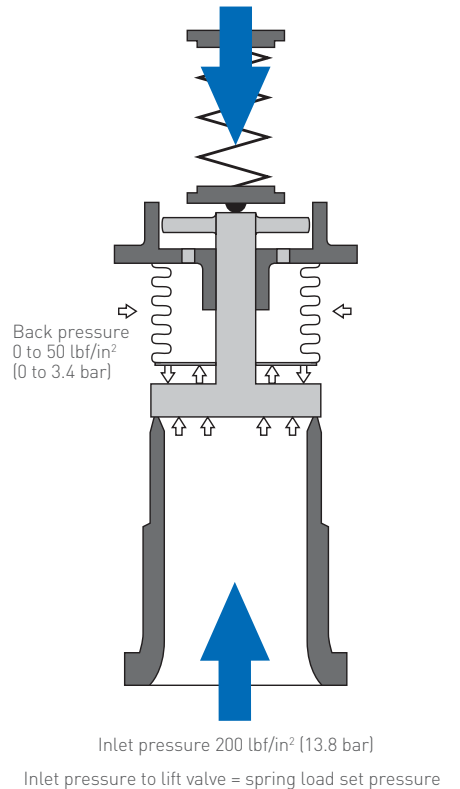

# BIRKETT WB SERIES SAFETY RELIEF VALVES

## MATERIALS OF CONSTRUCTION

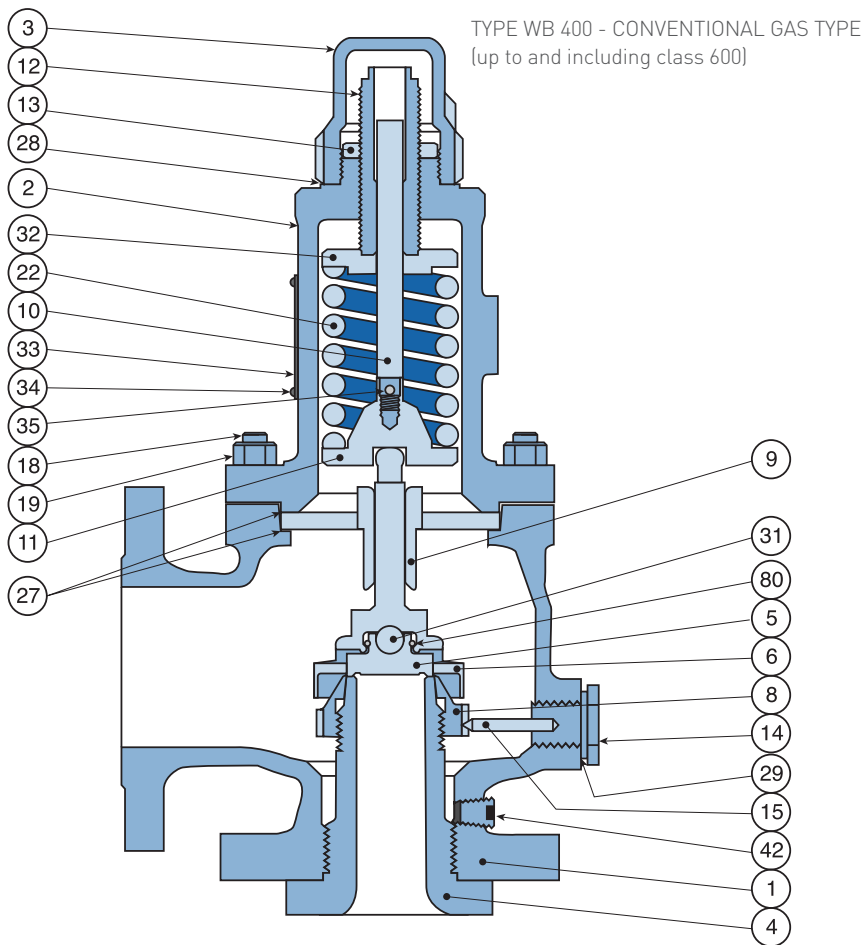

### PARTS LIST

Item	Part	Carbon steel	Stainless steel
1	Body	SA 216-WCB Carbon steel	SA 351-CF8M SST
2	Casing	SA 216-WCB Carbon steel	SA 351-CF8M SST
3	Cap	SA 216-WCB Carbon steel	SA 351-CF8M SST
4*	Nozzle	316 SST	316 SST
5*	Disc	316 SST	316 SST
6*	Disc holder	ASTM A479-316L	ASTM A479-316L
8	Blowdown ring	SA 351-CF8M SST	SA 351-CF8M SST
9	Guide assy	Carbon Steel /17-4 SST	316L/17-4 SST
10*	Spindle	ASTM A479-431	ASTM A479-431
11	Lower spring plate	ASTM A108-1021/Ni PLT	ASTM A479-431
12	Adjusting screw	ASTM A479-410	ASTM A479-410
13	Locking nut	ASTM A108-1021	ASTM A479-316L
14	Setting screw	ASTM A479-431	ASTM A479-431
15	Setting screw rod	ASTM A479-316L	ASTM A479-316L
18	Stud	SA 193-B7 CR/MOL ST	SA 193-B8T SST
19	Nut	SA 194-2H Carbon steel	SA 194-8T SST
22*	Spring	Carbon steel	ASTM A313-316
27*	Body gasket	ST-706	ST-706
28*	Cap gasket	ST-706	ST-706
29*	Set screw gasket	ST-706	ST-706
31*	Ball	AISI 440C SST	AISI 440C SST
32	Upper spring plate	ASTM A108-1021/Ni PLT	ASTM A479-431
33	Data plate	321 SST	321 SST
34	Hammer drive screw	Electro brassed ST	ASTM A479-316L
35	Grooved pin	ASTM A479-431	ASTM A479-431
42	Drain plug	HTS HOLO-KROME	ASTM A479-316L
80*	Circlip	ASTM A313-316	ASTM A313-316

\* Recommended spares

# BIRKETT WB SERIES SAFETY RELIEF VALVES

## MATERIALS OF CONSTRUCTION

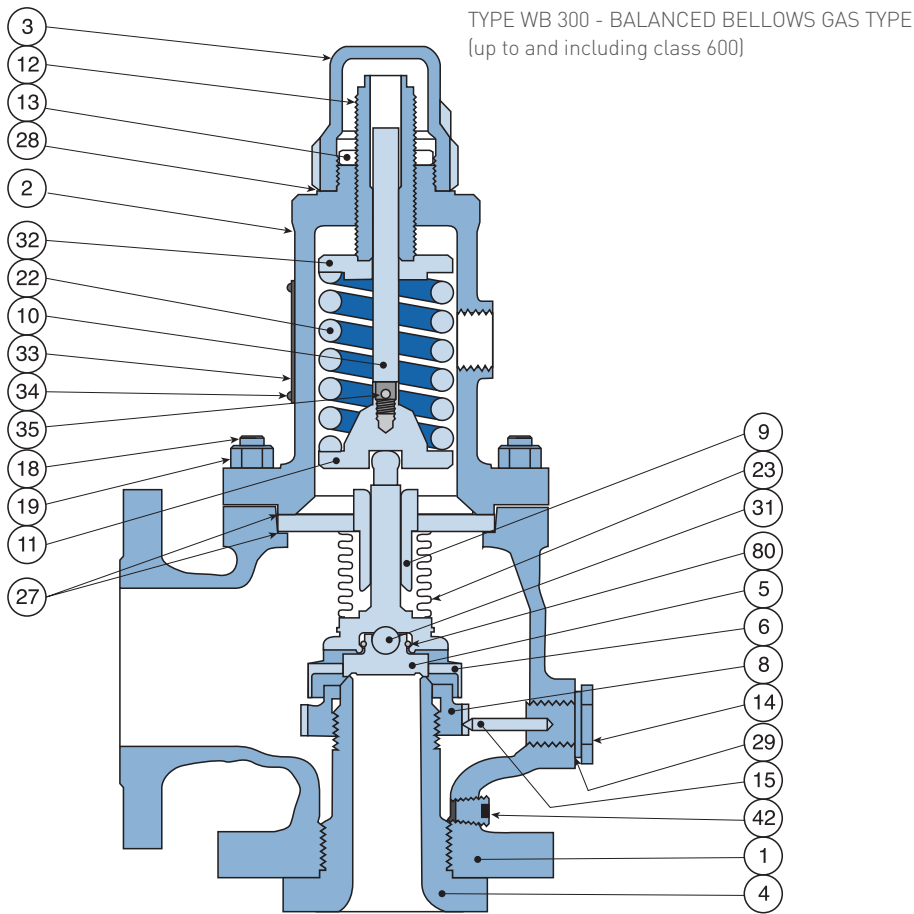

### PARTS LIST

Item	Part	Carbon steel	Stainless steel
1	Body	SA 216-WCB Carbon steel	SA 351-CF8M SST
2	Casing	SA 216-WCB Carbon steel	SA 351-CF8M SST
3	Cap	SA 216-WCB Carbon steel	SA 351-CF8M SST
4*	Nozzle	316 SST	316 SST
5*	Disc	316 SST	316 SST
6*	Disc holder	Included in item 23	Included in item 23
8	Blowdown ring	SA 351-CF8M SST	SA 351-CF8M SST
9	Guide Assy	CARBON ST/17-4 SST	316 L/17-4 SST
10*	Spindle	ASTM A479-431	ASTM A479-431
11	Lower spring plate	ASTM A108-1021/Ni PLT	ASTM A479-431
12	Adjusting screw	ASTM A479-410	ASTM A479-410
13	Locking nut	ASTM A108-1021	ASTM A479-316L
14	Setting screw	ASTM A479-431	ASTM A479-431
15	Set screw rod	ASTM A479-316L	ASTM A479-316L
18	Stud	SA 193-B7 CR/MOL ST	SA 193-B8T SST
19	Nut	SA 194-2H Carbon steel	SA 194-8T SST
22*	Spring	Carbon steel	ASTM A313-316
23*	Bellows assembly	ASTM A479-316L/SA240-316L	ASTM A479-316L/SA240-316L
27*	Body gasket	ST-706	ST-706
28*	Cap gasket	ST-706	ST-706
29*	Set screw gasket	ST-706	ST-706
31*	Ball	AISI 440C SST	AISI 440C SST
32	Upper spring plate	ASTM A108-1021/Ni PLT	ASTM A479 431
33	Data plate	321 SST	321 SST
34	Hammer drive screw	Electro brassed ST	ASTM A479-316L
35	Grooved pin	ASTM A479-431	ASTM A479-431
42	Drain plug	HTS holo-krome	ASTM A479-316L
80*	Circlip	ASTM A313-316	ASTM A313-316

\* Recommended spares



# BIRKETT WB SERIES SAFETY RELIEF VALVES

## MATERIALS OF CONSTRUCTION

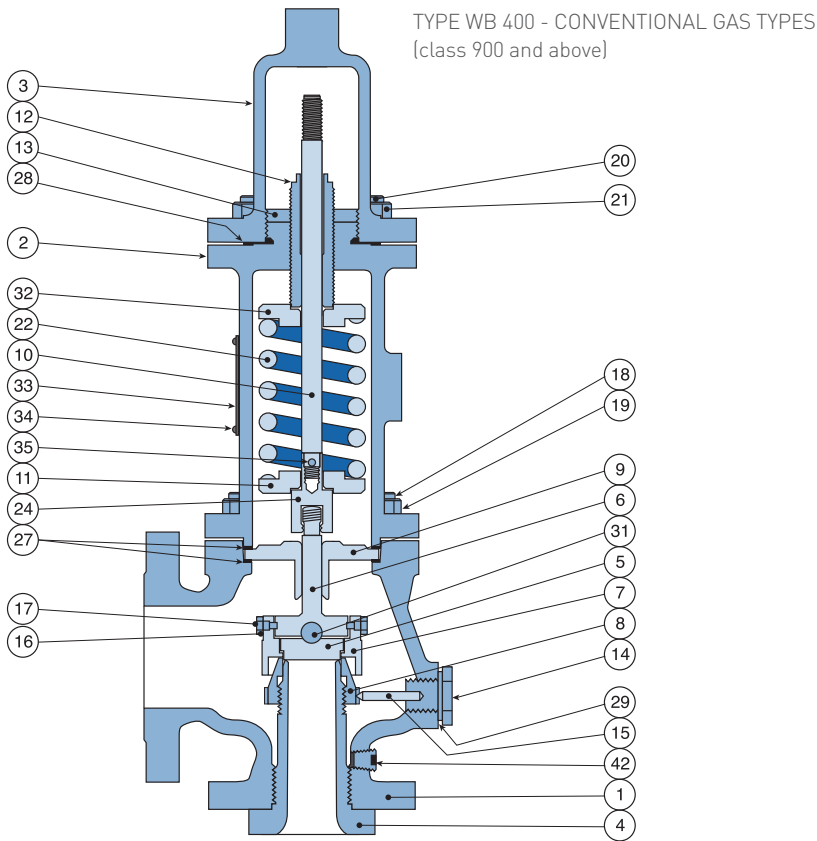

### PARTS LIST

Item	Part	Carbon steel	Stainless steel
1	Body	SA 216-WCB Carbon steel	SA 351-CF8M SST
2	Casing	SA 216-WCB Carbon steel	SA 351-CF8M SST
3	Cap	SA 216-WCB Carbon steel	SA 351-CF8M SST
4*	Nozzle	316 SST	316 SST
5*	Disc	316 SST	316 SST
6*	Disc holder	ASTM A479-316L	ASTM A479-316L
7	Reaction hood	ASTM A479-431	ASTM A479-431
8	Blowdown ring	SA 351-CF8M SST	SA 351-CF8M SST
9	Guide plate	17-4 SST	17-4 SST
10*	Spindle	ASTM A479-431	ASTM A479-431
11	Lower spring cap	ASTM A108-1021/Ni PLT	ASTM A479-431
12	Adjusting screw	ASTM A479-410	ASTM A479-410
13	Locking nut	ASTM A108-1021	ASTM A479-316L
14	Setting screw	ASTM A479-431	ASTM A479-431
15	Setting screw rod	ASTM A479-316L	ASTM A479-316L
16*	Tabwasher	BS 1449-304S15 SST	BS 1449-304S15 SST
17*	Pinning screw	ASTM A479-431	ASTM A479-431
18	Body stud	SA 193-B7 CR/MOL ST	SA 193-B8T SST
19	Body nut	SA 194-2H Carbon steel	SA 194-8T SST
20	Casing stud	SA 193-B7 CR/MOL ST	SA 193-B8T SST
21	Casing nut	SA 194-2H Carbon steel	SA 194-8T SST
22*	Spring	Carbon steel	ASTM A313-316
24*	Spindle head	ASTM A479-431	ASTM A479-431
27*	Body gasket	ST-706	ST-706
28*	Cap gasket	ST-706	ST-706
29*	Setting screw gasket	ST-706	ST-706
31*	Ball	AISI 440C SST	AISI 440C SST
32	Upper spring cap	ASTM A108-1021/Ni PLT	ASTM A479-431
33	Data plate	321 SST	321 SST
34	Hammer drive screw	Electro brass ST	ASTM A479-316L
35*	Grooved pin	ASTM A479-431	ASTM A479-431
42	Drain plug	HTS holo-krome	ASTM A479-316L

\* Recommended spares

# BIRKETT WB SERIES SAFETY RELIEF VALVES

## MATERIALS OF CONSTRUCTION

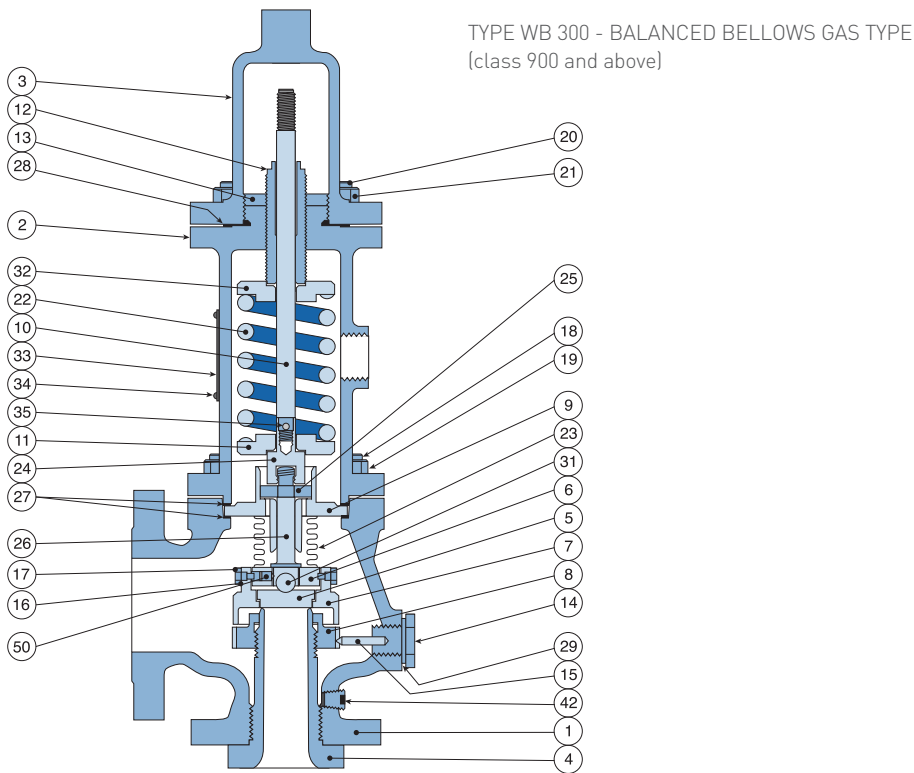

### PARTS LIST

Item	Part	Carbon steel	Stainless steel
1	Body	SA 216-WCB Carbon steel	SA 351-CF8M SST
2	Casing	SA 216-WCB Carbon steel	SA 351-CF8M SST
3	Cap	SA 216-WCB Carbon steel	SA 351-CF8M SST
4*	Nozzle	316 SST	316 SST
5*	Disc	316 SST	316 SST
6*	Disc holder base	ASTM A479-321	ASTM A479-321
7	Reaction hood	ASTM A479-431	ASTM A479-431
8	Blowdown ring	SA 351-CF8M SST	SA 351-CF8M SST
9	Guide plate	17-4 SST	17-4 SST
10*	Spindle	ASTM A479-431	ASTM A479-431
11	Lower spring cap	ASTM A108-1021/Ni PLT	ASTM A479-431
12	Adjusting screw	ASTM A479-410	ASTM A479-410
13	Locking nut	ASTM A108-1021	ASTM A479-316L
14	Setting screw	ASTM A479-431	ASTM A479-431
15	Setting screw rod	ASTM A479-316L	ASTM A479-316L
16*	Tabwasher	BS 1449-304S15 SST	BS 1449-304S15 SST
17*	Pinning screw	ASTM A479-431	ASTM A479-431
18	Body stud	SA 193-B7 CR/MOL ST	SA 193-B8T SST
19	Body nut	SA 194-2H Carbon steel	SA 194-8T SST
20	Casing stud	SA 193-B7 CR/MOL ST	SA 193-B8T SST
21	Casing nut	SA 194-2H Carbon steel	SA 194-8T SST
22*	Spring	Carbon steel	ASTM A313-316
23*	Bellows	SA 240-316L	SA 240-316L
24*	Spindle head	ASTM A479-431	ASTM A479-431
25	Piston	ASTM A479-431	ASTM A479-431
26	Guide spindle	ASTM A479-321	ASTM A479-3431
27*	Body gasket	ST-706	ST-706
28	Cap gasket	ST-706	ST-706
29	Setting screw gasket	ST-706	ST-706
31	Ball	AISI 440C SST	AISI 440C SST
32	Upper spring cap	ASTM A108-1021/Ni PLT	ASTM A479 431
33	Data plate	321 SST	321 SST
34	Hammer drive screw	ELECTRO BRASSED ST	ASTM A479-316L
35	Grooved pin	ASTM A479-431	ASTM A479-431
42	Drain plug	HTS HOLO-KROME	ASTM A479-316L
50	Grubscrew	ASTM A479-321	ASTM A479-321

\* Recommended spares

# BIRKETT WB SERIES SAFETY RELIEF VALVES

## ACCESSORIES

### SCREWED CAP

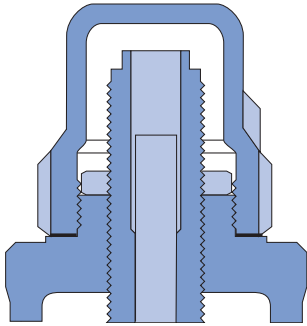

#### Screwed cap

This is the standard option on all valves.

### BOLTED CAP

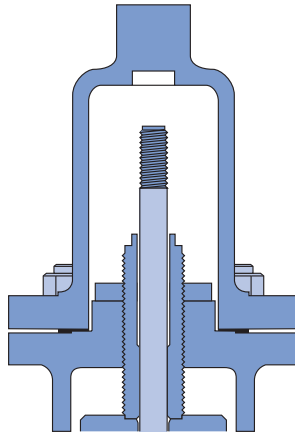

#### Bolted cap

Option available as required or for critical service where fragile gasket materials may be fitted.

### OPEN LEVER

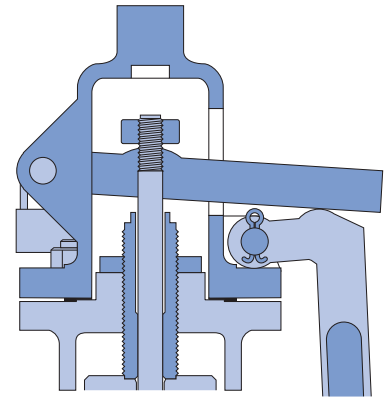

#### Open lever<sup>1</sup>

The open lever assembly is not pressure tight and therefore is only suitable where vapor can be allowed to escape safely to atmosphere.

### PACKED LEVER

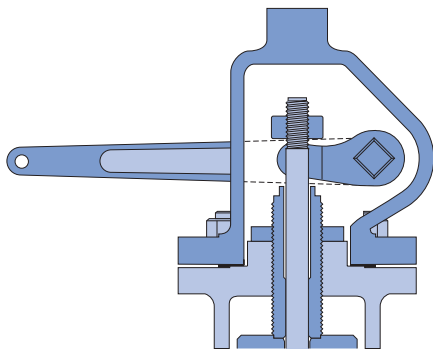

#### Packed lever<sup>1</sup>

The design of the packed lever assembly ensures that leakage does not occur when the valve is open or when back pressure is present.

### TEST GAG

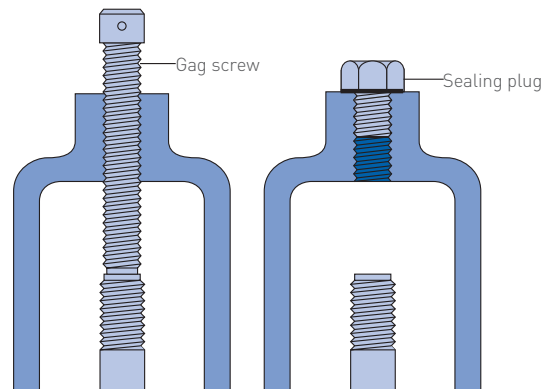

#### Test gag

The test gag is used to prevent the safety valve from lifting and is used mainly when carrying out a hydrostatic test on the system, during commissioning.

After testing, the test gag must be removed and replaced with the sealing plug.

1. A lift lever can be used to test for correct valve operation where corrosion or deposits could prevent the valve from opening. It can be used to release foreign particles trapped on the seat and must be fitted when codes dictate.

# BIRKETT WB SERIES SAFETY RELIEF VALVES

## ACCESSORIES

### FERRULE

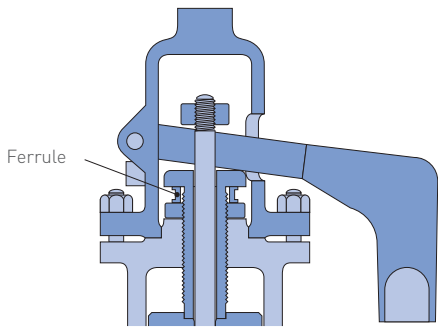

#### Ferrule (government ring)

A ferrule, sometimes known as a government ring, is a collar fitted beneath the head of the pressure adjusting screw. Some authorities will require a ferrule to be fitted to prevent unauthorized interference with the set pressure.

### SOFT SEAT

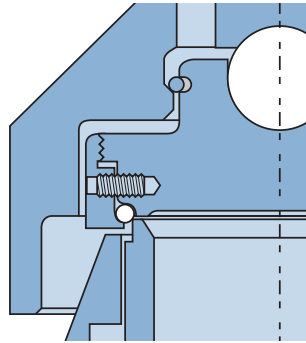

#### Soft seat

An O-ring seal offers maximum seat tightness, over and above that of the standard metal-to-metal seats. A wide range of seal materials is available including Fluorocarbon (FKM), Nitrile (NBR), Kalrez® and Polytetrafluoroethylene (PTFE).

Specify a soft seat for high integrity seat leakage.

### STEAM JACKET



#### Steam jacket

Some process media can solidify or form crystals if they cool within the system. The medium within the valve nozzle is not in the flow path and therefore can cool. The valve may not lift should the medium solidify, crystallise or if sublimation of vapor was to occur within the nozzle.

The steam jacket is designed to keep the process medium hot, helping to maximize plant safety. It has both an inlet and outlet so that low pressure steam can be passed through the jacket, keeping the valve hot. This allows the valve to stay operational, enabling it to relieve pressure successfully should an overpressure situation occur.

The steam jacket is manufactured from material that is compatible with the valve body and the connections to the jacket can be either flanged or screwed.

### AUXILIARY BACK-UP PISTON

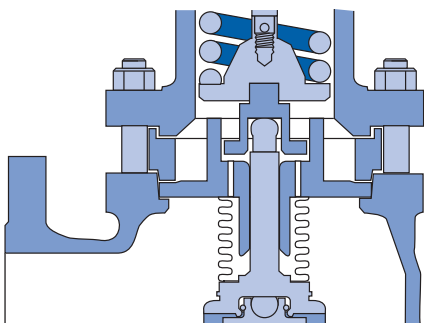

#### Auxiliary back-up piston

A potentially dangerous situation can arise if the bellows fails. The back pressure causes an 'out-of-balance' condition which may cause:

1. Increase in set pressure.
2. Decrease in flow capacity.
3. Increase in re-seat pressure.

Specifying bellows valves with an auxiliary back-up piston ensures these do not occur. The piston has the same effective diameter as the failed bellows, so any effect of the back pressure increasing the set pressure is counteracted by an upward thrust of the piston. The Type WB 300 valve incorporates the auxiliary back-up piston as standard in all pressure classes 900 and above and as an optional feature for class 600 and below.

Specify the auxiliary back-up piston to ensure absolute safety.

# BIRKETT WB SERIES SAFETY RELIEF VALVES

## SELECTION

### SELECTION GUIDE

Example:	4	L	6	H	1	2	1	1	1	2	B
<b>Model</b>											
1 1"	4										
1.5 1½"	6										
2 2"	8										
3 3"											
<b>Orifice designation</b>											
<b>D to T</b>											
<b>Outlet diameter</b>											
2 2"	6										
3 3"	8										
4 4"	10										
<b>Design</b>											
H ANSI 150, 300 and 600											
/ ANSI 900, 1500 and 2500											
<b>Valve type</b>											
1 Liquid bellows											
2 Liquid conventional											
3 Vapor bellows											
4 Vapor conventional											
<b>ANSI flange rating (inlet x outlet)</b>											
1 150 x 150	5										
2 300 x 150	6										
3 600 x 150	7										
4 900 x 150	8										
0 Special											
<b>Flange face</b>											
1 ANSI RF x RF											
2 ANSI RTJ inlet x RF											
0 Special											
<b>Body material</b>											
1 Carbon steel WCB	5										
2 Carbon steel WCB NACE	6										
3 Stainless steel CF8M NACE	8										
4 Stainless steel CF8M	9										
0 Special											
<b>Spring material</b>											
1 Carbon steel	A										
2 Stainless steel 316	N										
6 Tungsten alloy	Q										
9 Hastelloy B	T										
0 Special	Z										
<b>Trim material nozzle and disc</b>											
1 Stainless steel PH 17/4	5										
2 Stainless steel 316	6										
3 Aluminum bronze / Monel®	7										
4 Hastelloy® B	0										
<b>Accessories</b>											
B Auxiliary back-up piston	M										
C Bolted cap	P										
D Screwed cap	R										
F Ferrule (Government ring)	S										
G Test gag	3										
H <sup>(1)</sup> High pressure											

1. In some instances when both high pressures and alloy springs are required, the 'H' needs adding to accessories.

VCTDS-03791-EN © 2017, 2023 Emerson Electric Co. All rights reserved 09/23. Birkett is a mark owned by one of the companies in the Emerson Automation Solutions business unit of Emerson Electric Co. The Emerson logo is a trademark and service mark of Emerson Electric Co. All other marks are property of their respective owners.

The contents of this publication are presented for informational purposes only, and while effort has been made to ensure their accuracy, they are not to be construed as warranties or guarantees, express or implied, regarding the products or services described herein or their use or applicability. All sales are governed by our terms and conditions, which are available on request. We reserve the right to modify or improve the designs or specifications of our products at any time without notice.

Emerson Electric Co. does not assume responsibility for the selection, use or maintenance of any product. Responsibility for proper selection, use and maintenance of any Emerson Electric Co. product remains solely with the purchaser.

Emerson.com