



**KTM SERIES E01**  
TRUNNION MOUNTED BALL VALVE

High performance full and reduced bore trunnion mounted ball valves for process applications including refining, petrochemical, chemical, pulp and paper and other process applications



**FEATURES**

- Design optimized for higher cycle downstream process applications
- Adjustable stem packing gland eliminates need to disassemble valve or operator for fugitive emissions maintenance (specified by API 608)
- Anti-Static device optional
- ISO 5211 topworks for easy actuation
- Double Block and Bleed with self-relieving center cavity and bidirectional seating
- ASME B16.34 compliant design
- PED compliant
- ASME B16.10 long pattern Face to face, ASME B16.5 Flanges
- Fire Tested API 607 / ISO 10497 available with secondary metal seating
- Fugitive Emission ISO 15848-1 Class BH C03 certified stem packing as standard
- Blow out proof stem with position indicator
- Metal backed RPTFE bearing applied in soft seated for lower operating torque
- Tested to API 598 bubble tight seat (zero leakage) using standard RPTFE seat
- Metal Seated leakage FCI 70-2 Class V as standard, tighter shutoff available upon request
- PEEK and Metaltite® metal seated available for abrasive or higher temperature application
- Extended Bonnets available for cold insulation, cryogenic or high temperature applications
- NACE MR0175 / ISO 15156 compliant materials available
- SIL 3 Capable

**GENERAL APPLICATION**

API 608 / ISO 17292 applications cover industrial process demanding higher temperatures, pressures, and cycle rates or requiring higher performance, materials and engineered solutions, including: refining, chemical, petrochemical, and pulp and paper.

**TECHNICAL DATA**

Size range: Full Bore DN 40 to DN 600 (NPS 1½ to NPS 24)  
Reduced Bore DN 80 to DN 500 (NPS 3 to NPS 20)

Pressure rating: ASME Class 150, 300, 600, 900 and 1500

Face to face: ASME B16.10 Long Pattern  
Flange: ASME B16.5 Raised Face Standard, RTJ Available

Temperature: -29 °C to 150 °C (-20 °F to 303 °F) Standard, Optional configurations -196 °C to 500 °C (-320 °F to 932 °F)

# KTM SERIES E01

## KEY FEATURES

---

### LOWER TORQUE WITH TRUNNION MOUNTED BALL

---

With conventional floating ball designs, the upstream pressure forces the closed ball to move onto the downstream seat. The resulting torque is a function of pressure induced load force and friction between the ball and seat surfaces. The break to open torque increases proportionately with shutoff pressure differential and/or larger valve seating area. As the size or the differential pressure increases it becomes difficult to operate the valve due to the torque generated by pressure. Trunnion design ball valves alleviate this problem by ensuring that the ball and stem axes are fixed within the valve body, and the seats are energized to the ball. The differential pressure loading is distributed to the trunnion and bearings, resulting in smaller seating surface designs and greatly reduced break to open and operating torque.

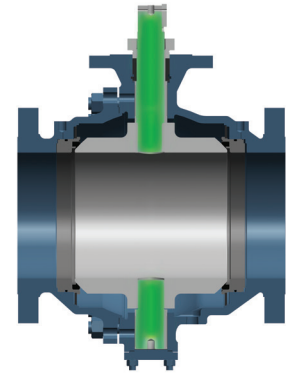

### ADJUST PACKING FOR PROCESS APPLICATIONS

---

Valves used in downstream process applications such as refining, petrochemical, and chemical typically cycle more frequently than pipeline valves used in upstream and midstream oil and gas pipelines. API 608 / ISO 17292 states “adjustable packing glands shall be accessible for re-sealing stem packing without the disassembly of the valve or operator parts,” a design feature not required for API 6D pipeline valves where the stem sealing is typically nonadjustable o-ring seals. KTM Series E01 energized gland packing is conveniently accessible, easily adjustable, and can be tightened to compensate for wear or due to temperature fluctuations and process variations. The packing also adheres to Fugitive Emission compliance programs such as LDAR (Leak Detection and Repair), with certified designs to ISO 15848-1 Class BH C03 and API 641.

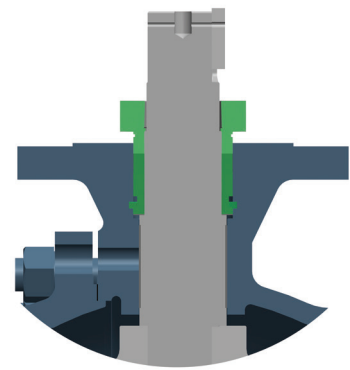

### MAINTAIN CENTER CAVITY PRESSURE WITH SELF RELIEVING SEATS

---

Should the pressure of the media inside the valve center cavity exceed the line pressure due to thermal expansion of liquids trapped, self relieving seats provide automatic pressure relief without the need of a safety or vent valve. The cavity will relieve through the downstream seat assembly because the ball is held in place by trunnion stems and the downstream seat is under less pressure than the upstream seat, thus cavity relief can occur.

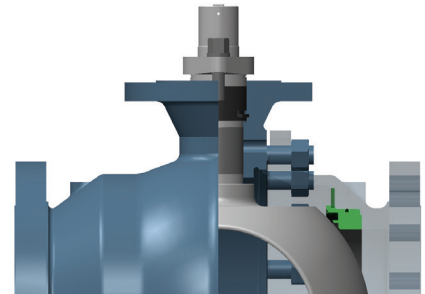

### SHUTOFF TIGHTLY WITH ENERGIZED SEATS

---

The valve achieves shut off when the seat insert presses against the closed, stationary ball due to the line pressure and seat spring acting on the upstream seat retainer. An Inconel X-750 spring provides an initial load to ensure tight shutoff even at low-pressure drops. RPTFE is the standard seat insert, with other soft seat materials such as PEEK and KTM’s E-Seat® (RPTFE/ PFA Copolymer) are available for special applications. The typical seat retainer to body seal is FKM O-ring with other options including NBR, Aflas®, or PTFE U-ring to meet extended operating temperature or fluid compatibility requirements.

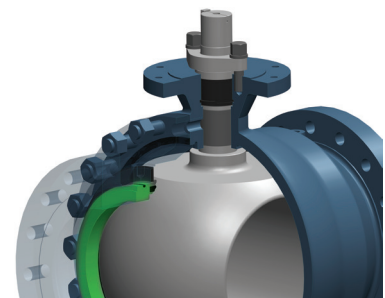

# KTM SERIES E01

## OPTIONS

### METALTITE® METAL SEATED OPTIONS

The KTM Metalltite® metal seat is available for more demanding applications such as high temperature, abrasive, slurries, etc. The standard Metalltite® Seat is stellite overlay on a 316 SS seat retainer against a 316 SS ball with hard (HRC 56-60) nickel alloy overlay. Seat options include high temperature and scraper seats, depicted below. Combinations of hard ball coating/overlays, hard seat overlays and seal options cover a wide range of applications as shown below. See KTM Metalltite® literature for additional information.

### TRUNNION METAL TRIMS

Code	Hard-Facing	Standard Packing/Gasket/Seat Retainer Seal	Max. Temperature	Application
AY	Ball: Hard chrome plated Seat: Stellite	PTFE/PTFE/FKM O-Ring	Up to 150 °C (300 °F)	Moderately non-clean media such as slurries, pulp stock, and fluids containing solids. High cycle on-off, batching and switching processes.
AG	Ball: Hard chrome plated Seat: Stellite	Graphite/Graphite/PTFE U-ring	Up to 250 °C (482 °F)	Moderately non-clean media such as slurries, pulp stock, and fluids containing solids. High cycle on-off, batching and switching processes with fire safe design.
BY	Ball: Nickel alloy overlay Seat: Stellite with scraper	PTFE/PTFE/FKM O-Ring	Up to 150 °C (300 °F)	More severe and abrasive media such as slurries, pulp stock, fluids containing solids. High cycle on-off, batching and switching processes.
BG	Ball: Nickel alloy overlay Seat: Stellite with scraper	Graphite/Graphite/PTFE U-ring	Up to 250 °C (482 °F)	More severe and abrasive media such as slurries, pulp stock, fluids containing solids. High cycle on-off, batching and switching processes with fire safe design.
BX	Ball: Nickel alloy overlay Seat: Stellite with scraper	Graphite/Graphite/Graphite	Up to 500 °C (932 °F)	Most severe, highest temperature media such as steam, hot gases and thermal fluids. Higher-frequency and higher-pressure on-off, batching and switching processes with fire safe design. Fluids containing solids and solid / powder handling.

#### METALTITE® AY/AG TRIMS WITH LINE CONTACT SEATING

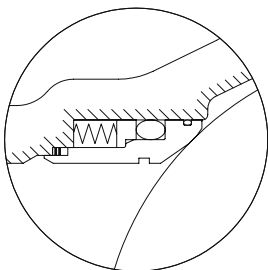

Typical metal seats have a line contact between ball and seat.

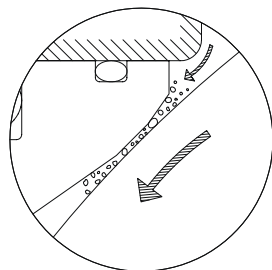

Abrasive applications or applications where buildup of media can occur reduces sealing performance.

#### METALTITE® BY/BG/BX TRIMS WITH SCRAPER SEATS

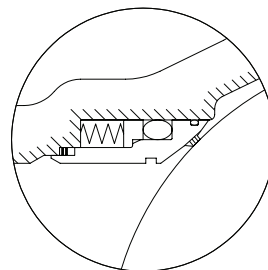

KTM Scraper seats are designed to prevent build up of material on the surface the ball.

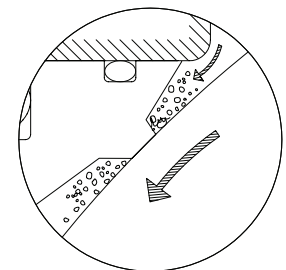

Minimize residual material by mechanically scraping the seats, ensuring maximum sealability.

### BONNET EXTENSION FOR CRYOGENIC, LOW OR HIGH TEMPERATURE

Extension bonnets are available which isolate both the stem packing and valve operator/actuator from the process in cryogenic, low or high temperature applications. This allows the stem packing and gear or powered actuator to operate at less extreme temperatures, prolonging the life of both. At cold and cryogenic temperatures, the extension isolates the packing and stem from the 'ice ball' that can form around the valve ensuring optimal performance. E1 extended bonnets are 125, 150, 175, 200, or 300 mm (5, 6, 7, 8, or 12 inches), E2 extended bonnets are 250, 300, 350, or 400 (10, 12, 14, or 16 inches) depending on valve size and pressure class. See KTM Cryogenic literature for additional information.

# KTM SERIES E01

## STANDARD MATERIALS OF CONSTRUCTION

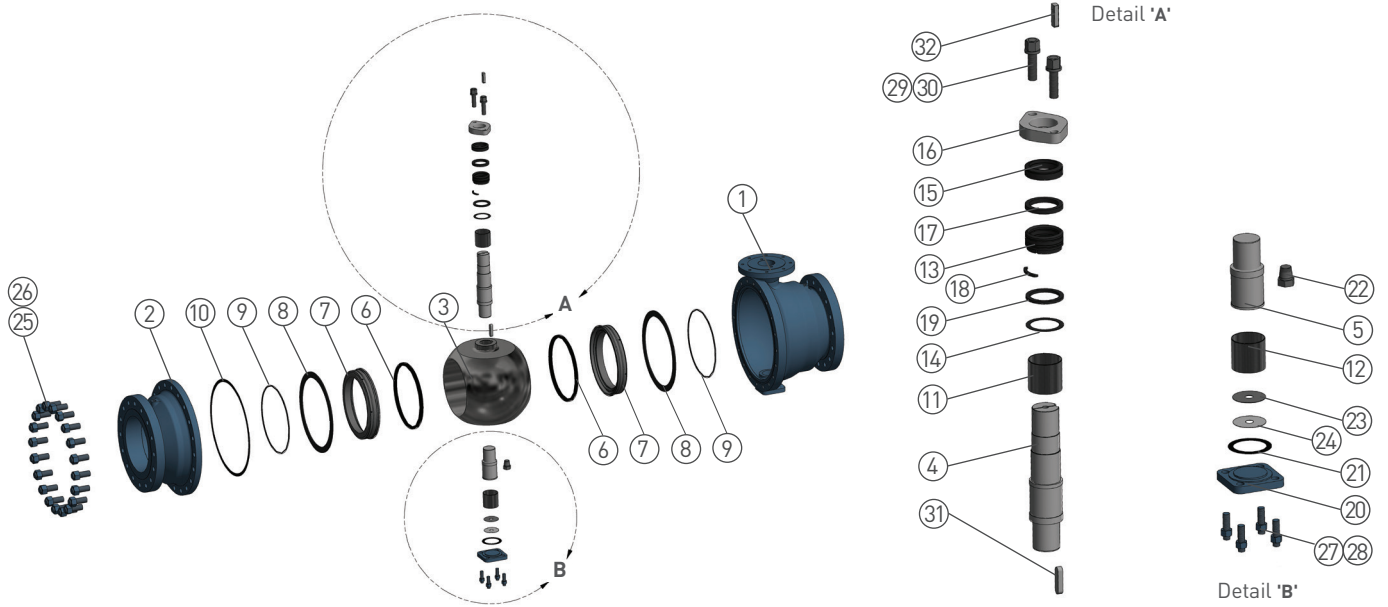
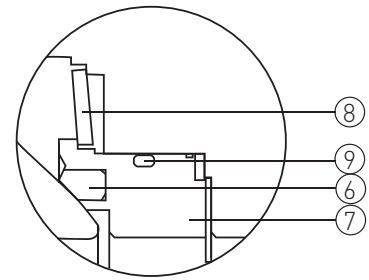

TABLE 1 - PARTS LIST

No	Part Name	Standard Material		Qty
		Carbon Steel Body	Stainless Steel Body	
1	Body	A216(G)WCB	A351(G)CF8 or A351(G)CF8M	1
2	Body cap	A216(G)WCB	A351(G)CF8 or A351(G)CF8M	1
3	Ball	A105 HCR-Plating or A351(G)CF8 or A351(G)CF8M	A351(G)CF8 or A351(G)CF8M	1
4	Stem	A276(TP)410 or A276(TP)304 or A276(TP)316	A276(TP)304 or A276(TP)316	1
5	Lower stem	A276(TP)410 or A276(TP)304 or A276(TP)316	A276(TP)304 or A276(TP)316	1
6*	Seat	Reinforced PTFE (H)	Reinforced PTFE (H)	2
7*	Seat retainer	A105 Zn-Plating or 304SS or 316SS	304SS or 316SS	2
8	Spring	Inconel X-750	Inconel X-750	2
9*	O-ring	FKM	FKM	2
10*	Gasket	Reinforced PTFE (Y) or graphite or SWG	Reinforced PTFE (Y) or graphite or SWG	1
11*	Stem bearing	Metal Backed PTFE	Metal Backed PTFE	1
12*	Stem bearing	Metal Backed PTFE	Metal Backed PTFE	1
13*	Packing	PTFE or Graphite	PTFE or Graphite	1 set
14*	Thrust bearing	Reinforced PTFE	Reinforced PTFE	1
15	Gland	304SS	304SS	1
16	Gland flange	A105 Zn-Plating or A351(G)CF8	A105 Zn-Plating or A351(G)CF8	1
17	Packing adapter	316SS	316SS	1
18	Set ring	316SS	316SS	1 set
19	Thrust washer	316SS	316SS	1
20	Lower cover	A105	304SS or 316SS	1
21*	Gasket	Reinforced PTFE (Y) or graphite or SWG	Reinforced PTFE (Y) or graphite or SWG	1
22	Drain plug	A105 Zn-Plating	316LSS	1
23*	Thrust bearing	Reinforced PTFE	Reinforced PTFE	1
24	Shim	316SS	316SS	1
25	Stud	A193(G)B7	A193(G)B7 Zn-Plating	4-64
26	Nut	A194(G)2H	A194(G)2H Zn-Plating	4-64
27	Stud	A193(G)B7	A193(G)B7 Zn-Plating	4-12
28	Nut	A194(G)2H	A194(G)2H Zn-Plating	4-12
29	Stud	A193(G)B7 Zn-Plating	A193(G)B8	2
30	Nut	A194(G)2H Zn-Plating	A194(G)8	2
31	Key	329SS	329SS	1
32	Key	Carbon steel	Carbon steel	1

### SOFT SEAT



### STEM AND PACKING

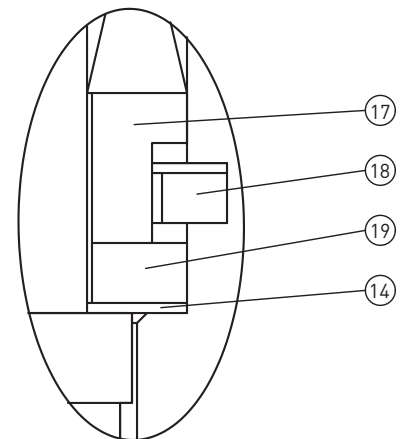

\* Included in standard repair kit

# KTM SERIES E01

## DIMENSIONS

### FULL BORE

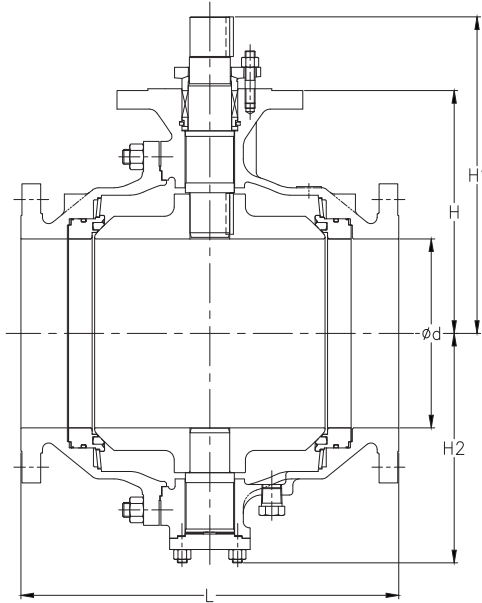

**NOTE**  
Consult factory for dimensions not shown.

**TABLE 2 - FULL BORE ASME CLASS 150, 300, 600**

Valve Size DN (NPS)	Valve Dimensions mm (inch)						Weight (Bare Stem) kg (lbs)	Flow Coefficients	
	ød	L - RF	L - RTJ	H	H1	H2		C <sub>v</sub>	K <sub>v</sub>
<b>ASME Class 150</b>									
50 (2)	51 (2.01)	178 (7.01)	-	97 (3.82)	131 (5.16)	98.5 (3.88)	14 (30.9)	480	414
80 (3)	76 (2.99)	203 (7.99)	-	119 (4.69)	170 (6.69)	131 (5.16)	25 (55.1)	1300	1121
100 (4)	102 (4.02)	229 (9.02)	-	149 (5.87)	200 (7.87)	152 (5.98)	41 (90.4)	2300	1983
150 (6)	152 (5.98)	394 (15.51)	-	193 (7.60)	278 (10.94)	207 (8.15)	98 (216.1)	5400	4655
200 (8)	203 (7.99)	457 (17.99)	-	271 (10.67)	378 (14.88)	262 (10.31)	182 (401.2)	10000	8620
250 (10)	254 (10.00)	533 (20.98)	-	338 (13.31)	431 (16.97)	330 (12.99)	344 (758.4)	16000	13792
300 (12)	305 (12.01)	610 (24.02)	-	392 (15.43)	509 (20.04)	370 (14.57)	464 (1022.9)	24000	20688
350 (14)	337 (13.27)	686 (27.01)	-	450 (17.72)	567 (22.32)	428 (16.85)	662 (1459.5)	31400	27067
400 (16)	387 (15.24)	762 (30.00)	-	484 (19.06)	646 (25.43)	453 (17.83)	957 (2109.8)	43000	37066
450 (18)	438 (17.24)	864 (34.02)	-	535 (21.06)	681 (26.81)	519 (20.43)	1342 (2958.6)	57000	49134
500 (20)	489 (19.25)	914 (35.98)	-	605 (23.82)	751 (29.57)	589 (23.19)	1792 (3950.7)	73000	62926
600 (24)	591 (23.27)	1067 (42.01)	-	740 (29.13)	944 (37.17)	710 (27.95)	3280 (7231.2)	110000	94820
<b>ASME Class 300</b>									
50 (2)	51 (2.01)	216 (8.50)	-	97 (3.82)	131 (5.16)	98.5 (3.88)	16 (35.3)	480	414
80 (3)	76 (2.99)	283 (11.14)	-	119 (4.69)	170 (6.69)	131 (5.16)	37 (81.6)	1300	1121
100 (4)	102 (4.02)	305 (12.01)	-	149 (5.87)	200 (7.87)	152 (5.98)	53 (116.8)	2300	1983
150 (6)	152 (5.98)	403 (15.87)	-	193 (7.60)	278 (10.94)	207 (8.15)	125 (275.6)	5400	4655
200 (8)	203 (7.99)	502 (19.76)	-	271 (10.67)	378 (14.88)	262 (10.31)	239 (526.9)	10000	8620
250 (10)	254 (10.00)	568 (22.36)	-	338 (13.31)	431 (16.97)	330 (12.99)	351 (773.8)	16000	13792
300 (12)	305 (12.01)	648 (25.51)	-	392 (15.43)	509 (20.04)	370 (14.57)	592 (1305.1)	24000	20688
350 (14)	337 (13.27)	762 (30.00)	-	450 (17.72)	567 (22.32)	428 (16.85)	795 (1752.1)	31400	27067
400 (16)	387 (15.24)	838 (32.99)	-	484 (19.06)	646 (25.43)	453 (17.83)	1185 (2612.5)	43000	37066
450 (18)	438 (17.24)	914 (35.98)	-	535 (21.06)	681 (26.81)	519 (20.43)	1792 (3950.7)	57000	49134
500 (20)	489 (19.25)	991 (39.02)	-	605 (23.82)	751 (29.57)	589 (23.19)	2027 (4468.8)	73000	62926
600 (24)	591 (23.27)	1143 (45.00)	-	740 (29.13)	944 (37.17)	710 (27.95)	3876 (8545.1)	110000	94820
<b>ASME Class 600</b>									
50 (2)	51 (2.01)	292 (11.50)	295 (11.61)	128 (5.04)	182 (7.17)	132 (5.20)	36 (79.4)	480	414
80 (3)	76 (2.99)	356 (14.02)	359 (14.13)	148 (5.83)	203 (7.99)	150 (5.91)	56 (123.5)	1300	1121
100 (4)	102 (4.02)	432 (17.01)	435 (17.13)	190 (7.48)	275 (10.83)	173 (6.81)	100 (220.5)	2300	1983
150 (6)	152 (5.98)	559 (22.01)	562 (22.13)	261 (10.28)	380 (14.96)	242 (9.53)	252 (555.6)	5400	4655
200 (8)	203 (7.99)	660 (25.98)	664 (26.14)	302 (11.89)	436 (17.17)	312 (12.28)	421 (928.1)	10000	8620
250 (10)	254 (10.00)	787 (30.98)	790 (31.10)	400 (15.75)	556 (21.89)	377 (14.84)	740 (1631.4)	16000	13792
300 (12)	305 (12.01)	838 (32.99)	841 (33.11)	442 (17.40)	603 (23.74)	440 (17.32)	1023 (2255.3)	24000	20688
350 (14)	337 (13.27)	889 (35.00)	892 (35.12)	485 (19.09)	645 (25.39)	490 (19.29)	1242 (2738.1)	31400	27067
400 (16)	387 (15.24)	991 (39.02)	994 (39.13)	529 (20.83)	702 (27.64)	519 (20.43)	1735 (3825.0)	43000	37066
450 (18)	438 (17.24)	1092 (42.99)	1095 (43.11)	617 (24.29)	860 (33.86)	588 (23.15)	2350 (5180.9)	57000	49134
500 (20)	489 (19.25)	1194 (47.01)	1200 (47.24)	657 (25.87)	900 (35.43)	648 (25.51)	3135 (6911.5)	73000	62926

# KTM SERIES E01

## DIMENSIONS

### REDUCED BORE

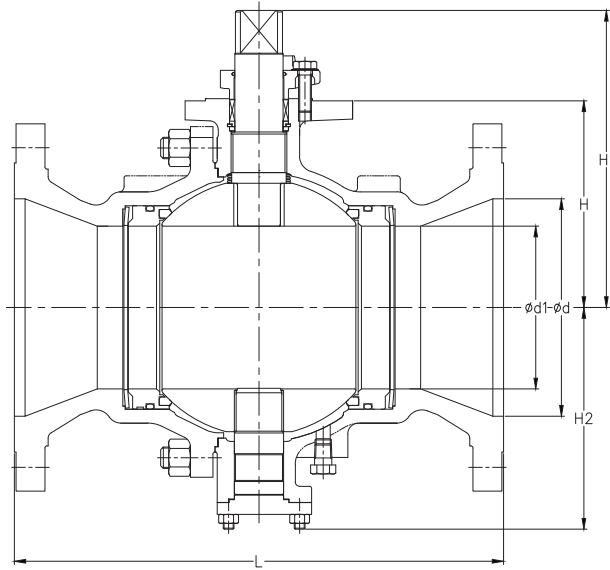

**TABLE 3 - REDUCED BORE ASME CLASS 150, 300, 600**

Valve Size DN (NPS)	Valve Dimensions mm (inch)						Weight (Bare Stem) kg (lbs)	Flow Coefficients		
	Ød	Ød1	L - RF	L - RTJ	H	H1		H2	C <sub>v</sub>	K <sub>v</sub>
<b>ASME Class 150</b>										
80 (3)	76 (2.99)	51 (2.01)	203 (7.99)	-	97 (3.82)	131 (5.16)	98.5 (3.88)	20 (44.1)	200	172
100 (4)	102 (4.02)	76 (2.99)	229 (9.02)	-	119 (4.69)	170 (6.69)	131 (5.16)	32 (70.5)	770	664
150 (6)	152 (5.98)	102 (4.02)	394 (15.51)	-	149 (5.87)	200 (7.87)	152 (5.98)	58 (126.8)	1800	1552
200 (8)	203 (7.99)	152 (5.98)	457 (17.99)	-	193 (7.60)	278 (10.94)	207 (8.15)	120 (264.6)	2500	2155
250 (10)	254 (10.00)	203 (7.99)	533 (20.98)	-	271 (10.67)	378 (14.88)	262 (10.31)	210 (463.0)	4500	3879
300 (12)	305 (12.01)	254 (10.00)	610 (24.02)	-	327 (12.87)	421 (16.57)	334 (13.15)	374 (824.5)	8000	6896
350 (14)	337 (13.27)	305 (12.01)	688 (27.09)	-	387 (15.24)	504 (19.84)	384 (15.12)	500 (1102.3)	12000	10344
400 (16)	387 (15.24)	337 (13.27)	762 (30.00)	-	450 (17.72)	567 (22.32)	428 (16.85)	743 (1638.0)	14000	12068
<b>ASME Class 300</b>										
80 (3)	76 (2.99)	51 (2.01)	283 (11.14)	-	97 (3.82)	131 (5.16)	98.5 (3.88)	28 (61.7)	200	172
100 (4)	102 (4.02)	76 (2.99)	305 (12.01)	-	119 (4.69)	170 (6.69)	131 (5.16)	48 (105.8)	770	664
150 (6)	152 (5.98)	102 (4.02)	403 (15.87)	-	149 (5.87)	200 (7.87)	152 (5.98)	80 (176.4)	1800	1552
200 (8)	203 (7.99)	152 (5.98)	419 (16.50)	-	193 (7.60)	278 (10.94)	207 (8.15)	151 (332.9)	2500	2155
250 (10)	254 (10.00)	203 (7.99)	457 (17.99)	-	271 (10.67)	378 (14.88)	262 (10.31)	270 (595.2)	4500	3879
300 (12)	305 (12.01)	254 (10.00)	648 (25.51)	-	327 (12.87)	421 (16.57)	334 (13.15)	523 (1153.0)	8000	6896
350 (14)	337 (13.27)	305 (12.01)	762 (30.00)	-	387 (15.24)	504 (19.84)	384 (15.12)	688 (1516.8)	12000	10344
400 (16)	387 (15.24)	337 (13.27)	838 (32.99)	-	450 (17.72)	567 (22.32)	428 (16.85)	948 (2090.0)	14000	12068
<b>ASME Class 600</b>										
150 (6)	152 (5.98)	102 (4.02)	559 (22.01)	562 (22.13)	190 (7.48)	275 (10.83)	173 (6.81)	141 (310.9)	1800	1552
200 (8)	203 (7.99)	152 (5.98)	660 (25.98)	664 (26.14)	261 (10.28)	380 (14.96)	242 (9.53)	308 (679.0)	2500	2155
250 (10)	254 (10.00)	203 (7.99)	787 (30.98)	790 (31.10)	302 (11.89)	436 (17.17)	312 (12.28)	528 (1164.0)	4500	3879
300 (12)	305 (12.01)	254 (10.00)	838 (32.99)	841 (33.11)	400 (15.75)	556 (21.89)	377 (14.84)	784 (1728.4)	8000	6896

**NOTES**

Consult factory for dimensions not shown.

Face-to-face dimensions for E01 Class 300 reduced bore valves with size

DN 200 - 250 (NPS 8 - 10) are complied with ASME B16.10 short pattern.

# KTM SERIES E01

## DIMENSIONS

### FULL BORE

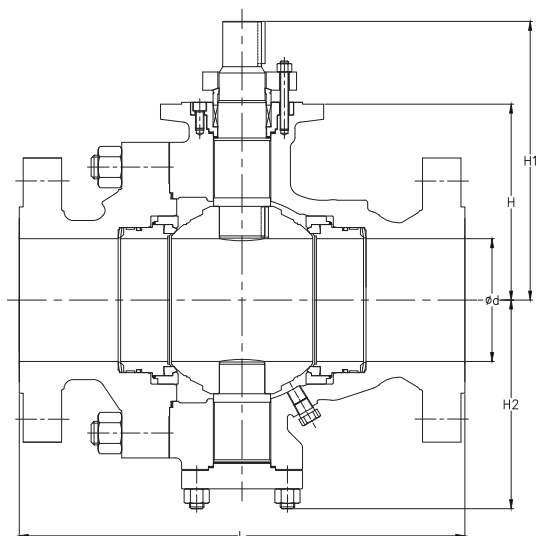

### REDUCED BORE

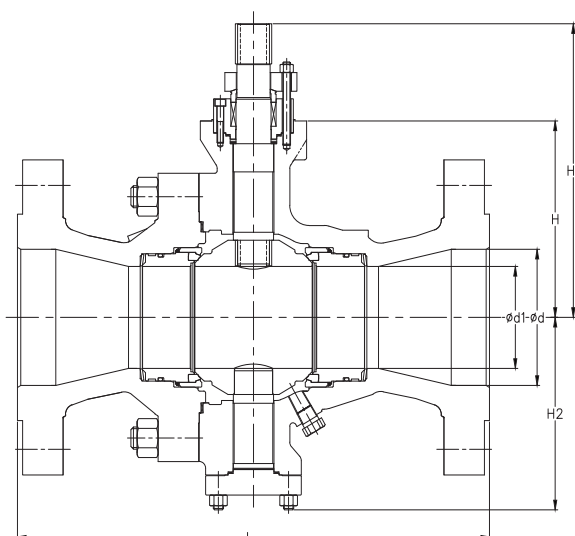

**TABLE 4 - FULL BORE ASME CLASS 900, 1500**

Valve Size DN (NPS)	Valve Dimensions mm (inch)						Weight (Bare Stem) kg (lbs)	Flow Coefficients	
	Ød	L - RF	L - RTJ	H	H1	H2		C <sub>v</sub>	K <sub>v</sub>
<b>ASME Class 900</b>									
40 (1½)	38 (1.50)	305 (12.01)	305 (12.01)	143 (5.63)	210 (8.27)	144 (5.67)	42 (92.7)	260	224
50 (2)	51 (2.01)	368 (14.49)	371 (14.61)	145.5 (5.73)	219.5 (8.64)	149 (5.87)	66 (145.6)	480	414
80 (3)	76 (2.99)	381 (15.00)	384 (15.12)	194.0 (7.64)	312.0 (12.28)	204 (8.03)	121 (266.9)	1300	1121
100 (4)	102 (4.02)	457 (17.99)	460 (18.11)	233.0 (9.17)	342.5 (13.48)	225 (8.89)	171 (377.1)	2300	1983
150 (6)	152 (5.98)	610 (24.02)	613 (24.13)	293.0 (11.54)	438.0 (17.24)	291 (11.46)	323 (712.3)	5400	4655
200 (8)	201 (7.91)	737 (29.02)	740 (29.13)	324.0 (12.76)	461.0 (18.15)	344 (13.54)	595 (1312.0)	10000	8620
250 (10)	252 (9.92)	838 (32.99)	841 (33.11)	451.0 (17.76)	612.0 (24.09)	439 (17.28)	1048 (2310.9)	16000	13792
300 (12)	303 (11.93)	965 (37.99)	968 (38.11)	495.0 (19.49)	675.0 (26.57)	495 (19.49)	1430 (3153.2)	24000	20688
350 (14)	322 (12.68)	1029 (40.51)	1038 (40.87)	525.0 (20.67)	732.0 (28.82)	527 (20.75)	1815 (4002.1)	31400	27067
400 (16)	373 (14.69)	1130 (44.49)	1140 (44.88)	609.0 (23.98)	846.0 (33.31)	617 (24.29)	2357 (5197.2)	43000	37066
450 (18)	423 (16.65)	1219 (47.99)	1232 (48.50)	720.0 (28.35)	873.0 (34.37)	705 (27.76)	3330 (7342.7)	57000	49134
500 (20)	471 (18.54)	1321 (52.01)	1334 (52.52)	748.0 (29.45)	901.0 (35.47)	718 (28.27)	4230 (9327.2)	73000	62926
<b>ASME Class 1500</b>									
40 (1½)	38 (1.50)	305 (12.01)	305 (12.01)	143 (5.63)	210 (8.27)	144 (5.67)	42 (92.7)	260	224
50 (2)	51 (2.01)	368 (14.49)	371 (14.61)	145.5 (5.73)	219.5 (8.64)	149 (5.87)	66 (145.6)	480	414
80 (3)	76 (2.99)	469 (18.46)	472 (18.58)	211.0 (8.31)	331.0 (13.03)	246 (9.69)	184 (405.8)	1300	1121
100 (4)	102 (4.02)	546 (21.50)	549 (21.61)	230.0 (9.06)	362.0 (14.25)	259 (10.20)	235 (518.2)	2300	1983
150 (6)	146 (5.75)	705 (27.76)	711 (27.99)	372.0 (14.65)	509.0 (20.04)	390 (15.35)	549 (1210.6)	5400	4655
200 (8)	194 (7.64)	832 (32.76)	841 (33.11)	410.0 (16.14)	581.0 (22.87)	390 (15.35)	834 (1839.0)	10000	8620
250 (10)	241 (9.49)	991 (39.02)	1000 (39.37)	504.0 (19.84)	616.0 (24.25)	500 (19.69)	1582 (3488.4)	16000	13792
300 (12)	289 (11.38)	1130 (44.49)	1146 (45.12)	565.0 (22.24)	699.0 (27.52)	546 (21.50)	2407 (5307.5)	24000	20688
350 (14)	318 (12.52)	1257 (49.49)	1276 (50.24)	630.0 (24.80)	753.0 (29.65)	586 (23.07)	3207 (7071.5)	31400	27067
400 (16)	362 (14.25)	1384 (54.49)	1407 (55.39)	685.0 (26.97)	844.0 (33.23)	670 (26.38)	4330 (9547.7)	43000	37066

**TABLE 5 - REDUCED BORE ASME CLASS 900**

Valve Size DN (NPS)	Valve Dimensions mm (inch)						Weight (Bare Stem) kg (lbs)	Flow Coefficients		
	Ød	Ød1	L - RF	L - RTJ	H	H1		H2	C <sub>v</sub>	K <sub>v</sub>
<b>ASME Class 900</b>										
80 (3)	76 (2.99)	51 (2.01)	381 (15.00)	384 (15.12)	145.5 (5.73)	219.5 (8.64)	149 (5.87)	143 (315.4)	200	172
100 (4)	102 (4.02)	76 (2.99)	457 (17.99)	460 (18.11)	194.0 (7.64)	312.0 (12.28)	204 (8.03)	175 (385.9)	770	664
150 (6)	152 (5.98)	102 (4.02)	610 (24.02)	613 (24.13)	233.0 (9.17)	342.5 (13.48)	225 (8.86)	232 (511.6)	1800	1552
200 (8)	201 (7.91)	152 (5.98)	737 (29.02)	740 (29.13)	293.0 (11.54)	438.0 (17.24)	291 (11.46)	440 (970.2)	2500	2155

**NOTE**

Consult factory for dimensions not shown.

# KTM SERIES E01

## PRESSURE AND TEMPERATURE CURVES

### PRESSURE - TEMPERATURE CURVES

#### CLASS 150, 300 AND 600

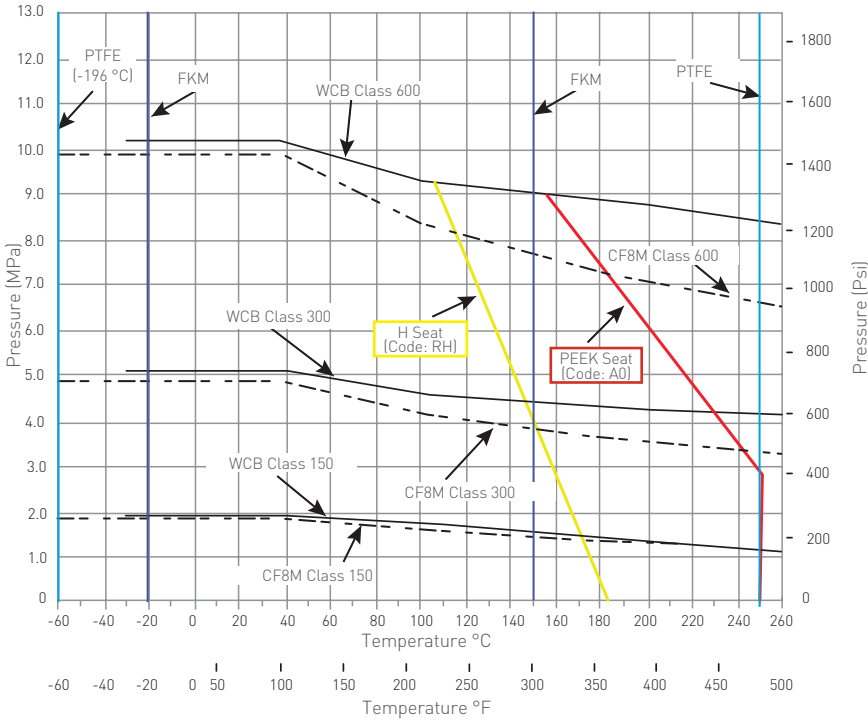

**TABLE 6 - Packing, gasket and seal material temperature considerations**

Material	Min. Temp.	Max. Temp.
FKM (Viton O-ring)	-20 °C (-4 °F)	150 °C (302 °F)
PTFE U-ring	-196 °C (-320 °F)	250 °C (482 °F)
NBR O-ring	-30 °C (-22 °F)	80 °C (176 °F)
FEPM (Aflas®)	N/A	200 °C (392 °F)
FFKM (Kalrez®)	N/A	260 °C (500 °F)
Low temp. NBR	-46 °C (-51 °F)	80 °C (176 °F)
FVMQ (Fluorosilicone)	-45 °C (-49 °F)	120 °C (248 °F)

#### CLASS 900 AND 1500

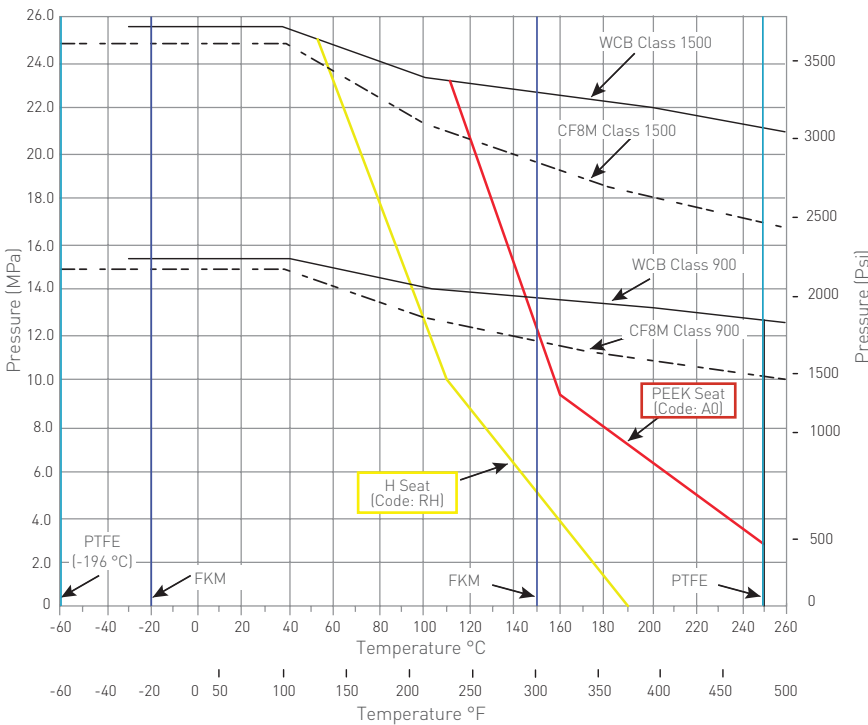

#### NOTES

- For trunnion valve high temperature and metal seated pressure / temperature curves, see the Metallite® Technical Data Sheet.
- For trunnion valve low temperature and cryogenic pressure / temperature curves, see the Cryogenic Technical Data Sheet.

AFLAS® is a registered trademark of Asahi Glass Co. Ltd.

Kalrez® is a registered trademark of E.I du Pont de Nemours and Company.



# KTM SERIES E01

## BODY STYLES

### BODY STYLES

E01 Split body trunnion ball valves						
Global model code	Legacy KTM model code	Ball style	Bore	Connection	Pressure class	Sizes
E01	E0125	Trunnion type	Full bore	Raised face or smooth finish	ASME 150, JIS 10K	DN 50 - 200 (NPS 2 - 8)
E01	E0126	Trunnion type	Full bore	Raised face or smooth finish	ASME 300, JIS 20K	DN 50 - 200 (NPS 2 - 8)
E01	E0821	Trunnion type	Reduced bore	Raised face or smooth finish	ASME 150, JIS 10K	DN 80 - 250 (NPS 3 - 10)
E01	E0822	Trunnion type	Reduced bore	Raised face or smooth finish	ASME 300, JIS 20K	DN 80 - 250 (NPS 3 - 10)
E01	E0105	Trunnion type	Full bore	Raised face or smooth finish	ASME 150, JIS 10K	DN 250 - 600 (NPS 10 - 24)
E01	E0106	Trunnion type	Full bore	Raised face or smooth finish	ASME 300, JIS 20K	DN 250 - 600 (NPS 10 - 24)
E01	E0801	Trunnion type	Reduced bore	Raised face or smooth finish	ASME 150, JIS 10K	DN 300 - 500 (NPS 12 - 20)
E01	E0802	Trunnion type	Reduced bore	Raised face or smooth finish	ASME 300, JIS 20K	DN 300 - 500 (NPS 12 - 20)
E01	E0108	Trunnion type	Full bore	Raised face or ring type joint	ASME 600, JIS 40K	DN 50 - 500 (NPS 2 - 20)
E01	E0804	Trunnion type	Reduced bore	Raised face or ring type joint	ASME 600, JIS 40K	DN 150 - 300 (NPS 6 - 12)
E01	E0109	Trunnion type	Full bore	Ring type joint or raised face	ASME 900, JIS 63K	DN 40 - 500 (NPS 1½ - 20)
E01	E0807	Trunnion type	Reduced bore	Ring type joint or raised face	ASME 900, JIS 63K	DN 80 - 200 (NPS 3 - 8)
E01	E0110	Trunnion type	Full bore	Ring type joint or raised face	ASME 1500	DN 40 - 400 (NPS 1½ - 16)

VCTDS-11596-EN © 2019, 2021 Emerson Electric Co. All rights reserved 11/21. KTM is a mark owned by one of the companies in the Emerson Automation Solutions business unit of Emerson Electric Co. The Emerson logo is a trademark and service mark of Emerson Electric Co. All other marks are the property of their prospective owners.

The contents of this publication are presented for informational purposes only, and while every effort has been made to ensure their accuracy, they are not to be construed as warranties or guarantees, express or implied, regarding the products or services described herein or their use or applicability. All sales are governed by our terms and conditions, which are available upon request. We reserve the right to modify or improve the designs or specifications of such products at any time without notice.

Emerson Electric Co. does not assume responsibility for the selection, use or maintenance of any product. Responsibility for proper selection, use and maintenance of any Emerson Electric Co. product remains solely with the purchaser.

[Emerson.com/FinalControl](https://www.emerson.com/FinalControl)