

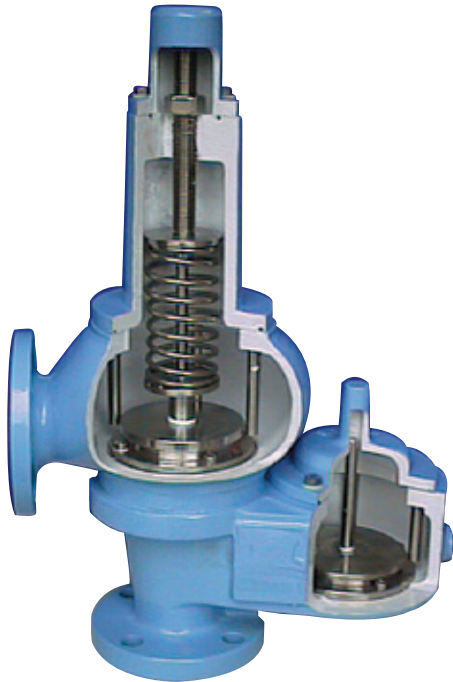

ANDERSON GREENWOOD WHESSOE SERIES 4020A PRESSURE AND VACUUM RELIEF VALVES

Weight or spring loaded valves capable of providing pressure and vacuum relief that pipe away to a closed header system



FEATURES

- Weight or spring loaded models available.
- Choice of body materials.
- Removable stainless steel seats.
- Low ambient temperature version available.
- Full flange.
- ANSI and DIN flanges.
- Self draining body.

GENERAL APPLICATION

4020A Series valves provide pressure and vacuum relief in storage tank farms, the petroleum and chemical sectors and for the protection of anaerobic waste digesters.

TECHNICAL DATA

Materials: Aluminum, carbon steel, stainless steel
Sizes: 2" to 12" (DN 50 to 300)
Pressure settings: 2.5 mbar to 3.5 bar
Vacuum settings: 2.5 mbar to 800 mbar



ANDERSON GREENWOOD WHESSOE SERIES 4020A PRESSURE AND VACUUM RELIEF VALVES

DIMENSIONS AND WEIGHTS

4020A WEIGHT LOADED PRESSURE AND VACUUM

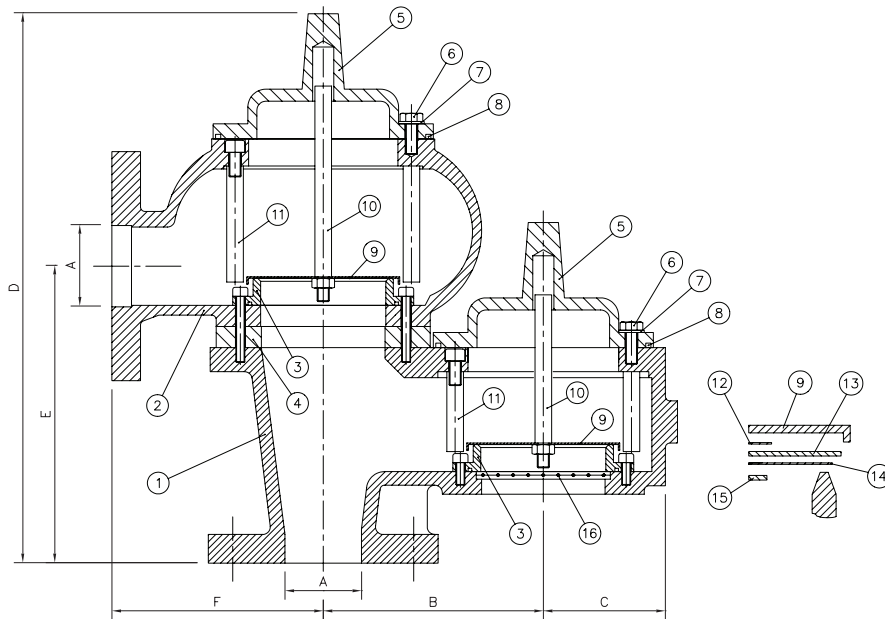

PARTS LIST

Item	Description	Alum spec.	C.steel	SS spec
1	Valve body inlet	Aluminum	WCB	316 SS
2	Valve body outlet	Aluminum	WCB	316 SS
3	Removable seat	Aluminum	316 SS	316 SS
4	Spacer ring	Aluminum	C Steel	316 SS
5	Cover	Aluminum	WCB	316 SS
6	Cover screws	ZP Steel	ZP Steel	18/8 SS
7	Sealing washers	G fiber	G fiber	G fiber
8	O ring seal	Nitrile	Nitrile	Nitrile
9	Pallet	316 SS	316 SS	316 SS
10	Pallet stem	316 SS	316 SS	316 SS
11	Pallet guide posts	316 SS	316 SS	316 SS
12	Spacer disc	Non-asbestos	Non-asbestos	Non-asbestos
13	Diaphragm back.disc	Non-asbestos	Non-asbestos	Non-asbestos
14	Diaphragm	PTFE	PTFE	PTFE
15	Diaphragm supp.disc	316 SS	316 SS	316 SS
16	Screen	Galv Steel	Galv Steel	18/8 SS

DIMENSIONS WEIGHT LOADED VALVE

Nom. size		A	B	C	D	E	F
DN	in						
50	2	50.8	146	81.0	364	197	140
80	3	76.2	185	100.0	424	238	180
100	4	101.6	213	118.5	472	261	200
150	6	152.4	280	142.5	517	308	242
200	8	203.2	335	173.0	590	362	310
250	10	254.0	397	202.0	650	400	358
300	12	304.8	450	235.0	725	435	393

WEIGHTS WEIGHT/WEIGHT LOADED VALVE

in	Aluminum	Steel/SS
2	9	41
3	12	60
4	18	85
6	32	113
8	50	168
10	76	250
12	101	346

ANDERSON GREENWOOD WHESSOE SERIES 4020A PRESSURE AND VACUUM RELIEF VALVES

DIMENSIONS AND WEIGHTS

4020A SPRING LOADED PRESSURE/WEIGHT LOADED VACUUM

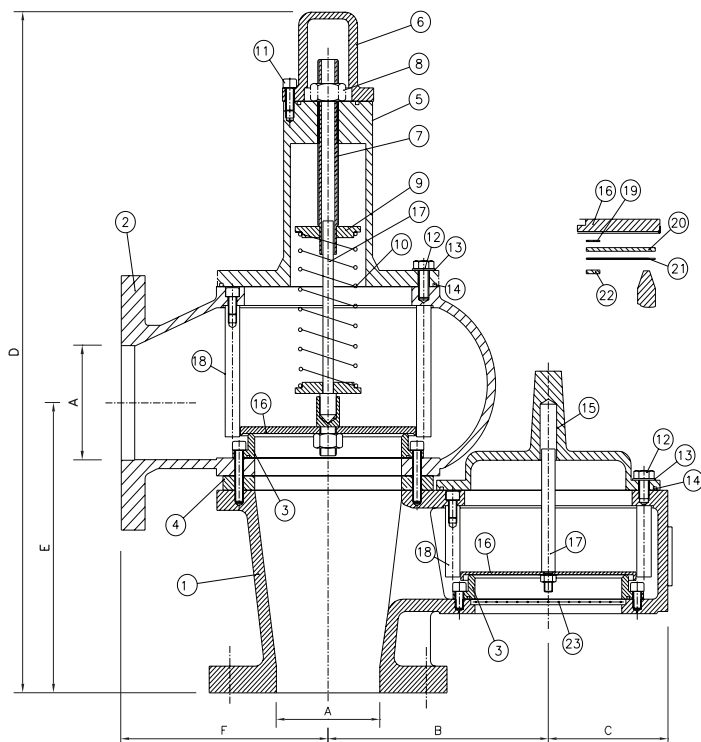

PARTS LIST

Item	Description	Alum spec.	C. steel	SS. spec	Item	Description	Alum spec.	C. steel	SS. spec
1	Valve body inlet	Aluminum	WCB	316 SS	13	Sealing washers	G fiber	G fiber	G fiber
2	Valve body outlet	Aluminum	WCB	316 SS	14	O-ring seal	Nitrile	Nitrile	Nitrile
3	Removable seat	Aluminum	316 SS	316 SS	15	Cover	Aluminum	WCB	316 SS
4	Spacer ring	Aluminum	C.Steel	316 SS	16	Pallet	316 SS	316 SS	316 SS
5	Spring bonnet	Aluminum	WCB	316 SS	17	Pallet stem	316 SS	316 SS	316 SS
6	Bonnet cap	Aluminum	WCB	316 SS	18	Pallet guide posts	316 SS	316 SS	316 SS
7	Adjustment screw	316 SS	316 SS	316 SS	19	Spacer disc	Non-asbestos	Non-asbestos	Non-asbestos
8	Locknut	18/8 SS	18/8 SS	18/8 SS	20	Diaphragm back. disc	Non-asbestos	Non-asbestos	Non-asbestos
9	Spring washers	316 SS	316 SS	316 SS	21	Diaphragm	PTFE	PTFE	PTFE
10	Spring	316 SS	316 SS	316 SS	22	Diaphragm supp. disc	316 SS	316 SS	316 SS
11	Cap screw	ZP Steel	ZP Steel	18/8 SS	23	Screen	Galv St	Galv St	18/8 SS
12	Bonnet screws	ZP Steel	ZP Steel	18/8 SS					

DIMENSIONS SPRING LOADED VALVE

Nom. size		A	B	C	D	E	F
DN	in						
50	2	50.8	146	81.0	528	197	140
80	3	76.2	185	100.0	571	238	180
100	4	101.6	213	118.5	612	261	208
150	6	152.4	280	142.5	670	310	242
200	8	203.2	335	173.0	730	362	310
250	10	254.0	397	202.0	831	400	358
300	12	304.8	450	235.0	870	435	393

WEIGHTS SPRING/WEIGHT LOADED VALVE

in	Aluminum	Steel/SS
2	11	48
3	16	70
4	25	97
6	40	125
8	60	188
10	88	280
12	115	385

ANDERSON GREENWOOD WHESSOE SERIES 4020A PRESSURE AND VACUUM RELIEF VALVES

DIMENSIONS AND WEIGHTS

4020A SPRING LOADED PRESSURE AND VACUUM

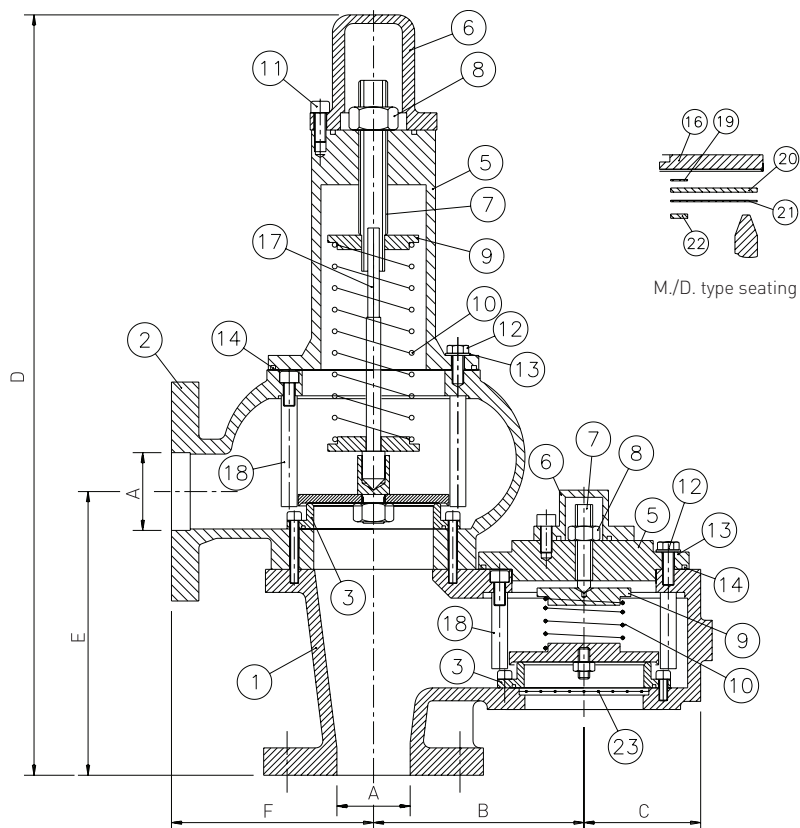

PARTS LIST

Item	Description	Alum spec.	C.steel	SS spec
1	Valve body inlet	Aluminum	WCB	316 SS
2	Valve body outlet	Aluminum	WCB	316 SS
3	Removable seat	Aluminum	316 SS	316 SS
5	Spring bonnet	Aluminum	WCB	316 SS
6	Bonnet cap	Aluminum	WCB	316 SS
7	Adjustment screw	316 SS	316 SS	316 SS
8	Locknut	18/8 SS	18/8 SS	18/8 SS
9	Spring washers	316 SS	316 SS	316 SS
10	Spring	316 SS	316 SS	316 SS
11	Cap screw	ZP Steel	ZP Steel	18/8 SS
12	Bonnet screws	ZP Steel	ZP Steel	18/8 SS
13	Sealing washers	G fiber	G fiber	G fiber
14	O ring seal	Nitrile	Nitrile	Nitrile
16	Pallet	316 SS	316 SS	316 SS
17	Pallet stem	316 SS	316 SS	316 SS
18	Pallet guide posts	316 SS	316 SS	316 SS
19	Spacer disc	Non-asbestos	Non-asbestos	Non-asbestos
20	Diaphragm back.disc	Non-asbestos	Non-asbestos	Non-asbestos
21	Diaphragm	PTFE	PTFE	PTFE
22	Diaphragm supp.disc	316 SS	316 SS	316 SS
23	Screen	Galv St	Galv St	18/8 SS

WEIGHTS SPRING/SPRING LOADED VALVES (kg)

	2"	3"	4"	6"	8"	10"	12"
*	13	20	32	48	70	100	130
**	55	80	109	137	208	310	424

* Aluminum

** CS/SS

ANDERSON GREENWOOD WHESSOE SERIES 4020A PRESSURE AND VACUUM RELIEF VALVES

4020A WEIGHT LOADED PRESSURE/SPRING LOADED VACUUM

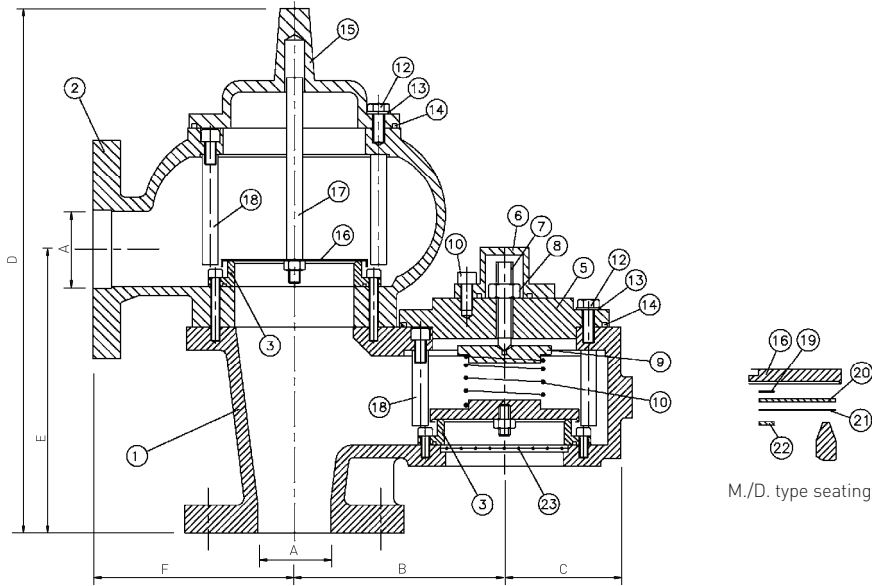

PARTS LIST

Item	Description	Alum spec.	C. steel	SS. spec
1	Valve body inlet	Aluminum	WCB	316 SS
2	Valve body outlet	Aluminum	WCB	316 SS
3	Removable seat	Aluminum	316 SS	316 SS
5	Spring bonnet	Aluminum	WCB	316 SS
6	Bonnet cap	Aluminum	WCB	316 SS
7	Adjustment screw	316 SS	316 SS	316 SS
8	Locknut	18/8 SS	18/8 SS	18/8 SS
9	Spring washers	316 SS	316 SS	316 SS
10	Spring	316 SS	316 SS	316 SS
11	Cap screws	ZP Steel	ZP Steel	18/8 SS
12	Bonnet screws	ZP Steel	ZP Steel	18/8 SS
13	Sealing washers	G fiber	G fiber	G fiber
14	O-ring seal	Nitrile	Nitrile	Nitrile
15	Cover	Aluminum	WCB	316 SS
16	Pallet	316 SS	316 SS	316 SS
17	Pallet stem	316 SS	316 SS	316 SS
18	Pallet guide posts	316 SS	316 SS	316 SS
19	Spacer disc	Non-asbestos	Non-asbestos	Non-asbestos
20	Diaphragm back. disc	Non-asbestos	Non-asbestos	Non-asbestos
21	Diaphragm	PTFE	PTFE	PTFE
22	Diaphragm supp. disc	316 SS	316 SS	316 SS
23	Screen	St. St	St. St	St. St

WEIGHTS WEIGHT/SPRING LOADED VALVES (KG)

	2"	3"	4"	6"	8"	10"	12"
*	11	16	25	40	60	88	115
**	48	70	97	125	188	280	385

* Aluminum

** CS/SS

ANDERSON GREENWOOD WHESSOE 4020A PRESSURE AND VACUUM RELIEF VALVES

Max./min. set weight loaded

Min. set pressure	2.5 mbar
Min. set vacuum	2.5 mbar
Max. set pressure	70 mbar
Max. set vacuum	60 mbar

Max./min. set spring loaded

Min. set pressure	70 mbar
Min. set vacuum	2.5 mbar
Max. set pressure	3.5 barg
Max. set vacuum	800 mbar

4020A WEIGHT LOADED PRESSURE FLOW FIGURES

Set pressure mbar	2"			3"			4"			6"			8"			10"			12"				
	Over pressure	20%	35%	50%	Over pressure	20%	35%	50%	Over pressure	20%	35%	50%	Over pressure	20%	35%	50%	Over pressure	20%	35%	50%	Over pressure	20%	35%
2.5	38	52	72	84	116	161	150	206	286	338	464	644	601	825	1146	939	1289	1790	1352	1856	2577		
10	75	103	143	169	232	322	300	412	573	676	928	1289	1202	1650	2291	1877	2578	3580	2704	3712	5155		
25	119	163	226	267	367	509	475	652	906	1069	1467	2038	1900	2608	3622	2969	4076	5660	4275	5869	8151		
50	168	231	320	378	519	720	672	922	1281	1511	2075	2882	2687	3689	5123	4198	5764	8005	6045	8300	11527		
60	184	253	351	414	568	789	736	1010	1403	1656	2273	3157	2943	4041	5612	4599	6314	8769	6622	9092	12627		

Flow in m³/hr

4020A WEIGHT LOADED VACUUM FLOW FIGURES

Set vacuum mbar	2"			3"			4"			6"			8"			10"			12"				
	Over pressure	20%	35%	50%	Over pressure	20%	35%	50%	Over pressure	20%	35%	50%	Over pressure	20%	35%	50%	Over pressure	20%	35%	50%	Over pressure	20%	35%
2.5	44	58	75	99	131	168	175	232	298	395	523	671	702	929	1194	1096	1451	1865	1579	2090	2686		
10	88	116	149	197	261	336	351	464	597	789	1045	1343	1403	1858	2387	2192	2903	3730	3157	4180	5371		
25	139	184	236	312	413	531	555	734	944	1248	1652	2123	2219	2938	3775	3466	4590	5898	4992	6610	8493		
50	196	260	334	441	584	751	784	1039	1335	1765	2337	3003	3138	4154	5338	4902	6491	8341	7059	9347	12011		
60	215	284	365	483	640	822	859	1138	1462	1933	2560	3289	3437	4551	5847	5370	7111	9137	7733	10240	13157		

Flow in m³/hr

4020A SPRING LOADED PRESSURE FLOW FIGURES

Set pressure mbar	2"			3"			4"			6"			8"			10"			12"				
	Over pressure	20%	35%	50%	Over pressure	20%	35%	50%	Over pressure	20%	35%	50%	Over pressure	20%	35%	50%	Over pressure	20%	35%	50%	Over pressure	20%	35%
150	185	255	316	417	575	712	741	1022	1266	1666	2299	2848	2963	4086	5064	4629	6385	7912	6666	9194	11393		
250	239	330	409	539	743	921	957	1321	1636	2154	2971	3682	3830	5282	6546	5984	8254	10228	8617	11885	14728		
500	339	467	579	762	1051	1302	1354	1868	2314	3047	4202	5207	5416	7470	9257	8463	11673	14464	12187	16808	20829		
750	414	571	708	932	1286	1593	1657	2286	2833	3729	5143	6373	6629	9143	11330	10358	14286	17703	14915	20572	25493		

Flow in m³/hr

4020A SPRING LOADED VACUUM FLOW FIGURES

Set vacuum mbar	2"			3"			4"			6"			8"			10"			12"				
	Over pressure	20%	35%	50%	Over pressure	20%	35%	50%	Over pressure	20%	35%	50%	Over pressure	20%	35%	50%	Over pressure	20%	35%	50%	Over pressure	20%	35%
150	184	251	301	414	565	676	736	1005	1202	1657	2261	2705	2946	4019	4809	4602	6280	7514	6627	9043	10820		
250	238	325	389	535	731	874	952	1299	1554	2142	2923	3497	3808	5196	6217	5950	8118	9714	8567	11690	13987		
500	337	459	549	757	1033	1236	1346	1837	2198	3029	4133	4945	5385	7348	8792	8414	11481	13737	12116	16532	19781		
750	412	562	673	927	1265	1513	1648	2248	2690	3707	5059	6053	6591	8993	10760	10298	14051	16813	14829	20234	24211		

Flow in m³/hr

Neither Emerson, Emerson Automation Solutions, nor any of their affiliated entities assumes responsibility for the selection, use or maintenance of any product. Responsibility for proper selection, use, and maintenance of any product remains solely with the purchaser and end user.

Anderson Greenwood is a mark owned by one of the companies in the Emerson Automation Solutions business unit of Emerson Electric Co. Emerson Automation Solutions, Emerson and the Emerson logo are trademarks and service marks of Emerson Electric Co. All other marks are the property of their respective owners.

The contents of this publication are presented for informational purposes only, and while every effort has been made to ensure their accuracy, they are not to be construed as warranties or guarantees, express or implied, regarding the products or services described herein or their use or applicability. All sales are governed by our terms and conditions, which are available upon request. We reserve the right to modify or improve the designs or specifications of such products at any time without notice.