

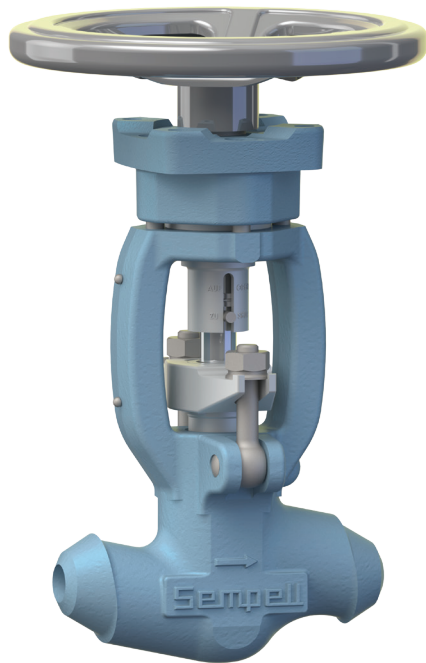

## SEMPPELL HIGH PRESSURE STOP VALVES

MODEL VA500 (ASME)

Designed for the isolation and control of high temperature and high pressure systems, this multipurpose globe valve can be used in a wide variety of applications.



### FEATURES

- T-pattern globe type
- One-piece die-forged body design
- Wear resistant stellite body seat
- Conical seat with line contact sealing
- Visual position indicator
- Non-rising hand wheel
- Prepared for later automation in service
- Low pressure loss due to optimized flow path
- Small driving forces
- Easy maintenance
- Code compliance with ASME B16.34 and PED

### GENERAL APPLICATION

These valves are designed for high pressure applications in process control industries such as power generation, hydrocarbon production, chemical processing and refining. Applications include - vents, drains, bypass systems, warm-up lines, etc. wherever reliable leak tight performance is required.

### TECHNICAL DATA

Size:	NPS 3/8 - 2 1/2
Pressure rating:	Class 1690 STD / LTD Class 2680 STD / LTD
Temperature rating:	-29°C to 625°C (-20°F to 1150°F)
Body material:	SA 105 SA 182 F12 SA 182 F22 SA 182 F91 SA 182 F347
Connection:	Butt weld ends acc. to ASME B16.25 Socket weld ends acc. to ASME B16.11

# SEMPELL HIGH PRESSURE STOP VALVES

## MODEL VA500 (ASME)

Large non-rising handwheel for easy operation.

Equipped with a mounting flange acc. to ISO 5210. No additional adaptor needed. An electric actuator can be mounted during operation easily.

Visual position indicator. Clearly indicates valve position at all times.

One-piece, non-rotating stem made of 17% Cr steel to ensure long life time of packing and easy mounting of a multiturn actuator without changing any parts.

Gland screws designed as eye bolts fixed to the valve, i.e. they cannot get lost during disassembly as they remain at the valve body.

One-piece die-forged body. The bonnet is an integral part of the body (bonnet less design) without any additional cover seal.

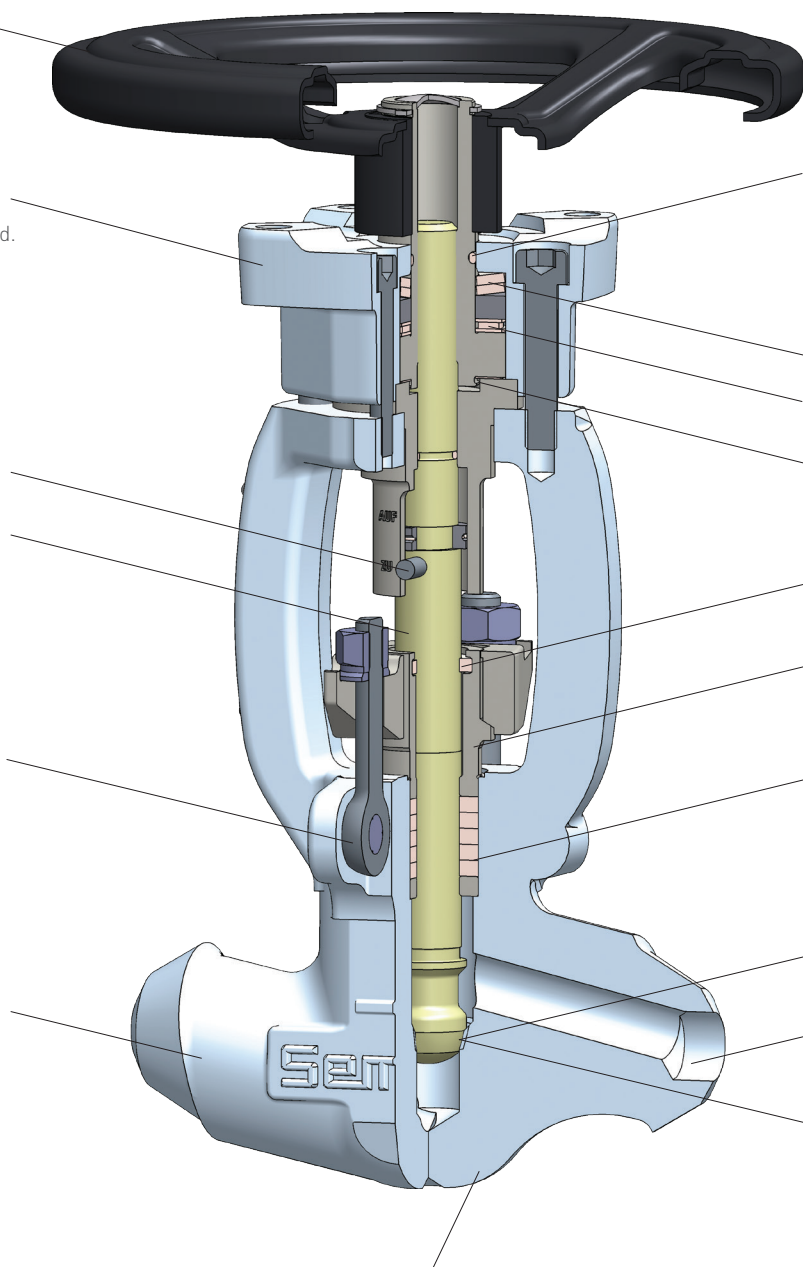

Capsuled valve yoke for protection against environmental influences.

Cup springs allowing the compensation of thermal stem extension to keep valve closed even at variations in temperature.

Low friction roller bearings for small driving forces. Capsuled valve yoke for protection against environmental influences.

Stripper-ring sealing of packing protects the stem/packing area against dirt and avoids leakage.

Two-piece gland for quick disassembly and repacking.

Pure graphite packing with non-extrusion ring prevents packing migration and ensures long service life.

Conical disc with line contact sealing for a defined seating for a tight shut off.

Sufficiency long cylindrical connections for heat treatment and UT- testing.

Wear resistant stellite seat ring welded and repairable. A special tool kit for lapping the seat is available.

Low pressure loss due to optimized flow path and large channel borings.

# SEPELL HIGH PRESSURE STOP VALVES

## MODEL VA500 (ASME)

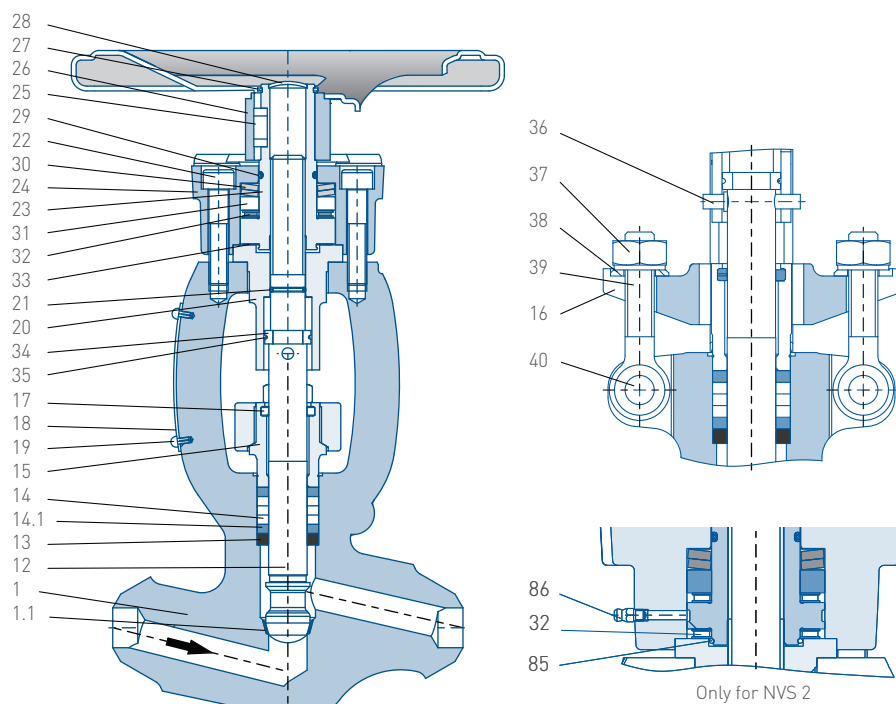

### PARTS KIT

Order ready-to-use and easy to select kit, with several parts under one single reference. Each set contains the necessary parts for one valve including parts listed below.

### PART LIST

Part	Description	Material specification				
		51	60	63	80	81 <sup>[1]</sup>
1	Body	(S)A105	(S)A182F12	(S)A182F22	(S)A182F91	(S)A182F347
1.1	Body seat			Stellite		
1.2	Welding neck flange	(S)A105	(S)A182F12	(S)A182F22	(S)A182F91	(S)A182F347
1.3	Welding neck flange	(S)A105	(S)A182F12	(S)A182F22	(S)A182F91	(S)A182F347
12	Stem			17% Cr		
13	Base ring			13% Cr		
14*	Packing			Graphite		
14.1*	Packing			Graphite-Austenite		
15	Gland shaft			13 % Cr		
16	Gland flange			13 % Cr		
17*	Wiper ring			Graphite		
18	Nameplate			Austenite		
19	Grooved pin			Austenite		
20	Guide bush			13% Cr		
21*	O-ring			FKM		
22	Allen bolt			Steel		
23	Threaded bush			Brass		
24	Cover			Steel		
25	Parallel key			Steel		
26	Handwheel			Steel		
27	Retaining ring			Spring steel		
28	Washer			Steel		
29	O-ring			FKM		
30	Disc spring			Spring steel		
31	Disc ring			13% Cr		
32	Axial needle bearing			Steel		
33	Slide ring			PTFE		
34	Split ring			17% Cr		
35	Ring			Austenite		
36	Guide bolt			17% Cr		
37	Hexagonal nut			Steel		
38	Washer			Steel		
39	Eye bolt			Steel		
40	Slotted pin			Austenite		
85**	Snap ring			Steel		
86**	Lubrication nipple			Steel		

### PARTS KIT TABLE

Sealing Set				
NVS	1/2	1	2	
Ref	50200096	50200099	50200100	
Parts	14, 14-1, 17, 21, 29			
Drive Set - Basic				
NVS	1/2	1	2*	
Ref	50232850	50232851	50232852	
Parts	12, 13, 23, 25, 27, 28, 29, 32, 33			
Drive Set - Plus				
NVS	1/2	1	2*	
Ref	50232854	50232855	50232856	
Parts	12, 13, 20, 23, 25, 27, 28, 29, 32, 33, 34, 35, 36			
Yoke Set				
NVS	1/2	1	2*	
Ref	50232857	50232858	50232859	
Parts	23, 25, 27, 28, 29, 32, 33			

\* Part 33 not included in NVS 2, replaced by two part 32 axial bearings.

### NOTES

- \* Commissioning parts
- \*\* Only for NVS 2
- 1. NVS 1/2 only on request

Screws and nuts corrosion protected.

# SEMPELL HIGH PRESSURE STOP VALVES

## MODEL VA500 (ASME)

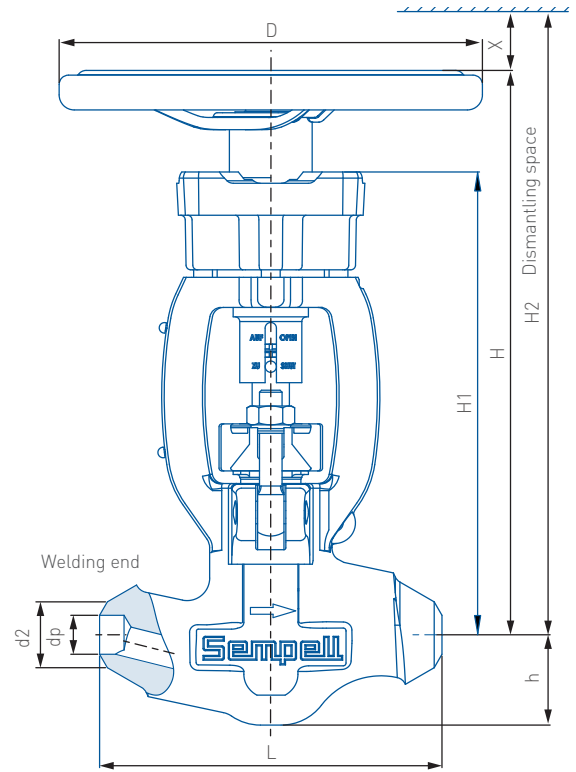
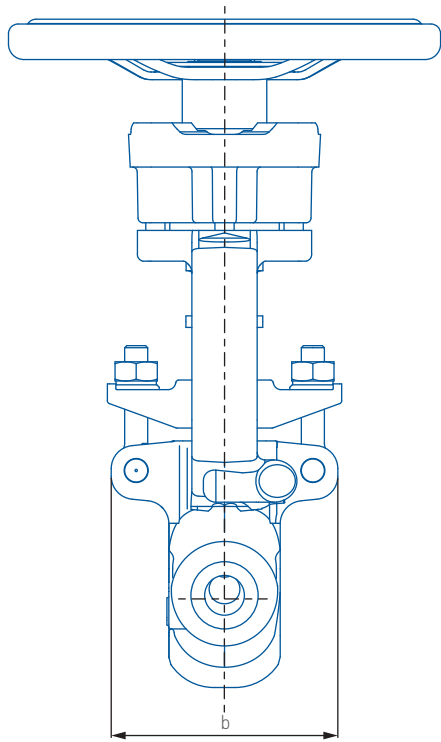

Socket weld end

Plain

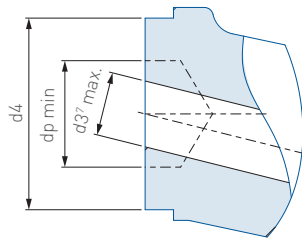
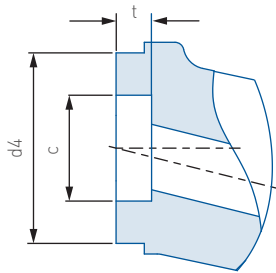

### DIMENSIONS

NPS	NVS	c	t	d4	
3/8	1/2	mm	17.600	10.00	40.50
		in	0.690	0.38	1.59
1/2	1/2	mm	21.800	13.00	40.50
		in	0.855	0.50	1.59
3/4	1	mm	27.100	13.00	56.50
		in	1.065	0.50	2.22
1	1	mm	33.900	13.00	56.50
		in	1.330	0.50	2.22
1 1/4	2	mm	42.700	13.00	97.00
		in	1.675	0.50	3.81
1 1/2	2	mm	48.800	13.00	97.00
		in	1.915	0.50	3.81
2	2	mm	61.200	16.00	97.00
		in	2.406	0.63	3.81

### DIMENSIONS

NVS	d3 <sup>[2]</sup> max	dp min	d4	
1/2	mm	13.00	18.00	40.50
	in	0.51	0.71	1.59
1	mm	20.00	26.00	56.50
	in	0.79	1.02	2.22
2	mm	40.00	50.00	97.00
	in	1.57	1.97	3.82

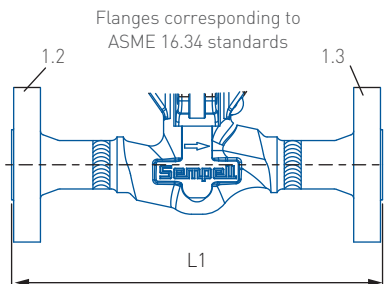

### DIMENSIONS

NVS	1/2	1	2	
3/8	CL.900-2680			
1/2	CL.900-2680			
3/4	CL.2680	CL.900-1680		
1	CL.2680	CL.900-1680		
1 1/4		CL.2680	CL.900-1680	
1 1/2		CL.2680	CL.900-1680	
2			CL.900-2680	
2 1/2			CL.900-2680	
NPS <sup>[1,4]</sup>	3 only standard class		CL.900-2680	
d2 (max.)	mm	38	54	94
	in	1.49	2.1	3.7
dp (min.)	mm	6	18	27
	in	0.24	0.7	1.06
L <sup>[2]</sup>	mm	160	180	300
	in	6.3	7.0	11.8
L1 <sup>[2]</sup>	mm	300	360	530
	in	11.8	14.1	20.8
b	mm	120	130	170
	in	4.7	5.1	6.7
H	mm	ca. 250	ca. 300	ca. 455
	in	ca. 9.8	ca. 11.8	ca. 17.9
H1 <sup>[3]</sup>	mm	195	245	385
	in	7.7	9.6	15.1
H2 <sup>[4]</sup>	mm	ca. 750	ca. 850	ca. 1205
	in	29.5	33.5	47.4
h	mm	35	45	75
	in	1.4	1.8	3
D	mm	200	225	350
	in	7.9	8.8	13.9
X	mm	ca. 500	ca. 550	ca. 750
	in	19.7	21.6	29.5
U/Stroke		5	7.5	10
Weight <sup>[5]</sup>	kg	8	12	40
	lbs	18	26	88

- Possible pipe connections
- Other end-to-end dimension on request
- Base line E-actuator
- Required dimension for disassembly with handwheel for rework
- Weight of flanged valves on request weight for W/M/U
- Only butt weld
- Corresponding to customer's request

# SEPELL HIGH PRESSURE STOP VALVES

## MODEL VA500 (ASME)

### Application ranges

Limited class for welding end valves in sizes NPS 2½ and smaller

Standard class for flanged valves

Recommended temperatures acc. to ASME B16.34

### WORKING PRESSURE BY CLASS (bar) – ASME B16.34

Class Temp °C	A105						A182F12						A182F22					
	900	1690	2680	900	1690	2680	900	1690	2680	900	1690	2680	900	1690	2680	900	1690	2680
	Standard			Limited			Standard			Limited			Standard			Limited		
-29 - 38	153	288	456	155	291	462	155	291	462	155	291	462	155	291	462	155	291	462
50	150	282	448	155	291	462	155	290	460	155	290	460	155	291	462	155	291	462
100	140	263	416	155	291	461	151	284	451	152	285	452	155	290	460	155	291	461
150	135	254	403	153	288	456	145	271	430	149	280	444	151	283	448	153	287	455
200	131	247	391	152	285	452	139	261	43	149	280	444	146	274	435	151	283	449
250	126	236	375	152	285	451	135	252	400	149	279	443	139	261	414	150	282	446
300	120	224	356	152	285	451	129	242	383	147	276	438	129	242	383	149	280	115
325	116	218	346	150	282	448	124	233	369	146	274	434	124	233	369	149	279	113
350	113	212	336	147	276	437	121	227	359	144	269	427	121	227	359	148	277	440
375	109	205	325	141	265	421	117	219	346	141	265	420	117	219	346	146	275	436
400	104	196	310	130	244	388	110	206	327	141	265	420	110	206	327	146	275	436
425	86	162	257	108	203	321	105	197	313	141	265	420	105	197	313	146	275	436
450	69	130	206	86	162	257	101	190	302	129	242	384	101	190	302	141	266	421
475	52	98	156	65	123	195	84	157	249	105	196	311	95	178	283	128	241	382
500	35	66	105	45	85	137	64	120	191	81	154	249	85	159	252	109	206	332
538	18	33	53	23	45	75	41	77	123	54	105	174	55	104	165	72	141	234
550	-	-	-	-	-	-	36	68	108	47	92	153	47	88	140	61	119	199
575	-	-	-	-	-	-	26	50	79	34	67	112	32	59	94	41	80	134
600	-	-	-	-	-	-	18	34	54	24	46	77	21	39	62	27	53	87
625	-	-	-	-	-	-	-	-	-	-	-	-	-	-	-	-	-	-

### WORKING PRESSURE BY CLASS (bar) – ASME B16.34

Class Temp °C	A182F91						A182F347					
	900	1690	2680	900	1690	2680	900	1690	2680	900	1690	2680
	Standard			Limited			Standard			Limited		
-29 - 38	155	291	462	155	291	462	149	280	443	155	291	462
50	155	291	462	155	291	462	146	275	436	155	291	462
100	155	290	460	155	291	462	136	255	405	152	285	452
150	151	283	448	155	291	462	127	239	379	142	267	423
200	146	274	435	155	291	462	120	225	357	134	251	398
250	139	261	414	155	291	462	113	213	358	127	238	377
300	129	242	383	155	291	462	108	203	322	121	227	360
325	124	233	369	155	291	462	106	199	316	118	222	352
350	121	227	359	154	290	459	104	196	310	116	219	347
375	117	219	346	152	284	451	103	193	306	115	215	341
400	110	206	327	151	283	448	102	191	303	114	213	338
425	105	197	313	149	280	443	101	189	300	113	211	335
450	101	190	302	141	266	421	100	188	299	112	210	333
475	95	178	283	128	241	382	95	178	283	112	210	333
500	85	159	252	109	206	332	85	159	252	107	201	319
538	75	141	224	90	177	295	75	141	224	87	163	259
550	75	141	223	90	177	295	-	-	-	-	-	-
575	72	135	214	89	174	291	-	-	-	-	-	-
600	59	110	174	76	149	248	-	-	-	-	-	-
625	44	82	130	57	111	186	-	-	-	-	-	-

### NOTES

Admissible working pressure (plain welding ends)

Test pressure = 1.5 × admissible working pressure at 38°C

# SEPELL HIGH PRESSURE STOP VALVES

## MODEL VA500 (ASME)

### Application ranges

Limited class for welding end valves in sizes NPS 2½ and smaller

Standard class for flanged valves

Recommended temperatures acc. to ASME B16.34

### WORKING PRESSURE BY CLASS (psig) – ASME B16.34

Class Temp °F	A105						A182F12						A182F22					
	Standard			Limited			Standard			Limited			Standard			Limited		
-20 - 100	2220	4180	6620	2250	4230	6700	2250	4230	6700	2250	4230	6700	2250	4230	6700	2250	4230	6700
200	2035	3830	6070	2250	4230	6700	2210	4150	6580	2210	4150	6580	2250	4230	6700	2250	4230	6700
300	1965	3690	5850	2220	4170	6620	2100	3940	6250	2165	4070	6450	2185	4110	6510	2220	4170	6610
400	1900	3580	5670	2200	4130	6550	2005	3770	5980	2165	4070	6450	2115	3980	6310	2185	4110	6510
500	1810	3400	5390	2200	4130	6550	1940	3640	5780	2155	4060	6430	1995	3750	5940	2175	4080	6470
600	1705	3200	5080	2200	4130	6550	1815	3410	5410	2125	3990	6330	1815	3410	5410	2165	4070	6450
650	1650	3100	4910	2145	4030	6390	1765	3320	5260	2090	3930	6230	1765	3320	5260	2145	4040	6400
700	1590	3010	4750	2075	3900	6180	1705	3200	5080	2050	3850	6100	1705	3200	5080	2120	3990	6320
750	1520	2860	4540	1905	3580	5670	1595	3000	4750	2050	3850	6100	1595	3000	4750	2120	3990	6320
800	1235	2320	3680	1545	2900	4600	1525	2870	4540	2050	3850	6100	1525	2870	4540	2120	3990	6320
850	955	1800	2850	1195	2250	3560	1460	2750	4360	1840	3460	5480	1460	2750	4360	2030	3820	6060
900	690	1300	2060	860	1620	2570	1120	2110	3340	1400	2640	4180	1350	2530	4020	1800	3380	5360
950	410	780	1230	565	1080	1745	825	1550	2450	1070	2050	3320	1160	2180	3460	1435	2740	4445
1000	255	490	770	335	655	1090	595	1130	1780	775	1515	2525	800	1510	2400	1045	2040	3400
1050	-	-	-	-	-	-	430	820	1290	570	1120	1860	525	990	1560	710	1390	2315
1100	-	-	-	-	-	-	290	550	860	385	755	1255	330	620	990	450	875	1455
1150	-	-	-	-	-	-	-	-	-	-	-	-	-	-	-	-	-	-

### WORKING PRESSURE BY CLASS (psig) – ASME B16.34

Class Temp °F	A182F91						A182F347					
	Standard			Limited			Standard			Limited		
-20 - 100	2250	4230	6700	2250	4230	6700	2160	4060	6440	2250	4230	6700
200	2250	4230	6700	2250	4230	6700	1985	3730	5920	2250	4170	6610
300	2185	4110	6510	2250	4230	6700	1850	3480	5520	2065	3880	6150
400	2115	3980	6310	2250	4230	6700	1730	3250	5150	1930	3630	5750
500	1995	3750	5940	2250	4230	6700	1625	3060	4850	1815	3410	5410
600	1815	3410	5410	2250	4230	6700	1550	2910	4610	1730	3250	5150
650	1765	3320	5260	2250	4230	6700	1520	2860	4530	1695	3190	5050
700	1705	3200	5080	2200	4130	6550	1490	2800	4400	1665	3130	4960
750	1595	3000	4750	2185	4110	6510	1475	2780	4400	1645	3100	4910
800	1525	2870	4540	2160	4060	6440	1460	2750	4360	1630	3070	4860
850	1460	2750	4360	2030	3820	6060	1455	2740	4340	1625	3050	4840
900	1350	2530	4020	1800	3380	5360	1350	2530	4020	1625	3050	4840
950	1160	2180	3460	1505	2880	4675	1160	2180	3460	1415	2660	4220
1000	1090	2060	3250	1310	2565	4275	1090	2060	3250	1260	2380	3760
1050	1080	2030	3220	1300	2545	4240	-	-	-	-	-	-
1100	905	1710	2700	1155	2260	3770	-	-	-	-	-	-
1150	670	1260	1900	870	1700	2835	-	-	-	-	-	-

### NOTES

Admissible working pressure (plain welding ends)

Test pressure = 1.5 × admissible working pressure at 100°F

# SEPELL HIGH PRESSURE STOP VALVES

MODEL VA500 (ASME)

## ACCESSORIES

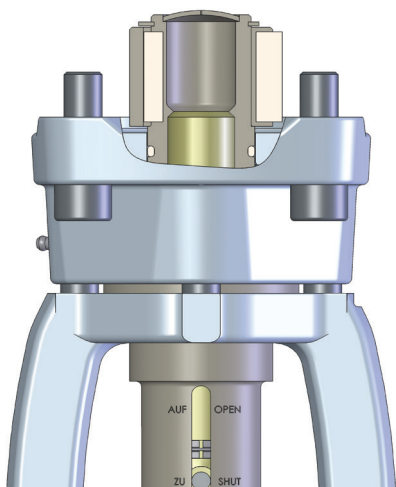

**SN33** Valve yoke with connection for an electrical actuator acc. to ISO 5210

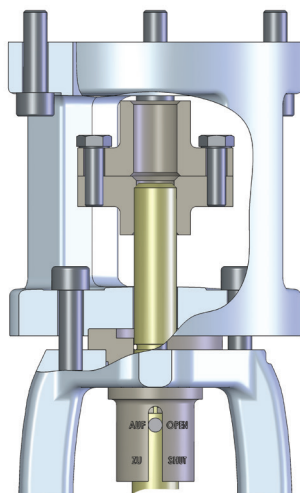

**SN34** Valve yoke with connection for a linear actuator acc. to DIN 3358  
(other connections available on request)

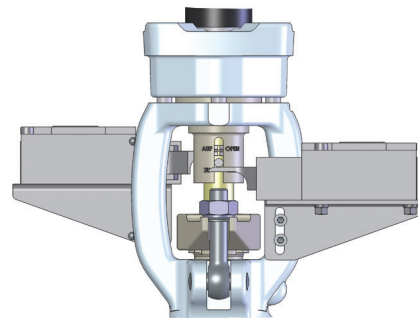

**SN36/37** Electrical limit switches "Closed/Open"

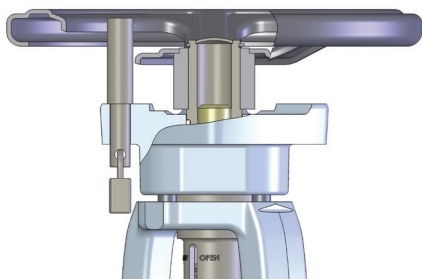

**SN38.1** Handwheel locking with pad lock

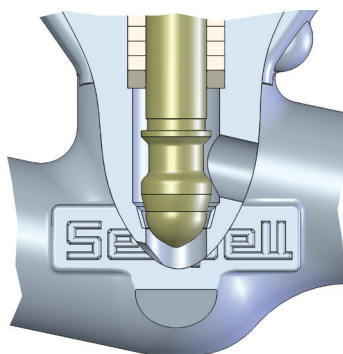

**SN45.1** Throttling disc (inlet below the disc only)

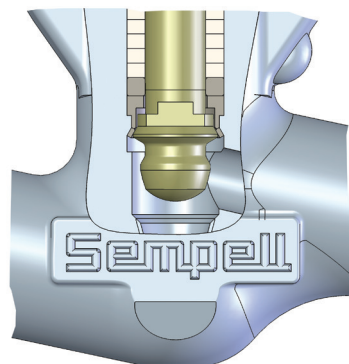

**SN53** Back seat arrangement

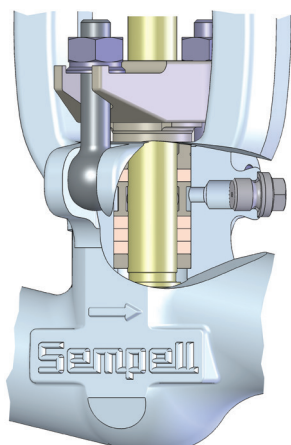

**SN30** Sealing water gland (lantern ring) for vacuum service

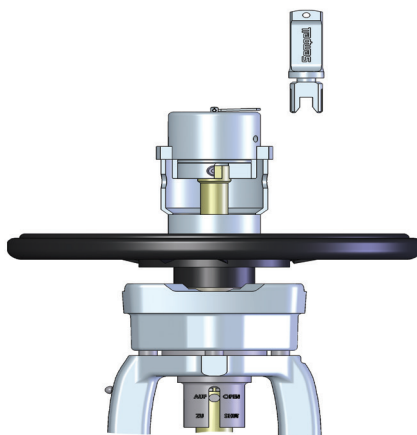

**SN371/2/3** Preparation for a Sempell valve lock. Different interlocking positions can be provided. The unique valve lock allows the layout of a locking system with certain operation sequences.

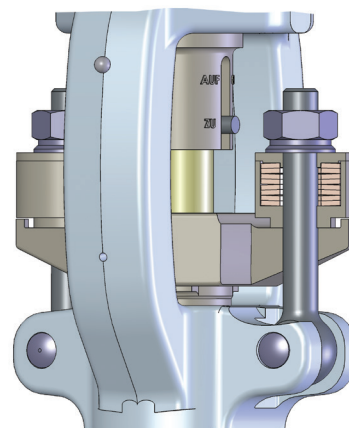

**SN160** Spring loaded gland for extended maintenance periods

# SEPELL HIGH PRESSURE STOP VALVES

## MODEL VA500 (ASME)

### SELECTION GUIDE

Example:	VA500	51	2680	1"	1"	G	W	25
<b>Valve type</b>								
<b>VA500</b>	Stop valve							
<b>Material specification</b>								
<b>51</b>	A105							
<b>60</b>	A182F12							
<b>63</b>	A182F22							
<b>80</b>	A182F91							
<b>81</b>	A182F347							
<b>Pressure rating weld end</b>								
<b>900</b>	Class 900							
<b>1690</b>	Class 1690							
<b>2680</b>	Class 2680							
<b>Pressure rating flange</b>								
<b>600</b>	Class 600							
<b>900</b>	Class 900							
<b>1500</b>	Class 1500							
<b>2500</b>	Class 2500							
<b>Nominal pipe size (NPS)</b>								
<b>3/8"</b>	NPS 3/8	<b>1 1/4"</b>	NPS 1 1/4					
<b>1/2"</b>	NPS 1/2	<b>1 1/2"</b>	NPS 1 1/2					
<b>3/4"</b>	NPS 3/4	<b>2"</b>	NPS 2					
<b>1"</b>	NPS 1	<b>2 1/2"</b>	NPS 2 1/2					
<b>Nominal valve size (NVS)</b>								
<b>1/2"</b>	NVS 1/2							
<b>1"</b>	NVS 1							
<b>2"</b>	NVS 2							
<b>Body design</b>								
<b>G</b>	Globe type (T-pattern)							
<b>Pipe connection</b>								
<b>W</b>	Welding ends acc. to ASME							
<b>M</b>	Socket weld end acc. to ASME							
<b>A</b>	Flange acc. to ASME							
<b>U</b>	Plain ends							
<b>SN</b>	<b>Designation</b>					<b>SN</b>	<b>Designation</b>	
25	Copper free materials					45.1	Throttling disc, inlet below disc	
30	Sealing water gland (lantern ring)					53	Back seat	
33A/B	Valve yoke with connection acc. to ISO 5210 size F10/F14					160.1	Spring-loaded gland	
34A-C	Connection for linear actuator acc. to DIN 3358					177	Nameplate operating pressure in MPa	
34F	Connection for linear actuator special design					178	Nameplate, foreign language	
36/37	Electrical limit switches for position indicator					182	Lubrication of stem thread	
38.1	Handwheel with pad lock					183	Inlet above disc	
41	Stellited disc seat					371	Valve lock A4-A5, locking position OPEN	
41.5	Stem and threaded bush nitrided					372	Valve lock A4-A5, Locking position CLOSED	
43.0	Welding rings inlet and outlet side					373	Valve lock A3, locking position OPEN or CLOSED	
43.2	Welding ring inlet side							
43.3	Welding ring outlet side							

VCTDS-02197-EN © 2009, 2023 Emerson Electric Co. All rights reserved 02/23. Sempell is a mark owned by one of the companies in the Emerson Automation Solutions business unit of Emerson Electric Co. The Emerson logo is a trademark and service mark of Emerson Electric Co. All other marks are the property of their prospective owners.

The contents of this publication are presented for informational purposes only, and while every effort has been made to ensure their accuracy, they are not to be construed as warranties or guarantees, express or implied, regarding the products or services described herein or their use or applicability. All sales are governed by our terms and conditions, which are available upon request. We reserve the right to modify or improve the designs or specifications of such products at any time without notice.

Emerson Electric Co. does not assume responsibility for the selection, use or maintenance of any product. Responsibility for proper selection, use and maintenance of any Emerson Electric Co. product remains solely with the purchaser.

Emerson.com