



HANCOCK 600 GATE, GLOBE AND CHECK VALVES

FORGED STEEL

A range of ASME class 800 and 1500 reduced bore forged steel valves with screwed, socket weld, butt weld or flanged ends



GENERAL APPLICATIONS

Designed for ASME Boiler and Pressure Vessel Code, Section I applications including vents, drains, by-pass systems, instrument isolation, control valve isolation, auxiliary steam lines, heat exchangers and oil and gas applications wherever reliable, leak-tight performance, under high temperature/pressure conditions, is required.

TECHNICAL DATA

Sizes: DN 15 - 50 (NPS ½ - 2)
 Pressure ratings: ASME Class 800 and 1500
 Body materials: Carbon steel and stainless steel

Connection standards:

- Screwed (NPT) to ASME B1.20.1
- Socket weld to ASME B16.11
- Flanged to ASME B16.5 classes 150, 300, 600, 1500
- Butt-welded ASME B16.25; JB/T12224
- Tested to: API 598

GATE VALVES

- A compact but extremely sturdy design for high pressure-temperature service.
- Available in bolted bonnet and welded bonnet, outside screw and yoke (OS and Y) construction.
- Conventional port design, with screwed, socket weld, butt weld or flanged ends.
- Direct metal-to-metal seating make the gate valve ideal for most shut-off applications.
- One piece, die-forged body.
- A precision machined, integral backseat is standard.
- Complies with API 602 and ASME B16.34.

GLOBE VALVES

- Available in bolted bonnet and welded bonnet outside screw and yoke (OS and Y) construction.
- Conventional port design, with flanged, screwed, socket weld or butt weld ends.
- All internal surfaces are accurately machined to provide maximum performance.
- One-piece, die forged body.
- A precision machined, integral backseat is standard.
- Complies with API 602 and ASME B16.34.

CHECK VALVES

- Piston style check valves for horizontal and vertical pipeline applications.
- The disc is hardened, ground and lapped.
- The integral seat hardfacing is overlaid directly onto the body base material, eliminating any possibility of leakage behind the seat (trim 8).
- Complies with API 602 and ASME B16.34.

HANCOCK 600 GATE VALVES

FORGED STEEL

GATE VALVE STANDARD FEATURES

Hancock gate valves are designed and manufactured to provide maximum service life and dependability. All gate valves meet the requirements of API 602 and ASME B16.34.

Gland/gland flange - rugged, forged steel, gland flange and separate gland are self aligning for straight line thrust against packing. No special tools required for packing adjustment.

Large spoked handwheel - for ease of operation and locking.

Integral bonnet and yoke - one piece forging is made from ASME Boiler and Pressure Vessel Code Section I listed materials.

High strength bonnet bolting - extra heavy hex head bolts use standard tools for easy maintenance.

Body-bonnet joint - metal-to-metal surface contact for automatic gasket compression control and elimination of joint overstressing.

Heavy duty yoke - takes high actuation loads.

Forged body and bonnet - in full accordance with ASME Boiler Pressure Vessel Code, Section I design and material requirements.

Standard hex gland nuts - can be adjusted with standard tools.

Fixed back seat - for positive, leakproof, packing chamber isolation. Fully machined for accurate seating.

Swing bolts hardened pins - for ease of repacking Pins are retained on both ends for maximum strength and safety.

Rugged stem - Wedge connection - one piece stem and tee slot design.

Graphite packing rings - with built in corrosion inhibitor for leak tight sealing at high and low pressures and temperatures.

Renewable hard faced seats - Stellite or equal, are standard with trim 5 and 8 Hancock gate valves.

Hardened wedge - precision guided in the body, eliminates seat surface contact until the fully closed position is reached, preventing early seat failure Wedge lifts completely clear of the flow passage for maximum flow.

Graphite filled stainless gasket - with controlled compression for maximum corrosion resistance and zero leakage.

Accurately machined guides - over the full stroke, keep wedge from twisting, binding or galling, prevents seat wear and prolongs service life.

Large ports and seats - for high flow and low pressure drop. Wedge lifts completely clear of the flow passage for maximum seat surface protection (full bore is optional).

End connections - in accordance with ASME B16.11, B16.25, B16.34 and B16.5 are available in threaded and socket weld configurations (flanged and butt weld are optional).

Full code compliance - all Hancock forged gate valves comply with API 602 and ASME B16.34.

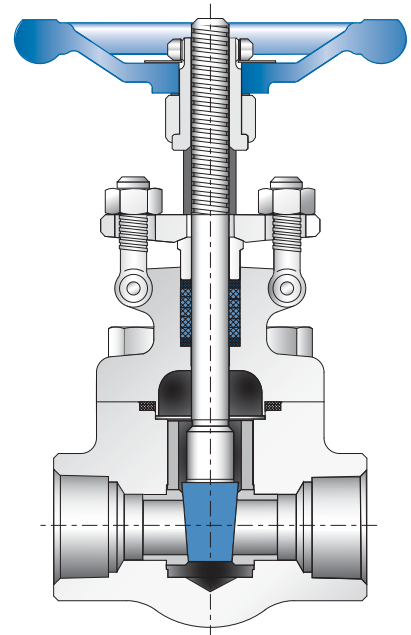

HANCOCK 600 GATE VALVES

FORGED STEEL

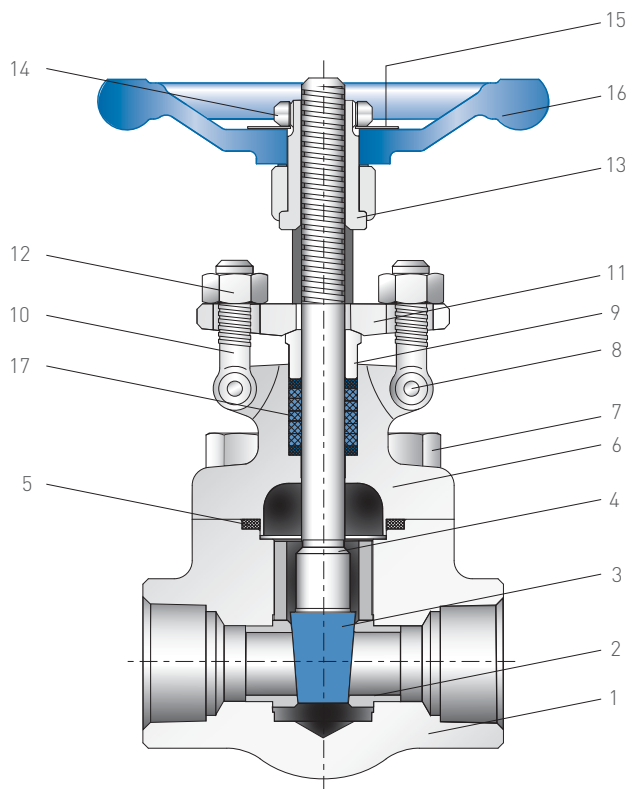

PARTS LIST

No.	Description	Material				
		A105/Trim 1	A105/Trim 5	A105/Trim 8	F304(L)/304(L)	F316(L)/316(L)
1	Body	A105	A105	A105	F304(L)	F316(L)
2	Seat	410	410+STL	410+STL	304(L)	316(L)
3	Wedge	420	420 + STL	420	F304(L)	F316(L)
4	Stem	410	410	410	304(L)	316(L)
5	Gasket	304 + Graphite	304 + Graphite	304 + Graphite	304 + Graphite	316 + Graphite
6	Bonnet	A105	A105	A105	F304(L)	F316(L)
7	Bolt	B7	B7	B7	B8	B8(M)
8	Pin	A29 1045	A29 1045	A29 1045	SS	SS
9	Gland	410	410	410	304	316
10	Gland eyebolt	B7	B7	B7	B8	B8(M)
11	Gland flange	A105	A105	A105	F304	F316
12	Hex nut	2H	2H	2H	8	8(M)
13	Stem nut	410	410	410	410	410
14	Locking nut	A29 1045	A29 1045	A29 1045	SS	SS
15	Nameplate	AL	AL	AL	AL	AL
16	Handwheel	Iron	Iron	Iron	Iron	Iron
17	Packing	Graphite	Graphite	Graphite	Graphite	Graphite

HANCOCK 600 GATE VALVES

FORGED STEEL

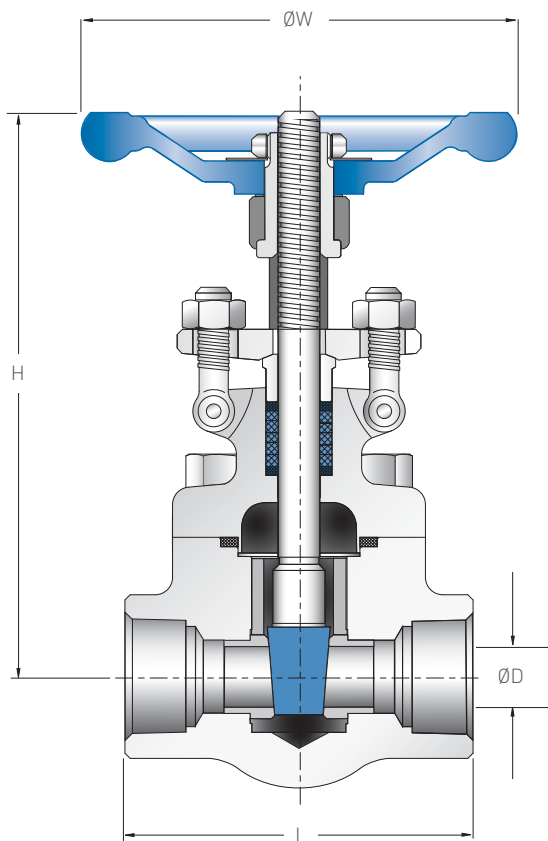

Dimensions for bolted and welded bonnet, reduced port OS and Y gate valves with screwed and socket weld ends.

ASME CLASS 800 DIMENSIONS mm (inches)

Valve size	$\varnothing D$	L	H	$\varnothing W$	Mass
DN NPS					kg (lbs)
15 1/2	10.5 (0.41)	79 (3.11)	140 (5.51)	100 (3.94)	2.2 (4.85)
20 3/4	13.5 (0.53)	92 (3.62)	143 (5.63)	100 (3.94)	2.2 (4.85)
25 1	18.0 (0.71)	111 (4.37)	170 (6.69)	125 (4.92)	4.7 (10.36)
32 1 1/4	23.0 (0.90)	120 (4.72)	197 (7.75)	160 (6.30)	5.9 (13.0)
40 1 1/2	29.0 (1.14)	120 (4.72)	210 (8.26)	160 (6.30)	6.9 (15.21)
50 2	36.0 (1.41)	140 (5.51)	245 (9.64)	185 (7.28)	11.1 (24.47)

ASME CLASS 1500 DIMENSIONS mm (inches)

Valve size	$\varnothing D$	L	H	$\varnothing W$	Mass
DN NPS					kg (lbs)
15 1/2	10.5 (0.41)	111 (4.37)	170 (6.69)	125 (4.92)	3.4 (7.49)
20 3/4	13.5 (0.53)	111 (4.37)	170 (6.69)	125 (4.92)	3.8 (8.37)
25 1	18.0 (0.71)	120 (4.72)	197 (7.75)	160 (6.30)	7.8 (17.19)
32 1 1/4	23.0 (0.90)	120 (4.72)	210 (8.26)	160 (6.30)	11.9 (26.23)
40 1 1/2	29.0 (1.14)	140 (5.51)	245 (9.64)	180 (7.08)	12.2 (26.89)
50 2	36.0 (1.41)	178 (7.00)	280 (11.02)	225 (8.85)	21.9 (48.28)

HANCOCK 600 GLOBE VALVES

FORGED STEEL

GLOBE VALVE STANDARD FEATURES

Hancock globe valves are designed and manufactured to provide maximum service life and dependability. All globe valves meet the requirements of API 602, ASME B16.34 and the ASME Boiler and Pressure Vessel Code, Section I.

Large spoked handwheel - for ease of operation and locking.

Heavy duty yoke - takes high actuation loads.

Standard hex gland nuts - can be adjusted with standard tools.

Acme stem thread - for maximum strength, smooth quick operation.

Swing bolts hardened pins - for ease of repacking pins are retained on both ends for maximum strength and safety.

Integral bonnet and yoke - one piece forging is made from ASME Boiler and Pressure Vessel Code Section I listed materials.

Graphite packing - rings with built in corrosion inhibitor for leak tight sealing at high and low pressures and temperatures.

Gland/gland flange - rugged, forged steel, gland flange and separate gland are self aligning for straight line thrust against packing. No special tools required for packing adjustment.

High strength bonnet bolting - extra heavy hex head bolts use standard tools for easy maintenance.

Graphite filled stainless gasket - with controlled compression for maximum corrosion resistance and zero leakage.

Forged body and bonnet - in full accordance with ASME Boiler Pressure Vessel Code, Section I design and material requirements.

Large ports and seats - for high flow and low pressure drop (full bore optional).

Body-bonnet joint - metal to metal surface contact for automatic gasket compression control and elimination of joint overstressing.

End connections - in accordance with ASME B16.11, B16.25, B16.34 and B16.5 are available in threaded and socket weld configurations.

Fixed back seat - for positive, leakproof, packing chamber isolation. Fully machined for accurate seating.

Rugged stem-wedge connection - one piece stem and tee slot design is the strongest in the industry.

Hardened disc - precision ground for accurate, positive seating.

Full code compliance - all Hancock forged globe valves comply with API 602 and ASME B16.34.

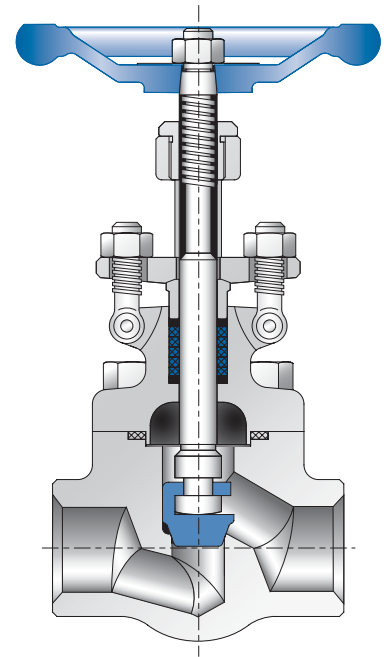

HANCOCK 600 GLOBE VALVES

FORGED STEEL

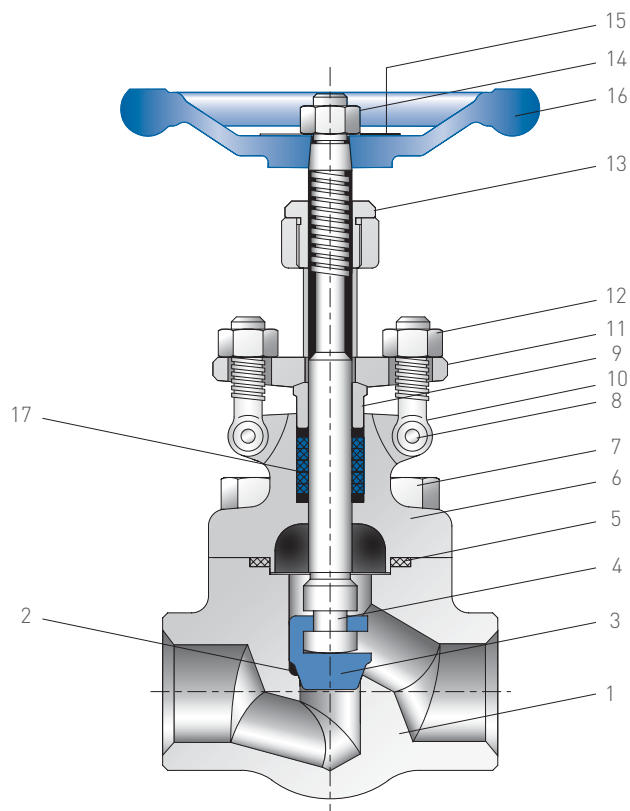

PARTS LIST

No.	Description	Material				
		A105/Trim 1	A105/Trim 5	A105/Trim 8	F304(L)/304(L)	F316(L)/316(L)
1	Body	A105	A105	A105	F304(L)	F316(L)
2	Seat	410	410+STL	410+STL	304(L)	316(L)
3	Disc	420	420 + STL	420	F304(L)	F316(L)
4	Stem	410	410	410	304(L)	316(L)
5	Gasket	304 + Graphite	304 + Graphite	304 + Graphite	304 + Graphite	316 + Graphite
6	Bonnet	A105	A105	A105	F304(L)	F316(L)
7	Bolt	B7	B7	B7	B8	B8(M)
8	Pin	A29 1045	A29 1045	A29 1045	SS	SS
9	Gland	410	410	410	304	316
10	Gland eyebolt	B7	B7	B7	B8	B8(M)
11	Gland flange	A105	A105	A105	F304	F316
12	Hex nut	2H	2H	2H	8	8(M)
13	Stem nut	410	410	410	410	410
14	Locking nut	Carbon steel	Carbon steel	Carbon steel	Stainless steel	Stainless steel
15	Nameplate	AL	AL	AL	AL	AL
16	Handwheel	Iron	Iron	Iron	Iron	Iron
17	Packing	Graphite	Graphite	Graphite	Graphite	Graphite

HANCOCK 600 GLOBE VALVES

FORGED STEEL

ASME CLASS 800 DIMENSIONS mm (inches)

Valve size		ØD	L	H	ØW	Mass
DN	NPS					kg (lbs)
15	½	9.5 (0.37)	79 (3.11)	150 (5.90)	100 (3.94)	1.7 (3.75)
20	¾	12.5 (0.49)	92 (3.62)	150 (5.90)	100 (3.94)	1.9 (4.19)
25	1	17.0 (0.67)	111 (4.37)	175 (6.88)	125 (4.92)	3.1 (6.83)
32	1¼	23.0 (0.90)	120 (4.72)	215 (8.46)	160 (6.30)	4.9 (10.80)
40	1½	28.0 (1.10)	152 (5.98)	230 (9.05)	160 (6.30)	6.3 (13.88)
50	2	36.0 (1.41)	172 (6.77)	260 (10.23)	185 (7.28)	9.7 (21.38)

ASME CLASS 1500 DIMENSIONS mm (inches)

Valve size		ØD	L	H	ØW	Mass
DN	NPS					kg (lbs)
15	½	9.0 (0.35)	111 (4.37)	175 (6.88)	125 (4.92)	3.3 (7.27)
20	¾	10.0 (0.39)	111 (4.37)	180 (7.08)	125 (4.92)	3.3 (7.28)
25	1	15.0 (0.59)	120 (4.72)	215 (8.46)	160 (6.30)	5.2 (11.46)
32	1¼	20.0 (0.78)	152 (5.98)	230 (9.05)	160 (6.30)	6.6 (14.55)
40	1½	25.0 (0.98)	172 (6.77)	260 (10.23)	185 (7.28)	10.2 (22.48)
50	2	27.0 (1.06)	220 (8.66)	305 (12.00)	225 (8.85)	13.2 (29.10)

Dimensions for bolted and welded bonnet, reduced port OS and Y globe valves with screwed and socket weld ends.

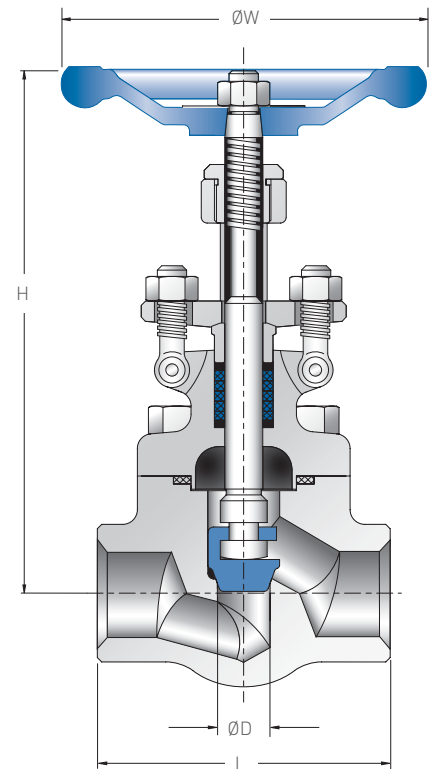

CHECK VALVE STANDARD FEATURES

Hancock check valves are designed and manufactured to provide maximum service life and dependability. All check valves meet the requirements of API 602 and ASME B16.34.

Body cover joint - metal-to-metal surface contact for automatic gasket compression and elimination of flange overstraining.

High strength bolting - extra heavy hex head bolts use standard tools for easy maintenance.

Forged body and cover - in full accordance with ASME Boiler and Pressure Vessel Code - Section 1 design and material requirements.

Top entry design - allows for complete valve maintenance without removal from the line.

Hardened disc - precision guided on cover centerpost. Flat seat design ensures positive alignment of seating surfaces, regardless of valve's installed position, and absorbs sudden closure impact.

Graphite filled gasket - spiral wound, stainless steel, graphite filled, with controlled compression for zero leakage at maximum design pressure and temperature.

Hard faced seat - all hardfacing is overlaid to extra depth, to ensure maximum repairability. Inconel® Spring (optional), allows for positive closure at full valve temperature rating.

Full code compliance - complies with ASME B16.34.

Center guided disc - keeps disc from misalignment and/or binding.

End connections - in accordance with ASME B16.11, B16.25, B16.34 and B16.5 are available in threaded and socket weld.

Built in relief port - allows rapid evacuation of line fluid from disc cavity.

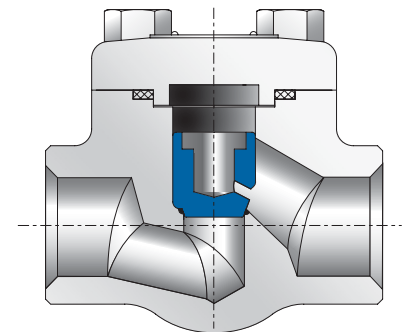

HANCOCK 600 CHECK VALVES

FORGED STEEL

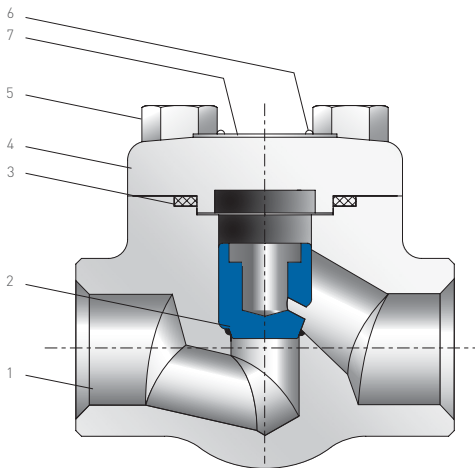

PARTS LIST

No.	Description	Material				
		A105/Trim 1	A105/Trim 5	A105/Trim 8	F304(L)/304(L)	F316(L)/316(L)
1	Body	A105	A105 + STL	A105 + STL	F304(L)	F316(L)
2	Disc	420	420 + STL	420	F304(L)	F316(L)
3	Gasket	304 + Graphite	304 + Graphite	304 + Graphite	304 + Graphite	316 + Graphite
4	Cover	A105	A105	A105	F304(L)	F316(L)
5	Bolt	B7	B7	B7	B8	B8(M)
6	Rivet	AL	AL	AL	AL	AL
7	Nameplate	Stainless steel	Stainless steel	Stainless steel	Stainless steel	Stainless steel

Integral seat is in body; stellite hard facing is optional (trim 8).

Dimensions for bolted and welded bonnet, reduced port piston style check valves with screwed or socket weld ends.

ASME CLASS 800 DIMENSIONS mm (inches)

Valve size		ØD	L	H	Mass
DN	NPS				
15	½	9.5 [0.37]	79 [3.11]	60 [2.36]	1.7 [3.85]
20	¾	12.5 [0.49]	92 [3.62]	60 [2.36]	1.9 [4.19]
25	1	17.0 [0.66]	111 [4.37]	75 [2.95]	3.1 [6.83]
32	1¼	23.0 [0.90]	120 [4.72]	80 [3.14]	4.9 [10.8]
40	1½	28.0 [1.10]	152 [5.98]	95 [3.74]	6.3 [13.88]
50	2	36.0 [1.41]	172 [6.77]	115 [4.52]	9.7 [21.38]

ASME CLASS 1500 DIMENSIONS mm (inches)

Valve size		ØD	L	H	Mass
DN	NPS				
15	½	9.0 [0.35]	111 [4.37]	75 [2.95]	3.3 [7.27]
20	¾	10.0 [0.39]	111 [4.37]	75 [2.95]	3.3 [7.27]
25	1	15.0 [0.59]	120 [4.72]	80 [3.14]	5.2 [11.46]
32	1¼	20.0 [0.79]	152 [5.98]	95 [3.74]	6.6 [14.55]
40	1½	25.0 [0.98]	172 [6.77]	115 [4.52]	10.2 [22.48]
50	2	27.0 [1.06]	220 [8.66]	125 [4.92]	13.2 [29.10]

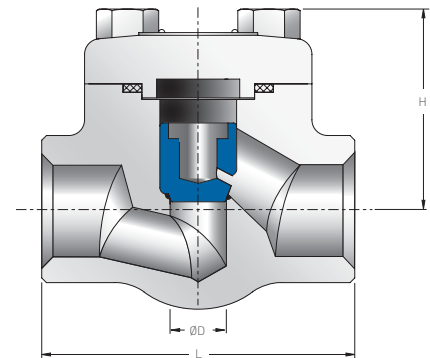

PHOBE-0054-EN © 2010, 2021 Emerson Electric Co. All rights reserved 11/21. Hancock is a mark owned by one of the companies in the Emerson Automation Solutions business unit of Emerson Electric Co. The Emerson logo is a trademark and service mark of Emerson Electric Co. All other marks are the property of their prospective owners.

The contents of this publication are presented for informational purposes only, and while every effort has been made to ensure their accuracy, they are not to be construed as warranties or guarantees, express or implied, regarding the products or services described herein or their use or applicability. All sales are governed by our terms and conditions, which are available upon request. We reserve the right to modify or improve the designs or specifications of such products at any time without notice.

Emerson Electric Co. does not assume responsibility for the selection, use or maintenance of any product. Responsibility for proper selection, use and maintenance of any Emerson Electric Co. product remains solely with the purchaser.

Emerson.com/FinalControl