

## Data Sheet

Sheet No.: DPI-C and DPI-E

Date: October 2010

DPI-C and DPI-E

# DPI-C and DPI-E position indicators for BHH/BHHF actuators

## Description:

The DPI is designed to fit Bettis quarterturn valve actuators BHH and BHHF for use within the temperature range from  $-20^{\circ}\text{C}$  to  $+80^{\circ}\text{C}$  ( $-4^{\circ}\text{F}$  to  $+176^{\circ}\text{F}$ ). The DPI range consists of the DPI-E (ON/OFF/switches), DPI-C (Continuous/potentiometer) and the hydraulic DPI-B (Bypass).

For further information about the DPI-B, please see separate data sheet.

## Basic design:

The DPI-C and -E can be mounted in different mounting blocks or in LPU, with only internal wiring.

Valve/actuator position is indicated by means of a precision potentiometer or 2 microswitches. Resistance (commonly used  $\Omega$  output) increases during opening and decreases during closing the valve/ actuator. Set point adjustment is performed without dismounting the DPI or cable from the LPU or block.

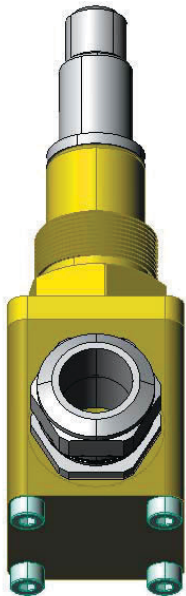

DPI mounted in LPU on BHH actuator.

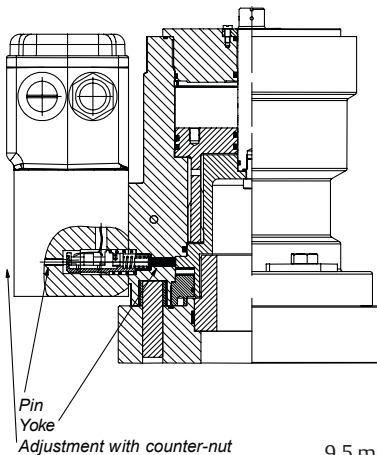

DPI mounted on BHH actuator.

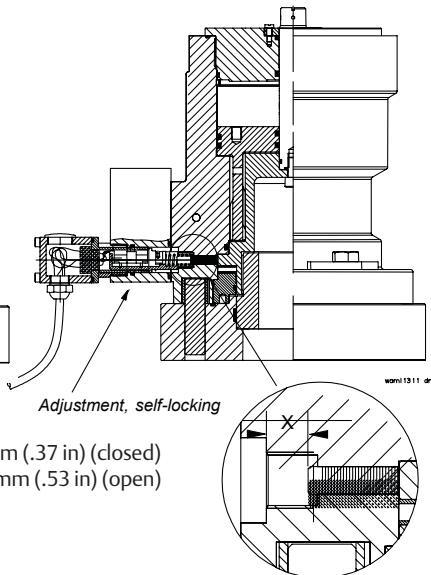

X= 9.5 mm (.37 in) (closed)  
13.5 mm (.53 in) (open)

## Mounting and adjustments:

When mounting the DPI-C/-E be sure not to press the DPI too far towards the actuator. Several misadjustments of the DPI may cause destruction of the DPI.

When the valve/actuator is closed you may adjust the DPI by screwing it towards the actuator until the...

- DPI-C: potentiometer reaches the desired  $300\ \Omega$  ( $1500\ \Omega$ ), or
- DPI-E: CLOSED switch closes (opens if NC configuration), and then adjust the desired overlap ( $1^{\circ}$  -  $5^{\circ}$ ).

Check the indicator signal in open position. When DPI is mounted in a block, make sure that the locking screw is tightened sufficiently to prevent the DPI from turning. When mounted in LPU remember to tighten the counter-nut. If correct adjustment is not possible - check the yoke distance "X" (see enlargement), and the presence of the yoke.

**BETTIS**

Copyright © Emerson. The information in this document is subject to change without notice. Updated data sheets can be obtained from our website [www.emerson.com/bettis](http://www.emerson.com/bettis) or from your Emerson Automation Solutions - Actuation Technologies Center:

America's: +1 281 477 4100 Europe: +36 22 53 0950 Asia/Pacific: +65 67 77 8211 Middle East: +971 4 811 810

  
**EMERSON**

## Data Sheet

Sheet No.: DPI-C and DPI-E

Date: October 2010

DPI-C and DPI-E

### Potentiometer:

Standard resistance values:  
Total resistance tolerance:  
Independent linearity tolerance:  
Resolution:  
Output smoothness:  
Insulation resistance:  
Dielectric strength:  
Resistance temperature coefficient:  
Operating temperature range:  
Temperature cycle:

**- Total resistance value variation:**  
- No mechanical damage

**Exposure at low temperature:**  
- Total resistance value variation  
- No mechanical damage

**Exposure at high temperature:**  
- Total resistance value variation  
- No mechanical and electrical damage

**Vibration:**  
- Total resistance value variation  
- No mechanical and electrical damage

**Shock:**  
- Total resistance value variation  
- No mechanical and electrical damage

**Moisture resistance:**  
- Total resistance value variation  
- Insulation resistance

**Life expectancy:**  
Total resistance value variation

### Switches:

Contact resistance:  
Switching current:  
Dielectric strength:  
Life expectancy: Min.  
Insulation resistance:  
Humidity:

1k  $\Omega$ , 2k  $\Omega$ , 10k  $\Omega$   
Precision class  $\pm$  20%  
Precision class  $\pm$  5%  
Essentially infinite  
Below 0.1% against input voltage  
Over 50 M  $\Omega$  at 500 V DC  
1 minute at 500 V AC  
 $\pm$  400 p.p.m./ $^{\circ}$ C  
-55 $^{\circ}$  C to +125 $^{\circ}$  C  
5 cycles under -55 $^{\circ}$  C to 125 $^{\circ}$  C  
(-67 $^{\circ}$  F to +257 $^{\circ}$  F)  
Below  $\pm$ 10%.

24 hours at -55 $^{\circ}$  C (-67 $^{\circ}$  F)  
Below  $\pm$  5%.

1,000 hours at 105 $^{\circ}$  C (+221 $^{\circ}$  F)  
Below  $\pm$  10%.

10 Hz to 2,000 Hz 20 G  
Below  $\pm$  2%.

50 G 7 mS  
Below  $\pm$  1%

40 $^{\circ}$  C (+104 $^{\circ}$  F) 95% RH 120 hours  
Below  $\pm$ 10%  
Over 10 M  $\Omega$

500,000 cycles  
Below  $\pm$  10% against initial value

Max. 100 m  $\Omega$   
Max. 100 mA at 30 V DC resistive load  
1500 V AC to ground 1 minute  
100,000 operations  
100 M  $\Omega$  at 500 V DC  
Max. 85%

**BETTIS**<sup>™</sup>

  
**EMERSON**<sup>™</sup>

Copyright © Emerson. The information in this document is subject to change without notice. Updated data sheets can be obtained from our website [www.emerson.com/bettis](http://www.emerson.com/bettis) or from your Emerson Automation Solutions - Actuation Technologies Center:

America's: +1 281 477 4100 Europe: +36 22 53 0950 Asia/Pacific: +65 67 77 8211 Middle East: +971 4 811 810

# Data Sheet

Sheet No.: DPI-C and DPI-E

Date: October 2010

# DPI-C and DPI-E

## Terminal layout:

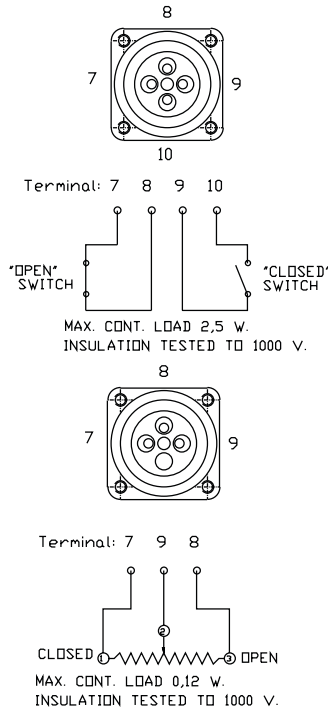

## Enclosure rating:

When mounted in block, cavity seals are designed to fulfill demands of enclosure rating IP 68. Note: In case of installation where a larger enclosure rating than IP 67 is required, the connection house should be filled with silicone after wire mounting and test of function. With each actuator comes a yoke, fit to transfer the mechanical signal from the actuator to the DPI.

## Potentiometer:

The potentiometer incorporated in the DPI-C is a high quality potentiometer that is extremely reliable as long as the following ratings are observed:

Max. continuous load:	0.12 W (VA)
Max. peak load:	1 W(VA)
The normal output range is at	1 kΩ: 0-500 Ω for 0-90° rotation*
	2 kΩ: 300-1400 Ω for 0-90° rotation*
	10 kΩ: 1500-7000 Ω for 0-90° rotation*

\* Approx. adjustment for open (1400/7000) and close (300/1500) set point.

## Analogue signal processing:

LPU is equipped with signal conditioning, with a 2-wire 4 - 20 mA signal output. When DPI-C is block mounted we recommend the Bettis isolation amplifier 2204 for transforming the resistance signal into a standard 4-20 mA signal.

The output can be displayed visually by means of the Bettis meter PQ 48 measuring 48 x 48 mm and scaled: "closed, 1/4, 1/2, 3/4, open".

## Materials:

Housing:	Brass, MS 58 (CuZn39Pb3)
Screws:	AISI 304 (Stainless)
Seals:	NBR ~ Acrylonitrile Butadiene
Fixture:	PPS

## Cable gland data:

Cable outer diameter:	ø 6-10.5 or ø 8-15 mm (.24-.39 or .31 - .59 in)
Ingress protection:	IP 68
Thread:	M 16 or M 20
Material:	Nickel plated brass
Seal material:	Perbunan and NBR (Rubber)

## Cable quality/connection:

Wiring to the terminal: Cross sections 0.5-1.5 mm<sup>2</sup> (AWG 22 - 16). Observe that water intrusion into the terminal housing can take place through the cable - even through each individual wire. The IP tightness is based on correct and careful mounting.

Note: Not Certified dimensional drawings. Such drawings are available on request. Contact factory with correct model designation and serial number. Important: Due to Emerson's continuing commitment to engineered product advancement, data presented herein is subject to change.

The contents of the publication are presented for information purposes only, and while effort has been made to ensure their accuracy, they are not to be construed as warranties or guarantees, express or implied, regarding the products or services described herein or their use or applicability. All sales are governed by our terms and conditions, which are available on request. We reserve the right to modify or improve the designs or specifications of our products at any time without notice.

# BETTIS™

Copyright © Emerson. The information in this document is subject to change without notice. Updated data sheets can be obtained from our website [www.emerson.com/bettis](http://www.emerson.com/bettis) or from your Emerson Automation Solutions - Actuation Technologies Center.  
America's: +1 281 477 4100 Europe: +36 22 53 0950 Asia/Pacific: +65 67 77 8211 Middle East: +971 4 811 810