



## KEYSTONE F410 COMPOSITE HANDLE

A new generation manual operator grip made of a high tech composite material suitable for many butterfly valves with Keystone topplate



### FEATURES

- Solid sturdy design.
- Ergonomic grip ensures efficient and easy operation, even with elevated or low temperature fluids, the handle remains comfortable and eliminates the need for dew point barriers.
- Corrosion resistant material  
The new handle is made from a composite material; a mixture of a polymer matrix, reinforced with glass fibers. The material itself is resistant to outdoor environments.
- High strength material and design  
Do not confuse this material with ordinary plastics. Composite is a light weight and high strength material. To optimize the material properties in combination with the unique production methods, the handle has been designed with a mosaic of reinforcement bridges which are visible from the bottom side.
- Innovative mounting design by using a bayonet connection between the handle and throttling plate. When the handle is mounted to the valve the bayonet connection is secured by the mounting bolts.
- Raised above insulation piping.
- Can be locked in 10 positions.
- Integrated position indication.
- Clear indication of disc position.
- Provision for padlock device (recommended Shackle diameter 1/4").
- Axial blocked shaft with throttling plate (blow-out proof).

### GENERAL APPLICATION

The leverlock F410 handle is suitable for many valves which require manual operators. Typical examples are distribution units and risers in HVAC installations and other applications where pipes are insulated. Material degradation is possible in contact with strong acids, bases and oxidizing environments. Although relatively new in the valve industry, it is broadly used in the automotive industry for construction components.

### TECHNICAL DATA

Size range: For Keystone valves  
DN 25-150 (NPS 1-6)



# KEYSTONE F410 COMPOSITE HANDLE

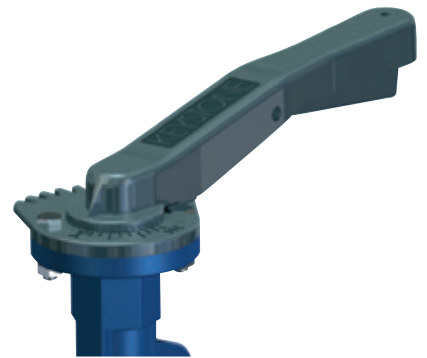
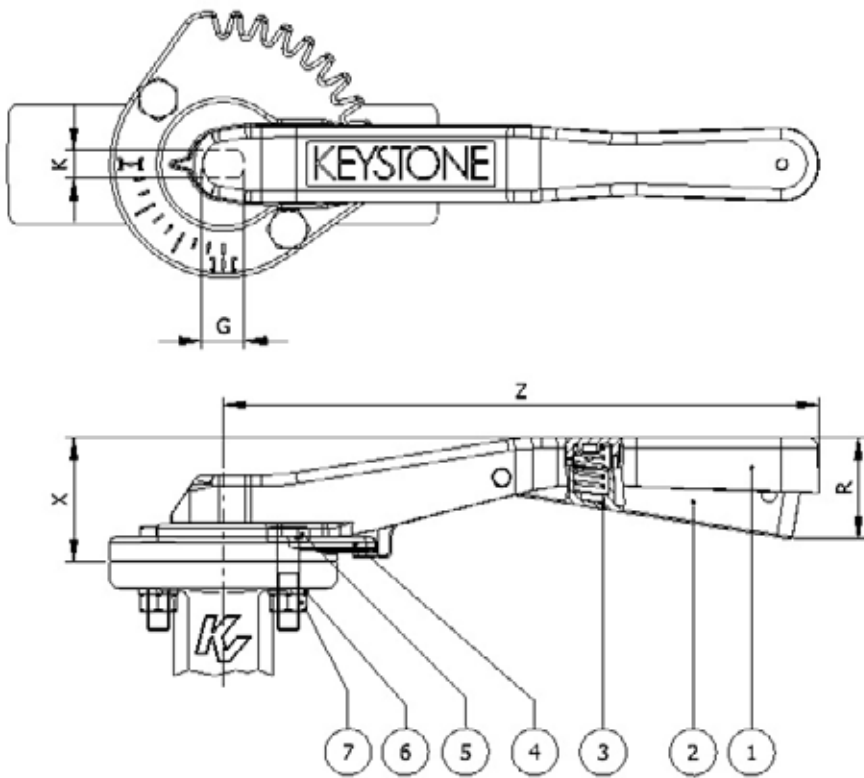

## HANDLE DIMENSIONS (in mm)

Handle	Valve size		G	K	R	X	Z	Mass gr (lb) composite
	DN (NPS)							
410	25 - 40 (1 - 1.5)		9.53 (0.38)	6.35 (0.25)	37 (1.46)	42 (1.65)	180 (7.09)	100 (0.22)
410	50 - 80 (2-3)		14.28 (0.56)	9.50 (0.37)	50 (1.97)	56 (2.20)	267 (10.51)	320 (0.70)
410	100 (4)		15.88 (0.63)	11.10 (0.44)	50 (1.97)	56 (2.20)	267 (10.51)	320 (0.70)
410	125 - 150 (5 - 6)		19.05 (0.75)	12.70 (0.50)	50 (1.97)	56 (2.20)	267 (10.51)	320 (0.70)

## PARTS LIST

Part	Name
1	Handle bar
2	Handle lever
3	Spring
4	Throttling plate
5	Screw
6	Spring washer
7	Nut

## MAXIMUM OPERATING TORQUE AND FORCE

Handle	Valve size DN (NPS)	Maximum operating force in N (in kg) / lb	Torque generated at max. force in Nm (lb)
410	25 - 40 (1-1.5)	250 (25) / 0.55	35 (310)
410	50 - 80 (2-3)	820 (82) / 1.80	175 (1549)
410	100 (4)	820 (82) / 1.80	175 (1549)
410	125 - 150 (5 - 6)	820 (82) / 1.80	175 (1549)

## MATERIAL SPECIFICATION F410

Part name	Material	EN designation	EN material number	Remarks
Handle bar	Composite			
Handle lever	Composite			
Spring	Stainless steel	X 5 CrNiMo 17 12 2	1.4401	
Throttling plate	Composite			
Screw	Stainless steel	X 5 CrNiMo 17 12 2	1.4401	
Spring washer	Stainless steel	X 5 CrNiMo 17 12 2	1.4401	
Nut	Stainless steel	X 5 CrNiMo 17 12 2	1.4401	

## MATERIAL SELECTION F410

Handle bar	Handle lever	Throttling plate	Mounting material	Trim number	Sizes DN (NPS)
Composite	Composite	Composite	Stainless steel	542	25 - 150 (1 - 6)



Neither Emerson, Emerson Automation Solutions, nor any of their affiliated entities assumes responsibility for the selection, use or maintenance of any product. Responsibility for proper selection, use, and maintenance of any product remains solely with the purchaser and end user.

Keystone is a mark owned by one of the companies in the Emerson Automation Solutions business unit of Emerson Electric Co. Emerson Automation Solutions, Emerson and the Emerson logo are trademarks and service marks of Emerson Electric Co. All other marks are the property of their respective owners.

The contents of this publication are presented for informational purposes only, and while every effort has been made to ensure their accuracy, they are not to be construed as warranties or guarantees, express or implied, regarding the products or services described herein or their use or applicability. All sales are governed by our terms and conditions, which are available upon request. We reserve the right to modify or improve the designs or specifications of such products at any time without notice.

[Emerson.com/FinalControl](http://Emerson.com/FinalControl)